

OWNERS OPERATING MANUAL

and PARTS LIST

MODEL 2290-1

20 INCH
ROTARY MOWER



0611-576

PRINTED IN U.S.A.

YARD-MAN INC

Jackson Michigan

BUILDERS OF THE ORIGINAL SILENT YARD-MAN LAWN MOWER

RULES FOR SAFE OPERATION

Your rotary mower is a precision piece of power equipment. Engineering skill and experience have been combined to provide the ultimate in safety and efficiency, however, as with any type of power equipment, carelessness or error on the part of the operator can result in injury. Exercise extreme caution at all times.

1. **KNOW YOUR MACHINE** Read the Owner's Manual carefully - learn how to operate your mower properly.
2. **MAKE SURE THE LAWN IS CLEAR** of sticks, stones, wire and other hazardous items from lawn before mowing. Such items are dangerous to both the mower and individuals in the vicinity of the mower.
3. **ADD FUEL** before starting engine - - - never when engine is hot or running.
4. **ALWAYS STOP ENGINE** and disconnect sparkplug wire before attempting any repairs or adjustments.
5. **START ENGINE CAREFULLY** Always stand at side opposite discharge chute. **NEVER PLACE HANDS OR FEET UNDER THE MOWER OR NEAR THE DISCHARGE CHUTE WHILE THE ENGINE IS RUNNING.**
6. **DO NOT TILT MOWER** at extreme angle while engine is running. Cut grass on hills and banks sideways.
7. **STOP THE ENGINE** when not cutting grass.
8. **DO NOT ALLOW MINORS** to operate mower unless thoroughly instructed and properly supervised.
9. **KEEP CHILDREN AND PETS AWAY** from area at all times during mowing operation.
10. **DISENGAGE ALL BLADE AND DRIVE CLUTCHES** before starting units so equipped. Do not attempt to start engine while mower is resting in high grass.

LAWN CARE

1. It is not advisable to cut off more than 1/3 of the total length of the grass at any one mowing.
2. When mowing thick, lush wet grass, start at outside of lawn and mow in counter-clockwise direction to prevent mower from recutting clippings from previous rounds.
3. When mowing thin or dry grass, start at outside of lawn and mow in clockwise direction to progressively discharge clippings to center of lawn where they can easily be removed.
4. Recommended normal cutting heights for different types of grass:

| | |
|------------------------------|---------------------|
| 1½ to 2½ — Med. to Med. High | Marion blue grass |
| 1½ to 2½ — Med. to Med. High | Kentucky blue grass |
| 1 to 2 -- Med. - Low to Med. | Fescues |
| 1 to 2 — Med. - Low to Med. | Rye grass |
| 1 to 1½ — Low to Med. Low. | Bermuda |
| 1 to 1½ — Low to Med. Low. | Zoysia |
| 1 to 2 — Med. - Low to Med. | Bent grass |

SUGGESTIONS FOR MORE EFFICIENT, AND MAINTENANCE-FREE OPERATION

GENERAL MOWING:

1. Always keep mower blade "Knife" sharp and balanced for maximum cutting efficiency.
2. Always start engine with mower on level surface where blade will not drag on tall grass or other obstructions. After starting, let engine warm up several minutes at slow speed before starting to mow.
3. When mowing under normal conditions, run mower at $\frac{1}{2}$ to $\frac{3}{4}$ throttle for best results.
4. When cutting tall heavy growth, or on rough ground, place mower in highest cut position and gradually reduce to desired cutting height over course of two or three mowings.

USING GRASS CATCHER:

1. When using grass catcher, operate mower engine at $\frac{3}{4}$ to full throttle.
2. In heavy dense turf, set cutting height in medium to high position.
3. Allow wet grass to dry before attempting to mow with grass catcher attached.
4. Empty catcher bag thoroughly before storage.

MAINTENANCE

Your mower like all machines with moving parts must receive care and maintenance. The following tips, if used, will contribute many trouble-free hours to your mower.

1. Check oil level frequently. When changing oil, make sure dirt and debris cleaned off oil sump before removing oil plug.
2. Keep mower clean, especially the engine well and underside of mower housing.
3. Check all nuts, bolts and screws occasionally to be sure mower is in good operating condition.
4. Should excessive vibration develop, check your blade and crankshaft immediately. Do not operate mower with an unbalanced blade, a damaged blade or a damaged crankshaft.
5. The wheel bearings are pre-lubricated at the factory and should require no further attention until mower is serviced. However, it is advisable to remove the wheels and apply a small amount of light oil to each axle, at least once a season.
6. If you are going to store your mower for any length of time (30 days or longer) it is important that the following steps be taken:
 - a. Drain the gas tank and carburetor. Allow the engine to run out of gas, gasoline left in the engine will leave gum deposits in the carburetor and gas tank.
 - b. Clean engine of all foreign matter.
 - c. Lubricate cylinder by removing the spark plug and pouring one ounce of clean lubricating oil through the spark plug hole into the cylinder, Crank engine slowly to spread oil and replace spark plug.
7. Just as your automobile needs professional mechanical maintenance from time to time, so does your air cooled engine. A yearly tune-up and check by a qualified service center is recommended to avoid breakdowns and unnecessary delays during the cutting season.

PREPARING YOUR YARD-MAN MOWER FOR USE

SET UP

Your mower is shipped in one carton completely assembled with the handle assembly in the shipping or storage position. To remove your mower from the carton, slit the end of the carton and roll the mower out. **DO NOT** attempt to lift the unit by the engine shroud.

To place the handle in operating position, lift the handle assembly until the lower section snaps into the operating position as shown. The upper section can now be fitted into place. Fasten the upper and lower sections together with the handle mounting knobs.

NOTE: Make sure the handle knobs are loose enough to allow the upper section to pivot freely around the mounting bolts when placing the handle in either operating or storage position.



GRASS CATCHER

To assemble—place rear support rod into tubes provided on the front frame assembly. Then insert frame assembly into the bag through the zipper opening. Make sure the elastic in the mouth of the bag sets properly in the groove in the frame assembly. Attach to the mower by placing it over the discharge chute with the pins on the underside of the catcher opening locating into the holes in the mower discharge chute.

BEFORE STARTING ENGINE

Remove oil fill plug and fill the crankcase with S.A.E. No. 30 oil. (1¼ pints approx.)

Fill fuel tank completely full with a good grade regular clean, fresh gasoline. **DO NOT MIX OIL WITH GASOLINE.** FOR COMPLETE ENGINE INFORMATION, READ ENGINE INSTRUCTION BOOKLET BEFORE STARTING ENGINE.

TO START ENGINE

1. Place throttle control knob in FAST or RUN position.
2. While standing at the left side of the mower, opposite the discharge chute, pull the starter rope with a quick full stroke. Repeat if necessary.
3. When engine starts, move throttle control knob to slow speed until engine warms up.

NOTE: If engine floods, place throttle control knob in "Stop Position." Pull starter rope at least 4 times. This will clear the engine of excess gas. Then reposition control lever to "Run" position and follow the normal starting procedure.

Engine flooding is usually caused by a dirty air cleaner. Service air cleaner regularly as noted in engine instruction manual.

If engine continues to flood even with a clean air filter, lean carburetor adjustment screw 1/8 turn. (See engine instructions)

TO ADJUST HEIGHT OF CUT

The cutting height of your mower can easily be adjusted from low to high cut. Place your hand on the outside of the wheel, spring the adjusting lever, with your thumb, outward until the locating trunnion on the lever is free from the housing. Move the wheel and lever to the height of cut desired. Release the lever, allowing the trunnion to drop into the proper locating hole.

CAUTION: Do not make adjustments with the engine running.

TO CHANGE OIL

Engine oil should be changed after the first 5 hours of operation and each 25 hours of operation thereafter.

Drain oil while engine is warm. Disconnect spark plug wire and secure at least 1" away from spark plug. Block right hand side of mower up about 4" high and set shallow one quart container beneath oil drain. Remove oil drain plug from sump and allow oil to drain completely. Replace plug and refill with S.A.E. #30 oil. (1 1/4 pints approx.)

BREAK-IN PERIOD

During the first ten hours of operation, check the following items frequently:

- Oil Level
- All nuts, bolts and screws for tightness
- Condition of Blade

TO REPLACE BLADE

1. Be sure engine is stopped, disconnect spark plug wire and secure at least 1" away from spark plug.
2. Tip mower on the side and remove the blade and adaptor from engine crank.
3. Remove the blade from the adaptor and replace with a new blade. Reassemble to engine.
4. Resharpenering of an old blade should only be attempted by a Wards Service Center. This way proper blade balance will be maintained.

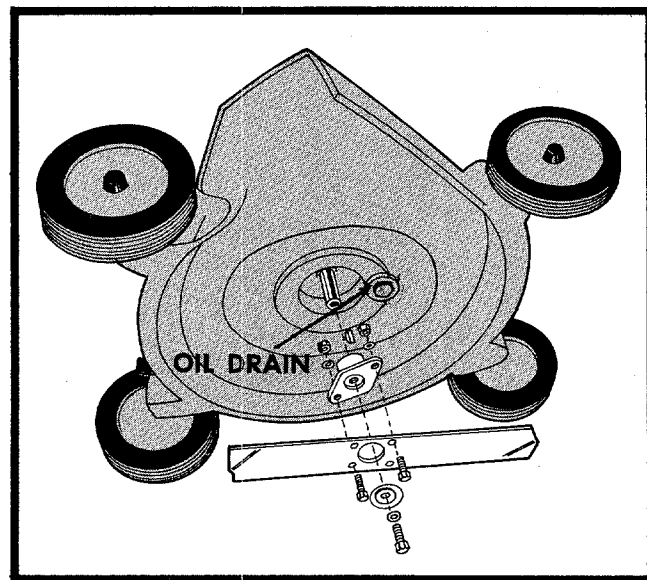
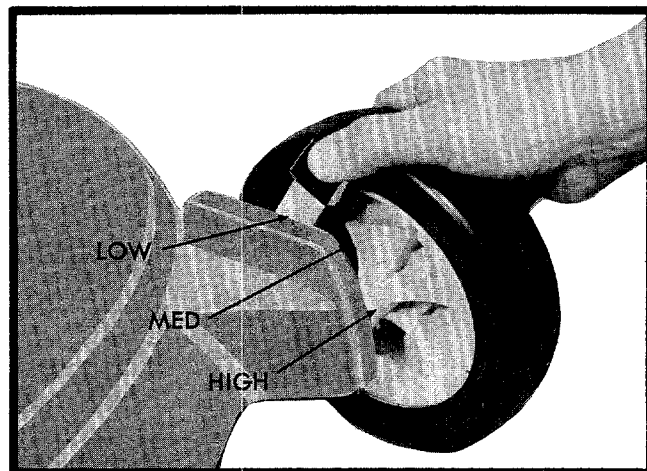

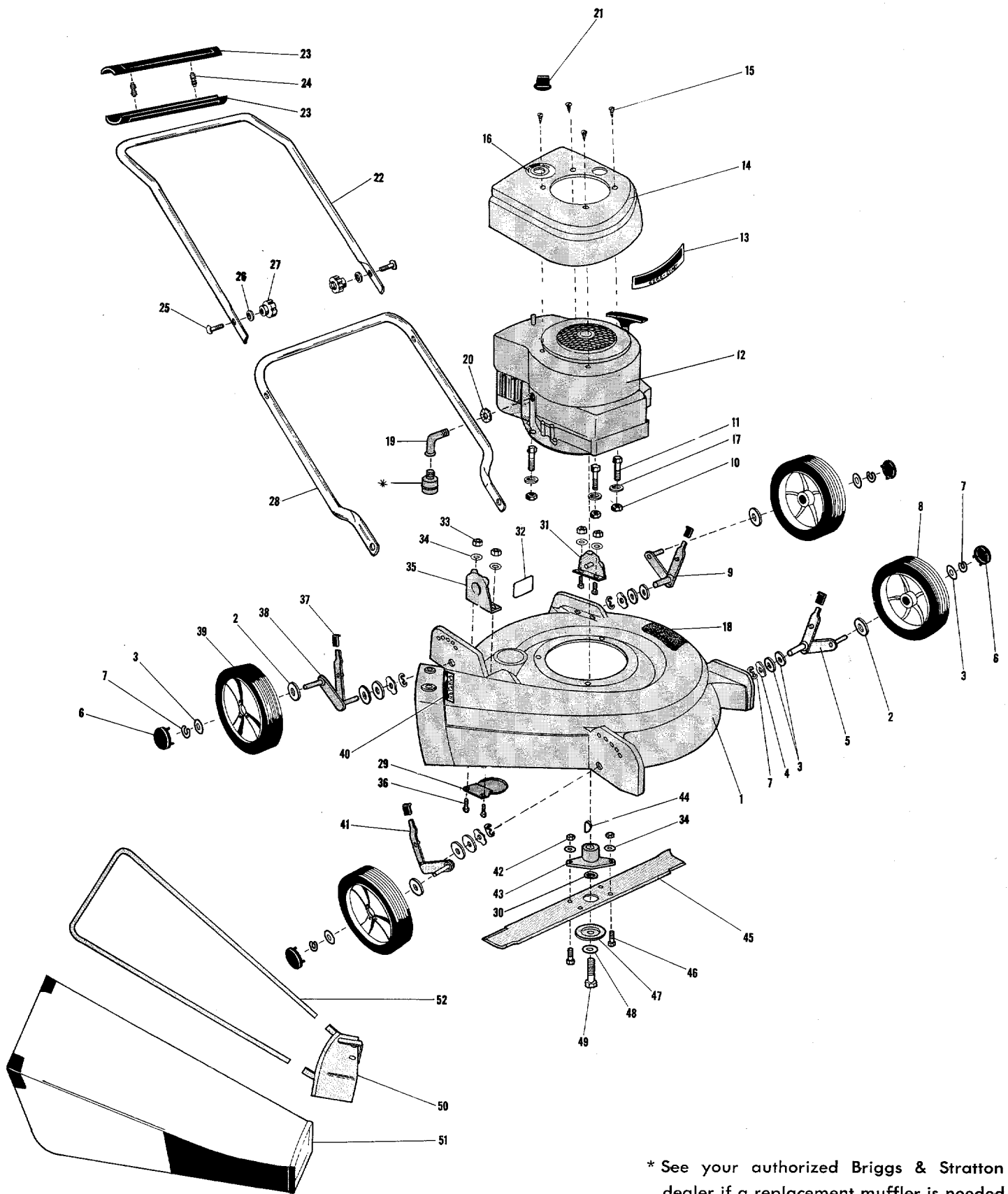

* See your authorized Briggs & Stratton dealer if a replacement muffler is needed

PARTS LIST

MODEL 2290-1

Your Mower is right hand (R.H.) or left hand (L.H.) as you Mow.

| REF. NO. | PART NO. | NAME OF PART | REF. NO. | PART NO. | NAME OF PART |
|-------------|-------------|--|-------------|-------------|---|
| 1 | 6601-123-17 | Blade Housing | 27 | 1643-47 | Knob—Hand |
| 2 | 1540-86 | Washer (½ x 1.0 x ⅛) | 28 | 3712-83-01 | Handle—Lower |
| 3 | 1540-90 | *Washer (½ x 1.00 x .030) | 29 | 2556-18 | Deflector—Muffler |
| 4 | 1552-2 | *Washer—Wave | 30 | 1624-135 | Washer (¾ x 1.0 x .210) |
| 5 | 2123-31-17 | Ass'y—Front Axle L.H. | 31 | 2132-87-17 | Ass'y—Bracket & Pin (L.H.) |
| 6 | 2674-39-40 | Hub Cap | 32 | 1605-456 | Name Plate |
| 7 | 1650-1 | Retaining Ring | 33 | 1538-19 | *Nut (¼-20 Hex Lock) |
| 8 | 2108-124-41 | Ass'y—Wheel & Tire (7 x 1.75) ... | 34 | 1018 | *Washer—Lock (¼ Split) |
| 9 | 2123-33-17 | Ass'y—Rear Axle (L.H.) | 35 | 2132-86-17 | Ass'y—Bracket & Pin (R.H.) |
| 10 | 1538-6 | *Nut—Lock (5/16-18 Hex) | 36 | 1529-15 | *Bolt (¼-20 x ⅝ Carriage) |
| 11 | 1509-75 | *Bolt (5/16-18 x 1½ Hex. Hd.) ... | 37 | 2643-43 | Knob—Adjust Lever |
| 12 | | Ass'y—Engine—B & S Model 92908 Type 0722-01 | 38 | 2123-32-17 | Ass'y—Rear Axle (R.H.) |
| 13 | 2616-295 | Label—Engine Shroud | 39 | 2108-125-41 | Ass'y—Wheel & Tire Rear (8 x 1.75) |
| 14 | 4699-67-17 | Shroud—Engine | 40 | 1616-299 | Label—Caution |
| 15 | 1526-1 | Screw—Shroud Retaining | 41 | 2123-30-17 | Ass'y—Front Axle (R.H.) |
| 16 | 1616-297 | Label—Dial Control | 42 | 1538-8 | *Nut (¼-20 Hex Hd. Lock) |
| 17 | 159 | Washer (5/16 x ⅝ x 1/16) | 43 | 1143-5-17 | Ass'y—Blade Adapter |
| 18 | 2662-21 | Pad—Foot | 44 | 1646-8 | Key (#6 Woodruff) |
| 19 | 1756-4-47 | Elbow—Exhaust | 45 | 3604-39-17 | Blade—Grass |
| 20 | 1539-67 | Nut—Elbow Retaining | 46 | 1509-34 | *Bolt (¼-20 x ¾ Hex. Hd.) |
| 21 | 2643-44 | Knob—Throttle Control | 47 | 1543-39 | Washer—Special |
| 22 | 3712-84-01 | Handle—Upper | 48 | 1542-8 | *Lockwasher (¾ Split) |
| 23 | 2710-40 | Grip—Handle | 49 | 1509-101 | *Bolt (¾-24 x 1½ Hex Hd. Lock) ... |
| 24 | 1547-35 | Pin—Special | 50 | 3168-38-17 | Ass'y—Frame |
| 25 | 1513-103 | Bolt (5/16-18 x 1¾ Curved Hd.) ... | 51 | 4670-12 | Bag—Grass Catcher |
| 26 | 1542-2 | Washer—Lock (5/16 Int. Sems) ... | 52 | 4753-5 | Rod—Rear Support |

For Illustration See Page 6.

*Standard Hardware Item, May Be Purchased Locally.

When you own this - - **YARD-MAN**

20" ROTARY MOWER

you enjoy these outstanding features

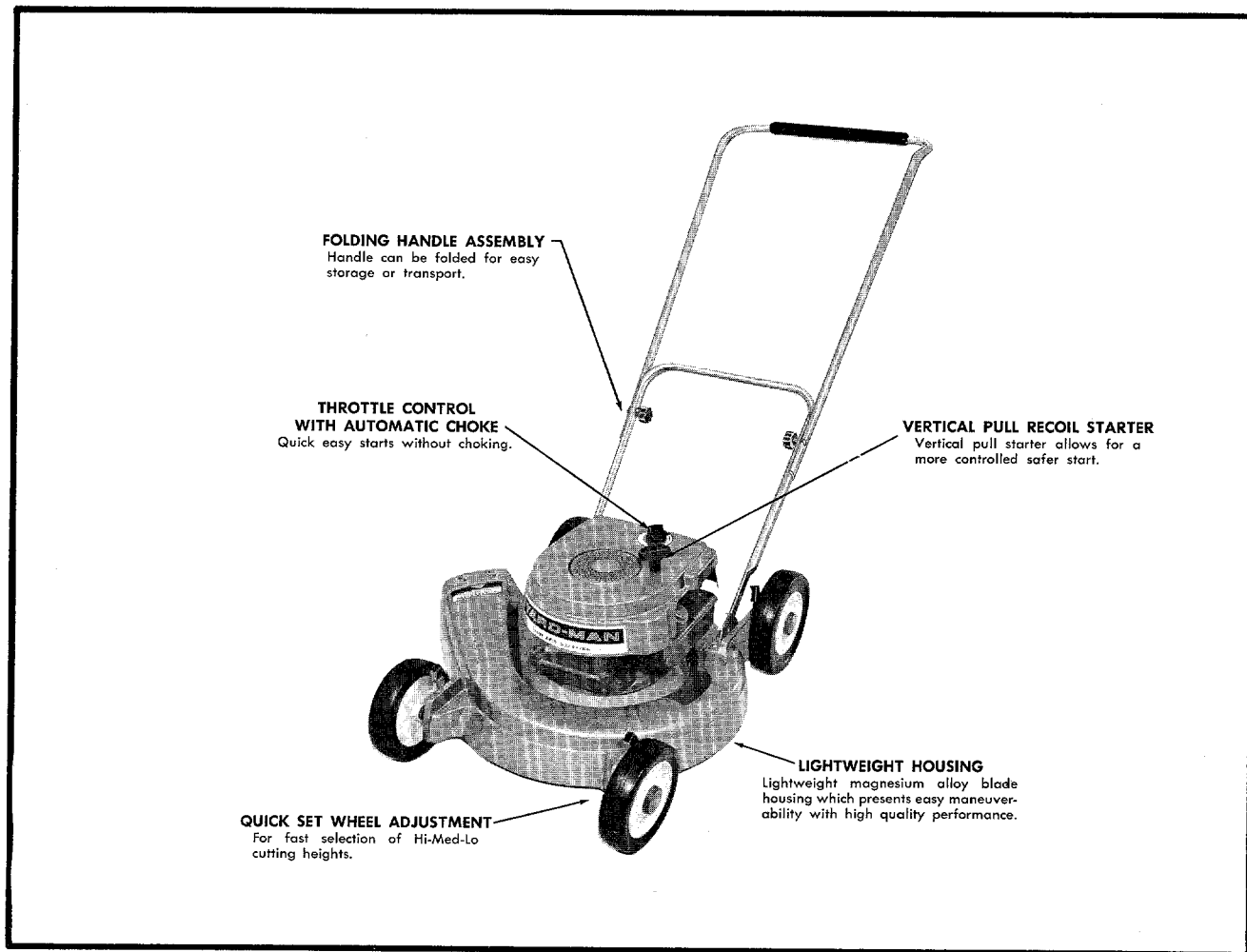

WARRANTY

This YARD-MAN unit is guaranteed for one year from date of purchase (90 days when used commercially) against defects in workmanship or material under normal use and service.

We agree to repair or replace without charge to the purchaser, including labor, any part proven to be defective within the warranty period, except the Engine which is the responsibility of the Engine manufacturer.

Parts for this YARD-MAN unit will be available for at least ten years from the date of purchase. This warranty will not apply to a unit which has been subjected to—misuse, negligence, an accident, or to a unit which has been altered in any way.

YARD-MAN INC

JACKSON, MICHIGAN