

OWNERS

OPERATING MANUAL

and PARTS LIST

MODEL 2320-2

20 INCH

ROTARY MOWER

ELECTRIC START

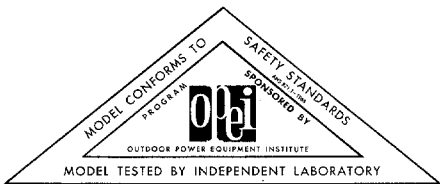
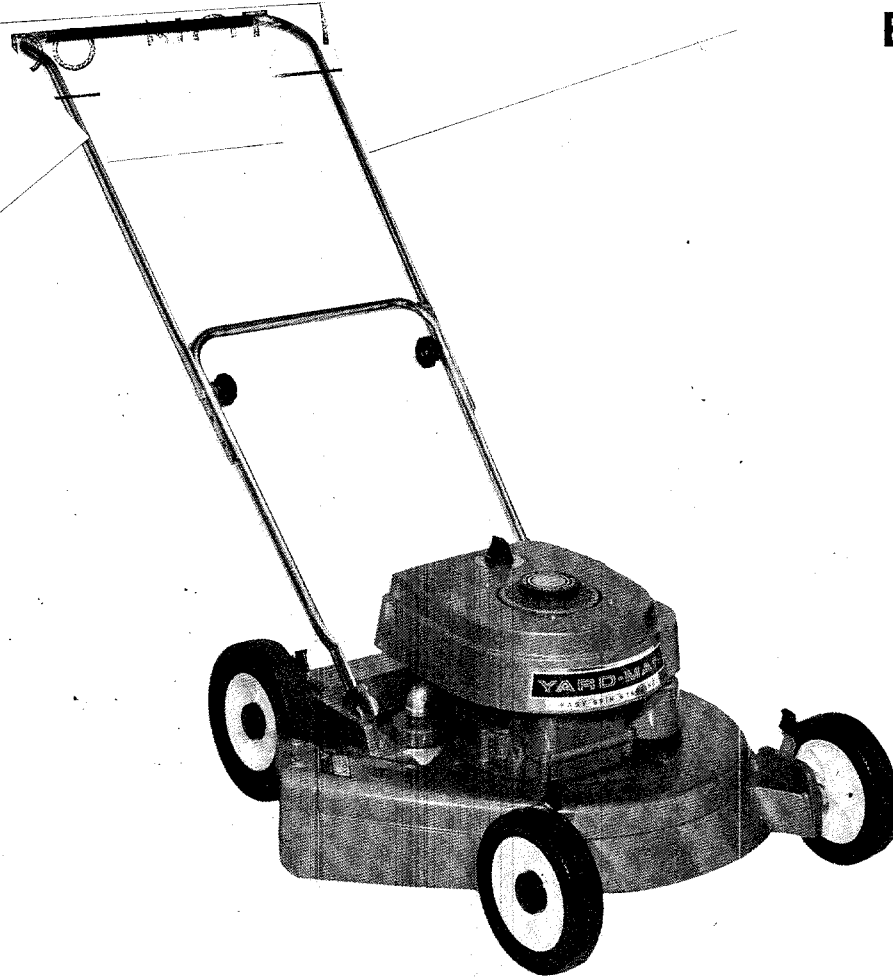

0611-659

PRINTED IN U.S.A.

YARD-MAN

J a c k s o n M i c h i g a n

RULES FOR SAFE OPERATION

Your rotary mower is a precision piece of power equipment. Engineering skill and experience have been combined to provide the ultimate in safety and efficiency, however, as with any type of power equipment, carelessness or error on the part of the operator can result in injury. Exercise extreme caution at all times.

1. **KNOW YOUR MACHINE** Read the Owner's Manual carefully - learn how to operate your mower properly.
2. **MAKE SURE THE LAWN IS CLEAR** of sticks, stones, wire and other hazardous items from lawn before mowing. Such items are dangerous to both the mower and individuals in the vicinity of the mower.
3. **ADD FUEL** before starting engine - - - never when engine is hot or running.
4. **ALWAYS STOP ENGINE** (turn off switch or disconnect sparkplug wire) before attempting any repairs or adjustments.
5. **START ENGINE CAREFULLY** Always stand at side opposite discharge chute. **NEVER PLACE HANDS OR FEET UNDER THE MOWER OR NEAR THE DISCHARGE CHUTE WHILE THE ENGINE IS RUNNING.**
6. **DO NOT TILT MOWER** at extreme angle while engine is running. Cut grass on hills and banks sideways.
7. **STOP THE ENGINE** when not cutting grass.
8. **DO NOT ALLOW MINORS** to operate mower unless thoroughly instructed and properly supervised.
9. **KEEP CHILDREN AND PETS AWAY** from area at all times during mowing operation.
10. **ALWAYS CHECK FOR DAMAGE** If you should strike some foreign object while mowing, stop your mower. Inspect for and repair any damage before restarting and operating the mower.
11. **ALWAYS REMOVE KEY** from switch when leaving your mower unattended or when mower is not in use.

LAWN CARE

1. It is not advisable to cut off more than 1/3 of the total length of the grass at any one mowing.
2. When mowing thick, lush wet grass, start at outside of lawn and mow in counter-clockwise direction to prevent mower from recutting clippings from previous rounds.
3. When mowing thin or dry grass, start at outside of lawn and mow in clockwise direction to progressively discharge clippings to center of lawn where they can easily be removed.
4. Recommended normal cutting heights for different types of grass:

1½ to 2½ — Med. to Med. High	Marion blue grass	1 to 1½ — Low to Med. Low.	Bermuda
1½ to 2½ — Med. to Med. High	Kentucky blue grass	1 to 1½ — Low to Med. Low.	Zoysia
1 to 2 — Med. - Low to Med.	Fescues	1 to 2 — Med. - Low to Med.	Bent grass
1 to 2 — Med. - Low to Med.	Rye grass		

USING GRASS CATCHER

1. When using grass catcher, operate mower engine at ¾ to full throttle.
2. In heavy dense turf, set cutting height in medium to high position and mow in a counter-clockwise direction so the catcher will not drag in the uncut portion.
3. Allow wet grass to dry before attempting to mow with grass catcher attached.
4. Empty catcher bag thoroughly before storage.

PREPARING YOUR YARD-MAN MOWER FOR USE

SET UP

Your mower is shipped in one carton completely assembled with the handle assembly in the shipping or storage position. To remove your mower from the carton, slit the end of the carton and roll the mower out. **DO NOT** attempt to lift the unit by the engine shroud.

To place the handle in operating position, lift the handle assembly until the lower section snaps into the operating position as shown. The upper section can now be fitted into place. Fasten the upper and lower sections together with the handle mounting knobs.

NOTE: Make sure the handle knobs are loose enough to allow the upper section to pivot freely around the mounting bolts when placing the handle in either operating or storage position.

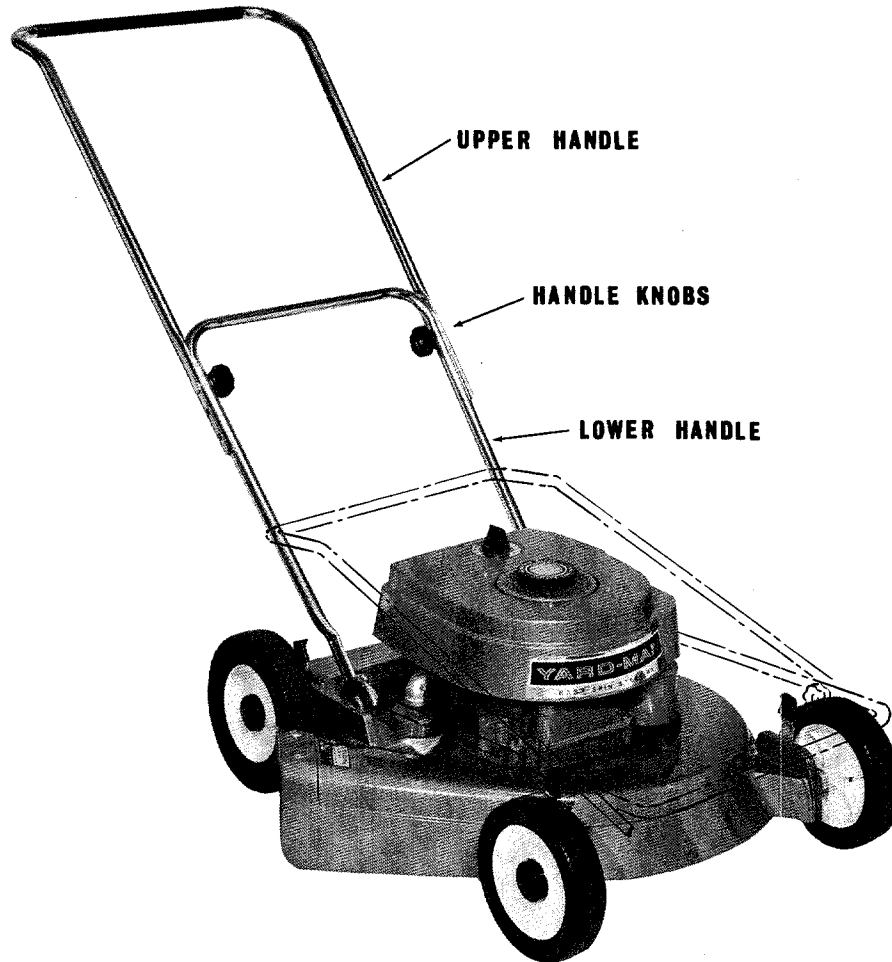

BEFORE STARTING ENGINE

Remove oil fill plug and fill the crankcase with S.A.E. No. 30 oil. (1¼ pints approx.)

Fill fuel tank with a good grade regular clean, fresh gasoline. **DO NOT MIX OIL WITH GASOLINE.** FOR COMPLETE ENGINE INFORMATION, READ ENGINE INSTRUCTION BOOKLET BEFORE STARTING ENGINE.

BATTERY CARE

It is not necessary to remove the battery except for replacement. To recharge plug the charger cord into the charger connector of the mower and into a 120V AC outlet.

NOTE: New batteries are partially charged and will require an initial charge of 20 to 24 hours to become fully charged. A 6 to 12 hour initial charge should be sufficient for a number of starts.

TO START ENGINE

1. Move throttle control to start position or midway in run position.
2. Turn key to start position and hold until the engine starts—then release.
3. When engine starts, move throttle control knob to run position (slow speed) until engine warms up.

NOTE: The fuel tank should be completely full before starting for the first time.

IMPORTANT: If engine floods, place throttle control knob in "Start" position and turn the engine over for about four or five seconds. Then reposition control lever to "Run" position and start engine.

Engine flooding is usually caused by a dirty air cleaner. Service air cleaner regularly as noted in engine operation and maintenance instruction.

If engine continues to flood even with a clean air filter, lean carburetor adjustment screw 1/8 turn (See engine instructions)

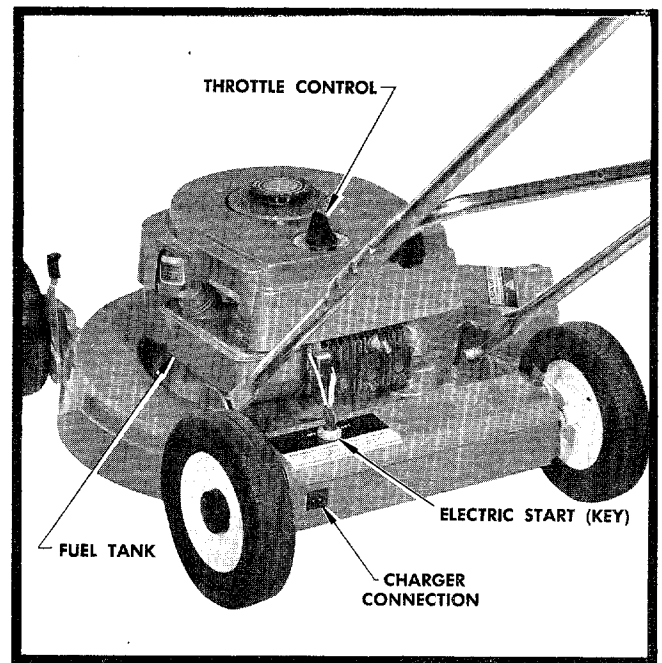

TO STOP ENGINE

To stop the engine, turn key to "OFF" position. The engine may also be stopped by moving throttle control to "STOP" position.

TIPS TO OBTAIN BEST ELECTRIC STARTER PERFORMANCE

- a. Short starting cycles (2 to 3 seconds) provide the longest battery life.
- b. Keep the battery fully charged. This assures quick, and easy starts. (See Pg. 3)
- c. Start engine with mower on sidewalk or driveway where the cutting blades are out of the grass in an unloaded condition. If starts must be made on the lawn, move mower over previously cut grass
- d. Keep the underside of the mower deck clean. Periodically scrape or wash away any built up grass which might add resistance to the cutter blade and electric starting system. (See Pg. 6 for instructions on use of wash out port.)

AUXILIARY ROPE STARTER can be used to start the engine if the batteries run low, or if the engine cannot be started electrically. Remove the plastic cover as shown. Place engine control in "FAST" and key in "On" position. Place rope knot in the impression and wind rope clockwise around pulley and over the knot holding it in place. Pull rope rapidly. Repeat if necessary. (NOTE: Auxiliary starter rope is supplied with your mower.)

CAUTION

Always remove the key from the switch when leaving your mower unattended or when mower is not in use.

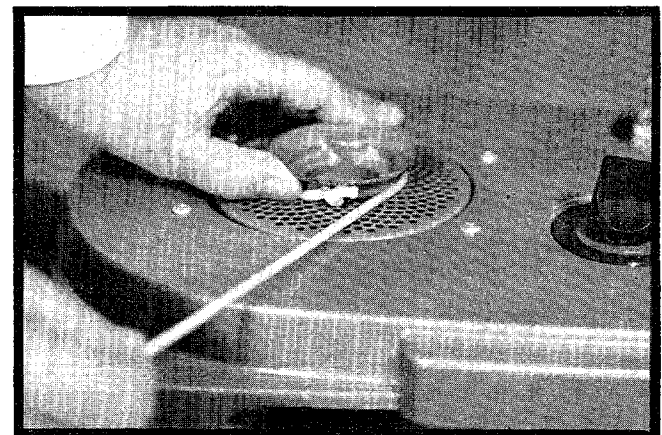
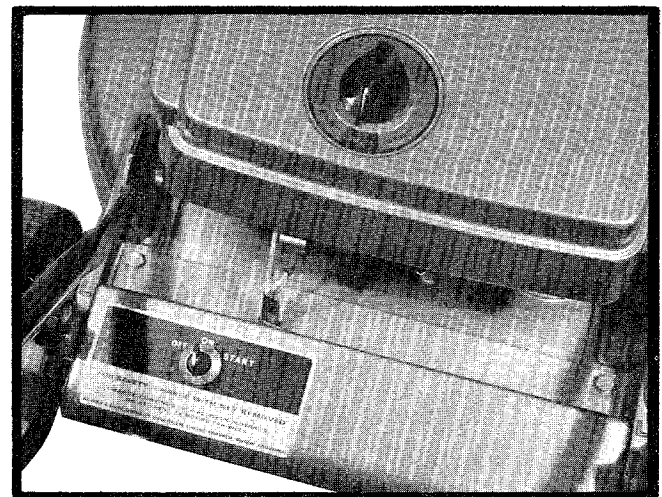

SUGGESTIONS FOR MORE EFFICIENT, AND MAINTENANCE-FREE OPERATION

GENERAL MOWING

1. Always keep mower blade "Knife" sharp and balanced for maximum cutting efficiency.
2. Always start engine with mower on level surface where blade will not drag on tall grass or other obstructions. After starting, let engine warm up several minutes at slow speed before starting to mow.
3. When mowing under normal conditions, run mower at 1/2 to 3/4 throttle for best results.
4. When cutting tall heavy growth, or on rough ground, place mower in highest cut position and gradually reduce to desired cutting height over course of two or three mowings.

MAINTENANCE

Your mower like all machines with moving parts must receive care and maintenance. The following tips, if used, will contribute many trouble-free hours to your mower.

1. Check oil level frequently. When checking or changing oil, make sure dirt and debris is cleaned off oil sump before removing oil plug.
2. Keep mower clean, especially the engine and underside of mower housing. See washout port on Pg. 6.
3. Check all nuts, bolts and screws occasionally to be sure mower is in good operating condition.
4. Should excessive vibration develop, check your blade and crankshaft immediately. Do not operate mower with an unbalanced blade, a damaged blade or a damaged crankshaft.
5. The wheel bearings are pre-lubricated at the factory and should require no further attention until mower is serviced.
6. If you are going to store your mower for any length of time (30 days or longer) it is important that the following steps be taken:
 - a. Drain the gas tank. Start the engine and allow it to run out of gas. Gasoline left in the engine will leave gum deposits in the carburetor and gas tank.
 - b. Clean engine of all foreign matter.
 - c. Lubricate cylinder by removing the sparkplug and pouring one ounce of clean lubricating oil through the sparkplug hole into the cylinder. Crank engine slowly to spread oil and replace sparkplug. To start after storage remove sparkplug and rotate engine with starter to remove excess oil.
7. Just as your automobile needs professional mechanical maintenance from time to time, so does your air cooled engine. A yearly tune-up and check by a qualified Service Center is recommended to avoid breakdowns and unnecessary delays during the cutting season.

TO RECHARGE BATTERY

Plug the charger cord into a 120V AC outlet to recharge. It is not possible to overcharge the battery and as current demand is extremely low, leave the charger connected as much as possible during the entire mowing season.

NOTE: If the temperature is below 40°F move the battery to a warmer area before charging. As this battery will not freeze, it is not necessary to maintain a charge except during the mowing season.

TO ADJUST HEIGHT OF CUT

The cutting height of your mower can easily be adjusted from low to high cut. Place your hand on the outside of the wheel, spring the adjusting lever, with your thumb, outward until the locating trunnion on the lever is free from the housing. Move the wheel and lever to the height of cut desired. Release the lever, allowing the trunnion to drop into the proper locating hole. Each wheel must be set at the same height.

CAUTION: Do not make adjustments with the engine running.

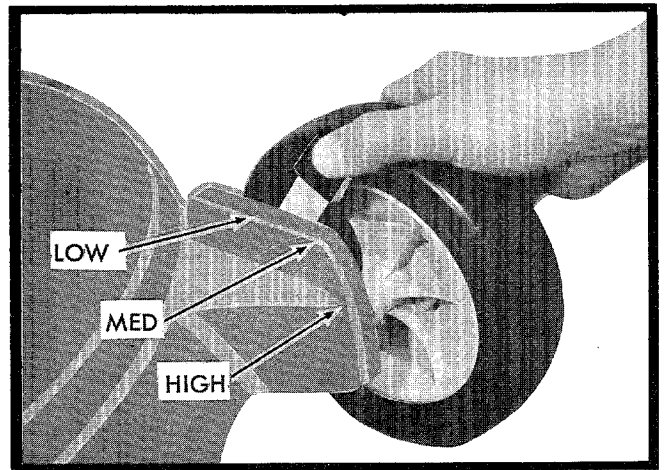

TO CHANGE OIL

Engine oil should be changed after the first 5 hours of operation and each 25 hours of operation thereafter.

Drain oil while engine is warm. Disconnect spark plug wire and secure at least 1" away from spark plug. Block right hand side of mower up about 4" high and set shallow one quart container beneath oil drain. Remove oil drain plug from sump and allow oil to drain completely. Replace plug and refill with S.A.E. #30 oil. (1¼ pints approx.)

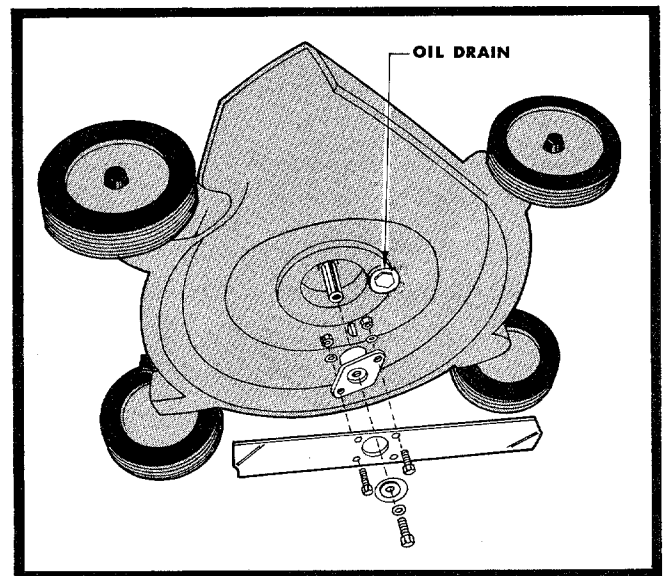

TO REPLACE BLADE

1. Be sure engine is stopped, disconnect spark plug wire and secure at least 1" away from spark plug.
2. Tip mower on the side and remove the blade and adaptor from engine crank.
3. Remove the blade from the adaptor and replace with a new blade. Reassemble to engine.
4. Resharpenering of an old blade should only be attempted by a qualified Service Center. This way proper blade balance will be maintained.

BREAK-IN PERIOD

During the first ten hours of operation, check the following items frequently:

- Oil Level
- All nuts, bolts and screws for tightness
- Condition of Blade

TO USE WASH OUT PORT

After mowing, place hose end (without nozzle) into opening located next to discharge chute. Using moderate water pressure, run engine at full throttle speed for about two minutes. This flushes out accumulations of grass clippings from underneath mower housing. DO NOT wash the top. It may be necessary to tilt the mower back on the rear wheels after washing to drain any water which may have accumulated on the top of the housing.

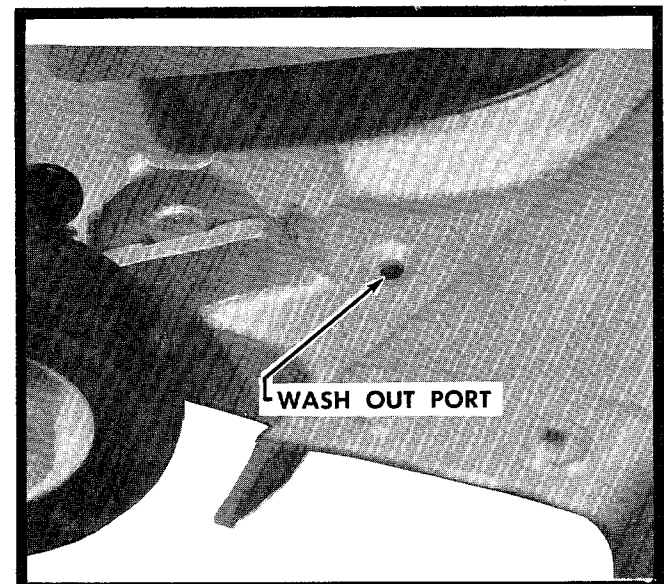

MODEL 2320-2

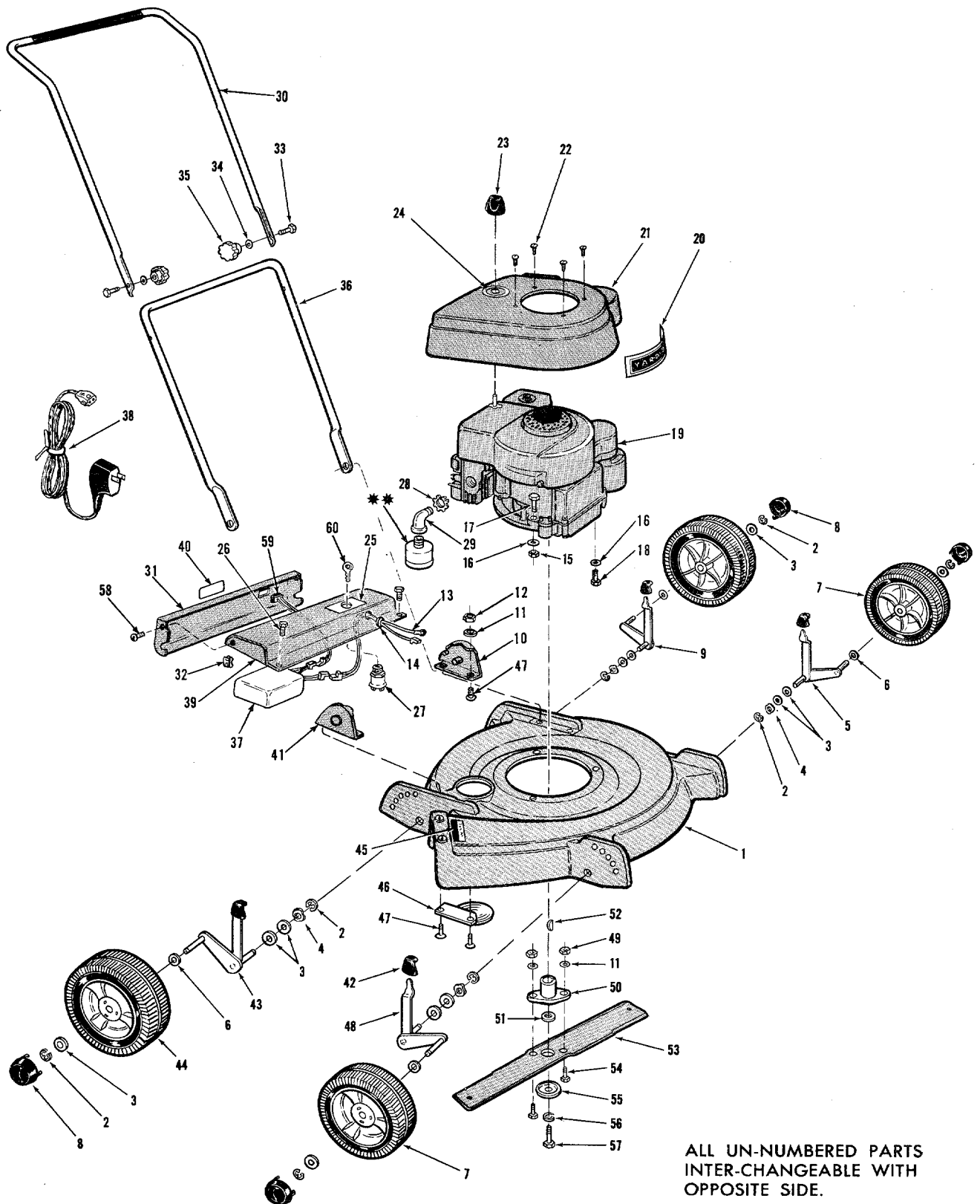

For Parts List—See Pg. 9

*** Engine Part—Refer to Engine Model and Type.

PARTS LIST

MODEL 2320-2

Your cutting unit is right hand (R.H.) or left hand (L.H.) as you cut.

REF. NO.	PART NO.	NAME OF PART	REF. NO.	PART NO.	NAME OF PART
1	3601-123-55	Blade Housing	31	3677-28-55	Shield—Battery Case
2	1650-1	Retaining Ring	32	1539-8	Nut (Special)
3	1540-90	*Washer (½ x 1.0 x .030)	33	1513-103	Bolt (5/16-18 x 1¾ Special)
4	1552-2	*Washer—Wave	34	1025	Washer—Lock (5/16 Split)
5	2123-31	Ass'y—Front Axle (L.H.)	35	1643-47	Knob—Hand
6	1540-86	Washer (½ I.D. x 1.0 O.D. x ⅛)	36	3712-83-01	Handle—Lower
7	2108-183-41	Ass'y—Wheel & Tire (7 x 1.75)	37	2721-8	Battery
8	2674-39-40	Hub Cap	38	1772-1	Ass'y—Battery Charger
9	2123-33	Ass'y—Rear Axle (L.H.)	39	2118-59-55	Ass'y—Cover & Clips
10	2132-87-55	Ass'y—Bracket & Pin (L.H.)	40	1605-514	Name Plate
11	1018	*Washer—Lock (¼ Split)	41	2132-86-55	Ass'y—Bracket & Pin (R.H.)
12	1538-19	*Nut (¼-20 Hex Lock)	42	2643-43	Knob—Adjust Lever
13	2188-10	Ass'y—Wire Harness	43	2123-32	Ass'y—Rear Axle (R.H.)
14	1657-44	Bushing (Grommet)	44	2108-187-41	Ass'y—Wheel & Tire (8 x 1,75)
15	1538-6	*Nut—Lock (5/16-18 Hex)	45	1616-343	Label—Caution
16	159	Washer (5/16 x ⅝ x 1/16)	46	2556-18	Deflector—Muffler
17	1509-75	*Bolt (5/16-18 x 1½ Hex Hd.)	47	1529-15	*Bolt (¼-20 x ⅝ Carriage)
18	1513-56	Bolt (⅜-16 x 1¼ Special)	48	2123-30	Ass'y—Front Axle (R.H.)
19		Ass'y—Engine Briggs & Stratton Model 92905 Type 0840-01	49	1538-8	*Nut (¼-20 Hex Hd. Lock)
20	2616-434	Label—Engine Shroud	50	1143-5-55	Ass'y—Blade Adaptor
21	3699-89-55	Shroud—Engine	51	1624-135	Washer (⅜ x 1 x .210)
22	1526-1	Screw—Shroud Retaining	52	1646-8	Key (#6 Woodruff)
23	2643-44	Knob—Throttle Control	53	3604-39-55	Blade—Grass
24	1616-297	Label—Dial Control	54	1509-34	*Bolt (¼-20 x ¾ Hex Hd.)
25	1616-480	Label—Key Switch	55	1543-39	Washer (Special)
26	1511-33	Bolt (¼-20 x ½ Thd. Cutting)	56	1542-8	*Lockwasher (⅜ Split)
27	2160-11	Switch—Electric Start	57	1509-101	*Bolt (⅜-24 x 1½ Hex Hd. Lock)
28	1539-67	Nut—Elbo Retaining	58	117	Screw (10-32 x 7/16 Ph. Hd.)
29	1756-4-17	Elbo—Exhaust	59	1188-42	Ass'y—Extension Wire
30	2117-86	Ass'y—Handle, Upper	60	1646-38	Key—Ignition

*Standard Hardware Item—Purchase Locally

Service Record

DATE	DESCRIPTION

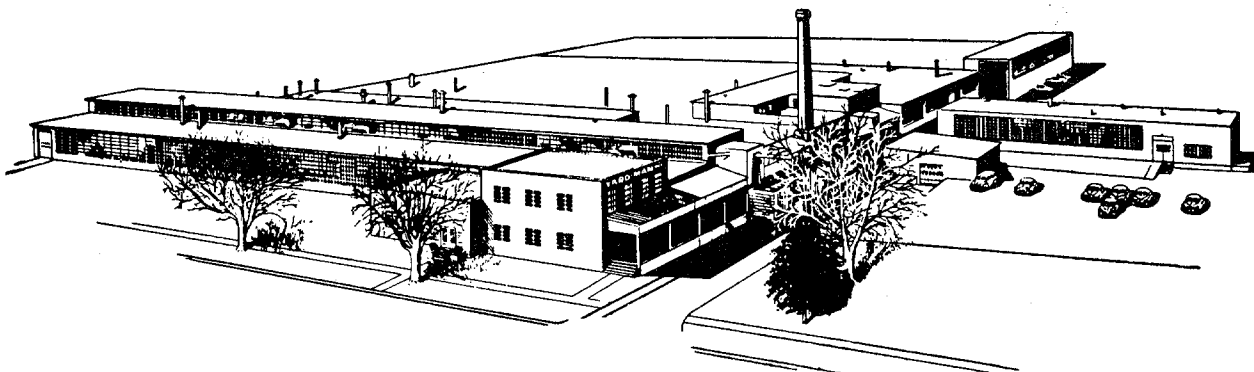

" You are cordially invited to visit
our plant at any time."

WARRANTY

This YARD-MAN unit is guaranteed for one year from date of purchase (90 days when used commercially) against defects in workmanship or material under normal use and service.

We agree to repair or replace without charge to the purchaser, including labor, any part proven to be defective within the warranty period, except the Engine which is the responsibility of the Engine manufacturer.

Parts for this YARD-MAN unit will be available for at least ten years from the date of purchase. This warranty will not apply to a unit which has been subjected to—misuse, negligence, an accident, or to a unit which has been altered in any way.

YARD-MAN

JACKSON, MICHIGAN