

YARD-MAN

OUTDOOR POWER EQUIPMENT
for all seasons



Spring

Summer



Fall

Winter



Owner's Manual

- ASSEMBLY
- OPERATION
- MAINTENANCE

IMPORTANT:
Read Safety Rules and
Instructions Carefully

18 H.P. and 20 H.P. HYDROSTATIC TRACTORS

Thank you for purchasing an American-built product.

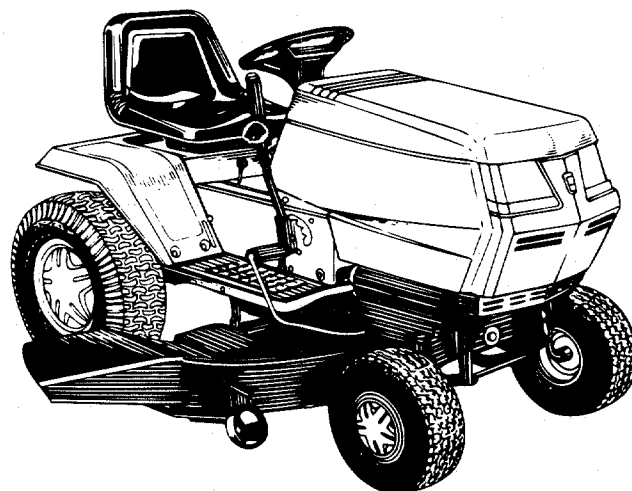

Model Numbers
144V834H401
144W834P401

WARNING: This unit is equipped with an internal combustion engine and should not be used on or near any unimproved forest-covered, brush-covered or grass-covered land unless the engine's exhaust system is equipped with a spark arrester meeting applicable local or state laws (if any). If a spark arrester is used, it should be maintained in effective working order by the operator.

In the State of California the above is required by law (Section 4442 of the California Public Resources Code). Other states may have similar laws. Federal laws apply on federal lands. A spark arrester for the muffler is available through your nearest engine authorized service dealer or contact the service department, P.O. Box 368022, Cleveland, Ohio 44136-9722.

IMPORTANT

SAFE OPERATION PRACTICES



THIS SYMBOL POINTS OUT IMPORTANT SAFETY INSTRUCTIONS WHICH, IF NOT FOLLOWED, COULD ENDANGER THE PERSONAL SAFETY AND/OR PROPERTY OF YOURSELF AND OTHERS. READ AND FOLLOW ALL INSTRUCTIONS IN THIS MANUAL BEFORE ATTEMPTING TO OPERATE YOUR UNIT. WHEN YOU SEE THIS SYMBOL—  **HEED ITS WARNING.**



DANGER: This cutting machine is capable of amputating hands and feet and throwing objects. Failure to observe the following safety instructions could result in serious injury or death.

I. GENERAL OPERATION

1. Read, understand, and follow all instructions in the manual and on the machine before starting. Keep this manual in a safe place for future reference and for ordering replacement parts.
2. Only allow responsible adults familiar with the instructions to operate the machine. Know controls and how to stop the machine quickly.
3. Do not put hands or feet under cutting deck or near rotating parts.
4. Clear the area of objects such as rocks, toys, wire, etc. which could be picked up and thrown by the blade. A small object may have been overlooked and could be accidentally thrown by the mower in any direction and cause injury to you or a bystander. Always wear safety glasses or eye shields during operation or while performing an adjustment or repair, to protect eyes from foreign objects. Stop the blade(s) when crossing gravel drives, walks or roads.
5. Be sure the area is clear of other people before moving. Stop machine if anyone enters the area.
6. Never carry passengers.
7. Disengage blade(s) before shifting into reverse and backing up. Always look down and behind before and while backing.
8. Be aware of the mower and attachment discharge direction and do not point it at anyone. Do not operate the mower without either the entire grass catcher or the chute guard in place.
9. Slow down before turning. Operate the tractor smoothly. Avoid erratic operation and excessive speed.
10. Never leave a running machine unattended. Always turn off blade(s), place transmission in neutral, set park brake, stop engine and remove key before dismounting.
11. Turn off blade(s) when not mowing.
12. Stop engine and wait until blade(s) comes to a complete stop before (a) removing grass catcher or unclogging chute, or (b) making any repairs, adjusting or removing any grass or debris.
13. Mow only in daylight or good artificial light.
14. Do not operate the machine while under the influence of alcohol or drugs.
15. Watch for traffic when operating near or crossing roadways.
16. Use extra care when loading or unloading the machine into a trailer or truck. This unit should not be driven up or down a ramp onto a trailer or truck under power, because the unit could tip over, causing serious personal injury. The unit must be pushed manually to load or unload properly.
17. Never make a cutting height adjustment while engine is running if operator must dismount to do so.
18. Wear sturdy, rough-soled work shoes and close-fitting slacks and shirts. Do not wear loose fitting clothes or jewelry. They can be caught in moving parts. Never operate a unit in bare feet, sandals, or sneakers.
19. Check overhead clearance carefully before driving under power lines, wires, bridges or low hanging tree branches, before entering or leaving buildings, or in any other situation where the operator may be struck or pulled from the unit, which could result in serious injury.
20. Disengage all attachment clutches, thoroughly depress the brake pedal, and shift into neutral before attempting to start engine.

II. SLOPE OPERATION

Slopes are a major factor related to loss of control and tip-over accidents which can result in severe injury or death. All slopes require extra caution. If you cannot back up the slope or if you feel uneasy on it, do not mow it.

DO:

Mow up and down slopes, not across.

Remove obstacles such as rocks, limbs, etc.

Watch for holes, ruts or bumps. Uneven terrain could overturn the machine. **Tall grass can hide obstacles.**

Use slow speed. Choose a low enough gear so that you will not have to stop or shift while on the slope. Always keep tractor in gear when going down slopes to take advantage of engine braking action.

Follow the manufacturer's recommendations for wheel weights or counterweights to improve stability.

Use extra care with grass catchers or other attachments. These can change the stability of the machine.

Keep all movement on the slopes **slow** and **gradual**. Do not make sudden changes in speed or direction. Rapid engagement or braking could cause the front of the machine to lift and rapidly flip over backwards which could cause serious injury.

Avoid starting or stopping on a slope. If tires lose traction, disengage the blade(s) and proceed slowly **straight** down the slope.

For your safety, use the slope gauge included as part of this manual to measure slopes before operating this unit on a sloped or hilly area. If the slope is greater than 15° as shown on the slope gauge, do not operate this unit on that area or serious injury could result.

DO NOT:

Do not turn on slopes unless necessary; then, turn slowly and gradually downhill, if possible.

Do not mow near drop-offs, ditches or embankments. A wheel over the edge or an edge caving in could cause sudden overturn.

Do not mow on wet grass. Reduced traction could cause sliding.

Do not try to stabilize the machine by putting your foot on the ground.

Do not use grass catcher on steep slopes.

III. CHILDREN

Tragic accidents can occur if the operator is not alert to the presence of children. Children are often attracted to the machine and the mowing activity. **Never** assume that children will remain where you last saw them.

1. Keep children out of the mowing area and in watchful care of an adult other than the operator.

2. Be alert and turn machine off if children enter the area.

3. Before and when backing, look behind and **down** for small children.

4. Never carry children. They may fall off and be seriously injured or interfere with the safe machine operation.

5. Never allow children under 14 years old to operate the machine. Children 14 years and over should only operate machine under close parental supervision and proper instruction.

6. Use extra care when approaching blind corners, shrubs, trees or other objects that may obscure vision.

(continued on page 5)

USE THIS SHEET AS A GUIDE TO DETERMINE SLOPES WHERE YOU MAY NOT OPERATE SAFELY.

SLOPE GAUGE

(Keep this sheet in a safe place for future reference.)

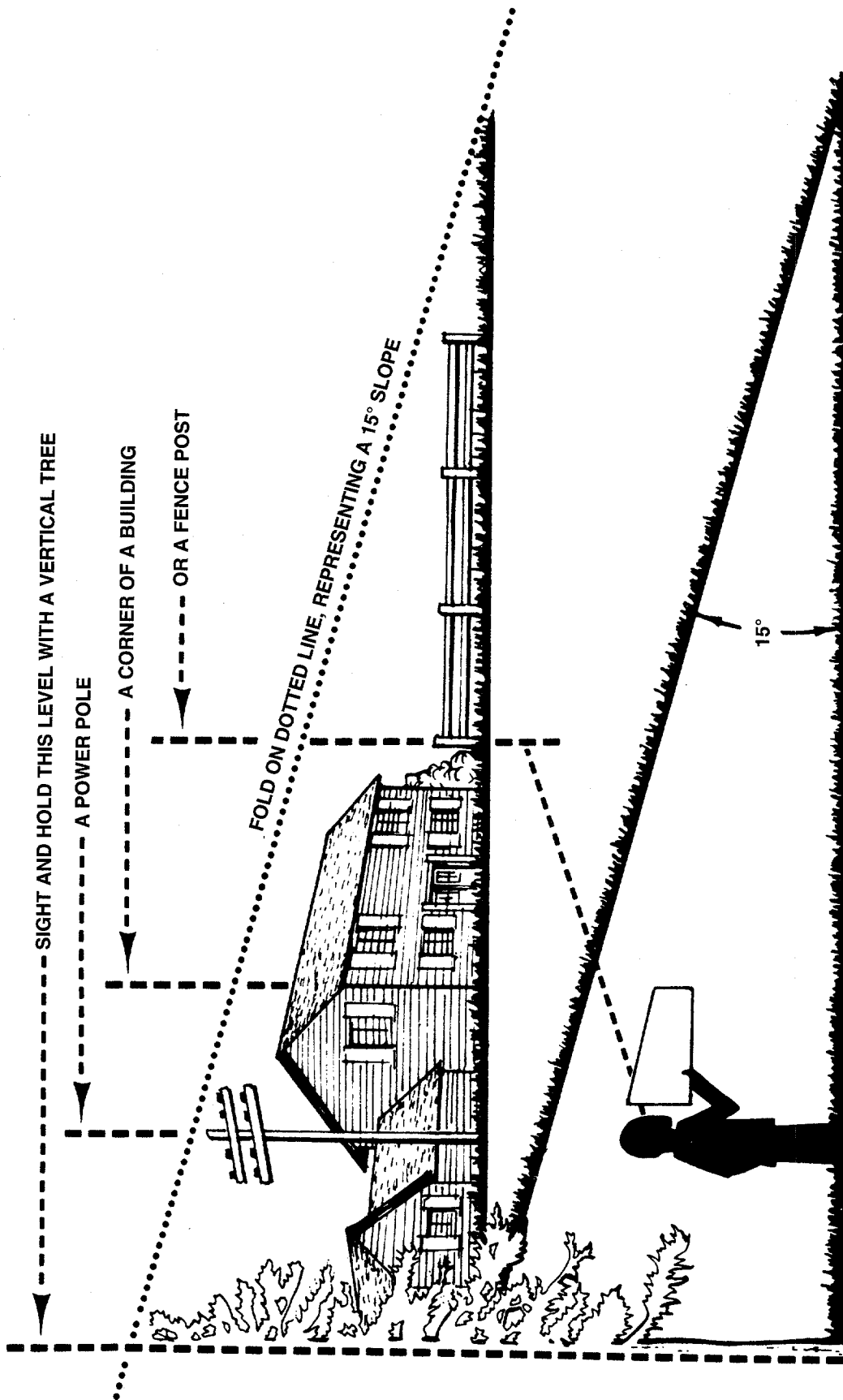

Do not mow on inclines with a slope in excess of 15 degrees (a rise of approximately 2-1/2 feet every 10 feet). A riding mower could overturn and cause serious injury. If operating a walk-behind mower on such a slope, it is extremely difficult to maintain your footing and you could slip, resulting in serious injury.

Operate RIDING mowers up and down slopes, never across the face of slopes.

Operate WALK-BEHIND mowers across the face of slopes, never up and down slopes.

CONTENTS OF HARDWARE PACK

Remove this sheet from your owner's manual and lay the hardware on the illustration for identification purposes. Refer to the separate deck manual for any information concerning the deck. After assembly, keep the Slope Gauge which is on the reverse side of this sheet for future use.

(Hardware pack may contain extra items which are not used on your unit.
Part numbers are shown in parentheses.)

A STEERING WHEEL INSTALLATION

Hex Lock Nut
5/16-24 Thread
(712-0237)



Cupped Washer
5/16" I.D.
(736-0242)

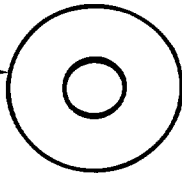

Steering Wheel
Insert
Is Not Shown

Steering
Bellow
(731-0954)

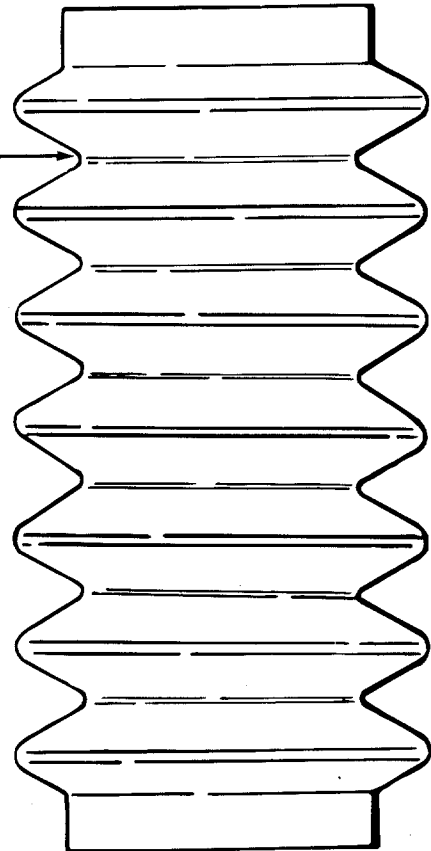

B ATTACHING THE DECK LINKS



Eyebolts
(711-0817)
(Not Shown to Scale)

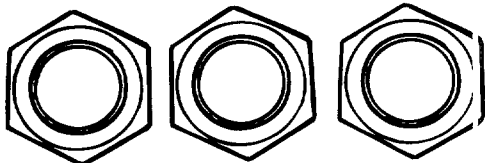

Hex Nuts
1/2-13 Thread
(712-0206)

C FINAL ASSEMBLY

Mounting Clips
(727-0425A)
Quantity—20



D IGNITION KEYS

Not Shown—
(May be
Attached to
Tractor)

Cut Along This Line



IV. SERVICE

1. Use extra care in handling gasoline and other fuels. They are flammable and vapors are explosive.
 - a. Use only an approved container.
 - b. Never remove gas cap or add fuel with the engine running. Allow engine to cool at least two minutes before refueling. Do not smoke.
 - c. Never refuel the machine indoors.
 - d. Never store the machine or fuel container inside where there is an open flame, or spark, such as a water heater, space heater, clothes dryer and the like.
2. Never run a machine inside a closed area.
3. Check frequently and keep nuts and bolts, especially blade attachment bolts, tight and keep equipment in safe working condition.
4. Never tamper with safety devices. Check their proper operation regularly. Use all guards as instructed in this manual.
5. To reduce fire hazard, keep machine free of grass, leaves or other debris build-up. Clean up oil or fuel spillage. Allow machine to cool before storing.
6. Stop and inspect the equipment for damage if you strike an object. Repair, if necessary, before re-starting and operating the machine.
7. Never make adjustments or repairs with the engine running.
8. Grass catcher components are subject to wear, damage and deteriorate, which could expose moving parts or allow objects to be thrown. Frequently, check components and replace with manufacturer's recommended parts when necessary.
9. Mower blades are sharp and can cut. Wrap the blade(s) or wear gloves and use extra caution when servicing blade(s).
10. Check brake operation frequently. Adjust and service as required.
11. Muffler, engine, and belt guards become hot during operation and can cause a burn. Allow to cool down before touching.
12. Do not change the engine governor settings or overspeed the engine.



DANGER: Your unit was built to be operated according to the rules for safe operation in this manual. As with any type of power equipment, carelessness or error on the part of the operator can result in serious injury. If you violate any of these rules, you may cause serious injury to yourself or others.

ASSEMBLY INSTRUCTIONS

IMPORTANT: After assembly, service engine with gasoline, and check oil level as instructed in the separate engine manual. Do not overfill.

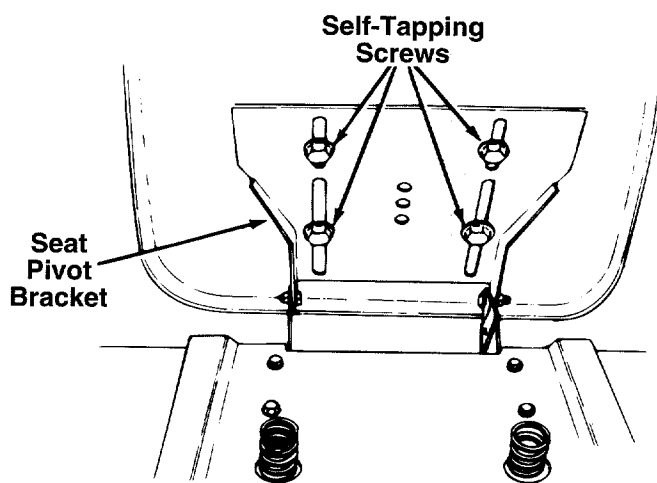

FIGURE 1.

NOTE: Reference to right or left hand side of the unit is observed from the driver's seat, facing forward. Refer to the separate deck manual for all information regarding the deck.

UNPACKING

1. Remove the carton from the tractor as follows. Open the top flaps and remove all carton inserts. Carefully cut on dotted line all the way around the carton. Lift the carton off the tractor. Remove the deck from beneath the tractor. Roll the tractor off the skid. Make certain all parts and literature have been removed from the carton before the carton is discarded.
2. Remove page four from this manual and lay the contents of the hardware pack according to the illustration for identification.

SEAT ASSEMBLY

Remove the four hex self-tapping screws from the bottom of the seat. Place the seat in position against the seat pivot bracket, lining up the slotted holes in the seat with the holes in the seat. Select desired position for the seat, and secure with hex self-tapping screws. See figure 1.

BATTERY INFORMATION



WARNING

- A. Battery acid must be handled with great care as contact with it can burn and blister the skin. It is also advisable to wear protective clothing (goggles, rubber gloves and apron) when working with it.*
- B. Should battery acid accidentally splatter into the eyes or onto the face, rinse the affected area immediately with clean, cold water. If there is any further discomfort, seek prompt medical attention.
- C. If acid spills on clothing, first dilute it with clean water, then neutralize with a solution of ammonia/water or baking soda/water.
- D. Since battery acid is corrosive, do not pour it into any sink or drain. Before discarding empty electrolyte containers, rinse them with a neutralizing solution.
- E. NEVER connect or disconnect charger clips to battery while charger is turned on as it can cause sparks.
- F. Keep all lighted materials (cigarettes, matches, lighters) away from the battery as the hydrogen gas generated during charging can be combustible.
- G. As a further precaution, only charge the battery in a well-ventilated area.
***Always shield eyes, protect skin and clothing when working near batteries.**

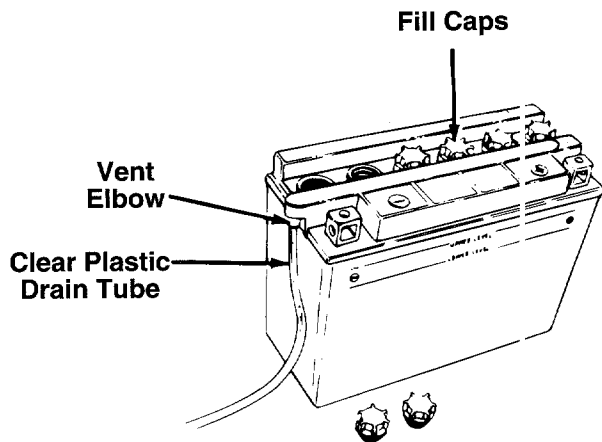

FIGURE 2.

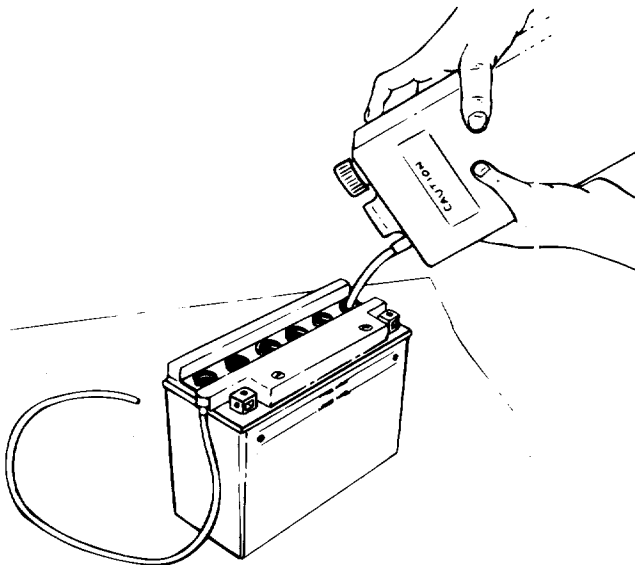

FIGURE 3.

ACTIVATING THE BATTERY

Do not activate battery (fill with battery acid) until battery is actually placed in service. Be certain to read previous warnings before activating the battery.

1. Open the battery pack. Be careful not to puncture the box. It contains the **battery fluid (acid)** in a plastic container and one short plastic tube.
2. Remove the battery from the tractor by lifting the hood and removing the wing nuts and battery cover.
3. Place the battery on a table or workbench. Make certain the long plastic drain tube is in place on the vent elbow.
4. Remove the six fill caps from the top of the battery. See figure 2.
5. Place the battery fluid container on the table or workbench. Carefully cut off tip of the spout and attach the short plastic tube provided. Do not squeeze the container when cutting tip.
6. Fill each battery cell slowly and carefully to the UPPER LEVEL line marked on battery. See figure 3. Use caution as the acid level will rise rapidly after the bottom of the cell is filled.
7. **Allow battery to stand for 30 minutes** with the fill caps removed, while the plates absorb acid.

NOTE: You can continue assembling the tractor while battery is standing for 30 minutes (after filling with acid), and later while you are charging the battery.

CHARGE THE BATTERY

IMPORTANT: To obtain the maximum life from your battery, it **MUST BE CHARGED** prior to initial use.

1. Check the acid level in each cell. If necessary, refill each cell with **battery acid** to the UPPER LEVEL line on battery. Replace the fill caps.
2. Before discarding the empty container, neutralize any residue with baking soda and rinse container with water. Puncture container several times before discarding.
3. **CHARGE THE BATTERY** after the 30 minute standing period. Use a 12-volt automotive type battery charger to SLOW CHARGE THE BATTERY (DO NOT FAST CHARGE). DO NOT use a charger rated higher than 10 amps. **Charge the battery** for a minimum of 2 hours or until battery is fully charged.

NOTE: The information listed above is for initial charge. Refer to the Maintenance section of this manual for battery care and charging instructions to obtain the maximum life from your battery.

IMPORTANT: After battery has been charged, add only distilled water. DO NOT add acid.



DANGER

Battery contains sulfuric acid. Refer to warning on page 5. Antidote: EXTERNAL—Flush with water. INTERNAL—Drink large quantities of water or milk. Follow with milk of magnesia, beaten egg or vegetable oil. Seek prompt medical attention. EYES: Flush with cool water for at least 15 minutes, then seek immediate medical attention.

Since batteries produce explosive gases, keep all lighted materials (cigarettes, lighters, matches, etc.) away. Be sure to charge battery only in well-ventilated areas.

**KEEP BATTERIES
OUT OF THE REACH OF CHILDREN!!**

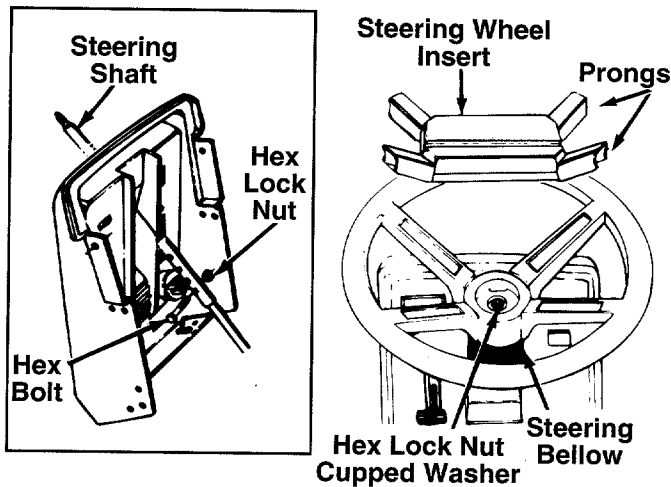

FIGURE 4.

STEERING WHEEL INSTALLATION (Hardware A)

1. There are four height positions for the steering wheel. For shipping purposes, the steering shaft is assembled in the lowest position. Lift the hood of the tractor. Remove the hex bolt and hex lock nut on the steering shaft. Raise the shaft to desired position and secure with hex bolt and hex lock nut. See figure 4.
2. Attach one end of the plastic steering bellow to the steering wheel as shown in figure 4.
3. Position the front wheels of the tractor so they are pointing straight forward.
4. Place the steering wheel (with steering bellow attached) over the steering shaft extending through the dash, positioning steering wheel as desired.
5. Place the washer with the cupped side down over the steering shaft. Secure with 5/16" hex lock nut. See figure 4.
6. Place the steering wheel insert over the center of the steering wheel, and press on by hand.

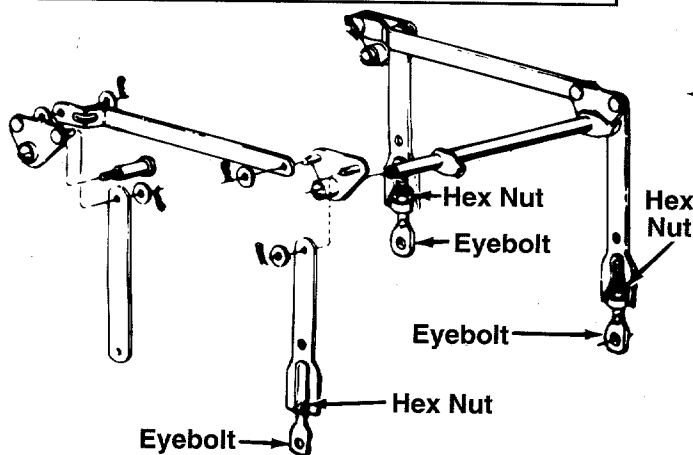
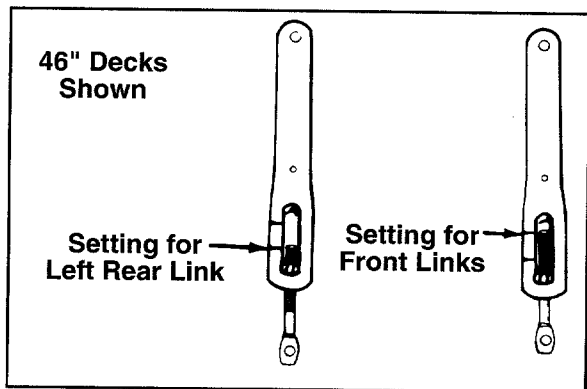

FIGURE 5.

ATTACHING THE DECK LINKS (Hardware B)

The three adjustable deck links have been shipped unassembled. Attach as follows.

1. Start 1/2" hex nuts on eyebolts provided. Insert the hex nuts and eyebolts into the adjustable lift links as shown in figure 5.
2. Thread eyebolts into the lift links and hex nuts. The left rear link should be adjusted so the eyebolt is to the **lower** mark as shown. The two front links should be adjusted to the **higher** mark.

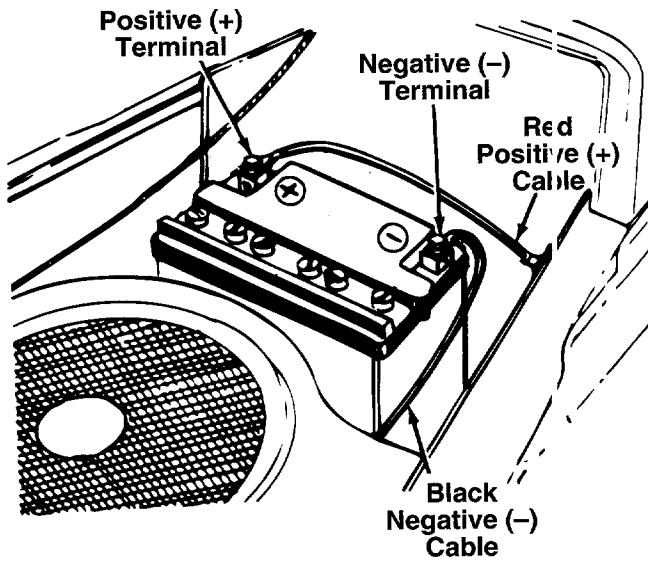

FIGURE 6.

INSTALLING THE BATTERY

1. Place the battery on the battery plate with the terminals toward the rear of the tractor.
2. Remove the hex bolt and hex nut from each battery terminal.
3. Attach the positive cable (heavy red wire) to the positive battery terminal (+) with one hex bolt and hex nut. See figure 6.

NOTE: The positive battery terminal is marked Pos. (+). The negative battery terminal is marked Neg. (-).

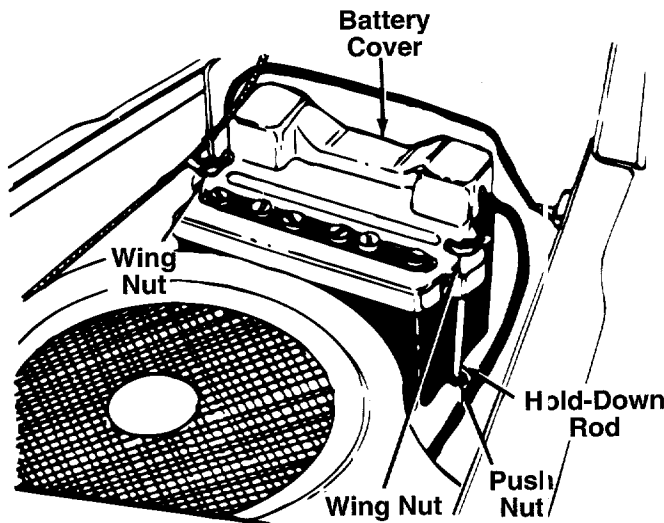

FIGURE 7.

4. Attach the negative cable (heavy black wire) to the negative battery terminal (-) with the other hex bolt and hex nut.
5. Place the black plastic battery cover in position over the hold-down rods. Secure with wing nuts.

NOTE: It may be necessary to pull up on the hold-down rods in order to start the wing nuts.

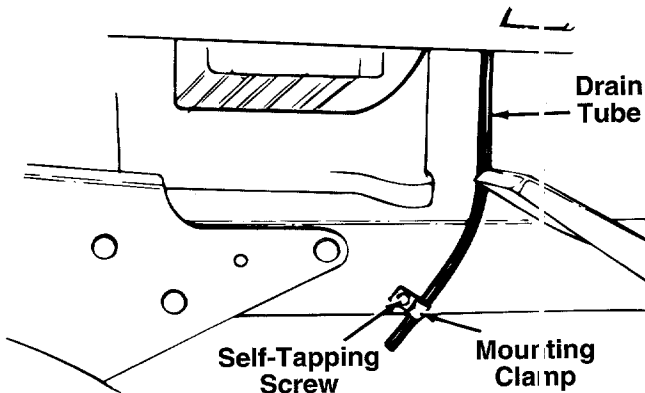

FIGURE 8.

6. Route the battery drain tube over to the **left** side of the tractor. Loosen the self-tapping screw which secures the mounting clamp. See figure 8. Slip the end of the drain tube into the mounting clamp. Tighten the self-tapping screw to secure the clamp. Do not overtighten which could collapse the drain tube.

NOTE: The vented battery allows any gases or liquid from the battery to be drained onto the ground.

7. Trim end of drain tube if more than 1 inch extends below the frame.

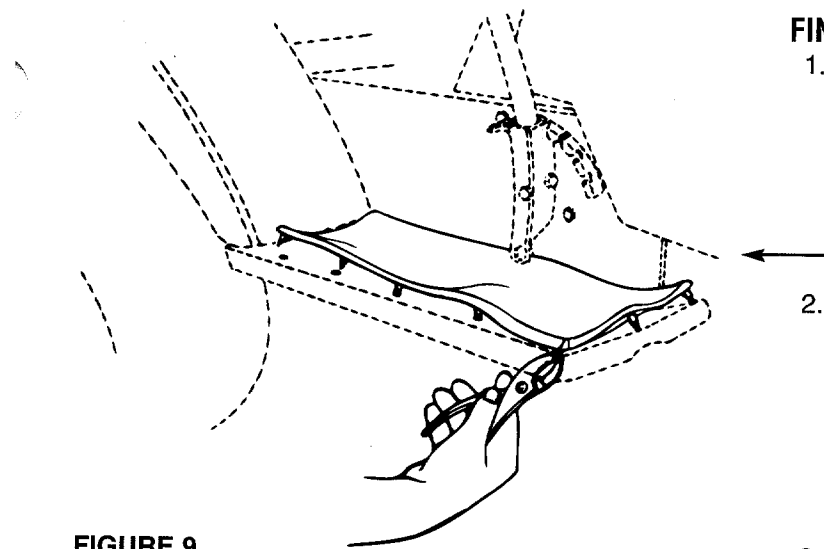

FIGURE 9.

FINAL ASSEMBLY (Hardware C)

1. If not already assembled, attach foot pads as follows. Position one foot pad on top of the running board on the tractor, lining up the studs on the bottom of pad with the holes in the running board. Pull the studs through the holes in the running board using a pair of pliers. Repeat on other side of tractor. See figure 9.
2. If not already assembled, attach the four hub caps as follows.
 - a. Slide five mounting clips on each hub cap as shown in figure 10, with the tabs on the mounting clips facing outward.
 - b. Line up hub caps with wheel rims. Push hub caps on by hand.
3. Make certain **all** nuts and bolts are tightened securely.

TIRE PRESSURE

The tires on your unit may be over-inflated for shipping purposes. Reduce the tire pressure before operating the unit. Recommended operating tire pressure is approximately 12 p.s.i. (check sidewall of tire for tire manufacturer's recommended pressure).



WARNING: Maximum tire pressure under any circumstances is 30 p.s.i. Equal tire pressure should be maintained on all tires.

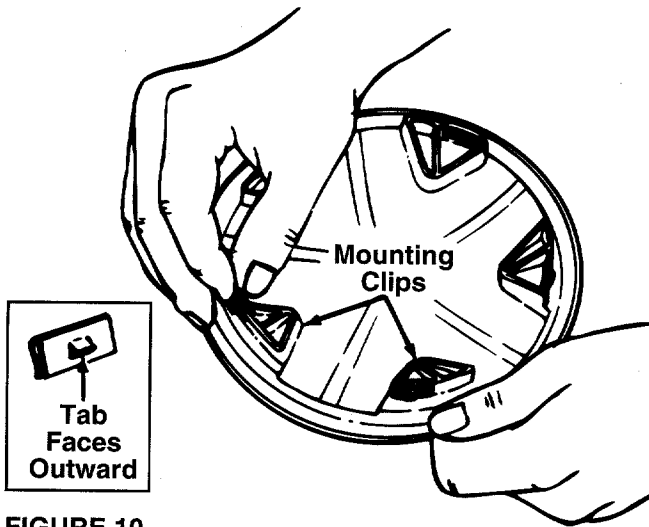

FIGURE 10.

ATTACHING THE CUTTING DECK

Attach the cutting deck as instructed in the separate deck manual packed with your unit.

CONTROLS

IGNITION SWITCH

The ignition switch is located on the dashboard. Turn the key to the START position to start the engine. When the engine is running, leave the key in the ON position. To stop the engine, turn the key to the OFF position. See figure 11.



WARNING: Remove the key from the tractor when the tractor is not in use to prevent accidental starting.

THROTTLE CONTROL

The throttle control is located on the left side of the dashboard and is used to regulate the engine speed. See figure 11. The engine should be operated from 3/4 to full throttle (FAST) when operating any equipment that uses the tractor engine as a source of power such as the mowing deck, snow thrower or rotary tiller.

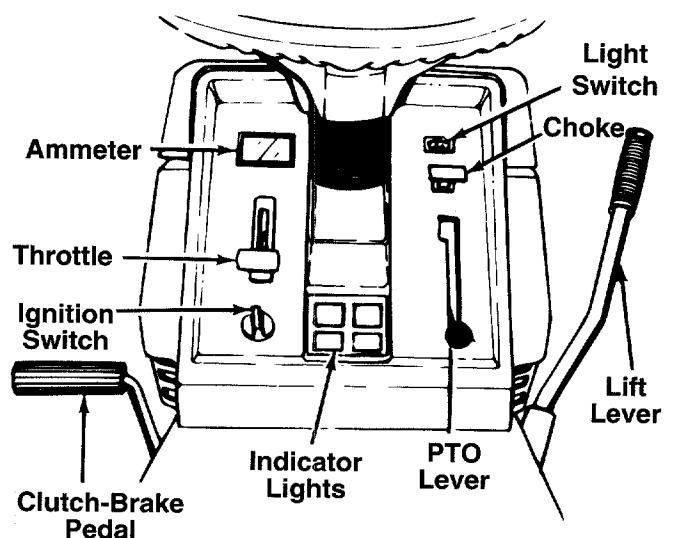

FIGURE 11.

CHOKE CONTROL

The choke control is located on the right side of the dashboard and is operated manually. Details for the choke operation are covered in the separate engine manual packed with your unit. See figure 11.

LIGHT SWITCH

The head lamps are operated by pushing the light switch located on the dashboard. The head lamps will only operate when the engine is running. See figure 11.

AMMETER

The ammeter registers the rate of battery charge or discharge. The ammeter will register on the discharging side when starting the engine. It should register on the opposite side (charging) when the engine is running in the fast position until the battery is completely charged. With a fully charged battery or with the engine idling, the ammeter will not show a charge. See figure 11.

HYDROSTATIC CONTROL LEVER

The hydrostatic control lever is located on top of the fender on the left side of the tractor. This single control lever, connected to the hydrostatic transmission, controls both the speed and direction of the tractor. Infinite speed control is achieved by moving the control lever forward or backward. The farther forward or backward you move the control lever, the faster you will travel. Pulling the control lever into neutral (N) area will stop the tractor. To increase rear wheel torque (pulling power), move the control lever towards neutral (N) position. The lawn tractor responds similar to shifting to a lower gear with a gear type transmission. See figure 12.

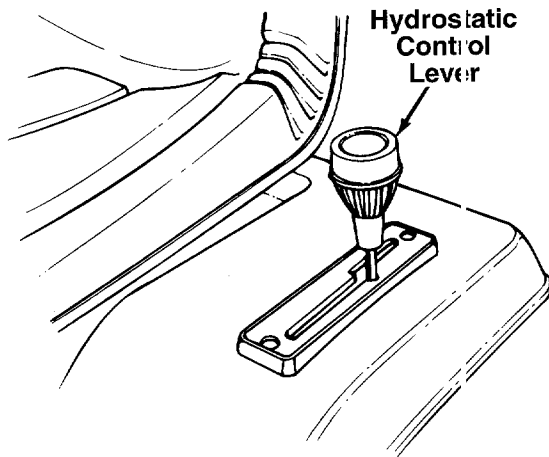

FIGURE 12.

CLUTCH-BRAKE PEDAL

The clutch-brake pedal is located on the left side of the tractor. See figure 11. Depressing the pedal disengages the engine from the hydrostatic transmission and applies the brake.

NOTE: The clutch-brake pedal must be depressed to start the engine.

PARKING BRAKE

To set the parking brake, depress the clutch-brake pedal and pull up the parking brake knob. It will stay in the raised position. To release the parking brake, depress and release the clutch-brake pedal. See figure 13.

NOTE: The parking brake must be set if the operator leaves the seat with the engine running.

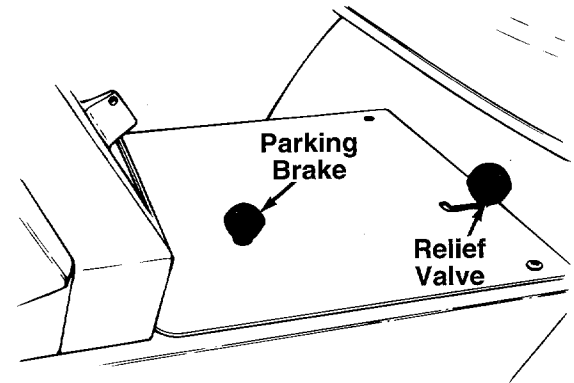

FIGURE 13.

RELIEF VALVE

A hydrostatic relief valve is provided so the unit can be moved without the engine running. The lever which operates the relief valve is located on the console. See figure 13.

To operate the relief valve, place the hydrostatic control lever in neutral, release the parking brake, push the lever forward and to the right to lock. Be certain to release the lever by pushing it to the left before operating the engine.

LIFT LEVER

The five position lift lever is used to change the operating position of the attachments. To operate, pull the lever towards you. To release, move the lever to the right and then forward. See figure 11.

POWER TAKE-OFF (PTO) LEVER

The PTO lever is located on the right side of the dashboard. The PTO lever is used to engage and disengage the power to the attachments. To engage the PTO, lift the lever slowly and lock it into the notch. See figure 11.

NOTE: The PTO lever **must** be in the disengaged position (down) when starting the engine, when shifting into reverse and if the operator leaves the seat.

INDICATOR LIGHTS

The unit is equipped with three indicator lights, located on the dash panel. See figure 11. If a light illuminates when attempting to start the unit, proceed as follows:

CLUTCH—Depress the clutch pedal.

PTO—Disengage the PTO.

OIL—Check the crankcase oil level, and add oil as required.

OPERATION



WARNING

AVOID SERIOUS INJURY OR DEATH

- GO UP AND DOWN SLOPES, NOT ACROSS. • AVOID SUDDEN TURNS.
- DO NOT OPERATE THE UNIT WHERE IT COULD SLIP OR TIP.
- IF MACHINE STOPS GOING UPHILL, STOP BLADE(S) AND BACK DOWNHILL SLOWLY.
- DO NOT MOW WHEN CHILDREN OR OTHERS ARE AROUND.
- NEVER CARRY CHILDREN.
- LOOK DOWN AND BEHIND BEFORE AND WHILE BACKING.
- KEEP SAFETY DEVICES (GUARDS, SHIELDS, AND SWITCHES) IN PLACE AND WORKING.
- REMOVE OBJECTS THAT COULD BE THROWN BY THE BLADE(S).
- KNOW LOCATION AND FUNCTION OF ALL CONTROLS.
- BE SURE BLADE(S) AND ENGINE ARE STOPPED BEFORE PLACING HANDS OR FEET NEAR BLADE(S).
- BEFORE LEAVING OPERATOR'S POSITION, DISENGAGE BLADE(S), PLACE THE SHIFT LEVER IN NEUTRAL, ENGAGE BRAKE LOCK, SHUT ENGINE OFF AND REMOVE KEY.

READ OPERATOR'S MANUAL

GAS AND OIL FILL-UP

Check oil level and add if necessary. Service the engine with gasoline as instructed in the separate engine manual packed with your tractor. Read instructions carefully.

IMPORTANT: Your tractor is shipped with oil; however, you **must** check the oil level before operating. Be careful not to overfill.

The gasoline tank is located under the seat. The filler neck is behind the seat. Do not overfill.



WARNING: Never fill fuel tank indoors, with engine running or while engine is hot.

OPERATING THE TRACTOR

IMPORTANT: This unit is equipped with a **safety interlock system** for your protection. The purpose of the safety interlock system is to prevent the engine from cranking or starting unless the clutch-brake pedal is depressed and the PTO lever is in the disengaged position. In addition, the PTO lever must be in the disengaged position when the unit is put into reverse or the engine will shut off. If the operator leaves the seat with the PTO lever engaged and/or without setting the parking brake, the engine will shut off.



WARNING: Do not operate the tractor if the interlock system is malfunctioning because it is a safety device, designed for protection.

1. Place the PTO lever in the disengaged (down) position.
2. Depress the clutch-brake pedal and set the parking brake.

3. Place the hydrostatic control lever in the NEUTRAL (N) position.
4. Set the throttle control in the FAST position.
5. Pull out the choke control. (A warm engine requires less choking.)
6. Turn the ignition key to the right to the START position. After the engine starts, release the key. It will return to the ON position.
7. Slowly push in the choke as the engine warms up.
8. Depress the clutch-brake pedal so the parking brake is released and then release the clutch-brake pedal.
9. Move the hydrostatic control lever forward. The farther forward you move the hydrostatic control lever, the faster you will travel.
10. To stop the tractor, pull the hydrostatic control lever into NEUTRAL (N) or depress the clutch-brake pedal.
11. To shut off the engine, turn the ignition key to the left to the OFF position. Remove the key to prevent accidental starting while equipment is unattended.

Be sure that the lawn is clear of stones, sticks, wire, or other objects which could damage lawn tractor or engine. For best results and to insure more even grass distribution, do not mow when lawn is excessively wet.



WARNING: Before leaving the operator's position for any reason, disengage the blades, place the shift lever in neutral, engage the parking brake, shut engine off and remove the key.

When stopping the unit to empty a grass bag, etc., follow the instructions above. This procedure will also eliminate "browning" the grass, which is caused by hot exhaust gases from a running engine.

IMPORTANT: If you strike a foreign object, stop the engine. Remove wire from spark plug, thoroughly inspect the mower for any damage, and repair the damage before restarting and operating the mower.

NOTE: If any problems are encountered, refer to the *Trouble Shooting Guide* on page 17.

GRASS COLLECTOR Model 190-083 is available as optional equipment for the lawn tractor shown in this manual.



WARNING: The mower should not be operated without the entire grass catcher or chute deflector in place.

NOTE: Under normal usage bag material is subject to wear, and should be checked periodically. Be sure any replacement bag complies with the mower manufacturer's recommendations.

For replacement bags, use only factory authorized replacement bag.

ADJUSTMENTS



WARNING: Disconnect the spark plug wires and ground against the engine before performing any adjustments, repairs or maintenance.

SEAT ADJUSTMENT

To adjust the position of the seat, loosen the four self-tapping screws on the bottom of the seat. See figure 1. Slide the seat forward or backward as desired. Retighten the self-tapping screws.

HYDROSTATIC NEUTRAL CONTROL ADJUSTMENT

The hydrostatic transmission control is in correct adjustment when the tractor does not move with the engine running, the clutch engaged and the hydrostatic control lever in the neutral position.

If adjustment is necessary, follow these steps:

1. Raise both rear wheels off the ground by placing blocks under the rear frame.
2. Remove the transmission panel by removing the parking brake knob and truss machine screws.
3. Loosen the hex jam nut on the speed selector adjusting rod. See figure 14.

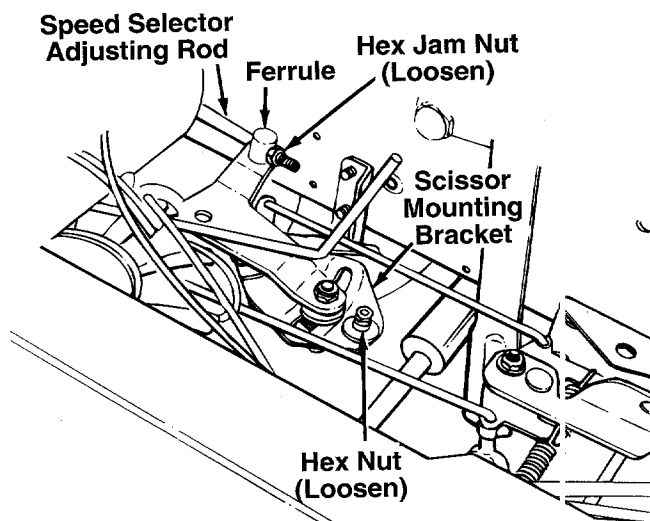

FIGURE 14.

4. Loosen the hex nut on the scissor mounting bracket. See figure 14.
5. Start the engine and run at full throttle.
6. Move the hydrostatic control lever until you find neutral (rear wheels do not rotate in either direction).



WARNING: Be careful of the cooling fan on the hydrostatic transmission.

7. Depress the clutch-brake pedal all the way and set the parking brake.
8. Shut off the engine.
9. Tighten the hex nut on the scissor mounting bracket.
10. Thread the speed selector rod in or out of the ferrule until the hydrostatic control lever lines up in the neutral position on the speed control index bracket.
11. Tighten hex jam nut against the ferrule.
12. Replace the transmission panel and parking brake knob.
13. Remove the blocks from under the frame and test the operation of the tractor.

LEVELING THE DECK

1. Check tire pressure in all four tires. Recommended pressure is approximately 12 p.s.i.
2. Make certain all deck wheels are mounted in same relative location.
3. On a level surface, engage the PTO and lower the deck until it reaches the ground.

All four deck wheels should reach the ground at the same time. If they do not, adjust the deck links as necessary.

NOTE: When adjusting the deck links, disengage the PTO. Remove the hairpin clip and washer from the weld bolt. Thread eyebolt up or down the link as necessary, and reassemble.

4. Raise the deck 1/2" to 1" above the ground.

Check to be certain the distance from the bottom edge of the deck to the ground is the same on both sides of the deck. If it is not, adjust the links on the left side of the unit.

Check to be certain the front of the deck is 1/4" to 3/8" lower than the rear of the deck. If it is not, adjust the two front links to obtain this distance.

STEERING WHEEL ADJUSTMENT

There are four height positions for the steering wheel. To adjust the height of the steering wheel, remove the hex bolt and hex lock nut on the steering shaft. Place the steering wheel in the position desired and secure with hex bolt and hex lock nut. Refer to figure 4.

NOTE: When raising the height of the steering wheel, stretch the steering bellows to cover the steering shaft.

The steering shaft may also be adjusted if there is too much play between the steering gear and segment.

To adjust, loosen the hex bolt and nut on the front of the bearing retainer bracket. See figure 15. Pry the bearing retainer bracket toward the right until the steering gear engages solidly into the teeth of the steering segment. Retighten the hex bolt and nut.

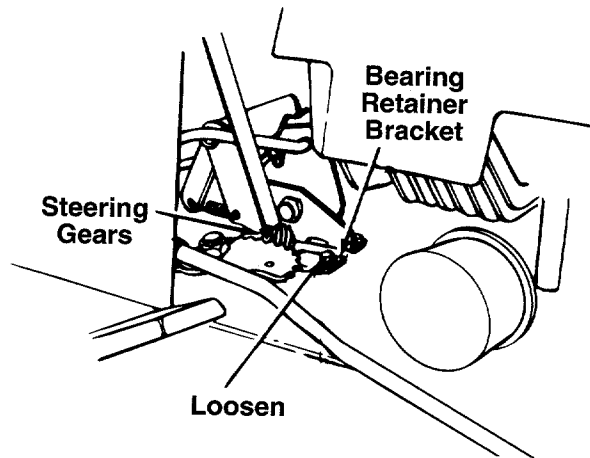

FIGURE 15.

BRAKE ADJUSTMENT (See figure 16)

The brake is located by the right rear wheel inside the frame. During normal operation of this machine, the brakes are subject to wear and will require periodic examination and adjustment.

WARNING: Do not adjust the brake while the engine is running. Be sure to block the wheels of the tractor before making the brake adjustment.

To adjust the brake, remove the cotter pin. Adjust the castle nut so the brake starts to engage when the brake lever is 1/4" to 5/16" away from the axle housing.

NOTE: Figure 16 is shown with the unit tipped up on rear wheels for clarity only.

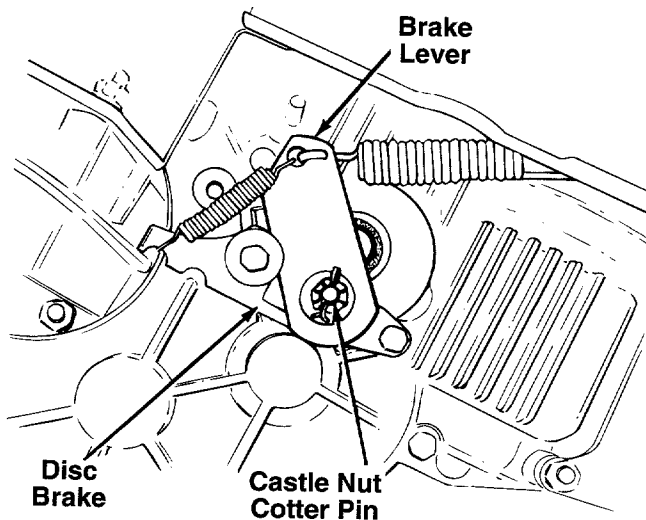

FIGURE 16.

CARBURETOR ADJUSTMENTS



WARNING: If any adjustments are made to the engine while the engine is running (e.g. carburetor), disengage all clutches and blades. Keep clear of all moving parts. Be careful of heated surfaces and muffler.

Minor carburetor adjustments may be required to compensate for differences in fuel, temperature, altitude and load. Refer to separate engine manual for carburetor adjustment information.

NOTE: A dirty air cleaner will cause an engine to run rough. Be certain air cleaner is clean and attached to the carburetor before adjusting carburetor.

LUBRICATION



WARNING: Always stop engine and disconnect spark plug wires before cleaning, lubricating or doing any kind of work on lawn tractor.

STEERING GEARS

Lubricate teeth of steering gears with automotive multi-purpose grease after every 25 hours of operation or once a season. Refer to figure 15.

STEERING SHAFT

Lubricate steering shaft at least once a season with light oil.

TRANSAXLE

The transaxle is lubricated at the factory and does not require checking. If repairs are needed contact your local service dealer.

LINKAGE

Once a season lubricate all the pivot points on the clutch, brake and lift linkage with SAE 30 engine oil.

FRONT WHEELS

The front wheels are provided with grease fittings. The rear wheels must be removed from the axle for lubrication. Lubricate at least once a season with automotive multi-purpose grease.

PIVOT POINTS

Lubricate all pivot points with light oil at least once a season.

BALL JOINTS

The ball joints and drag link ends are permanently lubricated.

MAINTENANCE



WARNING: Disconnect the spark plug wire and ground against the engine before performing any adjustments, repairs or maintenance.

TROUBLE SHOOTING

Refer to the chart on page 17 for trouble shooting engine problems.

HYDROSTATIC TRANSMISSION COOLING

The hydrostatic transmission is cooled by the oil, fan and fins. If the hydrostatic transmission runs hot, check to see if the fan is in operating condition and the fins are clean.

NOTE: DO NOT use high pressure water spray or steam to clean the hydrostatic transmission.

ENGINE

Refer to the separate engine manual for all engine maintenance instructions.

Service **air cleaner** every 10 hours under normal conditions. Clean every few hours under extremely dusty conditions. To service the air cleaner, refer to the separate engine manual packed with your unit.

The **spark plugs** should be cleaned and the gap reset once a season. Spark plug replacement is recommended at the start of each mowing season; check engine manual for correct plug type and gap specifications.

Maintain **engine oil** as instructed in the separate engine manual packed with your unit. **Read and follow instructions carefully.**

FUEL FILTER

Your unit is equipped with a replaceable in-line fuel filter. Replace filter whenever contamination or discoloration is noticed. Order replacement filter through your authorized engine service dealer.

CLEANING ENGINE AND DECK

Any fuel or oil spilled on the tractor should be wiped off promptly. Grass, leaves and other dirt must not be left to accumulate around the cooling fins of the engine or on any part of the machine.

Clean the underside of the deck after each mowing.

WHEEL ADJUSTMENT

The caster (forward slant of the king pin) and the camber (tilt of the wheels out at the top) require no adjustment. Automotive steering principles have been used to determine the caster and camber on the tractor. The front wheels should toe-in 1/8 inch.

To adjust the toe-in, follow these steps.

1. Remove the hex nut and lock washer, and drop the end of the tie rod from the axle bracket. See figure 17.
2. Loosen the hex jam nut on tie rod.
3. Adjust the tie rod assembly for correct toe-in.

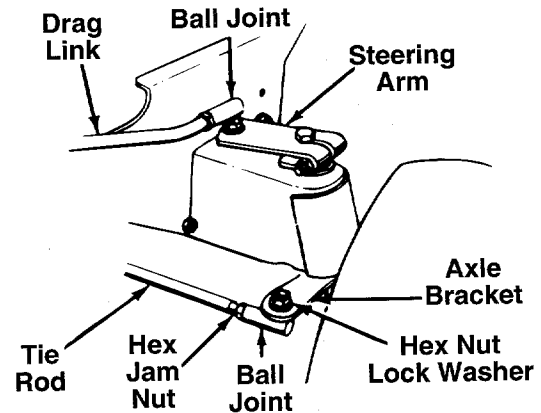

FIGURE 17.

Dimension "B" should be approximately 1/8" less than Dimension "A." See figure 18. To increase Dimension "B," screw tie rod into tie rod end. To decrease Dimension "B," unscrew tie rod from tie rod end. Reassemble tie rod. Check dimensions. Readjust if necessary.

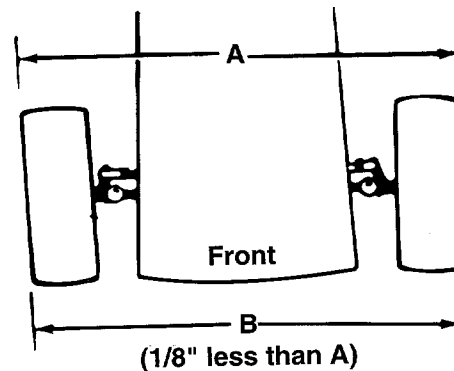

FIGURE 18.

DRAG LINK

If the drag link or ball joints are changed, the new assembly must be adjusted to the exact same length as the original. If adjusted incorrectly, it will allow the tractor to turn sharper one direction than the other.

To take off the drag link, remove the nuts and lock washers holding the ball joint to the steering gear and right front axle bracket. See figure 17.

BATTERY CARE AND MAINTENANCE

CHECK FLUID LEVEL

Check fluid level inside each cell of the battery every two weeks and before and after charging. Always keep level between the LOWER LEVEL and UPPER LEVEL lines on battery.

Add only distilled water. Never add additional acid or any other chemicals to the battery after initial activation.

NOTE: After operating the lawn tractor for a long period of time, check the fluid level in the battery as it can overheat and lose fluid.

CHARGING THE BATTERY

The engine is equipped with an alternator which charges battery when tractor is operated. Under normal conditions, the battery only needs to be charged before, during and after off-season storage. Follow the instructions under "Off-Season Storage."

To charge the battery: Make certain fluid level in each cell is between LOWER LEVEL and UPPER LEVEL. Use a 12 volt automotive charger which is rated less than 10 amps. Charge for a minimum of 3 hours and a maximum of 5 hours.

REMOVING / INSTALLING / JUMP STARTING



WARNING: When removing or installing the battery, follow these instructions to prevent the screwdriver from shorting against the frame.

Removing the Battery: Disconnect negative cable first, then positive cable.

Installing the Battery: Connect positive cable first, then negative cable.

Jump Starting

1. First, connect end of one jumper cable to the positive terminal of the good battery, then the other end to the positive terminal of the dead battery.
2. Connect the other jumper cable to the negative terminal of the good battery, then to the FRAME OF THE UNIT WITH THE DEAD BATTERY.



WARNING: Failure to use this procedure could cause sparking, and the gas in either battery could explode.

CLEAN THE BATTERY

Clean the battery by removing it from the unit and washing with a baking soda and water solution. If necessary, scrape the battery terminals with a wire brush to remove deposits. Coat terminals and exposed wiring with grease or petroleum jelly to prevent corrosion.

BATTERY FAILURES

Some common causes for battery failure are: incorrect initial activation, lack of water, adding chemicals other than water after initial activation, undercharging, overcharging, corroded connections, freezing. **These failures do not constitute warranty.**

TIRES

Recommended operating tire pressure is approximately 12 p.s.i. (check sidewall of tire for tire manufacturer's recommended pressure). Maximum tire pressure under any circumstances is 30 p.s.i. Equal tire pressure should be maintained on all tires.

When installing a tire to the rim, be certain rim is clean and free of rust. Lubricate both the tire and rim generously. Never inflate to over 30 p.s.i. to seat beads.



WARNING: Excessive pressure (over 30 p.s.i.) when seating beads may cause tire/rim assembly to burst with force sufficient to cause serious injury.

DRIVE BELT REPLACEMENT (See figure 19)

1. Depress the clutch pedal and set parking brake.
2. Remove the deck from the tractor.
3. Raise and block the front wheels of the tractor so you can work under it.
4. Remove the four self-tapping screws which hold the belt keeper assembly to the frame at the engine pulley. Push the belt keeper assembly forward, out of the way. See figure 19.
5. Loosen the hex bolt which acts as a belt keeper by the front idler pulley.
6. Loosen the rear idler pulley. Remove the belt from around both idler pulleys.
7. Roll belt up off engine pulley, onto the pulley hub to obtain slack in the belt.
8. Remove belt from the transmission pulley, lifting the belt up over the fan on top of the pulley.
9. Remove belt from the engine pulley.

Reassemble using a new belt, following instructions in reverse order.

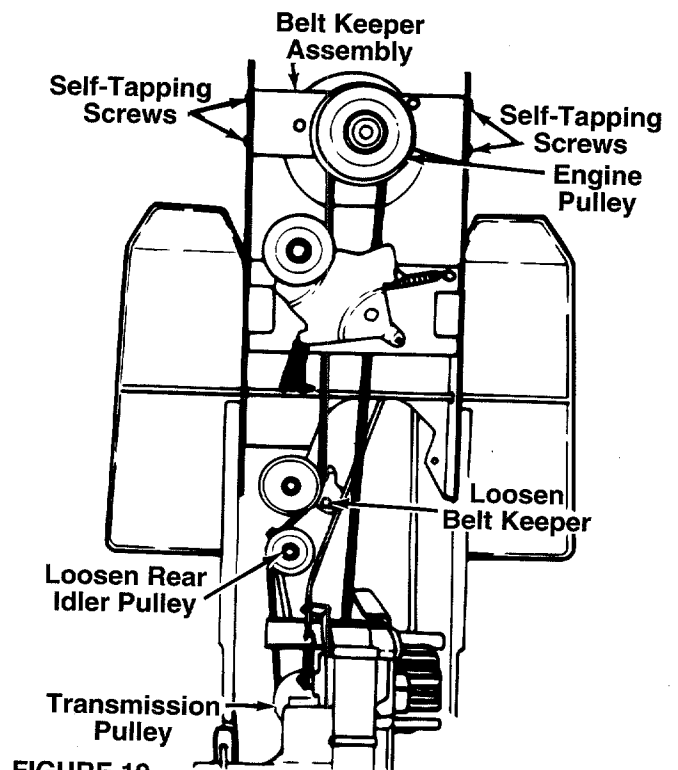

FIGURE 19.

OFF-SEASON STORAGE

If the machine is to be inoperative for a period longer than 30 days, prepare for storage as follows.

1. Clean the engine and the entire unit thoroughly.
2. Lubricate all lubrication points. Wipe the entire machine with an oiled rag to protect the surfaces.
3. Refer to the engine manual for correct engine storage instructions. The engine must be completely drained of fuel to prevent gum deposits from forming on essential carburetor parts, fuel lines and fuel tanks.

4. **Charge battery fully.** The battery loses some of its charge each day when the unit is not used. NEVER store battery without a full charge. Recharge battery before returning to service or every two months, whichever occurs first.

5. Store unit in a clean, dry area. Do not store next to corrosive materials, such as fertilizer.

NOTE: *When storing any type of power equipment in an unventilated or metal storage shed, care should be taken to rustproof the equipment. Using a light oil or silicone, coat the equipment, especially any chains, springs, bearings and cables.*

OPTIONAL EQUIPMENT

At the time of manufacture of tractor, the following optional equipment is available.

| Description | Model No. |
|------------------------------------|-------------|
| 40" Single Stage Snow Thrower | 190-832-000 |
| 45" Two Stage Snow Thrower | 190-831-000 |
| 48" Dozer Blade | 190-840-000 |
| Grass Collector for 46" Deck Only | 190-083-000 |
| Tire Chains—23 x 9.5 | 190-964-000 |
| 100 lb. Wheel Weights | 190-784-000 |
| Sleeve Hitch Kit | 190-929-000 |
| Electric Lift Kit | 190-749-000 |
| Row Crop Cultivator | 190-984-000 |
| 28" PTO Driven Rear Mounted Tiller | 190-756-000 |
| 38" 8 HP Rear Mounted Tiller | 190-766-000 |
| Single Disc Harrow | 190-980-000 |
| 10" Moldboard Flow | 190-978-000 |
| Gang Reel (Set of three) | 45-0195* |
| 38" Lawn Sweeper | 45-0222* |
| Heavy Duty Lawn Roller | 45-0179* |
| Heavy Duty Dump Cart | 45-0171* |
| Tine De-Thatcher | 45-0186* |

*Available through your local dealer or from Agri-Fab Inc., 303 W. Raymond Street, Sullivan, Illinois 61951.

TROUBLE SHOOTING GUIDE

| PROBLEM | POSSIBLE CAUSE(S) | CORRECTIVE ACTION |
|---|---|--|
| Engine will not crank | Battery installed incorrectly | The battery must be installed with negative terminal attached to black ground wire. Negative terminal is identified at the post by "NEG", "N" or "-". The positive terminal, identified by "POS", "P" or "+", must be attached to the big red wire which goes to the solenoid. |
| | Battery is dead or weak | Check fluid level in battery. If fluid is low, fill to UPPER LEVEL line with water. Charge with taper charger until fully charged. |
| | Blown fuse or circuit breaker | Replace fuse with 7-1/2 amp. automotive type fuse. Fuses seldom fail without a reason. The problem must be corrected. Check for loose connections in the fuse holder. Replace fuse holder if necessary. A dead short may be in the cranking or charging circuit where the insulation may have rubbed through and exposed the bare wire. Replace the wire or repair with electrician's tape if the wire strands have not been damaged. Note: Look for a wire pinched between body panels, burned by the exhaust pipe or muffler or rubbed against a moving part. |
| | Engine ground wire loose | Engine should have a black ground wire running from engine to frame or mounting bolt. |
| | Safety switch button not depressed | There are two switches in the starting circuit of your unit: the clutch pedal switch and the deck lift lever switch. Make certain the actuator is fully depressing the buttons on each switch. |
| Engine cranks but will not start | Throttle or choke not in starting position | Check owner's guide for correct position for throttle control and choke for starting. |
| | No spark to spark plug | Spark plug lead disconnected. Connect lead. Hold spark plug lead away from engine block about 1/8". Crank engine. There should be a spark. If not, have engine repaired at authorized engine service dealer. Faulty spark plug. To test, remove spark plug. Attach spark plug lead to spark plug. Ground the spark plug body against the engine block. Crank the engine. The spark plug should fire at the electrode. Replace if it does not. |
| | No fuel to the carburetor | Gasoline tank empty. Fill. Fuel line or in-line fuel filter plugged. Remove and clean fuel line. Replace filter if necessary. |
| | Air filter dirty | If the air cleaner is dirty, the engine may not start. Clean or replace as recommended by the engine manufacturer. |
| Engine smokes | Engine loses crankcase vacuum | Dipstick not seated or broken. Replace defective part. Engine breather defective. Replace. |
| Excessive vibration | Bent or damaged blade spindle | Stop engine immediately. Check all pulleys, blade adapters, keys and bolts for tightness and damage. Tighten or replace any damaged parts. |
| | Bent blade | Stop engine immediately. Replace damaged blade. Only use original equipment blades. |
| Mower will not discharge grass or leaves uncut strips | Engine speed low Speed selection Blades short or dull | Throttle must be set at full throttle. Use lower ground speed. The slower your ground speed, the better the quality of cut. Sharpen or replace blades (uncut strip problem only). |

If the above steps fail to correct the problem, take the unit to your local authorized service dealer for repair.



TWO YEAR LIMITED WARRANTY

For TWO YEARS from the date of retail purchase within the United States of America, its possessions and territories, YARD-MAN will, at its option, repair or replace, for the original purchaser, free of charge, any part or parts found to be defective in material or workmanship. This warranty covers units which have been operated and maintained in accordance with the owner's instructions furnished with the unit, and which have not been subject to misuse, abuse, commercial use, neglect, accident, improper maintenance or alteration.

Normal wear parts or components thereof are subject to separate terms as noted below in the "No Fault Ninety Day Consumer Warranty" clause.

Two year consumer warranty on normal wear parts with ninety day no fault protection. All normal wear part failures will be covered on this product for a period of 90 days regardless of cause. After 90 days but within the two year warranty period, normal wear parts failures will be covered if caused by defects in material or workmanship or other component parts. Normal wear parts are defined as batteries, belts, blades, blade adapters, grass bags, rider deck wheels, and seats.

How to obtain service: Warranty service is available, with proof of purchase, through your local authorized service dealer. To locate the dealer in your area, please check the yellow pages or contact the Customer Service Department of YARD-MAN, P.O. Box 361131, Cleveland, Ohio 44136-0019. Phone 1 (800) YARD-MAN. The return of a complete unit will not be accepted by the factory unless prior written permission has been extended by the service department of YARD-MAN.

Transportation charges: Transportation charges for the movement of any power equipment unit or attachment are the responsibility of the purchaser.

Units exported out of the United States: YARD-MAN does not extend any warranty for products sold or exported outside of the United States of America, its possessions and territories, except those sold through YARD-MAN'S authorized channels of export distribution.

OTHER WARRANTIES:

1. The engine or component parts thereof carry separate warranties from their manufacturers. Please refer to the applicable manufacturer's warranty on these items.
2. Log splitter pumps, valves and cylinders or component parts thereof are covered by a one year warranty.
3. All other warranties, express or implied, including any implied warranty of merchantability or fitness for a particular purpose, are hereby expressly disclaimed in their entirety.
4. The provisions as set forth in this warranty provide the sole and exclusive remedy of YARD-MAN'S obligations arising from the sales of its products. YARD-MAN will not be liable for incidental or consequential loss or damage.

How state law relates to this warranty: This limited warranty gives you specific legal rights, and you may also have other rights which vary from state to state. Certain disclaimers are not allowed in some states and therefore they may not apply to you under all circumstances.

NOTE: This warranty does not cover routine maintenance items such as lubricants, filters, blade sharpening and tune-ups, or adjustments such as brake adjustments, clutch adjustments or deck adjustments. Nor does this warranty cover normal deterioration of the exterior finish due to use or exposure.

**Copy the information from
your model plate here:**

**Please help us
help you!**

**Have your
model number
available
when you call**

| Model No. | V834H | W834P |
|-------------------------------|--------------|--------------|
| Engine Oil (SAE 30) | 737-0208 | 737-0208 |
| Ignition Key | 725-1341B | 725-1341B |
| Throttle Control Wire | 746-0634 | 746-0630 |
| Battery (275 Cold Crank Amps) | 725-1635 | 725-1635 |
| Steering Wheel | 731-0806A | 731-0806A |
| Steering Wheel Insert | 731-0955 | 731-0955 |
| Front Wheel Bearing | 741-0516 (4) | 741-0516 (4) |
| Hub Cap Front | 634-0084 | 634-0084 |
| Hub Cap Rear | 634-0086 | 634-0086 |
| Head Lamp Bulbs | 725-0963 (2) | 725-0963 (2) |
| Drive Belt | 754-0435 | 754-0435 |
| Upper Deck Belt | 754-0350 | 754-0291A |
| Lower Deck Belt | 754-0349 | 754-0364 |
| Outer Blades | 742-0542 | 742-0171B |
| Center Blade | 742-0543 | 742-0171B |

For Optional Equipment Available, Refer to Page 16.

For Parts, Accessories or Service Information,

CALL NOW!

1 (800) 800-7310

9:00 AM to Midnight Monday through Friday

9:00 AM to 8:00 PM Saturday

Eastern Time (winter hours may vary)

VISA

MC

DISC

The only way to insure the performance of your product is to use original equipment parts and accessories, which are designed and engineered to exacting specifications. When you substitute, you take a chance on quality, reliability, safety and performance. Use original equipment parts—See your local service dealer.