

OWNER'S MANUAL

- ASSEMBLY
- OPERATION
- MAINTENANCE
- PARTS LIST

Model Nos.
13875A-8
13885A-8

Important:

Read Safety Rules and
Instructions Carefully

YARD-MAN

**36"
RIDING
MOWERS**

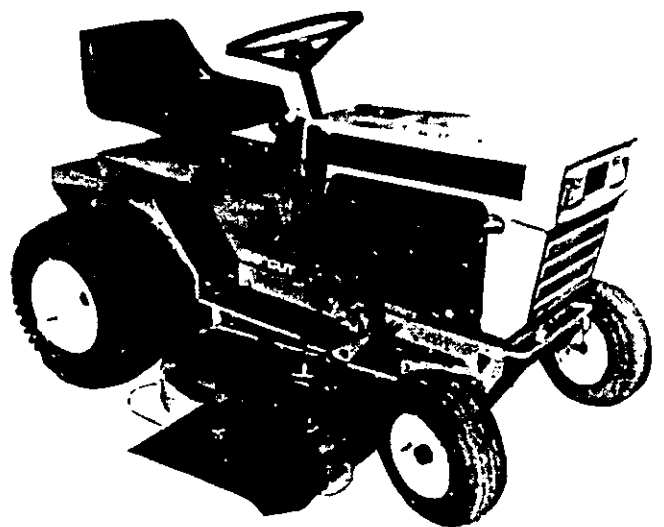

(MODEL 13885A-8 SHOWN)

LIMITED WARRANTY

For one year from the date of original retail purchase, YARD-MAN COMPANY will either repair or replace, at its option, free of charge, F.O.B. factory or authorized service firm, any part or parts found to be defective in material or workmanship. Transportation charges under this warranty must be paid by the purchaser unless return is requested by YARD-MAN COMPANY.

This warranty will not apply to any part which has become inoperative due to misuse, excessive use, accident, neglect, improper maintenance, alterations, or unless the unit has been operated and maintained in accordance with the instructions furnished. This warranty does not apply to the engine, motor, battery, battery charger or component parts thereof. Please refer to the applicable manufacturer's warranty on these items.

This warranty will not apply where the unit has been used commercially.

Warranty service is available through your local authorized service dealer or distributor. If you do not know the dealer or distributor in your area, please write to the Customer Service Department of YARD-MAN.

The return of a complete unit will not be accepted by the factory unless prior written permission has been extended by YARD-MAN.

This warranty gives you specific legal rights. You may also have other rights which vary from state to state.

WARNING TO PURCHASERS OF INTERNAL COMBUSTION ENGINE EQUIPPED MACHINERY OR DEVICES IN THE STATE OF CALIFORNIA

The equipment which you have just purchased does not have a spark arrester. If this equipment is used on any forest covered land, brush covered land, or grass covered unimproved land in the State of California, before using on such land, the California law requires that a spark arrester be provided. In addition, spark arrester is required by law to be in effective working order. The spark arrester must be attached to the exhaust system and comply with Section 4442 of the California Public Resources Code.

IMPORTANT

It is suggested that this manual be read in its entirety before attempting to assemble or operate. Keep this manual in a safe place for future reference and for ordering replacement parts.

This unit is shipped WITHOUT GASOLINE or OIL. After assembly, see operating section of this manual for proper fuel and amount.

Your rotary mower is a precision piece of power equipment, not a plaything. Therefore exercise extreme caution at all times.

SAFE OPERATION PRACTICES FOR RIDING VEHICLES

1. Know the controls and how to stop quickly—**READ THE OWNER'S MANUAL.**
2. Do not allow children to operate vehicle. Do not allow adults to operate it without proper instruction. Only persons well acquainted with these rules of safe operation should be allowed to use your mower.
3. Do not carry passengers.
4. Keep the area of operation clear of all persons, particularly small children and pets. Stop engine when they are in the vicinity of your mower. Although the area of operation should be completely cleared of foreign objects, a small object may have been overlooked and could be accidentally thrown by the mower in any direction.
5. Clear work area of objects which might be picked up and thrown by the mower in any direction.
6. Disengage all attachment clutches and shift into neutral before attempting to start engine.
7. Disengage power to attachment(s) and stop engine before leaving operator position.
8. Disengage power to attachment(s) and stop engine before making any repairs or adjustments. Disconnect the spark plug wire and keep the wire away from the plug to prevent accidental starting.
9. Before attempting to unclog the mower or discharge chute, stop the engine and be sure the blade(s) have stopped completely. Disconnect the spark plug wire and keep the wire away from the plug to prevent accidental starting.
10. Disengage power to attachment(s) when transporting or not in use.
11. Take all possible precautions when leaving vehicle unattended such as disengaging power-take-off, lowering attachments, shifting into neutral, setting parking brake, stopping engine and removing key.
12. Do not stop or start suddenly when going uphill or downhill. Mow up and down face of steep slopes; never across the face.
13. Reduce speed on slopes and in sharp turns to prevent tipping or loss of control. Exercise extreme caution when changing direction on slopes.
14. Stay alert for holes in terrain and other hidden hazards.
15. Use care when pulling loads or using heavy equipment.
 - A. Use only approved drawbar hitch points.
 - B. Limit loads to those you can safely control.
 - C. Do not turn sharply. Use care when backing.
- D. Use counterweight(s) or wheel weights when suggested in owner's manual.
16. Watch out for traffic when crossing or near roadways..
17. When using any attachments never direct discharge of material toward bystanders nor allow anyone near vehicle while in operation.
18. Handle gasoline with care—it is highly flammable.
 - A. Use approved gasoline container.
 - B. Never remove cap or add gasoline to a running or hot engine or fill fuel tank indoors. Wipe up spilled gasoline.
 - C. Open doors if engine is run in garage—exhaust fumes are dangerous. Do not run engine indoors.
19. Keep the vehicle and attachments in good operating condition, and keep safety devices in place. Use guards as instructed in owner's manual.
20. Keep all nuts, bolts, and screws tight to be sure the equipment is in safe working condition.
21. Never store the equipment with gasoline in the tank inside a building where fumes may reach an open flame or spark. Allow engine to cool before storing in any enclosure.
22. To reduce fire hazard keep engine free of grass, leaves or excessive grease.
23. The vehicle and attachments should be stopped and inspected for damage after striking a foreign object, and the damage should be repaired before restarting and operating the equipment.
24. Do not change the engine governor settings or overspeed the engine.
25. When using the vehicle with mower, proceed as follows:
 - (1) Mow only in daylight or in good artificial light.
 - (2) Never make a cutting height adjustment while engine is running if operator must dismount to do so.
 - (3) Shut the engine off and wait until the blade comes to a complete stop before removing the grass catcher.
 - (4) Check blade mounting bolts for proper tightness at frequent intervals.
26. Check grass catcher bags frequently for wear or deterioration. For safety protection replace only with new bag meeting original equipment specifications.
27. Look behind to make sure the area is clear before placing the transmission in reverse and backing up.

INDEX

Limited Warranty	2
Safe Operation Practices	3
Index	4
Assembly	5
Battery Information	5
Before Starting Engine	7
Controls	8
Operation of Controls	9
Cutting Tips	11
Lubrication	12

Maintenance	12
Adjustments	13
Belt Removal	15
Illustrated Parts for Rider	20, 22, 24, 26
Parts Lists for Rider	21, 23, 25, 27
Illustrated Parts for Transaxle	28
Parts List for Transaxle	29
Electrical Diagram	30
Parts Information	Back Cover

GRASS CATCHER Model No. 19014-8 is available as optional equipment for the mowers shown in this manual.



WARNING

The mower should not be operated without the entire grass catcher or chute deflector in place.

NOTE

Under normal usage bag material is subject to wear, and should be checked periodically. Be sure any replacement bag complies with the mower manufacturer's recommendations.

For replacement bags, use only factory authorized replacement bag No. 764-0157

IMPORTANT

After striking a foreign object, stop the engine. Remove wire from spark plug, thoroughly inspect the mower for any damage, and repair the damage before restarting and operating the mower.

The steering wheel and seat, with the necessary hardware, are easily assembled to the machine. On the electric starter models, the battery must be activated and installed as outlined in this section.

TIRE PRESSURE

FOR SHIPPING PURPOSES, THE TIRES ON YOUR UNIT MAY BE OVER-INFLATED. TIRE PRESSURE SHOULD BE REDUCED BEFORE UNIT IS PUT INTO OPERATION. PRESSURE SHOULD BE APPROXIMATELY 15 P.S.I. EQUAL TIRE PRESSURE SHOULD BE MAINTAINED ON ALL TIRES. MAXIMUM TIRE PRESSURE IS 30 P.S.I.



CAUTION

Installation of tire to rim:

1. Lubricate tire beads and rim flanges.
2. Do not exceed 30 P.S.I. when seating beads.
3. Adjust to recommended pressure after beads are sealed.

NOTE

Reference to right-hand or left-hand side of machine is from the driver's seat facing forward.

List of Contents in Hardware Pack.

See figure 1.

- A (1) Spring Pin Spiral 1/4" Dia. x 1.00" Long
- B (1) Lockwasher 1/2" Screw
- C (1) Hex Nut 1/2-13 Thread

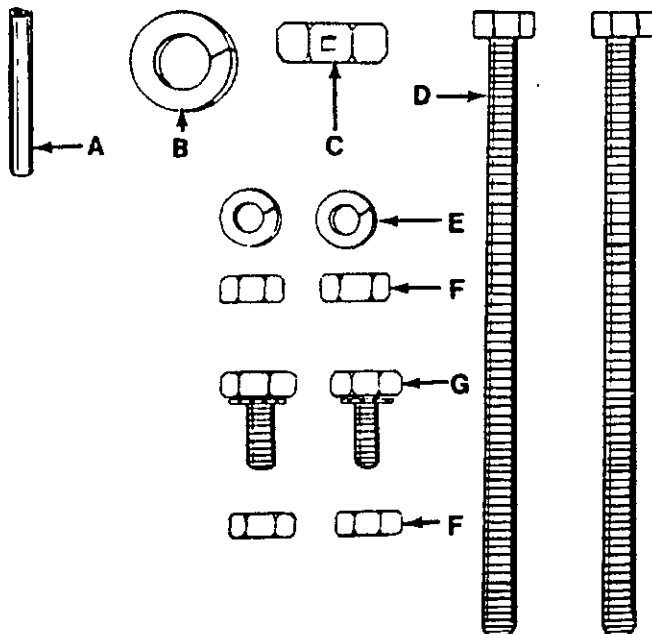

FIGURE 1. HARDWARE SUPPLIED

- D (2) Hex Screws 1/4-20 x 5.50" Long
- E (2) Lockwashers 1/4" Screw
- F (4) Hex Nuts 1/4-20 Thread
- G (2) Hex Sems Screws 1/4-20 x .62" Long

ASSEMBLY

STEERING WHEEL

First, place the steering shaft cover over the steering shaft. Then position the steering wheel on top of the steering shaft. You will note there is a hole in the steering wheel hub, in the steering shaft cover and in the steering shaft. Align these three holes and secure the three parts by driving a spring pin (A) through the three aligned holes. (Alignment can be simplified by inserting a punch or small rod through the three holes from the side opposite the spring pin insertion side.) See figure 2.

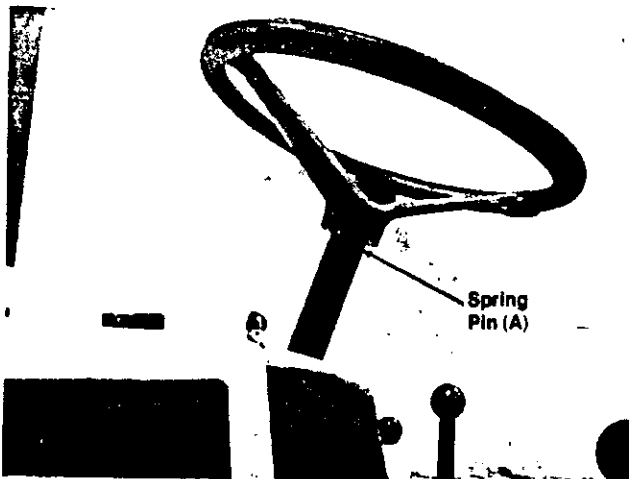

FIGURE 2. STEERING WHEEL ASSEMBLY

SEAT

Your molded seat comes with the mounting bolt molded in the seat.

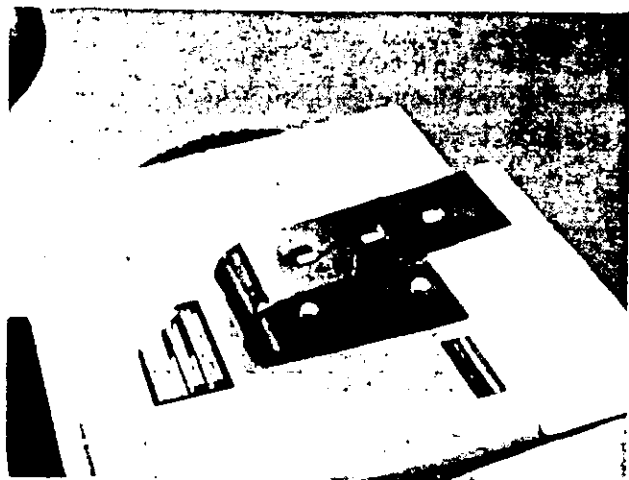

FIGURE 3. SEAT ASSEMBLY

The seat spring has three holes to provide a forward or backward adjustment of the seat. To check for the best seat position, sit in the seat and work the foot pedal. If adjustment is needed, unfasten the seat and replace it in a forward or backward hole. See figure 3.

Place seat on spring and secure with lockwasher (B) and hex nut (C). See figure 4.

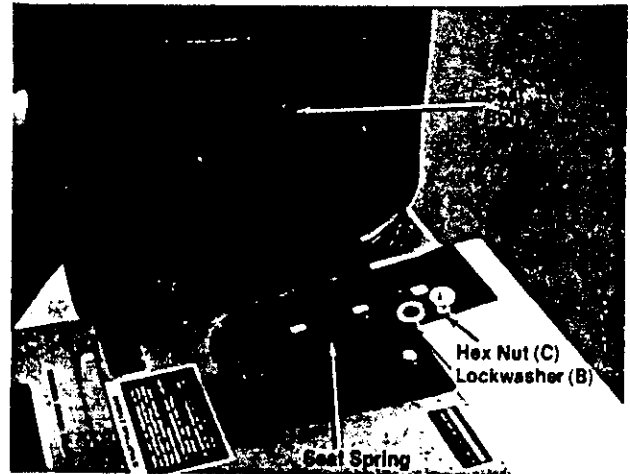

FIGURE 4. SEAT ASSEMBLY



NOTE

Check ALL nuts and bolts for correct tightness.

BATTERY INFORMATION FOR ELECTRIC START MODELS



WARNING

- A. Battery acid must be handled with great care as it will blister the skin and damage clothing. It is advisable to wear goggles, rubber gloves, and a protective apron when working with it.
- B. Neutralize acid spilled on clothing with dilute ammonia water or a water solution of baking soda. If acid gets on clothes, dilute it with clean water first, then neutralize.
- C. If for any reason acid should be spattered in the eyes, wash it out immediately with clean cold water. Seek medical aid if discomfort continues.
- D. Since battery acid is corrosive to metals, do not pour into any sink or drain. Rinse empty electrolyte containers and mutilate before discarding.



DANGER

BATTERIES CONTAIN SULFURIC ACID AND MAY CONTAIN EXPLOSIVE GASES (when electrolyte has been added)

- A. Keep sparks, flame, cigarettes away.
- B. Hydrogen gas is generated during charging and discharging.
- C. Ventilate when charging or using in enclosed space.
- D. When using a charger—to avoid sparks, NEVER connect or disconnect charger clips to battery while charger is turned on.
- E. Always shield eyes, protect skin and clothing when working near batteries.

ACTIVATING THE BATTERY

- 1. Place battery to be filled on bench or workbench. NEVER activate battery in unit. Remove vent caps from all cells.
- 2. Fill each cell carefully using battery grade 1.250-1.265 specific gravity. Sulfuric acid to be 3/8" above the top of the separators or to split ring.
- 3. Allow battery to set for 20 minutes to 1/2 hour. Add additional acid if necessary to bring it up to the proper level.
- 4. Replace the vent caps.
- 5. The battery can now be charged after the 20 minutes setting period. Battery can be SLOW CHARGED (DO NOT FAST CHARGE) at a maximum bench rate of 4-5 amperes until the specific gravity reading is 1.265-1.275. A charging rate in excess of this will buckle and warp the positive plates and perforate the separators. If electrolyte bubbles violently while charging, reduce charging rate until excessive bubbling action subsides, then continue charging until specific gravity is reached.



CAUTION

After battery has been in service, add only approved water. DO NOT ADD ACID.

B. TO INSTALL BATTERY

To install the battery in this unit, refer to page 7.

C. MAINTENANCE

- 1. Check periodically (every two weeks or before and after charging) to be sure electrolyte level is 9/16" above separator plates. Add only distilled water or good quality drinking water. NEVER add additional acid or other chemicals to battery after initial activation.
- 2. The battery should be checked with a hydrometer after every 25 hours of operation. If the specific gravity is less than 1.225 remove battery and recharge.
- 3. Coat the terminals and exposed wiring with a thin coat of grease or petroleum jelly for longer service and protection against electrolyte corrosion.
- 4. The battery should be kept clean. Any deposits of acid should be neutralized with soda and water. Be careful not to get this solution in the cells.

D. STORAGE

- 1. Charge battery using normal methods. NEVER store discharged battery as it will not recover.
- 2. Store in cold, dry place.
- 3. Recharge battery whenever the specific gravity is less than 1.225 before returning to service or every two months, whichever comes first.

E. COMMON CAUSES FOR BATTERY FAILURE ARE:

- 1. Overcharging
- 2. Undercharging
- 3. Lack of water
- 4. Loose hold downs and/or corroded connections
- 5. Excessive loads
- 6. Battery electrolyte substitutes
- 7. Freezing of electrolyte



NOTE

THESE FAILURES DO NOT CONSTITUTE WARRANTY.

INSTALLING THE BATTERY

- 1. Remove the access panel on rear of rider. See figure 5.

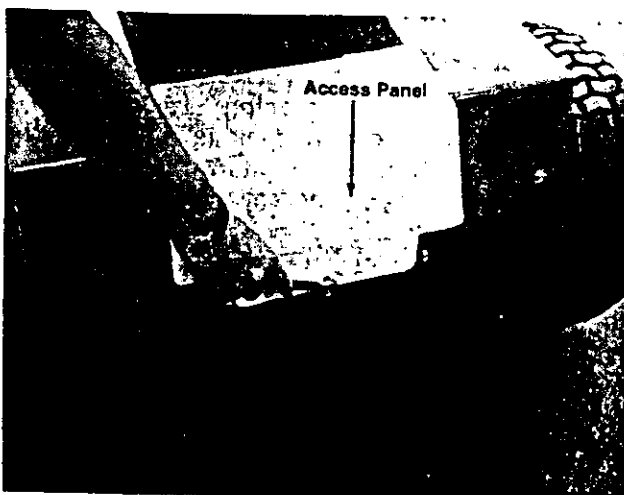

FIGURE 5. REMOVE BATTERY ACCESS PANEL

- Place battery in battery case with the terminals to the front of unit. Negative (-) terminal will be on the left hand side of rider. See figure 6.

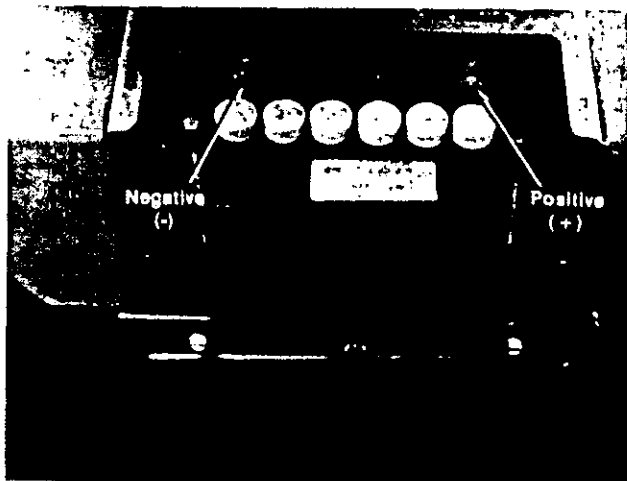

FIGURE 6.

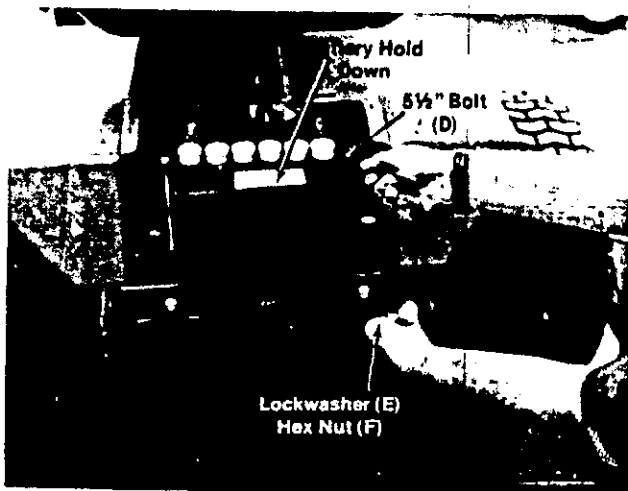

FIGURE 7.

- Place the battery hold down over battery and secure in place with hex screws (D) 5 1/2 inches long, lockwashers (E), and hex nuts (F). See figure 7.
- Attach the positive cable (right hand side of rider) to the positive battery terminal with hex sems screw (G) and hex nut (F). See figure 8.
- Attach the negative cable, grounded, to the negative battery terminal with hex sems screw (G) and hex nut (F). See figure 8.

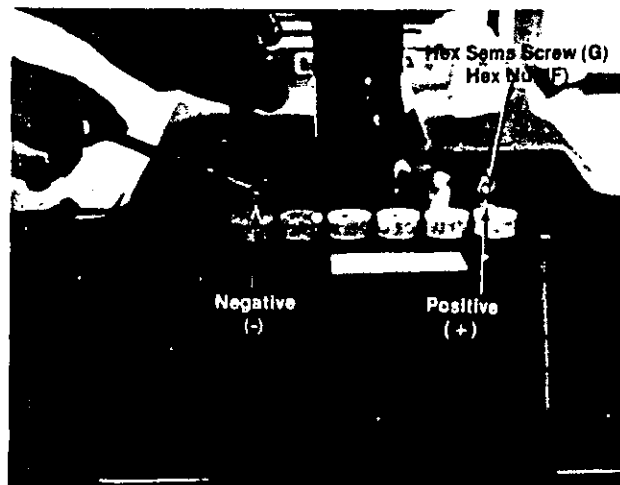

FIGURE 8.

Battery cable connections must be kept tight on the terminals to provide a good contact. To prevent corrosion of the terminals, a light coat of petroleum jelly should be applied.

- Replace battery access panel.

BEFORE STARTING ENGINE

PUT OIL IN CRANKCASE See figure 9.

Place the tractor on a level surface. Remove the oil fill plug and fill the sump to overflowing. Pour slowly. Sump capacity is 3 pints.

For use in temperatures above 40°F, use SAE 30, SAE 10W-30 or SAE 10W-40. For temperatures under 40°F, use SAE 5W-20 or SAE 5W-30.

For temperatures under 0°F, see the engine manual or consult a certified service center for proper engine treatment.

Use a high quality, detergent oil classified "For service SC, SD, SE or MS". Nothing should be added to the recommended oil.

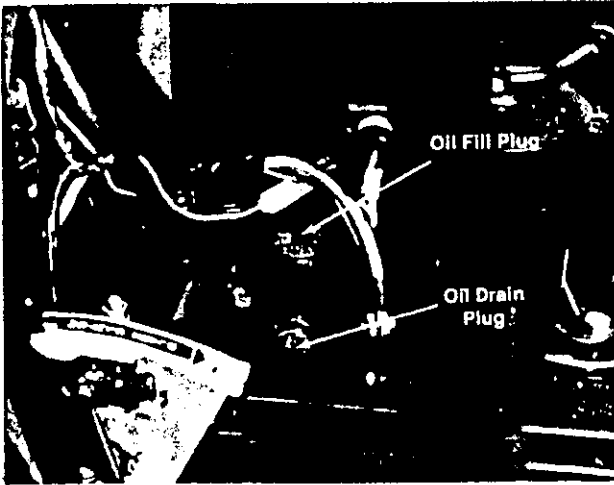

FIGURE 9.

FILL FUEL TANK (See figure 10.)

Fill the fuel tank **completely**. Capacity is approx. one gallon. Use clean, **FRESH**, lead-free or leaded regular grade automotive gasoline. Do not use gasoline that has been stored for a long period.

DO NOT MIX WITH OIL. Be sure the gasoline container is clean. Always wipe up any spill promptly. Use a disposable rag or tissue and **DO NOT SAVE.**



Never add gasoline to a hot engine. Handle gasoline with extreme caution. **NEVER** smoke near gasoline. It is highly explosive and fumes ignite easily.

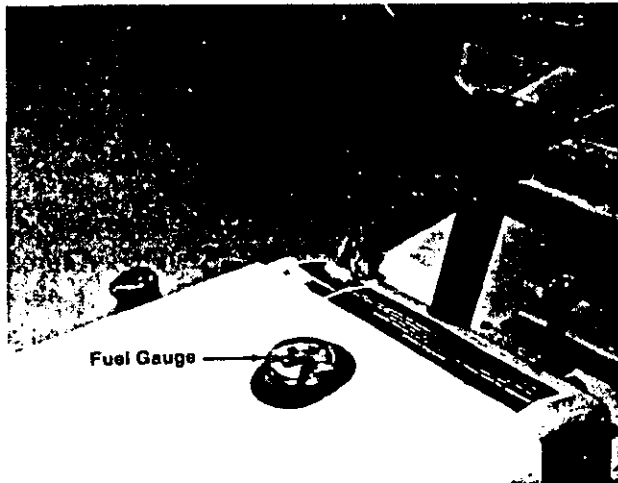

FIGURE 10.

CHUTE DEFLECTOR

To reduce the rider's shipping size, the chute deflector on the mowing deck is placed in the "UP" position. Before you start the engine (at anytime) lower the deflector to its operating position. The deflector can be returned to its "UP" position to minimize storage space.



NEVER operate the cutting unit with the deflector in the storage position.

CONTROLS

The controls may be considered as the Drive Control and the Cutting Control as follows:

- a. **Throttle Control.** The throttle control is used to regulate the engine speed and choke the engine. The engine should be operated from ¾ to full throttle when operating the cutting deck. See figure 11.
- b. **Gear Shift Lever.** The gear shift lever is used to shift into one of three **Forward Gears**, **NEUTRAL** or **REVERSE**. See figure 11.

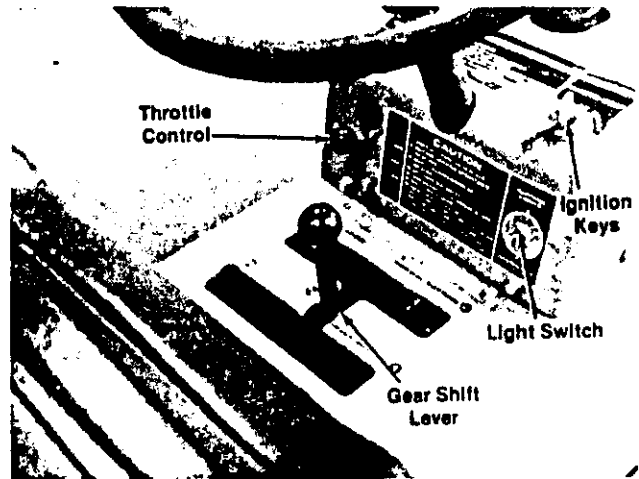

FIGURE 11.

- c. **Light Switch.** Push the light switch up to turn on the lights. The lights will only operate when the engine is running. See figure 11.
- d. **Ignition Switch.** The ignition switch is located on the right side of the dashboard. See figure 11. Turn the key to the **START** position, to start the engine. When the engine is running, let the key return to the **ON** position. To stop the engine, turn the key to the left to the **OFF** position and remove it to prevent accidental starting.

e. **Clutch-Brake Pedal.** The clutch-brake pedal is located on the right hand side of the rider and is operated by depressing it with your right foot. See figure 12.

f. **Lift and Disengagement Lever.** It is used to raise the cutting deck. Pulling it all the way back and locking it disengages the blades. The engine will not start unless the lift and disengagement lever is in the disengaged position. See figure 12.

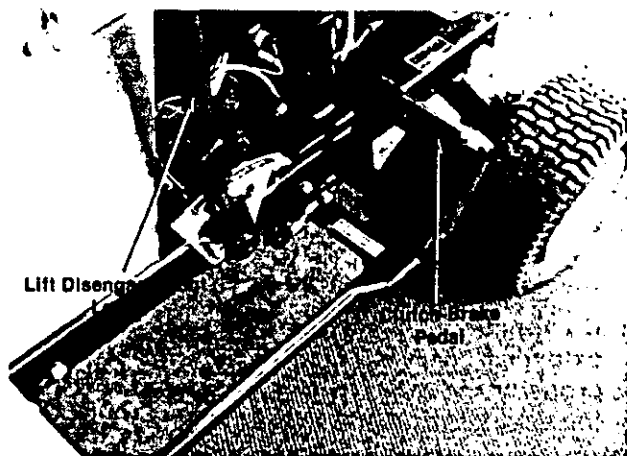

FIGURE 12.

g. **Brake Lock.** The brake lock is located on the right hand side of the mower. To lock the brake, depress the brake pedal and lift up the lock lever. The pedal will stay depressed. To release, depress the pedal. See figure 13.

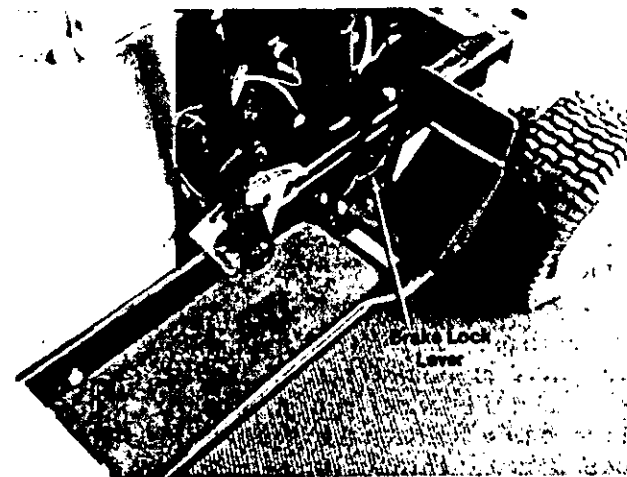

FIGURE 13.

OPERATION OF CONTROLS

TO START ENGINE

THIS RIDER IS EQUIPPED WITH A SAFETY INTERLOCK SYSTEM WHICH PREVENTS THE ENGINE FROM STARTING UNLESS ALL THE CONDITIONS BELOW ARE MET:

- The shift lever must be in the Neutral position.
- The lift disengagement lever must be in the OFF position.

It is recommended that the clutch/brake foot pedal be fully depressed (and locked). This is an added safety precaution.

NOTE

It is recommended that you be on the rider seat when you start the engine. In this position, you can operate the foot pedal and handle all the controls.

To start the engine, position the shift lever and lift disengagement lever as directed in a and b (above). Depress the foot pedal. Move the throttle control lever to Choke and turn the ignition key to the START position. Hold the key in that position until the engine starts.

When the engine starts, move the throttle control lever to slow speed until the engine warms up.

NOTE

Continuous cranking of the starter motor for periods of more than 10 seconds should be avoided. Such stubborn starting signals that the controls are not set as described above or that the engine needs adjustment or service.

To STOP the engine, turn the ignition key to OFF position.

CAUTION

Never lever the rider seat without stopping the engine. Never attempt to shift with the foot pedal fully depressed. Never shift or change speed on a hillside.

TO SHIFT

To shift from Neutral to a Forward speed or Reverse with the engine running, the foot pedal must first be depressed half-way. Then move the shift lever to the desired position and slowly release the foot pedal to engage the drive belt.

If the shift lever will not move to the desired position, release the foot pedal slightly until the meshing gears can be felt. This permits the gears to become aligned. Then move the shift lever to the desired position.

If the shift lever will not move to the Reverse position or to the first Forward position from Neutral, release the foot pedal slightly until the meshing gears can be felt. This permits the gears to become aligned. Then move the shift lever to Reverse or Forward speed.

To shift into Reverse or Forward when the rider is moving in the opposite direction, fully depress the foot pedal to stop the tractor and to disengage the drive belt. Move the shift lever to Neutral, release the foot pedal to the half-way position, move the shift lever to the desired position and slowly release the foot pedal.



CAUTION

A slow foot pedal release will give you a smooth engagement of power.

A fast release will jerk the rider and should be avoided.

A new rider may jerk when power is engaged until the belt is fully seated in the pulley groove. This is normal and to be expected.

The clutch/brake foot pedal gives you positive control in tight places and when you want to slow down momentarily through a difficult area without moving the throttle control or down shifting.

TO ENGAGE CUTTING BLADES

The cutting blades are powered directly off the lower portion of the engine pulley via the mower drive belt. Engine speed directly determines blade speed. For fast blade rotation, move the engine throttle to FAST. For slow rotation, move the throttle to SLOW.

To engage the power to the cutting blades, the lift disengagement lever should be moved out of the OFF position and allowed to move forward by itself. **DO NOT FORCE THE LEVER FORWARD.** The forward movement of the lever tightens the drive belt across the mower deck pulleys and the engine pulley and thus powers the blades. An engagement spring in the mower assembly applies proper pressure to the drive belt automatically.

The shift lever should be used to control ground speeds and the throttle lever should be kept at $\frac{3}{4}$ to full speed for best cutting quality.

ENGINE TIPS

1. If the engine won't start, check the fuel tank to make sure it is full and check the spark plug for spark
2. Be sure the holes in the gas cap are open and will allow air to enter the gas tank.
3. Be sure the air filter is kept in good condition. Any dust which gets past the filter can damage the engine. Also a dirty air filter will reduce the engine's operating efficiency and can cause hard starting.
4. Never use old gasoline in the engine. In addition to bringing on problems with gum and varnish, old gas makes for hard starting.

5. If the engine misses, check the spark plug and plug wire. Dirty plugs should NOT be cleaned. They should be replaced.

If the engine continues to misfire with a new plug, the problem can be loose engine bolts, a leaky head gasket, sticky valves, etc. For these conditions it is suggested a certified service center be contacted for advice.

6. If the engine overheats, the cooling fins may be clogged. Also, a too-lean fuel mixture can cause overheating.
7. Don't put the engine under full power as soon as it starts. Fast RPM before the engine warms up can cause excessive engine wear.
8. Do not idle the engine at too slow a speed for extended periods. Oil will not circulate properly and excessive wear can result... also the engine can overheat.

MOWING SUGGESTIONS

Mowing of lawns should be done frequently, on a systematic basis. If grass is allowed to grow excessively tall before cutting, the under part of the grass, which has been protected from the sun, will be exposed and possibly damaged. This grass then tends to become coarse and often loses its deep green color. Frequent cutting promotes new more finely textured blade growth.

The root system of Kentucky Bluegrass renews itself every Spring. If mowing is done before the roots have had a chance to grow, the root system won't develop fully and the quality of the grass will suffer, as will its ability to withstand the demands of a tough summer. With this grass the first mowing should not be done until new growth is at least two inches.

A common error is to let grass grow longer in hot weather to protect it from the sun and heat. When long grass is finally cut, it will be brown or gray... and the tender bottom growth will not be able to battle the weather and will lose quality. Twice a week cutting is best throughout the summer, hot or not, right up to the time growth stops in the late Fall.

When cutting tall heavy grass or on rough ground, place the cutting unit in the highest cut position and the rider in the slowest ground speed. Gradually reduce the cutting height over several passes.



IMPORTANT

Keep the underside of the mower deck clean and keep the blades sharp for good quality cutting. Dull blades will bruise and tear the grass and cause a yellowing appearance.

MOWING PATTERNS

The side discharge mowing deck will throw grass clippings to the right. You can take advantage of this as follows:

- a. If you are going to remove clippings after you mow, start mowing at one side of your lawn and proceed around the lawn in a clockwise pattern. Using this pattern, the discharge chute will distribute clippings to a center spot for easier pick-up and removal. See figure 14.

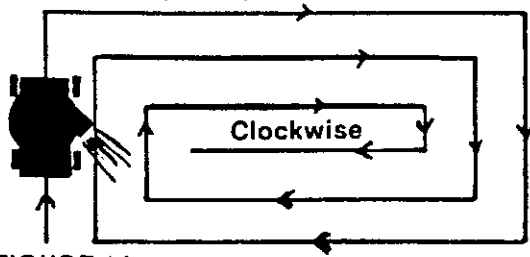

FIGURE 14.

Keep in mind, however, that in subsequent passes a poor quality of cut can result because the mower will have to cut BOTH grass and the clippings which have been thrown toward the center of the lawn. If the clippings are heavy and if the grass is also heavy, the combined load may cause the mowing deck to clog. In such situations it is best to mow in a counterclockwise direction so clippings will not be re-cut. See figure 15.

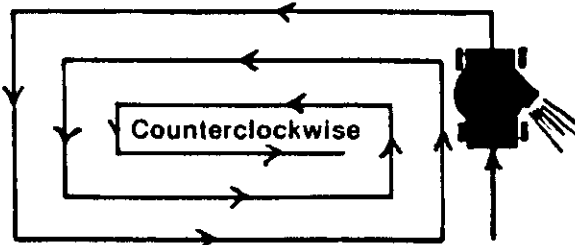

FIGURE 15.

- b. If you are not going to remove grass clippings, a mowing pattern is of no concern. However, you should criss-cross or generously overlap each pass to avoid missed spots. See figure 16.

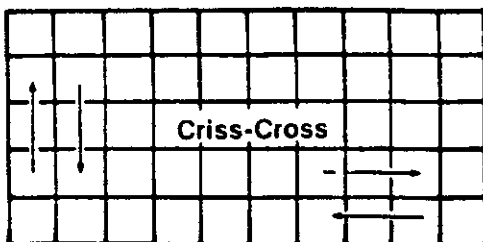



FIGURE 16.

With the rear discharge mowing deck you have freedom of choice between the three patterns shown here. However, overlap each pass to avoid missed spots.

CUTTING TIPS

1. When cutting tall, heavy grass, don't try to cut to the desired height in one pass. Set the blades higher than the final height and make several passes, gradually reducing grass height. Maintain high engine speed at all times for fast blade rotation and select ground speed suitable for ground conditions with the shift lever.
2. When cutting deep grass, it is recommended that the clipping be raked off the lawn... or removed with a Trail Sweep or Vac-Sweep.
3. Cut the lawn before spreading fertilizer, weed killer, etc. Otherwise the blade action will suck up the material you have spread and discharge it through the chute along with the grass clippings.
4. Mow before you water the lawn. Wet grass clippings are likely to cling to the underside of the mowing deck housing.
5.  **CAUTION**
Always check the gasoline supply BEFORE you start to use the tractor to be sure you have enough gasoline in the tank to do the entire job. If a refill is necessary let the engine cool before pouring gasoline in the tank. A hot engine can ignite gasoline, causing an injurious explosion.
6. If grass develops a brown look after cutting, the cause can be dull cutting blades... or cutting was done at too slow a blade speed. Keep the blades sharp and the engine at $\frac{3}{4}$ to full throttle.
7. It is a good idea to have an extra set of blades on hand. This will allow you to use the mower while one set is being sharpened. Always have the blades sharpened by a qualified service center with proper balancing equipment. For blade replacement use only the authorized original blade, see the parts list for the correct part number.
8. Where grass has been trampled, it is a good idea to rake such areas before mowing. This will make the grass stand up for a better cut.
9. If you try to cut too close to small trees the mower can scrape or cut into the tree bark, causing damage. It is better to adopt a policy of cutting reasonably close to such objects and clipping close with hand clippers.

LUBRICATION

After every 5 hours of operation, lubricate the points listed below with SAE 20 engine oil (unless otherwise noted).

- (A) Oil the pedal pivot point
- (B) Oil all connecting rod points
- (C) Oil all pivot points (rider & mower)
- (D) Oil the mower control lever
- (E) Oil the throttle control cable
- (F) Oil the mower deck wheels
- (G) Transmission (See maintenance section)
- (H) Engine crankcase (See maintenance section)
- (I) Grease the steering gear (Caution: Keep grease off belts) See figure 17.

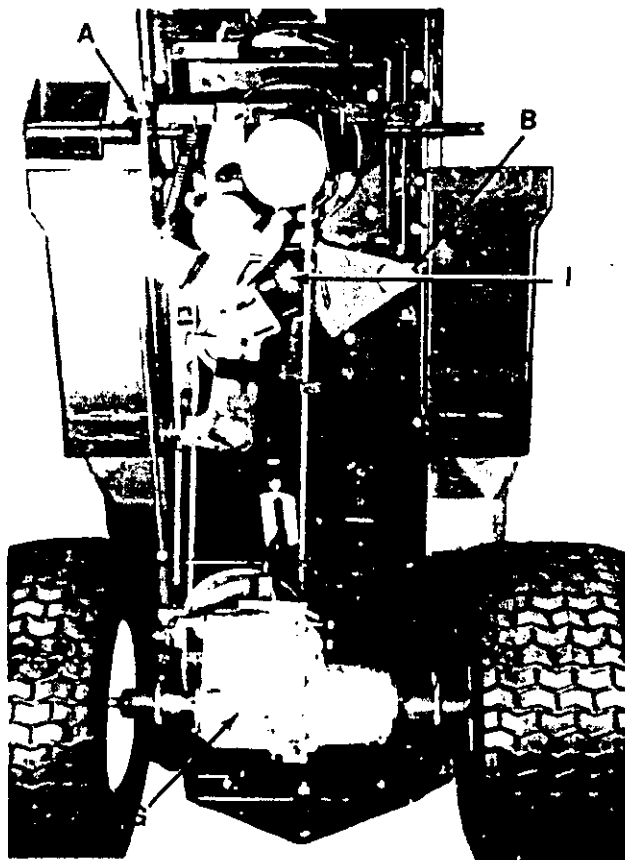

FIGURE 17.

MAINTENANCE

Your new rider will give excellent service for many years if given reasonable care and maintenance, as follows:

1. Check the oil level in the crankcase frequently, at least every 5 hours of operation. When checking oil level be sure the area around the oil fill cap is cleaned of all debris before it is removed. Otherwise debris can fall into the crankcase and cause damage.

Change oil every 25 hours of operation... more frequently if operated under dusty conditions.

On new engines, it is important that the oil be changed after the first few hours of operation. Change between the first 2-5 hours of operation.

For the proper grade and weight of oil to use, see **BEFORE STARTING ENGINE**, page 8.

2. AIR CLEANER

Under normal operating conditions, the air cleaner, located on top of the carburetor, must be serviced after every ten hours of use. Under extremely dusty operating conditions the air cleaner must be serviced after every hour of operation. Refer to figure 18.

When assembling the air cleaner, make certain the lip of the foam element extends over edge of the air cleaner body. The foam element will form a protective seal.

- Step A. Remove two screws and lift off complete air cleaner assembly.
- Step B. Remove screen and spacers from foam element.
- Step C. Remove foam element from air cleaner body.
- Step D. 1. Wash foam element in kerosene or liquid detergent and water to remove dirt.
2. Wrap foam in cloth and squeeze dry.
3. Saturate foam in SAE 30 engine oil, then squeeze out excess oil.
4. Assemble parts, fasten to carburetor with screw.

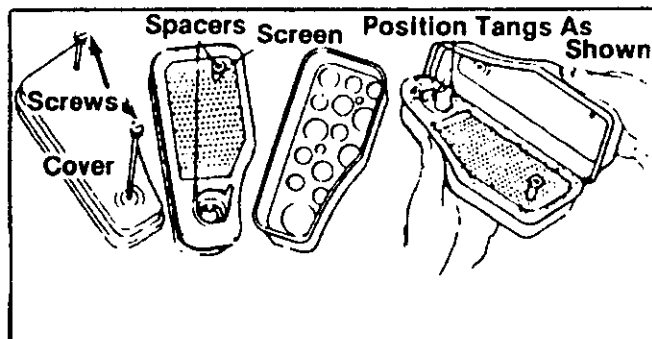

FIGURE 18. AIR CLEANER

3. Keep the engine's air cooling fins clean.
4. Keep the underside of the mower deck clean. **BE SURE** that blades are securely fastened and are kept sharp.

5. Each time you use the rider be sure you check the condition of the nuts, bolts, cotter pins, etc. to be sure all are tight and secure properly.
6. The transaxle transmission is pre-lubricated at the factory. Check the oil level every 25 hours by removing the oil fill plug. If the oil is below the level of the plug opening, fill to that level with SAE 90 extra heavy duty transmission oil.
Transmission oil should be changed every 50 hours of operation or once each season.
7. The disc brake pads wear and may require replacing occasionally. This replacement is best done by a qualified service dealer.



CAUTION

Brakes should be kept in good operating condition to avoid possible injury or damage to the operator or tractor.

8. Should excessive vibration develop, check for the cause immediately. Check for a damaged blade, damaged bearing shaft, frayed belt, an obstruction, etc. DO NOT operate the rider again until the cause is found and corrected.

SPARK PLUG

The spark plug gap should be cleaned and reset to a 0.030-inch clearance once a season (see figure 19). Spark plug replacement is recommended at the start of each mowing season.



NOTE

Whenever the spark plug is removed for cleaning, it is advisable to replace the spark plug gasket with a new gasket.

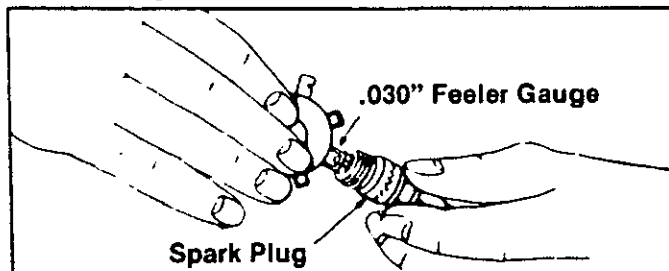

FIGURE 19. SPARK PLUG CLEARANCE
REPLACING BLADE



Before beginning work on the cutter blade, remove the spark plug from the cylinder.

Removing and Sharpening Blades. See figure 20.

Each blade is secured to the blade mount adapter plate with two bolts, nuts and lockwashers. The blade is removed by removing these bolts and nuts and pulling the blade away from the adapter.

When replacing the blades be sure the blade offset and the sharp edges are positioned as shown at the right. Tighten the retaining bolts securely. Do not re-use worn or stripped fasteners.

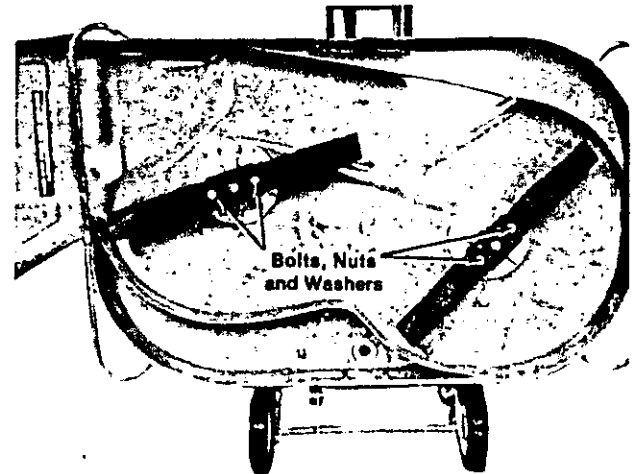

FIGURE 20. BLADE REMOVAL
ADJUSTMENTS



CAUTION

MAKE ALL ADJUSTMENTS (REGARDLESS OF HOW MINOR) WITH THE IGNITION KEY IN THE OFF POSITION, WITH THE IGNITION WIRE REMOVED AND SECURED AT LEAST 1" AWAY FROM THE SPARK PLUG, WITH THE SHIFT LEVER IN NEUTRAL AND THE BLADE CONTROL LEVER IN THE OFF POSITION. IN ADDITION THE WHEEL SHOULD BE BLOCKED TO PREVENT ACCIDENTAL MOVEMENT.



NOTE

To insure safe operation of your unit, ALL nuts and bolts must be checked periodically for correct tightness.

WHEEL ADJUSTMENT

The caster (forward slant of the king pin) and the camber (tilt of the wheels out at the top) requires no adjustment. Automotive steering principals have been used to determine the caster and camber on the tractor. The front wheels should toe-in 1/8 inch.

To adjust the toe-in follow these steps.

1. Remove the elastic locknut and drop the tie rod end from the wheel bracket. See figure 21.
2. Loosen the hex jam nut on tie rod.
3. Adjust the tie rod assembly for correct toe-in.

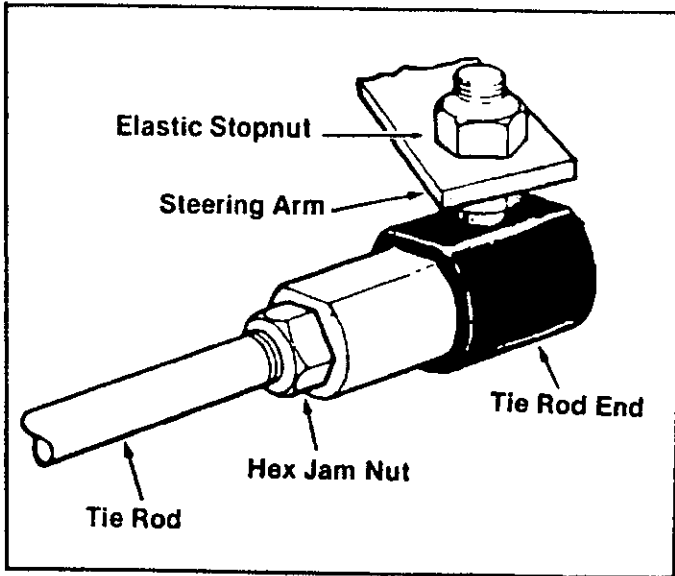

FIGURE 21. TIE ROD ADJUSTMENT

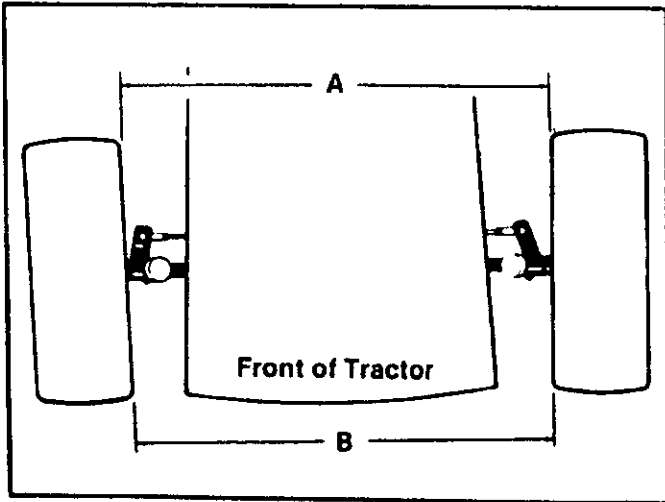

FIGURE 22. TOE-IN DIAGRAM

Dimension "B" should be approximately 1/8" less than Dimension "A". See figure 22.

- A.) To increase Dimension "B", screw tie rod into tie rod end.
- B.) To decrease Dimension "B", unscrew tie rod from tie rod end.
- C.) Reassemble tie rod. Check dimensions. Readjust if necessary.

ADJUSTING CARBURETOR CHOKE

Proper choke adjustment is dependent upon proper adjustment of remote controls on the powered equipment.

To Check Operation of Choke-A-Matic Controls:

Move control lever to CHOKE position. (See figure 11.) The carburetor choke should be closed.



The air cleaner can be removed to check the operation of the choke.

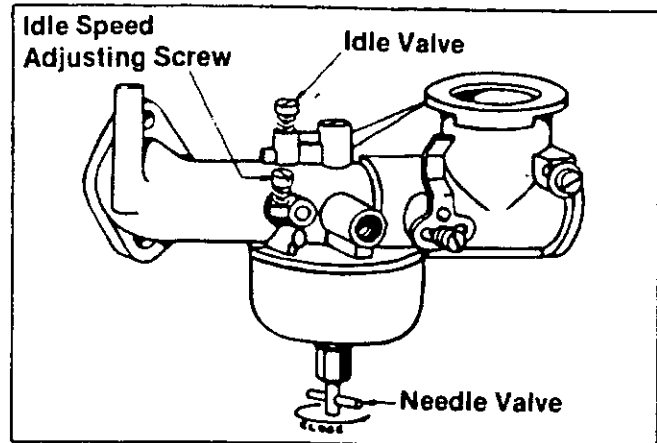

FIGURE 23. CARBURETOR ADJUSTMENT

To Adjust:

Place control lever on equipment in FAST (high speed) position. Loosen control casing clamp screw B. Move control casing A and wire until lever D touches choke operating link at C. Tighten casing clamp screw B. See figure 24.

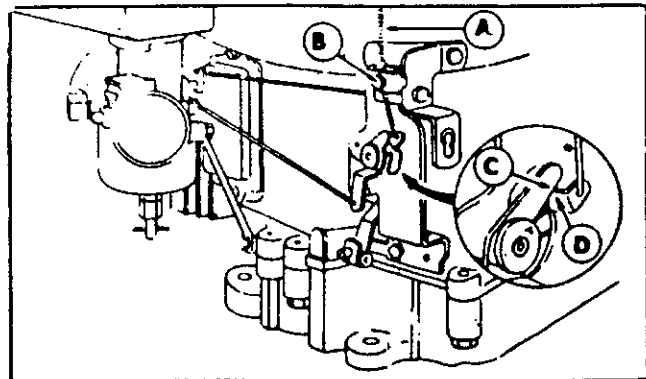

FIGURE 24. CHOKE ADJUSTMENT

ADJUST THROTTLE CONTROL See figure 25.

1. Move the throttle control lever located on the control panel to the FAST position.
2. Loosen the cable clamp screw holding the throttle control cable to the engine bracket.
3. Move the cable and wire until the throttle lever is in contact with the Choke lever. Tighten the cable clamp screw.
4. Operate the throttle control lever several times to check movement of the throttle to full Choke and FAST positions.

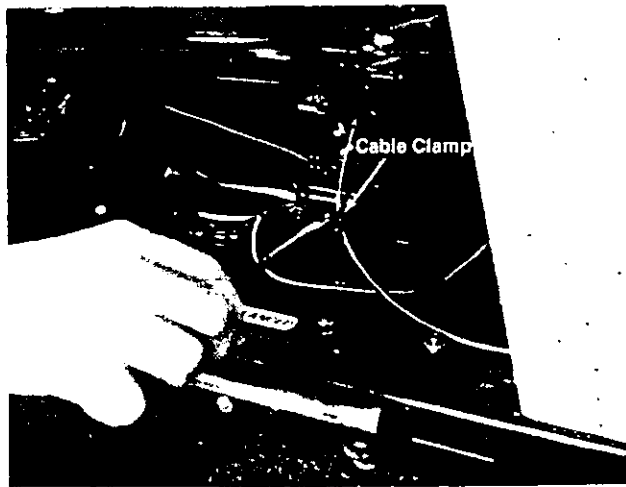

FIGURE 25.

REMOVE CUTTING UNIT

1. Lower the cutting unit to the lowest height of cut. Move the mower lever back into the OFF position.
2. Remove the hairpin cotter and pull out the hitch pin. See figure 26.

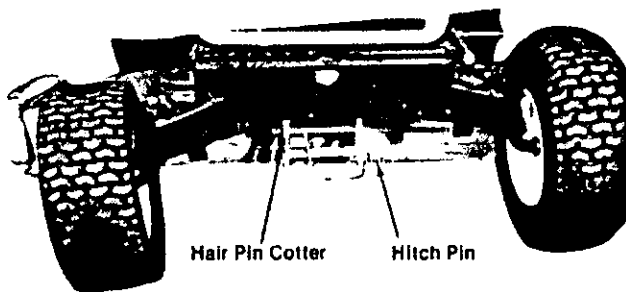

FIGURE 26.

3. Slip the mower drive belt off the bottom rim of the engine drive pulley and out of the mower drive idler and belt restrictor. Move the mower lever out of the OFF Position and release it to enable removal of the belt from between the blade brake mechanism.
4. Lift the front end of the cutting unit by the mower lift handle and move back slightly to disconnect the mower hitch rod from the hitch bracket and lower the cutting unit. See figures 27 and 28.
5. Push the front of the rider by the lift bar and roll the front wheels back over the top of the cutting unit for removal.

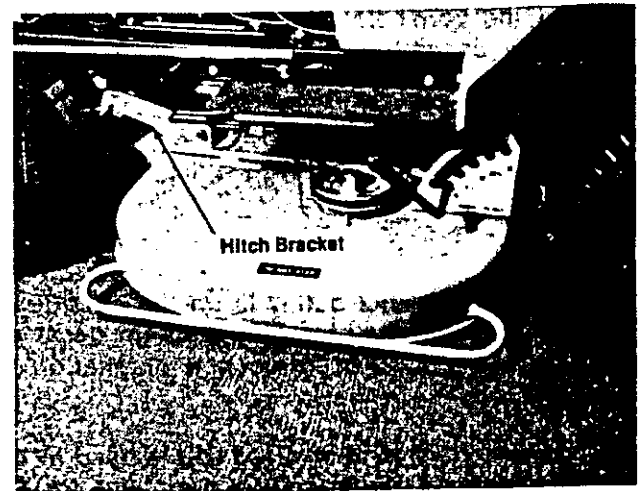

FIGURE 27.

6. Reverse these steps to re-install the cutting unit. Refer to the belt diagram decal on the mower deck for correct drive installation.



Make sure the mower lever is in the engaged position (forward) when installing the cutting unit. Position the drive belt between the blade brake mechanism before moving the lever to the OFF position.

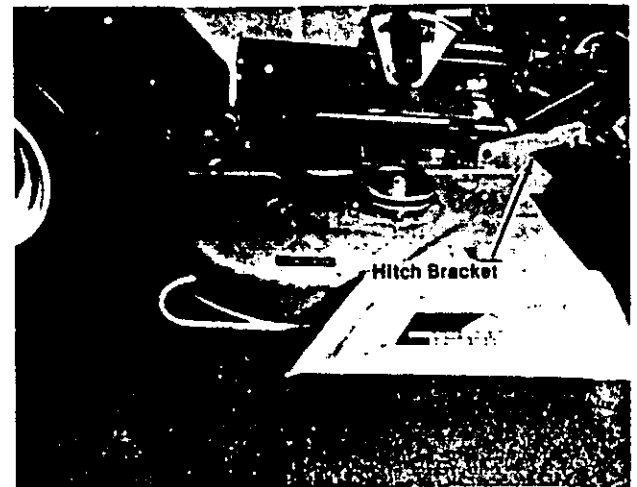

FIGURE 28.

REPLACE MOWER BELT

See figure 29.

1. Remove the cutting unit from the rider as described above.
2. Release the tension on the idler arm and pulley and lift the worn belt from the blade pulleys.

3. Pull the worn belt (from the rear) to the double pulley assembly and lift the belt over the pulley.
4. Reverse the procedure in replacing the new belt.
5. Be sure the idler pulley is on the outside of the belt. Refer to the belt diagram decal on the mower deck for correct belt installation.
6. Be sure only an authorized belt is used in the replacement. Refer to the parts list for the part number of the correct replacement belt.

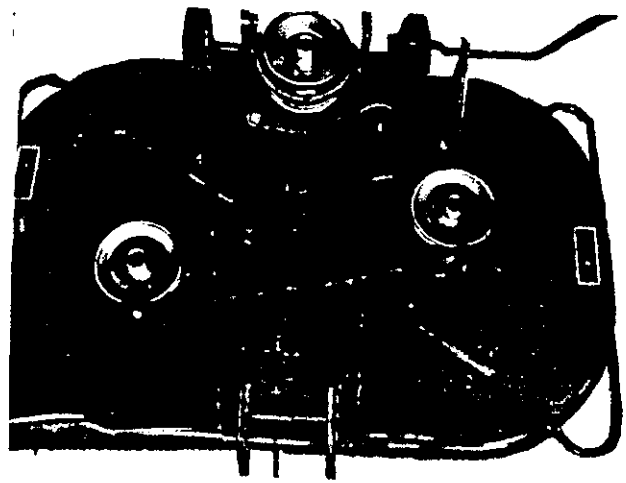

FIGURE 29.

ADJUST MOWER BELT

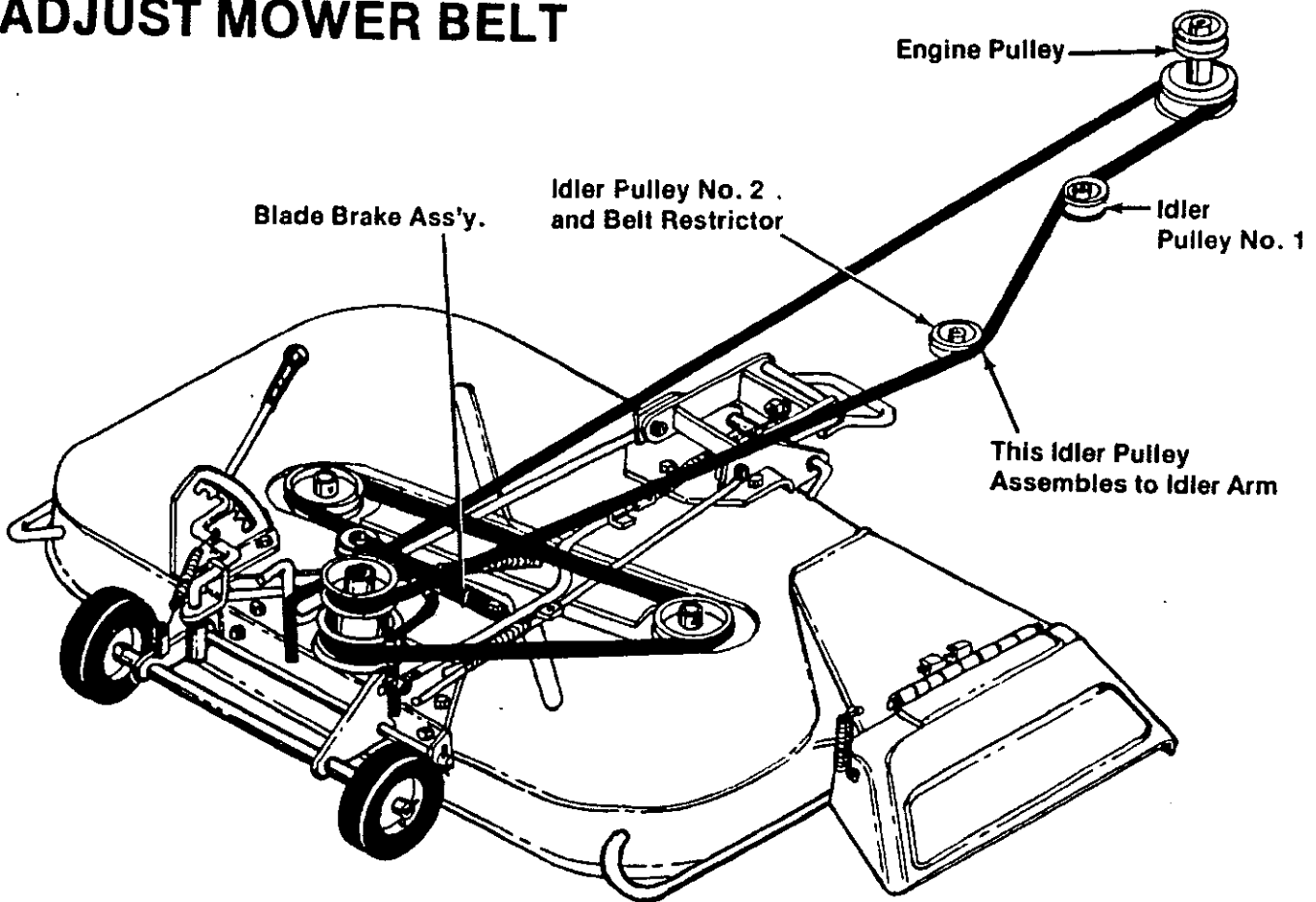

FIGURE 30.

This belt is of a special, high strength construction. However, after 5-10 hours of operation, a slight adjustment may be required. To adjust, move the idler pulley towards the engine pulley about 1/8". To check the belt tension, raise mower height of cut to the highest position. **The belt must release when disengaged.**

Repeat the adjustment if more belt take-up is needed. Additional adjustment can be obtained by movement of idler pulley #2 after idler pulley #1 has been moved the full length of the adjustment slot. To obtain additional adjustment, move idler pulley #2 towards the outside. When the idler pulley has been tightened, relocate the belt restrictor in the positioning slot.

REPLACE TRANSMISSION BELT

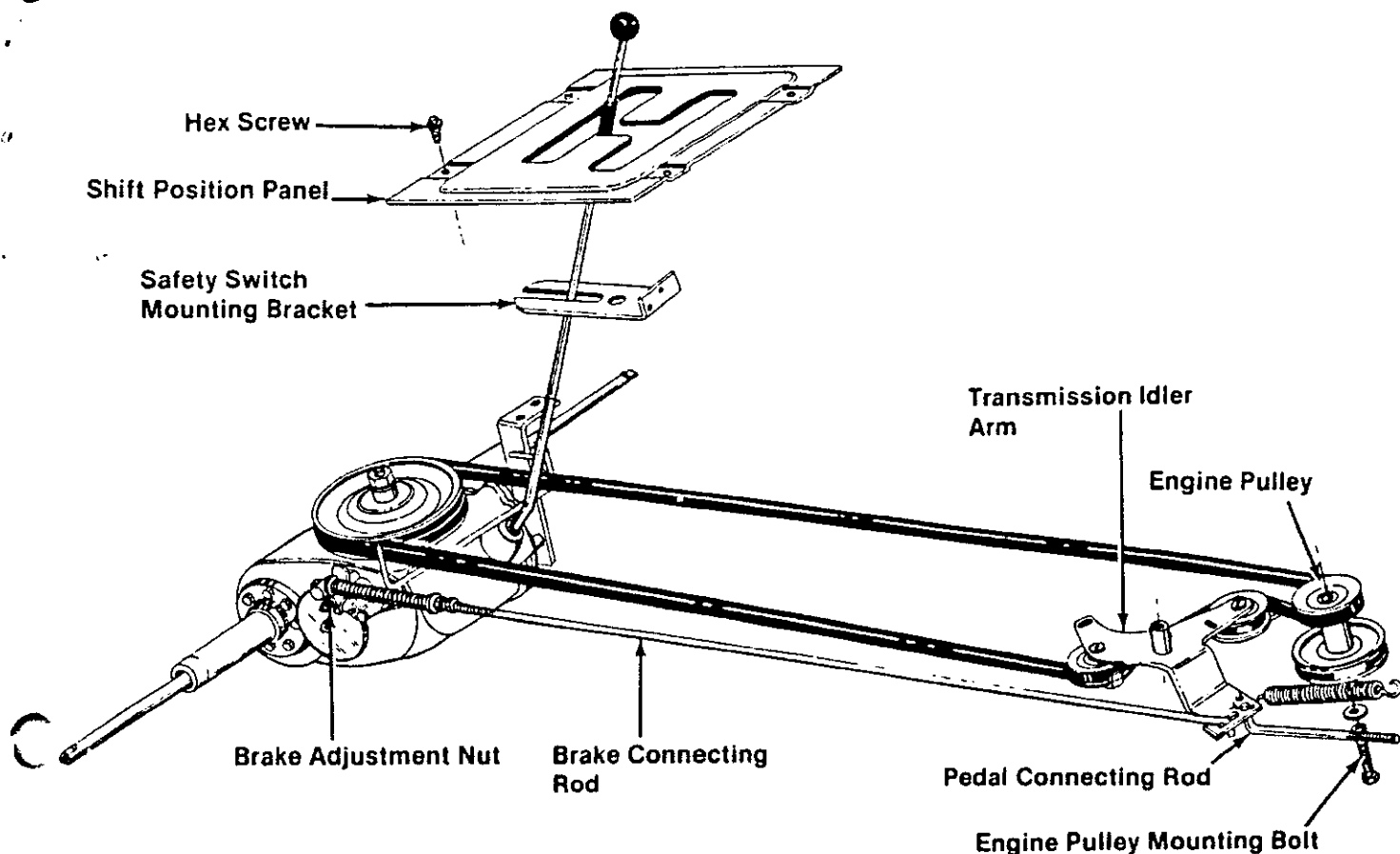

FIGURE 31.

1. To facilitate removal and replacement of the tractor's transmission drive belt, remove the mower deck as explained previously. Drain the oil and gasoline from the engine...remove the battery...and then tilt the tractor on its side to expose the belt assembly.
2. Remove the bolts holding the shift position panel and remove the panel.
3. Remove the mower idler spring and the mower drive idler arm connecting rod.
4. Remove the engine drive pulley mounting bolt. Loosen the set screw in the lower engine pulley hub and remove the pulley.
5. Remove the bolt and bushing from the safety switch bracket and slip off the shift lever.
6. Remove the old belt, slipping it first up and off the transmission pulley, off the engine pulley, and off the two transmission drive idlers. Then work the belt up and over the transmission lever for removal.
7. To install a new belt, reverse the above steps. Be sure the tapered side of the belt is in the pulley groove. In replacement, use only an authorized, original equipment belt. Refer to the parts list for the part number of the proper belt.

Make sure the belt is inside the belt guide rods (near the engine drive pulley and the transmission pulley) and inside the two belt restrictor brackets.

The front transmission idler (flat) should be on the outside of the belt and the rear transmission drive idler (V type) should be on the inside of the belt. Refer to the installation diagram under the right foot rest.
8. Replace the shift position panel.
9. After the new belt is in position, the clutch and brake should be adjusted. Refer to the Clutch/Brake adjustment on page 18.

ADJUST CLUTCH/BRAKE

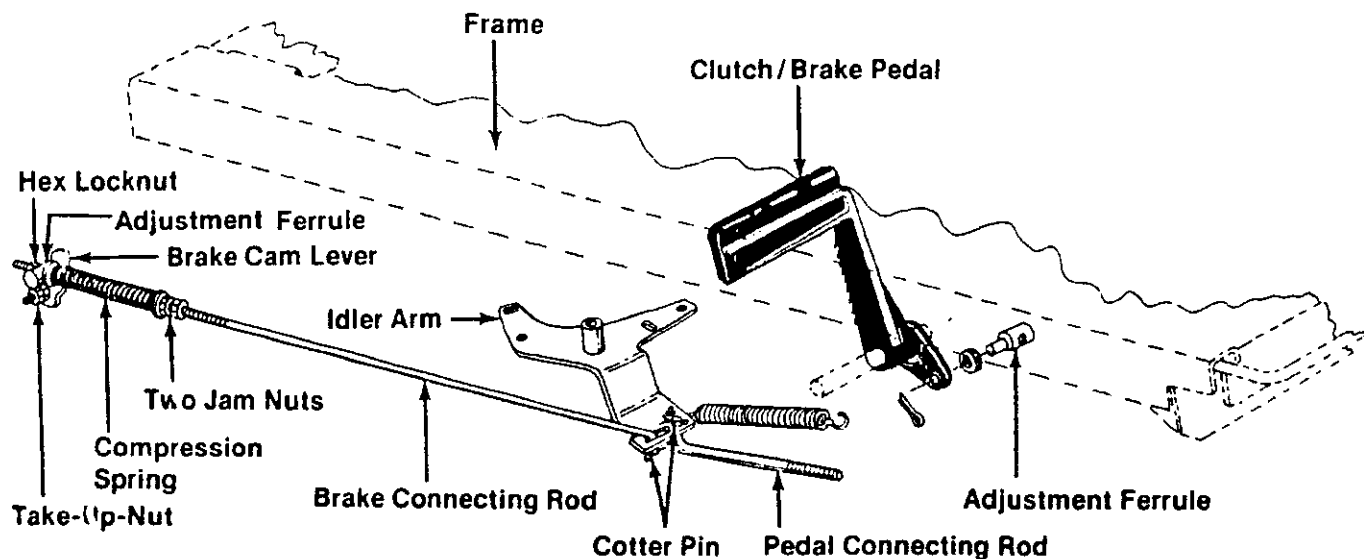

FIGURE 32.

1. To adjust the vertical position of the brake and clutch pedal remove the cotter pin from the pedal connecting rod and thread the rod out or in as required to correctly re-position the pedal.
2. Normal wear of the brake disc may necessitate a slight adjustment to assure good braking action without too much pedal movement. Turn the brake adjustment nut clockwise $1/8$ turn at a time and check. Move the transmission shift lever to Neutral and roll the tractor by hand and check the braking action by depressing the brake pedal all the way down.



CAUTION

Tighten the brake adjustment nut ONLY $1/8$ turn at a time to prevent over-tightening and thus causing brake drag and undue wear.

3. The brake connecting rod may need adjustment occasionally if stretching occurs in the transmission drive belt or when a new belt is installed.

The front end of the rod connects into the slotted hole in the transmission drive idler arm and may be disconnected for adjustment by removing the cotter pin and washer.

With the brake-clutch pedal in the released position (drive) and the brake connecting rod held back toward the brake, adjust the rod by threading it in or out until the rod end is centered in the idler arm slot. This adjustment should be maintained in order to avoid brake dragging or belt slipping and to allow movement of the pedal to the clutch position and before application of the brake.

NOTES

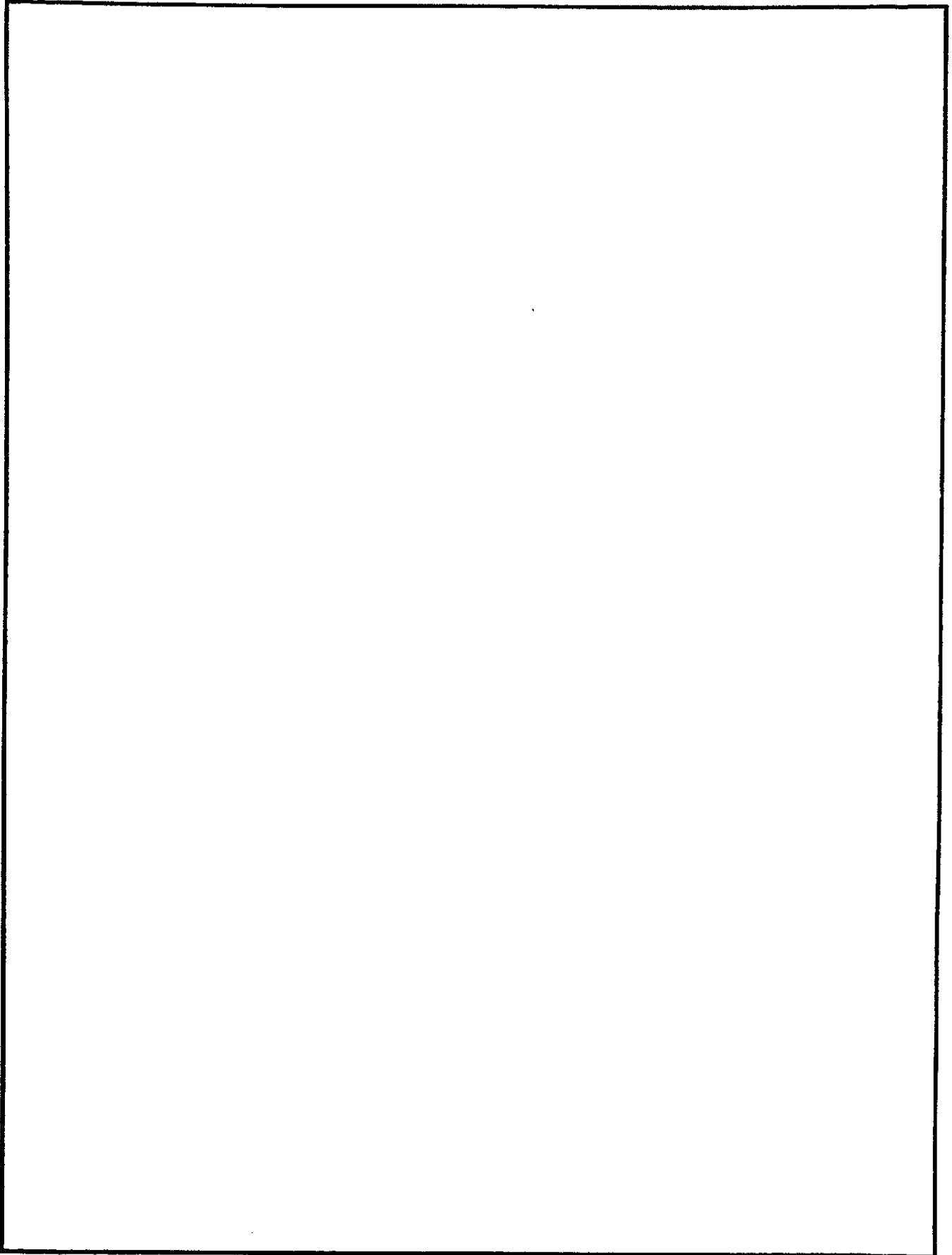
A large, empty rectangular box with a black border, intended for writing notes. The box occupies most of the page area below the title and above the footer.

13875A-8
13885A-8

IF YOU WRITE TO US ABOUT THIS ARTICLE
OR IF YOU ORDER REPLACEMENT PARTS AL-
WAYS MENTION THIS MODEL & SERIAL NO
MODEL

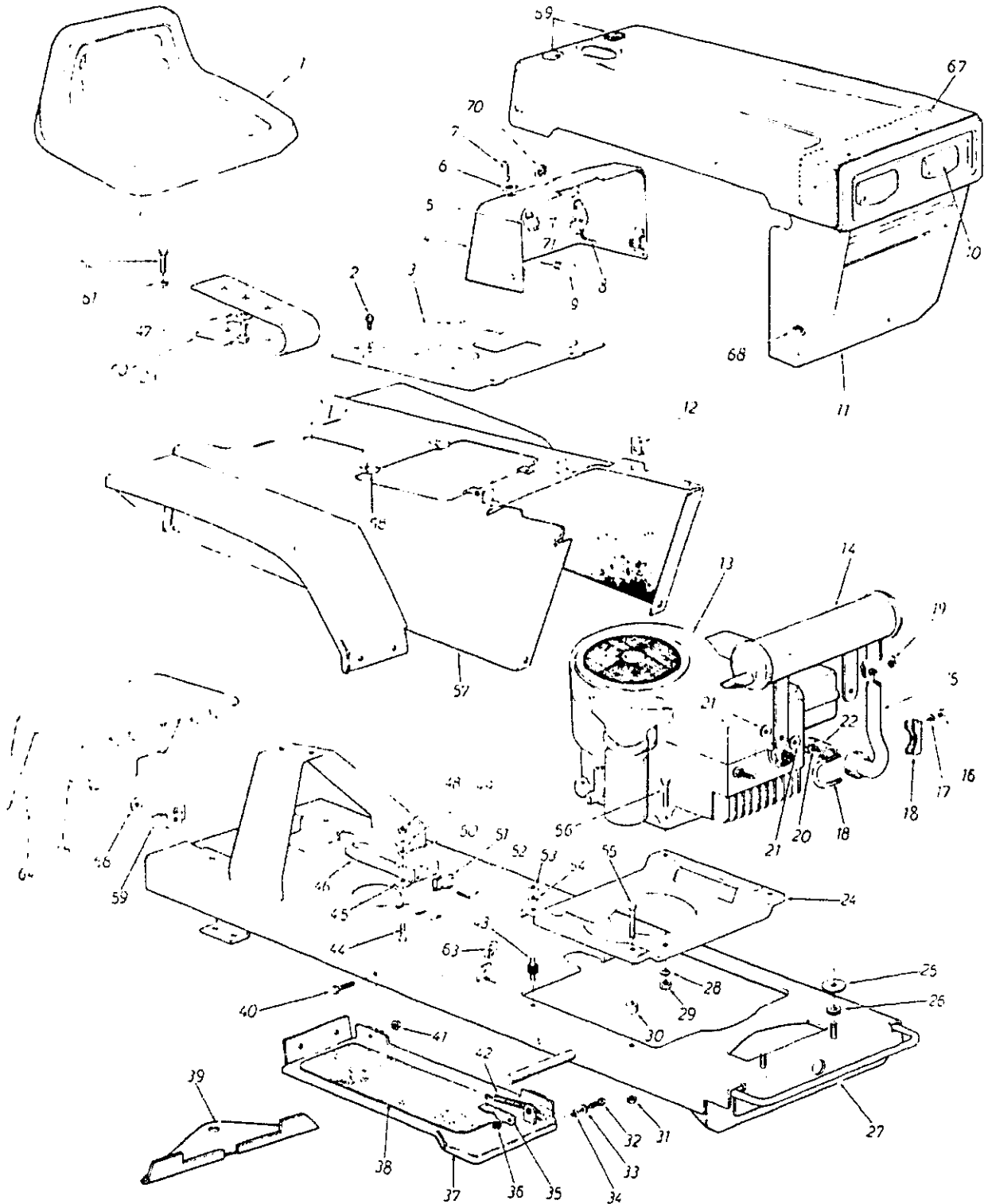

PARTS LIST FOR MODELS 13875A-8 AND 13885A-8

REF. NO.	PART NO.	COLOR CODE	DESCRIPTION	NEW PART	REF. NO.	PART NO.	COLOR CODE	DESCRIPTION	NEW PART
1	4164-018		Seat—Low Back (13875A-8)		36	712-0107		Hex Cent. L-Nut 1/4-20 Thd.	
	4164-020		Seat (13885A-8)		37	2207-004		Foot Rest Ass'y.—R.H.	
2	710-0377		Hex Sems Scr. 1/4-20 x .62" Lg.*			61585		Foot Rest Ass'y.—L.H. (Not Shown)	
3	22242		Shift Position Panel		38	42381		Foot Rest Pad	
4	3159-015		Control Panel Ass'y.		39	3609-509		Rear Hitch Brkt.	
5	725-0267		Ignition Switch		40	710-0118		Hex Scr. 5/16-18 x .75" Lg.*	
6	—		Part of Ref. No. 5		41	712-0158		Hex Cent. L-Nut 5/16-18 Thd.	
7	725-0201		Ignition Key		42	1642-116		Extension Spring	
8	42003		Throttle Control		43	41382		Engine Shock Mount	
9	725-0506		Light Switch		44	710-0118		Hex Scr. 5/16-18 x .75" Lg.*	
10	1744-002		Head Light		45	736-0264		FI-Wash. 3/8" I.D. x 1.00" O.D. x .127	
	1743-006		Head Light—Lens		46	1609-450		Switch Mounting Brkt.	
	1744-003		Head Light—Bulb		47	736-0921		L-Wash. 1/2" Scr.*	
11	15156 —497		Hood and Grille Ass'y.		48	712-0158		Hex Cent. L-Nut 5/16-18 Thd.	
12	42005		Speed Nut for 1/4-20 Thd.		49	736-0264		FI-Wash. 3/8" I.D. x 1.00" O.D. x .127	
13	—		8 H.P. Engine (13875A-8)		50	1657-074		Pivot Bushing .50 O.D. x .328 I.D. x .110 Lg.	
	—		10 H.P. Engine (13885A-8)		51	725-0505		Safety Switch	
14	4195-018		Muffler Ass'y. (13885A-8)		52	1501-029		Slotted Rd. Hd. Scr. #4-40 x .75" Lg.	
15	2187-012		Exhaust Pipe Ass'y. (13885A-8)		53	712-0267		Hex Nut 5/16-18 Thd.*	
16	1694-035		Exhaust Pipe Clamp 1-3/8" Dia. (13885A-8)		54	736-0119		L-Wash. 5/16" Scr.*	
17	—		Part of Ref. No. 16 (13885A-8)		55	710-0442		Hex Scr. 5/16-18 x 1.50" Lg.*	
18	—		Part of Ref. No. 16 (13885A-8)		56	710-0528		Hex Scr. 5/16-18 x 1.25" Lg.*	
19	1694-022		Exhaust Pipe Clamp 1 1/4" Dia. (13885A-8)		57	4118-074		Rear Frame Cover Ass'y.	
20	712-0158		Hex Cent. L-Nut 5/16-18 Thd.		58	42104		Speed Nut for 1/4-20 Thd.	
21	736-0159		FI-Wash. .344 I.D. x .88 O.D. x .063 (13885A-8)		59	712-0122		Nut Retainer 5/16-18 Thd.	
22	1745-029		Muffler Pipe Nippel(13885A-8)		60	41379		Seat Spring	
23	710-0493		Hex Scr. 1/2-13 x 1.00" Lg.*		61	736-0119		L-Wash. 5/16" Scr.*	
24	4641-019		Engine Base Plate		62	710-0118		Hex Scr. 5/16-18 x .75" Lg.*	
25	736-0133		FI-Wash. .406" I.D. x 1.25" O.D. x .100		63	40115		Speed Nut	
26	1543-058		Rubber Wash. .38 I.D. x .75 O.D. x .190		64	4709-039		Battery Access Panel	
27	15150		Frame Ass'y.		65	710-0259		Hex Sems Scr. 5/16-18 x .62" Lg.*	
28	736-0119		L-Wash. 5/16" Scr.*		66	736-0159		FI-Wash. .344 I.D. x .88 O.D. x .063	
29	712-0267		Hex Nut 5/16-18 Thd.*		67	3709-021		Head Light Panel	
30	22550		Engine Mounting Spacer		68	1538-022		Hex Nut Flange Self Lock 5/16-18 Thd.	
31	712-0158		Hex Cent. L-Nut 5/16-18 Thd.		69	42425		Foam Pad	
32	710-0252		Hex Scr. 1/4-20 x .75" Lg.*		70	41433		Plastic Plug	
33	736-0463		FI-Wash. .281 I.D. x .62 O.D. x .059		71	710-0315		Hex Wash. Hd. Self Tap Scr. #8-32 x .62" Lg.	
34	1657-076		Pivot Bushing .50 O.D. x .265 I.D. x .217 Lg.						
35	1609-477		Parking Brake Brkt.						

*For faster service obtain standard nuts, bolts and washers locally. If these items cannot be obtained locally, order by part number and size as shown on parts list.

(497—Yard-Man Red) When ordering parts if color or finish is important, use color code shown at left. (e.g. Yard-Man Red Finish 15156 (497).)

The engine is not under warranty by the mower manufacturer. If repairs or service is needed on the engine, please contact your nearest authorized engine service outlet. Check the "Yellow Pages" of your telephone book under "Engines — Gasoline."



13875A-8
13885A-8

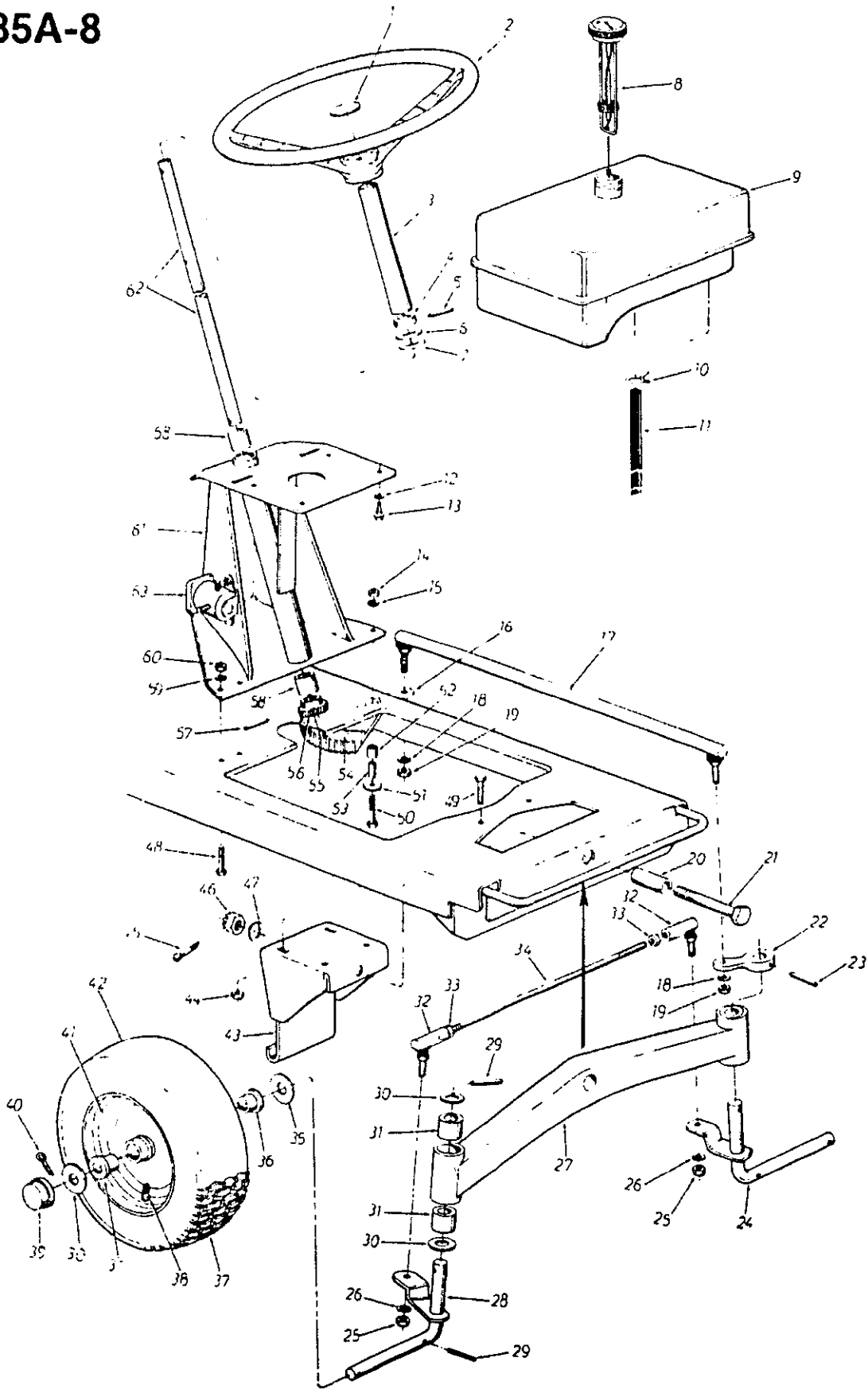

PARTS LIST FOR MODELS 13875A-8 AND 13885A-8

REF. NO.	PART NO.	COLOR CODE	DESCRIPTION	NEW PART	REF. NO.	PART NO.	COLOR CODE	DESCRIPTION	NEW PART
1	1674-051		Steering Wheel Cap		33	712-0116		Hex Ins. L-Nut 3/8-24 Thd.	
2	3738-005		Steering Wheel		34	22259		Tie Rod	
3	1624-181		Steering Post Spacer		35	736-0134		Fl-Wash. .812" I.D. x 1.38"	
4	22243		Collar—Steering Shaft					O.D. x .100	
5	715-0101		Spring Pin Spiral 1/4" Dia. x 1.50" Lg.		36	42414		Flange Bearing	
6	1543-047		Washer Bowed .81 I.D. x 1.15 O.D.		37	734-0798		Front Wheel Ass'y. Comp.	
7	736-0256		Fl-Wash. .635 I.D. x 1.00" O.D. x .03		38	734-0255		Air Valve	
8	41618		Gas Gauge		39	41502		Hub Cap	
9	4733-004		Gas Tank		40	714-0115		Cotter Pin 1/8" Dia. x 1.00" Lg.*	
10	723-0157		Hose Clamp 1/2" O.D. Hose		41	734-0797		Front Wheel—Rim Ass'y. Only	
11	1715-003		Gas Line		42	734-0298		Front Wheel—Tire Only—13.0 x 5.0-6	
12	736-0329		L-Wash. 1/4" Scr.*		43	61852		Mower Mtg.—Hitch Ass'y.	
13	710-0599		Hex Wash. Hd. Self Tapp Scr. 1/4-20 x .50"		44	712-0158		Hex Cent. L-Nut 5/16-18 Thd	
14	712-0130		Hex Ins. L-Nut 3/8-16 Thd.		45	714-0470		Cotter Pin 1/8" Dia. x 1.25" Lg.*	
15	736-0169		L-Wash. 3/8" Scr.*		46	1539-081		Hex Slotted Nut 3/4-10 Thd.	
16	61610		Steering Sector Arm Ass'y.		47	1541-006		L-Wash. 3/4" Scr.*	
17	41968		Steering Rod		48	710-0259		Hex Sems Scr. 5/16-18 x .62" Lg.*	
18	736-0169		L-Wash. 3/8" Scr.*		49	710-0118		Hex Scr. 5/16-18 x .75" Lg.*	
19	712-0116		Hex Ins. L-Nut 3/8-24 Thd.		50	710-0427		Hex Scr. 3/8-16 x 2.00" Lg.*	
20	1652-083		Pivot Bearing		51	736-0227		Fl-Wash. .390" I.D. x 1.50" O.D. x .134	
21	1509-122		Hex Scr. 3/4-10 x 4.00" Lg.		52	750-0245		Swing Arm Spacer	
22	22238		Collar and Arm (Casting)		53	42041		Bushing	
23	715-0101		Spring Pin Spiral 1/4" Dia. x 1.50" Lg.		54	42047		Rivet	
24	61601		Front Axle Ass'y.—L.H.		55	42041 61587		Gear Segment	
25	712-0116		Hex Ins. L-Nut 3/8-24 Thd.		56	22246		Pinion Gear	
26	736-0169		L-Wash. 3/8" Scr.*		57	715-0107		Spring Pin Spiral 5/16" Dia. x 1.38" Lg.	
27	22257		Pivot Bar Ass'y.		58	40562		Steering Tube Bushing	
28	61602		Front Axle Ass'y.—R.H.		59	736-0119		L-Wash. 5/16" Scr.*	
29	715-0246		Spring Pin Spiral 3/16" Dia. x 1.25" Lg.		60	712-0158		Hex Cent. L-Nut 5/16-18 Thd	
30	736-0288		Fl-Wash. .351" I.D. x 1.62" O.D. x .063		61	3132-149		Steering Post Ass'y. Comp.	
31	1652-084		Axle Brg. (Sintered)		62	22245		Steering Wheel Shaft	
32	723-0156		Ball Joint Ass'y. 3/8-24 Thd.		63	725-0530		Solenoid	

13875A-8
13885A-8

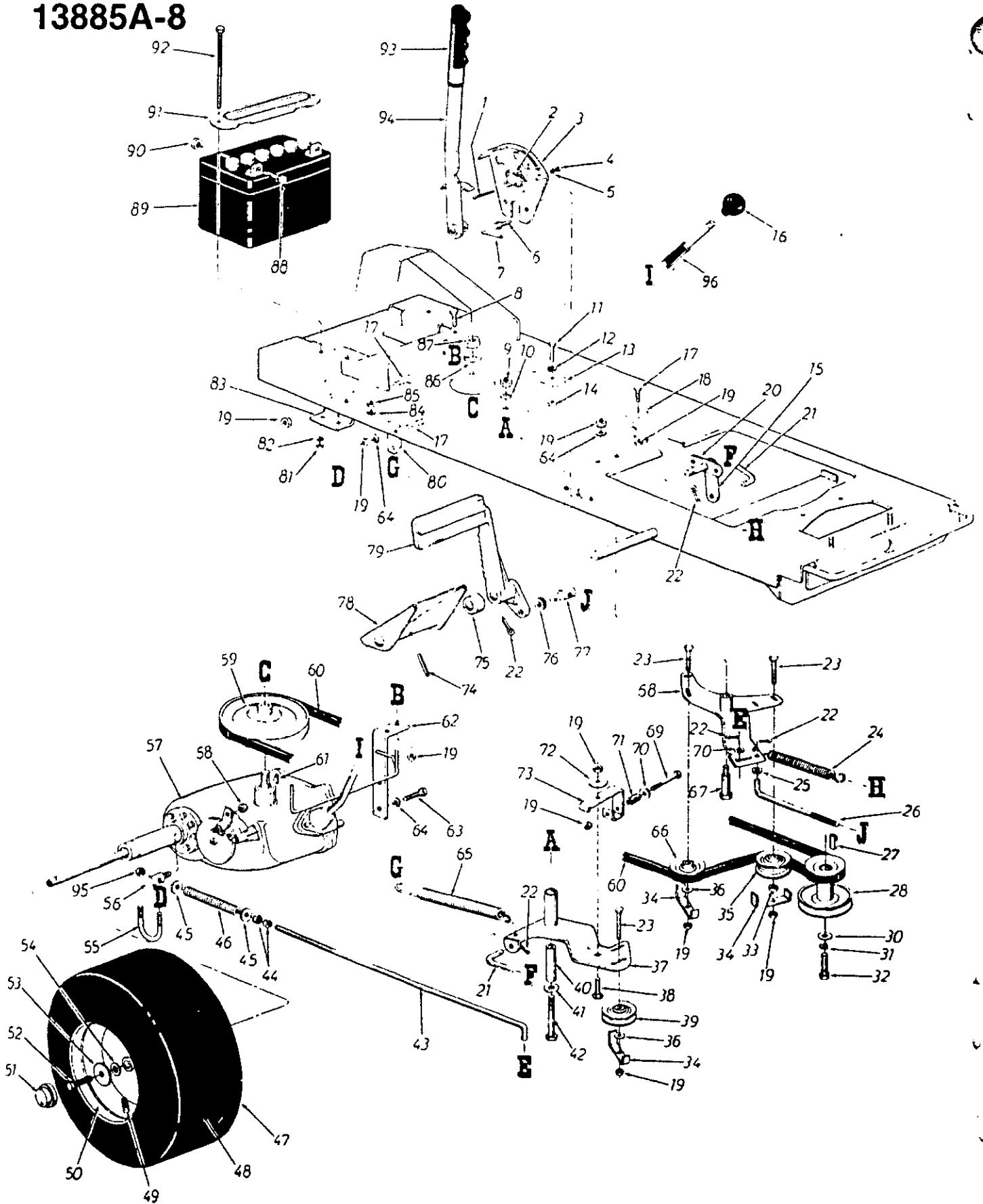

PARTS LIST FOR MODELS 13875A-8 AND 13885A-8

REF. NO.	PART NO.	COLOR CODE	DESCRIPTION	NEW PART	REF. NO.	PART NO.	COLOR CODE	DESCRIPTION	NEW PART
1	1501-029		Slotted Rd. Hd. Scr. #4-40 x .75" Lg.		48	734-0448		Rear Wheel—Tire Only 18.0 x 9.50	
2	725-0505		Safety Switch		49	734-0255		Air Valve	
3	3606-157		Lockout Plate		50	734-0764		Rear Wheel—Rim Ass'y. Only	
4	1538-035		Hex L-Nut #4-40 Thd.		51	41502		Hub Cap	
5	40891		FI-Wash. 1.62" O.D. x .781" I.D. x .062		52	710-0627		Hex Scr. 5/16-24 x .75" Lg.*	
6	710-0259		Hex Sems Scr. 5/16-18 x .62" Lg.*		53	736-0242		Belleville Wash. 5/16" I.D.	
7	715-0101		Spring Pin Spiral 1/4" Dia. x 1.50" Lg.*		54	736-0288		FI-Wash. .351" I.D. x 1.62" O.D. x .063	
8	710-0376		Hex Scr. 5/16-18 x 1.00" Lg.*		55	22247		"U"-Bolt	
9	712-0204		Hex Ins. L-Nut 1/2-13" Thd.*		56	711-0471		Ferrule	
10	736-0921		L-Wash. 1/2" Scr.*		57	—		Transaxle Comp. (See Page 28)	
11	710-0253		Hex Scr. 3/8-16 x 1.00" Lg.*		58	712-0158		Hex Cent. L-Nut 5/16-18 Thd.	
12	736-0258		FI-Wash. 3/8" I.D. x 1.00" O.D. x .127		59	756-0267		Transaxle Pulley	
13	1678-029		Mower Guide Yoke		60	754-0204		"V"-Belt 1/2" x 67" Lg.	
14	712-0130		Hex Ins. L-Nut 3/8-16 Thd.		61	714-0129		#4 Hi-Pro-Key 3/32" x 5/8" Dia.	
15	61598		Arm Ass'y.—Throw-Out Lever		62	61592		Torque Brkt. Ass'y.	
16	720-0175		Ball Knob 3/8-16 Thd.		63	710-0643		Hex Scr. 5/16-18 x 1.0" Lg. Spec.	
17	710-0118		Hex Scr. 5/16-18 x .75" Lg.*		64	736-0119		L-Wash. 5/16" Scr.*	
18	22396		Belt Guide		65	41977		Extension Spring	
19	712-0158		Hex Cent. L-Nut 5/16-18 Thd.		66	41027		"V"-Idler	
20	61599		Pivot Ass'y.—Throw-Out Lever		67	40118		Shoulder Bolt	
21	1683-088		Connecting Rod		68	2169-028		Idler Arm Ass'y. Comp.	
22	714-0115		Cotter Pin 1/8" Dia. x 1.00" Lg.*		69	710-0593		Hex Scr. 5/16-24 x 2.25" Lg.*	
23	710-0458		Carriage Bolt 5/16-18 x 1.75" Lg.*		70	736-0264		FI-Wash. .344" I.D. x .62" O.D. x .063	
24	1642-096		Extension Spring (Drive Idler)		71	1642-120		Compression Spring	
25	1543-058		Rubber Wash. .38" I.D. x .75" O.D. x .190		72	736-0258		FI-Wash. 3/8" I.D. x 1.00" O.D. x .127	
26	22337		Pedal Connecting Rod		73	1609-607		Engaging Brkt.—Blade Brake	
27	714-0114		Sq. Key 1/4 x 1/4 x 2.00" Lg.*		74	715-0108		Spring Pin Spiral 1/4" Dia. x 1.00" Lg.*	
28	756-0277		Engine Pulley Ass'y.	N	75	22269		Bushing Spacer	
30	736-0257		FI-Wash. .531" I.D. x 1.25" O.D. x .100		76	1543-058		Rubber Wash. .38" I.D. x .75" O.D. x .190	
31	736-0171		L-Wash. 7/16" Scr.*		77	22357		Adjustment Ferrule 3/8-16 Thd.	
32	710-0483		Hex Scr. 7/16-20 x 2.25" Lg.		78	61588		Toe Rest Ass'y.	
33	20142		FI-Wash. 1.0" O.D. x .692" I.D. x .24		79	3663-018		Pedal	
34	22545		Belt Guard Brkt.		80	1606-171		Spring Mounting Plate	
35	60799		Idler Pulley		81	712-0107		Hex Cent. L-Nut 1/4-20 Thd.	
36	736-0264		FI-Wash. .344" I.D. x .62" O.D. x .063		82	736-0264		FI-Wash. .344" I.D. x .62" O.D. x .063	
37	3169-026		Idler Arm Ass'y.—Deck Drive		83	2609-606		Transaxle Hanger Brkt.	
38	710-0451		Carriage Bolt 5/16-18 x .75" Lg.*		84	736-0169		L-Wash. 3/8" Scr.*	
39	42040		"V"-Idler		85	712-0798		Hex Nut 3/8-16 Thd.*	
40	1648-059		Idler Pivot Tube		86	736-0921		L-Wash. 1/2" Scr.*	
41	736-0192		FI-Wash. .531" I.D. x .93" O.D. x .090		87	712-0922		Hex Jam Nut 1/2-20 Thd.*	
42	1509-123		Hex Scr. 1/2-13 x 4.00" Lg.*		88	710-0377		Hex Sems Scr. 1/4-20 x .62" Lg.*	
43	747-0195		Brake Rod		89	725-0117		12 V—Battery	
44	712-0342		Hex Jam Nut 3/8-16 Thd.*		90	712-0107		Hex Cent. L-Nut 1/4-20 Thd.	
45	736-0185		FI-Wash. .406 I.D. x .749 O.D. x .063		91	08821		Battery Hold Down	
46	732-0324		Brake Spring		92	1509-124		Hex Scr. 1/4-20 x 5.50" Lg.*	
47	734-0760		Rear Wheel Ass'y.—Comp.		93	42384		Grip	
					94	2169-042		Throw-Out Lever Ass'y.	
					95	712-0181		Hex Top L-Nut 3/8-16 Thd.	
					96	42247		Shift Lever Sleeve	

13875A-8
13885A-8

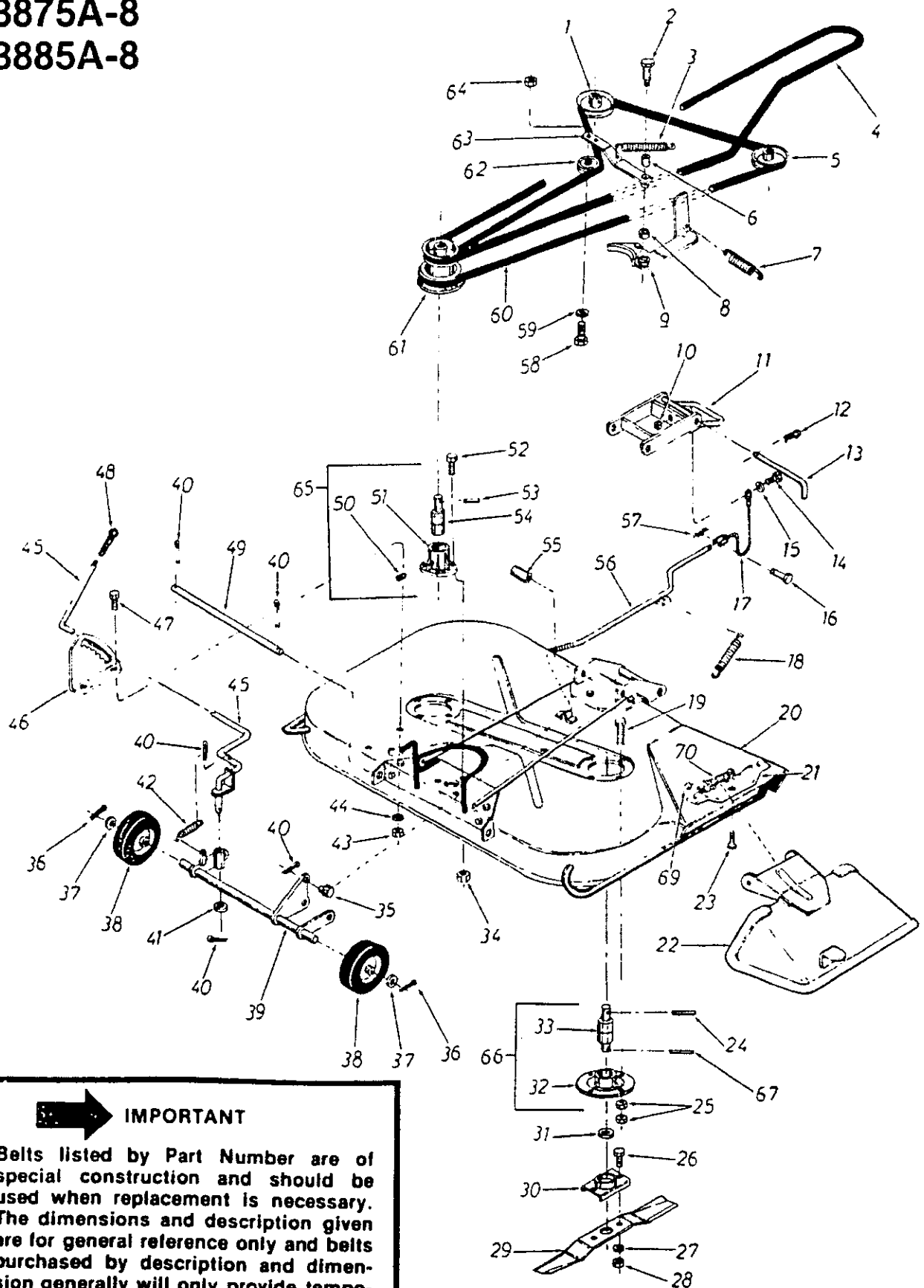

➔ IMPORTANT

Belts listed by Part Number are of special construction and should be used when replacement is necessary. The dimensions and description given are for general reference only and belts purchased by description and dimension generally will only provide temporary service.

PARTS LIST FOR MODELS 13875A-8 AND 13885A-8

REF. NO.	PART NO.	COLOR CODE	DESCRIPTION	NEW PART	REF. NO.	PART NO.	COLOR CODE	DESCRIPTION	NEW PART
1	2120-077		Blade Spindle Pulley		37	736-0256		FI-Wash. .635 I.D. x 1.00" O.D. x .03	
2	40118		Shoulder Bolt					Wheel—6 x 1.50—Deck	
3	41423		Extension Spring		38	42389		Axle Ass'y.—Deck	
4	754-0206		"V"-Belt 1/2 x 49.8" Lg. "A" Section		39	2123-038		Cotter Pin 1/8" Dia. x 1.00" Lg.*	
5	2120-077		Blade Spindle Pulley		40	714-0115		FI-Wash. 17/32 x 1-3/16 x 14 Ga.	
6	1652-141		Bearing		41	41485		Extension Spring	
7	1642-099		Extension Spring		42	41994		Hex Nut 3/8-16 Thd.*	
8	1657-081		Brake Lever Bushing		43	712-0798		L-Wash. 3/8" Scr. Heavy Duty	
9	3169-050		Blade Brake Lever Ass'y.		44	736-0217		Height Position Lever Ass'y.	
10	712-0158		Hex Cent. L-Nut 5/16-18 Thd.		45	22234		Height Position Brkt.	
11	61593		Mower Mtg. Hitch Ass'y.		46	22266		Hex Scr. 3/8-16 x .75" Lg.*	
12	714-0115		Cotter Pin 1/8" Dia. x 1.00" Lg.*		47	710-0216		Grip	
13	22256		Hitch Pin		48	720-0143		Axle Pivot Shaft	
14	710-0376		Hex Scr. 5/16-18 x 1.00" Lg.*		49	22260		Sq. Hd. Set Scr. 1/4-20 x .38" Lg. Cup	
15	736-0159		FI-Wash. .344 I.D. x .88 O.D. x .063		50	710-0329		Bearing Housing	
16	41468		Connecting Pin		51	717-0346		Hex Scr. 5/16-18 x 1.00" Lg.*	
17	41990		Cable Connector		52	710-0376		Spring Pin Spiral 5/16" Dia. x 1.38" Lg.	
18	41423		Extension Spring		53	715-0107		Bearing Spindle Ass'y.	
19	710-0118		Hex Scr. 5/16-18 x .75" Lg.*		54	22362		Spring Pin Roll 1/2" Dia. x 1.25" Lg.	
20	15174		36" Deck Ass'y.		55	42123		Connecting Rod Ass'y.	
21	11399		Adapter Plate Ass'y.		56	61607		Hair Pin	
22	11633		Chute Cover Ass'y. Comp.		57	40140		Hex Scr. 5/16-18 x 1.50" Lg.*	
23	710-0599		Hex Wash. S-Tapp Scr. 1/4-20 x .50" Lg.		58	710-0442		FI-Wash. .344 I.D. x .88 O.D. x .063	
24	715-0107		Spring Pin Spiral 5/16" Dia. x 1.38" Lg.		59	736-0159		"V"-Belt—4L	
25	712-0158		Hex Cent. L-Nut 5/16-18 Thd.		60	1651-066		Pulley Double—Drive Spindle	
26	710-0157		Hex Scr. 5/16-24 x .75" Lg.*		61	756-0266		Idler Pulley—Blade Belt	
27	736-0119		L-Wash. 5/16" Scr.		62	1626-104		Idler Arm Ass'y.	
28	712-0123		Hex Nut 5/16-24 Thd.*		63	1169-067		Hex Cent. L-Nut 5/16-18 Thd.	
29	3604-045		Blade		64	712-0158		Deck Spindle Ass'y.—Comp.	
30	41991		Blade Adapter		65	717-0347		Blade Spindle Ass'y.—Comp.	
31	1540-107		FI-Wash. 25/32 x 1-7/8 x 16 Ga.		66	61873		Spring Pin	
32	22364		Spindle Housing		67	42107		36" Deck Ass'y. Comp. (For Service Only)	
33	22361		Spindle Bearing Ass'y.		68	15173		Push Nut 1/4" Rod	
34	712-0158		Hex Cent. L-Nut 5/16-18 Thd.					Torsion Spring	
35	21989		Rod Adjustment Link		69	726-0106			
36	714-0115		Cotter Pin 1/8" Dia. x 1.00" Lg.*		70	732-0261			

*For faster service obtain standard nuts, bolts and washers locally. If these items cannot be obtained locally, order by part number and size as shown on parts list.

(497—Yard-Man Red) When ordering parts if color or finish is important, use color code shown at left. (e.g. Yard-Man Red Finish 15156 (497).)

The engine is not under warranty by the mower manufacturer. If repairs or service is needed on the engine, please contact your nearest authorized engine service outlet. Check the "Yellow Pages" of your telephone book under "Engines — Gasoline."



13875A-8
13885A-8

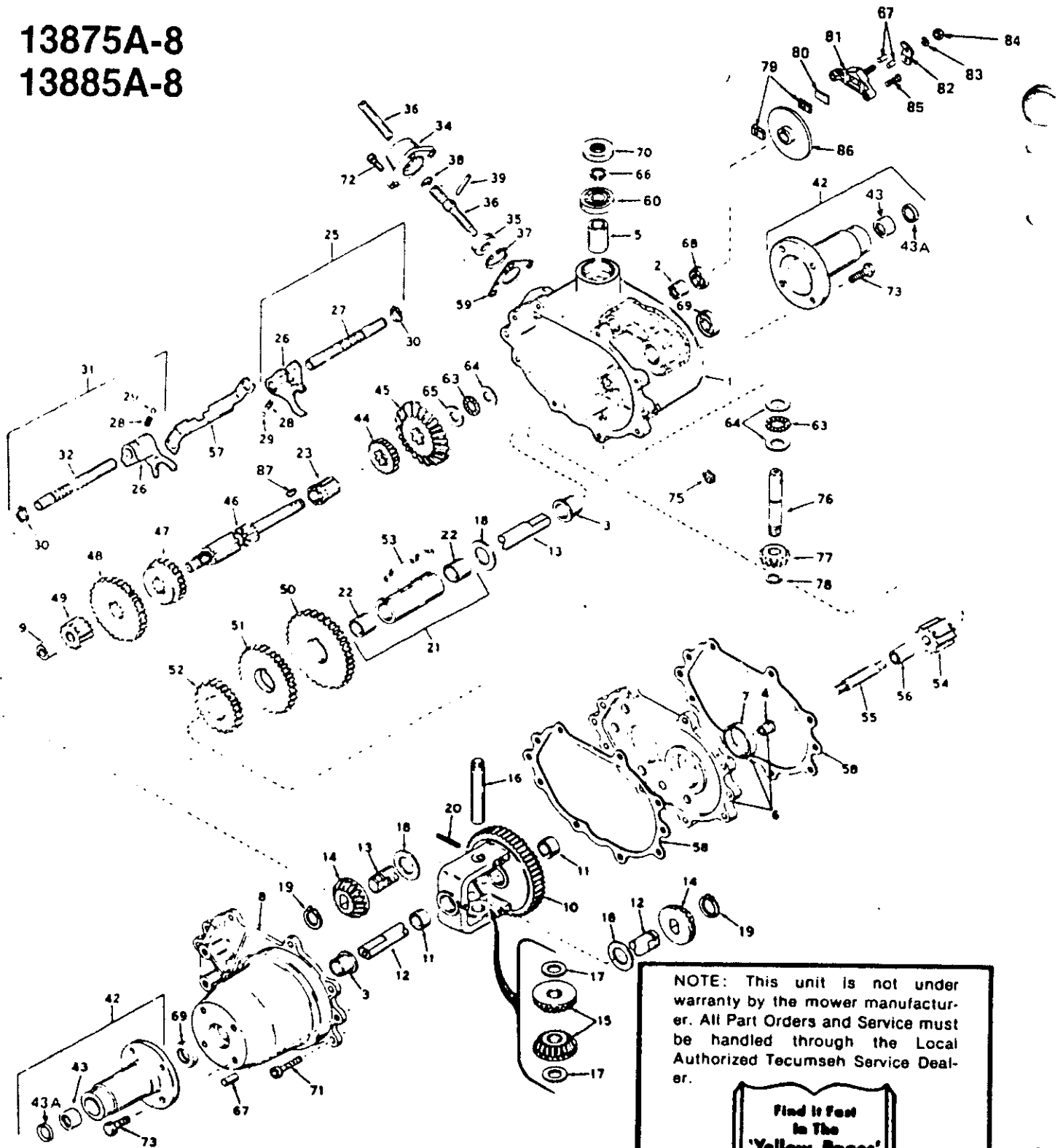

NOTE: This unit is not under warranty by the mower manufacturer. All Part Orders and Service must be handled through the Local Authorized Tecumseh Service Dealer.



PEERLESS MODEL 659

This unit is under warranty by Tecumseh Products Company. Parts and Service are available through all Tecumseh, Lauson Power Products Service Dealers. Check the "Yellow Pages" of your telephone directory under "Engines—Gasoline."

13875A-8 13885A-8

PARTS LIST FOR TRANSAXLE MODEL NO. 659

REF. NO.	PART NO.	DESCRIPTION	REF. NO.	PART NO.	DESCRIPTION
1	PE-770063	Case Ass'y., Transaxle (Incl. Nos. 2, 3 & 5)	43	PE-530105	Bearing, Needle
2	PE-780086	Bearing, Needle	43A	PE-788042	Seal, Oil
3	PE-780059	Bearing, Bronze	44	PE-778024A	Gear (16 teeth)
4	PE-780060	Bearing, Bronze	45	PE-778057	Gear, Bevel (33 teeth)
5	PE-780061	Bearing, Bronze	46	PE-776138	Shaft, Shifter and Brake
6	PE-786033	Plate Ass'y., Center (Incl. Nos. 4 and 7)	47	PE-778058	Gear, Shifting (2nd and 3rd)
7	PE-780062	Bearing, Bronze	48	PE-778059	Gear, Shifting (1st and Rev)
8	PE-772042	Cover Ass'y., Transaxle (Incl. Nos. 3 and 9)	49	PE-778060	Gear, Spur (12 teeth)
9	PE-780063	Bearing, Needle	50	PE-778061	Gear, Countershaft Drive (39 teeth)
10	PE-778053A	Gear Ass'y., Differential (Incl. No. 11)	51	PE-778062	Gear, Countershaft (34 teeth)
11	PE-780064	Bearing, Bronze	52	PE-778063	Gear, Countershaft (25 teeth)
12	PE-774353	Axle, Left Hand	53	PE-792034A	Key, Countershaft
13	PE-774354	Axle, Right Hand	54	PE-778064	Idler, Reverse
14	PE-778067	Gear, Bevel	55	PE-776057	Shaft, Reverse Idler
15	PE-778068	Pinion, Bevel	56	PE-786036	Spacer, Reverse Idler
16	PE-786034	Pin, Drive	57	PE-784087	Stop, Shifter
17	PE-780065	Washer, Thrust	58	PE-788033	Gasket, Case and Cover
18	PE-780001	Washer, Thrust	59	PE-788003	Gasket, Shift Lever Housing
19	PE-778038	Ring, Snap	60	PE-780093	Bearing, Ball
20	PE-792040	Pin, Roll	63	PE-780071	Bearing, Thrust
21	PE-786035	Sleeve Ass'y., Countershaft (Incl. No. 22)	64	PE-780072	Washer, Thrust
22	PE-780066	Bearing, Bronze	65	PE-780073	Washer, Thrust
23	PE-776090	Shaft, Idler	66	PE-792035	Ring, Snap
25	PE-784079	Rod Ass'y., Shift (1st and Rev.) (Incl. Nos. 26 thru 30)	67	PE-786026	Pin, Dowel
26	PE-784004	Fork, Shift	68	PE-788043	Seal, Oil
27	PE-784083	Rod, Shift	69	PE-788009	Seal, Oil
28	PE-792003	Spring	70	PE-788035	Seal, Oil
29	PE-792004	Ball, Steel	71	PE-792036	Screw, Flanged Hex Hd., 1/4-20 x 1 1/4
30	PE-792017	Ring, Snap	72	PE-792007	Screw, Flanged Hex Hd., 1/4-20 x 3/4
31	PE-784084	Rod Ass'y., Shift (2nd and 3rd) (Incl. Nos. 26, 28, 29, 30 and 32)	73	PE-792037	Screw, Hex Hd. Sems, 5/16-18 x 1
32	PE-784085	Rod, Shift	75	PE-792039	Plug, Pipe, 1/8"
34	PE-784088	Housing, Shift Lever	76	PE-776155	Shaft, Input
35	PE-784094	Keeper, Shift Lever	77	PE-778077	Pinion, Input
36	PE-784286	Lever, Shift	78	PE-788040	Ring, Retaining
37	PE-792016	Ring, Snap	79	PE-790006	Pad, Brake
38	PE-792001	Ring, Quad	80	PE-790007	Plate, Brake Pad
39	PE-792049	Pin, Drive	81	PE-790005	Holder, Brake Pad
42	PE-782049	Housing Ass'y., Axle (Incl Nos. 43 and 43A)	82	PE-790008	Lever, Brake
			83	PE-792076	Washer, Flat
			84	PE-792075	Nut, Lock
			85	PE-792073	Screw, Hex Washer Hd. Taptite, 1/4-20 x 1 1/4
			86	PE-790009	Disk, Brake
			87	PE-792045	Key, Woodruff #61



NOTE

The no. 780091 bearing and seal can be used interchangeably with the separate #530105 bearing and the separate no. 788042 seal.

13875A-8
13885A-8

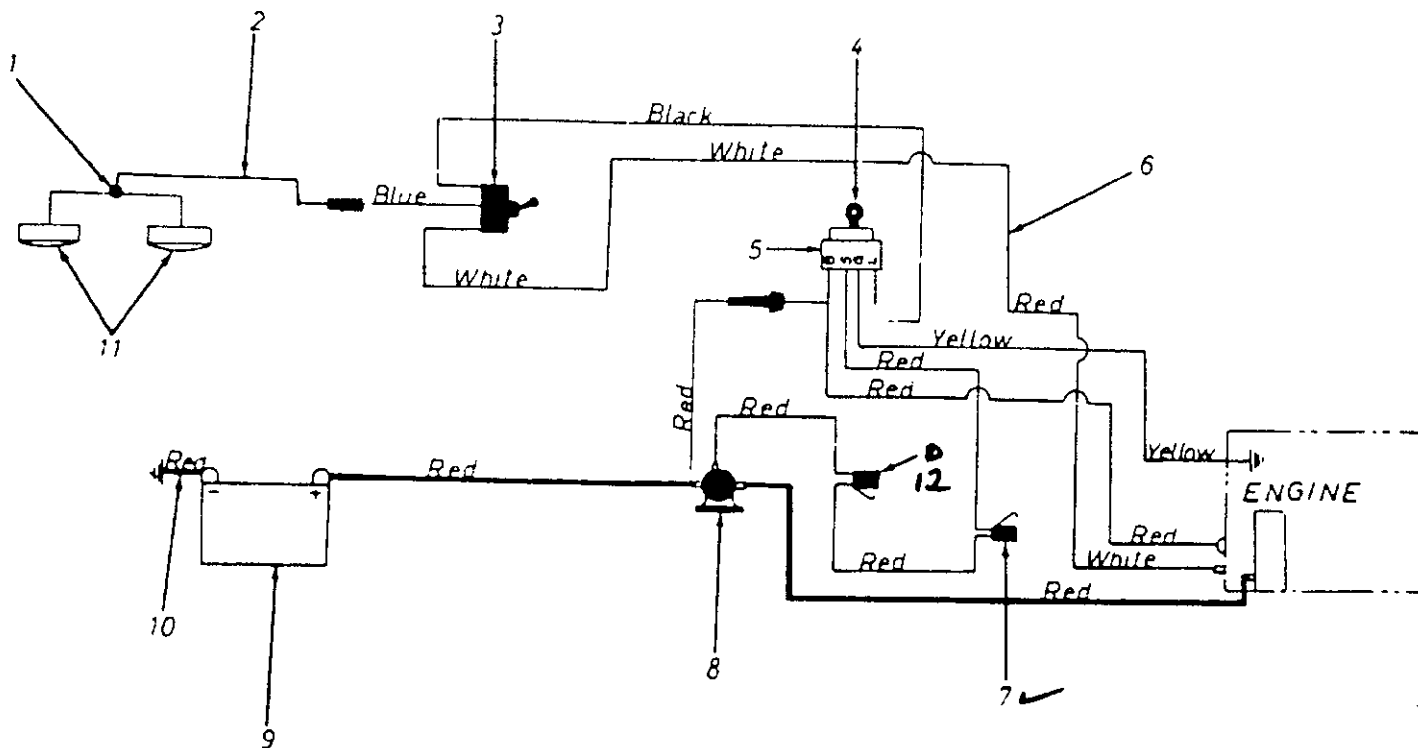

PARTS LIST FOR MODELS 13875A-8 AND 13885A-8

REF. NO.	PART NO.	COLOR CODE	DESCRIPTION	NEW PART
1	1160-017		Connector	
2	1188-02		Electric Wire	
3	725-0506		Light Switch (Toggle)	
4	725-0201		Ignition Key	
5	725-0267		Ignition Switch	
6	725-050631		Wire Harness	N
7	725-0505		Safety Switch—N.C.	
8	725-0530		Solenoid	
9	725-0117		12 Volt Battery	
10	1188-018		Electric Wire	
11	1744-002		Headlights	
	1744-003		Bulb	
	1653-024		Gasket	
	1743-006		Lens	
12	725-0277		SAFETY SWITCH—N.C.	

YARD-MAN PARTS INFORMATION

POWER EQUIPMENT PARTS AND SERVICE

Parts and service for all YARD-MAN manufactured power equipment are available through the authorized service distributors listed below. All orders should specify the model number of your unit, parts numbers, description of parts and the quantity of each part required. **DO NOT SEND PARTS ORDER TO FACTORY.** Contact distributor for name of local dealer.

ALABAMA	DOTHAN	
Auto Elect. Co of Ala Inc	1301 Montgomery Hwy	36301
	DECATUR	
Alabama Farmers Co-op Inc.	121 Somerville Road	35601
	FLORENCE	
B M. Ingram Inc	705 S Seminary	35630
ARKANSAS	LITTLE ROCK	
Frank Lyon Company	65th and Scott Hamilton	72204
CALIFORNIA	SACRAMENTO	
Bliss Power Lawn Equip Co.	101 Commerce Circle	95815
	SAN BERNARDINO	
Lawnmower Supply Co	25608 E. Baseline	95926
	ORANGE	
Pearson's Lawn Mower	169 S Hewel St	92669
COLORADO	WHEAT RIDGE	
Turf Equipment and Parts	8035 West 44th St.	80033
FLORIDA	CORAL GABLES, MIAMI	
Moz-All of Florida, Inc	365 Greco	33146
	JACKSONVILLE	
Radco Dist., Inc	2403 Market St.	32206
GEORGIA	TIFTON	
Thigpen Dist. Co	Rebel Road	31794
ILLINOIS	CERRO GORDO	
Van Horn Sales	R R #1	61818
	LYONS	
Keen Edge	8615 Ogden Ave	60534
	MORTON GROVE	
V-G Supply Co	8701 North Lincoln	60053
	SULLIVAN	
Lawn Equip. Service Co	1133 W Jackson St	61951
INDIANA	EVANSVILLE	
Midwest Equip. & Supply	901 Keok	47711
	FORT WAYNE	
Lynn Koehlinger Co	3675 North Wells-Box 96	46801
KANSAS	LENEXA	
Frank Lyon Co	Old Sante Fe & 101st	66215
KENTUCKY	HEBRON	
J A Stevens Mower Co	P O Box 38	41048
	HOPKINSVILLE	
Cayco Mill Supply Co	505 East First St.	42240
MAINE	BANGOR	
M L Coffin Co	725 Broadway	04401
MASSACHUSETTS	SOUTHBORO	
Crandall-Hicks Co	Rt #9	01772
MICHIGAN	FERNDALE	
Ideal Mower Sales, Inc.	811 Woodward Heights	48220
	GRAND RAPIDS	
Jac Van Dist., Inc	4477 E. Paris, S.E.	49508
	JACKSON	
Factory Branch	440 East Prospect	49202
MINNESOTA	MINNEAPOLIS	
Westgo Dist Inc	14508 21st Ave North	55440
MISSOURI	ROLLA	
Ozark Equip. Co., Inc	Hwy. 63 & Black St -Box 784	65401

BRIGGS & STRATTON, TECUMSEH AND PEERLESS PARTS AND SERVICE

Briggs & Stratton, Tecumseh and Peerless parts and service should be handled by your nearest authorized engine service firm. Check the yellow pages of your telephone directory under the listing **Engines—Gasoline**, Briggs & Stratton or Tecumseh Lauson.

	SPRINGFIELD	
Frank Lyon Co.	3055 E. Division	65802
MONTANA	BILLINGS	
Parker Montana Co.	2100 Sixth Ave North	59101
NEBRASKA	OMAHA	
K & K Co. Inc.	711 S. 15th St.	68102
NEW JERSEY	PARSIPPANY	
Elmco Dist., Inc.	2 Eastmans Rd.	07054
NEW YORK	SYRACUSE	
Morris Electronics Dist Inc	1153 W. Fayette St.	13201
NORTH CAROLINA	WINSTON-SALEM	
Carswell Dist., Co	3750 N. Liberty St.-Box 4193 North Station	27105
OHIO	CLEVELAND	
Tecca Dist. Co.	4747 Manufacturing Ave.	44135
OKLAHOMA	ADA	
Ada Auto Supply	Box 338-301 E. 12th St	74820
	OKLAHOMA CITY	
Moore Cycle & Supply	1537 W. Main St	73106
PENNSYLVANIA	HATFIELD	
Ronconi Equip. Inc	2967 Sandstone Dr	19440
TENNESSEE	BRISTOL	
Mitchell-Powers Hardware Co	5th St. Extension	37623
	KNOXVILLE	
House Haddon Hdwe	757 Western Ave	37917
Master Repair Service	2423 Broadway, N E	37917
	UNION CITY	
Graves Dist. Co., Inc	1318 Stad Ave	38261
TEXAS	COMANCHE	
Higginbotham Bros	203 W. Central & Mary	76442
	FORT WORTH	
Woodson Sales Corp	1702 N. Sylvania	76111
	HOUSTON	
Outdoor Equip., Inc.	8000 Harwin St.-Box 42146	77036
UTAH	SALT LAKE CITY	
Boyd Martin Co	1260 N. W. Temple	84116
	BOUNTIFUL	
Powered Products	485 N. 500 W	84010
VIRGINIA	BLUEFIELD	
Bluefield Supply Co.	Box 269-Mercer St	24701
	LORTON	
Ronconi Equip. Inc.	8815 Telegraph Rd.	22079
	LYNCHBURG	
Bailey-Spencer Hardware Co.	1016-26 Commerce St	24505
	RICHMOND	
Universal Tractor Equip. Corp.	Box 5489 928 N. Meadow St.	23220
WASHINGTON	SEATTLE	
Equipment North West Inc.	1410 Fourteenth Ave.	98122
WISCONSIN	CHILTON	
Horst Dist. Co., Inc.	444 N. Madison St.	53014
CANADA	KITCHENER, ONTARIO	
MTD Products	97 Kent Ave.	N2G4J1

WARRANTY PARTS AND SERVICE POLICY

The purpose of warranty is to protect the customer from defects in workmanship and materials, defects which are NOT detected at the time of manufacture. It does not provide for the unlimited and unrestricted replacement of parts. Use and maintenance are the responsibility of the customer. The manufacturer cannot assume responsibility for conditions over which it has no control. Simply put, if it's the manufacturer's fault, it's the manufacturer's responsibility; if it's the customer's fault, it's the customer's responsibility.

CLAIMS AGAINST THE MANUFACTURER'S WARRANTY INCLUDES

1. Replacement of Missing Parts on new equipment.
2. Replacement of Defective Parts within the warranty period.
3. Repair of Defects within the warranty period.

All claims MUST be substantiated with the following information:

1. Model Number of unit involved.
2. Date unit was purchased or first put into service.
3. Date of failure—Date Repaired.
4. Nature of failure—Correction.



.

.



.

