

OWNERS MANUAL

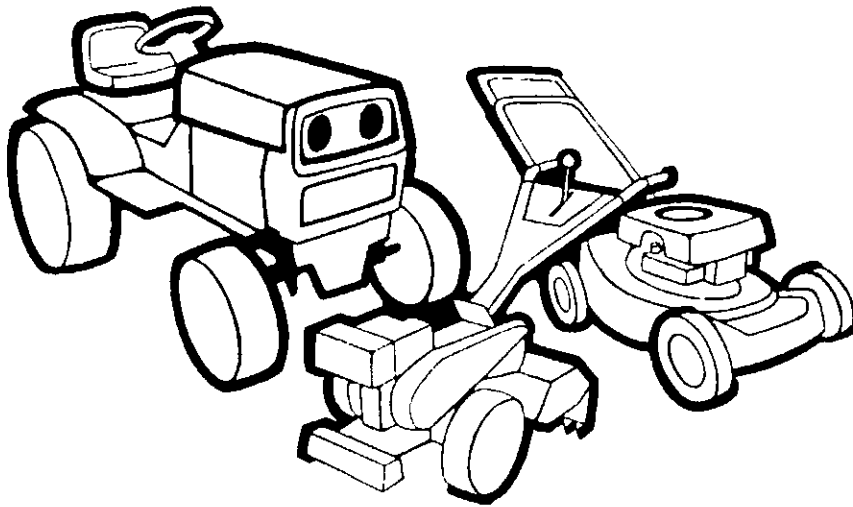

YaRD-MaN

**5-SPEED
TRANSAXLE
LAWN
TRACTOR**

**ASSEMBLY
OPERATION
MAINTENANCE
PARTS LIST**

**Model Number
13618SP**

**Important:
Read Safety Rules and
Instructions Carefully**

Thank you for purchasing an
American built product.

INDEX

Safe Operation Practices	3	Off-Season Storage	17
Assembly Instructions	4	Trouble Shooting Chart	18, 19
Controls	9	Illustrated Parts for Rider	20, 22, 24, 26
Operation	11	Parts List for Rider	21, 23, 25, 27
Adjustments	12	Illustrated Parts for Transaxle	28, 29
Lubrication	13	Electrical System	30
Maintenance	14	Parts Information	Back Cover

LIMITED WARRANTY

For two years from the date of original retail purchase, YARD-MAN COMPANY will either repair or replace, at its option, free of charge, F.O.B. factory or authorized service firm, any part or parts found to be defective in material or workmanship. Transportation charges for the movement of any power equipment unit or attachment are the responsibility of the purchaser. Transportation charges for any parts submitted for replacement under this warranty must be paid by the purchaser unless such return is requested by YARD-MAN COMPANY.

This warranty will not apply to any part which has become inoperative due to misuse, excessive use, accident, neglect, improper maintenance, alterations, or unless the unit has been operated and maintained in accordance with the instructions furnished. This warranty does not apply to the engine, Peerless components, the motor, battery, battery charger or component parts thereof. Please refer to the applicable manufacturer's warranty on these items.

Warranty on units used commercially is limited to sixty (60) days.

Warranty service is available through your local authorized service dealer or distributor. If you do not know the dealer or distributor in your area, please write to the Customer Service Department of YARD-MAN.

The return of a complete unit will not be accepted by the factory unless prior written permission has been extended by YARD-MAN.

This warranty gives you specific legal rights. You may also have other rights which vary from state to state.



This unit is equipped with an internal combustion engine and should not be used on or near any unimproved forest-covered, brush-covered or grass-covered land unless the engine's exhaust system is equipped with a spark arrester meeting applicable local or state laws (if any). If a spark arrester is used, it should be maintained in effective working order by the operator.

In the State of California the above is required by law (Section 4442 of the California Public Resources Code). Other states may have similar laws. Federal laws apply on federal lands. A spark arrester muffler is available at your nearest engine authorized service center.



WARNING

To reduce the potential for any injury, comply with the following safety instructions. Failure to comply with the instructions may result in personal injury.

SAFE OPERATION PRACTICES FOR RIDING VEHICLES

1. Read this owner's manual carefully in its entirety before attempting to assemble or operate this unit. Keep this manual in a safe place for future and regular reference and for ordering replacement parts.
2. This unit is a precision piece of power equipment, not a plaything. Therefore exercise extreme caution at all times.
3. Know the controls and how to stop quickly—**READ THIS OWNER'S MANUAL.**
4. Do not allow children to operate vehicle. Do not allow adults to operate it without proper instruction. Only persons well acquainted with these rules of safe operation should be allowed to use your mower.
5. No one should operate this unit while intoxicated or while taking medication that impairs the senses or reactions.
6. Wear sturdy, rough-soled work shoes and close-fitting slacks and shirts to avoid entanglement in the moving parts. Never operate a unit in bare feet, sandals, or sneakers.
7. To prevent injury, do not carry passengers or give rides. Keep children, pets and bystanders out of the area while mowing. Only the operator should ride on the unit and only ride in the seat.
8. Check overhead clearance carefully before driving under power lines, guy wires, bridges or low hanging tree branches, before entering or leaving buildings, or in any other situation where the operator may be struck or pulled from the unit, which could result in serious injury.
9. To maintain control of the unit and reduce the possibility of upset or collision, operate the tractor smoothly. Avoid erratic operation and excessive speed.
10. Keep the area of operation clear of all persons, particularly small children and pets. Stop engine when they are in the vicinity of your mower. Although the area of operation should be completely cleared of foreign objects, a small object may have been overlooked and could be accidentally thrown by the mower in any direction and cause injury.
11. Clear work area of objects which might be picked up and thrown by the mower in any direction and cause injury.
12. Stop the blade(s) when crossing gravel drives, walks or roads.
13. Disengage all attachment clutches and shift into neutral before attempting to start engine.
14. Disengage power to attachment(s) and stop engine before leaving operating position.
15. Do not put hands or feet near or under rotating parts. Keep clear of the discharge opening at all times as the rotating blade(s) can cause injury.
16. Disengage power to attachment(s) and stop engine before making any repairs or adjustments. Disconnect the spark plug wire and keep the wire away from the plug to prevent accidental starting.
17. Before attempting to unclog the mower or discharge chute, stop the engine. The mower blade(s) may continue to rotate for a few seconds after the engine is shut off. Therefore, be sure the blade(s) have stopped completely. Disconnect the spark plug wire and keep the wire away from the plug to prevent accidental starting.
18. Disengage power to attachment(s) when transporting or not in use.
19. Take all possible precautions when leaving vehicle unattended such as disengaging power-take-off, lowering attachments, shifting into neutral, setting parking brake, stopping engine and removing key.
20. Do not stop or start suddenly when going uphill or downhill. Mow up and down face of steep slopes; never across the face. Use extreme caution if it is necessary to drive the tractor up an incline or back the tractor down an incline because the front of the tractor could lift and rapidly flip over backward which could cause serious injury.
21. Reduce speed on slopes and in sharp turns to prevent tipping or loss of control. Always keep the tractor in gear when going down steep hills to take advantage of engine braking action.
22. Stay alert for holes in terrain and other hidden hazards.
23. Use care when pulling loads or using heavy equipment.
 - A. Use only approved drawbar hitch points.
 - B. Limit loads to those you can safely control.
 - C. Do not turn sharply. Use care when backing.
 - D. Use counterweight(s) or wheel weights when suggested in owner's manual.
24. Watch out for traffic when crossing or near roadways.
25. When using any attachments, never direct discharge of material toward bystanders nor allow anyone near vehicle while in operation.
26. Handle gasoline with care. It is highly flammable.
 - A. Use approved gasoline container.
 - B. Never remove cap or add gasoline to a running or hot engine or fill fuel tank indoors. Wipe up spilled gasoline.
 - C. Open doors if engine is run in garage. Exhaust fumes are dangerous. Do not run engine indoors.

27. Keep the vehicle and attachments in good operating condition, and keep safety devices in place. Use guards as instructed in operator's manual.
28. Keep all nuts, bolts, and screws tight to be sure the equipment is in safe working condition.
29. Never store the equipment with gasoline in the tank inside a building where fumes may reach an open flame or spark. Allow engine to cool before storing in any enclosure.
30. To reduce fire hazard, keep engine free of grass, leaves or excessive grease.
31. The vehicle and attachments should be stopped and inspected for damage after striking a foreign object. The damage should be repaired before restarting and operating the equipment.
32. Do not change the engine governor settings or overspeed the engine.
33. When using the vehicle with mower, proceed as follows:
 - (1) Mow only in daylight or in good artificial light.
- (2) Never make a cutting height adjustment while engine is running if operator must dismount to do so.
- (3) Shut the engine off and wait until the blade comes to a complete stop before removing the grass catcher.
- (4) Check blade mounting bolts for proper tightness at frequent intervals.
34. Check grass catcher bags frequently for wear or deterioration. For safety protection, replace only with new bag meeting original equipment specifications.
35. Look behind to make sure the area is clear before placing the transmission in reverse and continue looking behind while backing up. Disengage blades before shifting into reverse and backing up.
36. This unit should not be driven up a ramp onto a trailer or truck under power, because the unit could tip over, causing serious personal injury. The unit must be pushed manually to load properly.

ASSEMBLY



NOTE

This unit is shipped **WITHOUT GASOLINE** or **OIL**. After assembly, see separate engine manual for proper fuel and engine oil recommendations.

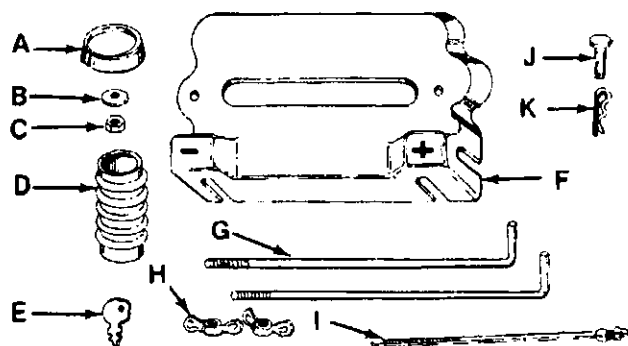

FIGURE 1.



NOTE

Reference to right hand or left hand side of machine is from the driver's seat facing forward.

Contents of Hardware Pack: (See Figure 1)

- A (1) Steering Wheel Cap
- B (1) Belleville Washer
- C (1) Hex Nut 5/16-18 Thread
- D (1) Steering Bellow
- E (2) Ignition Keys
- F (1) Battery Cover
- G (2) Battery Hold-Down Rods
- H (2) Wing Nuts
- I (1) Cable Tie
- J (1) Clevis Pin
- K (1) Hairpin Cotter
- (2) Hex Bolts and Lock Washers (Not Shown)

Loose Parts in Carton:

- (1) Battery Pack
- (1) Steering Wheel
- (1) Seat

BATTERY INFORMATION



- A. Battery acid must be handled with great care as contact with it can burn and blister the skin. It is also advisable to wear protective clothing (goggles, rubber gloves and apron) when working with it.*
- B. Should battery acid accidentally splatter into the eyes or onto the face, rinse the affected area immediately with clean cold water. If there is any further discomfort, seek prompt medical attention.
- C. If acid spills on clothing, first dilute it with clean water, then neutralize with a solution of ammonia/water or baking soda/water.

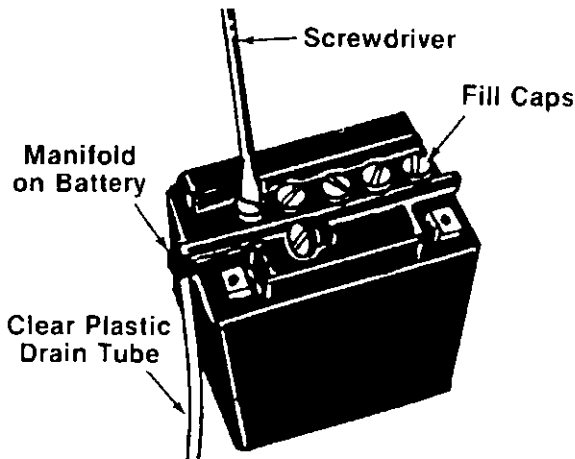

FIGURE 2.

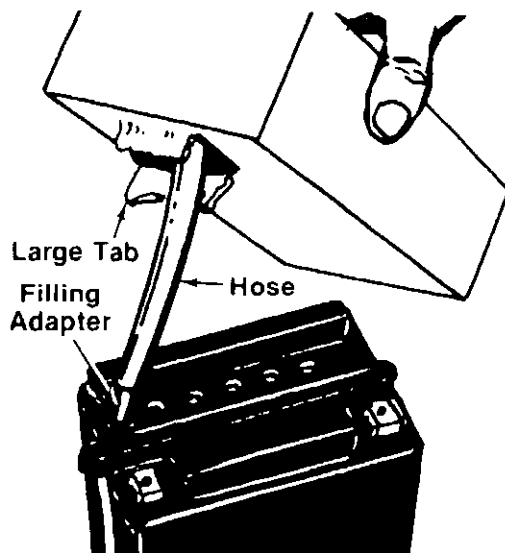

FIGURE 3.

- D. Since battery acid is corrosive, do not pour it into any sink or drain. Before discarding empty electrolyte containers, rinse them with a neutralizing solution.
- E. NEVER connect or disconnect charger clips to battery while charger is turned on as it can cause sparks.
- F. Keep all lighted materials (cigarettes, matches, lighters) away from the battery as the hydrogen gas generated during charging can be combustible.
- G. As a further precaution, only charge the battery in a well-ventilated area.

***Always shield eyes, protect skin and clothing when working near batteries.**

ACTIVATING AND INSTALLING THE BATTERY

1. Upon opening the battery pack, you should receive acid pack, battery, drain tube, filling adapter and hardware.



BATTERIES CONTAIN SULFURIC ACID AND MAY CONTAIN EXPLOSIVE GASES (when electrolyte has been added).

2. Place the battery on table or workbench to be filled.
- ← 3. Place one end of clear plastic drain tube on manifold of battery. See figure 2.



Some batteries may already have the drain tube installed, in which case it may be necessary to snip off the sealed end.

4. Remove the six fill caps from the top of the battery with a screwdriver. Care should be taken not to damage the fill caps. See figure 2.
5. Lay acid package down, with "push in" facing up. Using thumb, push in small perforated tab at dot on front of package. Tear down large tab to solid line, exposing hose. **Do not** use any sharp object to open acid package.
6. Pull out hose from package and hold upright. Squeeze hose forcing all acid back into package. Cut off tip of hose and insert filling adapter. See figure 3.
- ← 7. Fill each cell to upper level marked on front of battery. Replace fill caps on battery. See figure 3.



DANGER

Battery contains sulfuric acid. Refer to warning on page 5. Antidote: EXTERNAL—Flush with water. INTERNAL—Drink large quantities of water or milk. Follow with milk of magnesia, beaten egg or vegetable oil. Seek prompt medical attention. EYES: Flush with cool water for at least 15 minutes, then seek immediate medical attention.

Since batteries produce explosive gases, keep all lighted materials (cigarettes, lighters, matches, etc.) away. Be sure to charge battery only in well-ventilated areas.

**KEEP BATTERIES
OUT OF THE REACH OF CHILDREN!**

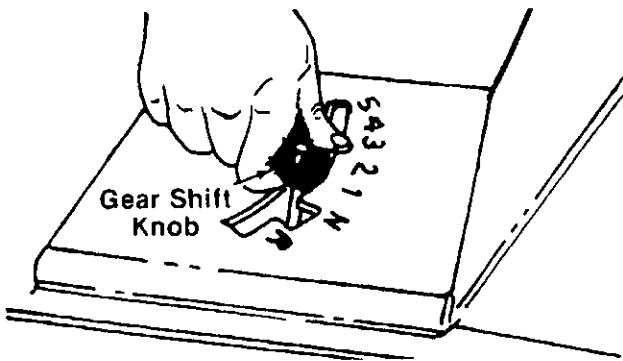

FIGURE 4.

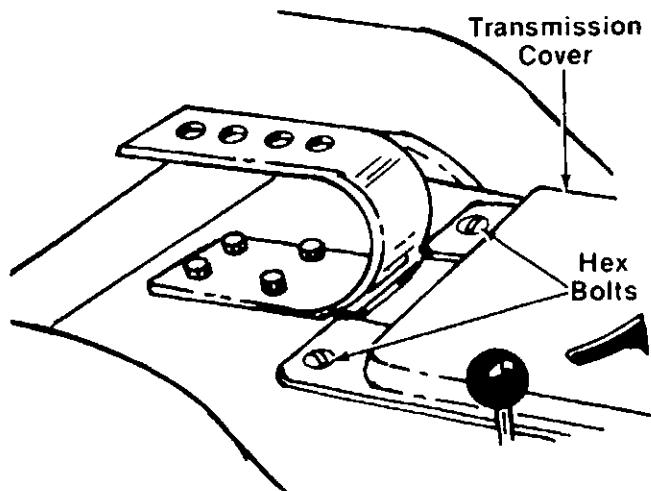

FIGURE 5.

8. Allow battery to sit for 20 to 30 minutes. Add additional acid, if necessary, to bring it up to the proper level.
9. The battery can be charged after the 20 minutes sitting period. **SLOW CHARGE THE BATTERY (DO NOT FAST CHARGE)** at a maximum bench rate of 1.4 amperes until the specific gravity reading is 1.260-1.280. Charge for a minimum of 2 hours and a maximum of 8 hours.

NOTE

Charging rate after battery has been put into operation: The battery is to be charged for a period of 14-16 hours. **NO LONGER THAN 30 HOURS.**

CAUTION

After battery has been in service, add only distilled water. **DO NOT ADD ACID.**

NOTE

This engine is equipped with an alternator. The current for the battery charger alternator is unregulated. During normal operation, it is only necessary to charge the battery:

1. When it is activated for the first time.
2. Before winter storage.
3. Before using the lawn tractor after winter storage.

← INSTALLING THE BATTERY

1. Place gear shift lever in the "neutral" position. Unscrew the gear shift knob. See figure 4.

2. Remove the two hex bolts which secure the transmission cover. See figure 5.

NOTE

The transmission cover on your unit may be secured with ¼ turn studs. Push down and turn the studs one-quarter turn to remove the cover.

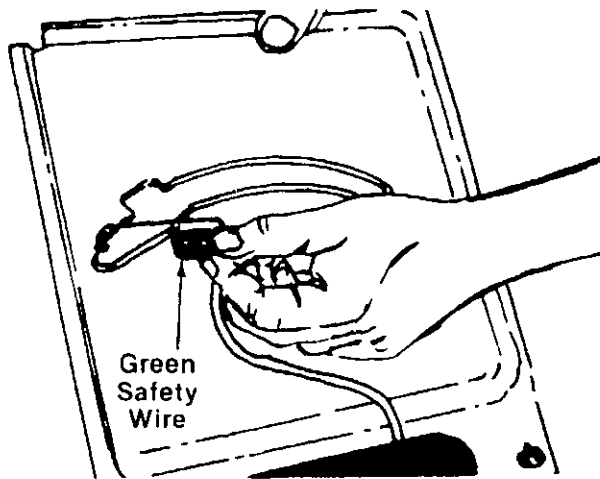

FIGURE 6.

3. Lift the transmission cover. Unplug the green safety wire from beneath the transmission cover. See figure 6. Remove transmission cover.

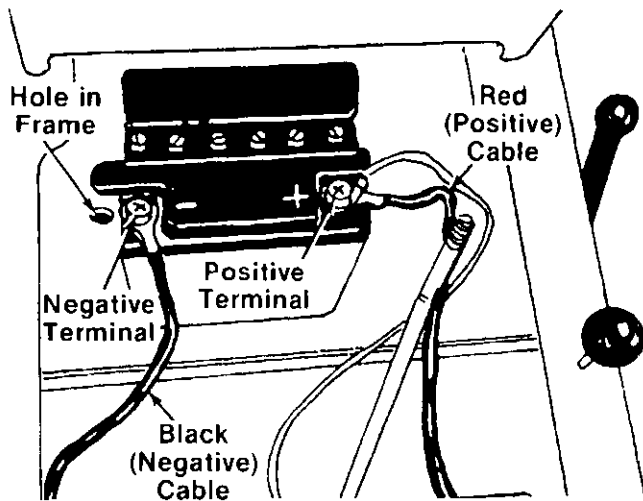

FIGURE 7.

4. Place the battery in the lawn tractor so that the positive terminal is facing the right side of the unit. See figure 7.

NOTE

Right and left hand sides of the unit are determined from the operating position, facing forward.

5. Slide the square nut (provided with battery hardware) into the positive (+) terminal. Place the positive (heavy red wire) cable and the small red wire on the positive terminal. Secure with screw and lock washer provided. See figure 7.
6. Slide the square nut (provided with battery hardware) into the negative (-) terminal. Place the negative (heavy black wire) cable on the negative terminal. Secure with screw and lock washer provided.

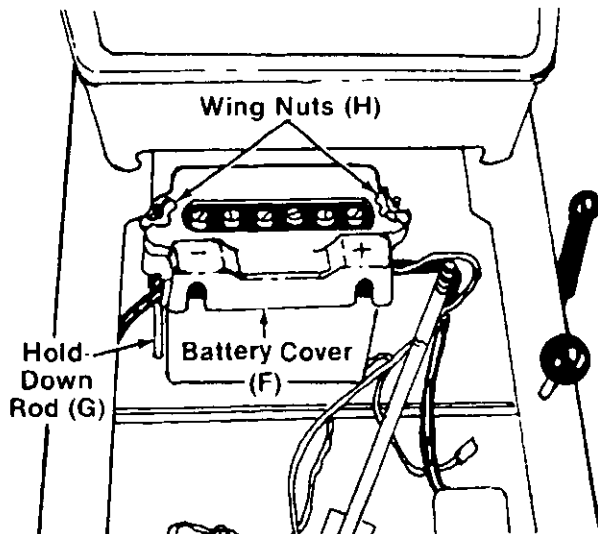

FIGURE 8.

7. Hook one hold-down rod (G) into the hole in the frame beside the battery. See figure 7. Place the battery cover (F) in position over the hold-down rod. Secure with wing nut (H). Attach other hold-down rod to the other side of battery cover in the same manner. See figure 8.

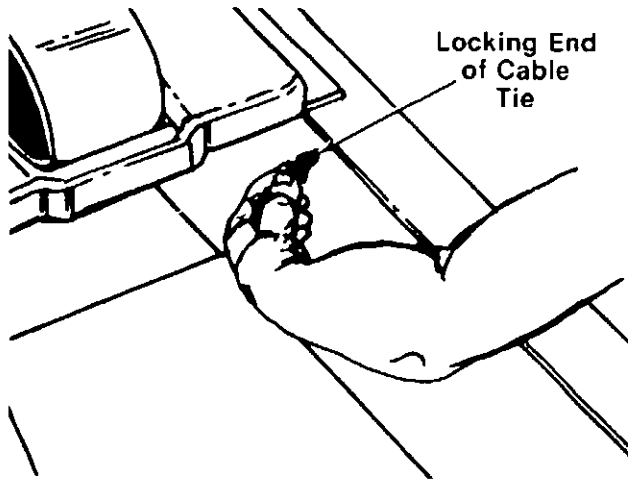

FIGURE 9.

8. Push the locking end of cable tie (I) through the hole in the left frame as shown in figure 9. Route the battery drain tube back to the cable tie. Place end of cable tie through the slot so a loop is formed around the drain tube to secure it. Tighten cable tie and cut off excess end.
9. Plug the green safety wire into the switch beneath the transmission cover. Refer to figure 6. Replace the transmission cover and gear shift knob.

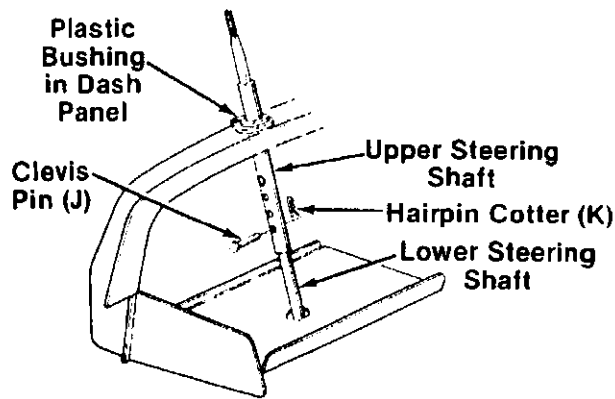

FIGURE 10.—Model 698 Shown

STEERING WHEEL INSTALLATION

1. For shipping purposes, the upper steering shaft is pushed all the way down over the lower steering shaft. Pull the upper steering shaft up. The four holes in the shaft provide four steering wheel heights. Select desired hole and secure with clevis pin (J) and hairpin cotter (K). See figure 10.

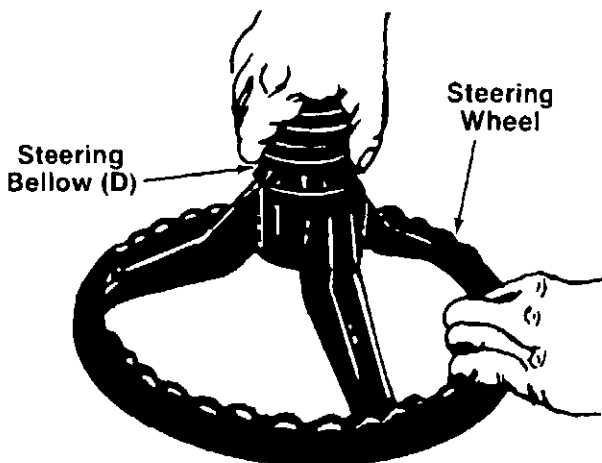
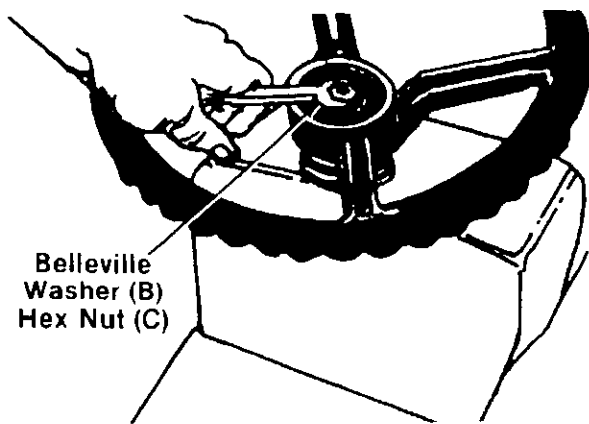

FIGURE 11.

2. Attach steering bellow (D) to the steering wheel as shown in figure 11.

NOTE

One end of the steering bellow is slightly larger than the other. The larger end must be assembled to the steering wheel.



3. Place steering wheel and bellow on the steering shaft, lining up the flats in the wheel with the flats on the shaft.
4. Secure with belleville washer (B) (cupped side against the steering wheel) and hex nut (C). See figure 12.
5. Press the steering wheel cap (A) on the steering wheel by hand.

FIGURE 12.

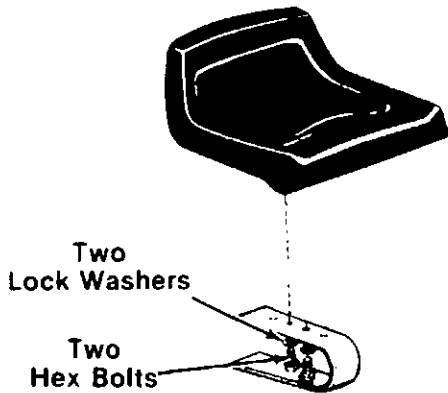

- SEAT INSTALLATION**
- The seat may be adjusted to three different positions. Select desired position and secure to seat spring with two hex bolts and lock washers. See figure 13.

FIGURE 13.

CONTROLS

THROTTLE CONTROL

The throttle control is used to regulate the engine speed and to activate the choke on the engine. To get maximum efficiency from cutting, the throttle should be in the FAST position when operating the mower. Pushing the throttle all the way forward past FAST, will choke the engine. See figure 14.

GEAR SHIFT LEVER

The gear shift lever is used to shift into one of the forward gears, "NEUTRAL" or "REVERSE." See figure 14.

IGNITION SWITCH

Turn the key to the "START" position to start the engine. When the engine is running, let the key return to the "ON" position. To stop the engine, turn the key to the left to the "OFF" position and remove it to prevent accidental starting. See figure 14.

LIGHT SWITCH

Push the light switch to turn on the lights. The lights will only operate when the engine is running. See figure 14.

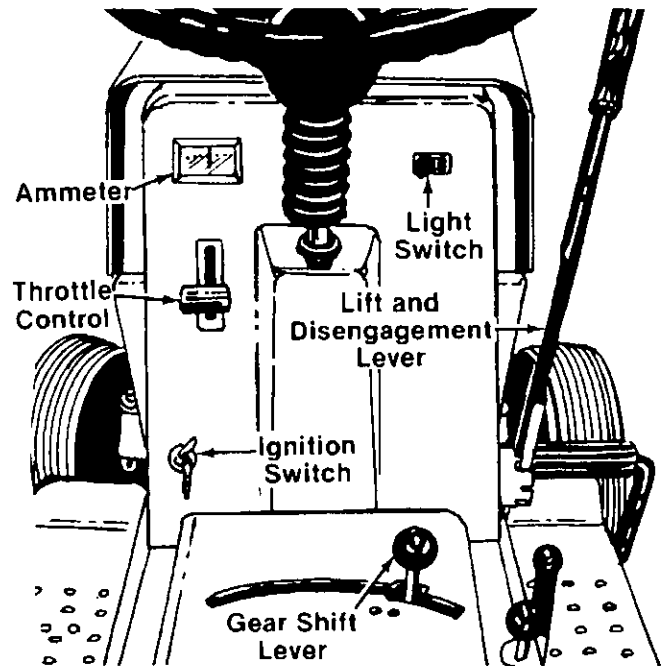

FIGURE 14.

AMMETER

The ammeter registers the rate of battery charge or discharge. The ammeter will register on the discharging side when starting the engine. It

should register on the opposite side (charging) when the engine is running in the fast position until the battery is completely charged. With a fully charged battery or with the engine idling, the ammeter will not show a charge. See figure 14.

CLUTCH-BRAKE PEDAL

The clutch-brake pedal is located on the right side of the lawn tractor. Depressing the clutch-brake pedal part way disengages the clutch. Pressing the pedal all the way down disengages the clutch and engages the disc brake. See figure 15.



The clutch-brake pedal must be depressed to start the engine.

PARKING BRAKE

To set the parking brake, depress the clutch-brake pedal and press the parking brake knob down. To release the parking brake, depress and release the clutch-brake pedal. See figure 15.

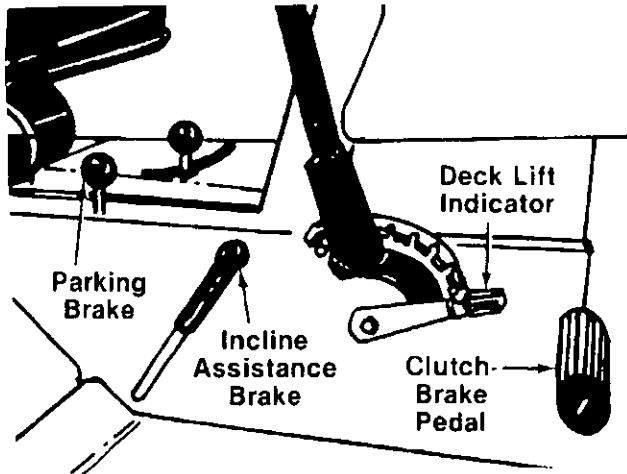

FIGURE 15.

INCLINE ASSISTANCE BRAKE

When stopping on a hill, hold the incline assistance brake lever back while you release the clutch-brake pedal until the lawn tractor begins to move, then release the lever. This lever permits smoother starts and clutch engagement by holding the tractor during the brake release/clutch engagement operation. See figure 15.

INTERLOCKS (Not Shown)

Interlock safety switches are located on the clutch-brake pedal, and the lift and disengagement lever and gear shift lever.

Before the engine will start, the clutch-brake pedal must be depressed all the way and the lift and disengagement lever must be in the disengaged position.

Before the unit can be shifted into reverse, the lift and disengagement must be in the disengaged position.

CUTTING CONTROLS

A. LIFT AND DISENGAGEMENT LEVER

The lift and disengagement lever is used to raise and lower the cutting deck. Pulling it all the way back and locking it disengages the blades. The lift and disengagement lever **must** be in the disengaged position when starting the engine and when shifting into reverse. See figure 14.

B. DECK LIFT INDICATOR

The deck lift indicator marks the position being used for the lift lever. Select the lift lever position desired, press the indicator lever outward, move it to the position immediately below the lift lever and release the indicator lever. See figure 15.

C. WHEEL HEIGHT ADJUSTER

Move the lever towards the wheel and set it in the desired height. See figure 16.

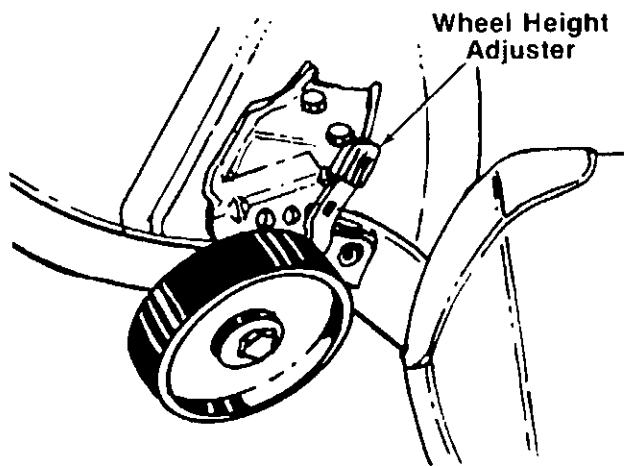

FIGURE 16.

D. SETTING THE CUTTING HEIGHT

1. Select the position for the lift lever which gives the desired cutting height. Move the deck lift indicator so that the lift lever can be returned to the same position after it is raised.
2. Set the wheel height adjusters on the deck so that the wheels are $\frac{1}{4}$ to $\frac{1}{2}$ inch above the ground.

To set the cutting deck in the suspended position, set the height of cut stop in the desired cutting height and then set the deck wheels so they just clear the ground.

OPERATION



CAUTION

1. Keep all shields in place.
2. Before leaving operator's position:
 - a. Shift transmission to neutral
 - b. Set parking brake
 - c. Disengage attachment clutch
 - d. Shut off engine
 - e. Remove ignition key
3. Wait for all movement to stop before servicing machine.
4. Keep people and pets a safe distance away from machine.
5. Look to the rear before backing up.

TIRE PRESSURE

For shipping purposes, the tires on your unit may be over-inflated. Tire pressure should be reduced before unit is put into operation. Recommended operating tire pressure should be 10 p.s.i.

Check sidewall of tire for manufacturer's maximum tire pressure. If this information does not appear on your tire, maximum tire pressure under any circumstances is 30 p.s.i. Equal tire pressure should be maintained on all tires.

STARTING THE ENGINE



NOTE

To open the hood, simply lift up on both sides of the hood.

1. Service the engine with oil and gasoline as described in the engine manual.
2. Depress the clutch-brake pedal and set the parking brake. See figure 15.
3. Place the lift and disengagement lever in the DISENGAGED position. See figure 15.



NOTE

This unit is equipped with a safety interlock system for your protection. The purpose of the safety interlock system is to prevent the engine from cranking or starting unless the clutch-brake pedal is depressed and the lift and disengagement lever is in the disengaged position. In addition, the lift and disengagement lever must be in the disengaged position when the unit is put into reverse or the engine will shut off.



WARNING

Do not operate the lawn tractor if the interlock system is malfunctioning because it is a safety device, designed for protection.

4. Set the throttle control in the CHOKE position. See figure 14.
5. Turn the ignition key to the "START" position. When the engine is running, let the key return to the "ON" position. See figure 14.
6. Move the throttle control to desired engine speed.

STOPPING THE ENGINE

Turn the ignition key to the left to the "OFF" position. Remove the key to prevent accidental starting.



NOTE

A brief break-in period is essential to ensure maximum engine and mower life. The break-in consists of running the engine at half speed for a period of time required to use one tank of gasoline. It is also recommended to change crankcase oil after the first 5 hours of operation.



IMPORTANT

If you strike a foreign object, stop the engine. Remove wire from spark plug, thoroughly inspect the unit for any damage, and repair the damage before restarting and operating the mower.

OPERATING THE MOWER

1. Set the desired cutting height.
2. Start the engine as instructed in previous column.
3. Move throttle control to desired engine speed.
4. Depress the clutch-brake pedal and shift into first gear or reverse.
5. Release clutch-brake pedal slowly to put unit into motion.
6. Depress the clutch-brake pedal when shifting gears.



NOTE

Do not force the gear shift lever!

- The lawn tractor is brought to a stop by depressing the clutch-brake pedal. The drive belt will be disengaged and the brake will be applied.



CAUTION

If the unit is not to be used for a long period, place the gear shift lever in NEUTRAL, stop the engine, set the parking brake and remove the key. DO NOT leave the machine on an incline.

OPERATING THE CUTTING BLADES

The cutting blades may be engaged while the lawn tractor is moving or standing still. DO NOT engage the cutting blades abruptly as the sudden belt tension on the pulley may cause the engine to stall.



WARNING

When the blade drive is engaged, keep feet and hands away from the discharge opening, the blades or any part of the deck.

Move the lift and disengagement lever into the DISENGAGED position to raise the deck and disengage the blades.



NOTE

When the machine is used for other than mowing operations, the blade drive should be disengaged.

GRASS CATCHER Model No. 015 is available as optional equipment for the lawn tractor shown in this manual.



WARNING

The mower should not be operated without the entire grass catcher or chute deflector in place.



NOTE

Under normal usage bag material is subject to wear, and should be checked periodically. Be sure any replacement bag complies with the mower manufacturer's recommendations.

For replacement bags, use only factory authorized replacement bag No. 764-0121.

ADJUSTMENTS

SEAT ADJUSTMENT

The seat may be adjusted to one of three positions. Refer to seat installation section of assembly instructions.

STEERING WHEEL ADJUSTMENT

There are four height positions for the steering wheel. To adjust the height of the steering wheel, remove the hairpin cotter and clevis pin on the steering shaft. Place the steering wheel in the position desired and secure with hairpin cotter and clevis pin. Refer to figure 10.

WHEEL ADJUSTMENT

The caster (forward slant of the king pin) and the camber (tilt of the wheels out at the top) require no adjustment. Automotive steering principles have been used to determine the caster and camber on the tractor. The front wheels should toe-in 1/8 inch.

To adjust the toe-in, follow these steps.

- Remove the hex nut and lock washer, and drop the tie rod end from the wheel bracket. See figure 17.
- Loosen the hex jam nut on tie rod.
- Adjust the tie rod assembly for correct toe-in.

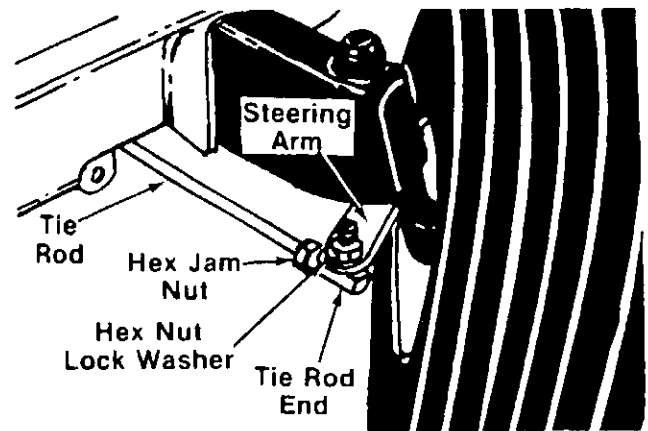

FIGURE 17.

Dimension "B" should be approximately 1/8" less than Dimension "A." See figure 18.

- To increase Dimension "B," screw tie rod into tie rod end.
- To decrease Dimension "B," unscrew tie rod from tie rod end.
- Reassemble tie rod. Check dimensions. Readjust if necessary.

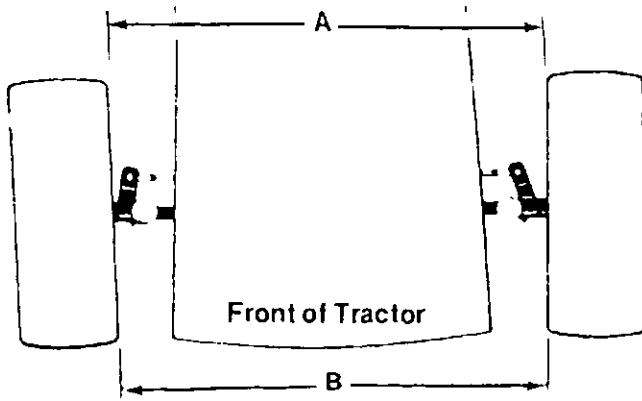

FIGURE 18. TOE-IN DIAGRAM

CARBURETOR ADJUSTMENT



If any adjustments are made to the engine while the engine is running (e.g. carburetor), disengage all clutches, and blades. Keep clear of all moving parts. Be careful of heated surfaces and muffler.

Minor carburetor adjustment may be required to compensate for differences in fuel, temperature, altitude and load. To adjust the carburetor, refer to the separate engine manual packed with your unit.

BRAKE ADJUSTMENT

During normal operation of this machine, the brake is subject to wear and will require periodic examination and adjustment.



Do not have the engine running when you adjust the brake.

To adjust the brake, proceed as follows.

1. Tighten the inside nut until the cam lever can not be moved by hand.
2. Loosen the inside nut until the cam lever can be pushed forward so that there is a 1/8" to 3/16" space between the cam lever and stop bolt. See figure 19.

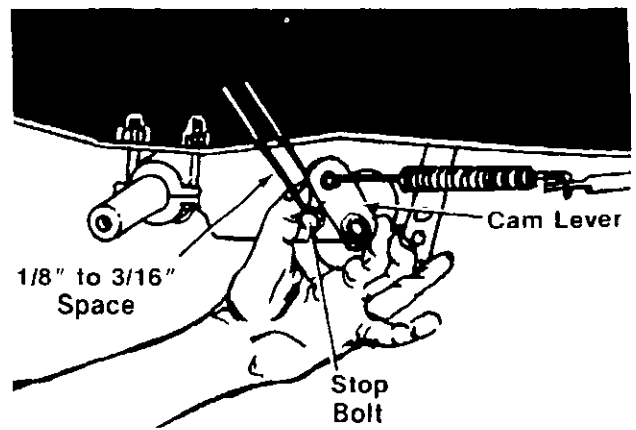

FIGURE 19.

3. Tighten the outside nut against the inside nut, using two 1/2" wrenches. See figure 20.



Friction pads must be replaced when the inside of cam lever touches the housing.

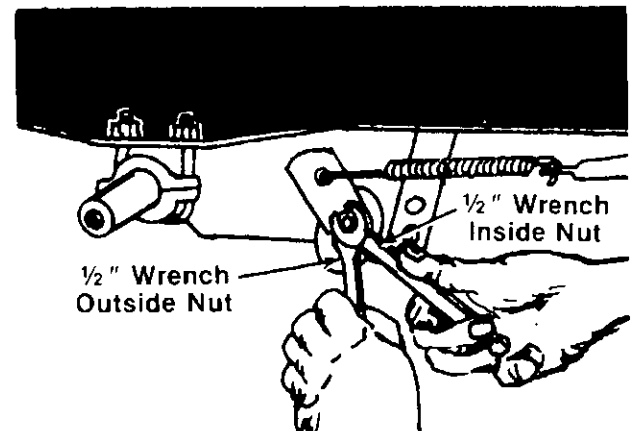

FIGURE 20.

LUBRICATION

STEERING GEARS

Lubricate teeth of steering gears with automotive multi-purpose grease after every 25 hours of operation or once a season. See figure 21.

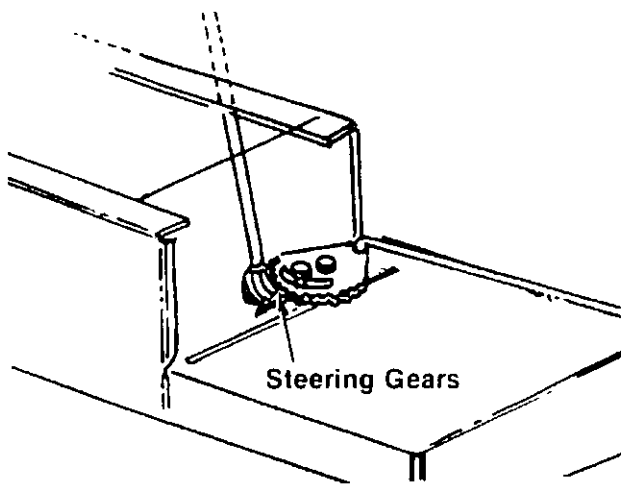

FIGURE 21.

STEERING SHAFT

Lubricate steering shaft at least once a season with light oil.

TRANSAXLE

The transaxle is lubricated and sealed at the factory and does not require checking. If disassembled for any reason, lubricate with 24 oz. of E.P. Lithium grease.

FRONT WHEELS

The front wheels are provided with grease fittings. Lubricate at least once a season with automotive multi-purpose grease.

PIVOT POINTS

Lubricate all pivot points with light oil at least once a season.

MAINTENANCE



WARNING

Disconnect the spark plug wire and ground against the engine before performing any repairs or maintenance.

CRANKCASE OIL

Check the oil level in the crankcase before each use of the machine and after every five hours of operation. Oil level should be maintained as instructed in the separate engine manual.

After the first five hours of operating a new engine, drain the oil from the crankcase while engine is still hot and refill crankcase with new oil; thereafter change the oil every 25 hours of operation. Refer to the engine manual.

AIR CLEANER

Under normal operating conditions, the air cleaner, located on top of the carburetor, must be serviced after every ten hours of use. Under extremely dusty operating conditions, the air cleaner must be serviced after every hour of operation. To service the air cleaner, refer to the separate engine manual packed with your unit.

CLEANING ENGINE AND BLADE HOUSING

Any fuel or oil spilled on the machine should be wiped off promptly. Grass, leaves, and other dirt must not be left to accumulate around the cooling fins of the engine or on any part of the machine.

Clean the underside of the blade housing after each mowing.

SPARK PLUG

The spark plug should be cleaned and the gap reset once a season. Spark plug replacement is recommended at the start of each mowing season; check engine manual for correct plug type and gap specification.

CUTTING BLADE

A. Removal for Sharpening or Replacement



WARNING

Be sure to disconnect and ground the spark plug wire and remove ignition key before working on the cutting blade to prevent accidental engine starting.

1. Remove the large bolt and lock washer which holds the blade and adapter to the blade spindle.
2. Remove the blade and adapter from the spindle. Be careful not to lose the key on the spindle.
3. If the blade or blade adapter needs replacing, remove the two small bolts, lock washers and nuts which hold the blade to the adapter.

B. Sharpening

Remove the cutting blade by following the directions of the preceding section.

When sharpening the blade, follow the original angle of grind as a guide. It is **extremely important** that each cutting edge receives an equal amount of grinding to prevent an unbalanced blade. An unbalanced blade will cause excessive vibration when rotating at high speeds, may cause damage to the mower and could break, causing personal injury.

The blade can be tested for balance by balancing it on a round shaft screwdriver. Remove metal from the heavy side until it balances evenly.

NOTE

It is recommended that the blade always be removed from the adapter for the best test of balance.

C. Reassembly

Before reassembling the blade and the blade adapter to the unit, lubricate the spindle and the inner surface of the blade adapter with light oil. Lubricating the bolt holes, bolts and inner surface of the nuts with light oil is also recommended. A 4 oz. plastic bottle of light oil lubricant is available. Order part number 737-0170. Engine oil may also be used.

When replacing the blade, be sure to install the blade with the side of the blade marked "Bottom" (or with part number) facing the ground when the mower is in the operating position. Make certain key is in place on the crankshaft.

Blade Mounting Torque

3/8" Dia. Bolt 375 in. lb. min., 450 in. lb. max.

5/16" Dia. Bolt 150 in. lb. min., 250 in. lb. max.

To insure safe operation of your unit, ALL nuts and bolts must be checked periodically for correct tightness.

FUEL FILTER

Your unit is equipped with a replaceable in-line fuel filter. Replace filter whenever contamination or discoloration is noticed. Order replacement filter through your engine authorized service dealer.

DRIVE BELT REMOVAL AND REPLACEMENT



Disconnect the spark plug wire and ground it against the engine.

NOTE

Figures 22 through 26 are shown with the unit tipped up for clarity. It is not necessary to tip the unit to remove the belts.

1. Place the lift lever in the disengaged position.
2. Remove the two hex bolts (belt keepers) from the engine pulley belt guard. See figure 22.

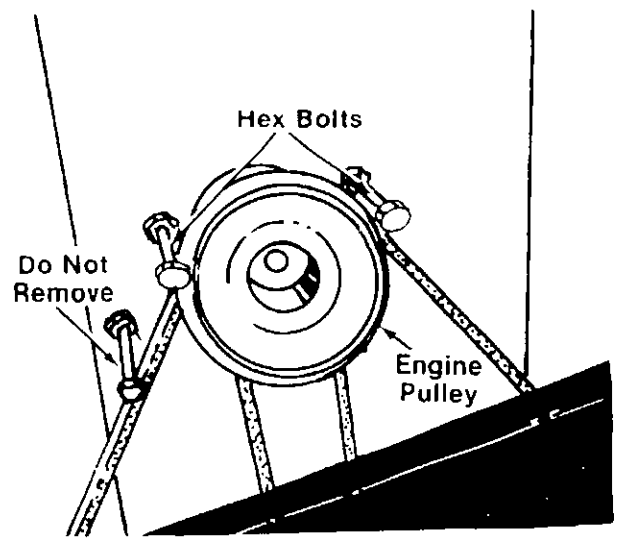

FIGURE 22.

3. Unhook the deck belt from the engine pulley.
4. Remove the two bolts, lock washers and nuts on each side of the frame which hold the engine pulley belt guard to the frame. See figure 23.

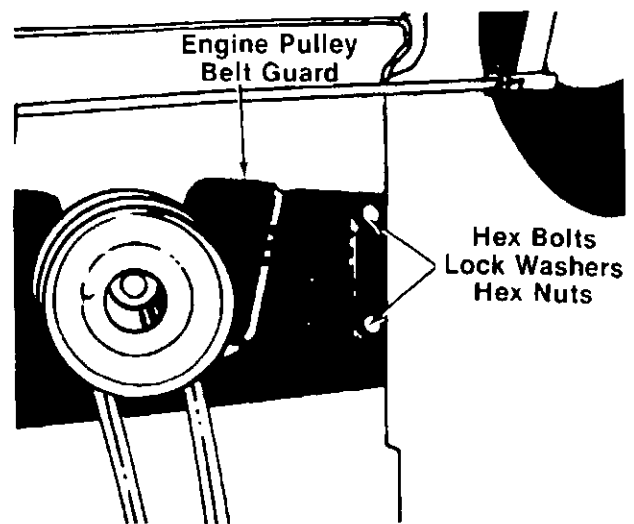

FIGURE 23.

5. Remove the engine pulley belt guard by slipping it back and to the right. See figure 24.

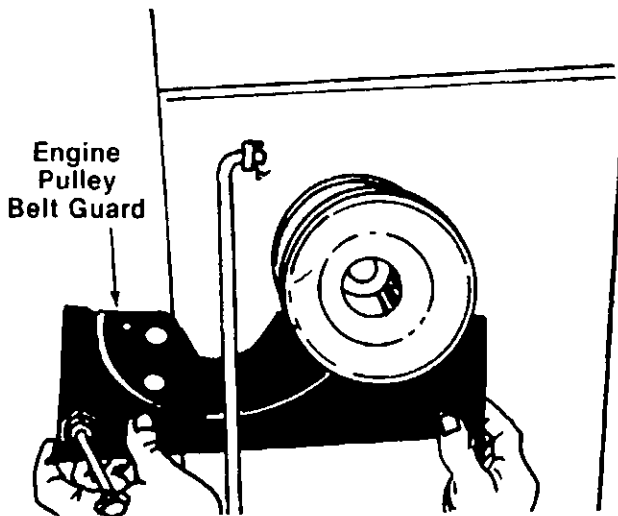

FIGURE 2.

6. Remove the bolt, lock washer and nut which hold the idler pulley to the idler bracket. See figure 25.

NOTE

Upon reassembly, the hub side of the idler pulley must be assembled against the idler bracket.

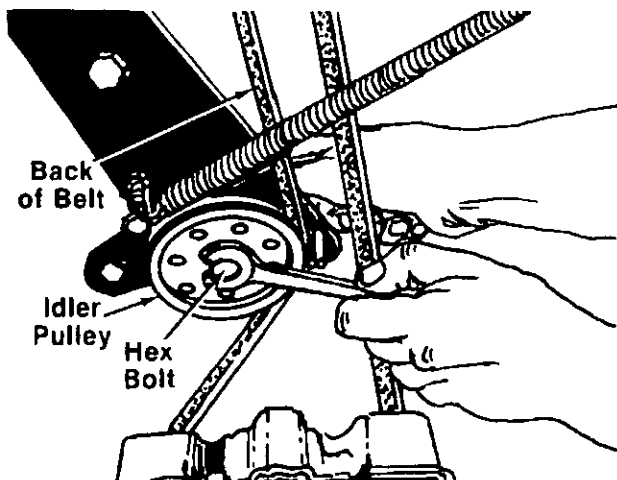

FIGURE 25.

7. Remove two self-tapping screws which hold the transaxle belt guard to the top of the transaxle. See figure 26.
8. Remove the transaxle shift lever by removing the hex bolt and Belleville washer. Lift off the special "D" washer. See figure 26.
9. Slide the transaxle belt guard back. Remove the belt from the engine pulley. Lift the belt up and over the transaxle pulley.

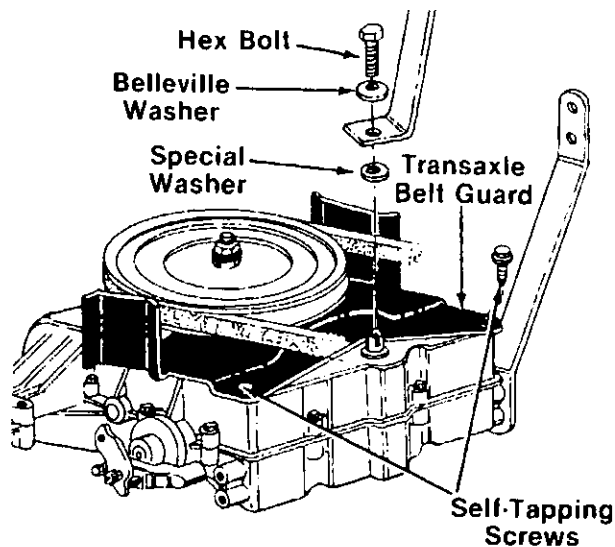

FIGURE 26.

10. Reassemble with a new belt, following instructions in reverse order.

IMPORTANT

The belt must be reassembled as shown in figure 25, with the back of the belt (flat side) against the idler pulley. The belt must be inside the pins. Failure to assemble the belt correctly will damage the belt.

BATTERY REMOVAL OR INSTALLATION



When removing the battery, follow this order of disassembly to prevent the screwdriver from shorting against the frame.

1. Remove the Negative cable.
2. Remove the Positive cable.

To install a battery:

1. Attach the Positive cable.
2. Attach the Negative cable.

JUMP STARTING

1. Attach the first jumper cable from the Positive terminal of the good battery to the Positive terminal of the dead battery.
2. Attach the second jumper cable from the Negative terminal of the good battery to the FRAME OF THE UNIT WITH THE DEAD BATTERY.



WARNING

Failure to use this starting procedure could cause sparking, and the gas in either battery could explode.

BATTERY MAINTENANCE

1. Check periodically (every two weeks or before and after charging) to be sure electrolyte level is above the lowest line on battery. Add only distilled water or a good quality drinking water. NEVER add additional acid or other chemicals to battery after initial activation.
2. The battery should be checked with a hydrometer after every 25 hours of operation. If the specific gravity is less than 1.225, remove battery and recharge.
3. Coat the terminals and exposed wiring with a thin coat of grease or petroleum jelly for longer service and protection against electrolyte corrosion.
4. The battery should be kept clean. Any deposits of acid should be neutralized with soda and water. Be careful not to get this solution in the cells.

BATTERY STORAGE

1. Charge battery using normal methods. NEVER store discharged battery as it will not recover.
2. When storing battery for extended periods, disconnect battery cables. Removing battery from unit is recommended.
3. Store in cold, dry place.
4. Recharge battery whenever the specific gravity is less than 1.225, before returning to service, or every two months, whichever occurs first.

COMMON CAUSES FOR BATTERY FAILURE ARE:

1. Overcharging
2. Undercharging
3. Lack of water
4. Loose holds downs and/or corroded connections
5. Excessive loads
6. Battery electrolyte substitutes
7. Freezing of electrolyte



NOTE

THESE FAILURES DO NOT CONSTITUTE WARRANTY.

INSTALLATION OF TIRE TO RIM



WARNING

The following procedure must be followed when removing or installing a tire to the rim.

1. Be sure rim is clean and rust free.
2. Lubricate both the tire and rim generously.
3. Never inflate to over 30 p.s.i. to seat beads. Excessive inflation pressure when seating beads may cause tire/rim assembly to burst with force sufficient to cause serious injury.

OFF-SEASON STORAGE

If the machine is to be inoperative for a period longer than 30 days, prepare for storage as follows.

1. Clean the engine and the entire unit thoroughly.
2. Lubricate all lubrication points. Wipe the entire machine with an oiled rag to protect the surfaces.
3. Refer to the engine manual for correct engine storage instructions. The engine must be completely drained of fuel to prevent gum deposits from forming on essential carburetor parts, fuel lines and fuel tanks.
4. Refer to battery storage instructions in previous column.
5. Store unit in a clean, dry area.



CAUTION

When storing any type of power equipment in an unventilated or metal storage shed, care should be taken to rust proof the equipment. Using a light oil or silicone, coat the equipment, especially any chains, springs, bearings and cables.

TROUBLE SHOOTING CHART FOR ELECTRIC START MODELS

TROUBLE	LOOK FOR	REMEDY
Engine will not crank	Battery installed incorrectly	The battery must be installed with the negative, identified at the terminal post by (Neg, N or -), grounded. The positive (Pos, P or +) attaches to the large cable from the solenoid. The small red wire from the fuse holder or circuit breaker is also attached to the positive terminal.
	Blown fuse or circuit breaker	Replace fuse with 7½ amp. fuse ¼ x 1¼" lg. Circuit breaker will reset itself when it cools off. Fuses or circuit breakers seldom open or fail without a reason. The problem must be corrected. Check for loose connections in the fuse holder. Replace fuse holder if necessary. A dead short may be in the cranking or charging circuit where the insulation may have rubbed through and exposed the bare wire. Replace the wire or repair with electrician's tape if the wire strands have not been damaged. Note: Look for a wire pinched between body panels, burned by the exhaust pipe or muffler or rubbed against a moving part.
	Battery is dead or weak	<p>Use a hydrometer to check the condition of the battery. The Specific Gravity (s.g.) should be 1.265 at 80°F. (1.215 s.g. minimum needed for cranking engine). The reason for the battery failing must be determined. (1) Defective battery. Battery will not accept or hold a full charge. (2) Short circuit. Check for grounded wire. (3) Charging system not working, either engine alternator or trickle charger.</p> <p>Trickle Charger. Check with multimeter. Charger 725-0578—input 120 V A.C., no load output 13.5 V D.C., rated load current 1 amp. Charger 725-0507—input 120 V A.C., no load output 17.4 V D.C., rated load current 1/2 amp.</p> <p>Alternator (dual or single circuit) The charging system is an alternator located under the flywheel. It is unregulated and rated 3 amp. at 3600 r.p.m. A diode (rectifier) is located in the output lead just before the wire harness plug on the engine side.</p> <div style="text-align: center;"> </div> <p>The diode changes A.C. to D.C. to charge the battery. A bad diode can either fail to charge the battery or discharge the battery if the alternator is shorted as well as the diode. To test: (1) Disconnect charger lead from the battery (small red wire). (2) Connect 12 V small test lamp between the 3 amp. D.C. charge lead and the positive terminal of the battery. (3) With the engine off, the lamp should not light. If it does, the diode and possibly the alternator should be replaced. (4) Start the engine. The lamp should light. If it does not, the alternator (stator) or lead wire is bad and should be replaced.</p>
Mechanical failure. (Wires and switches)	The interlock system includes two mechanical activated switches which are wired in series in the circuit used to energize the starter solenoid. While testing the interlock system, you will make the mower temporarily unsafe by permitting the engine to be started with the blade and clutch engaged. WARNING: While testing, disengage the clutch, shut off the blade control, set the parking brake and place the gear shift lever in neutral. Attach a wire (minimum 18 gauge) to the positive terminal of the battery and touch the other end to the small terminal on the solenoid. If the engine does not crank: (1) There is a loose connection or poor ground. (2) The solenoid may be bad. The solenoid can be checked by using a heavy wire (#8 gauge minimum) and jumping between the two large terminals. If the engine cranks, the solenoid is bad. (3) If the engine does not crank when you jump the solenoid, have the starter motor tested by an authorized engine dealer. If the engine does crank, the problem is with one of the safety switches, ignition switch or the wire between the fuse holder (or circuit breaker) and the small terminal on the solenoid. Note: Look for a poor connection at the switches or a defective switch. Replace if necessary.	
Engine cranks but will not start	Throttle or choke not in starting position	Check owner's guide for correct position for throttle control and choke (if separate control) for starting.

TROUBLE SHOOTING CHART FOR ELECTRIC START MODELS

TROUBLE	LOOK FOR	REMEDY
	No spark to spark plug	Spark plug lead disconnected. Connect lead. Hold spark plug lead away from engine block about 1/8". Crank engine. There should be a spark. If not, have engine repaired at authorized engine service dealer. Faulty spark plug. To test, remove spark plug. Attach spark plug lead to spark plug. Ground the spark plug body against the engine block. Crank the engine. The spark plug should fire at the electrode. Replace if it does not.
	No fuel to the carburetor	Gasoline tank empty. Fill. Fuel valve shut off. Open valve. Valve is located either at the bottom of the fuel tank or on the carburetor. Fuel line plugged. Remove and clean.
	Air filter dirty	If the air cleaner is dirty, the engine may not start. Clean or replace as recommended by the engine manufacturer.
Engine smokes	Engine loses crankcase vacuum	Dipstick not seated or broken. Replace defective part. Engine breather defective. Replace.
Excessive vibration	Bent or damaged blade spindle	Stop engine immediately. Check all pulleys, blade adapters, keys and bolts for tightness and damage. Tighten or replace any damaged parts.
	Bent blade	Stop engine immediately. Replace damaged blade. Only use original equipment blades.
Mower will not discharge grass or leaves uncut strips	Engine speed low Transmission selection Blades short or dull	Throttle must be set between 3/4 and full throttle. Use lower transmission gear. The slower your ground speed, the better the quality of cut. Sharpen or replace blades (uncut strip problem only).

13618

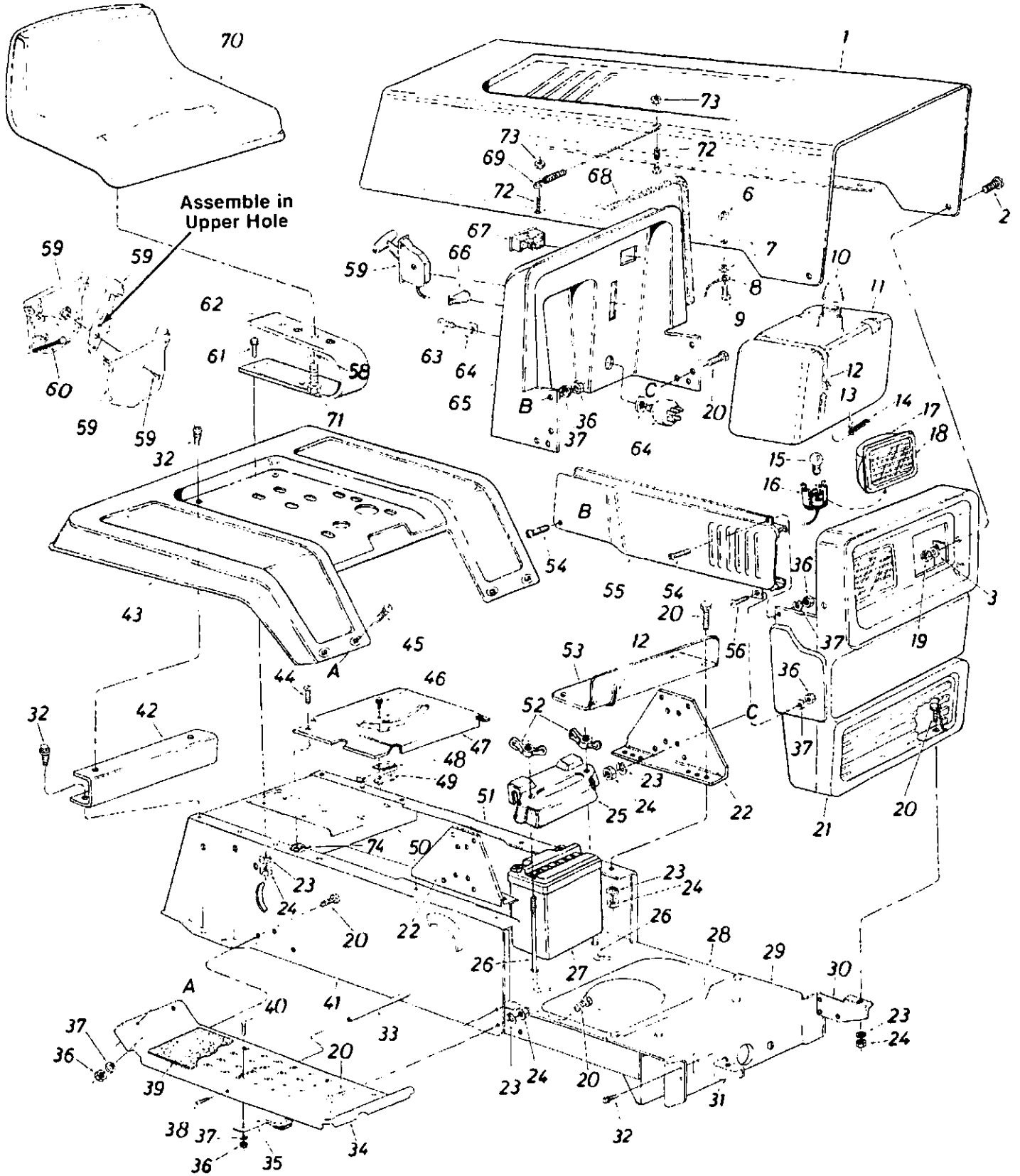

13618

PARTS LIST FOR MODEL 13618 LAWN TRACTOR

REF. NO.	PART NO.	COLOR CODE	DESCRIPTION	NEW PART	REF. NO.	PART NO.	COLOR CODE	DESCRIPTION	NEW PART
1	15808		Hood		40	710-0134		Carriage Bolt 1/4-20 x .62" Lg.*	
2	710-0255		Truss Hd. Scr. 1/4-20 x .75" Lg.*	N	41	14602		R.H. Side Frame	
3	736-0463		Fl-Wash. .296" I.D. x .62" O.D.		42	15848		Fender Mount Brace	N
6	712-0272		Hex Sems Nut #10-24 Thd.*		43	15887		Rear Fender	N
7	736-0931		Fl-Wash. .203" I.D. x .41" O.D. x .040		44	710-0351		Truss Mach. Tap Screw #10 x .50"	
8	727-0290		Hood Stop		45	710-0167		Carriage Bolt 1/4-20 x .50" Lg.*	
9	710-0473		Truss Hd. Scr. #10-24 x 1/2" Lg.*		46	710-0473		Truss Hd. Scr. #10-24 x .50" Lg.*	
10	723-0155		Fuel Cap Gauge		47	15823		Transmission Panel	N
11	751-0172		Fuel Tank		48	725-0759		Reverse Safety Switch	
12	726-0209		Tie Strap		49	726-0222		Insulator Nut Plate	
13	726-0207		Hose Clamp		50	14607		Hitch Plate	
14	751-0173		Fuel Line		51	14603		L.H. Side Frame	
15	725-0963		Lamp	N	52	712-0113		Wing Nut 1/4-20 Plastic	
16	725-0964		Socket	N	53	14605		Fuel Tank Support	
17	731-0705		Headlight Housing	N	54	710-0255		Truss Hd. Scr. 1/4-20 x .75" Lg.*	
18	731-0706		Lens	N	55	15814		Side Cover—R.H.	N
19	712-0324		Hex Sems Ins. L-Nut 1/4-20 Thd.			15815		Side Cover—L.H. (Not Shown)	N
20	710-0118		Hex Bolt 5/16-18 x .75" Lg.*		56	710-0286		Truss Mach. Scr. 1/4-20 x .50" Lg.*	
21	15804		Grille	N	58	736-0921		L-Wash. 1/2" I.D.*	
22	15818		Dash Support Bracket	N	59	831-0692		Throttle Control Box Ass'y.	N
23	736-0119		L-Wash. 5/16" I.D.*		60	746-0500		Throttle Control Wire	
24	712-0267		Hex Nut 5/16-18 Thd.*		61	710-0376		Hex Bolt 5/16-18 x 1.00" Lg.*	
25	731-0708		Battery Cover	N	62	732-0458		Seat Spring 5.5" High	N
26	711-0222		Battery Hold Down Rod		63	725-0201		Ignition Key	
27	725-0514		12V—Battery		64	725-0267		Ignition Switch	
28	14606		Lower Frame		65	15810		Dash Panel	N
29	14619		Front Pivot Brk't.		66	725-0634		Light Switch	
30	15821		Grille Mount Brk't.—L.H.	N	67	725-0925		Ammeter	N
31	15822		Grille Mount Brk't.—R.H.	N	68	731-0511		Molding Strip	
32	710-0726		Hex Wash. Hd. AB-Tap Scr. 5/16 x .75" Lg.		69	732-0462		Hood Spring	N
33	738-0526		Running Board Rod		70	757-0299		Seat Ass'y.	
34	14604		Running Board (R.H. & L.H.)		71	710-0493		Hex Bolt 1/2-13 x 1.0" Lg. (2 Req'd.)	
35	761-0169		Blade Brake Ass'y.		72	710-0749		Hex Bolt #10-24 x 1.0" Lg.	
36	712-0287		Hex Nut 1/4-20 Thd.*		73	712-0102		Hex Top L-Nut #10-24	
37	736-0329		L-Wash. 1/4" I.D.*		74	726-0139		Speed Nut #10Z	
38	710-0323		Truss Mach. Scr. 5/16-18 x .75" Lg.*						
39	723-0360		Foot Pad						

(615—Red)

*For faster service obtain standard nuts, bolts and washers locally. If these items cannot be obtained locally, order by part number and size as shown on parts list.

When ordering parts, if color or finish is important use the appropriate color code shown above. (e.g. Red Finish—11836 (615).)

 **NOTE**

Specifications subject to change without notice or obligation.

13618

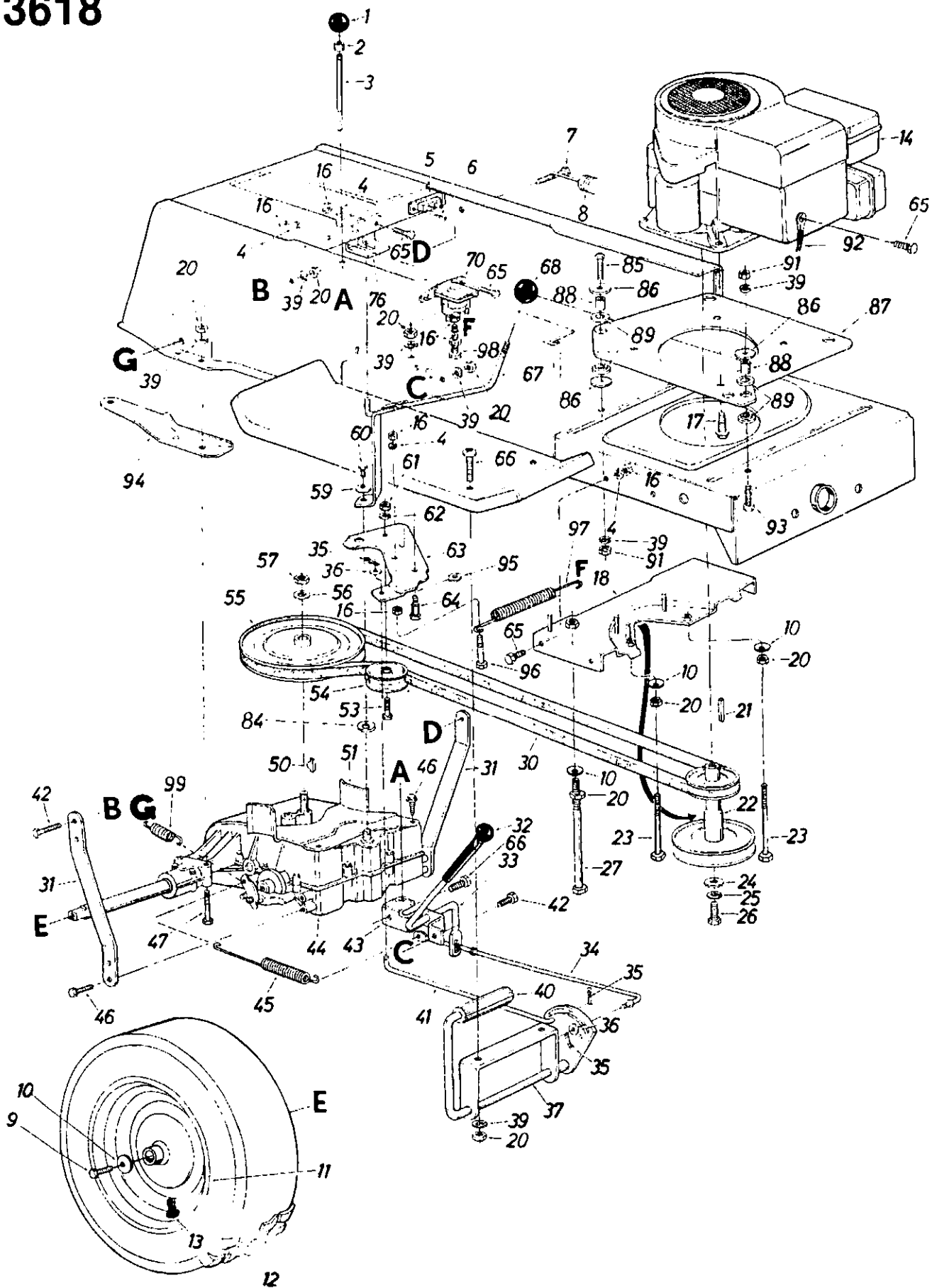

13618

PARTS LIST FOR MODEL 13618 LAWN TRACTOR

REF. NO.	PART NO.	COLOR CODE	DESCRIPTION	NEW PART	REF. NO.	PART NO.	COLOR CODE	DESCRIPTION	NEW PART
1	720-0187		Ball Knob 1.25" O.D. x 1/4"-20 Thd.		45	732-0413		Ext. Spring .590" O.D. x 7.08" Lg.	
2	732-0145		Compression Spring .30" O.D. x 1.00" Lg.		46	710-0604		Hex Wash. Hd. AB-Tap Scr. 5/16 x .62" Lg.	
3	711-0742		Brake Lockout Rod		47	710-0378		Hex Bolt 5/16-18 x 2.50" Lg.*	
4	736-0329		L-Wash. 1/4" I.D.*		50	714-0129		#4 Hi-Pro Key 3/32 x 5/8" Dia.	
5	725-0459		Circuit Breaker		51	14631		Transaxle Belt Keeper	
6	710-0351		Truss Hd. Phil. Scr. #10 x 1/2" Lg.		53	710-0344		Hex Bolt 3/8-16 x 1.50" Lg.*	
7	710-0528		Hex Bolt 5/16-18 x 1.25" Lg.		54	756-0225		Flat Idler Pulley 3/8" I.D. x 2.75 O.D.	
8	732-0307		Ext. Spring .99" O.D. x 11.00" Lg.		55	756-0374		Transaxle Pulley	
9	710-0627		Hex Bolt 5/16-24 x .75" Lg.*		56	736-0921		L-Wash. 1/2" I.D.*	
10	736-0242		Bell-Wash. 5/16" I.D.		57	712-0922		Hex Nut 1/2-20 Thd.*	
11	734-0603		Rear Wheel Rim Only		59	736-0270		Bell-Wash. .26" I.D. x .75" O.D.	
12	734-0817		Rear Wheel Ass'y. Comp. Tire Only		60	710-0513		Hex Bolt 1/4-28 x .62" Lg.	
13	734-0255		Air Valve (Service Only)		61	712-0798		Hex Nut 3/8-16 Thd.*	
14	—		Engine—B&S 252707-0645-01		62	736-0169		L-Wash. 3/8" I.D.*	
16	712-0287		Hex Nut 1/4-20 Thd.*		63	14656		Idler Brkt. Ass'y	
17	710-0502		Hex Bolt 3/8-16 x 1.25" Lg.		64	738-0140		Shld. Scr. .437" Dia. x 1.80" Lg. (5/16-18)	
18	14643		Belt Guard Brkt. Ass'y.		65	710-0258		Hex Bolt 1/4-20 x .62" Lg.*	
20	712-0267		Hex Nut 5/16-18 Thd.*		66	710-0323		Truss Hd. Mach. 5/16-18 x .75" Lg.*	
21	714-0114		Sq. Key 1/4" x 1/4" x 2.00" Lg.		67	14627		Shift Lever Ass'y	
22	756-0373		Two Step Engine Pulley		68	720-0165		Ball Knob 1.25" O.D. x 3/8-16 Thd.	
23	710-0833		Hex Bolt 5/16-18 x 5.25" Lg.		70	725-0771		Solenoid	
24	736-0322		FI-Wash. 7/16" I.D. x 1.25" O.D. x .180		76	14630		Shift Lever Pivot Brkt.	
25	736-0171		L-Wash. 7/16" I.D.*		84	717-0234		Special Wash. 1.00" O.D.	
26	710-0757		Hex Bolt 7/16-20 x 1.50" Lg.		85	710-0158		Hex Bolt 5/16-24 x 1.25" Lg.*	
27	710-0833		Hex Bolt 5/16-18 x 5.25" Lg.*		86	736-0343		FI-Wash. 1.25" O.D. x .320" I.D.	
30	754-0266		"V"-Belt "A" Glass 85" Lg. Bare Back		87	14791		Engine Mounting Plate	
31	14653		Transaxle Brace		88	750-0539		Spacer	
32	720-0143		Grip (Hand Brake)		89	722-0153		Engine Mounting Grommet	
33	747-0386		Hill Holder Brake Handle		91	712-0123		Hex Nut 5/16-24 Thd.*	
34	747-0385		Brake Rod		92	725-0122		Electric Ground Wire	
35	714-0111		Cotter Pin 3/32" Dia. x 1.00"*		93	710-0624		Hex Bolt 5/16-24 x 1.50" Lg.*	
36	736-0204		FI-Wash. .344" I.D. x .625" O.D.		94	14770		Transaxle Support Brkt.—R.H.	
37	14623		Brake and Clutch Pedal Ass'y.			14769		Transaxle Support Brkt.—L.H. (Not Shown)	
39	736-0119		L-Wash. 5/16" I.D.*		95	736-0141		Wave Wash.	
40	735-0196		Foot Pedal Pad		96	710-0102		Hex Bolt 1/4-20 x 2.50" Lg.*	
41	747-0390		Clutch Rod		97	732-0384		Ext. Spring	
42	710-0118		Hex Bolt 5/16-18 x .75" Lg.*		98	710-0102		Hex Bolt 1/4-20 x 2.50" Lg.*	
43	14634		Brake Lock and Handle Support Brkt.		99	732-0303		Brake Return Spring	
44	—		Transaxle Complete						

13618

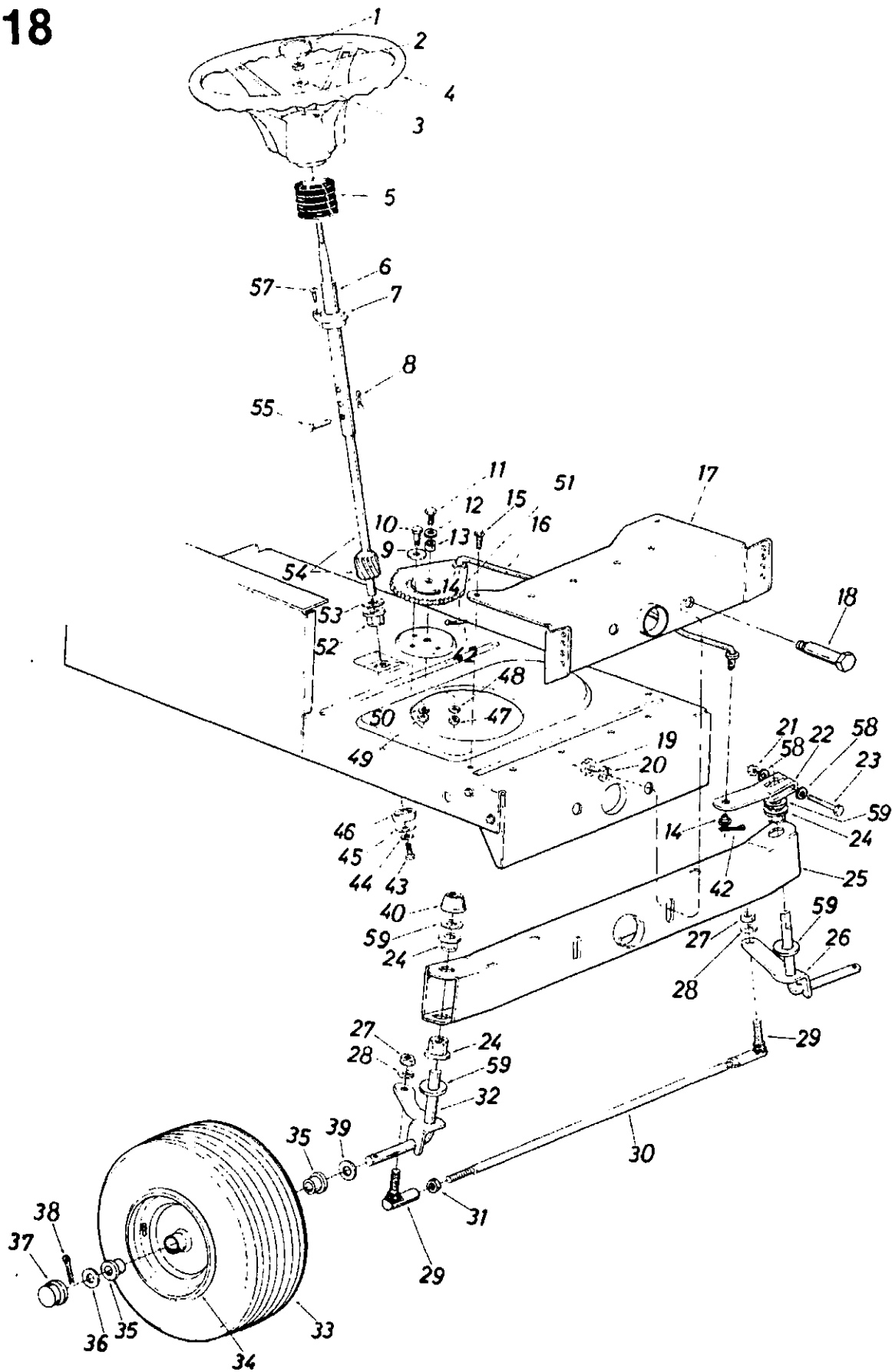

13618

PARTS LIST FOR MODEL 13618 LAWN TRACTOR

REF. NO.	PART NO.	COLOR CODE	DESCRIPTION	NEW PART	REF. NO.	PART NO.	COLOR CODE	DESCRIPTION	NEW PART
1	731-0220		Steering Wheel Cap		31	712-0711		Hex Jam Nut 3/8-24 Thd.*	
2	712-0267		Hex Nut 5/16-18 Thd.*		32	14650		Front Axle Ass'y.—R.H.	
3	736-0242		Belleville Wash. .345" I.D.		33	734-0998		Wheel Ass'y. Comp.	
4	731-0356		Steering Wheel			734-0498		Tire Only	
5	731-0559		Steering Bellow—4.5"		34	734-0997		Front Wheel Rim Only	
6	14775		Steering Column Ass'y.			741-0313		Bearing	
7	741-0356		Flange Bearing .890 I.D. x 1.36 O.D.			734-0255		Air Valve	
						737-0146		Grease Fitting	
8	714-0147		Internal Cotter Pin 1/4" Dia.		35	741-0313		Bearing	
9	736-0319		Fl-Wash. .438" I.D. x 1.37" O.D.		36	736-0285		Fl-Wash. .635 I.D. x 1.59" O.D.	
10	738-0141		Shoulder Bolt .437" Dia. x .35 Lg. 5/16-18 Thd.		37	731-0484		Front Wheel Hub Cap	
11	710-0152		Hex Bolt 3/8-24 x 1.0" Lg. (Grade 5)		38	714-0470		Cotter Pin 1/8" Dia. x 1.25" Lg.*	
12	736-0206		Fl-Wash. .38" I.D. x 1.0" O.D.		39	736-0156		Fl-Wash. .635" I.D. x 1.20" O.D.	
13	750-0535		Spacer .380" I.D. x .625" O.D. x .227		40	726-0214		Push Cap 5/8" Dia. Rod	
					42	714-0115		Cotter Pin 1/8" Dia. x 1.0" Lg.	
14	731-0658		Bushing		43	710-0538		Hex L-Bolt 5/16-18 x .62" Lg.*	
15	710-0726		Hex Wash. Hd. Self-Tap Scr.		44	736-0119		L-Wash. 5/16" I.D.*	
16	711-0691		Steering Drag Link		45	736-0231		Fl-Wash. .344" I.D. x 1.25" O.D.	
17	14619		Front Pivot Brkt.		46	750-0532		Spacer (Plastic)	
18	738-0527		Shoulder Bolt .498" Dia. x 2.04 Lg. 3/8-16 Thd.		47	712-0241		Hex Nut 3/8-24 Thd.*	
19	712-0798		Hex Nut 3/8-16 Thd.*		48	736-0169		L-Wash. 3/8" I.D.*	
20	736-0169		L-Wash. 3/8" I.D.*		49	712-0267		Hex Nut 5/16-18 Thd.*	
21	712-0237		Hex Cent. L-Nut 5/16-24 Thd.		50	736-0119		L-Wash. 5/16" I.D.*	
22	14611		Steering Arm Front Axle		51	717-0468		Steering Gear Segment	
23	710-0772		Hex Bolt 5/16-24 x 2.00" Lg. (Grade 5)		52	741-0225		Hex Flg. Brg. .634 I.D.	
24	741-0225		Hex Flg. Brg. .634 I.D.		53	736-0187		Fl-Wash. (Hardened)	
25	14608		Pivot Bar Ass'y.		54	738-0522		Steering Shaft Lower	
26	14649		Front Axle Ass'y.—L.H.		55	711-0684		Clevis Pin 1/4" Dia. x 1.00" Lg.	
27	712-0241		Hex Nut 3/8-24 Thd.*		57	710-0837		Oval Hd. Cr.—Sunk Scr. #10 x 5/8" Lg.	
28	736-0169		L-Wash. 3/8" I.D.*		58	736-0242		Bell-Wash.	
29	723-0156		Ball Joint 3/8-24 Thd.		59	736-0187		Fl-Wash. (Hardened)	
30	711-0613		Tie Rod						

(615—Red)

*For faster service obtain standard nuts, bolts and washers locally. If these items cannot be obtained locally, order by part number and size as shown on parts list.

When ordering parts, if color or finish is important use the appropriate color code shown above (e.g. Red Finish—11836 (615).)

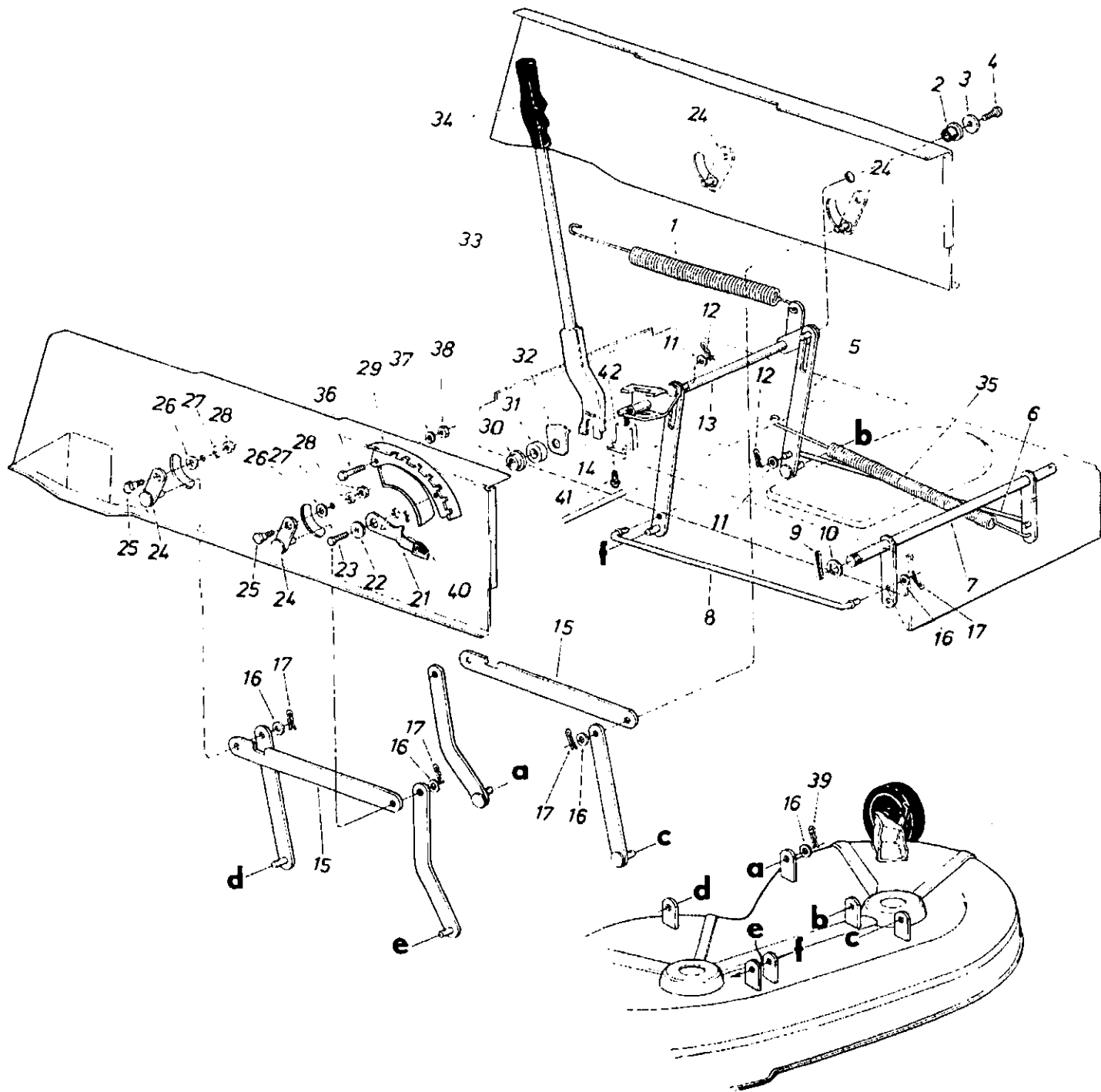

13618

PARTS LIST FOR MODEL 13618 LAWN TRACTOR

REF. NO.	PART NO.	COLOR CODE	DESCRIPTION	NEW PART	REF. NO.	PART NO.	COLOR CODE	DESCRIPTION	NEW PART
1	732-0307		Extension Spring .99" O.D. x 11.00" Lg.		24	09721		Pivot Link Ass'y.	
2	741-0313		Flange Bearing .634" I.D.		25	738-0140		Shld. Bolt .437" Dia. x .180" Lg. (5/16-18)	
3	736-0231		Fl-Wash. .344" I.D. x 1.125" O.D. x .125		26	736-0264		Fl-Wash. .344" I.D. x .62" O.D.	
4	710-0604		Hex Wash. Hd. 5/16-18 x .62" Lg.		27	736-0119		L-Wash. 5/16" I.D.*	
5	14802		Link Deck Lift Ass'y.		28	712-0267		Hex Nut 5/16-18 Thd.*	
6	711-0738		Stabilizer Rod		29	14633		Index Brkt.	
7	14647		Stabilizer Shaft Ass'y.		30	736-0341		Flange Wash. .628" I.D. x 1.25" O.D.	
8	711-0738		Stabilizer Rod		31	735-0216		Rubber Wash. 1.50" O.D. x .63" I.D. x .60	
9	714-0470		Cotter Pin 1/8" Dia. x 1 1/4" Lg.*		32	14654		Retainer Washer—Lift Handle	
10	736-0156		Fl-Wash. .635" I.D. x 1.12" O.D.		33	14645		Lift Handle Ass'y.	
11	736-0192		Fl-Wash. .531" I.D. x .940" O.D.		34	720-0157		Grip (Lift Handle)	
12	714-0101		Inter. Cotter Pin .50" Dia.		35	732-0410		Extension Spring .99" O.D. x 13.25" Lg.	
13	14641		Lift Shaft Ass'y.		36	710-0118		Hex Bolt 5/16-18 x .75" Lg.*	
14	14802		Link Deck Lift Ass'y.		37	736-0119		L-Wash. 5/16" I.D.*	
15	09735		Connecting Rod		38	712-0267		Hex Nut 5/16-18 Thd.*	
16	736-0300		Fl-Wash. .40" I.D. x .88" O.D.		39	714-0101		Inter. Cotter Pin	
17	714-0104		Inter. Cotter Pin For 3/8" Rod		40	08540		Knob	
21	732-0412		Deck Lift—Down Stop		41	710-0351		Hex AB-Tap Scr. #10 x .50" Lg.	
22	736-0231		Fl-Wash. .344" I.D. x 1.125" O.D. x .125		42	725-0803		Safety Switch	
23	710-0604		Hex Wash. Hd. 5/16-18 x .62" Lg.						

(615—Red)

*For faster service obtain standard nuts, bolts and washers locally. If these items cannot be obtained locally, order by part number and size as shown on parts list.

When ordering parts, if color or finish is important use the appropriate color code shown above. (e.g. Red Finish—11836 (615).)

13618

NOTE: This unit is not under warranty by the mower manufacturer. All Part Orders and Service must be handled through the local Authorized Tecumseh Service Dealer.



PEERLESS MODEL 813B

This unit is under warranty by Tecumseh Products Company. Parts and Service are available through all Tecumseh, Lauson Power Products Service Dealers. Check the "Yellow Pages" of your telephone directory under "Engines—Gasoline."

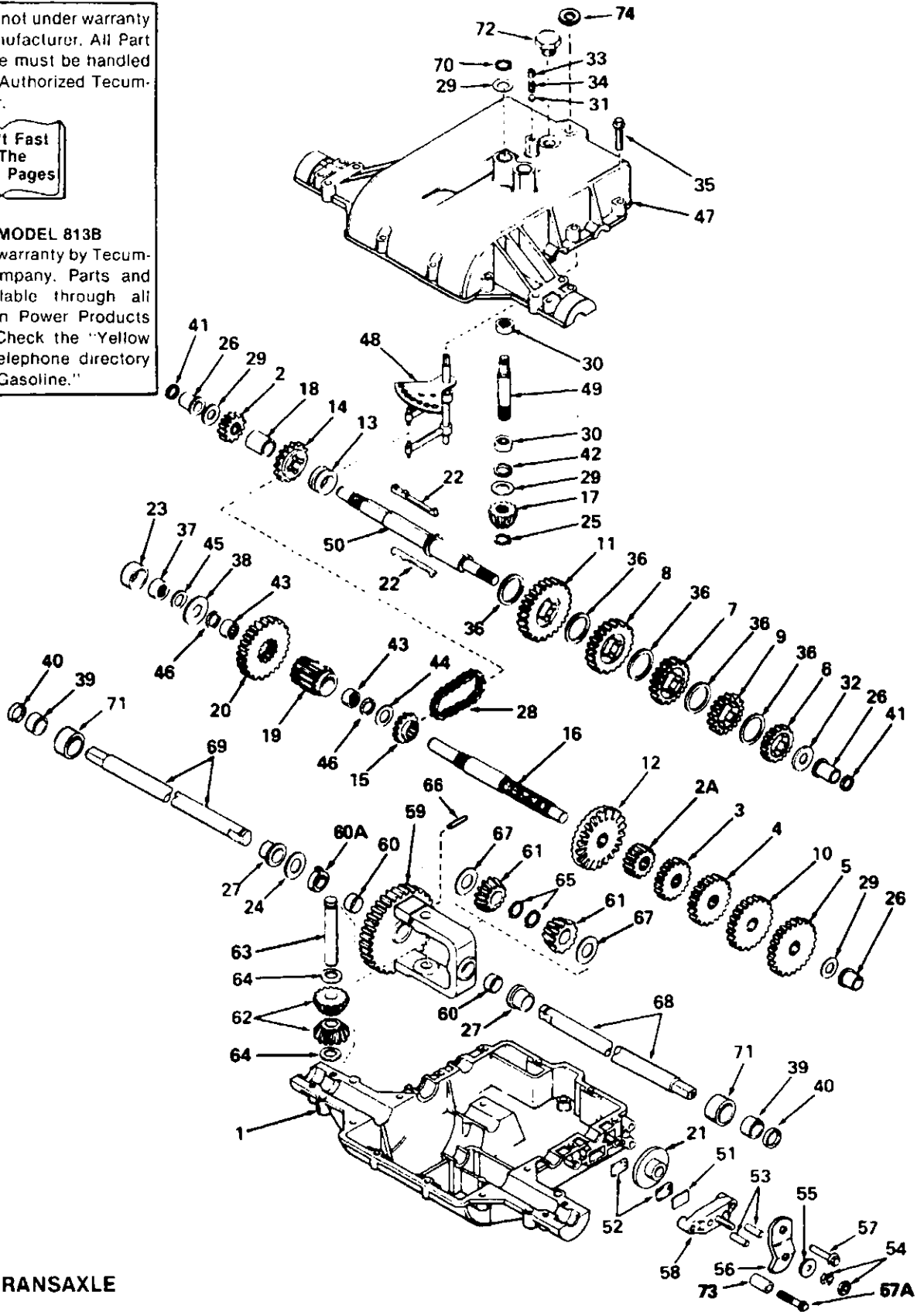

FIVE-SPEED TRANSAXLE
MODEL 813B
(717-0448)

13618

PARTS LIST FOR FIVE-SPEED TRANSAXLE MODEL 813B (717-0448)

REF. NO.	PART NO.	DESCRIPTION	REF. NO.	PART NO.	DESCRIPTION
1	PE-770071A	Case, Transaxle	39	PE-530105	Bearing, Needle
2	PE-778136	Gear, Spur (15 Teeth)	40	PE-788042	Seal, Oil
2A	PE-778145	Gear, Spur (12 Teeth)	41	PE-788051	Ring, Square Cut
3	PE-778151	Gear, Spur (15 Teeth)	42	PE-792001	Ring, Square Cut
4	PE-778126A	Gear, Spur (20 Teeth)	43	PE-780112	Bearing, Needle
5	PE-778129A	Gear, Spur (30 Teeth)	44	PE-780114	Washer, Flat
6	PE-778121A	Gear, Spur (20 Teeth)	45	PE-788052	Ring, Square Cut
7	PE-778124A	Gear, Spur (30 Teeth)	46	PE-788053	Ring, Square Cut
8	PE-778125	Gear, Spur (35 Teeth)	47	PE-772077B	Cover, Transaxle
9	PE-778123A	Gear, Spur (25 Teeth)	48	PE-784290	Rod and Fork Ass'y., Shift
10	PE-778127A	Gear, Spur (25 Teeth)	49	PE-776140	Shaft, Input
11	PE-778146A	Gear, Spur (37 Teeth)	50	PE-776184A	Shaft, Brake
12	PE-778137A	Gear, Bevel (42 Teeth)	51	PE-790007	Plate, Brake Pad
13	PE-784266	Collar, Shift	52	PE-790006	Pad, Brake
14	PE-786083	Sprocket (18 Teeth)	53	PE-786026	Pin, Dowel
15	PE-786082	Sprocket (9 Teeth)	54	PE-792075	Lock Nut, 5/16-24
16	PE-776181	Shaft, Counter	55	PE-792076	Washer, Flat
17	PE-778113A	Bevel Pinion, Input	56	PE-790004	Lever, Brake
18	PE-786074	Spacer	57	PE-792073	Screw, Hex Hd. Thread Forming, 1/4-20 x 1-1/4
19	PE-778138	Pinion, Output			
20	PE-778139	Gear, Output	57A	PE-792085	Screw, Hex Hd. Thread Forming, 1/4-20 x 2-1/4
21	PE-790003	Disc, Brake			
22	PE-792089A	Key	58	PE-790005	Holder, Brake Pad
23	PE-786075	Spacer	59	PE-778053A	Gear Ass'y., Differential (Incl. 2 of No. 60)
24	PE-780001	Washer			
25	PE-788040	Ring, Retaining	60	PE-780064	Bushing
26	PE-780105A	Bushing, Flanged	60A	PE-780120	Bushing
27	PE-780118	Bushing, Flanged	61	PE-778067	Gear, Bevel
28	PE-786081	Chain, Roller (No. 41 Chain, 24 Links)	62	PE-778068	Pinion, Bevel
			63	PE-786034	Pin Drive
29	PE-780072	Washer, Thrust	64	PE-780065	Washer, Thrust
30	PE-780086	Bearing, Needle	65	PE-792018	Ring, Retaining
31	PE-792077	Ball, Steel	66	PE-792040	Pin, Roll
32	PE-780109	Washer, Thrust	67	PE-780001	Washer, Thrust
33	PE-792078	Screw, Set, 3/8-16 x 3/8	68	PE-774420	Axle (14-7/8" Long)
34	PE-792079	Spring	69	PE-774419	Axle (13" Long)
35	PE-792073	Screw, Hex Hd. Thread Forming, 1/4-20 x 1-1/4	70	PE-792035	Ring, Retaining
			71	PE-786084	Spacer
36	PE-780108	Washer, Thrust	72	PE-792074	Plug
37	PE-780111	Bearing, Needle	73	PE-786066	Spacer
38	PE-780113	Washer, Flat	74	PE-792083	Washer

NOTE: This unit is not under warranty by the mower manufacturer. All Part Orders and Service must be handled through the local Authorized Tecumseh Service Dealer.



PEERLESS MODEL 813B

This unit is under warranty by Tecumseh Products Company. Parts and Service are available through all Tecumseh, Lauson Power Products Service Dealers. Check the "Yellow Pages" of your telephone directory under "Engines—Gasoline."

13618

Briggs and Stratton Engine

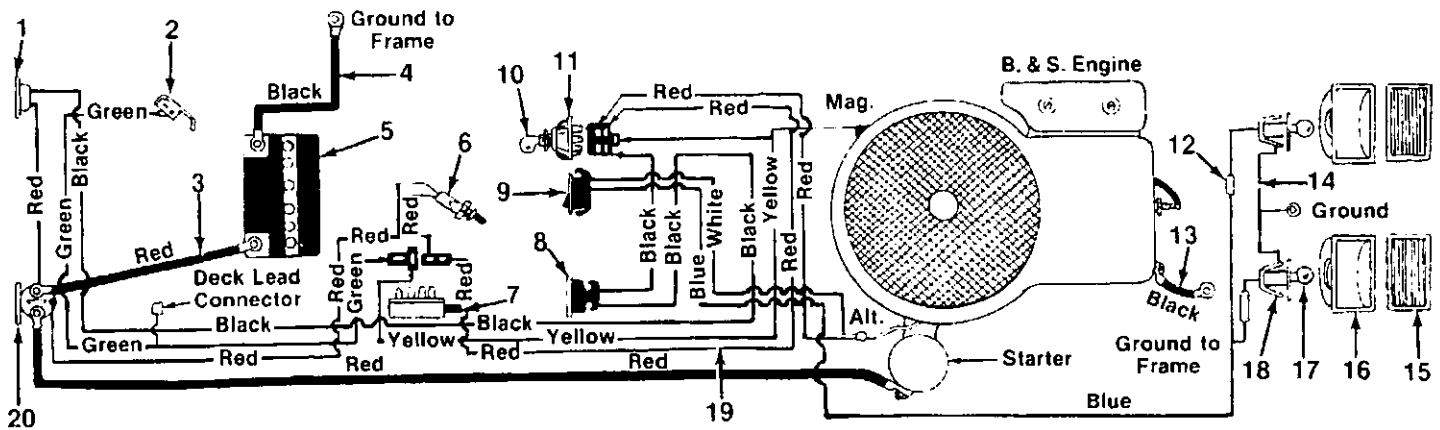

PARTS LIST FOR ELECTRICAL SYSTEM— BRIGGS AND STRATTON ENGINE

REF. NO.	PART NO.	DESCRIPTION
1	725-0459	Circuit Breaker
2	725-0759	Spring—Switch (Reverse Safety)
3	725-0150	Electric Wire (Red-Positive)
4	725-0975	Ground Wire 9.0" Lg. (Black-Negative)
5	725-0514	12 V-Battery
6	725-0577	Safety Switch (Clutch)
7	725-0803	Safety Switch (P.T.O.)
8	725-0925	Ammeter
9	725-0634	Light Switch
10	725-0201	Ignition Key
11	725-0267	Ignition Switch
12	725-0717	Tab Receptacle
13	725-0976	Ground Wire 7.25" Lg. (Black-Engine)
14	725-0967	Clip On Ground Wire
15	731-0706	Lens—Headlamp
16	731-0705	Headlight Housing
17	725-0963	Lamp
18	725-0964	Headlamp Socket
19	725-0941	Wire Harness
20	725-0771	Solenoid



YARD-MAN PARTS INFORMATION

POWER EQUIPMENT PARTS AND SERVICE

Parts and service for all YARD-MAN manufactured power equipment are available through the authorized service distributors listed below. All orders should specify the model number of your unit, parts numbers, description of parts and the quantity of each part required. **DO NOT SEND PARTS ORDER TO FACTORY.** Dealers should contact their area distributors identified by state abbreviation below.

MD ADAMS EQUIPMENT
DE 8001 Newell St.
WA-DC Silver Spring, MD 20910
N-VA (301) 585-1322
S-CA ALL SEASON EQUIPMENT
AZ 169 S. Hewes St.
Orange, CA 92669
(714) 639-7272
NC ALLISON-ERWIN CO.
SC 2920 N. Tryon Street
P.O. Box 32308
Charlotte, NC 28232
(704) 334-8621
" B & D INC.
2809 N. Vermilion St.
Box 1255
Danville, IL 61832
(217) 446-5167
ME M. J. COFFIN
N-NH 725 Broadway
Bangor, ME 04401
(207) 942-8289
CT VT CRANDALL-HICKS CO.
RI MA Route 9
S-NH 337 Boston Worcestpke
Southboro, MA 01772
(617) 485-6300
Jackson County FACTORY BRANCH
MI COMPANY
440 East Prospect
Jackson, MI 49203
(517) 783-2766
S FL FLORIDA TURF & GARDEN
EQUIP.
7275 NW 64th St.
Miami, FL 33166
(305) 592-3846

W-E-MI IDEAL MOWER SALES
N-W-OH 811 Woodward Heights
Ferndale, MI 48220
(313) 541-4660
N-CA IMPOSSIBLE EQUIPMENT
1880 Enterprise
P.O. Box 1016
W. Sacramento, CA 95691
(916) 371-9110
N FL LAWN PRODUCTS OF
AMERICA
565 S. Edgewood Ave.
Jacksonville, FL 32205
(904) 387-1512
PA S.P. LUMMUS CO., INC.
S-NJ 800 Industrial Hwy.
Pottstown, PA 19464
(215) 327-4920
WI MERCY CORP.
UP-W-MI 4080 N. Pt. Washington Rd.
P.O. Box 12145
Milwaukee, WI 53212
(414) 961-3200
N-NJ NIEMEYER CORP.
NY 1135 Phoenixville Pike
P.O. Box 1477
West Chester, PA 19380
(215) 431-7200
MO OZARK EQUIPMENT CO.
E-KS Hwy. 63 & Black Street
P.O. Box 784
Rolla, MO 65401
(314) 364-2180
UT POWERED PRODUCTS
NV 485 North 500 West
Bountiful, UT 84010
(801) 295-4148

OH RAHRIG SALES INC.
IN 108-110 W. Lima St.
Forest, OH 45843
(419) 273-2556
NM HUGO SCHULTE & CO.
6666 Fourth St.
Albuquerque, NM 87107
(505) 345-2633
NE STICKNEYS INC.
CO 101 Main St.
S E WY Sterling, CO 80751
N W KS (303) 522-2665
TX TIMBERLAND SAW CO.—
OK TIMSCO
AR 1603 E. Houston—Box 1227
LA Marshall, TX 75670
(214) 935-5251
TX WOODSON SALES CORP.
1720 N. Sylvania Ave.
Fort Worth, TX 76111
(817) 838-6736
OR R. M. WADE & CO.
W ID 10025 S. W. Allen Blvd.
Beaverton, OR 97005
(503) 641-1865
WA R.M. WADE & CO.
5808 S. 196
P.O. Box 58503
Kent, WA 98032
(206) 872-9233
CANADA MTD PRODUCTS CANADA
97 Kent Ave.
Kitchener, Ontario
Canada, N2G 4J1
(519) 579-5500
EXPORT DRAKE AMERICA CORP.
477 Madison Ave.
New York, NY 10022
(212) 758-5400

WARRANTY PARTS AND SERVICE POLICY

(0883)

The purpose of warranty is to protect the customer from defects in workmanship and materials, defects which are NOT detected at the time of manufacture. It does not provide for the unlimited and unrestricted replacement of parts. Use and maintenance are the responsibility of the customer. The manufacturer cannot assume responsibility for conditions over which it has no control. Simply put, if it's the manufacturer's fault, it's the manufacturer's responsibility; if it's the customer's fault, it's the customer's responsibility.

CLAIMS AGAINST THE MANUFACTURER'S WARRANTY INCLUDES:

1. Replacement of Missing Parts on new equipment.
2. Replacement of Defective Parts within the warranty period.
3. Repair of Defects within the warranty period.

All claims MUST be substantiated with the following information:

1. Model Number of unit involved.
2. Date unit was purchased or first put into service.
3. Date of failure—Date Repaired.
4. Nature of failure—Correction.

YARD-MAN COMPANY • P.O. BOX 36940 • CLEVELAND, OHIO 44136