

YARD-MAN

OUTDOOR POWER EQUIPMENT
for all seasons



Spring



Summer



Fall



Winter

Owner's Manual

- ASSEMBLY
- OPERATION
- MAINTENANCE
- PARTS LIST

IMPORTANT:
Read Safety Rules and
Instructions Carefully

Thank you for purchasing
an American-built product.

12 H.P. LAWN TRACTOR (4 Wheel Steer)

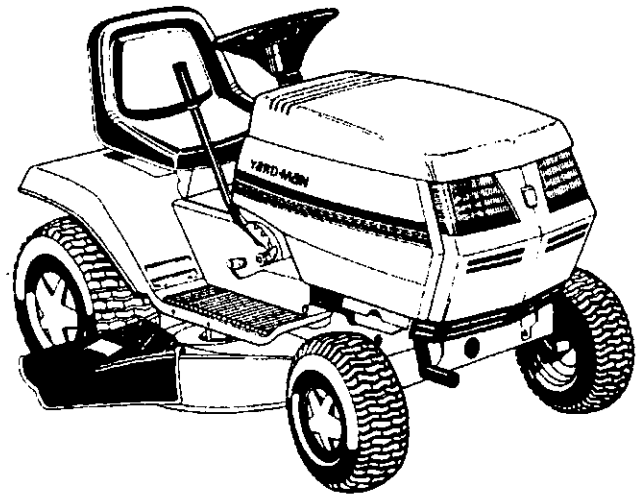

Model Number 130754F

INDEX

Slope Gauge	3
Contents of Hardware Pack	4
Rules for Safe Operation	5
Assembly Instructions	6
Controls	10
Operation	11
Adjustments	13
Lubrication	15
Maintenance	16
Off-Season Storage	18
Trouble Shooting Guide	19, 20
Illustrated Parts for Lawn Tractor	21-29
Illustrated Parts for Transaxle	30, 31
Parts Information	Back Cover

Dear Customer,

So often throughout the year we are all in a rush to meet our daily obligations.

However, we at YARD-MAN COMPANY are taking a quick moment out to say...

"Thank you for your business."

Sincerely,
YARD-MAN COMPANY



INSTRUCTIONS GIVEN WITH THIS SYMBOL ARE FOR PERSONAL SAFETY. BE SURE TO FOLLOW THEM.

TWO YEAR LIMITED WARRANTY

For two years from the date of original retail purchase, YARD-MAN COMPANY will either repair or replace, at its option, free of charge, F.O.B. factory or authorized service firm, any part or parts found to be defective in material or workmanship. Transportation charges for the movement of any power equipment unit or attachment are the responsibility of the purchaser. Transportation charges for any parts submitted for replacement under this warranty must be paid by the purchaser unless such return is requested by YARD-MAN COMPANY.

This warranty will not apply to any part which has become inoperative due to misuse, excessive use, accident, neglect, improper maintenance, alterations, or if the unit has not been operated and maintained in accordance with the instructions furnished. This warranty does not apply to the engine, Peerless components, motor, battery (except as noted below) or component parts thereof. Please refer to the applicable manufacturer's warranty on these items.

A battery which proves defective within ninety (90) days will be replaced without charge. After 90 days but within one hundred twenty (120) days of purchase, YARD-MAN COMPANY will replace the defective battery for a charge of 1/2 of the current retail price of the battery in effect at the date of return.

Warranty on units used commercially is limited to sixty (60) days.

Warranty service is available through your local authorized service dealer or distributor. If you do not know the dealer or distributor in your area, please write to the Customer Service Department of YARD-MAN.

The return of a complete unit will not be accepted by the factory unless prior written permission has been extended by YARD-MAN.

This express limited warranty is in lieu of all other warranties, express or implied, including any implied warranty of merchantability. The remedy of replacement is the sole and exclusive remedy for YARD-MAN obligations arising from the sale of its products. In no case will YARD-MAN be liable for incidental or consequential loss or damage.

This warranty gives you specific legal rights. You may also have other rights which vary from state to state.

WARNING: This unit is equipped with an internal combustion engine and should not be used on or near any unimproved forest-covered, brush-covered or grass-covered land unless the engine's exhaust system is equipped with a spark arrester meeting applicable local or state laws (if any). If a spark arrester is used, it should be maintained in effective working order by the operator.

In the State of California the above is required by law (Section 4442 of the California Public Resources Code). Other states may have similar laws. Federal laws apply on federal lands. A spark arrester for the muffler is available through your nearest engine authorized service dealer or contact the customer service department of YARD-MAN COMPANY.

SLOPE GAUGE

(Keep this sheet in a safe place for future reference.)

USE THIS SHEET AS A GUIDE TO DETERMINE SLOPES WHERE YOU MAY NOT OPERATE SAFELY.

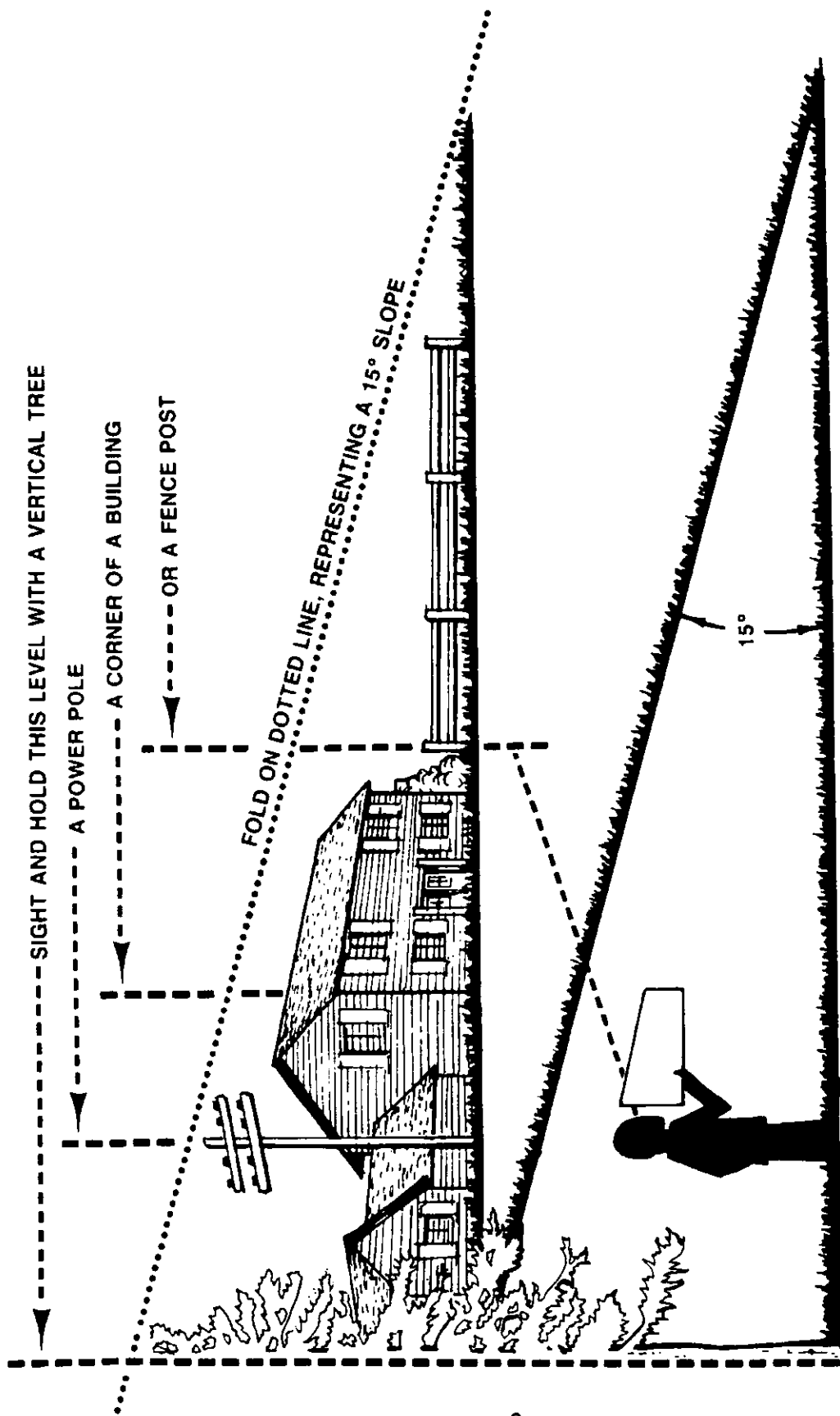

Do not mow on inclines with a slope in excess of 15 degrees (a rise of approximately 2½ feet every 10 feet). A riding mower could overturn and cause serious injury. If operating a walk-behind mower on such a slope, it is extremely difficult to maintain your footing and you could slip, resulting in serious injury.

Operate RIDING mowers up and down slopes, never across the face of slopes.

Operate WALK-BEHIND mowers across the face of slopes, never up and down slopes.

CONTENTS OF HARDWARE PACK

Remove this sheet from your owner's manual and lay the hardware on the illustration for identification purposes. After assembly, keep the Slope Gauge which is on the reverse side of this sheet for future use.

(Hardware pack may contain extra items which are not used on your unit.)

A INSTALLING THE BATTERY

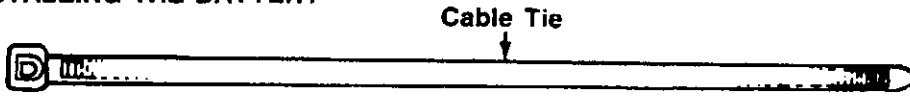

B ATTACHING THE STEERING WHEEL

(Steering Wheel Insert is Not Shown)

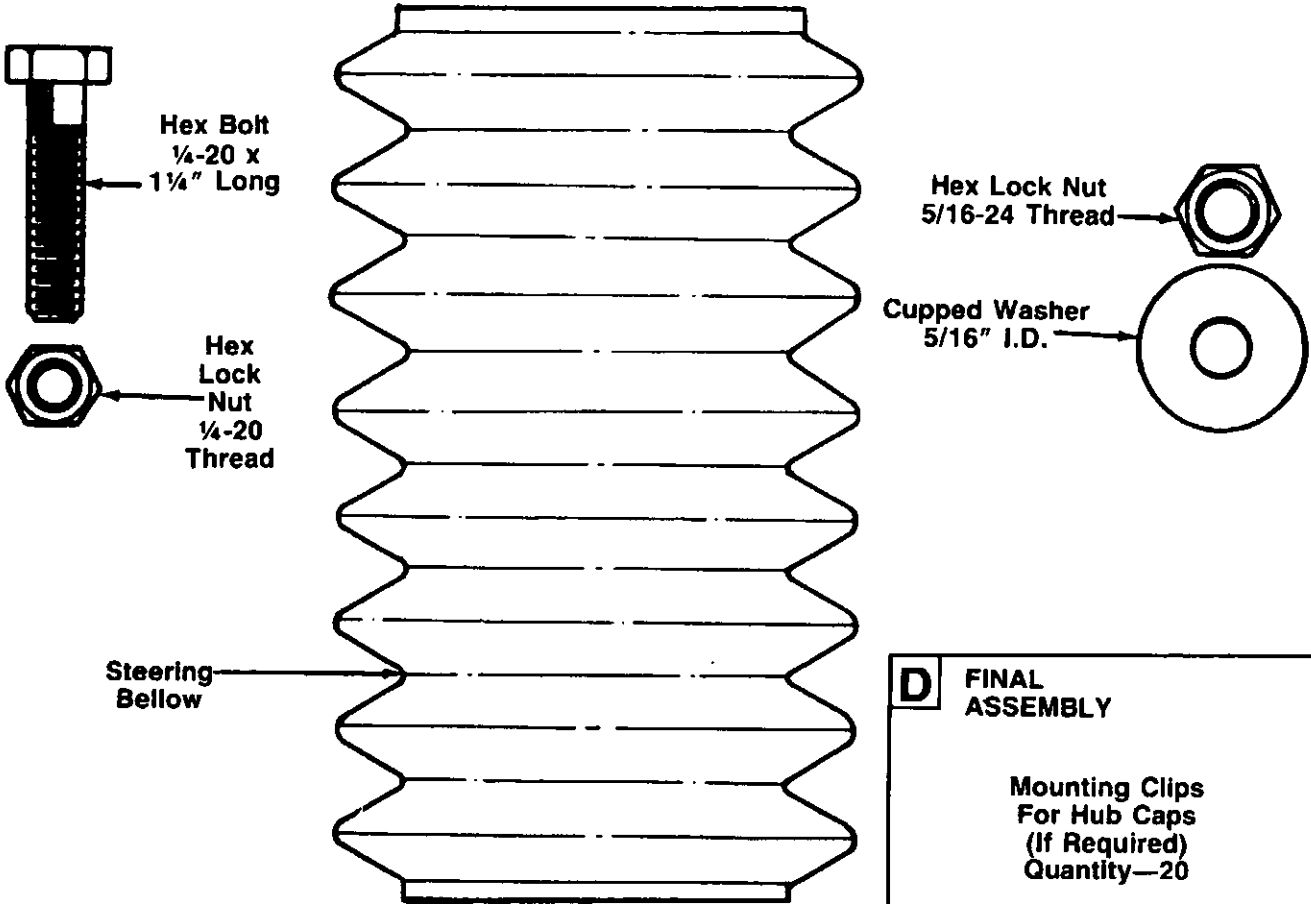

C ATTACHING THE SEAT

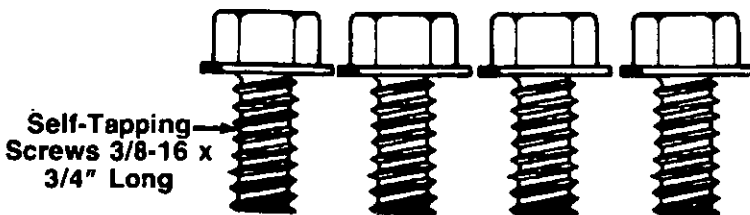

E IGNITION KEYS

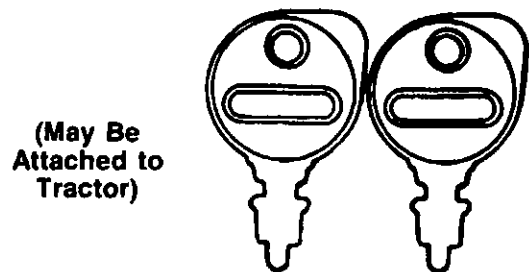

INCHES

4

Cut Along this Line

IMPORTANT

RULES FOR SAFE OPERATION



THIS SYMBOL POINTS OUT IMPORTANT SAFETY INSTRUCTIONS WHICH, IF NOT FOLLOWED, COULD ENDANGER THE PERSONAL SAFETY AND/OR PROPERTY OF YOURSELF AND OTHERS. READ AND FOLLOW ALL INSTRUCTIONS IN THIS MANUAL BEFORE ATTEMPTING TO OPERATE YOUR UNIT. FAILURE TO COMPLY WITH THESE INSTRUCTIONS MAY RESULT IN PERSONAL INJURY. WHEN YOU SEE THIS SYMBOL—



HEED ITS WARNING.



DANGER

Your unit was built to be operated according to the rules for safe operation in this manual. As with any type of power equipment, carelessness or error on the part of the operator can result in serious injury. If you violate any of these rules, you may cause serious injury to yourself or others.

1. READ THIS OWNER'S MANUAL carefully in its entirety before attempting to assemble or operate this unit. Keep this manual in a safe place for future and regular reference and for ordering replacement parts.
2. This unit is a precision piece of power equipment, not a plaything. Therefore exercise extreme caution at all times.
3. Know the controls and how to stop the machine quickly.
4. Do not allow children to operate vehicle. Do not allow adults to operate it without proper instruction. Only persons well acquainted with these rules of safe operation should be allowed to use your mower.
5. Wear sturdy, rough-soled work shoes and close-fitting slacks and shirts to avoid entanglement in the moving parts. Never operate a unit in bare feet, sandals, or sneakers.
6. To prevent injury, do not carry passengers or give rides. Keep children, pets and bystanders out of the area while mowing. Only the operator should ride on the unit and only ride in the seat.
7. Check overhead clearance carefully before driving under power lines, guy wires, bridges or low hanging tree branches, before entering or leaving buildings, or in any other situation where the operator may be struck or pulled from the unit, which could result in serious injury.
8. To maintain control of the unit and reduce the possibility of upset or collision, operate the tractor smoothly. Avoid erratic operation and excessive speed.
9. Keep the area of operation clear of all persons, particularly small children and pets. Stop engine when they are in the vicinity of your mower. Although the area of operation should be completely cleared of foreign objects, a small object may have been overlooked and could be accidentally thrown by the mower in any direction and cause injury to you or a bystander.
10. Always wear safety glasses or eye shields during operation or while performing an adjustment or repair, to protect eyes from foreign objects that may be thrown from the machine in any direction.
11. Stop the blade(s) when crossing gravel drives, walks or roads.
12. Disengage all attachment clutches and shift into neutral before attempting to start engine.
13. Before leaving the operator's position, disengage blade(s), place shift lever in neutral, engage parking brake, shut engine off and remove key.
14. Do not put hands or feet near or under rotating parts. Keep clear of the discharge opening at all times as the rotating blade(s) can cause injury.
15. Disengage power to attachment(s) and stop engine before making any repairs or adjustments. Disconnect the spark plug wire and keep the wire away from the plug to prevent accidental starting.
16. Before attempting to unclog the mower or discharge chute, stop the engine. The mower blade(s) may continue to rotate for a few seconds after the engine is shut off. Therefore, be sure the blade(s) have stopped completely. Disconnect the spark plug wire and keep the wire away from the plug to prevent accidental starting.
17. Disengage power to attachment(s) when transporting or not in use.
18. For your safety, use the slope gauge included as part of this manual to measure slopes before operating this unit on a sloped or hilly area. If the slope is greater than 15° as shown on the slope gauge, do not operate this unit on that area or serious injury could result.
19. Do not stop or start suddenly when going uphill or downhill. Mow up and down face of steep slopes; never across the face. Use extreme caution if it is necessary to drive the tractor up an incline or back the tractor down an incline because the front of the tractor could lift and rapidly flip over backward which could cause serious injury.
20. Reduce speed on slopes and in sharp turns to prevent tipping or loss of control. Always keep the tractor in low gear when going down steep hills to take advantage of engine braking action. Choose a low enough gear so that you will not have to stop or shift while on the slope.
21. Stay alert for holes in terrain and other hidden hazards which may cause the unit to tip over.
22. Use care when pulling loads or using heavy equipment.
 - A. Use only approved drawbar hitch points.
 - B. Limit loads to those you can safely control.
 - C. Do not turn sharply. Use care when backing.
 - D. Use counterweight(s) or wheel weights when suggested in owner's manual.
23. Watch out for traffic when crossing or near roadways.
24. When using any attachments, never direct discharge of material toward bystanders nor allow anyone near vehicle while in operation.
25. Handle gasoline with care. It is highly flammable.
 - A. Use approved gasoline container.
 - B. Never remove cap or add gasoline to a running or hot engine or fill fuel tank indoors. Wipe up spilled gasoline. Always use original type vented cap.
 - C. Open doors if engine is run in garage. Exhaust fumes are dangerous. Do not run engine indoors.
26. Never store the machine with fuel in the fuel tank inside a building where ignition sources are present, such as hot water and space heaters, clothes dryers, and the like. Allow the engine to cool before storing in any enclosure.
27. To reduce fire hazard, keep engine and cutting deck free of grass, leaves or excessive grease.
28. Keep the vehicle and attachments in good operating condition, and keep safety devices in place. Use guards as instructed in operator's manual.
29. Keep all nuts, bolts, and screws tight to be sure the equipment is in safe working condition.
30. The vehicle and attachments should be stopped and inspected for damage after striking a foreign object. The damage should be repaired before restarting and operating the equipment.
31. Do not change the engine governor settings or overspeed the engine.

Rules for Safe Operation (continued)

32. When using the vehicle with mower, proceed as follows:
 - (1) Mow only in daylight or in good artificial light.
 - (2) Never make a cutting height adjustment while engine is running if operator must dismount to do so.
- (3) Shut the engine off and wait until the blade comes to a complete stop before removing the grass catcher.
- (4) Check blade mounting bolts for proper tightness at frequent intervals.
33. Check grass catcher bags frequently for wear or deterioration. For safety protection, replace only with new bag meeting original equipment specifications.
34. Look behind to make sure the area is clear before placing the transmission in reverse and continue looking behind while backing up. Disengage blades before shifting into reverse and backing up.
35. This unit should not be driven up a ramp onto a trailer or truck under power, because the unit could tip over, causing serious personal injury. The unit must be pushed manually to load properly.
36. Check brake operation frequently. Adjust and service according to brake adjustment instructions in this manual.

ASSEMBLY

IMPORTANT: This unit is shipped **WITHOUT GASOLINE or OIL**; however, a small amount of oil may be present from the factory. Do not overfill. After assembly, service engine with gasoline and oil as instructed in the separate engine manual packed with your unit.

Refer to the separate deck manual for all information concerning the deck.

NOTE: Reference to right or left hand side of the unit is observed from the driver's seat, facing forward.

UNPACKING

1. Remove the lawn tractor from the carton as follows. Open the top flaps. Remove all loose parts and carton inserts. Cut the front corners of the carton. Make certain brake is released, and push the unit out of the carton.
2. Remove page four from this manual and lay the contents of the hardware pack on the illustration for identification.

BATTERY INFORMATION



WARNING

- A. Battery acid must be handled with great care as contact with it can burn and blister the skin. It is also advisable to wear protective clothing (goggles, rubber gloves and apron) when working with it.*
- B. Should battery acid accidentally splatter into the eyes or onto the face, rinse the affected area immediately with clean cold water. If there is any further discomfort, seek prompt medical attention.
- C. If acid spills on clothing, first dilute it with clean water, then neutralize with a solution of ammonia/water or baking soda/water.
- D. Since battery acid is corrosive, do not pour it into any sink or drain. Before discarding empty electrolyte containers, rinse them with a neutralizing solution.
- E. NEVER connect or disconnect charger clips to battery while charger is turned on as it can cause sparks.
- F. Keep all lighted materials (cigarettes, matches, lighters) away from the battery as the hydrogen gas generated during charging can be combustible.
- G. As a further precaution, only charge the battery in a well-ventilated area.

*Always shield eyes, protect skin and clothing when working near batteries.

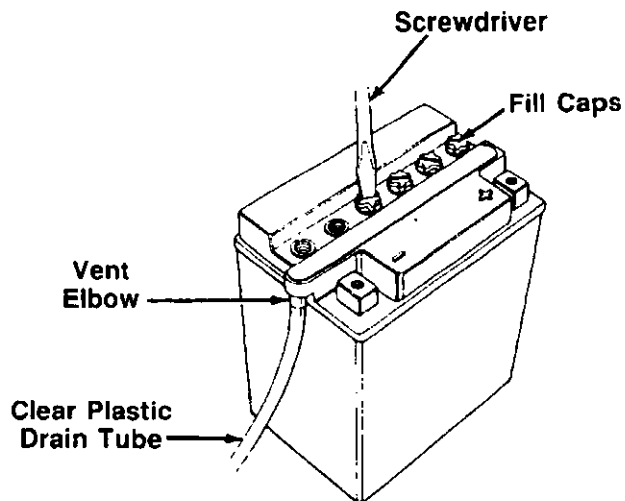

FIGURE 1.

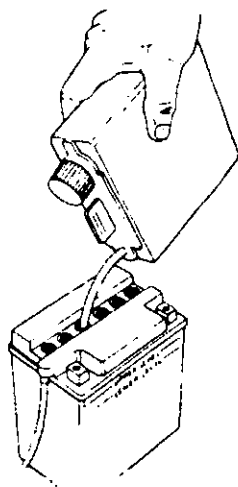

FIGURE 2.

ACTIVATING THE BATTERY

Do not activate battery (fill with battery acid) until battery is actually placed in service. Be certain to read previous warnings before activating the battery.

1. Open the battery pack. Be careful not to puncture the box. It contains the battery with a long plastic tube attached, battery fluid (acid) in a plastic container, one short plastic tube and one hardware pack (two hex bolts and nuts).
2. Place the battery on a table or workbench. Make certain the long plastic drain tube is in place on the vent elbow.
3. Remove the six fill caps from the top of the battery with a screwdriver. Be careful not to damage the fill caps. See figure 1.
4. Place the battery fluid container on the table or workbench. Carefully cut off tip of the spout and attach the short plastic tube provided. Do not squeeze the container when cutting tip.
5. Fill each battery cell slowly and carefully to the UPPER LEVEL line marked on battery. See figure 2. Use caution as the acid level will rise rapidly after the bottom of the cell is filled.
6. Allow battery to stand for 30 minutes with the fill caps removed, while the plates absorb acid.
7. If acid level has fallen after the 30 minute standing period, refill each cell with battery acid to the UPPER LEVEL line on battery. Replace the fill caps.
8. Before discarding the empty container, neutralize any residue with baking soda and rinse container with water. Puncture container several times before discarding.
9. Charge the battery after the 30 minute standing period. SLOW CHARGE THE BATTERY (DO NOT FAST CHARGE) at a maximum bench rate of 1.4 amperes until the specific gravity reading is 1.260-1.280. Charge for a minimum of 2 hours and a maximum of 8 hours.



DANGER

Battery contains sulfuric acid. Refer to warning on page 6. Antidote: EXTERNAL—Flush with water. INTERNAL—Drink large quantities of water or milk. Follow with milk of magnesia, beaten eggs or vegetable oil. Call physician immediately. EYES: Flush with cool water for at least 15 minutes, then get prompt medical attention.

Since batteries produce explosive gases, keep all lighted materials (cigarettes, lighters, matches, etc.) away. Be sure to charge battery only in well-ventilated areas. Make certain venting path of battery (drain tube) is always open.

KEEP BATTERIES
OUT OF THE REACH OF CHILDREN!

NOTE: This engine is equipped with an alternator. The current for the battery charger alternator is unregulated. During normal operation, it is only necessary to charge the battery:

1. When it is activated for the first time.
2. Before winter storage.
3. Before using the lawn tractor after winter storage.

NOTE: Charging rate after battery has been put into operation—the battery is to be charged for a period of 14-16 hours. NO LONGER THAN 30 HOURS.

After battery has been charged, add only distilled water. Do not add acid.

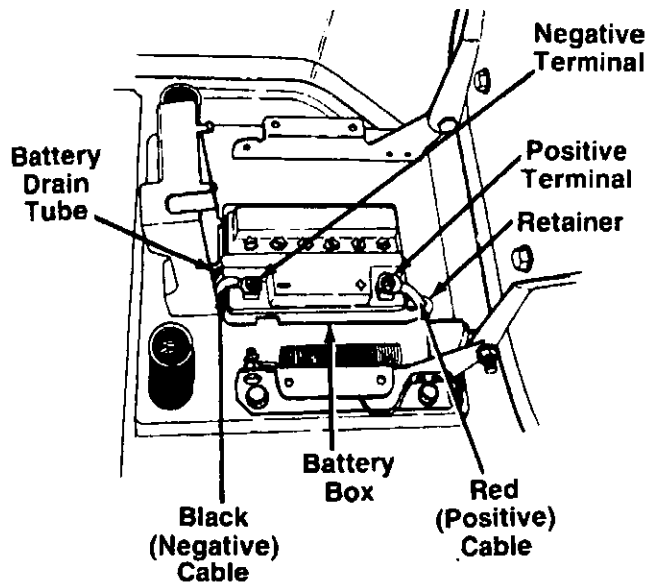

FIGURE 3.

INSTALLING THE BATTERY (Hardware A)

1. Raise the seat bracket (on top of the fender).
2. Make certain the positive cable (heavy red wire) extends through the retainer on the front of the battery box. The negative cable (heavy black wire) should be routed up along the back of the battery box.
3. Place the battery inside the battery box so that the positive terminal is toward the front of the unit. See figure 3. Route the battery drain tube down beside the battery box.
4. Slide the hex nut (provided with battery hardware) into the positive (+) terminal. Place the positive cable on the positive terminal. Secure with bolt provided. See figure 3.
5. Slide the hex nut (provided with battery hardware) into the negative (-) terminal. Place the negative cable on the negative terminal. Secure with bolt provided.

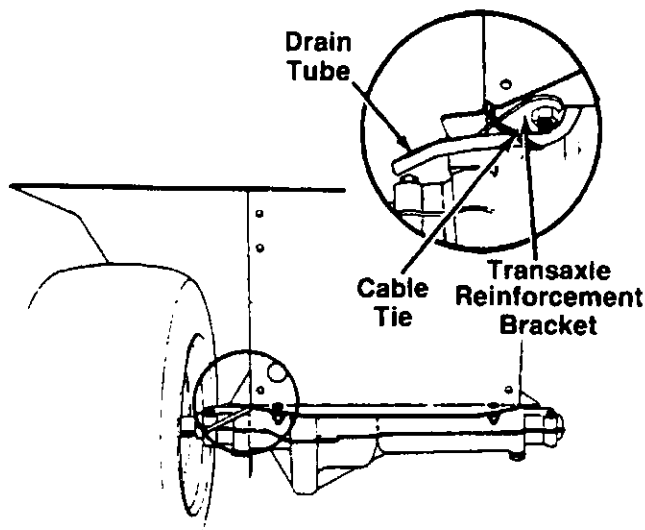

FIGURE 4.

6. Secure the drain tube to the transaxle reinforcement bracket on the left side of the unit, using the cable tie as shown in figure 4. Be certain drain tube is routed away from the wheel rim. Trim excess end of cable tie.
7. Close the top of the battery box and lower the seat.

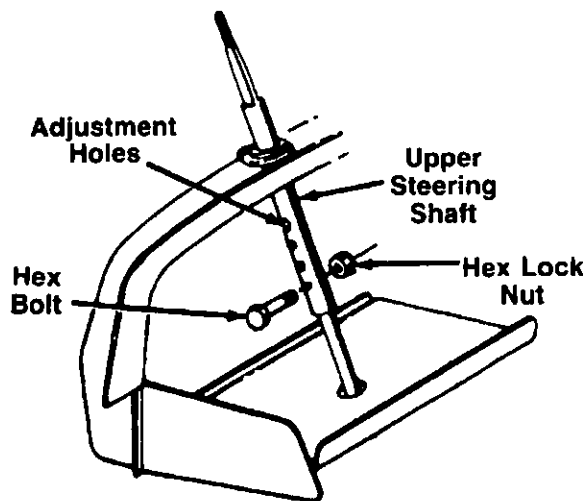

FIGURE 5.

ATTACHING THE STEERING WHEEL (Hardware B)

1. Open the hood of the lawn tractor by lifting up on the hood.
2. If not already assembled, insert large end of the upper steering shaft through the hole in the dash panel, over the lower steering shaft. See figure 5. The four holes in the upper steering shaft provide four steering wheel heights. Select desired hole, and secure with hex bolt and hex lock nut.

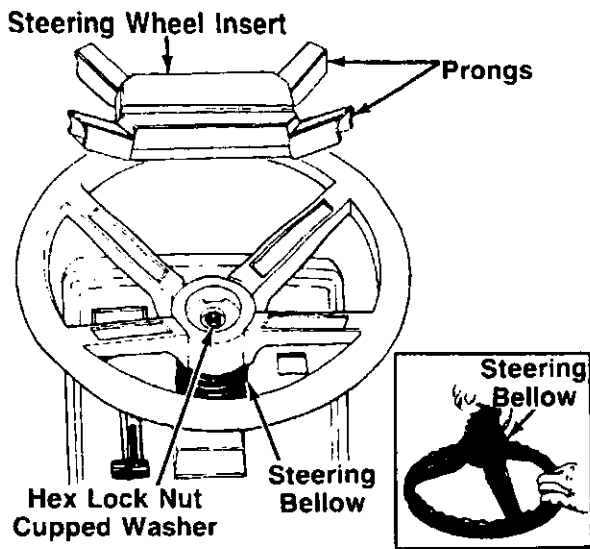

FIGURE 6.

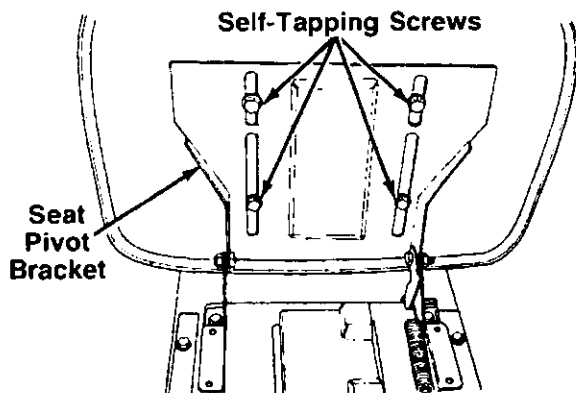

FIGURE 7.

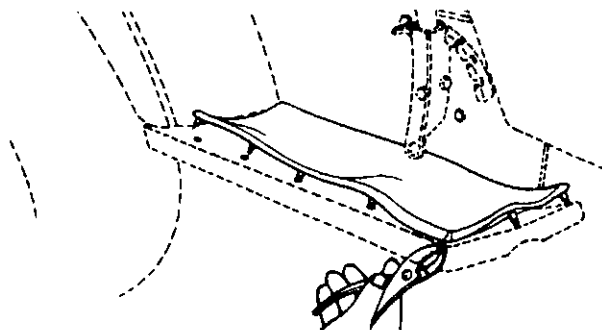

FIGURE 8.

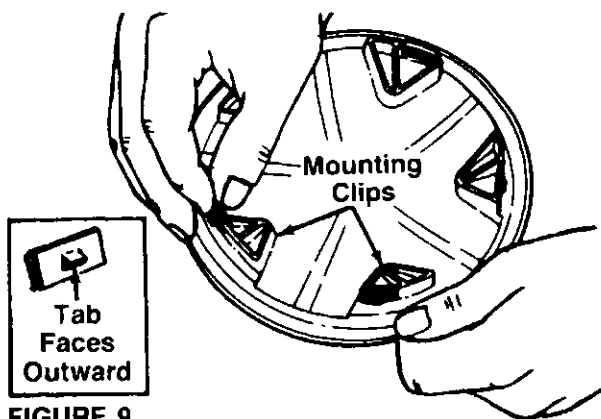

FIGURE 9.

3. Attach one end of steering bellow to the steering wheel as shown in figure 6, inset.
4. Position the front wheels of the tractor so they are pointing straight forward.
5. Place the steering wheel and steering bellow over the steering shaft, positioning steering wheel as shown.
6. Place the washer with the cupped side down over the steering shaft. Secure with 5/16" hex lock nut. See figure 6.
7. Attach the steering wheel insert to the steering wheel as follows.
 - A. Place the two prongs on one side of the insert over two of the spokes on the steering wheel. Press into place.
 - B. Press the prongs on the other side of the insert over the other two spokes on the steering wheel.

ATTACHING THE SEAT (Hardware C)

Place the seat in position against the seat pivot bracket, lining up the slotted holes in the pivot bracket with the holes in the seat. Select desired position for the seat, and secure with hex self-tapping screws. See figure 7.

ATTACHING THE CHUTE DEFLECTOR

If your unit has been shipped without the chute deflector assembled, follow the instructions in the separate deck manual packed with your unit.



WARNING: Do not operate your unit unless the chute deflector has been properly installed.

FINAL ASSEMBLY (Hardware D)

1. If not already assembled, attach the foot pads as follows. Position one foot pad on top of the running board on the tractor, lining up the studs on the bottom of pad with the holes in the running board. Pull the studs through the holes in the running board using a pair of pliers. Repeat on other side of tractor. See figure 8.
2. If not already assembled, attach the four hub caps as follows.
 - a. Slide five mounting clips on each hub cap as shown in figure 9, with the tabs on the mounting clips facing outward.
 - b. Line up hub caps with wheel rims. Push hub caps on by hand.

TIRE PRESSURE

The tires on your unit may be over-inflated for shipping purposes. Reduce the tire pressure before operating the unit. Recommended operating tire pressure is approximately 12 p.s.i. (check sidewall of tire for tire manufacturer's recommended pressure).



WARNING: Maximum tire pressure under any circumstances is 30 p.s.i. Equal tire pressure should be maintained on all tires.

CONTROLS

IGNITION SWITCH

The ignition switch is located on the dashboard. Turn the key to the START position to start the engine. When the engine is running, leave the key in the ON position. To stop the engine, turn the key to the OFF position. See figure 10.



WARNING: Remove the key from the tractor when the tractor is not in use to prevent accidental starting.

THROTTLE CONTROL

The throttle control is located on the left side of the dashboard and is used to regulate the engine speed. See figure 10. The engine should be operated at full throttle (FAST) when operating the mower.

CHOKE CONTROL

The choke control is located on the right side of the dashboard and is operated manually. Details for the choke operation are covered in the separate engine manual packed with your unit. See figure 10.

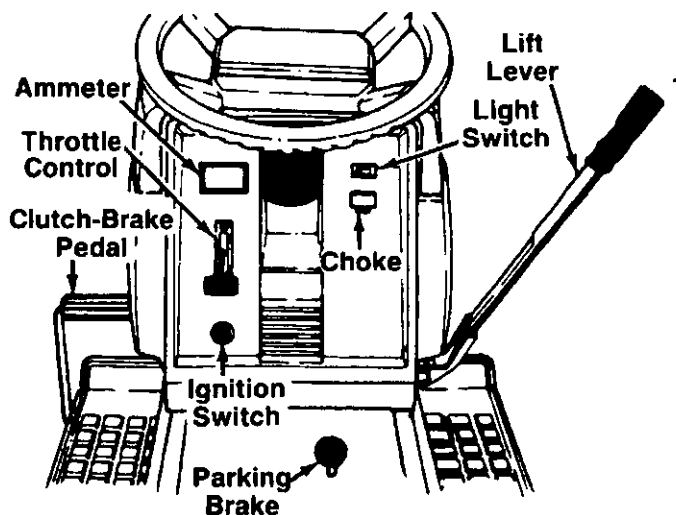

FIGURE 10.

LIGHT SWITCH

The head lamps are operated by pushing the light switch located on the dashboard. The head lamps will only operate when the engine is running. See figure 10.

AMMETER

The ammeter registers the rate of battery charge or discharge. The ammeter will register on the discharging side when starting the engine. It should register on the opposite side (charging) when the engine is running in the fast position until the battery is completely charged. With a fully charged battery or with the engine idling, the ammeter will not show a charge. See figure 10.

CLUTCH-BRAKE PEDAL

The clutch-brake pedal is located on the left side of the tractor. See figure 10. Depressing the clutch-brake pedal partway disengages the clutch. Pressing the pedal all the way down disengages the clutch and engages the disc brake.

NOTE: The clutch-brake pedal must be depressed to start the engine.

SHIFT LEVER

The shift lever is located on the right fender and has three positions, FORWARD, NEUTRAL and REVERSE. See figure 11. The clutch-brake pedal must be depressed and the lawn tractor must not be moving when shifting gears. Do not force the shift lever. Release the clutch-brake pedal slightly to line up the shifting collar in the transmission. Then try to shift gears.

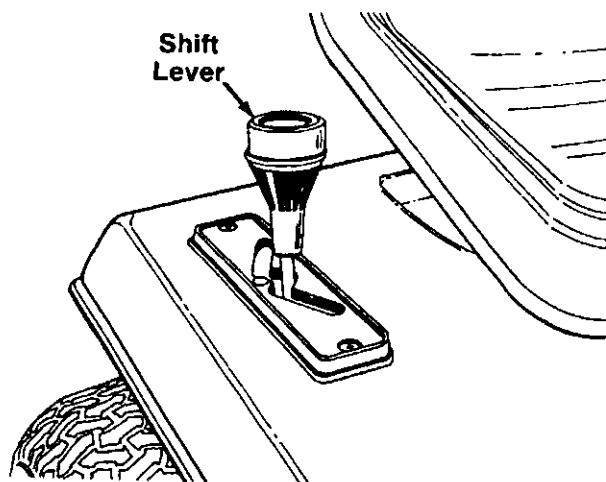

FIGURE 11.

PARKING BRAKE

To set the parking brake, depress the clutch-brake pedal and pull up the parking brake knob. It will stay in the raised position. To release the parking brake, depress and release the clutch-brake pedal. See figure 10.

NOTE: The parking brake must be set if the operator leaves the seat with the engine running.

SPEED CONTROL LEVER

The speed control lever is located on the left fender. It allows you to regulate the ground speed of the lawn tractor. See figure 12. To select the ground speed, depress clutch pedal. Push speed control lever outward and move backward to slow lawn tractor, move forward to increase speed. When desired speed has been obtained, release lever in that position. Whenever clutch is engaged, unit will automatically go to the pre-set speed.

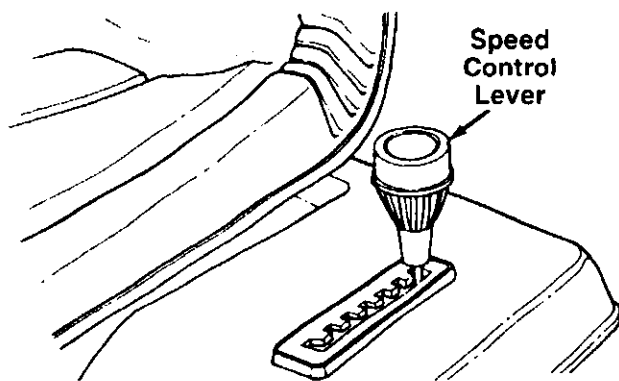

FIGURE 12.

CUTTING CONTROLS

A. LIFT LEVER

The lift lever is used to raise and lower the cutting deck and to engage and disengage the blades. Pulling it all the way back and locking it disengages the blades.

NOTE: The lift lever must be in the disengaged position when starting the engine, when shifting into reverse or if the operator leaves the seat.

B. DECK LIFT INDICATOR

The deck lift indicator marks the position being used for the lift lever. Select the lift lever position desired,

press the indicator lever outward, move it to the position immediately below the lift lever and release the indicator lever. See figure 13.

C. SETTING THE CUTTING HEIGHT

1. Select the position for the lift lever which gives the desired cutting height. Move the deck lift indicator so that the lift lever can be returned to the same position after it is raised.
2. Move the deck wheels to the hole location so the wheels are $\frac{1}{4}$ to $\frac{1}{2}$ inch above the ground.

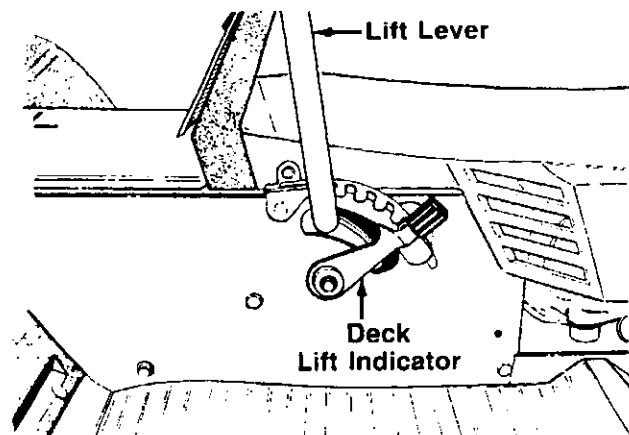

FIGURE 13.

OPERATION

CAUTION

- READ OPERATOR'S MANUAL(S) • NEVER CARRY CHILDREN
- KNOW LOCATION AND FUNCTION OF ALL CONTROLS
- KEEP SAFETY DEVICES (GUARDS, SHIELDS AND SWITCHES) IN PLACE AND WORKING
- REMOVE OBJECTS THAT COULD BE THROWN BY BLADE(S)
- DO NOT OPERATE THE UNIT WHEN CHILDREN AND OTHERS ARE AROUND
- ALWAYS LOOK BEHIND THE UNIT BEFORE BACKING UP
- DO NOT OPERATE THE UNIT WHERE IT COULD SLIP OR TIP
- IF THE UNIT STOPS GOING UPHILL, STOP BLADE(S) AND BACK SLOWLY DOWNHILL
- BE SURE BLADE(S) AND ENGINE ARE STOPPED BEFORE PLACING HANDS OR FEET NEAR BLADE(S)
- BEFORE LEAVING OPERATOR'S POSITION, DISENGAGE THE BLADE(S), PLACE THE SHIFT LEVER IN NEUTRAL, ENGAGE THE PARKING BRAKE, SHUT ENGINE OFF AND REMOVE THE KEY.

GAS AND OIL FILL-UP

Service the engine with gasoline and oil as instructed in the separate engine manual packed with your lawn tractor. Read instructions carefully.

NOTE: Your lawn tractor is shipped without oil; however, a small amount of oil may be present from the factory. Do not overfill.



WARNING: Never fill fuel tank indoors, with engine running or while engine is hot.

STARTING THE ENGINE

IMPORTANT: This unit is equipped with a safety interlock system for your protection. The purpose of the safety interlock system is to prevent the engine from cranking or starting unless the clutch-brake pedal is depressed and the lift lever is in the disengaged position. In addition, the lift lever must be in the disengaged position when the unit is put into reverse or the engine will shut off. If the operator leaves the seat with the lift lever engaged and/or without setting the parking brake, the engine will shut off.



WARNING: Do not operate the lawn tractor if the interlock system is malfunctioning because it is a safety device, designed for protection.

1. Place the lift lever in the DISENGAGED position.
2. Depress the clutch-brake pedal and set the parking brake.
3. Place the shift lever in the NEUTRAL position.
4. Set the throttle control in the FAST position.
5. Pull out the choke control (a warm engine may not require choking).
6. Turn the ignition key to the right to the START position. After the engine starts, release the key. It will return to the ON position.
7. Slowly push in the choke as the engine warms up.

STOPPING THE ENGINE

Turn the ignition key to the left to the OFF position. Remove the key to prevent accidental starting.

IMPORTANT: If you strike a foreign object, stop the engine. Remove wire from spark plug, thoroughly inspect the unit for any damage, and repair the damage before restarting and operating the mower.

NOTE: If any problems are encountered, refer to the Trouble Shooting Chart on page 19.

OPERATING THE LAWN TRACTOR



WARNING: Before operating your four wheel steer lawn tractor, be certain to read the next section, "Steering the Lawn Tractor." Operate your tractor in an open area when operating for the first time.

1. Set the desired cutting height.
2. Start the engine as instructed previously.
3. Move throttle control to full throttle to prevent strain on the engine and to operate attachments.
4. Place the shift lever in either the FORWARD or REVERSE position. Place the speed control lever in desired position. Use first speed position when operating the tractor for the first time.



WARNING: Look to the rear before backing up.

5. Release the parking brake by depressing the clutch-brake pedal. Release clutch-brake pedal slowly to put unit into motion.
6. The lawn tractor is brought to a stop by depressing the clutch-brake pedal.

NOTE: When operating the unit initially, there will be little difference between the highest two speeds until after the belts have seated themselves into the pulleys during the break-in period.

Be sure that the lawn is clear of stones, sticks, wire, or other objects which could damage tractor or engine. For best results and to insure more even grass distribution, do not mow when lawn is excessively wet.



WARNING: Before leaving the operator's position for any reason, disengage the blades, place the shift lever in neutral, engage the parking brake, shut engine off and remove the key.

When stopping the unit to empty a grass bag, etc., follow the instructions above. This procedure will also eliminate "browning" the grass, which is caused by hot exhaust gases from a running engine.

If unit stalls with speed control in high speed, or if unit will not operate with speed control lever in a low speed position, proceed as follows.

1. Place shift lever in NEUTRAL.
2. Restart engine.
3. Place speed control lever in HIGH speed position.
4. Release clutch-brake pedal fully.
5. Depress clutch-brake pedal.
6. Place speed control lever in desired position.
7. Place shift lever in either FORWARD or REVERSE, and follow normal operating procedures.

STEERING THE LAWN TRACTOR

Your four wheel steering lawn tractor is designed for optimum maneuverability. It is important to understand how it operates before using the lawn tractor.

If the wheels are pointing straight forward and the steering wheel is turned less than approximately 45°, only the front wheels turn. See figure 14A. When the steering wheel is turned sharply (more than approximately 45°), the rear wheels also turn, but in the opposite direction as the front wheels to provide a very small turning radius. See figure 14B.

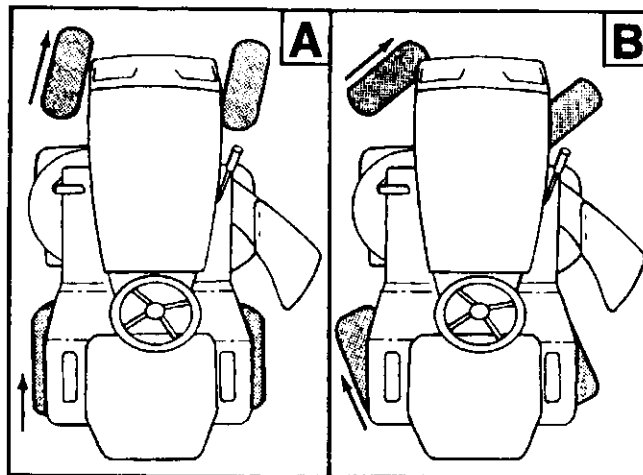
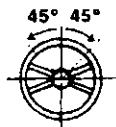

FIGURE 14.

The important point is this: When operating the lawn tractor beside a wall or fence, against or on top of a curb, driving around an object, or in any other similar situation, turn the steering wheel gradually to pull away from the object or curb so the rear of the tractor does not swing out and hit the object or go over the curb.



WARNING: If operating this lawn tractor near a drop-off in the ground, do not make a sharp turn. The rear wheel turns outward (see figure 14B) and could lose ground contact, which could cause the vehicle to tip over.

OPERATING THE CUTTING BLADES

The cutting blades may be engaged while the lawn tractor is moving or standing still. DO NOT engage the cutting blades abruptly as the sudden belt tension on the pulley may cause the engine to stall.



WARNING: Keep feet and hands away from the discharge opening, the blades or any part of the deck. When the unit is used for other than mowing operations, the blade drive should be disengaged.

Move the lift lever into the DISENGAGED position to raise the deck and disengage the blades.

GRASS COLLECTOR AVAILABLE

GRASS COLLECTOR Model 190063 is available as optional equipment.



WARNING: The mower should not be operated without the entire grass catcher or chute deflector in place.

NOTE: Under normal usage bag material is subject to wear, and should be checked periodically. Be sure any replacement bag complies with the mower manufacturer's recommendations. For replacement bags, use only factory authorized replacement bag.

ADJUSTMENTS

SEAT ADJUSTMENT

The seat may be adjusted to different positions. Refer to "Attaching the Seat" in assembly instructions.

STEERING WHEEL ADJUSTMENT

There are four height positions for the steering wheel. To adjust the height of the steering wheel, remove the hex bolt and hex lock nut on the steering shaft. Place the steering wheel in the position desired and secure with hex bolt and hex lock nut. Refer to figure 5.

NOTE: When raising the height of the steering wheel, stretch the steering bellow to cover the steering shaft.

DECK LEVELING ADJUSTMENT

If an uneven cut is obtained, the deck may be leveled as follows.

With unit on hard, level surface, measure the distance from the bottom edge of the center of the left side of deck to the ground. Measure the same distance on the center of the right side of the deck, just behind the chute area. Or, place the blades in a straight line, and measure the distance from the outside edge of the blade tips to the ground.

Adjust the lift link on the left side of the deck as necessary. See figure 15. Recheck the adjustment.

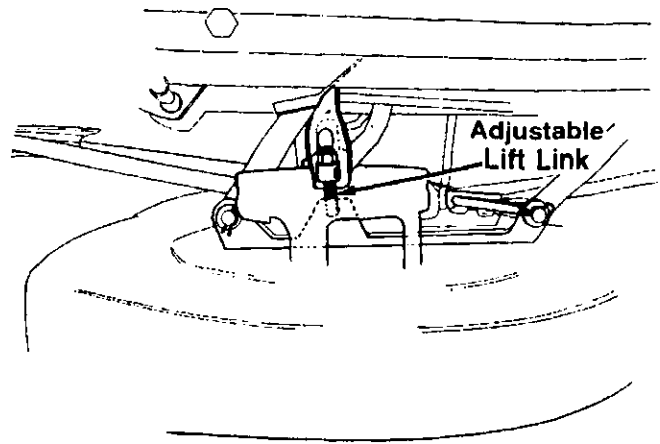

FIGURE 15.

SPEED CONTROL ADJUSTMENT

NOTE: When operating the unit initially or after replacing the belts, there will be little difference between the highest two speeds until after the belts have gone through a break-in period and have seated themselves into the pulleys.

To adjust the speed control, proceed as follows:

1. Start the engine.
2. Place the shift lever in Neutral position.
3. Place the speed control lever in high speed position.
4. Release the clutch-brake pedal completely, then slowly depress the pedal all the way (belt will be all the way to the outside of the bottom pulley). Hold the pedal in this position.
5. Turn the engine off.
6. After engine stops completely, release the clutch-brake pedal.
7. Unscrew the parking brake knob. Remove the transmission cover by removing two truss head screws.
8. Disconnect the speed selector rod from the variable speed pulley by removing the cotter pin and flat washer and lifting rod off the 3/8" pin. See figure 16.

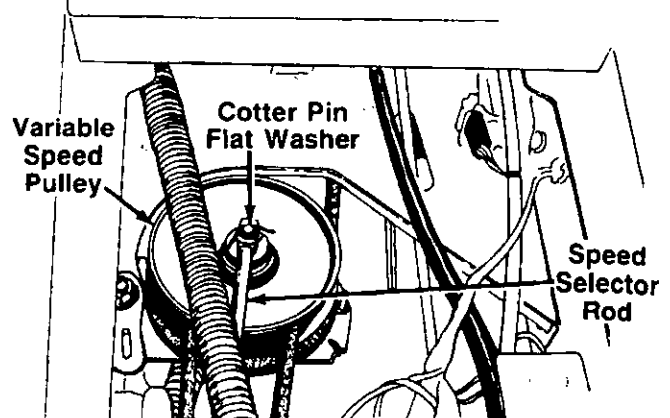

FIGURE 16.

- Disconnect the speed control link from the variable speed torque bracket by removing the cotter pin and flat washer. See figure 17.

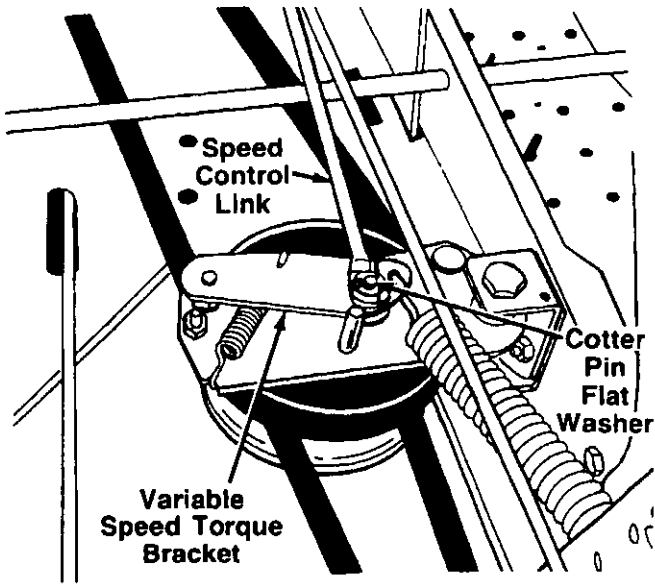

FIGURE 17.—Viewed From Beneath Tractor

- Place speed control lever in first speed position. Adjust speed selector rod as follows.
 - Push rod toward the rear of the tractor, against the end of the slot in the speed control lever assembly.
 - Turn rod into or out of the ferrule until it fits freely over the 3/8" pin on the variable speed pulley (turn clockwise to shorten rod, counterclockwise to lengthen rod).
 - After rod is adjusted to fit over pin, then turn rod **four (4) full turns counterclockwise**. Move speed control lever to second position. Attach rod to pin on variable speed torque bracket, using the flat washer and cotter pin.

- Adjust the brake by removing the cotter pin. Tighten the castle nut by hand until the brake lever locks against the bracket on the transaxle. See figure 18.

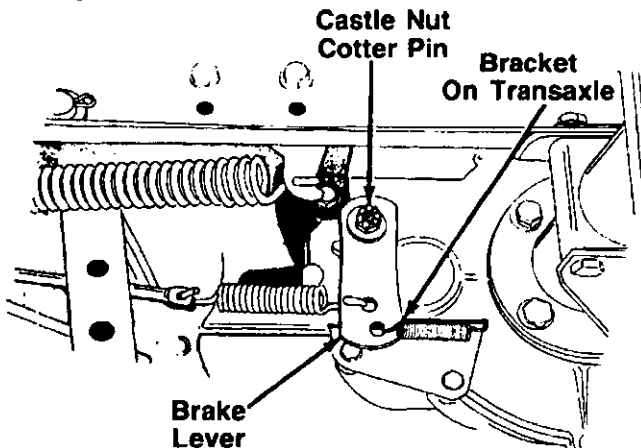

FIGURE 18.

- Push clutch-brake pedal forward until resistance is felt. Adjust the speed control link in or out until it fits over the pin on the torque bracket. Then shorten **two full turns**. Secure to pin on torque bracket using flat washer and cotter pin.
- Back the castle nut on the brake off 1 or 2 notches, till the hole in the brake mounting pin aligns with a slot in the castle nut. Secure with cotter pin.

WHEEL ADJUSTMENT

The caster (forward slant of the king pin) and the camber (tilt of the wheels out at the top) require no adjustment. Automotive steering principles have been used to determine the caster and camber on the tractor. The front wheels should toe-in 1/8 inch.

To adjust the toe-in, follow these steps.

- Remove the hex nut and lock washer, and drop the tie rod end from the axle bracket. See figure 19.
- Loosen the hex jam nut on tie rod.
- Adjust the tie rod assembly for correct toe-in.

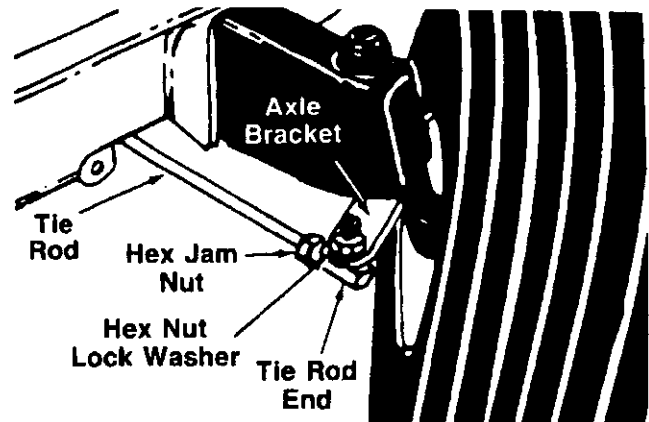

FIGURE 19.

Dimension "B" should be approximately 1/8" less than Dimension "A." See figure 20. To increase Dimension "B," screw tie rod into tie rod end. To decrease Dimension "B," unscrew tie rod from tie rod end. Reassemble tie rod. Check dimensions. Readjust if necessary.

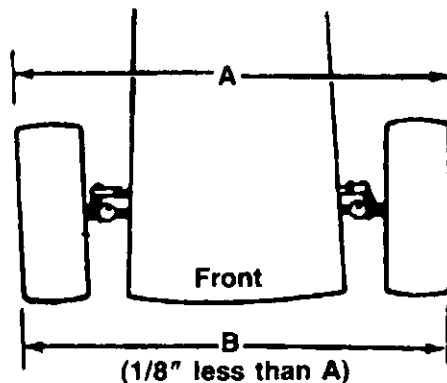

FIGURE 20.

If any further adjustment of the front or rear wheel steering mechanism is needed, the adjustment should be performed by your authorized service dealer.

CARBURETOR ADJUSTMENT



WARNING: If any adjustments are made to the engine while the engine is running (e.g. carburetor), disengage all clutches and blades. Keep clear of all moving parts. Be careful of heated surfaces and muffler.

Minor carburetor adjustment may be required to compensate for differences in fuel, temperature, altitude and load. To adjust the carburetor, refer to the separate engine manual packed with your unit.

NOTE: A dirty air cleaner will cause an engine to run rough. Be certain air cleaner is clean and attached to the carburetor before adjusting carburetor. Refer to the separate engine manual.

BRAKE ADJUSTMENT

During normal operation of this machine, the brake is subject to wear and will require periodic examination and adjustment.



WARNING: Do not have the engine running when you adjust the brake.

If brake adjustment is required, refer to step numbers 11, 12 and 13 of the Speed Control Adjustment section.

LUBRICATION



WARNING: Always stop engine and disconnect spark plug wire before cleaning, lubricating or doing any kind of work on lawn tractor.

FRONT WHEELS

The front wheels are provided with grease fittings. Lubricate front wheels at least once a season with automotive multi-purpose grease.

REAR WHEELS AND U-JOINTS

There are grease fittings provided on the rear wheel bearing housings and U-joints. Lubricate every 25 hours of operation using automotive multi-purpose grease. See figure 21. The rear tie rod ends have service-free inserts. **Do not** oil or grease the ball joints.

NOTE: Figure 21 is shown with rear wheel removed.

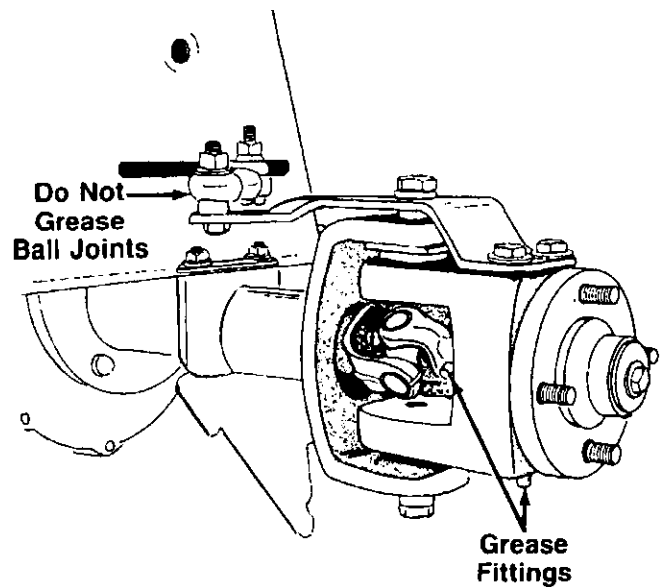

FIGURE 21.

STEERING GEARS

Lubricate teeth of the external steering gears with automotive multi-purpose grease after every 25 hours of operation or once a season. See figure 22.

The steering box assembly has a grease fitting. However, it should not require lubrication. If disassembled for any reason, lubricate with 4 oz. of #251 E.P. grease, part number 737-3007.

The steering shaft should be lubricated with light oil at least once a season.

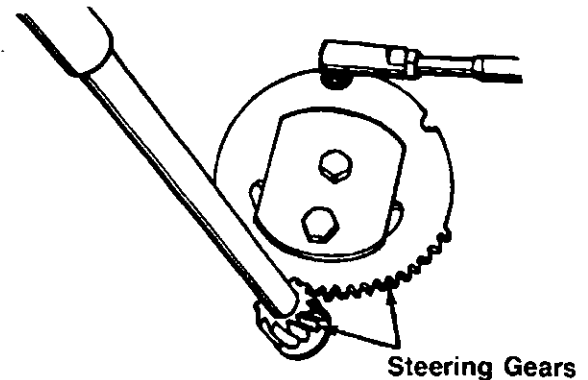

FIGURE 22.

TRANSAXLE

The transaxle is lubricated at the factory and does not require checking. If disassembled for any reason, lubricate with 32 oz. of Shell grease, part number 737-0148.

PIVOT POINTS

Lubricate all pivot points with light oil at least once a season.

MAINTENANCE



WARNING: Disconnect the spark plug wire and ground against the engine before performing any repairs or maintenance.

TROUBLE SHOOTING

Refer to page 19 of this manual for trouble shooting information.

CRANKCASE OIL

Check the oil level in the crankcase before each use of the machine and after every five hours of operation. Oil level should be maintained as instructed in the separate engine manual.

After the first five hours of operating a new engine, drain the oil from the crankcase while engine is still hot and refill crankcase with new oil; thereafter change the oil every 25 hours of operation. Refer to the engine manual.

CLEANING ENGINE AND BLADE HOUSING

Any fuel or oil spilled on the machine should be wiped off promptly. Grass, leaves, and other dirt must not be left to accumulate around the cooling fins of the engine or on any part of the machine.

Clean the underside of the blade housing after each mowing.

CUTTING BLADES

A. Removal for Sharpening or Replacement



WARNING: Be sure to disconnect and ground the spark plug wire and remove ignition key before working on the cutting blade to prevent accidental engine starting. Protect hands by using heavy gloves or a rag to grasp the cutting blades.

1. Remove the large bolt and lock washer which holds the blade and adapter to the blade spindle.
2. Remove the blade and adapter from the spindle.
3. If the blade or blade adapter needs replacing, remove the two small bolts, lock washers and nuts which hold the blade to the adapter.

B. Sharpening

Remove the cutting blades by following the directions of the preceding section.

When sharpening the blades, follow the original angle of grind as a guide. It is **extremely important** that each cutting edge receives an equal amount of grinding to prevent an unbalanced blade. An unbalanced blade will cause excessive vibration when rotating at high speeds, may cause damage to the mower and could break, causing personal injury.

The blade can be tested for balance by balancing it on a round shaft screwdriver. Remove metal from the heavy side until it balances evenly.

NOTE: *It is recommended that the blade always be removed from the adapter for the best test of balance.*

C. Reassembly

Before reassembling the blade and the blade adapter to the unit, lubricate the spindle and the inner surface of the blade adapter with light oil. Lubricating the bolt holes, bolts and inner surface of the nuts with light oil is also recommended. A 4 oz. plastic bottle of light oil lubricant is available. Order part number 737-0170. Engine oil may also be used.

When replacing blades, be sure to install the blade with the side of the blade marked "Bottom" (or with part number) facing the ground when the mower is in the operating position.

Blade Mounting Torque

3/8" Dia. Bolt 375 in. lb. min., 450 in. lb. max.

5/16" Dia. Bolt 150 in. lb. min., 250 in. lb. max.

To insure safe operation of your unit, ALL nuts and bolts must be checked periodically for correct tightness.

ENGINE

Refer to separate engine manual for all engine maintenance procedures.

FUEL FILTER

Your unit is equipped with a replaceable in-line fuel filter. Replace filter whenever contamination or discoloration is noticed. Order replacement filter through your engine authorized service dealer.

BELT REMOVAL AND REPLACEMENT



WARNING: Disconnect the spark plug wire and ground it against the engine. Block the wheels of the unit.

NOTE: *Figures 23 through 25 are shown with the unit tipped up for clarity. It is not necessary to tip the unit to remove the belts.*

However, if tipping the unit is desired, remove the battery from the unit. To prevent gasoline leakage, drain the gasoline, or remove the fuel tank cap, place a thin piece of plastic over the neck of the fuel tank and screw on the cap. Be certain to remove the plastic when finished changing the belts. Block unit securely.

REAR DRIVE BELT

1. Unscrew the parking brake knob. Remove the two truss head screws which secure the transmission cover. Remove transmission cover.
2. Disconnect the speed selector rod from the variable speed pulley by removing the cotter pin and flat washer and lifting rod off the 3/8" pin. Refer to figure 16.

3. Push the idler pulley toward the right side of the unit. Lift the belt over the idler pulley.
4. Remove the belt from the variable speed pulley and transmission pulley.
5. Replace belt, and reassemble in reverse order.

FRONT DRIVE BELT

1. To remove the front drive belt, first remove the rear drive belt from the idler pulley and variable speed pulley.
2. Place the lift lever in the disengaged position.
3. Remove the hex bolts (belt keepers) from the engine pulley belt guard. See figure 23.

NOTE: When reassembling, make certain hex bolts are assembled in the same locations from which they were removed. See figure 23.

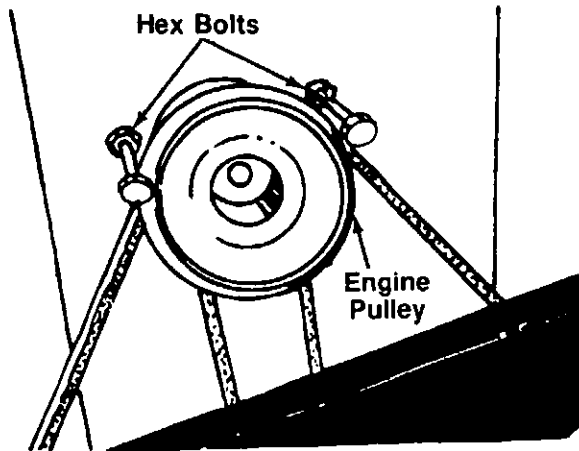

FIGURE 23.

4. Unhook the deck belt from the engine pulley.
5. Remove the two bolts, lock washers and nuts on each side of the frame which hold the engine pulley belt guard to the frame. See figure 24.

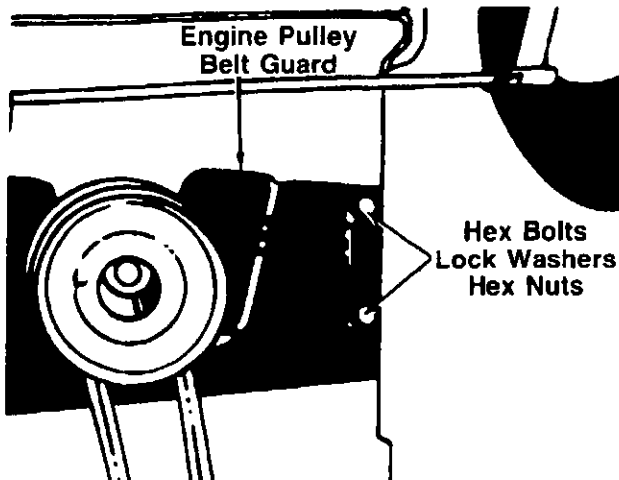

FIGURE 24.

6. Remove the engine pulley belt guard by slipping it back and to the right.
7. Place the clutch-brake pedal in park position.
8. Push forward on the variable speed pulley, and lift the belt off the engine and remove the belt from the engine pulley.
9. Release the clutch-brake pedal. Using the pedal to move the variable speed pulley as necessary, lift the belt up and off the variable speed pulley.

NOTE: When reassembling, make certain belt is inside the pins. See figure 25.

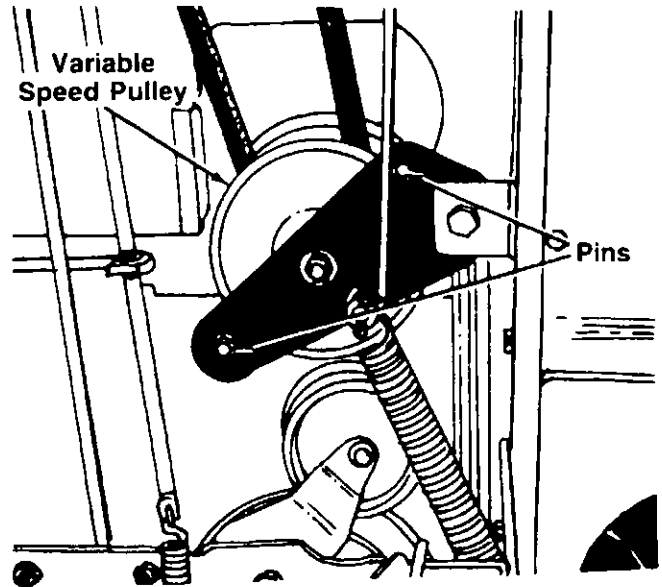

FIGURE 25.

10. Reassemble with a new belt, following instructions in reverse order.
11. Check the adjustment of the speed control as instructed in the Adjustment section of this manual.

BATTERY REMOVAL OR INSTALLATION



WARNING: When removing the battery, follow this order of disassembly to prevent the screwdriver from shorting against the frame.

1. Remove the Negative cable.
2. Remove the Positive cable.

To install a battery:

1. Attach the Positive cable.
2. Attach the Negative cable.

JUMP STARTING

1. Attach the first jumper cable from the Positive terminal of the good battery to the Positive terminal of the dead battery.

2. Attach the second jumper cable from the Negative terminal of the good battery to the FRAME OF THE UNIT WITH THE DEAD BATTERY.



WARNING: Failure to use this starting procedure could cause sparking, and the gas in either battery could explode.

BATTERY MAINTENANCE

1. Check periodically (every two weeks or before and after charging) to be sure electrolyte level is above the lowest line on battery. Add only distilled water or a good quality drinking water. NEVER add additional acid or other chemicals to battery after initial activation.
2. The battery should be checked with a hydrometer after every 25 hours of operation. If the specific gravity is less than 1.225, remove battery and recharge.
3. Coat the terminals and exposed wiring with a thin coat of grease or petroleum jelly for longer service and protection against electrolyte corrosion.
4. The battery should be kept clean. Any deposits of acid should be neutralized with soda and water. Be careful not to get this solution in the cells.

BATTERY STORAGE

1. Charge battery using normal methods. NEVER store discharged battery as it will not recover.
2. When storing battery for extended periods, disconnect battery cables. Removing battery from unit is recommended.
3. Store in cold, dry place.
4. Recharge battery whenever the specific gravity is less than 1.225, before returning to service, or every two months, whichever occurs first.

COMMON CAUSES FOR BATTERY FAILURE ARE:

1. Overcharging
2. Undercharging
3. Lack of water
4. Loose holds downs and/or corroded connections
5. Excessive loads
6. Battery electrolyte substitutes
7. Freezing of electrolyte

NOTE: THESE FAILURES DO NOT CONSTITUTE WARRANTY.

TIRES

Recommended operating tire pressure is approximately 12 p.s.i. (check sidewall of tire for tire manufacturer's recommended pressure). Maximum tire pressure under any circumstances is 30 p.s.i. Equal tire pressure should be maintained on all tires.

When installing a tire to the rim, be certain rim is clean and free of rust. Lubricate both the tire and rim generously. Never inflate to over 30 p.s.i. to seat beads.



WARNING: Excessive pressure (over 30 p.s.i.) when seating beads may cause tire/rim assembly to burst with force sufficient to cause serious injury.

OFF-SEASON STORAGE

If the machine is to be inoperative for a period longer than 30 days, prepare for storage as follows.

1. Clean the engine and the entire unit thoroughly.
2. Lubricate all lubrication points. Wipe the entire machine with an oiled rag to protect the surfaces.
3. Refer to the engine section of this manual for correct engine storage instructions.
4. Refer to battery storage instructions in previous column.
5. Store unit in a clean, dry area.

NOTE: When storing any type of power equipment in an unventilated or metal storage shed, care should be taken to rustproof the equipment. Using a light oil or silicone, coat the equipment, especially any chains, springs, bearings and cables.

TROUBLE SHOOTING CHART FOR ELECTRIC START MODELS

TROUBLE	LOOK FOR	REMEDY
Engine will not crank	Battery installed incorrectly	The battery must be installed with the negative terminal, identified at the terminal post by (Neg. N or -), grounded. The positive terminal (Pos. P or +) attaches to the large cable from the solenoid. The small red wire from the fuse holder or circuit breaker is also attached to the positive terminal.
	Blown fuse or circuit breaker	Replace fuse with 7½ amp. fuse ¼ x 1¼" lg. Circuit breaker will reset itself when it cools off. Fuses or circuit breakers seldom open or fail without a reason. The problem must be corrected. Check for loose connections in the fuse holder. Replace fuse holder if necessary. A dead short may be in the cranking or charging circuit where the insulation may have rubbed through and exposed the bare wire. Replace the wire or repair with electrician's tape if the wire strands have not been damaged. Note: Look for a wire pinched between body panels, burned by the exhaust pipe or muffler or rubbed against a moving part.
	Battery is dead or weak	<p>Use a hydrometer to check the condition of the battery. The Specific Gravity (s.g.) should be 1.265 at 80°F. (1.215 s.g. minimum needed for cranking engine). The reason for the battery failing must be determined. (1) Defective battery. Battery will not accept or hold a full charge. (2) Short circuit. Check for grounded wire. (3) Charging system not working.</p> <p>The charging system is an alternator located under the flywheel. It is unregulated and rated 3 amp. at 3600 r.p.m. A diode (rectifier) is located in the output lead just before the wire harness plug on the engine side.</p> <div style="text-align: center;"> </div> <p>The diode changes A.C. to D.C. to charge the battery. A bad diode can either fail to charge the battery or discharge the battery if the alternator is shorted as well as the diode. To test: (1) Disconnect charger lead from the battery (small red wire). (2) Connect 12 V small test lamp between the 3 amp. D.C. charge lead and the positive terminal of the battery. (3) With the engine off, the lamp should not light. If it does, the diode and possibly the alternator should be replaced. (4) Start the engine. The lamp should light. If it does not, the alternator (stator) or lead wire is bad and should be replaced.</p>
Mechanical failure (Wires and switches)	The interlock system includes two mechanical activated switches which are wired in series in the circuit used to energize the starter solenoid. While testing the interlock system, you will make the mower temporarily unsafe by permitting the engine to be started with the blade and clutch engaged. WARNING: While testing, disengage the clutch, shut off the blade control, set the parking brake and place the gear shift lever in neutral. Attach a wire (minimum 18 gauge) to the positive terminal of the battery and touch the other end to the small terminal on the solenoid. If the engine does not crank: (1) There is a loose connection or poor ground. (2) The solenoid may be bad. The solenoid can be checked by using a heavy wire (#8 gauge minimum) and jumping between the two large terminals. If the engine cranks, the solenoid is bad. (3) If the engine does not crank when you jump the solenoid, have the starter motor tested by an authorized engine dealer. If the engine does crank, the problem is with one of the safety switches, ignition switch or the wire between the fuse holder (or circuit breaker) and the small terminal on the solenoid. Note: Look for a poor connection at the switches or a defective switch. Replace if necessary.	
Engine cranks but will not start	Throttle or choke not in starting position	Check owner's guide for correct position for throttle control and choke for starting.
	No spark to spark plug	<p>Spark plug lead disconnected. Connect lead. Hold spark plug lead away from engine block about 1/8". Crank engine. There should be a spark. If not, have engine repaired at authorized engine service dealer.</p> <p>Faulty spark plug. To test, remove spark plug. Attach spark plug lead to spark plug. Ground the spark plug body against the engine block. Crank the engine. The spark plug should fire at the electrode. Replace if it does not.</p>

TROUBLE SHOOTING CHART FOR ELECTRIC START MODELS

TROUBLE	LOOK FOR	REMEDY
	No fuel to the carburetor	Gasoline tank empty. Fill. Fuel line or in-line fuel filter plugged. Remove and clean fuel line. Replace filter if necessary.
	Air filter dirty	If the air cleaner is dirty, the engine may not start. Clean or replace as recommended by the engine manufacturer.
Engine smokes	Engine loses crankcase vacuum	Dipstick not seated or broken. Replace defective part. Engine breather defective. Replace.
Excessive vibration	Bent or damaged blade spindle	Stop engine immediately. Check all pulleys, blade adapters, keys and bolts for tightness and damage. Tighten or replace any damaged parts.
	Bent blade	Stop engine immediately. Replace damaged blade. Only use original equipment blades.
Mower will not discharge grass or leaves uncut strips	Engine speed low Transmission selection Blades short or dull	Throttle must be set between 3/4 and full throttle. Use lower transmission speed. The slower your ground speed, the better the quality of cut. Sharpen or replace blades (uncut strip problem only).

130754F

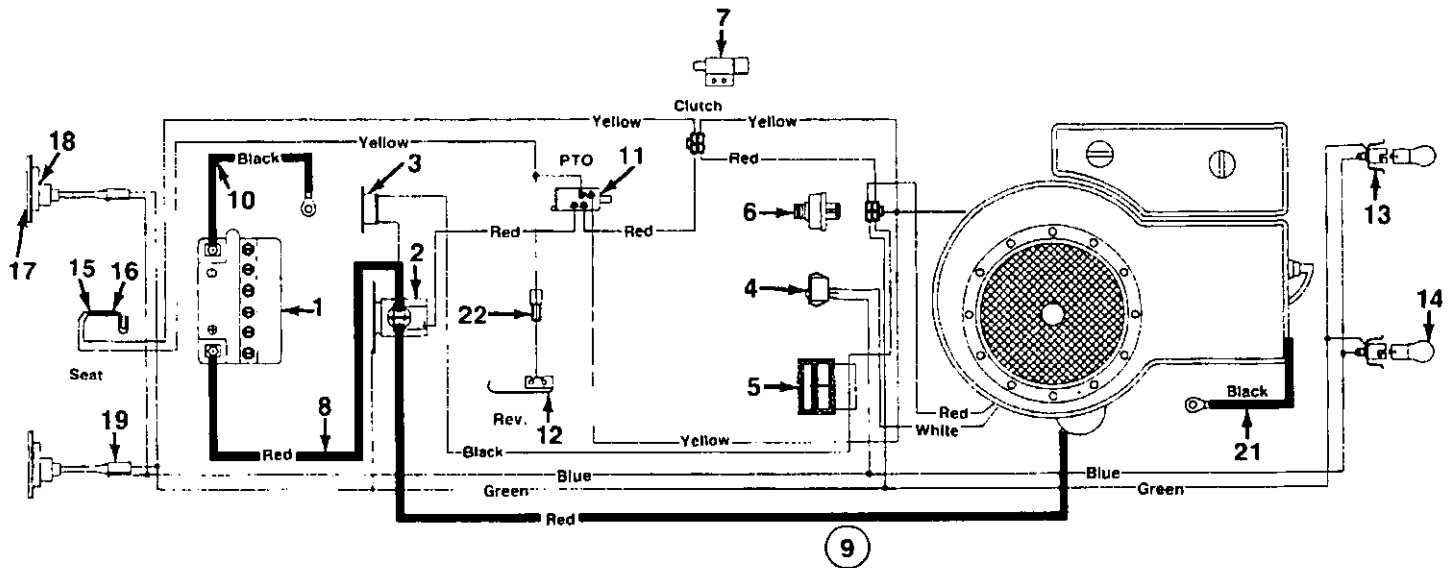

PARTS LIST FOR ELECTRICAL DIAGRAM

REF. NO.	PART NO.	CODE	DESCRIPTION	REF. NO.	PART NO.	CODE	DESCRIPTION
1	725-0514A		Battery	12	725-0759		Safety Switch (Reverse)
2	725-1426	N	Solenoid	13	725-1058A		Twist Lock—Bulb Socket
3	725-0459		Circuit Breaker	14	725-0963		Bulb
4	725-0634		Light Switch	15	725-1303		Safety Switch (Seat)
5	725-0925		Ammeter	16	725-1439		Safety Switch (Seat)
6	725-0267		Ignition Switch	17	725-3020		Taillight Bulb
7	725-3169	N	Safety Switch (Clutch)	18	725-3018		Taillight
8	725-1351		Electric Wire 8" Lg.	19	725-1380		Taillight Harness
9	725-1495	N	Wire Harness	20	726-0152		Mounting Clamp (Not Shown)
10	725-0977		Ground Wire 11.5" Lg.	21	725-0980		Ground Wire—7.5" Lg.
11	725-0803B		Safety Switch (Deck)	22	725-1399		Extension Wire

130754F

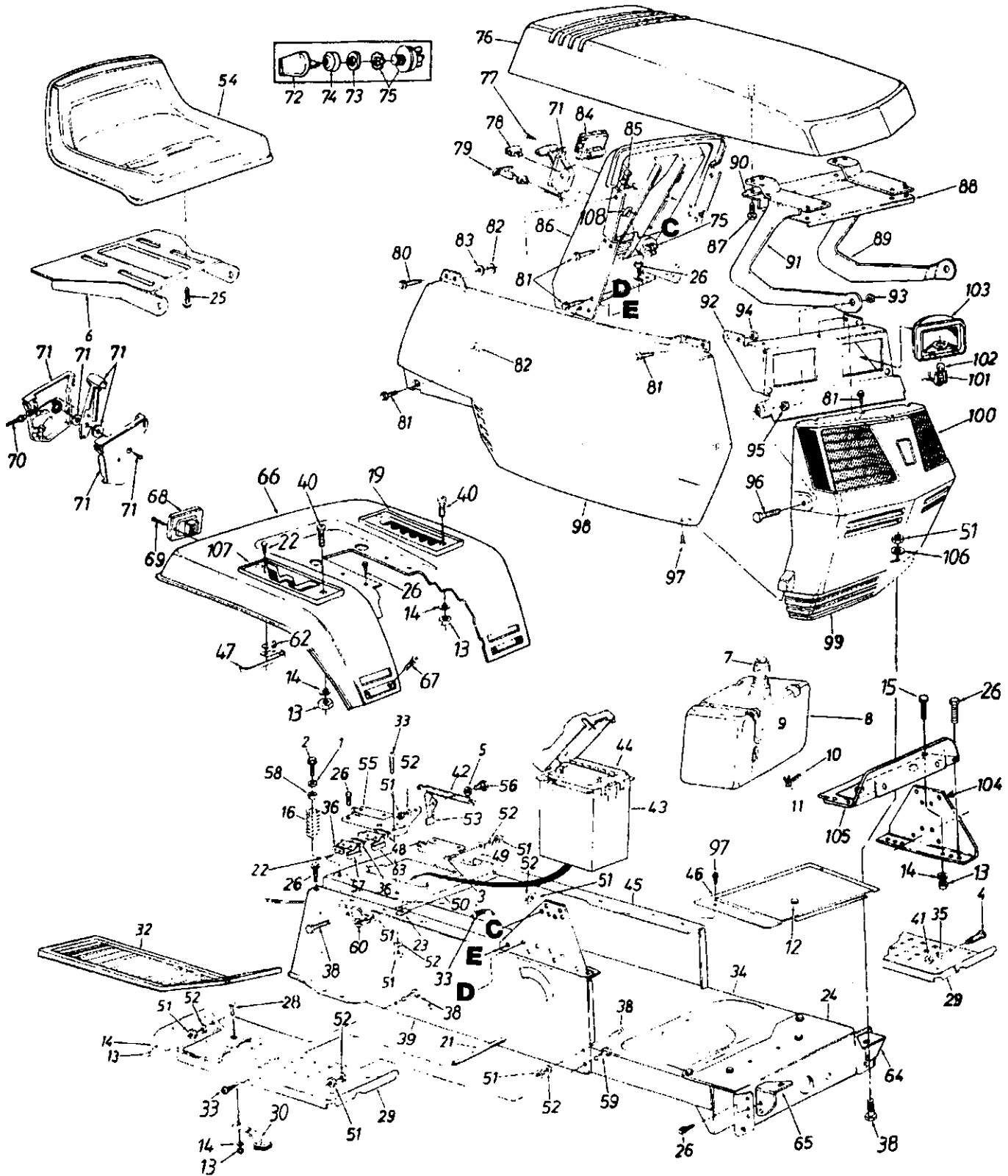

130754F

PARTS LIST FOR MODEL 130754F LAWN TRACTOR

REF. NO.	PART NO.	CODE	DESCRIPTION	REF. NO.	PART NO.	CODE	DESCRIPTION
1	736-0159		Fl-Wash. .344" I.D. x .875"	58	722-0160		Bushing
2	710-0817		Hex Wash. Hd. Tap Scr. 5/16-18 x 1.25" Lg.	59	710-0971		Truss Hd. Scr. 5/16-18 x 1.0" Lg.
3	738-0155		Shld. Bolt .437" Dia. x .162"	60	736-0607		External L-Wash. 5/16" I.D.
4	738-0145		Shld. Bolt .50" Dia. x .84"	62	726-0222		Insulator Nut Plate
5	736-0141		Spr-Wash. .445" I.D. x .75"	63	725-1439	N	Safety Switch (Seat)
6	15607D		Seat Pivot Bracket	64	705-0167	N	Grille Mount Brkt.—L.H.
7	751-3071		Fuel Cap w/o Gasket	65	705-0166	N	Grille Mount Brkt.—R.H.
8	751-0553	N	Fuel Tank	66	17326	499/N	Fender
9	726-0209		Tie Strap	67	710-0167		Carriage Bolt 1/4-20 x .62" Lg.
10	751-0535-15		Fuel Line	68	725-3018		Taillight
11	726-0205		Hose Clamp	69	710-0936		Truss Hd. AB-Tap Scr. #6 x .62" Lg.
12	731-0405		Snap Bushing	70	746-0500		Throttle Wire 26" Lg.
13	712-0287		Hex Nut 1/4-20 Thd.*	71	831-0823A		Throttle Control Box Ass'y.
14	736-0329		L-Wash. 1/4" I.D.	72	725-1341B		Ignition Key
15	710-0258		Hex Bolt 1/4-20 x .62" Lg.*	73	725-1346		Ignition Switch Nut
16	732-0588		Compression Spring	74	725-1347		Ignition Switch Cap
19	731-1069		7-Speed Index Brkt.	75	725-0267		Ignition Switch
21	738-0526		Running Board Rod	76	731-0932B	499	Hood
22	710-0227		Hex Wash. Hd. AB-Tap Scr. #8 x .50" Lg.	77	710-0779A		Truss Mach. AB-Tap Scr. #10 x .5" Lg.
23	726-0139		Speed Nut #10Z	78	725-0634		Light Switch
24	17621	N	Front Pivot Brkt.	79	746-0614A		Choke Control 38" Lg.
25	710-0623		Hex Tap Scr. 3/8-16 x .75"	80	710-0642		Hex Wash. Hd. Tap Scr. 1/4 x .75" Lg.
26	710-0726		Hex Wash. Hd. AB-Tap Scr. 5/16 x .75" Lg.	81	710-0599		Hex Tap Scr. 1/4-20 x .5" Lg.
28	710-0134		Carriage Bolt 1/4-20 x .62" *	82	726-0233		Push Nut Fastener
29	17770	N	Running Board (R.H. & L.H.)	83	736-0176		Fl-Wash. .27" I.D. x .948"
30	761-0168A	N	Blade Brake Ass'y.	84	725-0925		Ammeter
32	731-0911		Rubber Foot Pad—L.H.	85	712-0185		Speed Nut 1/4-20 Thd.
	731-0912		Rubber Foot Pad—R.H.	86	731-0956		Dash Panel
33	710-0323		Truss Mach. Scr. 5/16-18 x .75" Lg.*	87	710-0896		Hex Wash. Hd. B-Tap Scr. 1/4 x .62" Lg.
34	17620A	N	Lower Frame	88	16808		Hood Reinforcement
35	736-0169		L-Wash. 3/8" I.D.*	89	17761	N	Hood Hinge—L.H.
36	726-0279	N	Insulator Plate	90	17762	N	Hood Reinforcement Spacer
38	710-0118		Hex Bolt 5/16-18 x .75" Lg.*	91	17760	N	Hood Hinge—R.H.
39	17830	638/N	Upper Frame—R.H.	92	17223		Light Bracket
40	710-0924		Truss Mach. Scr. 1/4-20 x .75" Lg.	93	712-0158		Hex L-Nut 5/16-18 Thd.
41	712-0798		Hex Nut 3/8-16 Thd.*	94	712-0107		Hex L-Nut 1/4-20 Thd.
42	732-0581		Extension Spring 5.31" Lg.	95	712-3007		Hex Jam Nut 5/16-18 Thd.
43	731-0871A		Battery Box w/Cover	96	710-3038	N	Hex Bolt 5/16-18 x 7/8" Lg.
44	725-0514A		12-V Battery	97	710-0351		Truss Mach. B-Tap Scr. #10 x .5" Lg.
45	17831	638/N	Upper Frame—L.H.	98	731-0938	499	Side Cover—R.H.
46	17835	N	Shift Cover		731-0943	499	Side Cover—L.H. (Not Shown)
47	725-0759		Reverse Safety Switch	99	731-0935	499	Grille
48	726-0278	N	Insulator Boss Plate	100	731-0949		Lens—L.H.
49	17701	N	Seat Pivot Brkt. Support—L.H.		731-0948		Lens—R.H.
50	17225A	N	Hitch Plate	101	725-1058A		Twist Lock—Lamp Socket
51	712-0267		Hex Nut 5/16-18 Thd.*	102	725-0963		Lamp
52	736-0119		L-Wash. 5/16" I.D.*	103	731-0705		Headlight Housing
53	17239A	N	Seat Lift Brkt.	104	17300C	N	Dash Support Brkt.
54	757-0338		Seat	105	17633	N	Gas Tank Support Brkt.
55	17702	N	Seat Pivot Brkt. Support—R.H.	106	736-0275		Fl-Wash. .34" I.D. x .68"
56	738-0296		Shld. Bolt .437" Dia. x .268"	107	731-1147	N	Forward/Reverse Index Brkt.
57	725-1303		Spring Switch	108	17782	N	Choke Retainer

130754F

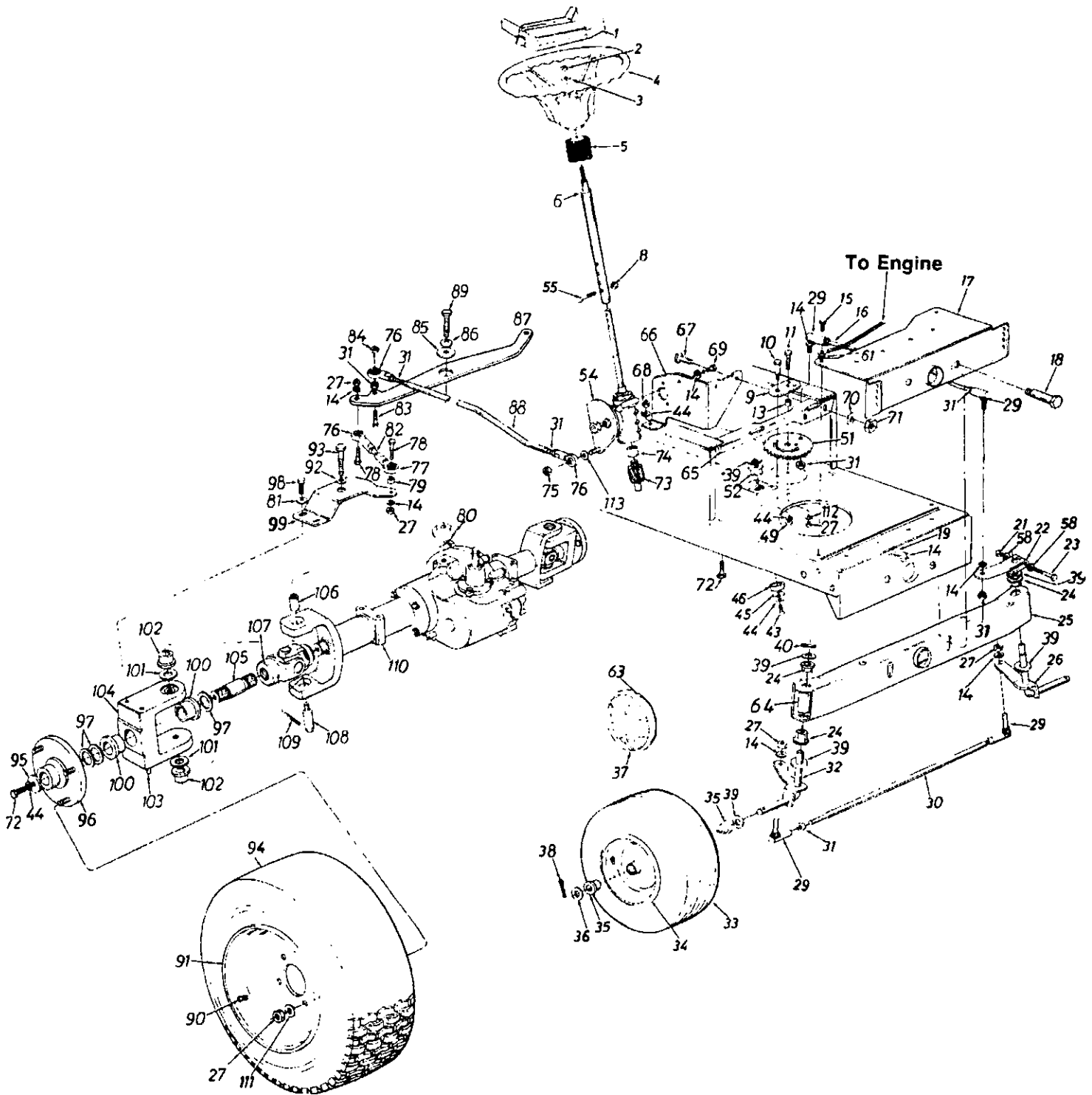

130754F

PARTS LIST FOR MODEL 130754F LAWN TRACTOR

REF. NO.	PART NO.	CODE	DESCRIPTION	REF. NO.	PART NO.	CODE	DESCRIPTION
1	731-0955		Steering Wheel Insert	61	736-0607		Ext. L-Wash. 5/16" I.D.
2	712-0237		Hex L-Nut 5/16-24 Thd.	63	727-0425		Spring Clip (Used w/Ref. 37)
3	736-0242		Belleville Wash. .345" I.D.	64	731-1134		Plastic Tube
4	731-0806A		Steering Wheel	65	17778	N	Horizontal Cross Bracket
5	731-0954		Steering Bellow	66	17777	N	Vertical Mounting Bracket
6	16512		Steering Column Ass'y.	67	710-0412		Hex Bolt 1/4-28 x .75" Lg.
8	712-0324		Hex L-Nut 1/4-20 Thd.	68	712-0123		Hex Nut 5/16-24 Thd.
9	17198		Retainer Plate	69	710-0253		Hex Bolt 3/8-16 x 1.0" Lg.*
10	738-0141		Shoulder Bolt .437" Dia. x .35" Lg. 5/16-18 Thd.	70	736-0270		Bell-Wash. .265" I.D. x .75"
11	710-0152		Hex Bolt 3/8-24 x 1.0" Lg. (Grade 5)	71	712-0138		Hex Nut 1/4-28 Thd.*
13	750-0535		Spacer .380" I.D. x .625" O.D. x .227"	72	710-0157		Hex Bolt 5/16-24 x .75" Lg.
14	736-0169		L-Wash. 3/8" I.D.*	73	717-1700	N	Pinion Shaft
15	710-0726		Hex Wash. Hd. Self-Tap Scr.	74	717-1705	N	Steering Shaft Splined Coupler
16	711-0788		Steering Drag Link	75	712-0262		Hex L-Nut 3/8-24 Thd.
17	17621	N	Front Pivot Brkt.	76	723-0420	N	Rod End 3/8-24 Thd.—R.H.
18	738-0527		Shoulder Bolt .498" Dia. x 2.04" Lg. 3/8-16 Thd.	77	723-0421		Rod End 3/8-24 Thd.—L.H.
19	712-0798		Hex Nut 3/8-16 Thd.*	78	710-0459		Hex Bolt 3/8-24 x 1.5" Lg. (Gr. 5)
21	712-0237		Hex Cent. L-Nut 5/16-24 Thd.	79	750-0535		Spacer .38" I.D. x .625"
22	16481		Steering Arm Front Axle	80	750-0809		Shld. Spacer .51" I.D.
23	710-0772		Hex Bolt 5/16-24 x 2.00" Lg. (Grade 5)	81	736-0105		Bell-Wash. .38" I.D. x .88"
24	741-0225		Hex Flg. Brg. .634" I.D.	82	747-0761		Tie Rod
25	14608		Pivot Bar Ass'y.	83	710-0191		Hex Bolt 3/8-24 x 1.25" Lg.*
26	17753	N	Front Axle Ass'y.—L.H.	84	712-0296		Hex Patch L-Nut 3/8-24 Thd.
27	712-0241		Hex Nut 3/8-24 Thd.*	85	736-3027	N	Fl-Wash. .531" I.D. x 1.75"
29	723-3018		Ball Joint 3/8-24 Thd.	86	736-0253		Bell-Wash. .505" I.D. x 1.0"
30	747-0753	N	Tie Rod	87	17764	N	Steering Boom
31	712-0711		Hex Jam Nut 3/8-24 Thd.*	88	738-0838	N	Steering Link
32	17754	N	Front Axle Ass'y.—R.H.	89	710-3181		Hex Bolt 1/2-13 x 1.5" Lg. (Gr. 5)
33	734-1619		Wheel Ass'y. Comp.**	90	734-0255		Air Valve
	734-0864		Tire Only**	91	734-1607		Rim Only
34	734-0997A		Front Wheel Rim Only	92	736-0921	N	L-Wash. 1/2" I.D.
	734-0255		Air Valve	93	710-1134	N	Hex Bolt 1/2-20 x 2" Lg.
	737-0146		Grease Fitting	94	734-1668	N	Rear Wheel Ass'y. Comp.
35	741-0353		Flange Bearing		734-1596	N	Tire Only
36	736-0285		Fl-Wash. .635" I.D. x 1.59" O.D.	95	736-0343		Fl-Wash. .33" I.D. x 1.25"
37	734-1612	N	Front Hub Cap	96	717-1298	N	Wheel Flange Ass'y.
	734-1614	N	Rear Hub Cap	97	736-0420		Fl-Wash. 1.0" x 1.56"
38	714-0470		Cotter Pin 1/8" Dia. x 1.25" Lg.*	98	710-0180		Hex Bolt 3/8-24 x .75" Lg.
39	736-0187		Fl-Wash. .640" I.D. x .24" O.D.	99	17646	N	Steering Brkt.—R.H.
40	715-0150		Spring Roll Pin		17647	N	Steering Brkt.—L.H. (Not Shown)
43	710-0538		Hex L-Bolt 5/16-18 x .62"*	100	741-0558	N	Flange Brg. 1.0" I.D.
44	736-0119		L-Wash. 5/16" I.D.*	101	736-0445		Fl-Wash. .76" I.D. x 1.5"
45	736-0343		Fl-Wash. .33" I.D. x 1.25" O.D.	102	741-0547	N	Flange Brg. 3/4" I.D.
46	750-0532		Spacer (Plastic)	103	737-0146		Grease Fitting
49	712-0267		Hex Nut 5/16-18 Thd.*	104	717-1291	N	Wheel Brg. Housing
51	717-1701	N	Steering Gear Segment	105	738-0829	N	Outer Axle
52	741-0225		Hex Flg. Brg. .634 I.D.	106	717-1271	N	Pivot Sleeve
54	717-1049	N	Steering Ass'y.	107	717-1270	N	U-Joint
55	710-0958		Hex Bolt 1/4-20 x 1.31" Lg.	108	717-1266	N	Pivot Pin
58	736-0271		Wave Wash. .32" I.D. x .62"	109	715-0208	N	Grooved Roll Pin 1.0" Lg.
				110	717-1285	N	Axle Horn Ass'y.
				111	736-0105		Bell-Wash. .38" I.D. x .88"
				112	736-0356		Bell-Wash. .39" I.D. x 1.38"
				113	736-0140		Fl-Wash. .385" I.D. x .62"

* For faster service obtain standard nuts, bolts and washers locally. If these items cannot be obtained locally, order by part number and size as shown on parts list.

CODE: N notates a new part (not previously existing). A three digit number is the color code. Specify color code as shown below if color or finish is important when ordering parts. [i.e., 638 for Red Finish].

130754F

IMPORTANT: Use only Original Equipment Manufacturer (O.E.M.) V-belts when replacing belts. They are of special construction (type of cord, cord location, length, etc.). Use of V-belts other than O.E.M. belts generally will provide only temporary service. For best results, use only factory approved parts.

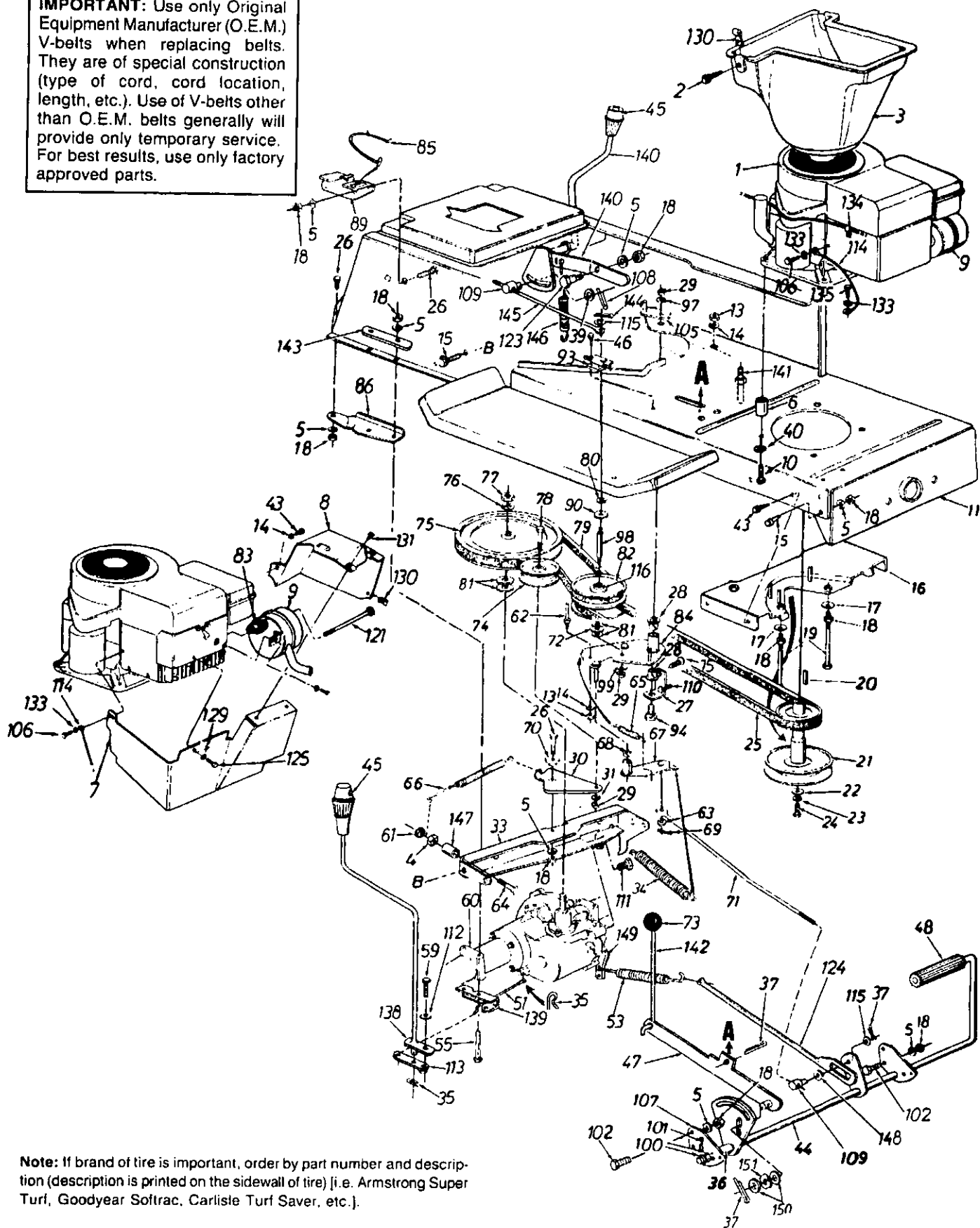

Note: If brand of tire is important, order by part number and description (description is printed on the sidewall of tire) [i.e. Armstrong Super Turf, Goodyear Softrac, Carlisle Turf Saver, etc.].

130754F

PARTS LIST FOR MODEL 130754F LAWN TRACTOR

REF. NO.	PART NO.	CODE	DESCRIPTION	REF. NO.	PART NO.	CODE	DESCRIPTION
1	—		Engine	64	710-1026		Hex Wash. TT-Tap Scr. 1/4-20 x 1.75"
2	710-0473		Truss Mach.Scr. #10-24 x .5" Lg.				Ext. Spring 2.59" Lg.
3	731-1072	N	Air Duct	65	732-0568		Ext. Spring .5" O.D. x 4.35"
4	712-0298		Hex Nut 5/16-24 Thd.*	66	732-0428A		Variable Speed Torque
5	736-0119		L-Wash. 5/16" I.D.*	67	16554A		Brkt. Ass'y.
6	750-0777		Spacer				Flanged Bearing
7	16936		Muffler Heat Shield—Front	68	741-0419		Cotter Pin 3/32" Dia.*
8	16935		Muffler Heat Shield—L.H.	69	714-0507		Shoulder Spacer .27" Lg.
9	751-0465		Muffler	70	748-0234		Speed Control Link
10	710-1007	N	Hex L-Wash. Tap Scr. 3/8-16 Thd.	71	747-0530		Truss Bearing .56 Dia. x 1.25"
11	17620A	N	Lower Frame Ass'y.	72	741-0405		Ball Knob
13	712-0287		Hex Nut 1/4-20 Thd.*	73	720-0166		FI-Idler Pulley 3.25" x .75"
14	736-0329		L-Wash. 1/4" I.D.*	74	756-0437		"V"-Pulley
15	710-0604		Hex Wash. TT-Tap Scr. 5/16-18 x .62" Lg.	75	756-0574	N	L-Wash. 1/2" I.D.*
16	15898		Belt Guard Brkt. Ass'y.	76	736-0921		Hex Jam Nut 1/2-20 Thd.*
17	736-0242		Bell-Wash. .345" I.D. x .88"	77	712-0922		Hex Bolt 3/8-24 x 1.75" Lg.
18	712-0267		Hex Nut 5/16-18 Thd.*	78	710-0539		Variable Speed Belt
19	710-0190		Hex Bolt 5/16-18 x 4.0" *	79	754-0370		Snap Ring .56" Dia.
20	714-0114		Sq. Key 1/4" x 1/4" x 2.00"	80	716-0114		FI-Wash. .56" I.D. x 1.0" O.D.
21	756-0488		Engine Pulley	81	736-0355		Variable Speed Pulley Ass'y. 5" O.D.
22	736-0322		FI-Wash. 7/16" I.D. x 1.25"	82	717-0800		Gasket
23	736-0171		L-Wash. 7/16" I.D.*				Variable Speed Brkt. Ass'y.
24	710-0757		Hex Bolt 7/16-20 x 1.50" Lg.	83	721-0208		Comp. Spring—Clip
25	754-0280		Variable-Speed Belt	84	16354B		Axle Support Brkt.—R.H.
26	710-0118		Hex Bolt 5/16-18 x .75" Lg.	85	732-0525		Axle Support Brkt.—L.H. (Not Shown)
27	16553		Bearing Shaft Bracket Ass'y.	86	17668	N	Speed Cont. Rod Brkt.
28	741-0295		Flanged Nylon Brg. 5/8" I.D. x .88" Lg.		17669	N	Teflon Washer .565" I.D.
29	712-0241		Hex Nut 3/8-24 Thd.*	89	17839	N	Safety Switch (Clutch)
30	17834	N	Idler Bracket	90	736-0414		Shld. Bolt 3/8-24 x 3.12" Lg.
31	736-0169		L-Wash. 3/8" I.D.*	93	725-3169		Bell-Wash. .38" I.D. x .88"
33	17766	N	Transaxle Support Brkt.	94	738-0755		Shaft
34	732-0556		Ext. Spring .94" O.D. x 7.58"	97	736-0105		Bell-Wash. .39" I.D. x 1.12"
35	714-0149B		Inter. Cotter Pin	98	738-0837	N	FI-Wash. .64" I.D. x .94"
36	750-0802		Spacer .63" I.D.	99	736-0331		Cotter Pin 3/32" Dia. x 1.0" *
37	714-0115		Cotter Pin 1/8" Dia. x 1.0" Lg.	100	736-0256		Hex Wash. Hd. S-Tap Scr. 1/4-20 x .50" Lg.
39	736-0108		FL-Wash. .51" I.D. x .75"	101	714-0111		Clutch/Brake Pedal Ass'y.
40	736-0247		FI-Wash. .406" I.D. x 1.25"	102	710-0650		Shift Knob
43	710-0599		Hex Wash. Hd. S-Tap Scr. 1/4-20 x .50" Lg.	105	16067		Hex Wash. Hd. B-Tap Scr. #10 x .5" Lg.
44	17837	N	Clutch/Brake Pedal Ass'y.	106	710-0323		Parking Brake Lockout Brkt. Ass'y.
45	720-0218		Shift Knob				Foot Pad
46	710-1066		Hex Wash. Hd. B-Tap Scr. #10 x .5" Lg.	107	15835A		Shift Lever Rod
47	17837	N	Parking Brake Lockout Brkt. Ass'y.	108	714-0507		Ext. Spring 3.6"
48	735-0196		Foot Pad	109	711-0198		Hex Bolt 5/16-18 x 3.25" *
51	747-0774	N	Shift Lever Rod	110	710-0376		Hex Bolt 1/4-28 x .62" Lg.
53	732-0656		Ext. Spring 3.6"				Transaxle Complete
55	710-3056	N	Hex Bolt 5/16-18 x 3.25" *	111	710-0817		Hex L-Nut 1/4-20 Thd.
59	710-0195		Hex Bolt 1/4-28 x .62" Lg.	112	736-0270		Belt Guard Pin 1/4-20 Thd.
60	717-1287	N	Transaxle Complete	113	17832		FI-Wash. .34" I.D. x .68" O.D.
61	712-0291		Hex L-Nut 1/4-20 Thd.	114	725-0980		Needle Brgs. (2 Req'd.)
62	711-0768		Belt Guard Pin 1/4-20 Thd.	115	736-0140		Shld. Bolt 7/16" Dia. x 3-5/8" Lg.
63	736-0275		FI-Wash. .34" I.D. x .68" O.D.	116	741-0404		
				121	738-0636		

PARTS LIST FOR MODEL 130754F LAWN TRACTOR (CONTINUED)

REF. NO.	PART NO.	CODE	DESCRIPTION	REF. NO.	PART NO.	CODE	DESCRIPTION
123	738-0155		Shld. Bolt .437" Dia. x .162"	140	17768	N	Speed Selector Lever Ass'y.
124	17794	N	Brake Rod Ass'y.	141	711-0747		Belt Guard Pin
125	710-0294		Hex Bolt 1/4-20 x .62" Lg.	142	747-0770	N	Brake Lockout Rod
129	736-0175		Spr. Wash. .265" I.D.	143	17840	N	Transaxle Mtg. Brkt.
130	712-0147		Speed Nut #10-24 Thd.	144	714-0474		Cotter Pin 1/8" x 3/4" Lg.
131	710-0224		Hex AB-Tap Scr. #10 x .5" Lg.	145	747-0771	N	Speed Selector Rod
133	736-0607		External L-Wash. 5/16" I.D.	146	732-0429A		Ext. Spring 3.97" Lg.
134	726-0235		Speed Clip	147	750-0470		Spacer .326" I.D. x .47"
135	710-0726		Hex Wash. AB-Tap Scr. 5/16" x .75" Lg.	148	736-0167		Fl-Wash. 5/8" I.D. x 1.25"
138	747-0768	N	Shift Lever Ass'y.	149	717-0772		Actuating Arm
139	17767	N	Shift Lever Support Brkt.	150	736-0300		Fl-Wash. .385" I.D. x .87" O.D.
				151	736-0413		Wave Wash. .38" I.D. x .75"

CODE: N notates a new part (not previously existing). A three digit number is the color code. Specify color code as shown below if color or finish is important when ordering parts. [i.e., 638 for Red Finish].

*For faster service obtain standard nuts, bolts and washers locally. If these items cannot be obtained locally, order by part number and size as shown on parts list.

499—Beige, 638—Red

Note: If brand of tire is important, order by part number and description (description is printed on the sidewall of tire) [i.e. Armstrong Super Turf, Goodyear Softrac, Carlisle Turf Saver, etc.].

130754F

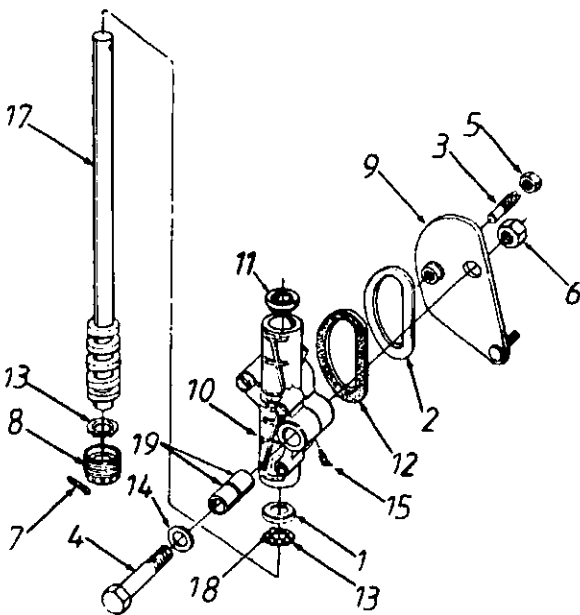

PARTS LIST FOR STEERING ASSEMBLY COMPLETE

REF. NO.	PART NO.	CODE	DESCRIPTION
1	703-1029	N	Bearing Cup
2	703-1031	N	Seal Retainer
3	711-3149	N	Cam Follower
4	711-3208	N	Pivot Shaft
5	712-3062	N	Hex Jam Nut 9/16-18 Thd.
6	712-3063	N	Hex Crown L-Nut 5/8-18 Thd.
7	714-0474		Cotter Pin 1/8" Dia.
8	717-1048	N	Adjustment Plug Ass'y.
9	717-1219	N	Steering Arm Ass'y.
10	719-0285	N	Steering Gear Hsg.
11	721-0260	N	Oil Seal
12	723-3039	N	Seal
13	731-3040	N	Ball Retainer
14	736-3029	N	Fl-Wash. .781" I.D. x 1.25" O.D.
15	737-3001	N	Grease Fitting
17	738-0820	N	Steering Shaft Ass'y.
18	741-3022	N	Ball Bearing
19	748-3008	N	Housing Bushing
—	737-3007	N	Grease #251 E.P. (4 oz. Req'd.)
—	717-1049	N	Steering Ass'y. Comp. (Incl. Ref. Nos. 1 thru 19)

130754F

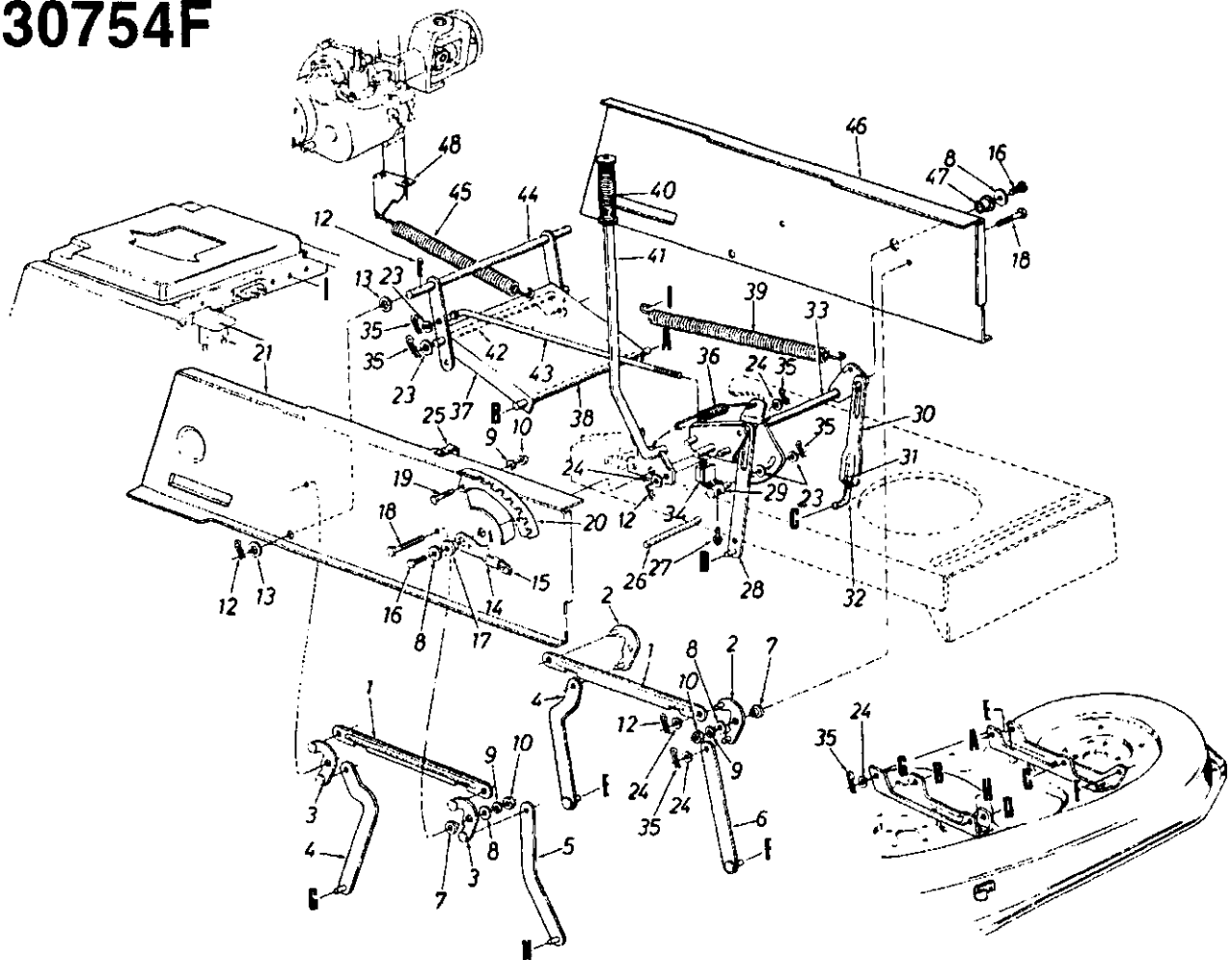

PARTS LIST FOR MODEL 130754F LAWN TRACTOR

REF. NO.	PART NO.	CODE	DESCRIPTION	REF. NO.	PART NO.	CODE	DESCRIPTION
1	09735A		Connecting Rod	25	726-0272		Clamp
2	17640	N	Pivot Link Ass'y.—L.H.	26	738-0526		Running Board Rod
3	17641	N	Pivot Link Ass'y.—R.H.	27	710-0351		Truss Mach. Scr. #10 x .5" Lg.
4	17710	N	Deck Hanger Link Ass'y.	28	14802A		Link Deck Lift Ass'y.
5	14800A	N	Deck Hanger Link Ass'y.	29	711-0723A		Adj. Ferrule 3/8-24 Thd.
6	14804A	N	Deck Hanger Link Ass'y.	30	17712	N	Adj. Deck Lift Link
7	748-0331		Shld. Spacer .318" I.D.	31	712-3066		Hex Nut 1/2-20 Thd. (Gr. 5)
8	736-0231		FI-Wash. .344" I.D. x 1.125"	32	711-0841		Lift Link Adjuster
9	736-0119		L-Wash. 5/16" I.D.*	33	17825	N	Lift Shaft Ass'y.
10	712-0267		Hex Nut 5/16-18 Thd.*	34	725-0803B		Safety Switch (Deck)
12	714-0115		Cotter Pin 1/8" Dia.	35	714-0145		Inter. Cotter Pin 3/8" Dia.
13	736-0256		FI-Wash. .635" I.D. x 1.0" O.D.	36	732-0648	N	Extension Spring
14	732-0412A		Deck Lift—Down Stop (Incl. Ref. 15)	37	17636A	N	Stabilizer Bracket
15	08540		Knob	38	738-0670	N	Shaft 1/2" Dia. x 10.28" Lg.
16	710-0604		Hex Wash. TT-Tap Scr. 5/16-18 x .75" Lg.	39	732-0638	N	Extension Spring
17	748-0176		Flange Brg. .63" I.D.	40	720-0233		Grip (Lift Handle)
18	710-0650		Hex Wash. TT-Tap Scr. 5/16-18 x .875" Lg.	41	17675	N	Deck Lift Handle Ass'y.
19	710-0118		Hex Bolt 5/16-18 x .75" Lg.	42	738-0669	N	Shaft 3/8" Dia. x 9.34" Lg.
20	17730	N	Index Brkt.	43	747-0598	N	Disengagement Rod
21	17830	N	Upper Frame—R.H.	44	17624	N	Stabilizer Shaft Ass'y.
23	736-0267		FI-Wash. .385" I.D. x .87" O.D.	45	732-0556		Extension Spring 7.58" Lg.
24	736-0160		FI-Wash. .531" I.D. x .93" O.D.	46	17831	N	Upper Frame—L.H.
				47	741-0313		Flange Brg. .632" I.D.
				48	17128	N	Spring Retainer Brkt.

130754F

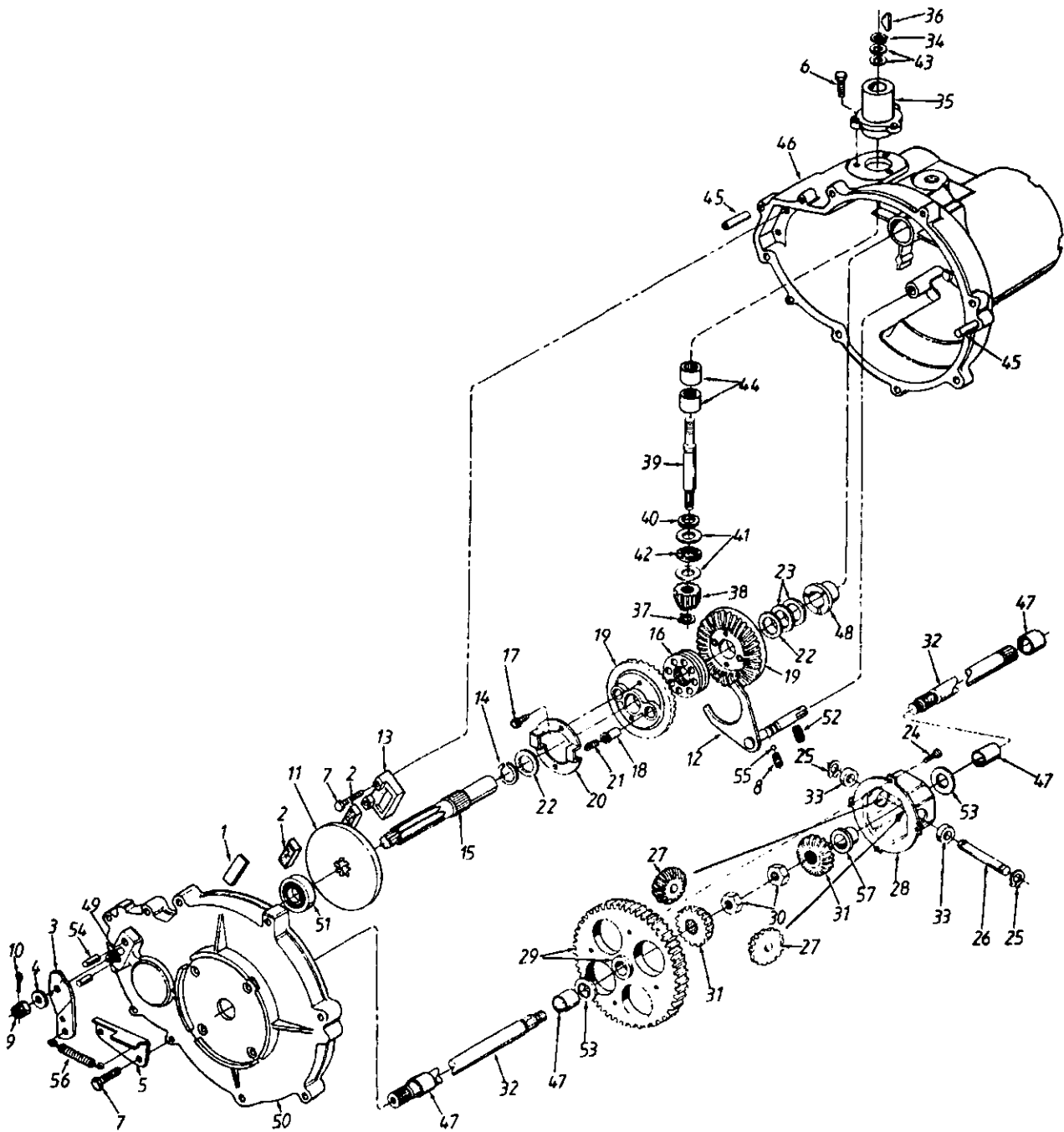

130754F

PARTS LIST FOR MODEL 130754F LAWN TRACTOR

REF. NO.	PART NO.	CODE	DESCRIPTION	REF. NO.	PART NO.	CODE	DESCRIPTION
1	717-0682		Puck Plate	29	717-1254	N	Differential Gear Ass'y.
2	717-0678		Brake Puck				w/Bearing
3	717-0772		Actuating Arm	30	712-0200A		Hex Ins. L-Nut 1/2-20 Thd.
4	736-0371		Fl-Wash. 11/32" I.D. x 7/8" O.D.	31	717-1019		Miter Gear
5	17841	N	Brake Stop Brkt.	32	717-1197	N	Axle
6	710-0433		Hex Bolt 1/4-20 x .62" Lg. (Special)	33	750-0787		Differential Thrust Spacer
7	710-0809		Hex Tap Scr. 1/4-20 x 1.25" Lg.	34	716-0115		Snap Ring
8	732-0863		Spring Detent	35	717-1228	N	Input Bearing Housing
9	712-0335		Castle Nut 5/16-24 Thd.	36	714-0129		#4 Hi-Pro Key 3/32" x 5/8" Dia.
10	714-0111		Cotter Pin 3/32" Dia. x 1" Lg.	37	716-0108		Retaining Ring
11	717-1092	N	Brake Disc	38	717-0633		Pinion Input 14T
12	717-1102	N	Shifter Ass'y.	39	717-0634		Input Shaft
13	717-1217	N	Brake Puck Holder	40	721-0178		Seal 5/8" I.D.
14	716-0175		Retaining Ring	41	736-0419		Thrust Wash. .621" I.D. x 1.12"
15	717-1093	N	Shaft Drive	42	741-0469		Thrust Bearing
16	717-1268	N	Shift Collar	43	736-0349		Fl-Wash. 5/8" I.D. x 1.0" O.D.
17	710-0653		Hex Wash. Hd. Tap Scr. 1/4-20 x .38" Lg.	44	741-0335		Needle Brg. 5/8" x 1/2" Lg.
18	717-1184	N	Drive Pin	45	715-0209		Dowel Pin
19	717-1275	N	Bevel Gear Ass'y. (Incl. Ref. Nos. 17, 18, 20 and 21)	46	717-1235	N	R.H. Housing
20	717-1269	N	Spring Retaining Plate	47	741-0340		Sleeve Bearing 3/4" I.D.
21	732-0590		Drive Spring	48	741-0548	N	Flange Bearing .906" I.D.
22	736-0444		Fl-Wash. .915" I.D. x 1.5" O.D.	49	717-0796		Sq. Head Bolt 5/16-24 Thd.
23	736-0454		Fl-Wash. .915" I.D. x 1.37" O.D.	50	717-1234	N	L.H. Housing
24	710-0862		Pan Hd. Scr. 1/4-20 x .5" Lg.	51	741-0124		Ball Bearing .669" I.D.
25	716-0142		Snap Ring	52	710-3006	N	Set Screw 5/16-18 x 3/8" Lg.
26	717-0673		Cross Shaft	53	736-0445		Fl-Wash. .76" I.D. x 1.5" O.D.
27	717-1020		Miter Gear 15T	54	741-0343		Brake Actuating Pin
28	717-1252	N	Differential Cam Assembly	55	741-0862		Ball Detent
				56	732-0545		Ext. Spring 1.14" Lg.
				57	741-0552	N	Differential Flange Brg.

YARD-MAN PARTS INFORMATION

POWER EQUIPMENT PARTS AND SERVICE

Parts and service for all YARD-MAN manufactured power equipment are available through local Authorized Service Dealers. Check the yellow pages. All orders should specify the model number of your unit, part numbers, description of parts and the quantity of each part required. **DO NOT SEND PARTS ORDERS TO FACTORY.** Service Distributors listed below, identified by state abbreviation, may be contacted for service assistance.

NC ALLISON-ERWIN CO.
SC 2920 N. Tryon Street
P.O. Box 32308
Charlotte, NC 28232
(704) 334-8621

C-CA ALL SEASON EQUIPMENT
169 S. Hewes Street
Orange, CA 92669
(714) 639-7272

S-CA BILLIOUS
75 N "D" Street
Porterville, CA 93257
(209) 784-4102

N-CA BLISS POWER LAWN
NV EQUIPMENT
101 Commerce Circle
Sacramento, CA 95815
(916) 925-6936

ME M. L. COFFIN CO.
NH 725 Broadway
VT Bangor, ME 04401
(207) 942-8289

MS DICKERSON DISTRIBUTORS,
AL INC.
N-GA P.O. Drawer 231
127 N. W. Depot
Durant, MS 39063
(601) 653-3004

S-FL FLORIDA TURF & GARDEN
EQUIPMENT
7275 NW 64th St.
Miami, FL 33166
(305) 592-3846

UP-NY GAMBLE DISTRIBUTING INC.
P.O. Box 389
West End Ave.
Carthage, NY 13619
(315) 493-2270

MI IDEAL MOWER SALES
811 Woodward Heights
Ferndale, MI 48220
(313) 541-4660

C-FL MANLEY TRACTOR SALES
5909 E. Broadway
Tampa, FL 33619
(813) 626-5900

IN McDONOUGH & ASSOCIATES
8535 E. 30th St.
P.O. Box 1915
Indianapolis, IN 46219
(317) 898-4200

WI MERCOR CORP.
4080 N. Pt. Washington Rd.
P.O. Box 12145
Milwaukee, WI 53212
(414) 961-3200

NJ DE NIEMEYER CORP.
NY MD 1135 Phoenixville Pike
PA P.O. Box 1477
WA-DC West Chester, PA 19380
(215) 431-7200

MN NORTHSTAR OUTDOOR
IA EQUIPMENT CORP.
ND Hwy. 25 & 18, P.O. Box 764
SD Brainerd, MN 56401
(218) 829-4271

MO OZARK EQUIPMENT CO.
E-KS Hwy. 63 & Black Street
Rolla, MO 65401
(314) 364-2180

IL PLANTE'S LAWN & GARDEN
4 Grant St.
N. Aurora, IL 60542
(312) 892-2220

BRIGGS & STRATTON, TECUMSEH AND PEERLESS PARTS AND SERVICE

Briggs & Stratton, Tecumseh and Peerless parts and service should be handled by your nearest authorized engine service firm. Check the yellow pages of your telephone directory under the listing **Engine—Gasoline**, Briggs & Stratton or Tecumseh Lauson.

N-FL POWER EQUIP. DIST. INC.
S-GA 565 S. Edgewood Ave.
S-AL Jacksonville, FL 32205
(904) 387-1512

UT MT POWERED PRODUCTS
WY S-ID 1661 N. Beck St.
Salt Lake City, UT 84116
(801) 359-9767

OH RAHRIG SALES INC.
108-110 W. Lima St.
Forest, OH 45843
(419) 273-2556

KY RASCHE CYCLE CO.
TN 713 Kentucky Ave.
Paducah, KY 42001
(502) 443-8142

C-FL SPAULDINGS INC
P.O. Box 10009
1921 5th Ave S.
St. Petersburg, FL 33712
(813) 896-2611

CO SPITZER INDUSTRIAL PRODUCTS
6601 N. Washington Street
Denver, CO 80229
(303) 287-3414

AR TIMBERLAND SAW CO.
LA Hwy. 31 South
OK P.O. Box 1227
TX Marshall, TX 75671
(214) 935-5251

CANADA MTD PRODUCTS CANADA
97 Kent Ave.
Kitchener, Ontario
Canada, N2G 4J1
(519) 579-5500

EXPORT DRAKE AMERICA CORP.
#2 Gannett Drive
White Plains, NY 10604
(914) 697-9800

WARRANTY PARTS AND SERVICE POLICY

(0889)

The purpose of warranty is to protect the customer from defects in workmanship and materials, defects which are NOT detected at the time of manufacture. It does not provide for the unlimited and unrestricted replacement of parts. Use and maintenance are the responsibility of the customer. The manufacturer cannot assume responsibility for conditions over which it has no control. Simply put, if it's the manufacturer's fault, it's the manufacturer's responsibility; if it's the customer's fault, it's the customer's responsibility.

CLAIMS AGAINST THE MANUFACTURER'S WARRANTY INCLUDES:

1. Replacement of Missing Parts on new equipment.
2. Replacement of Defective Parts within the warranty period.
3. Repair of Defects within the warranty period.

All claims MUST be substantiated with the following information:

1. Model Number, Serial Number and/or Date Code of unit involved.
2. Date unit was purchased or first put into service.
3. Date of failure—Date Repaired.
4. Nature of failure—Correction.