

\$1.00

YARD-MAN

OUTDOOR POWER EQUIPMENT
for all seasons



Spring



Summer



Fall



Winter

Owner's Manual

- ASSEMBLY
- OPERATION
- MAINTENANCE
- PARTS LIST

IMPORTANT:

Read Safety Rules and
Instructions Carefully

Thank you for purchasing
an American-built product.

21" 6 SPEED CONVERTIBLE ROTARY MOWERS

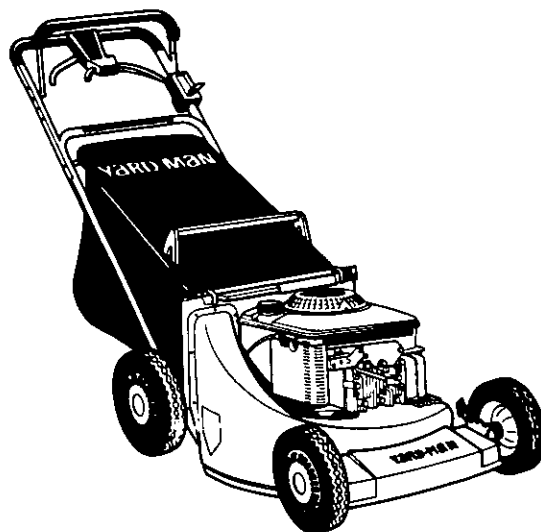

Model Numbers
120897R
120898R
120899R

INDEX

Slope Gauge	3
Contents of Hardware Pack	4
Safe Operation	5
Assembly Instructions	6
Controls	13
Operation	14
Adjustments	15
Lubrication	16
Maintenance	16
Off-Season Storage	18
Trouble Shooting Guide	19
Replacement Parts	20-24
Parts Information	Back Cover

Dear Customer,

So often throughout the year we are all in a rush to meet our daily obligations.

However, we at YARD-MAN COMPANY are taking a quick moment out to say . . .

"Thank you for your business."

Sincerely,
YARD-MAN COMPANY



INSTRUCTIONS GIVEN WITH THIS SYMBOL ARE FOR PERSONAL SAFETY. BE SURE TO FOLLOW THEM.

LIMITED WARRANTY

For two years from the date of original retail purchase, YARD-MAN COMPANY will either repair or replace, at its option, free of charge, F.O.B. factory or authorized service firm, any part or parts found to be defective in material or workmanship. Transportation charges for the movement of any power equipment unit or attachment are the responsibility of the purchaser. Transportation charges for any parts submitted for replacement under this warranty must be paid by the purchaser unless such return is requested by YARD-MAN COMPANY.

This warranty will not apply to any part which has become inoperative due to misuse, excessive use, accident, neglect, improper maintenance, alterations, or if the unit has not been operated and maintained in accordance with the instructions furnished. This warranty does not apply to the engine, Peerless components, motor, battery (except as noted below) or component parts thereof. Please refer to the applicable manufacturer's warranty on these items.

A battery which proves defective within ninety (90) days will be replaced without charge. After 90 days but within one year from the date of purchase, YARD-MAN will replace the defective battery for a charge of 1/12 of the current retail price of the battery for each full 30 day period between the date of purchase and the date of return.

Warranty on units used commercially is limited to sixty (60) days.

Warranty service is available through your local authorized service dealer or distributor. If you do not know the dealer or distributor in your area, please write to the Customer Service Department of YARD-MAN.

The return of a complete unit will not be accepted by the factory unless prior written permission has been extended by YARD-MAN.

This express limited warranty is in lieu of all other warranties, express or implied, including any implied warranty of merchantability. The remedy of replacement is the sole and exclusive remedy for YARD-MAN obligations arising from the sale of its products. In no case will YARD-MAN be liable for incidental or consequential loss or damage.

This warranty gives you specific legal rights. You may also have other rights which vary from state to state.

WARNING: This unit is equipped with an internal combustion engine and should not be used on or near any unimproved forest-covered, brush-covered or grass-covered land unless the engine's exhaust system is equipped with a spark arrester meeting applicable local or state laws (if any). If a spark arrester is used, it should be maintained in effective working order by the operator.

In the State of California the above is required by law (Section 4442 of the California Public Resources Code). Other states may have similar laws. Federal laws apply on federal lands. A spark arrester for the muffler is available through your nearest engine authorized service dealer.

Cut Along This Line

USE THIS SHEET AS A GUIDE TO DETERMINE SLOPES WHERE YOU MAY NOT OPERATE SAFELY.

SLOPE GAUGE

(Keep this sheet in a safe place for future reference.)

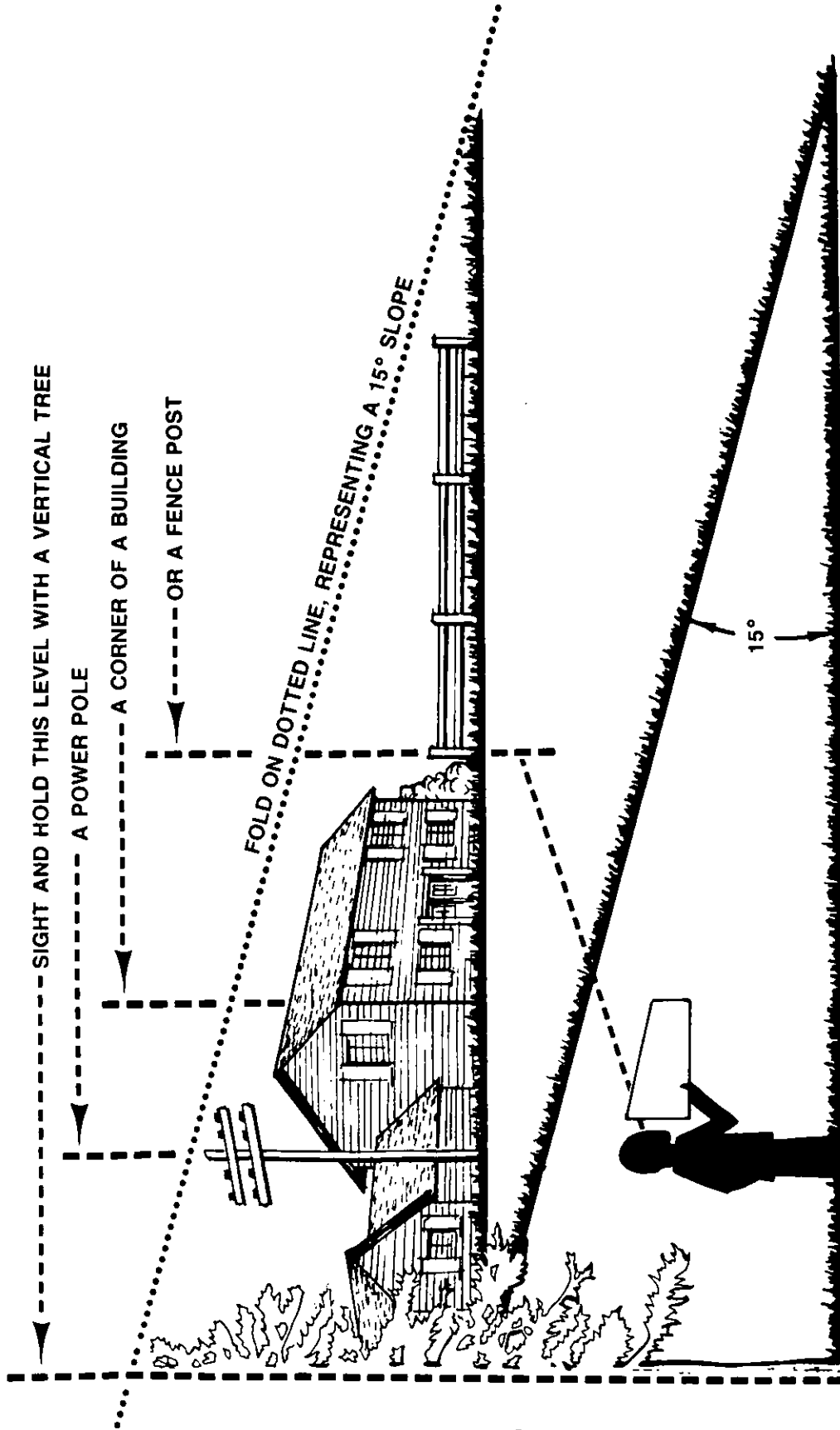

Do not mow on inclines with a slope in excess of 15 degrees (a rise of approximately 2½ feet every 10 feet). A riding mower could overturn and cause serious injury. If operating a walk-behind mower on such a slope, it is extremely difficult to maintain your footing and you could slip, resulting in serious injury.

Operate RIDING mowers up and down slopes, never across the face of slopes.

Operate WALK-BEHIND mowers across the face of slopes, never up and down slopes.

CONTENTS OF HARDWARE PACK

Remove this sheet from your owner's manual and lay the hardware on the illustration for identification purposes. After assembly, keep the Slope Gauge which is on the reverse side of this sheet for future use.

(Hardware pack may contain extra items which are not used on your unit.)

A ATTACHING THE LOWER HANDLE

Truss Machine Screw
5/16-18 x 3/4"
Long

Split Washer
5/16" I.D.

Hex Nut
5/16-18
Thread

E ATTACHING THE DRIVE CLUTCH CONTROL CABLE

Plastic Cap

Phillips Head Screws

B ATTACHING THE UPPER HANDLE

Rope Guide Bolt

Curved Head Bolt

Split Washers
5/16" I.D.

Hex Nuts
5/16-18
Thread

F FINAL ASSEMBLY

Plastic Plug
(If Required)

C GRASS CATCHER ASSEMBLY

Self-Tapping Screws
1 1/4" Long

D SECURING THE CABLES

Cable Ties
(Model 120897R has three cable ties)

Cable Clamp



IMPORTANT

RULES FOR SAFE OPERATION



THIS SYMBOL POINTS OUT IMPORTANT SAFETY INSTRUCTIONS WHICH, IF NOT FOLLOWED, COULD ENDANGER THE PERSONAL SAFETY AND/OR PROPERTY OF YOURSELF AND OTHERS. READ AND FOLLOW ALL INSTRUCTIONS IN THIS MANUAL BEFORE ATTEMPTING TO OPERATE YOUR LAWN MOWER. FAILURE TO COMPLY WITH THESE INSTRUCTIONS MAY RESULT IN PERSONAL INJURY. WHEN YOU SEE THIS SYMBOL—



HEED ITS WARNING.



DANGER

Your lawn mower was built to be operated according to the rules for safe operation in this manual. As with any type of power equipment, carelessness or error on the part of the operator can result in serious injury. If you violate any of these rules, you may cause serious injury to yourself or others.



TRAINING

1. Read this owner's guide carefully in its entirety before attempting to assemble or operate this machine. Be completely familiar with the controls and the proper use of this machine before operating it. Keep this manual in a safe place for future and regular reference and for ordering replacement parts.
2. Your rotary mower is a precision piece of power equipment, not a plaything. Therefore, exercise extreme caution at all times.
3. Never allow children to operate a power mower. Only persons well acquainted with these rules of safe operation should be allowed to use your mower.
4. Keep the area of operation clear of all persons, particularly small children and pets. Stop engine when they are in the vicinity of your mower to help prevent blade contact or thrown object injury. Although the area of operation should be completely cleared of foreign objects, an object may have been overlooked and could be accidentally thrown by the mower in any direction and cause serious personal injury to the operator or any others allowed in the area.



PREPARATION

1. Thoroughly inspect the area where the equipment is to be used. Remove all stones, sticks, wire, bones and other foreign objects which could be picked up and thrown by the mower in any direction and cause serious personal injury to the operator or any others allowed in the area.
2. Always wear safety glasses or eye shields during operation or while performing an adjustment or repair, to protect eyes from foreign objects that may be thrown from the machine in any direction.
3. Wear sturdy, rough-soled work shoes and close-fitting slacks and shirts to avoid entanglement in the moving parts. Never operate a unit in bare feet, sandals, or sneakers.
4. Check the fuel before starting the engine. Gasoline is an extremely flammable fuel. Do not fill the gasoline tank indoors, while the engine is running, or until engine has been allowed to cool for two minutes after running. Replace gasoline cap securely and wipe off any spilled gasoline before starting the engine as it may cause a fire or explosion.
5. Disengage the self-propelled mechanism or drive clutch on units so equipped before starting the engine.
6. The blade control handle is a safety device. Never attempt to bypass its operation. Doing so makes the safety device inoperative and may result in personal injury through contact with the rotating blade. The blade control handle must operate easily in both directions.
7. Never attempt to make a wheel or cutting height adjustment while the engine is running.
8. Never operate the equipment in wet grass. Always be sure of your footing. A slip and fall can cause serious personal injury. Keep a firm hold on the handle and walk, never run. Mow only in daylight or in good artificial light.



OPERATION

1. Do not change the engine governor settings or overspeed the engine. Excessive engine speeds are dangerous.
2. Do not put hands or feet near or under rotating parts. Keep clear of the discharge opening at all times as the rotating blade can cause injury.
3. Stop the blade when crossing gravel drives, walks or roads.
4. After striking a foreign object, stop the engine, remove the wire from the spark plug, and thoroughly inspect the mower for any damage. Repair the damage before restarting and operating the mower.
5. If the equipment should start to vibrate abnormally, stop the engine and check immediately for the cause. Vibration is generally a warning of trouble.
6. Shut the engine off and wait until the blade comes to a complete stop before removing the grass catcher or unclogging the chute. The cutting blade continues to rotate for a few seconds after the engine is shut off. Never place any part of the body in the blade area until you are sure the blade has stopped rotating.
7. Before cleaning, repairing or inspecting, make certain the blade and all moving parts have stopped. Disconnect the spark plug wire, and keep the wire away from the spark plug to prevent accidental starting.
8. Do not run the engine indoors.
9. Mow across the face of slopes, never up-and-down. Exercise extreme caution when changing direction on slopes. Do not mow excessively steep slopes. Always be sure of your footing. A slip and fall can cause serious personal injury.
10. Never operate mower without proper guards, plates or other safety protective devices in place.
11. Do not operate this mower with the chute door open, unless the complete grass catcher or chute deflector is properly mounted on the mower.



MAINTENANCE AND STORAGE

1. Check the blade and engine mounting bolts at frequent intervals for proper tightness.
2. Keep all nuts, bolts, and screws tight to be sure the equipment is in safe working condition.
3. Never store the equipment with gasoline in the tank inside of a building where fumes may reach an open flame or spark. Allow the engine to cool before storing in any enclosure.
4. To reduce fire hazard, keep the engine free of grass, leaves, or excessive grease.
5. Check the grass catcher bag frequently for wear or deterioration. For safety protection, replace only with new bag meeting original equipment specifications.

ASSEMBLY INSTRUCTIONS

IMPORTANT: This unit is shipped **WITHOUT GASOLINE** or **OIL**. After assembly, service engine with gasoline and oil as instructed in the separate engine manual packed with your unit.

NOTE: Reference to right or left hand side of the mower is observed from the operating position.

Tools Required for Assembly

- (1) Phillips Head Screwdriver
- (1) 1/2" Wrench*
- (1) 7/16" Wrench*
- (1) Flat Blade Screwdriver
- *Or one 6" Adjustable Wrench.

UNPACKING

1. Remove the lawn mower from the carton by opening the top flaps and lifting the unit out. Be careful of the staples. Make certain all parts and literature have been removed from the carton before the carton is discarded.
2. Disconnect and ground the spark plug wire by hooking it into the "V" slot on the engine. Check beneath the deck for any cardboard packaging. Remove if present.
3. Stretch out all control cables and place on the floor. Be careful not to bend or kink the cables at any time during assembly.
4. Remove page four from this manual and lay the contents of the hardware pack on the illustration for identification.

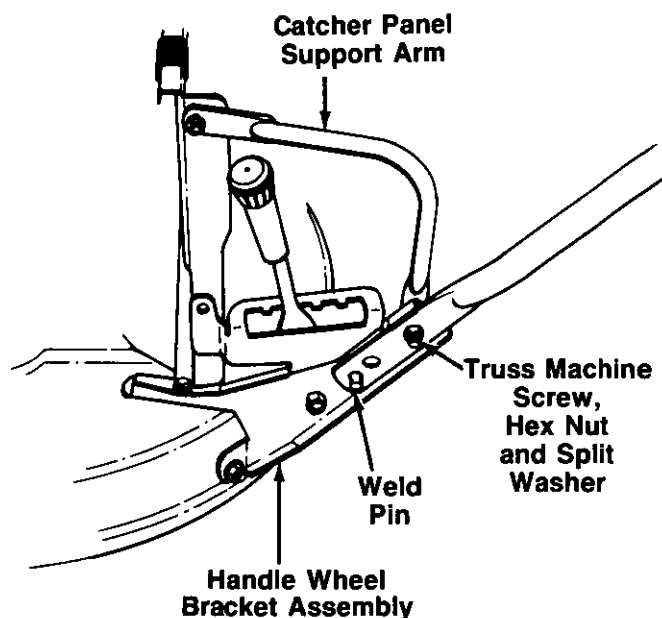

FIGURE 1.

ATTACHING THE LOWER HANDLE (Hardware A)

1. For shipping purposes your mower is set with the wheels in the lowest cutting height position. Raise the mower to the highest setting for assembly of lower handle.
2. On the left side of the mower, remove the truss machine screw, hex nut and split washer from the handle wheel bracket assembly as shown in figure 1.
3. Attach the lower handle by placing the bottom holes in the lower handle over the weld pins on the handle wheel bracket assemblies.
4. Pivot catcher panel support arm in position as shown in figure 1. Insert truss machine screw through catcher panel support arm, wheel bracket assembly and handle. Secure using the split washer and hex nut removed in step 2. Tighten securely.
5. Secure the right side of the handle to handle wheel bracket assembly using truss machine screw, 5/16" split washer and hex nut. Tighten securely.

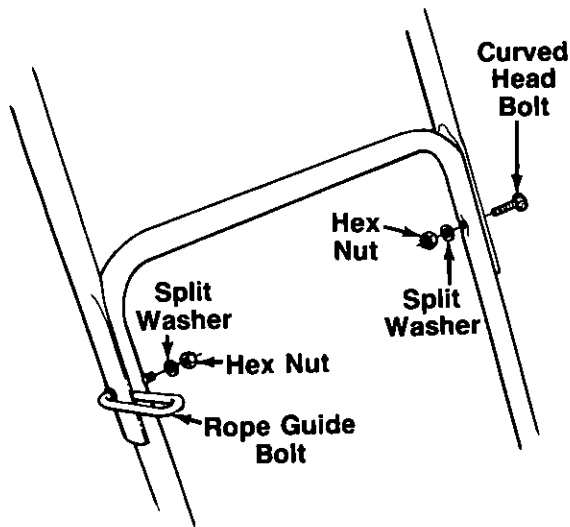

FIGURE 2.

ATTACHING THE UPPER HANDLE (Hardware B)

1. Place the upper handle in position over the lower handle. The label on the throttle control housing and the control lever must be facing up.

NOTE: The right hand side of the handle will be secured with the rope guide bolt. However, left handed operators may assemble the rope guide bolt to the left side of the handle for easier starting by following steps 2 and 3 and reversing the left and right hand instructions.

2. Secure the left hand side of upper handle using the curved head bolt, split washer and hex nut as shown in figure 2.

3. Insert the rope guide bolt through the right hand side of upper and lower handle from the outside in. Secure with split washer and hex nut, finger tight only.

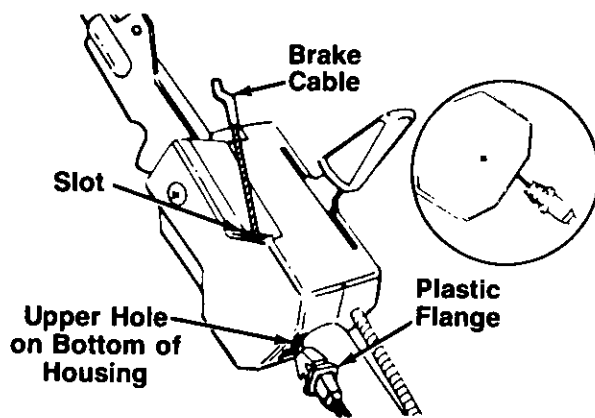

FIGURE 3.

ATTACHING THE BRAKE CABLE

1. The brake cable is attached to the engine, and has a "Z" fitting on the loose end. Route the brake cable in back of the engine, to the outside of the height adjustment handle and handle mounting bracket, and below the lower handle. Place end of cable into the upper hole on the bottom of the control housing, and through the slot as shown. The angle of the plastic flange must be positioned downward as shown in figure 3. Be careful not to bend or kink the cable at any time.

2. Push the plastic fitting until it locks into the control housing.



WARNING: Brake cable must be assembled as shown for proper blade brake operation.

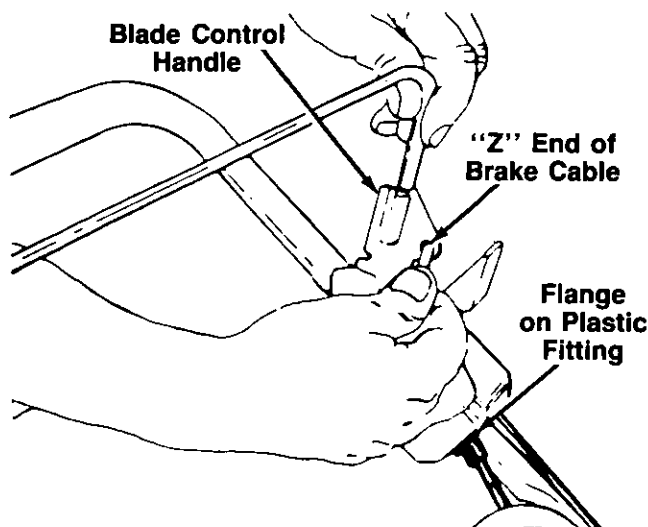

FIGURE 4.

3. Hook the "Z" end of the brake cable into the hole in the blade control handle from the inside to the outside as shown in figure 4.

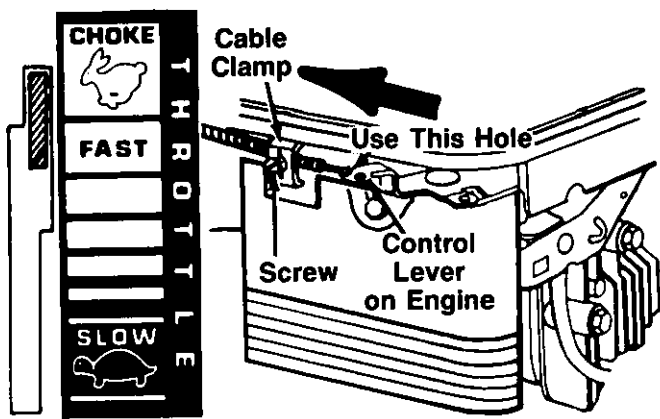

FIGURE 5A.—Model 120898R

ATTACHING THE THROTTLE CABLE

Model 120898R Only:

1. Push the throttle control lever on the handle all the way forward to CHOKE position. See figure 5.
2. The throttle control cable is attached to the upper handle. Route the throttle control cable under the lower handle. Route the cable to the **outside** of the handle wheel bracket assembly and height adjustment lever then in back of the engine. Hook the "Z" end of the throttle control cable into the hole in the control lever on the engine shown in figure 5.
3. Using a screwdriver, remove the screw and cable clamp shown in figure 5.
4. Push the control lever on the engine as far toward the rear of the engine as it will go. Secure the cable in this position with the cable clamp and screw.

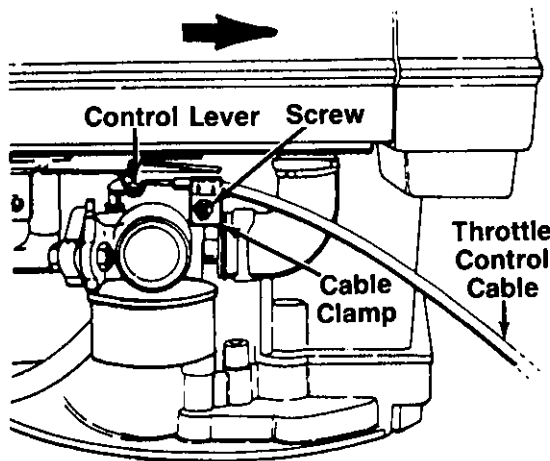

FIGURE 5B.—Model 120899R

ATTACHING THE THROTTLE CABLE

Models 120897R and 120899R:

1. Place the throttle control lever on the handle in FAST position.
2. The throttle control cable is attached to the upper handle. Route the throttle control cable under the lower handle and to the **outside** of the handle wheel bracket assembly and height adjustment lever. Hook the "Z" end of the throttle control cable into the control lever on the engine as shown in figure 5B or 5C.

NOTE: On model 120897R, the control lever is on the right side of the engine. Hook the cable into the lever, from beneath the lever, then push the cable down between the engine and the catcher panel. Make certain the throttle cable does not interfere with the brake cable.

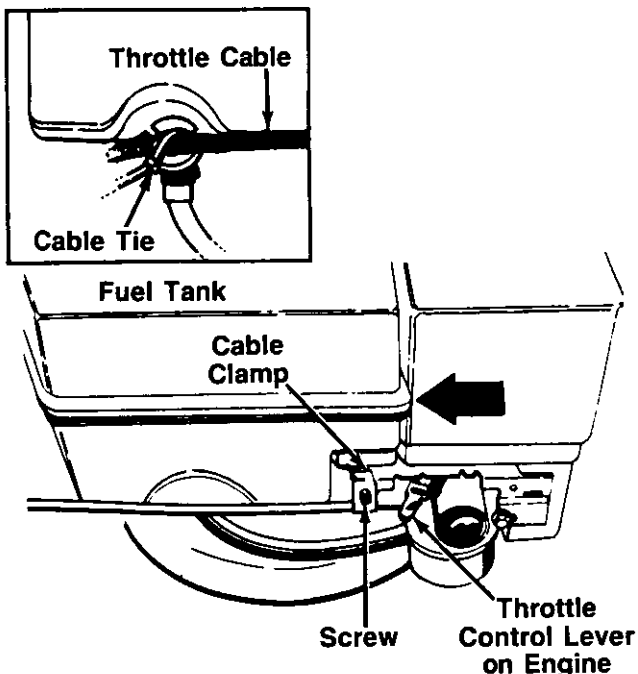

FIGURE 5C.—Model 120897R

3. Loosen (do not remove) the screw on the cable clamp shown in figure 5B or 5C. Slip the control casing under the clamp (cable must move freely beneath the clamp).
4. Place the control lever on the engine in the full open position by pushing it as far toward the rear of the unit as it will go. Tighten the screw on the cable clamp to secure the cable in this position.
5. **Model 120897R only:** Secure the throttle cable to the molded plastic beneath the fuel tank as shown in figure 5C, inset, using a cable tie. Trim excess end of cable tie.

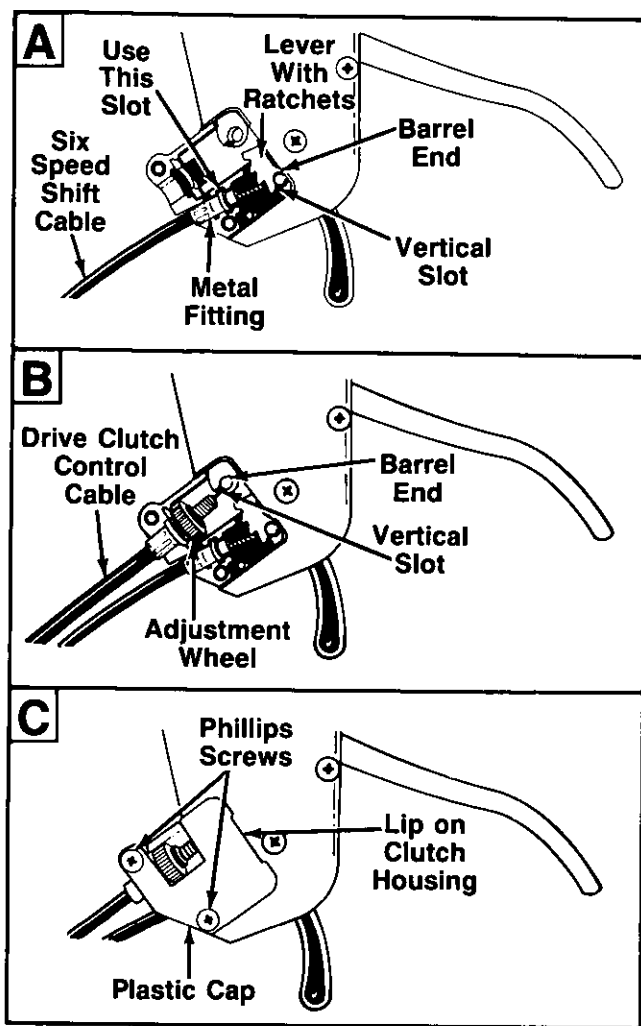

FIGURE 6.—Bottom View

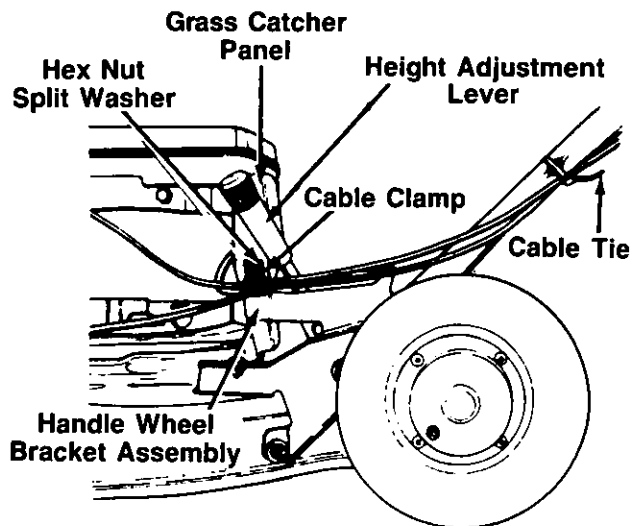

FIGURE 7.

ATTACHING THE SIX SPEED SHIFT CABLE AND DRIVE CLUTCH CONTROL CABLE (Hardware E)

Both the drive clutch cable and the six speed shift cable are attached to the deck. Attach both cables to the underside of the drive clutch control housing, located in the middle of the upper handle.

NOTE: The drive clutch cable is the cable with the adjustment wheel attached.

1. Place the shift lever (located on the bottom of the drive clutch housing) in 1st speed (slow) position.
2. Route the six speed shift cable to the outside of the height adjustment handle and handle mounting bracket. Attach as follows.
 - a. Slide the barrel end of the six speed shift cable into the hole provided in the six speed shift lever (lever with the ratchets). See figure 6A.
 - b. Slip the braided wire into the vertical slot as shown.
 - c. Slide the braided wire around in the horizontal slot.
 - d. Place the metal fitting on the end of the shift cable into the slot in the housing shown in figure 6A. Hold the fitting in this position as you assemble the drive clutch control cable.
3. Assemble the drive clutch control cable as follows.
 - a. Slide the barrel end of the cable into the hole provided in the end of the drive clutch control lever. Slip the braided wire into the vertical slot as shown in figure 6B.
 - b. Slide the braided wire around in the horizontal slot.
 - c. Make certain the adjustment wheel is threaded onto the cable as far as possible as shown in figure 6B. Place the adjustment wheel into the clutch control housing.
4. Secure the plastic cap to the clutch control housing using the two Phillips head screws. See figure 6C.



WARNING: Drive clutch adjustment must be checked before the unit is operated, as described in the operation section.

SECURING THE CABLES (Hardware D)

Attach the brake, throttle control and six speed shift cables to the left handle wheel bracket assembly as follows, using the cable clamp provided.

1. Open the clamp and slip the cables inside.
2. Remove the hex nut and split washer from the side of the left handle wheel bracket assembly as shown in figure 7. Attach the cable clamp to the left hand wheel bracket assembly as shown. Secure with hardware just removed.
3. Place the height adjustment lever in the lowest position.

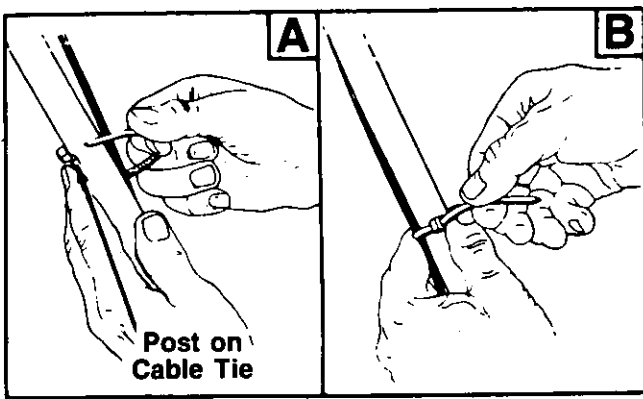

FIGURE 8.

Secure all the control cables to the left side of the handle with the cable ties as follows, taking the slack out of the cables so they do not contact the wheel.

1. Insert posts on cable ties into holes provided on the lower handle, one near the top and one near the bottom of lower handle. The holes may be on either the inside or outside of the handle. See figure 8A.
2. Secure the cables with the cable ties. See figure 8B.
3. Trim excess ends of cable ties.

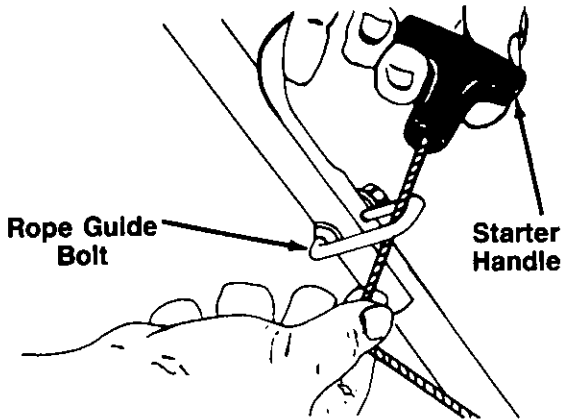

FIGURE 9.

ATTACHING THE STARTER ROPE

1. The starter rope protrudes from the top of the engine. Additional rope may be wound around the starter handle. If so, unwind the rope from the handle.
2. With the spark plug wire disconnected and grounded, depress the blade control handle and pull the rope out of the engine.
3. Slip the starter rope into the rope guide bolt as shown in figure 9.
4. Tighten the hex nut on the rope guide bolt securely.

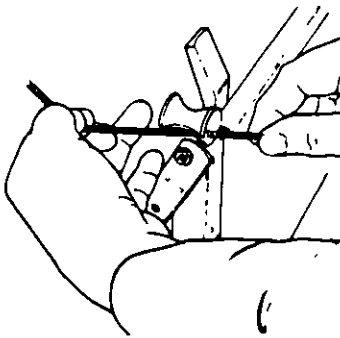

FIGURE 10.

5. If not already assembled, slip the starter rope into the rope guide as shown in figure 10.

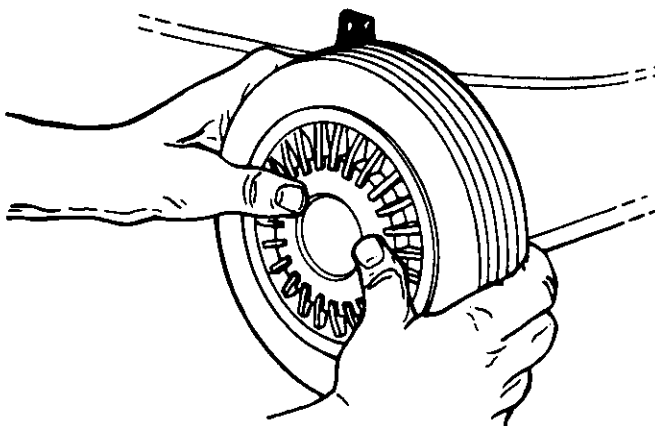

FIGURE 11.

FINAL ASSEMBLY OF MOWER (Hardware F)

1. If plastic plug is needed and is not already assembled, insert plastic plug into hole in the top rear of the deck by slipping one end of plug into hole, then pressing down on the other end of plug. Use a soft hammer if necessary.
2. Place hub caps in position against the inner hub of the wheel. Press firmly around the center portion of hub cap in a circular motion, similar to installing a lid on a round, plastic container. See figure 11. The hub caps are flexible and will snap over the 3½" diameter wheel hubs.
3. Make certain all nuts and bolts are tightened securely.

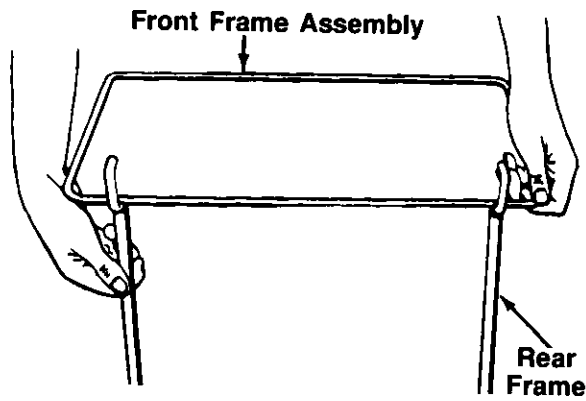

FIGURE 12.

GRASS CATCHER ASSEMBLY (Hardware C)

1. Join the rear frame and front frame assembly as shown in figure 12.

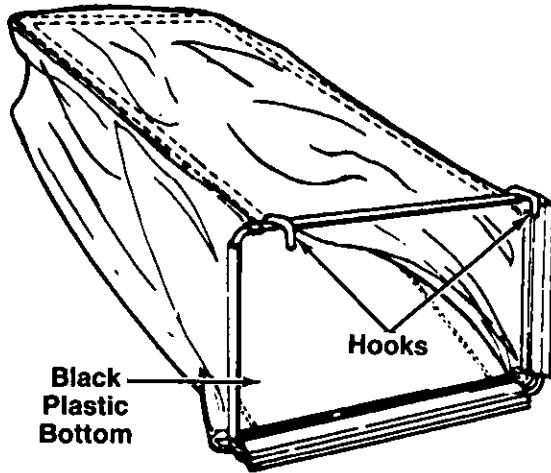

FIGURE 13.

NOTE: Make certain the grass bag is turned right side out before assembling (warning label will be on the outside).

2. Place the frame inside the grass catcher bag. The bottom of the grass bag is black plastic. The hooks on the front frame go toward the top of the bag. See figure 13.

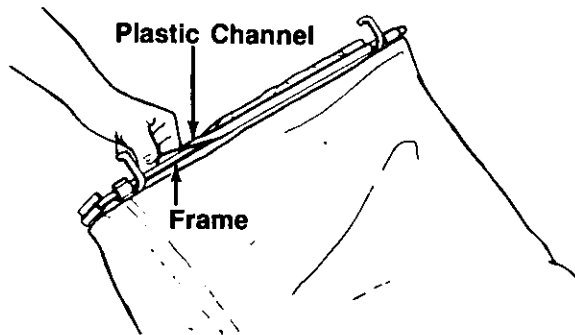

FIGURE 14.

3. Secure front of bag to frame by working the plastic channels on bag over frame. See figure 14.

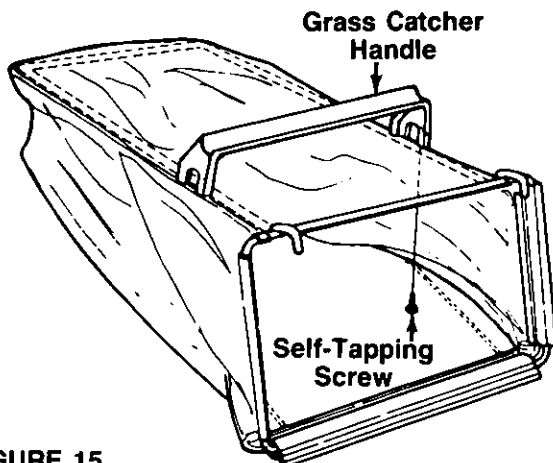

FIGURE 15.

4. Place the grass catcher handle in position on top of the grass bag and frame as shown in figure 15. Secure with four self-tapping screws.

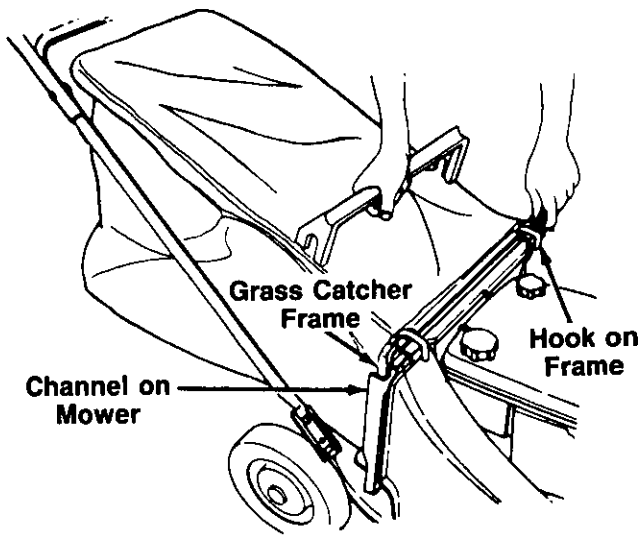

FIGURE 16.

TO ATTACH BAG TO MOWER

1. Hold the chute door on the catcher panel open as shown in figure 16.
2. Slide the frame of the grass catcher down into the channels on each side of the mower. The hooks on the frame go over the panel on the discharge chute. See figure 16.

To remove the grass catcher, lift the grass catcher straight up.

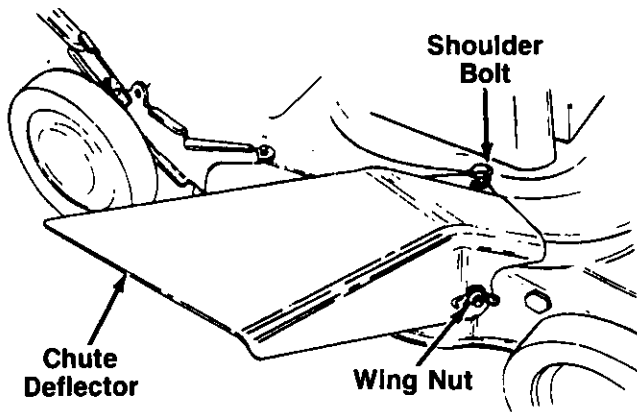

FIGURE 17.

TO CONVERT MOWER TO SIDE DISCHARGE

To convert your mower to a side discharge unit, proceed as follows.

1. Remove the rear discharge chute assembly by removing two wing nuts. Lift up on the two bottom corners of the discharge chute assembly, and slide it off the deck.
2. Attach the side chute deflector by first placing it over the rear bolt in the side of the deck. Then slide the notch in the top of the deflector around the shoulder bolt on top of the deck. Slide the notch in the side of the deflector around the front bolt in the side of the deck. See figure 17.

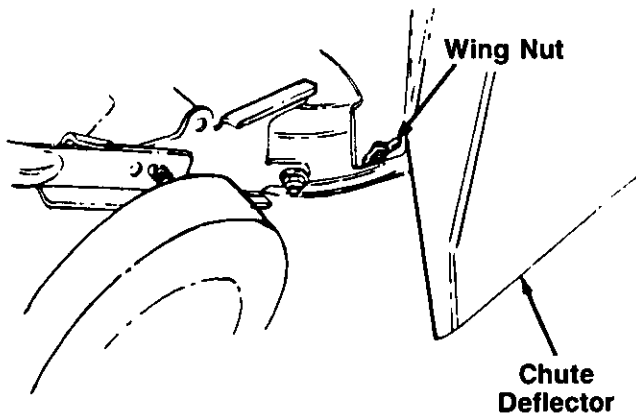

FIGURE 18.

3. Secure the front of the chute deflector to the bolt on the side of the deck with one wing nut. See figure 17. Secure the back of the chute deflector in the same manner. See figure 18.

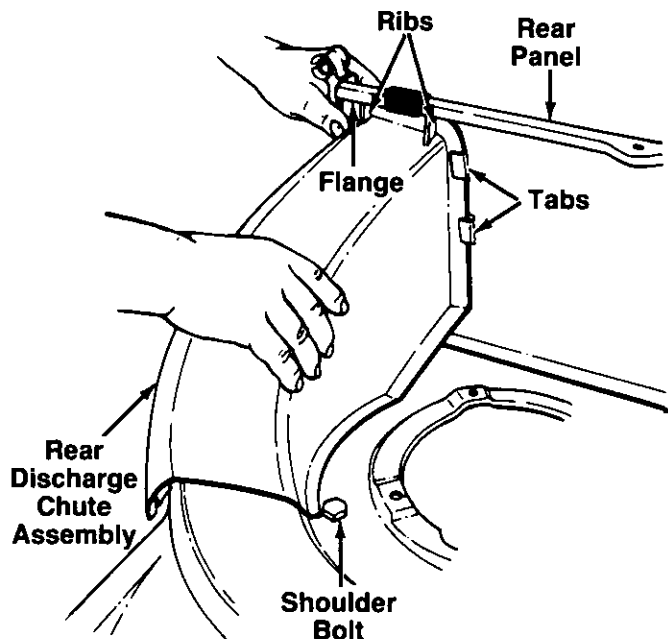

FIGURE 19.



WARNING: Never operate your unit without either the side chute deflector or entire rear discharge chute and grass catcher assembly in place.

To replace the rear discharge chute assembly, proceed as follows.

Slide the ribs on the discharge chute assembly under the flange on rear panel as you insert the side of the discharge chute under the two tabs. See figure 19.

The edge of the discharge chute assembly goes under the shoulder bolt on deck. Push down on the chute assembly, and slide the bottom corner slots over the bolts on side of deck.

Press down on the discharge chute assembly and secure with wing nuts. Make certain wing nuts are seated properly.

CONTROLS

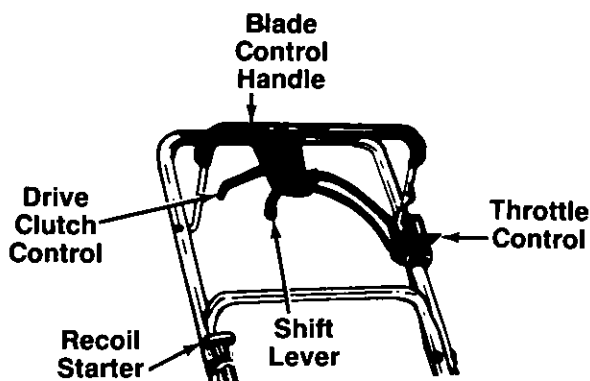

FIGURE 20.

BLADE CONTROL HANDLE

WARNING
THIS CONTROL MECHANISM IS A SAFETY DEVICE NEVER ATTEMPT TO BYPASS ITS OPERATIONS

The blade control handle is located on the upper handle of the mower. See figure 20. The blade control handle must be depressed in order to operate the unit. Release the blade control handle to stop the engine and blade.



WARNING: The blade will be rotating whenever the engine is running.

THROTTLE CONTROL

The throttle control is located on the left side of the upper handle. It is used to regulate the engine speed.



WARNING: The throttle control cannot be used to stop the engine.

RECOIL STARTER

The recoil starter handle is attached to the handle. See figure 20. Stand behind the unit in the operating position to start the unit.

DRIVE CLUTCH CONTROL

Squeezing the drive clutch control engages the drive mechanism to the rear wheels. Releasing the clutch control stops the rear wheels from driving. Release the drive clutch control to slow down when negotiating an obstacle, making a turn or stopping. See figure 20.

SHIFT LEVER

The six speed shift lever is located on the drive clutch control housing on the upper handle. See figure 20. This lever is used to select the operating speed of the mower. Release the drive clutch control when changing speeds.

IMPORTANT: Move the shift lever **ONLY** when the engine is running. Shifting the speeds with the engine off can cause damage to the unit.

OPERATION



FIGURE 21.

Keep hands and feet away from the chute area on cutting deck. See figure 21.

The operation of any lawn mower can result in foreign objects being thrown into the eyes, which can result in severe eye damage. Always wear safety glasses or eye shields. We recommend wide vision safety mask for over spectacles or standard safety glasses.



NOTE: For best results raise the cutting position until it is determined which height is best for your lawn. See cutting height adjustment section.

GAS AND OIL FILL-UP

Service the engine with gasoline and oil as instructed in the separate engine manual packed with your mower. Read instructions carefully.



WARNING: Never fill fuel tank indoors, with engine running or until the engine has been allowed to cool for at least two minutes after running.

BEFORE STARTING

1. Before each use, check for proper drive clutch operation by performing the following before starting the engine:

With the drive clutch control released, push mower forward. It should move freely. Pull mower backward. It should move freely.

If it does not and the rear wheels tend to lock up, the clutch may not be releasing completely. Do not start the engine until corrections have been made.

Check the control cable for severe bend, kinks and binding, or grass build-up in the pulley groove. Correct and adjust as required. Refer to adjustment section for additional information.

2. Attach spark plug wire to spark plug. Make certain the metal loop on the end of the spark plug wire (inside the rubber boot) is fastened securely over the metal tip on the spark plug. See figure 22.

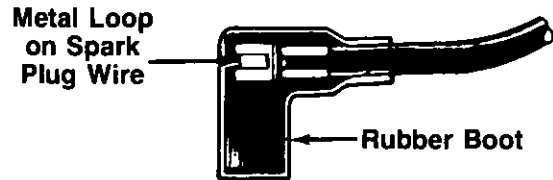

FIGURE 22.

3. **Model 120898R Only:** The fuel shut-off valve is located beneath the fuel tank. The fuel shut-off valve should be in the open position. See figure 23. Open fuel shut-off valve if it is closed.

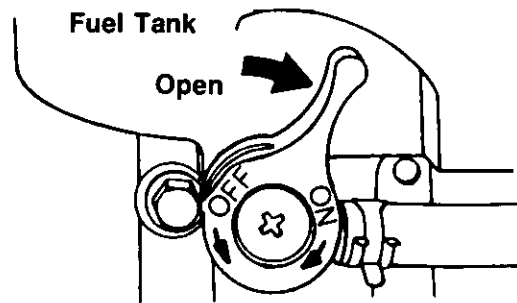

FIGURE 23.—Model 120898R Only

TO START ENGINE AND ENGAGE BLADE

IMPORTANT: Move the shift lever only when the engine is running. Shifting the speeds with the engine off can cause damage to the unit. Disengage the drive clutch control when shifting speeds.



WARNING: When starting the unit for the first time, place mower in first speed (slow) position. Face the mower against a solid object such as a wall, fence, etc. Start the unit, and if it shows any signs of motion with the drive clutch control disengaged, shut the engine off immediately. Make certain the drive clutch control is adjusted so the drive belt is as loose as possible. Refer to the Adjustment Section.

1. **Model 120898R:** Move the throttle control lever to CHOKE position. (A warm engine may not require choking.)

Models 120897R and 120899R: Move the throttle control lever to FAST or START position.

2. **Models 120897R and 120899R:** Prime engine as instructed in the separate engine manual packed with your unit.
3. Standing behind the unit, depress the blade control handle and hold it against the upper handle. Make certain drive clutch control handle is released.
4. Grasp the recoil starter handle and pull back rapidly, extending rope fully. Return it slowly to the rope guide bolt.
5. After engine starts, move throttle control to FAST or desired engine speed.

NOTE: If any problems are encountered, refer to the *Trouble Shooting Guide* on page 19.

WARNING: Never operate your unit without either the side chute deflector or entire rear discharge chute and grass catcher assembly in place.

TO STOP ENGINE AND BLADE

1. Release the blade control handle to stop the engine and blade.

WARNING: The blade continues to rotate for a few seconds after the engine is shut off.

2. Disconnect the spark plug wire and ground it against the engine to prevent accidental starting while equipment is unattended.

USING YOUR ROTARY MOWER

Be sure that lawn is clear of stones, sticks, wire, or other objects which could damage lawn mower or engine. Such objects could be accidentally thrown by the mower in any direction and cause serious personal injury to the operator and others.

For the best results, do not cut wet grass because it tends to stick to the underside of the mower, preventing proper discharge of grass clippings, and could cause you to slip and fall. New grass, thick grass or wet grass may require a narrower cut. Speed of the mower should be adjusted to the condition of the lawn.

When using the side discharge mower, the best mowing pattern is one that allows the clippings to discharge towards the uncut part of the lawn. This permits re-cutting of the clippings to further pulverize them. When cutting high weeds, discharge towards cut portion, then recut at right angles to first direction.

For best results, cut off one-third or less of the total length of the grass. Lawn should be cut in the fall as long as there is growth.

This mower is designed to be operated at full throttle to give you the best cut and do the most effective job of bagging the cut grass.



WARNING: If you strike a foreign object, stop the engine. Remove wire from spark plug, thoroughly inspect the mower for any damage, and repair the damage before restarting and operating the mower. Extensive vibration of the mower during operation is an indication of damage. The unit should be promptly inspected and repaired.

ADJUSTMENTS



WARNING: Do not at any time make any adjustment to lawn mower without first stopping engine and disconnecting spark plug wire.

DRIVE CLUTCH CONTROL ADJUSTMENT

Use the adjustment wheel located on the underside of the clutch control housing to tighten the drive belt if mower does not self-propel with the drive clutch control engaged, or if drive belt is slipping (unit hesitates while engine maintains the same speed). See figure 24.

In addition, the adjustment wheel may also be used to determine the position in which the drive clutch control is engaged. If it is more comfortable to have the drive engaged with the lever further away from the handle, tighten the drive belt.

Make certain to retest the unit for neutral as instructed in the Operation Section. Move the adjustment wheel in the opposite direction to loosen the drive belt if necessary.

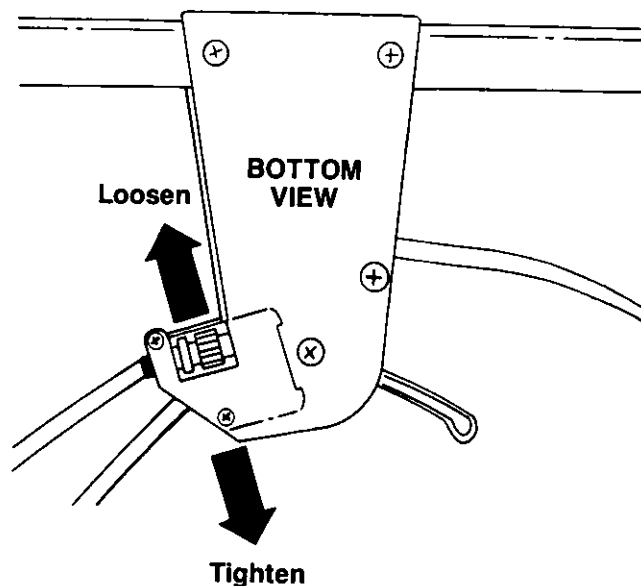

FIGURE 24.

CUTTING HEIGHT ADJUSTMENT

The height adjustment handle is located on the left side of the deck. The handle may be placed in one of nine cutting height positions. Push the handle to the left and then either forward to lower the cutting height or backward to raise the cutting height. See figure 25. For rough or uneven lawns, move the height adjustment handle to a position which will give a higher cutting height.

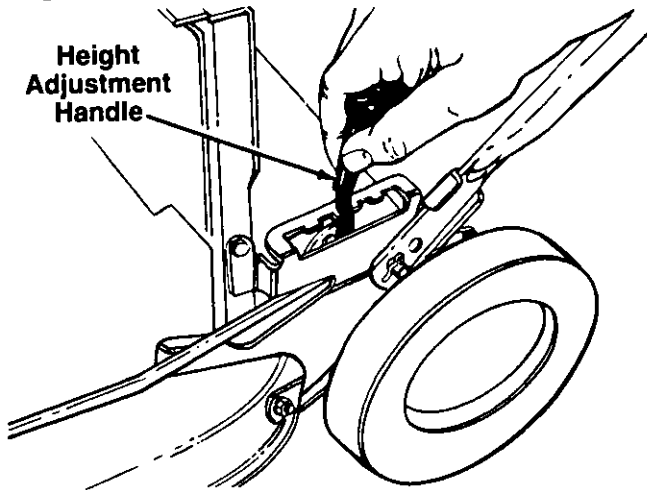

FIGURE 25.
THROTTLE

The throttle control wire assembly can be adjusted if necessary. Remove the screw and cable clamp shown in figure 5. Remove the cable from the clamp. Adjust as instructed in step 4 of "Attaching the Throttle Control Cable" in Assembly Instructions.

SIX SPEED SHIFT CABLE ADJUSTMENT

Periodic adjustment of the six speed shift cable may be required due to normal stretch and wear on the cable. Adjustment is needed if all six speeds cannot be obtained.

The adjustable cable bracket is located on the left side of the mower, beside the engine. To adjust, loosen the hex nut which secures the adjustable cable bracket. See figure 26. Pull backward on the bracket (toward the rear of the mower). Retighten the hex nut. Test the speeds on the mower (engine **must** be running).

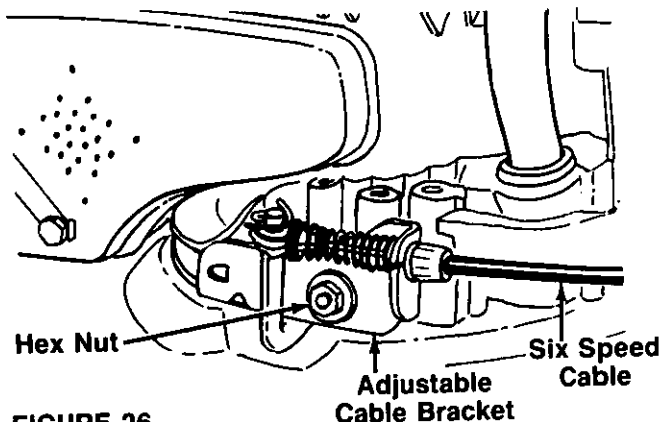

FIGURE 26.

CARBURETOR ADJUSTMENTS



WARNING: If any adjustments are made to the engine while the engine is running (e.g. carburetor), keep clear of all moving parts. Be careful of heated surfaces and muffler.

Minor carburetor adjustment may be required to compensate for differences in fuel, temperature, altitude and load. Refer to the separate engine manual packed with your mower for carburetor adjustment information.

NOTE: A dirty air cleaner will cause an engine to run rough. Be certain air cleaner is clean and attached to the carburetor before adjusting carburetor.

LUBRICATION



WARNING: Always stop engine and disconnect spark plug wire before cleaning, lubricating or doing any kind of work on lawn mower.

Blade Control—Lubricate the pivot points on the blade control handle and the brake cable at least once a season with light oil. See figure 27. The blade control must operate freely in both directions.

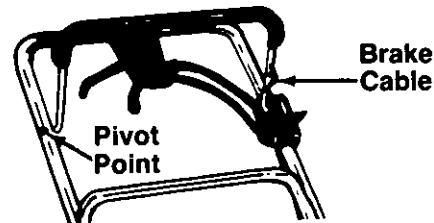

FIGURE 27.

Wheels—Lubricate the wheel bearings at least once a season with light oil. Also, if the wheels are removed for any reason, lubricate the surface of the axle bolt and the inner surface of the wheel with light oil. A 4 oz. plastic bottle of light oil lubricant is available. Order part number 737-0170. Engine oil may also be used.

Engine—Follow engine manual for lubrication instructions.

Throttle—Periodically lubricate throttle control lever and throttle wire assembly with a few drops of light oil for ease of operation.

Transmission—The transmission is pre-lubricated and sealed at the factory. It does not require checking. If disassembled for any reason, fill with 2 ounces of Alvania grease, part number 737-0168.

MAINTENANCE



WARNING: Be sure to disconnect and ground the spark plug wire before performing any repairs or maintenance.

NOTE: When tipping the unit, empty the fuel tank and keep engine spark plug side up.

TROUBLE SHOOTING

Refer to page 19 of this manual for trouble shooting information.

CUTTING BLADE

When removing the cutting blade for sharpening or replacement, protect hands by using heavy gloves or a rag to grasp the cutting blade. Remove the bolt and bell washer which hold the blade and adapter to the engine crankshaft. Remove the blade and adapter from the crankshaft.

If the blade or blade adapter needs replacing, remove the two small bolts, lock washers and nuts which hold the blade to the adapter.



WARNING: Periodically inspect the blade adapter for cracks, especially if you strike a foreign object. Replace when necessary.

When sharpening the blade, follow the original angle of grind as a guide. It is **extremely important** that each cutting edge receives an equal amount of grinding to prevent an unbalanced blade. An unbalanced blade will cause excessive vibration when rotating at high speeds, may cause damage to the mower and could break, causing personal injury.

It is recommended that the blade always be removed from the adapter for the best test of balance. The blade can be tested by balancing it on a round shaft screwdriver. Remove metal from the heavy side until it balances evenly.

Before reassembling the blade and the blade adapter to the unit, lubricate the engine crankshaft and the inner surface of the blade adapter with light oil. Lubricating the bolt holes, bolts and inner surface of the nuts with light oil is also recommended. A 4 oz. plastic bottle of light oil lubricant is available. Order part number 737-0170. Engine oil may also be used.

When replacing the blade, be sure to install the blade with the side of the blade marked "Bottom" (or with part number) facing the ground when the mower is in the operating position.

Blade Mounting Torque

Center Bolt and Blade Adapter Bolts: 375 in. lb. min., 450 in. lb. max.

To insure safe operation of your unit, all nuts and bolts must be checked periodically for correct tightness.

DECK

The underside of the mower deck should be cleaned after each use to prevent a buildup of grass clippings, leaves, dirt or other matter. If this debris is allowed to accumulate, it will invite rust and corrosion, and may cause an uneven discharge of grass clippings at the next cutting.

The deck may be cleaned by tilting the mower and scraping clean with a suitable tool (make certain the spark plug wire is disconnected).

ENGINE

Refer to the separate engine manual for engine maintenance instructions.

Maintain engine oil as instructed in the separate engine manual packed with your unit. Read and follow instructions carefully.

Service air cleaner every 25 hours under normal conditions. Clean every few hours under extremely dusty conditions. Poor engine performance and flooding usually indicates that the air cleaner should be serviced. To service the air cleaner, refer to the separate engine manual packed with your unit.

The spark plug should be cleaned and the gap reset once a season. Spark plug replacement is recommended at the start of each mowing season; check engine manual for correct plug type and gap specifications.

Clean the engine regularly with a cloth or brush. Keep the cooling system (blower housing area) clean to permit proper air circulation which is essential to engine performance and life. Be certain to remove all grass, dirt and combustible debris from muffler area.

BELT REMOVAL AND REPLACEMENT

1. Disconnect the spark plug wire and ground it against the engine.
2. Drain the fuel tank or place a piece of plastic beneath the cap to prevent gasoline leakage.
3. Remove the grass bag, rear discharge chute assembly and catcher panel.
4. Remove the transmission belt cover by removing three bolts. See figure 28.
5. Tip the mower on its side, and block securely.

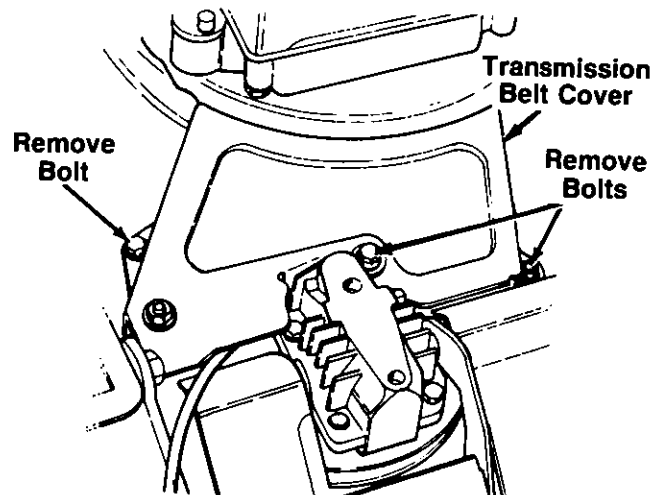

FIGURE 28.

6. Remove the center bolt which secures the blade to the crankshaft. See figure 29. Remove the blade, blade adapter and pulley half. Remove the belt.
7. Remove the inside belt guard by removing two self-tapping screws. A 3/8" wrench is required. See figure 29.

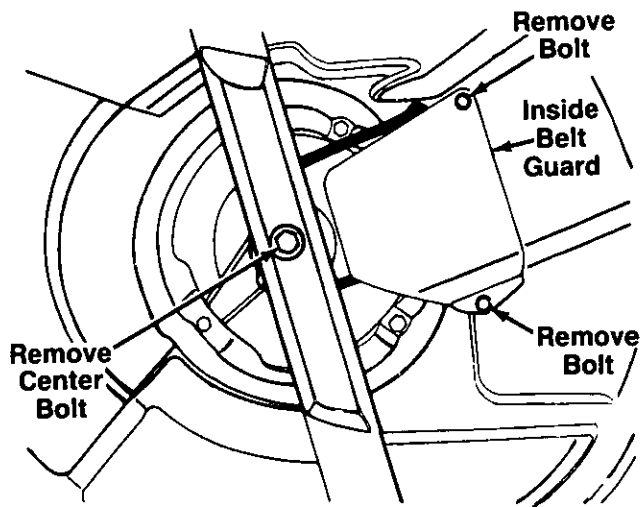

FIGURE 29.

8. Remove the belt from between the idler pulley and the belt guard on the idler pulley bracket. Refer to figure 31.
9. Remove the belt from the transmission pulley.
10. Assemble the new belt as follows.
 - A. Push the idler pulley up out of the way as shown in figure 30.
 - B. Slide the belt in from the rear of the deck, and place it around the transmission pulley. See figure 30.
 - C. Release the idler pulley so it falls down into position. Slide the belt in between the idler pulley and the belt guard on the idler pulley bracket as shown in figure 31.
 - D. Grease the crankshaft. Place belt between the two pulley halves, and reassemble the blade adapter and blade. Reassemble the inside belt guard.
 - E. Reassemble the transmission belt cover, following instructions in step 4 in reverse order.

NOTE: When reassembling the transmission belt cover, be certain the belt guard on the transmission cover is approximately 1/8" away from the belt. Make certain to tighten all nuts and bolts securely. If plastic was placed under the gas cap, be certain to remove it.

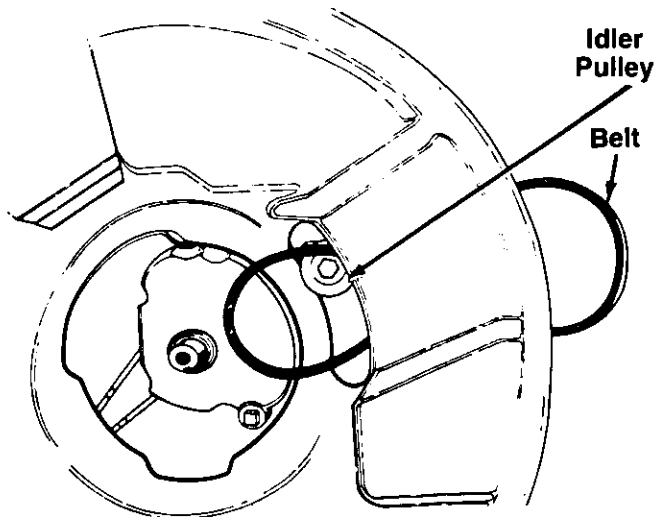

FIGURE 30.

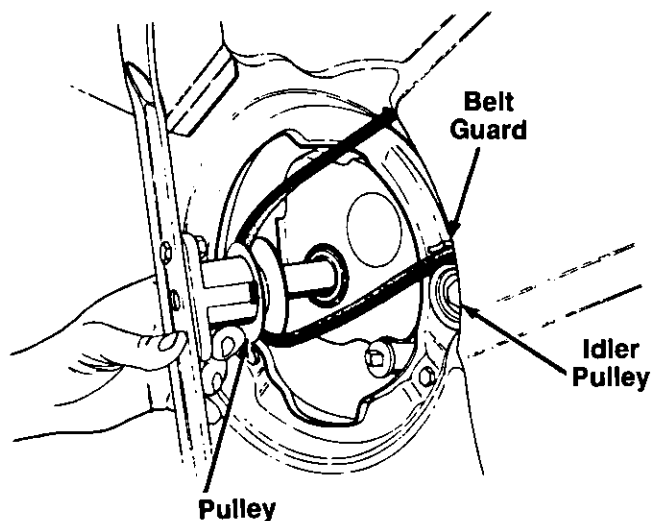

FIGURE 31.

OFF-SEASON STORAGE

The following steps should be taken to prepare lawn mower for storage.

1. Clean and lubricate mower thoroughly as described in the lubrication instructions.
2. Refer to engine manual for correct engine storage instructions.
3. Coat mower's cutting blade with chassis grease to prevent rusting.
4. Store mower in a dry, clean area.

NOTE: When storing any type of power equipment in an unventilated or metal storage shed, care should be taken to rustproof the equipment. Using a light oil or silicone, coat the equipment, especially cables and all moving parts.

Trouble Shooting Guide

Trouble	Possible Cause(s)	Corrective Action
Engine fails to start	<ol style="list-style-type: none"> 1. Blade control handle disengaged. 2. Spark plug wire disconnected. 3. Throttle control lever not in CHOKE position. 4. Fuel shut-off valve closed (if so equipped). 5. Fuel tank empty, or stale fuel. 6. Blocked fuel line. 7. Faulty spark plug. 8. Engine flooded. 	<ol style="list-style-type: none"> 1. Engage blade control handle. 2. Connect wire to spark plug. 3. Move throttle lever to CHOKE position. 4. Open fuel shut-off valve. 5. Fill tank with clean, fresh gasoline. 6. Clean fuel line. 7. Clean, adjust gap or replace. 8. Remove spark plug, dry the plug, and crank engine with plug removed and throttle in off position. Replace spark plug, connect wire and resume starting procedures.
Engine runs erratic	<ol style="list-style-type: none"> 1. Unit running in CHOKE position. 2. Spark plug wire loose. 3. Blocked fuel line or stale fuel. 4. Vent in gas cap plugged. 5. Water or dirt in fuel system. 6. Dirty air cleaner. 7. Carburetor out of adjustment. 	<ol style="list-style-type: none"> 1. Move throttle lever to FAST position. 2. Connect and tighten spark plug wire. 3. Clean fuel line; fill tank with clean, fresh gasoline. 4. Clear vent. 5. Drain fuel tank. Refill with fresh fuel. 6. Clean air cleaner.† 7. Adjust carburetor.†
Engine overheats	<ol style="list-style-type: none"> 1. Engine oil level low. 2. Air flow restricted. 3. Carburetor not adjusted properly. 	<ol style="list-style-type: none"> 1. Fill crankcase with proper oil. 2. Remove blower housing and clean.† 3. Adjust carburetor.†
Occasional skip (hesitates) at high speed	<ol style="list-style-type: none"> 1. Spark plug gap too close. 2. Carburetor idle mixture adjustment improperly set. 	<ol style="list-style-type: none"> 1. Adjust gap to .030". 2. Adjust carburetor.†
Idles poorly	<ol style="list-style-type: none"> 1. Spark plug fouled, faulty or gap too wide. 2. Carburetor improperly adjusted. 3. Dirty air cleaner. 	<ol style="list-style-type: none"> 1. Reset gap to .030" or replace spark plug. 2. Adjust carburetor.† 3. Clean air cleaner.†
Excessive vibration	<ol style="list-style-type: none"> 1. Cutting blade loose or unbalanced. 2. Bent cutting blade. 	<ol style="list-style-type: none"> 1. Tighten blade and adapter. Balance blade. 2. Replace blade.
Mower will not discharge grass	<ol style="list-style-type: none"> 1. Engine speed too low. 2. Wet grass. 3. Excessively high grass. 	<ol style="list-style-type: none"> 1. Set throttle between 3/4 and full throttle. 2. Do not mow when grass is wet; wait until later to cut. 3. Mow once at a high cutting height, then mow again at desired height or make a narrower cutting swath (1/2 width).
Uneven cut	Dull blade.	Sharpen or replace blade.

†Refer to separate engine manual packed with your unit.

Note: For repairs beyond the minor adjustments listed above, contact your local authorized service dealer.

120897R, 120898R and 120899R

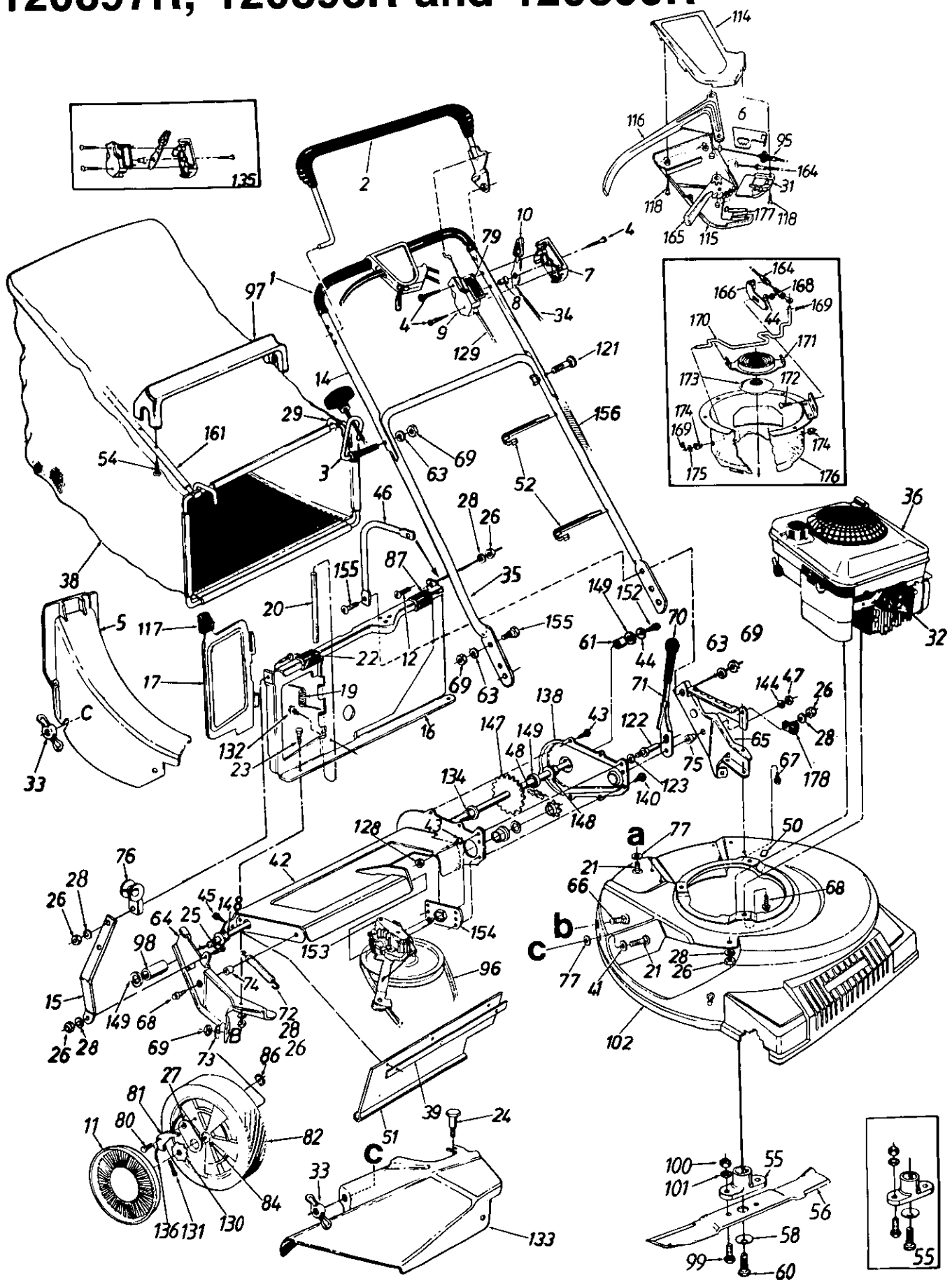

120897R, 120898R and 120899R

PARTS LIST FOR 21" ROTARY MOWERS

REF. NO.	PART NO.	CODE	DESCRIPTION	REF. NO.	PART NO.	CODE	DESCRIPTION
1	720-0225		Grip (2 Req'd.)	56	742-0306A		21" Blade
2	731-0609		Control Handle Ass'y.—L.H.	58	736-0453		Bell-Wash. .46" I.D.
3	710-0842B		Rope Guide Bolt	60	710-0757		Hex Bolt 7/16-20 x 1.5"
4	710-0796		Truss Mach. Scr. #12 x 1.50" Lg.	61	748-0190		Spacer .513" I.D.
5	731-1024	N	Rear Discharge Chute Ass'y.	63	736-0119		L-Wash. 5/16" I.D.*
6	713-0397	N	3 Tooth Rack Gear Insert	64	16136A		R.H. Handle Wheel Brkt. Ass'y.
7	731-0817A		Control Panel Half	65	16137B		L.H. Handle Wheel Brkt. Ass'y.
8	731-0524		Control Disc Pin	66	710-0260		Carriage Bolt 5/16-18 x .62"*
9	731-0816A		Clutch Panel Half	67	710-0603		Hex B-Tap Scr. 5/16-18
10	731-0972		Throttle Control Lever	68	710-0654A		Hex TT-Tap Scr. 3/8-16
11	731-0982A		Hub Cap	69	712-0267		Hex Nut 5/16-18 Thd.*
12	710-0946		Truss Mach. Scr. 1/4-20 x .62" Lg.	70	720-0223		Grip
14	749-0439A		Upper Handle	71	732-0606		Height Adj. Lever
15	16129A		Panel Support Brkt.	72	732-0481		Extension Spring 3.80" Lg.
16	16862		Rear Catcher Panel Ass'y.	73	736-0242		Bell-Wash. 5/16" I.D.
17	17095		Rear Discharge Door	74	750-0736		Spacer .383" I.D.
19	732-0483A		Torsion Spring	75	750-0624		Shld. Spacer .5" Dia.
20	747-0514		Pivot Pin	76	719-0279		Rope Guide
21	710-0134		Carriage Bolt 1/4-20 x .62"*	77	726-0233		Bolt Retainer 1/4 x .50" O.D.
22	710-0255		Truss Mach. Scr. 1/4-20 x .75" Lg.	79	777-5812		Control Label
23	710-0289		Hex Bolt 1/4-20 x .5" Lg.	80	738-0137		Shld. Scr. .342" Dia. x .268
24	738-0704		Shoulder Bolt Special	81	748-0188B		Pawl
25	710-0258		Hex Bolt 1/4-20 x .62" Lg.	82	734-1514A		Wheel Ass'y. Comp.—Rear
26	712-0287		Hex Nut 1/4-20 Thd.*	84	741-0486B		Sleeve Bearing 1/2" I.D.
27	16855		Pawl Plate	86	712-0189		Flat Nut 1/4-20 Thd.
28	736-0329		L-Wash. 1/4" I.D.*	87	731-0880		Panel Clip
29	747-0705		Front Grass Catcher Frame	95	746-0710		S.P. Cable—50" Lg.
31	731-0906	N	S.P. Control Cover	96	754-0343		"V"-Belt
32	735-0639		Spark Plug Insulator	97	731-0801		Bag Handle
33	712-0388		Wing Nut	98	711-0313		Sleeve .526" I.D.
34	746-0674		Throttle Control Wire—61" (120898R)	99	710-1055		Hex Bolt 3/8-24 x 1.0" Lg.
	746-0672		Throttle Control Wire—58" (120897R)	100	712-0241		Hex Nut 3/8-24 Thd.
	746-0640		Throttle Control Wire—45" (120899R)	101	736-0169		L-Wash. 3/8" I.D.
35	749-0725		Lower Handle	102	17051	638	21" Deck Ass'y.
36	—		Engine	114	731-0904	N	Self-Propelled Control Cover
38	746-0262		Grass Bag	115	731-0905	N	Self-Propelled Control Cover
39	14835		Retaining Strip	116	731-0620		Control Lever
41	736-0204		Fl-Wash. .344" I.D. x .62"	117	720-0190		Door Grip
42	17055B		Chain—Axle Ass'y.	118	710-0841		Fl-"C"-Sunk Hd. Tap Scr. #10 x .75" Lg.
43	710-0352		Hex B-Tap Scr. 1/4" x .38"	121	710-0671		Curved Carr. Bolt 5/16-18 x 1.38" Lg.
44	736-0270		Bell-Wash. 1/4" I.D.	122	711-0805		Shld. Pin 1.43" Lg.
45	710-0776A		Hex AB-Tap Scr. 1/4 x .62"	123	736-0169		L-Wash. 3/8" I.D.
47	712-0296		Hex Patch L-Nut 3/8-24 Thd.	128	712-0711		Hex Jam Nut 3/8-24 Thd.*
48	713-0353		#48 Chain .500" Pitch x 30 Links	129	746-0477A		Control Cable—39" (120898R)
50	731-0564		Plug		746-0479A		Control Cable—55" (120897R)
51	731-0672A		Rear Flap 3.75" x 17.30" Lg.		746-0482		Control Cable—58" (120899R)
52	726-0240		Cable Tie	130	748-0318		Ratchet Wheel 1.62" O.D.
54	710-1025		Hex AB-Tap Scr. #12 x 1.25" Lg.	131	714-0115		Cotter Pin 1/8" Dia. x 1"*
55	753-0485		Blade Adapter Kit	132	710-0429		Hex B-Tap Scr. #10 x .38" Lg.
				133	731-0885	638	Side Chute Deflector Ass'y.
				134	741-0522		Hex Flange Bearing
				135	753-0430		Kit—Control Housing Comp.
				136	10622B		Spring—Nylon
				138	17053A		Chain Cover
				140	710-0599		Hex S-Tap Scr. 1/4-20 x .50"

120897R, 120898R and 120899R

PARTS LIST FOR 21" ROTARY MOWERS (CONTINUED)

REF. NO.	PART NO.	CODE	DESCRIPTION	REF. NO.	PART NO.	CODE	DESCRIPTION
144	736-0300		Fl-Wash. .385" I.D. x .87"	165	731-0924	N	6-Spd. Shift Lever
147	738-0719A		Rear Shaft Ass'y. 21.94" Lg.	166	17070	N	Adjustable Cable Brkt.
148	741-0324		Hex Flange Brg. .506" I.D.	168	712-0291		Hex Cent. L-Nut 1/4-20 Thd.
149	736-0160		Fl-Wash. .531" I.D. x .930"	169	714-0507		Cot-Pin 3/32" Dia. x .75" Lg.
152	710-0751		Hex Bolt 1/4-20 x .62" Lg. (Grade 5)	170	747-0684	N	Shift Rod
153	717-0417B	N	Transmission Comp. (See Breakdown)	171	741-0500	N	Movable Pulley Half Ass'y.
154	16500A		Hex Bearing Cup	172	710-0167		Carr. Bolt 1/4-20 x .5" Lg.
155	710-0323		Truss Mach. Scr. 5/16-18 x .75" Lg.	173	756-0503		Splined Pulley Half
156	731-0759		Plastic Tubing	174	731-1137	N	Flanged Bushing
164	746-0706	N	Spd. Control Cable—50" Lg.	175	736-0278		Fl-Wash. .328" I.D. x .68" O.D.
				176	17073	N	Cable Mtg. Brkt. Ass'y.
				177	732-0627	N	Shift Lever Spring
				178	726-0175		Clamp

*For faster service obtain standard nuts, bolts and washers locally. If these items cannot be obtained locally, order by part number and size as shown on parts list.

CODE: N notates a new part (not previously existing). A three digit number is the **color code** (use if color or finish is important when ordering parts). See chart at right. [i.e., (part no.)-638 for Red Finish].



This instruction manual covers various models, and all specifications shown do not necessarily apply to your model. Specifications subject to change without notice or obligation.

NOTE: The engine is not under warranty by the mower manufacturer. . . If repairs or service is needed on the engine, please contact your nearest authorized engine service outlet. Check the "Yellow Pages" of your telephone book under "Engines—Gasoline."



120897R, 120898R and 120899R

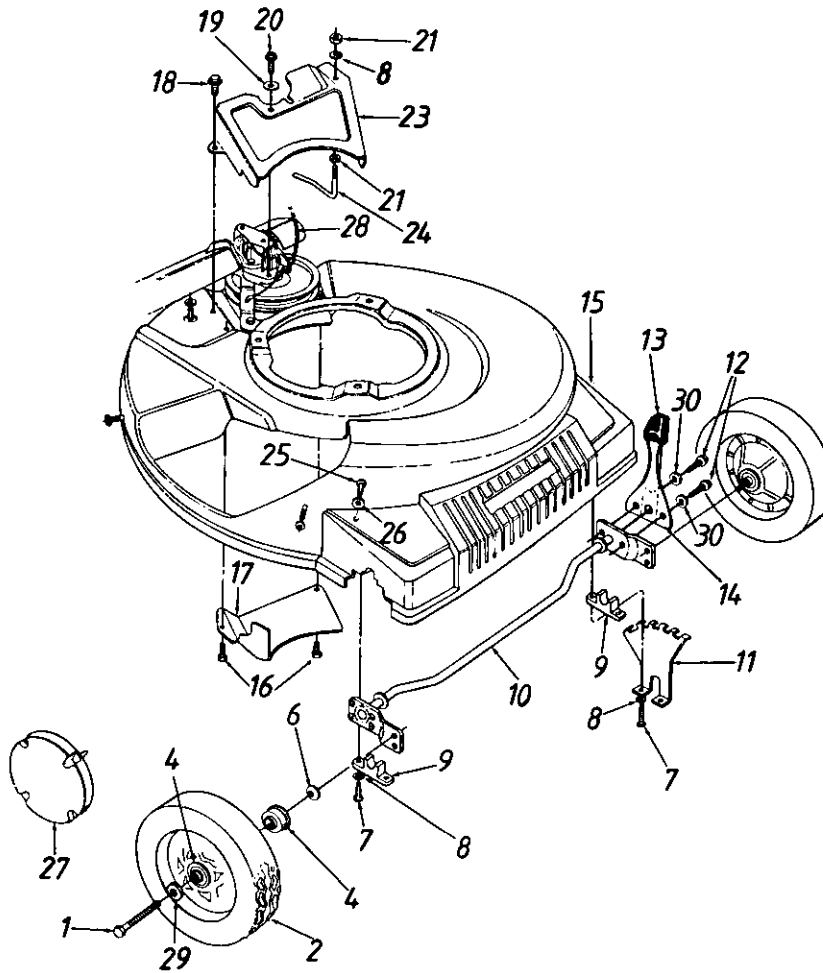

PARTS LIST FOR 21" ROTARY MOWERS

REF. NO.	PART NO.	CODE	DESCRIPTION	REF. NO.	PART NO.	CODE	DESCRIPTION
1	738-0102		Front Axle Bolt	17	17065A	N	Belt Cover
2	734-1517A		Wheel Ass'y. Comp. 8 x 2"	18	710-0599		Hex Wash. Hd. TT-Scr. 1/4-20
4	741-0180		Flange Ball Brg. .501" I.D.	19	736-0270		Bell-Wash. .265" I.D. x .75"
6	736-0105		Bell-Wash. .380" I.D. x .88	20	710-0896		Hex Wash. Hd. B-Tap Scr.
7	710-0588		Hex Wash. Hd. B-Tap Scr. 1/4-20	21	712-0287		Hex Nut 1/4-20 Thd.*
8	736-0329		L-Wash. 1/4" I.D.*	23	17058A		Transmission Belt Guard
9	741-0492		Block Bushing	24	747-0549		S.P. Belt Guard
10	17060	N	Axle Ass'y.	25	710-1001		Truss B-Tap Scr. 5/16 x .75"
11	17059		Height Adj. Bracket	26	736-0242		Bell-Wash. .345" I.D. x .88" O.D.
12	710-0653		Hex Wash. Hd. TT-Tap Scr. 1/4-20 x .38" Lg.	27	731-0982A		Hub Cap
13	720-0190		Knob	28	746-0710		S.P. Cable 50" Lg.
14	732-0553		Spring Lever	29	736-0232		Wave Wash. .53" I.D. x .78" O.D.
15	731-0865		Plastic Front End	30	736-0222		External L-Wash. 1/4" I.D.
16	710-0352		Hex B-Tap Scr. 1/4" x .38"				

120897R, 120898R and 120899R

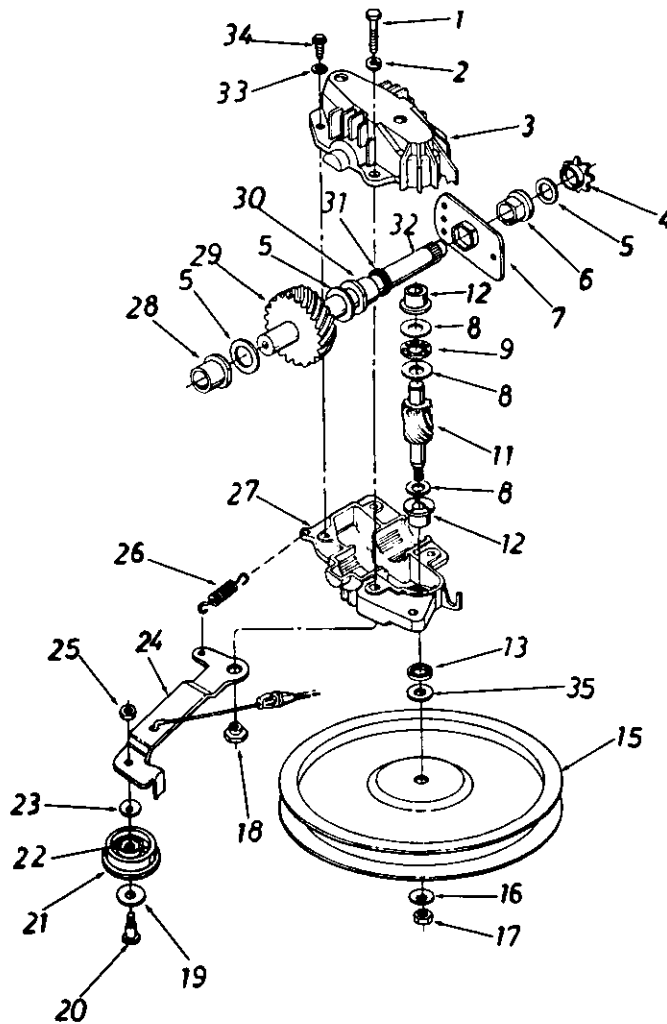

PARTS LIST FOR 21" ROTARY MOWERS

REF. NO.	PART NO.	CODE	DESCRIPTION	REF. NO.	PART NO.	CODE	DESCRIPTION
1	710-1062		Hex Bolt 1/4-20 x 1.25" Lg.*	18	738-0440		Shld. Spacer .375" Dia. x .170"†
2	736-0329		L-Wash. 1/4" I.D.*	19	736-0344		FI-Wash. .390" I.D. x 1.0"†
3	717-0418A		Upper Hsg. Half	20	738-0826	N	Shld. Bolt .375" Dia. x .40"†
4	713-0400		#48 Sprocket 7 Tooth x 1/2 Pitch	21	756-0558	N	FI-Idler Plastic 1.50" Dia.†
5	736-0336		FI-Wash. 5/8" I.D. x .030	22	741-0556	N	Needle Brg. .375" x .31"†
6	741-0413		Hex Flange Brg. .631" I.D.	23	736-0270		Bell-Wash. .265" I.D. x .75"†
7	16500A		Hex Bearing Cup	24	17052A		Idler Brk't. Ass'y.†
8	736-0314		Thrust Wash. .382" I.D. x .70" O.D.	25	712-0138		Hex Patch L-Nut 1/4-28 Thd.†
9	741-0479		Thrust Bearing .375" I.D. x .812" O.D.	26	732-0357		Extension Spring 1.12" Lg.†
11	717-1216		11 Tooth Pinion Shaft	27	717-0419A		Lower Hsg. Half
12	748-0208A		Flange Bearing	28	741-0415		Flange Bearing .566 Dia.
13	721-0212		Oil Seal	29	717-0422A		33 Tooth Helical Gear
15	756-0330A		FI-Pulley 5.06" O.D.†	30	741-0414		Flange Bearing .629 Dia.
16	736-0270		Bell-Wash. .265" I.D. x .75"†	31	721-0213		Oil Seal .625 Dia.
17	712-0351		Hex L-Nut 1/4-28 L.H. Thd.†	32	738-0607A		Gear Sprocket Shaft
				33	736-0722		L-Wash. #10 I.D.
				34	710-0436		Hex B-Tap Scr. #10 x .62"
				35	736-0410		Hex Washer .26" x .88"†
				—	717-0417B	N	Transmission Comp.

†Not Part of Transmission Complete



YARD-MAN PARTS INFORMATION

POWER EQUIPMENT PARTS AND SERVICE

Parts and service for all YARD-MAN manufactured power equipment are available through local Authorized Service Dealers. Check the yellow pages. All orders should specify the model number of your unit, part numbers, description of parts and the quantity of each part required. **DO NOT SEND PARTS ORDERS TO FACTORY.** Service Distributors listed below, identified by state abbreviation, may be contacted for service assistance.

NC ALLISON-ERWIN CO.
SC 2920 N. Tryon Street
P.O. Box 32308
Charlotte, NC 28232
(704) 334-8621

C-CA ALL SEASON EQUIPMENT
169 S. Hewes Street
Orange, CA 92669
(714) 639-7272

S-CA BILLIOUS
75 N "D" Street
Porterville, CA 93257
(209) 784-4102

N-CA BLISS POWER LAWN
NV EQUIPMENT
101 Commerce Circle
Sacramento, CA 95815
(916) 925-6936

ME M. L. COFFIN CO.
NH 725 Broadway
VT Bangor, ME 04401
(207) 942-8289

MS DICKERSON DISTRIBUTORS,
AL INC.
N-GA P.O. Drawer 231
127 N. W. Depot
Durant, MS 39063
(601) 653-3004

S-FL FLORIDA TURF & GARDEN
EQUIPMENT
7275 NW 64th St.
Miami, FL 33166
(305) 592-3846

UP-NY GAMBLE DISTRIBUTING INC.
P.O. Box 389
West End Ave.
Carthage, NY 13619
(315) 493-2270

MI IDEAL MOWER SALES
811 Woodward Heights
Ferndale, MI 48220
(313) 541-4660

C-FL MANLEY TRACTOR SALES
5909 E. Broadway
Tampa, FL 33619
(813) 626-5900

IN McDONOUGH & ASSOCIATES
8535 E. 30th St.
P.O. Box 1915
Indianapolis, IN 46219
(317) 898-4200

WI MERCOR CORP.
4080 N. Pt. Washington Rd.
P.O. Box 12145
Milwaukee, WI 53212
(414) 961-3200

NJ DE NIEMEYER CORP.
NY MD 1135 Phoenixville Pike
PA P.O. Box 1477
WA-DC West Chester, PA 19380
(215) 431-7200

MN NORTHSTAR OUTDOOR
IA EQUIPMENT CORP.
ND Hwy. 25 & 18, P.O. Box 764
SD Brainerd, MN 56401
(218) 829-4271

MO OZARK EQUIPMENT CO.
E-KS Hwy. 63 & Black Street
Rolla, MO 65401
(314) 364-2180

IL PLANTE'S LAWN & GARDEN
4 Grant St.
N. Aurora, IL 60542
(312) 892-2220

N-FL POWER EQUIP. DIST. INC.
S-GA 565 S. Edgewood Ave.
S-AL Jacksonville, FL 32205
(904) 387-1512

UT MT POWERED PRODUCTS
WY S-ID 1661 N. Beck St.
Salt Lake City, UT 84116
(801) 359-9767

OH RAHRIG SALES INC.
108-110 W. Lima St.
Forest, OH 45843
(419) 273-2556

KY RASCHE CYCLE CO.
TN 713 Kentucky Ave.
Paducah, KY 42001
(502) 443-8142

C-FL SPAULDINGS INC
P.O. Box 10009
1921 5th Ave S.
St. Petersburg, FL 33712
(813) 896-2611

CO SPITZER INDUSTRIAL PRODUCTS
6601 N. Washington Street
Denver, CO 80229
(303) 287-3414

AR TIMBERLAND SAW CO.
LA Hwy. 31 South
OK P.O. Box 1227
TX Marshall, TX 75671
(214) 935-5251

CANADA MTD PRODUCTS CANADA
97 Kent Ave.
Kitchener, Ontario
Canada, N2G 4J1
(519) 579-5500

EXPORT DRAKE AMERICA CORP.
#2 Gannett Drive
White Plains, NY 10604
(914) 697-9800

WARRANTY PARTS AND SERVICE POLICY

(0889)

The purpose of warranty is to protect the customer from defects in workmanship and materials, defects which are NOT detected at the time of manufacture. It does not provide for the unlimited and unrestricted replacement of parts. Use and maintenance are the responsibility of the customer. The manufacturer cannot assume responsibility for conditions over which it has no control. Simply put, if it's the manufacturer's fault, it's the manufacturer's responsibility; if it's the customer's fault, it's the customer's responsibility.

CLAIMS AGAINST THE MANUFACTURER'S WARRANTY INCLUDES:

1. Replacement of Missing Parts on new equipment.
2. Replacement of Defective Parts within the warranty period.
3. Repair of Defects within the warranty period.

All claims MUST be substantiated with the following information:

1. Model Number, Serial Number and/or Date Code of unit involved.
2. Date unit was purchased or first put into service.
3. Date of failure—Date Repaired.
4. Nature of failure—Correction.