



Operator's Manual



20" Mulching Push Mower

Model

11A-108Q401

IMPORTANT: Read safety rules and instructions carefully before operating equipment.

Warning: This unit is equipped with an internal combustion engine and should not be used on or near any unimproved forest-covered, brush-covered or grass-covered land unless the engine's exhaust system is equipped with a spark arrester meeting applicable local or state laws (if any). If a spark arrester is used, it should be maintained in effective working order by the operator. In the State of California the above is required by law (Section 4442 of the California Public Resources Code). Other states may have similar laws. Federal laws apply on federal lands. A spark arrester for the muffler is available through your nearest engine authorized service dealer or contact the service department, P.O. Box 368022 Cleveland, Ohio 44136-9722.

MTD PRODUCTS INC. P.O. BOX 368022 CLEVELAND, OHIO 44136-9722

PRINTED IN U.S.A.

FORM NO. 770-10328
(11/99)

TABLE OF CONTENTS

Content	Page
Important Safe Operation Practices.....	3-5
Slope Gauge.....	6
Unpacking.....	7
Assembling Your Lawn Mower.....	7
Know Your Lawn Mower	8
Operating Your Lawn Mower	9
Making Adjustments	10
Service.....	10
Maintaining Your Lawn Mower.....	11
Off-Season Storage	12
Troubleshooting.....	13
Parts List.....	14

FINDING MODEL NUMBER

This Operator's Manual is an important part of your new Lawn Mower. It will help you assemble, prepare and maintain the unit for best performance. Please read and understand what it says.



Before you start assembling your new equipment, please locate the model plate on the equipment and copy the information from it in the space provided below. The information on the model plate is very important if you need help from our Customer Support Department or an authorized dealer.

- You can locate the model number by standing behind the unit in the operating position and looking at the rear of the deck. A sample model plate is explained below. For future reference, please copy the model number and the serial number of the equipment in the space below.

_____	_____
(Model Number)	(Serial Number)



Copy the model number here: _____

Copy the serial number here: _____

CALLING CUSTOMER SUPPORT

If you have difficulty assembling this product or have any questions regarding the controls, operation or maintenance of this unit, please call the Customer Support Department.



Call **1- (330) 220-4MTD (4683)** or **1- (800)-800-7310** to reach a Customer Support representative. Please have your unit's model number and serial number ready when you call. See previous section to locate this information. You will be asked to enter the serial number in order to process your call .

SECTION 1: IMPORTANT SAFE OPERATION PRACTICES



This symbol points out important safety instructions which, if not followed, could endanger the personal safety and/or property of yourself and others. Read and follow all instructions in this manual before attempting to operate your lawn mower. Failure to comply with these instructions may result in personal injury. When you see this symbol, heed its warning.

DANGER: Your lawn mower was built to be operated according to the rules for safe operation in this manual. As with any type of power equipment, carelessness or error on the part of the operator can result in serious injury. This lawn mower is capable of amputating hands and feet and throwing objects. Failure to observe the following safety instructions could result in serious injury or death.



WARNING: The Engine Exhaust from this product contains chemicals known to the State of California to cause cancer, birth defects or other reproductive harm.

GENERAL OPERATION

- Read this operator's manual carefully in its entirety before attempting to assemble this machine. Read, understand, and follow all instructions on the machine and in the manual(s) before operation. Be completely familiar with the controls and the proper use of this machine before operating it. Keep this manual in a safe place for future and regular reference and for ordering replacement parts.
- Your rotary mower is a precision piece of power equipment, not a plaything. Therefore, exercise extreme caution at all times. Your unit has been designed to perform one job: to mow grass. Do not use it for any other purpose.
- Never allow children under 14 years old to operate a power mower. Children 14 years old and over should only operate mower under close parental supervision. Only responsible individuals who are familiar with these rules of safe operation should be allowed to use your mower.
- Keep the area of operation clear of all persons, particularly small children and pets. Stop engine when they are in the vicinity of your mower to help prevent blade contact or thrown object injury. Although the area of operation should be completely cleared of foreign objects, an object may have been overlooked and could be accidentally thrown by the mower in any direction and cause serious personal injury to the operator or any others allowed in the area.
- Wear sturdy, rough-soled work shoes and close-fitting slacks and shirts. Shirts and pants that cover the arms and legs and steel-toed shoes are recommended. Do not wear loose fitting clothes or jewelry. They can be caught in moving parts. Never operate a unit in bare feet, sandals, slippery or light weight (e.g. canvas) shoes.
- Always wear safety glasses or safety goggles during operation or while performing an adjustment or repair, to protect eyes from foreign objects that may be thrown from the machine in any direction.
- Thoroughly inspect the area where the equipment is to be used. Remove all stones, sticks, wire, bones, toys and other foreign objects which could be picked up and thrown by the mower in any direction and cause serious personal injury to the operator or any others allowed in the area. Plan your mowing pattern to avoid discharge of material toward roads, sidewalks, bystanders and the like. To help avoid a thrown objects injury, keep children, bystanders and helpers at least 75 feet from the mower while it is in operation.
- Do not put hands or feet near or under rotating parts. Keep clear of discharge opening at all times as the rotating blade can cause injury.
- Many injuries occur as a result of the mower being pulled over the foot during a fall. Do not hang on to the mower if you are falling; release the handle immediately.
- Never pull the mower toward you while you are walking. If you must back the mower away from a wall or obstruction first look down and behind, and then follow these steps:
 - a. Step back from the mower to fully extend your arms.
 - b. Be sure you are well balanced with sure footing.
 - c. Pull the mower back slowly, no more than half way toward you.
 - d. Repeat these steps as needed.
- Do not operate the mower while under the influence of alcohol or drugs.
- Do not engage the self-propelled mechanism on units so equipped while starting engine.

- The blade control handle is a safety device. Never attempt to bypass its operation. Doing so makes the safety device inoperative and may result in personal injury through contact with the rotating blade. The blade control handle must operate easily in both directions and automatically return to the disengaged position when released.
- Never operate the mower in wet grass. Always be sure of your footing. A slip and fall can cause serious personal injury.
- Keep a firm hold on the handle and walk, never run. If you feel you are losing your footing, **RELEASE THE BLADE CONTROL HANDLE IMMEDIATELY** and the blade will stop rotating within three seconds.
- Mow only in daylight or good artificial light.
- Stop the blade when crossing gravel drives, walks or roads.
- If the equipment should start to vibrate abnormally, stop the engine and check immediately for the cause. Vibration is generally a warning of trouble.
- Shut the engine off and wait until the blade comes to a complete stop before removing the grass catcher or unclogging the chute. The cutting blade continues to rotate for a few seconds after the engine is shut off. Never place any part of the body in the blade area until you are sure the blade has stopped rotating.
- Never operate mower without proper guards, grass catcher, plates or other safety protective devices in place.
- Muffler and engine become hot and can cause a burn. Do not touch.
- Only use accessories approved for this machine by the manufacturer.
- Read, understand, and follow all instructions provided with the approved accessory.
- If situations occur which are not covered in this manual, use care and good judgment. Contact your dealer for assistance. Telephone 1-800-800-7310 for the name of your nearest dealer.

Slope Operation

- For your safety, use the slope gauge included as part of this manual to measure slopes before operating this unit on a sloped or hilly area. If the slope is greater than 15 degrees as shown on the slope gauge, do not operate this unit on that area or serious injury could result.

Do:

- Mow across the face of slopes; never up and down. Exercise extreme caution when changing direction on slopes.
- Watch for holes, ruts, hidden objects, or bumps. Tall grass can hide obstacles.

- Always be sure of your footing. A slip and fall can cause serious personal injury. If you feel you are losing your balance release the blade control handle immediately and the blade will stop in less than 3 seconds.

Do not:

- Do not mow near drop-offs, ditches or embankments. The operator could lose footing or balance.
- Do not mow slopes greater than 15 degrees as shown on the slope gauge.
- Do not mow on wet grass. Reduced footing could cause slipping.

Children

- Tragic accidents can occur if the operator is not alert to the presence of children. Children are often attracted to the mower and the mowing activity. Never assume that children will remain where you last saw them.
- Keep children out of the mowing area and under the watchful care of a responsible adult other than the operator.
- Be alert and turn mower off if a child enters the area.
- Before and while moving backwards, look behind and down for small children or other objects.
- Never allow children under age 14 to operate the mower. Children 14 years of age and above should read and understand the operation instructions and safety rules in this manual.
- Use extreme care when approaching blind corners, shrubs, trees, or other objects that may obscure your vision of a child or hazard.

Service

- Use extreme care in handling gasoline and other fuels. They are extremely flammable and the vapors are explosive.
- Use only an approved gasoline container.
- Never remove gas cap or add fuel while the engine is running. Allow engine to cool at least two minutes before refueling.
- Replace gasoline cap securely and wipe off any spilled gasoline before starting the engine as it may cause a fire or explosion.
- Extinguish all cigarettes, cigars, pipes and other sources of ignition.
- Never refuel machine indoors because flammable vapors will accumulate in the area.
- Never store the machine or fuel container inside where there is an open flame or spark such as a gas water heater, space heater, or furnace.
- Never run an engine inside a closed area.

- To reduce fire hazard, keep mower free of grass, leaves, or other debris build-up. Clean up oil or fuel spillage. Allow mower to cool at least 5 minutes before storing.
- Before cleaning, repairing, or inspecting, make certain the blade and all moving parts have stopped. Disconnect the spark plug wire, and keep the wire away from the spark plug to prevent accidental starting.
- Check the blade and engine mounting bolts at frequent intervals for proper tightness. Also, visually inspect blade for damage (e.g., bent, cracked or worn). Replace with blade which meets original equipment specifications listed in this manual.
- Keep all nuts, bolts, and screws tight to be sure the equipment is in safe working condition.
- Never tamper with safety devices. Check their proper operation regularly.
- After striking a foreign object, stop the engine, remove the wire from the spark plug, and thoroughly inspect the mower for any damage. Repair the damage before starting and operating the mower.
- Never attempt to make a wheel or cutting height adjustment while the engine is running.
- Grass catcher components are subject to wear, damage and deterioration, which could expose moving parts or allow objects to be thrown. For safety protection, frequently check components and replace with manufacturer's recommended parts, when necessary.
- Mower blades are sharp and can cut. Wrap the blade(s) or wear gloves, and use extra caution when servicing them.
- Do not change the engine governor setting or overspeed the engine. Excessive engine speeds are dangerous.

Your Responsibility

- Restrict the use of this power machine to persons who read, understand and follow the warnings and instructions in this manual and on the machine.



SECTION 2: SLOPE GAUGE

Use this page as a guide to determine slopes where you may not operate the lawn mower safely.

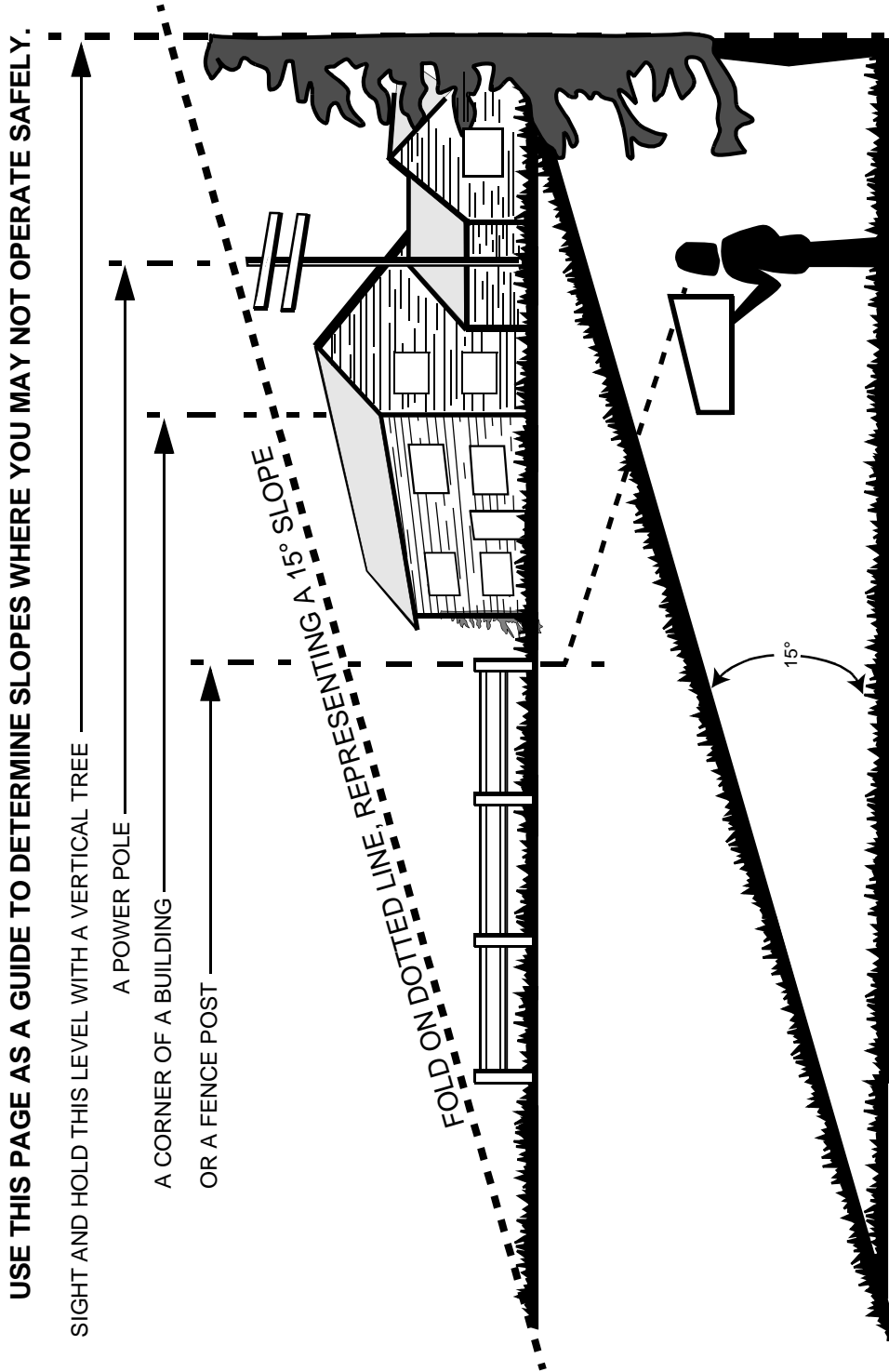

WARNING

Do not mow on inclines with a slope in excess of 15 degrees (a rise of approximately 2-1/2 feet every 10 feet). A riding mower could overturn and cause serious injury. If operating a walk-behind mower on such a slope, it is extremely difficult to maintain your footing and you could slip, resulting in serious injury. Operate RIDING mowers up and down slopes, never across the face of slopes. Operate WALK-BEHIND mowers across the face of slopes, never up and down slopes.

SECTION 3: UNPACKING

Removing Unit From Carton

- Remove staples, break glue on top flaps, or cut tape at carton end and peel along top flap to open carton.

- Remove loose parts if included with unit (i.e., operators manual, bottle of oil, etc.).
- Cut corners and lay carton down flat.
- Remove packing material.
- Roll or slide unit out of carton. Check carton thoroughly for loose parts.

SECTION 4: ASSEMBLING YOUR LAWN MOWER

IMPORTANT: This unit is shipped WITHOUT GASOLINE or OIL. Be certain to service engine with gasoline and oil as instructed in the separate engine manual before operating your mower.

NOTE: Reference to right or left hand side of the mower is observed from the operating position.

Tools Required

Pair of pliers (not necessary, but helpful)

Assembling Mower

- Remove any packing material which may be between the upper and lower handles for shipping purposes.
- Disconnect spark plug wire from the spark plug and ground it against the engine.
- Pull up and back on the upper handle to raise the handle into the operating position. Make certain the lower handle is seated securely into the handle mounting brackets. Tighten the hand knobs on each side of the handle (carriage bolts must be seated properly on the handle). See Figure 1.

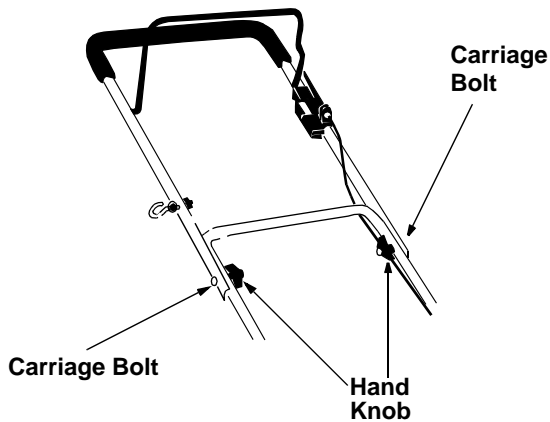

Figure 1

NOTE: Your mower is shipped with the handle in the higher height position. If you wish to lower the height of the handle, refer to the Handle Height Adjustment Section on page 10.

- Remove the hairpin clips from the outer holes in the weld pins on the handle mounting brackets.
- Using a pair of pliers, squeeze one leg of the lower handle against the handle mounting bracket. Insert the hairpin clip into the inner hole on the weld pin. See Figure 2. Repeat on other side.

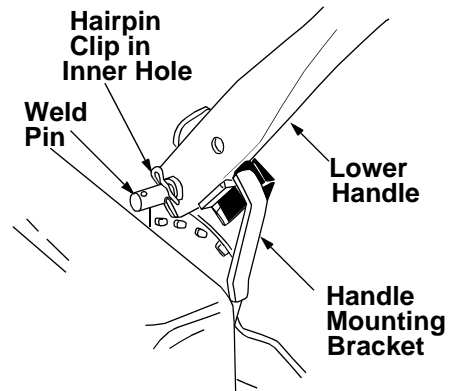

Figure 2

- Insert post on cable ties into holes provided on the lower handle. Pull the cable tie tight and trim the excess. See Figure 3.

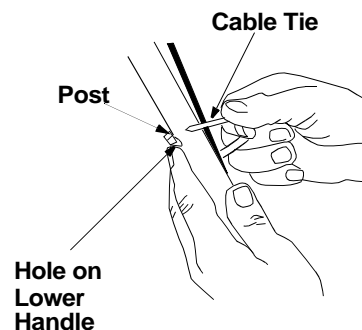

Figure 3

- The rope guide is attached to the right side of the upper handle. Loosen the wing nut which secures the rope guide. For location of the wing nut, see Figure 4.

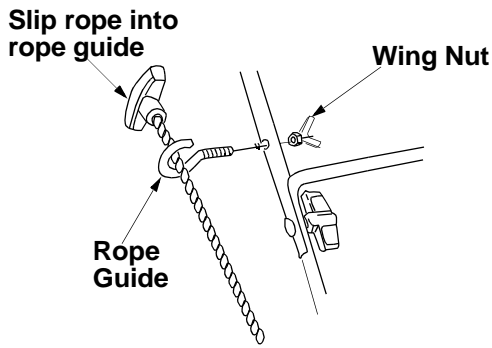

Figure 4

- With the spark plug wire disconnected and grounded, hold the blade control handle against the upper handle, and pull the starter rope out of the engine. Release the blade control handle. Slip the starter rope into the rope guide. Tighten the wing nut. See Figure 4.

- Make certain all nuts and bolts are tightened securely.
- Your mower has been shipped as a mulcher. To convert it to a side-discharge mower, lift the mulching plug. Slide the two hooks on the side-discharge deflector under the hinge pin on the mulching plug assembly. Lower the mulching plug. See Figure 5 .

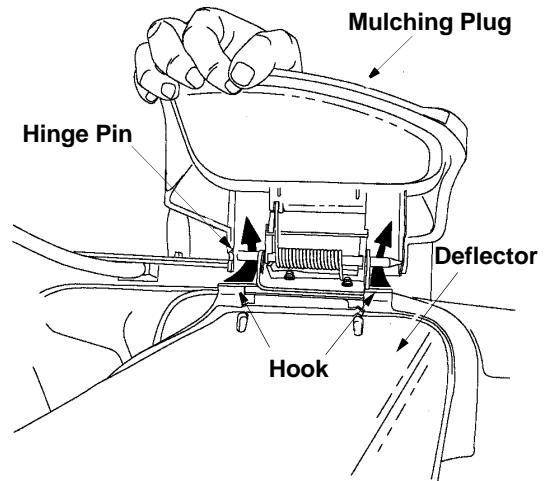

Figure 5

SECTION 5: KNOW YOUR LAWN MOWER

Blade Control Handle



WARNING: This control mechanism is a safety device. Never attempt to bypass its operations. The blade will be rotating whenever the engine is running.

The blade control handle is located on the upper handle of the mower. See Figure 6. The blade control handle must be depressed in order to operate the unit. Release the blade control handle to stop the engine and blade.

Throttle Control

The throttle control lever is located on the left upper handle and is used to regulate engine speed. Moving the throttle lever all the way forward activates the choke. The choke is used to close the choke plate on the carburetor and assist in starting a cold engine. It may not be necessary to use it when restarting a warm engine after a short shutdown. See Figure 6.

Recoil Starter

- The recoil starter handle is attached to the handle. See Figure 6. Stand behind the unit in the operating position to start the unit.

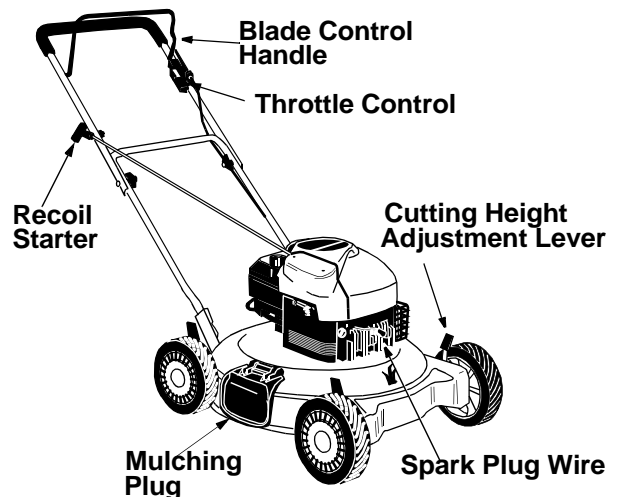

Figure 6

SECTION 6: OPERATING YOUR LAWN MOWER

Keep hands and feet away from the chute area on the cutting deck. See safety labels on page 5.

The operation of any lawn mower can result in foreign objects being thrown into the eyes, which can result in severe eye damage. Always wear safety glasses or eye shields.

NOTE: For best results raise the cutting position until it is determined which height is best for your lawn. See *Cutting Height Adjustment* section.

Gas And Oil Fill-Up

Service the engine with gasoline and oil as instructed in the separate engine manual. Read instructions carefully.



WARNING: Never fill fuel tank indoors, with engine running or until the engine has been allowed to cool for at least two minutes after running.

Before Starting

- Attach spark plug wire to spark plug. If equipped with a rubber boot, make certain the metal loop on the end of the spark plug wire (inside the rubber boot) is fastened securely over the metal tip on the spark plug.

To Start Engine And Engage Blade

- Make sure that the fuel valve lever found on the left side of the engine is in the ON position. See Figure 7.

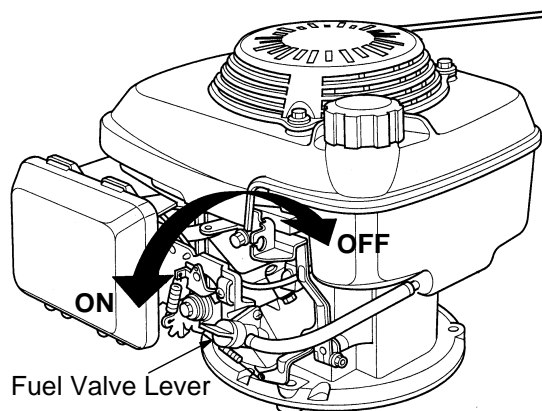

Figure 7

- Move the throttle control/choke lever all the way forward into the choke position. A warm engine may not require choking. If the engine is already warm as a result of recent operation, just move the throttle into the rabbit position and allow it to remain there.
- Standing behind the unit, depress the blade control handle and hold it against the upper handle.

- Grasp starter handle and pull rope out slowly until engine reaches start of compression cycle (rope will pull slightly harder at this point). Let the rope rewind slowly.
- Pull rope with a rapid, continuous, full arm stroke. Keep a firm grip on starter handle. Return it slowly to the rope guide.

NOTE: If any problems are encountered, refer to the *Trouble Shooting Guide* for helpful information.

To Stop Engine And Blade

- Release the blade control handle to stop the engine and blade.



WARNING: The blade continues to rotate for a few seconds after the engine is shut off.

- Disconnect the spark plug wire and ground it against the engine to prevent accidental starting while equipment is unattended.

Using Your Rotary Mower

- Be sure that lawn is clear of stones, sticks, wire, or other objects which could damage lawn mower or engine. Such objects could be accidentally thrown by the mower in any direction and cause serious personal injury to the operator and others.
- For best results, do not cut wet grass because it tends to stick to the underside of the mower, preventing proper discharge of grass clippings, and could cause you to slip and fall. New grass, thick grass or wet grass may require a narrower cut.
- When using side-discharge mower, the best mowing pattern is one that allows the clippings to discharge towards the uncut part of the lawn. This permits recutting of the clippings to further pulverize them. When cutting high weeds, discharge towards cut portion, then recut at right angles to first direction.
- For a healthier lawn, always cut off one-third or less of the total length of the grass. Lawn should be cut in the fall as long as there is growth.
- This mower is designed to be operated at full throttle to give you the best cut and do the most effective job of mowing.



WARNING: If you strike a foreign object, stop the engine. Remove wire from spark plug, thoroughly inspect the mower for any damage, and repair the damage before restarting and operating the mower. Extensive vibration of the mower during operation is an indication of damage. The unit should be promptly inspected and repaired.

SECTION 7: MAKING ADJUSTMENTS



WARNING: Do not at any time make any adjustment to lawn mower without first stopping engine and disconnecting spark plug wire.

Cutting Height Adjustment

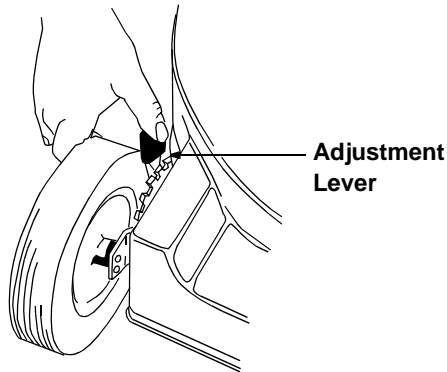

Figure 8

There is an adjusting plate and thumb lever at each wheel position to adjust the cutting height. Each adjusting plate has nine height positions. Height of cut will change if you move the thumb lever from one hole to another. Simply depress the lever towards wheel and move the wheel and lever assembly to the desired position. All wheels must be placed in the same relative position for uniform cutting height. See Figure 8.

For rough or uneven lawns, move the height adjustment handles to positions which will give a higher cutting height. Both front and rear handles must be placed in the same relative position.

Handle Height Adjustment

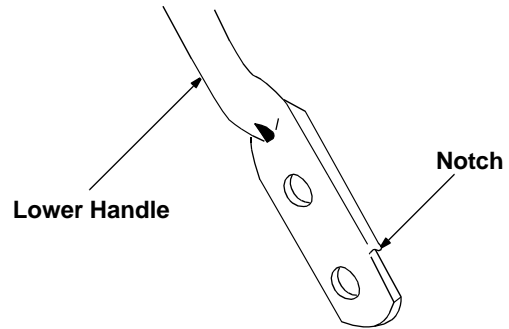

Figure 9

Your mower is shipped with the handle in the higher height position. To lower the handle height, proceed as follows.

- Remove the starter rope from the rope guide.
- Remove the upper handle by removing the hand knobs and carriage bolts. Lay the upper handle out of the way, being careful not to bend or kink the cable.
- Remove the hairpin clips from the weld pins on the handle brackets. Press inward on the legs of the lower handle. Remove lower handle from the mower.
- Turn the lower handle around so the notch on the bottom of the lower handle is facing forward as shown in Figure 9. Reassemble, placing the bottom holes in the handle over the weld pins in the handle mounting bracket.
- Reassemble the upper handle.
- Place the hairpin clips in the inner holes in the weld pins and attach the starter rope as instructed in the Set-Up Instructions.

SECTION 8: SERVICE



WARNING: Always stop engine and disconnect spark plug wire before cleaning, lubricating or doing any kind of work on lawn mower.

Blade Control

Lubricate the pivot points on the blade control handle and the brake cable at least once a season with light oil. See Figure 10. The blade control must operate freely in both directions. Also lubricate the pivot points on the mulch baffle and the height adjustment lever.

Wheels

Lubricate the wheel bearings (if so equipped) at least once a season with light oil (or engine oil). Also, if the wheels are removed for any reason, lubricate the surface of the axle bolt and the inner surface of the wheel with light oil.

Engine

Follow engine manual for lubrication instructions.

Lubrication Chart:

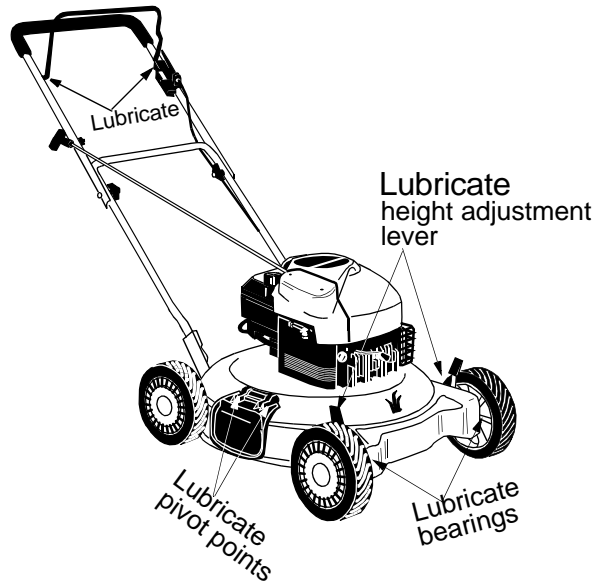

Figure 10

SECTION 9: MAINTAINING YOUR LAWN MOWER



WARNING: Be sure to disconnect and ground the spark plug wire before performing any repairs or maintenance.

NOTE: When tipping the unit, empty the fuel tank and keep engine spark plug side up.

Cutting Blade



WARNING: When removing the cutting blade for sharpening or replacement, protect hands by using heavy gloves or a rag to grasp the cutting blade.

To remove blade

- Remove the bolt and blade bell support which hold the blade and adapter to the engine crankshaft. See Figure 11. Remove the blade and the adapter from the crankshaft.



WARNING: Periodically inspect the blade adapter for cracks, especially if you strike a foreign object. Replace when necessary.

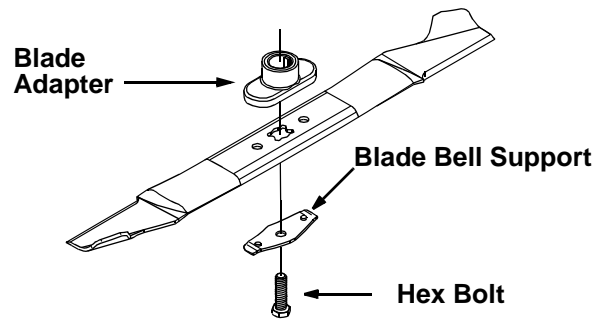

Figure 11

- When sharpening the blade, follow the original angle of grind as a guide. It is extremely important that each cutting edge receives an equal amount of grinding to prevent an unbalanced blade. An unbalanced blade will cause excessive vibration when rotating at high speeds, may cause damage to the mower and could break, causing personal injury.
- The blade can be tested by balancing it on a round shaft screwdriver. Remove metal from the heavy side until it balances evenly. It is recommended that the blade always be removed from the adapter for the best test of balance.

- Before reinstalling the blade and the blade adapter to the unit, lubricate the engine crankshaft and the inner surface of the blade adapter with light oil (or engine oil). Lubricating the bolt holes, bolts and inner surface of the nuts is also recommended.

To Reinstall Blade

- Be sure to install the blade with the side of the blade marked “Bottom” (or with part number) facing the ground when the mower is in the operating position.
- Be certain the blade is aligned with and seated onto the blade adapter flanges.
- Place blade bell support on blade. Make sure the notches on the blade bell support are aligned with the small hole in the blade.
- Replace hex bolt.
- Tighten to torque: 450 in. lbs. min., 600 in. lbs. max.
- To ensure safe operation of mower, check all nuts and bolts periodically for correct torque.

Deck Maintenance

- The underside of the mower deck should be cleaned after each use to prevent a buildup of grass clippings, leaves, dirt or other matter. If this debris is allowed to accumulate, it will invite rust and corrosion, and may prevent proper mulching.
- The deck may be cleaned by tilting the mower and scraping clean with a suitable tool (make certain the spark plug wire is disconnected). Do not use high pressure cleaners or water.

- We do not recommend the use of pressure washers or garden hose to clean your unit. They may cause damage to electric components, spindles, pulleys, bearings or the engine. The use of water will result in shortened life and reduce serviceability.

Engine Maintenance

- Refer to the separate engine manual for all engine maintenance instructions.
- Maintain ENGINE OIL as instructed in the engine manual.
- Service AIR CLEANER every 25 hours under normal conditions. Clean every few hours under extremely dusty conditions. Poor engine performance and flooding usually indicates that the air cleaner should be serviced. To service the air cleaner, refer to the engine manual.
- The SPARK PLUG should be cleaned and the gap reset once a season. Spark plug replacement is recommended at the start of each mowing season; check engine manual for correct plug type and gap specifications.
- CLEAN the engine regularly with a cloth or brush. Keep the cooling system (blower housing area) cleaned to permit proper air circulation which is essential to engine performance and life. Be certain to remove all grass, dirt and combustible debris from muffler area.

SECTION 10: OFF-SEASON STORAGE

The following steps should be taken to prepare lawn mower for storage.

- Clean and lubricate mower thoroughly as described in the lubrication instructions.
- We do not recommend the use of pressure washers or garden hose to clean your unit. They may cause damage to electric components, spindles, pulleys, bearings or the engine. The use of water will result in shortened life and reduce serviceability.

- Refer to engine manual for correct engine storage instructions.
- Coat mower’s cutting blade with chassis grease to prevent rusting.
- Store mower in a dry, clean area. Do not store next to corrosive materials, such as fertilizer.

NOTE: *When storing any type of power equipment in an unventilated or metal storage shed, care should be taken to rust-proof the equipment. Using a light oil or silicone, coat the equipment, especially cables and all moving parts.*

SECTION 11: TROUBLE SHOOTING GUIDE

Trouble	Possible Cause(s)	Corrective Action
Engine fails to start	Blade control handle disengaged. Spark plug wire disconnected. Throttle control lever not in correct starting position. Fuel tank empty, or stale fuel. Blocked fuel line. Faulty spark plug. Engine flooded.	Engage blade control handle. Connect wire to spark plug. Move throttle lever to FAST or choke position. Fill tank with clean, fresh gasoline. Clean fuel line. Clean, adjust gap or replace. Crank engine with throttle in FAST position.
Engine runs erratic	Unit running in CHOKE position. Spark plug wire loose. Blocked fuel line or stale fuel. Vent in gas cap plugged. Water or dirt in fuel system. Dirty air cleaner. Carburetor out of adjustment.	Move throttle lever to FAST position. Connect and tighten spark plug wire. Clean fuel line; fill tank with clean, fresh gasoline. Clear vent. Drain fuel tank. Refill with fresh fuel. Clean air cleaner. Adjust carburetor.
Engine overheats	Engine oil level low. Air flow restricted. Carburetor not adjusted properly.	Fill crankcase with proper oil. Remove blower housing and clean. Adjust carburetor.
Occasional skip (hesitates) at high speed	Spark plug gap too close.	Adjust gap to .030".
Idles poorly	Spark plug fouled, faulty or gap too wide. Carburetor improperly adjusted. Dirty air cleaner.	Reset gap to .030" or replace spark plug. Adjust carburetor. Clean air cleaner.
Excessive vibration	Cutting blade loose or unbalanced. Bent cutting blade.	Tighten blade and adapter. Balance blade. Replace blade.
Mower will not mulch grass	Engine speed too low. Wet grass. Excessively high grass. Dull blade.	Set throttle to full throttle. Do not mow when grass is wet; wait until later to cut. Mow once at a high cutting height, then mow again at desired height or make a narrower cutting swath (1/2 width). Sharpen or replace blade.
Uneven cut	Wheels not positioned correctly. Dull blade.	Place all four wheels in same height position. Sharpen or replace blade.

Refer to separate engine manual packed with your mower for more engine related information.

NOTE: For repairs beyond the minor adjustments listed above, contact your nearest authorized service dealer.

SECTION 12: PARTS LIST FOR MODEL 108Q

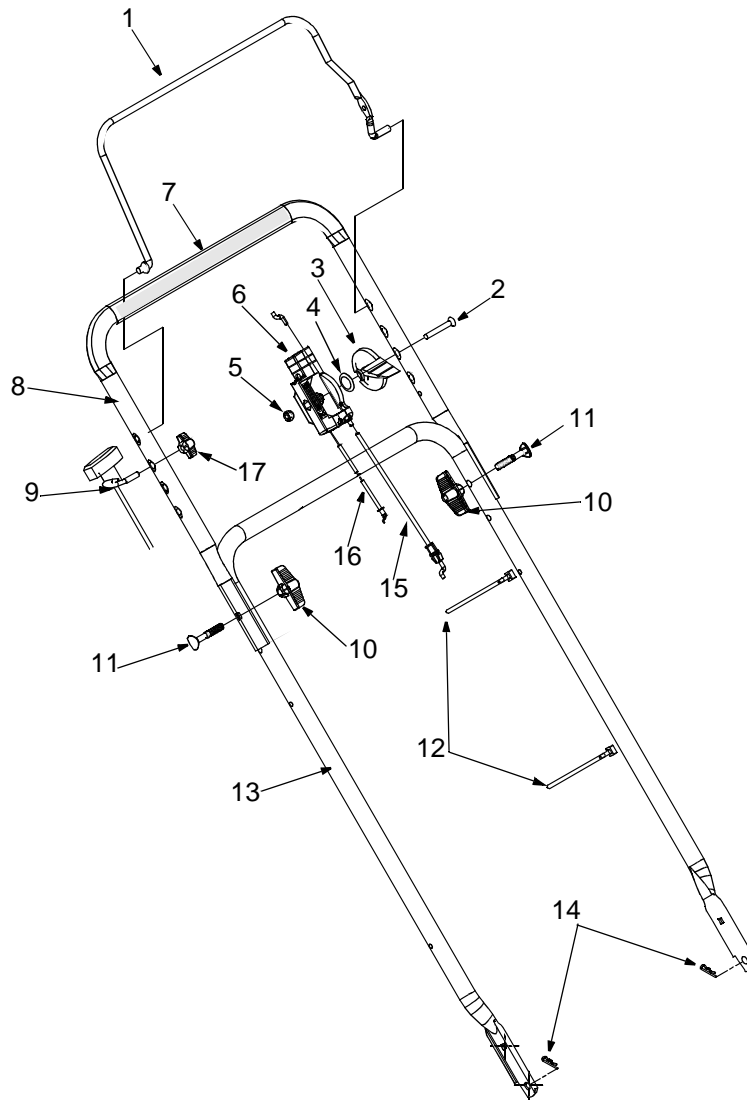

Ref. No.	Part No.	Description	Ref. No.	Part No.	Description
1	747-0824	Control Handle Ass'y.	10	720-0314	Hand Knob
2	710-0605	Oval C-Sunk Screw	11	710-1174	Carriage Bolt
3	746-0876	Throttle Lever	12	726-0240	Cable Tie
4	736-0501	Curved Spring Washer	13	749-0928-0637	Lower Handle
5	712-0324	Hex Lock Nut	14	714-0104	Hairpin Clip
6	746-0875	Throttle Housing w/ERS	15	746-0550	Control Cable 39" Lg.
7	720-0295	Foam Grip	16	746-1110	Throttle Cable 42" Lg.
8	749-0705	Upper Handle	17	720-0279	Handle Knob
9	710-1205	Rope Guide	-	737-0343	Bottle of Oil (not shown)

Model 108Q

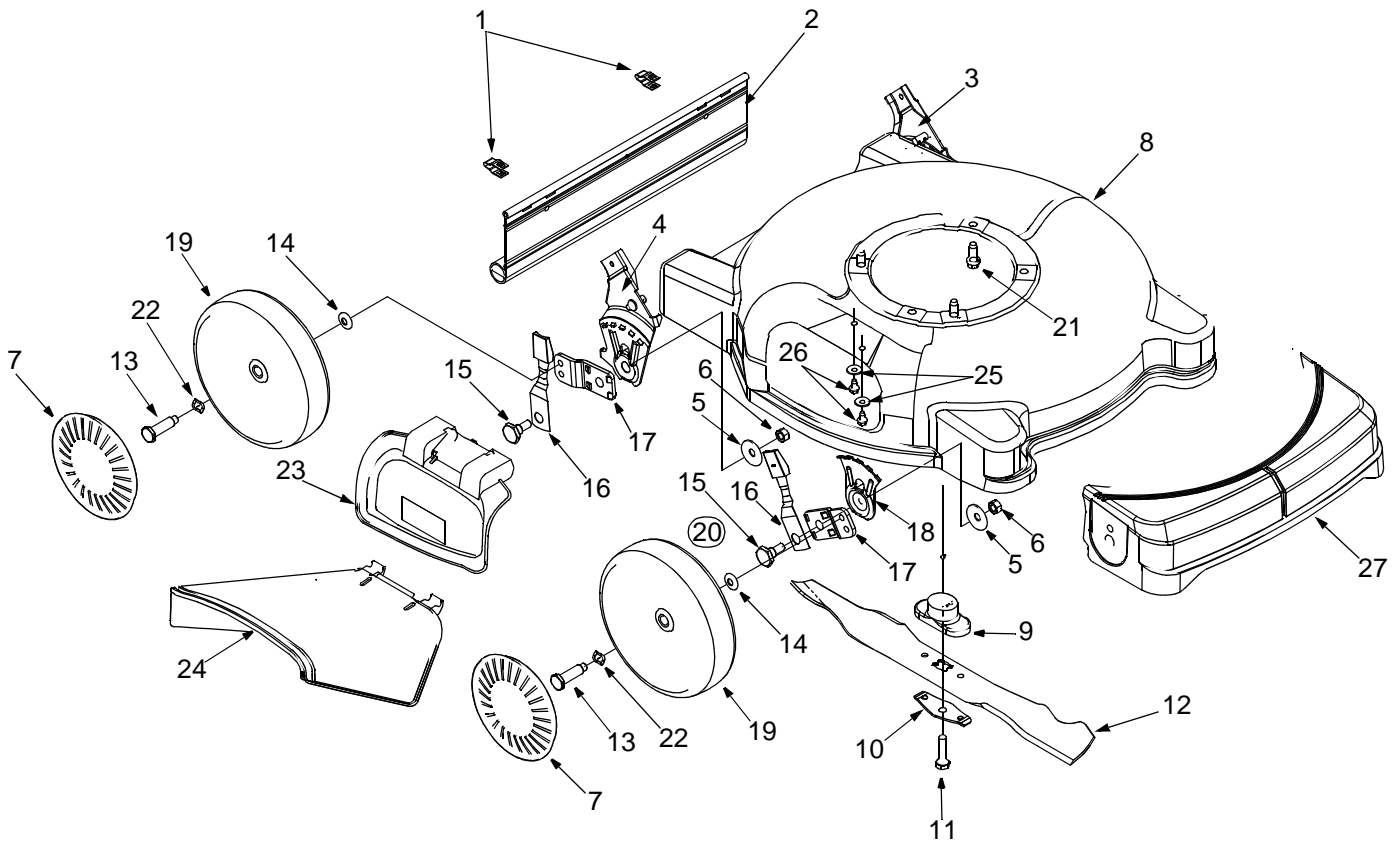

Ref. No.	Part No.	Description	Ref. No.	Part No.	Description
1	17098	Hinge Clip	17	15262B	Pivot Bar
2	731-0872A	Rear Flap	18	15261A	Height Adj. Plate
3	682-3025	Handle Bracket Ass'y LH	19	734-1978	Wheel Assembly
4	682-3024	Handle Bracket Ass'y RH	20	14578	Height Adj. Ass'y. Comp. R.F.
5	736-0356	Bell Washer .39" ID x 1.38"		14579	Height Adj. Ass'y. Comp. L.F.
6	712-0798	Hex Nut 3/8-16 Thd.	21	710-0654A	Hex Lock Wash. Hd. Screw 3/8-16 x 1.0" Lg.
7	731-1426	Hub Cap: Yellow	22	736-0504	Wave Washer
8	682-0139	Deck Assembly	23	682-7002	Mulching Plug
9	753-0588	Blade Adapter Kit	24	731-1409	Chute Deflector
10	736-0524A	Blade Bell Support	25	736-0270	Bell Washer
11	710-1044	Hex Bolt 7/16-20 x 1.5"	26	710-0599	Hex Wash. Hd. TT Screw 1/4-20 x .5" Lg.
12	742-0740	20" Mulch Blade	27	731-1933	Cover: Front End
13	738-0102	Axle Bolt			
14	736-0105	Bell Washer .400" ID x .88"			
15	738-0507B	Shoulder Bolt			
16	14832	Spring Lever Ass'y w/Knob			

MANUFACTURER'S LIMITED WARRANTY FOR:



The limited warranty set forth below is given by MTD PRODUCTS INC ("MTD") with respect to new merchandise purchased and used in the United States, its possessions and territories.

MTD warrants this product against defects in material and workmanship for a period of two (2) years commencing on the date of original purchase and will, at its option, repair or replace, free of charge, any part found to be defective in material or workmanship. This limited warranty shall only apply if this product has been operated and maintained in accordance with the Operator's Manual furnished with the product, and has not been subject to misuse, abuse, commercial use, neglect, accident, improper maintenance, alteration, vandalism, theft, fire, water or damage because of other peril or natural disaster. Damage resulting from the installation or use of any accessory or attachment not approved by MTD Products Inc. for use with the product(s) covered by this manual will void your warranty as to any resulting damages.

Normal wear parts or components thereof are subject to separate terms as follows: All normal wear part or component failures will be covered on the product for a period of 90 days regardless of cause. After 90 days, but within the two year period, normal wear part failures will be covered ONLY IF caused by defects in material or workmanship of OTHER component parts. Normal wear parts and components include, but are not limited to, belts, blades, blade adapters, grass bags, rider deck wheels, seats, snow thrower skid shoes, shave plates and tires. Batteries are covered by a 90-day limited replacement warranty.

HOW TO OBTAIN SERVICE: Warranty service is available, WITH PROOF OF PURCHASE THROUGH YOUR LOCAL AUTHORIZED SERVICE DEALER. To locate the dealer in your area, please check for a listing in the Yellow Pages or contact the Customer Service Department of MTD PRODUCTS INC by calling 1-800-800-7310 or writing to P.O. Box 368022, Cleveland, Ohio 44136-9722.

This limited warranty does not provide coverage in the following cases:

- a. The engine or component parts thereof. These items carry a separate manufacturer's warranty. Please refer to the applicable manufacturer's warranty on these items.
- b. Log splitter pumps, valves and cylinders have a separate one year warranty.

c. Routine maintenance items such as lubricants, filters, blade sharpening and tune-ups, or adjustments such as brake adjustments, clutch adjustments or deck adjustments; and normal deterioration of the exterior finish due to use or exposure.

d. MTD does not extend any warranty for products sold or exported outside of the United States of America, its possessions and territories, except those sold through MTD's authorized channels of export distribution.

No implied warranty, including any implied warranty of merchantability or fitness for a particular purpose, applies after the applicable period of express written warranty above as to the parts as identified. No other express warranty or guaranty, whether written or oral, except as mentioned above, given by any person or entity, including a dealer or retailer, with respect to any product shall bind MTD. During the period of the Warranty, the exclusive remedy is repair or replacement of the product as set forth above. (Some states do not allow limitations on how long an implied warranty lasts, so the above limitation may not apply to you.)

The provisions as set forth in this Warranty provide the sole and exclusive remedy arising from the sales. MTD shall not be liable for incidental or consequential loss or damages including, without limitation, expenses incurred for substitute or replacement lawn care services, for transportation or for related expenses, or for rental expenses to temporarily replace a warranted product. (Some states do not allow the exclusion or limitation of incidental or consequential damages, so the above exclusion or limitation may not apply to you.)

In no event shall recovery of any kind be greater than the amount of the purchase price of the product sold. Alteration of the safety features of the product shall void this Warranty. You assume the risk and liability for loss, damage, or injury to you and your property and/or to others and their property arising out of the use or misuse or inability to use the product.

This limited warranty shall not extend to anyone other than the original purchaser, original lessee or the person for whom it was purchased as a gift.

How State Law Relates to this Warranty: This limited warranty gives you specific legal rights, and you may also have other rights which vary from state to state.