



OPERATOR'S MANUAL



20" Mulching
Self Starter
Push Mower
Model
109T

IMPORTANT: READ SAFETY RULES AND INSTRUCTIONS CAREFULLY

Warning: This unit is equipped with an internal combustion engine and should not be used on or near any unimproved forest-covered, brush-covered or grass-covered land unless the engine's exhaust system is equipped with a spark arrester meeting applicable local or state laws (if any). If a spark arrester is used, it should be maintained in effective working order by the operator. In the State of California the above is required by law (Section 4442 of the California Public Resources Code). Other states may have similar laws. Federal laws apply on federal lands. A spark arrester for the muffler is available through your nearest engine authorized service dealer or contact the service department, P.O. Box 368022 Cleveland, Ohio 44136-9722.

MTD PRODUCTS INC. P.O. BOX 368022 CLEVELAND, OHIO 44136-9722

PRINTED IN U.S.A.
ECO No.

FORM NO. 770-10453
(1/01)

TABLE OF CONTENTS

| Content | Page |
|---|------|
| Important Safe Operation Practices..... | 3 |
| Slope Gauge..... | 6 |
| Unpacking..... | 7 |
| Assembling Your Lawn Mower..... | 7 |
| Know Your Lawn Mower | 8 |
| Operating Your Lawn Mower | 9 |
| Making Adjustments | 11 |
| Service..... | 12 |
| Maintaining Your Lawn Mower..... | 12 |
| Off-Season Storage | 14 |
| Troubleshooting..... | 15 |
| Parts List..... | 16 |

FINDING MODEL NUMBER

This Operator's Manual is an important part of your new Lawn Mower. It will help you assemble, prepare and maintain the unit for best performance. Please read and understand what it says.



Before you start assembling your new equipment, please locate the model plate on the equipment and copy the information from it in the space provided below. The information on the model plate is very important if you need help from our Customer Support Department or an authorized dealer.

- You can locate the model number by standing behind the unit in the operating position and looking at the rear of the deck. A sample model plate is explained below. For future reference, please copy the model number and the serial number of the equipment in the space below.

| | |
|----------------|-----------------|
| _____ | _____ |
| (Model Number) | (Serial Number) |



MTD PRODUCTS INC
CLEVELAND, OHIO 44136

Copy the model number here: _____

Copy the serial number here: _____

CALLING CUSTOMER SUPPORT

If you have difficulty assembling this product or have any questions regarding the controls, operation or maintenance of this unit, please call the Customer Support Department.



Call **1- (330) 220-4MTD (4683)** or **1- (800)-800-7310** to reach a Customer Support representative. Please have your unit's model number and serial number ready when you call. See previous section to locate this information. You will be asked to enter the serial number in order to process your call.

For more details about proper lawn care, visit our website at www.mtdproducts.com

SECTION 1: IMPORTANT SAFE OPERATION PRACTICES



WARNING: This symbol points out important safety instructions which, if not followed, could endanger the personal safety and/or property of yourself and others. Read and follow all instructions in this manual before attempting to operate this machine. Failure to comply with these instructions may result in personal injury. When you see this symbol—HEED ITS WARNING.



WARNING: The Engine Exhaust from this product contains chemicals known to the State of California to cause cancer, birth defects or other reproductive harm.



DANGER: This machine was built to be operated according to the rules for safe operation in this manual. As with any type of power equipment, carelessness or error on the part of the operator can result in serious injury. This machine is capable of amputating hands and feet and throwing objects. Failure to observe the following safety instructions could result in serious injury or death.

General Operation

1. Read this operator's manual carefully in its entirety before attempting to assemble this machine. Read, understand, and follow all instructions on the machine and in the manual(s) before operation. Be completely familiar with the controls and the proper use of this machine before operating it. Keep this manual in a safe place for future and regular reference and for ordering replacement parts.
2. This machine is a precision piece of power equipment, not a plaything. Therefore, exercise extreme caution at all times. Your unit has been designed to perform one job: to mow grass. Do not use it for any other purpose.
3. Never allow children under 14 years old to operate this machine. Children 14 years old and over should read and understand the operation instructions and safety rules in this manual and should be trained and supervised by a parent. Only responsible individuals who are familiar with these rules of safe operation should be allowed to use this machine.
4. Thoroughly inspect the area where the equipment is to be used. Remove all stones, sticks, wire, bones, toys and other foreign objects which could be tripped over or picked up and thrown by the blade. Thrown objects can cause serious personal injury. Plan your mowing pattern to avoid discharge of material toward roads, sidewalks, bystanders and the like. Also, avoid discharging material against a wall or obstruction which may cause discharged material to ricochet back toward the operator.
5. To help avoid blade contact or a thrown object injury, stay in the operator zone behind the handles and keep children, bystanders, helpers and pets at least 75 feet from the mower while it is in operation. Stop machine if anyone enters the area.
6. Always wear safety glasses or safety goggles during operation and while performing an adjustment or repair to protect your eyes. Thrown objects which ricochet can cause serious injury to the eyes.
7. Wear sturdy, rough-soled work shoes and close-fitting slacks and shirts. Shirts and pants that cover the arms and legs and steel-toed shoes are recommended. Never operate this machine in bare feet, sandals, slippery or light weight (e.g. canvas) shoes.
8. Do not put hands or feet near rotating parts or under the cutting deck. Contact with the blade can amputate hands and feet.
9. A missing or damaged discharge cover can cause blade contact or thrown object injuries.
10. Many injuries occur as a result of the mower being pulled over the foot during a fall caused by slipping or tripping. Do not hold on to the mower if you are falling; release the handle immediately.
11. Never pull the mower back toward you while you are walking. If you must back the mower away from a wall or obstruction first look down and behind to avoid tripping and then follow these steps:
 - a. Step back from the mower to fully extend your arms.
 - b. Be sure you are well balanced with sure footing.
 - c. Pull the mower back slowly, no more than half way toward you.
 - d. Repeat these steps as needed.
12. Do not operate the mower while under the influence of alcohol or drugs.
13. Do not engage the self-propelled mechanism on units so equipped while starting engine.
14. The blade control handle is a safety device. Never attempt to bypass its operation. Doing so makes the safety device inoperative and may result in personal injury through contact with the rotating blade. The blade control handle must operate easily in both directions and automatically return to the disengaged position when released.
15. Never operate the mower in wet grass. Always be sure of your footing. A slip and fall can cause serious personal injury. If you feel you are losing your footing, release the blade control handle immediately and the blade will stop rotating within three seconds.
16. Mow only in daylight or in good artificial light. Walk, never run.
17. Stop the blade when crossing gravel drives, walks or roads.
18. If the equipment should start to vibrate abnormally, stop the engine and check immediately for the cause. Vibration is generally a warning of trouble.
19. Shut the engine off and wait until the blade comes to a complete stop before removing the grass catcher or unclogging the chute. The cutting blade continues to rotate for a few seconds after the engine is shut off. Never place any part of the body in the blade area until you are sure the blade has stopped rotating.

20. Never operate mower without proper trail shield, discharge cover, grass catcher, blade control handle or other safety protective devices in place and working. Never operate mower with damaged safety devices. Failure to do so, can result in personal injury.
21. Muffler and engine become hot and can cause a burn. Do not touch.
22. Only use parts and accessories made for this machine by the manufacturer. Failure to do so, can result in personal injury.
23. If situations occur which are not covered in this manual, use care and good judgment. Contact your dealer for assistance. Telephone 1-800-800-7310 for the name of your nearest dealer.

Slope Operation

Slopes are a major factor related to slip and fall accidents which can result in severe injury. Operation on slopes requires extra caution. If you feel uneasy on a slope, do not mow it. For your safety, use the slope gauge included as part of this manual to measure slopes before operating this unit on a sloped or hilly area. If the slope is greater than 15 degrees, do not mow it.

Do:

1. Mow across the face of slopes; never up and down. Exercise extreme caution when changing direction on slopes.
2. Watch for holes, ruts, rocks, hidden objects, or bumps which can cause you to slip or trip. Tall grass can hide obstacles.
3. Always be sure of your footing. A slip and fall can cause serious personal injury. If you feel you are losing your balance, release the blade control handle immediately, and the blade will stop rotating within 3 seconds.

Do Not:

1. Do not mow near drop-offs, ditches or embankments, you could lose your footing or balance.
2. Do not mow slopes greater than 15 degrees as shown on the slope gauge.
3. Do not mow on wet grass. Unstable footing could cause slipping.

Children

Tragic accidents can occur if the operator is not alert to the presence of children. Children are often attracted to the mower and the mowing activity. They do not understand the dangers. Never assume that children will remain where you last saw them.

1. Keep children out of the mowing area and under the watchful care of a responsible adult other than the operator.
2. Be alert and turn mower off if a child enters the area.
3. Before and while moving backwards, look behind and down for small children.
4. Use extreme care when approaching blind corners, doorways, shrubs, trees, or other objects that may obscure your vision of a child who may run into the mower.
5. Keep children away from hot or running engines. They can suffer burns from a hot muffler.

6. Never allow children under 14 years old to operate a power mower. Children 14 years old and over should read and understand the operation instructions and safety rules in this manual and should be trained and supervised by a parent.

Service

Safe Handling Of Gasoline:

1. To avoid personal injury or property damage use extreme care in handling gasoline. Gasoline is extremely flammable and the vapors are explosive. Serious personal injury can occur when gasoline is spilled on yourself or your clothes which can ignite.
2. Wash your skin and change clothes immediately.
3. Use only an approved gasoline container.
4. Never fill containers inside a vehicle or on a truck or trailer bed with a plastic liner. Always place containers on the ground away from your vehicle before filling.
5. When practical, remove gas-powered equipment from the truck or trailer and refuel it on the ground. If this is not possible, then refuel such equipment on a trailer with a portable container, rather than from a gasoline dispenser nozzle.
6. Keep the nozzle in contact with the rim of the fuel tank or container opening at all times until fueling is complete. Do not use a nozzle lock-open device.
7. Extinguish all cigarettes, cigars, pipes and other sources of ignition.
8. Never fuel machine indoors because flammable vapors will accumulate in the area.
9. Never remove gas cap or add fuel while the engine is hot or running. Allow engine to cool at least two minutes before refueling.
10. Never over fill fuel tank. Fill tank to no more than ½ inch below bottom of filler neck to provide space for fuel expansion.
11. Replace gasoline cap and tighten securely.
12. If gasoline is spilled, wipe it off the engine and equipment. Move unit to another area. Wait 5 minutes before starting the engine.
13. Never store the machine or fuel container inside where there is an open flame, spark or pilot light as on a water heater, space heater, furnace, clothes dryer or other gas appliances.
14. To reduce fire hazard, keep mower free of grass, leaves, or other debris build-up. Clean up oil or fuel spillage and remove any fuel soaked debris.
15. Allow a mower to cool at least 5 minutes before storing.

General Service:

1. Never run an engine indoors or in a poorly ventilated area. Engine exhaust contains carbon monoxide, an odorless and deadly gas.
2. Before cleaning, repairing, or inspecting, make certain the blade and all moving parts have stopped. Disconnect the spark plug wire and ground against the engine to prevent unintended starting.
3. Check the blade and engine mounting bolts at frequent intervals for proper tightness. Also, visually inspect blade for damage (e.g., bent, cracked, worn) Replace blade with the original equipment manufacture's (O.E.M.) blade only, listed in this manual. "Use of parts which do not

meet the original equipment specifications may lead to improper performance and compromise safety!"

4. Mower blades are sharp and can cut. Wrap the blade or wear gloves, and use extra caution when servicing them.
5. Keep all nuts, bolts, and screws tight to be sure the equipment is in safe working condition.
6. Never tamper with safety devices. Check their proper operation regularly.
7. After striking a foreign object, stop the engine, disconnect the spark plug wire and de-energize the starter. (See section "To De-energize Self Starter"). Thoroughly inspect the mower for any damage. Repair the damage before starting and operating the mower.
8. Never attempt to make a wheel or cutting height adjustment while the engine is running.
9. Grass catcher components, discharge cover, and trail shield are subject to wear and damage which could expose moving parts or allow objects to be thrown. For

safety protection, frequently check components and replace immediately with original equipment manufacturer's (O.E.M.) parts only, listed in this manual. "Use of parts which do not meet the original equipment specifications may lead to improper performance and compromise safety!"

10. Do not change the engine governor setting or overspeed the engine. The governor controls the maximum safe operating speed of the engine.
11. Maintain or replace safety and instruction labels, as necessary.
12. Observe proper disposal laws and regulations. Improper disposal of fluids and materials can harm the environment.
13. ALWAYS de-energize self starter prior to performing any maintenance or service to the engine and or mower. Follow instructions both in manual and on the engine and or machine to de-energize starter.

Your Responsibility

- Restrict the use of this power machine to persons who read, understand and follow the warnings and instructions in this manual and on the machine.



SECTION 2: SLOPE GAUGE

Use this page as a guide to determine slopes where you may not operate the lawn mower safely.

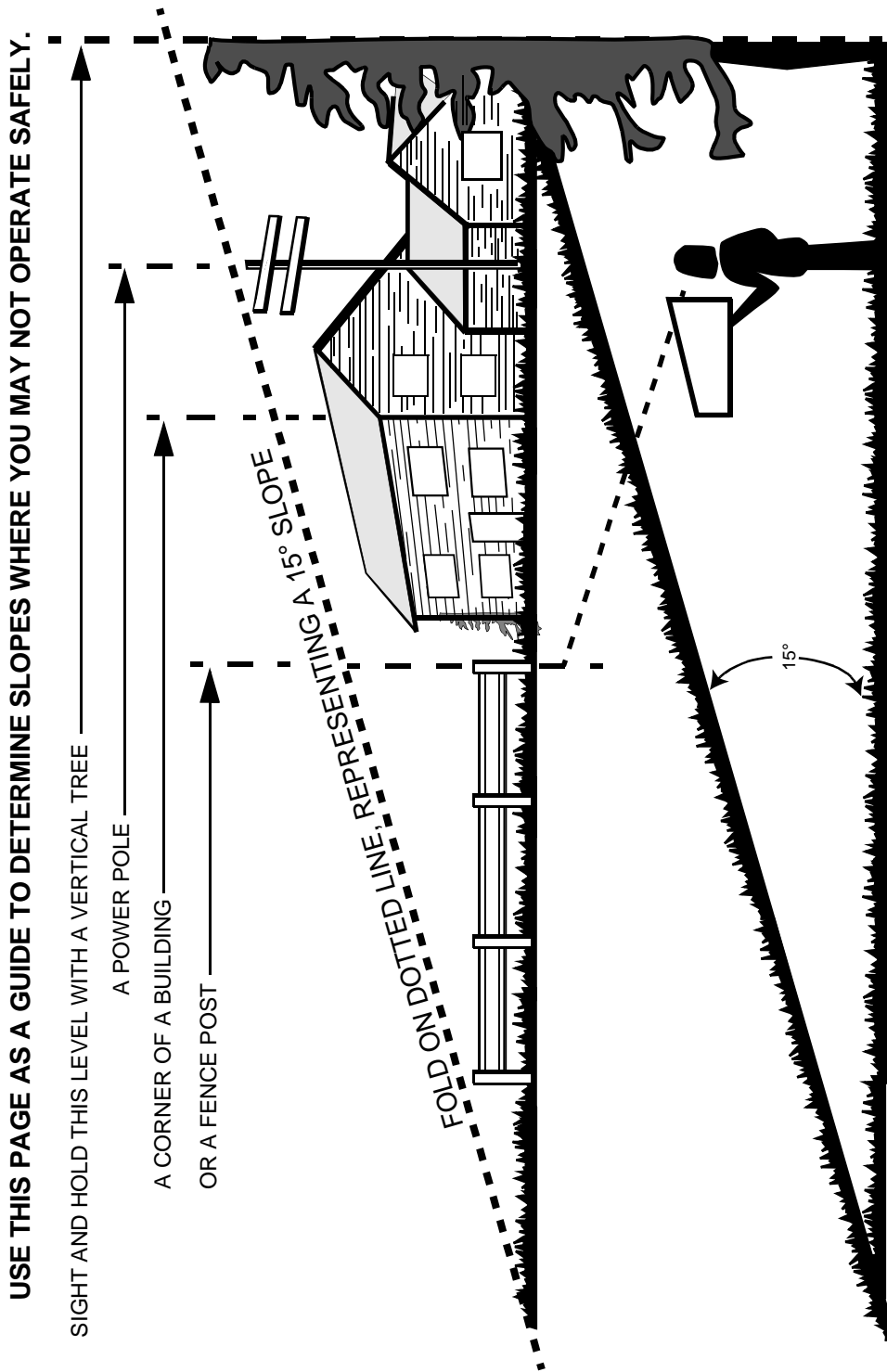

WARNING

Do not mow on inclines with a slope in excess of 15 degrees (a rise of approximately 2-1/2 feet every 10 feet). A riding mower could overturn and cause serious injury. If operating a walk-behind mower on such a slope, it is extremely difficult to maintain your footing and you could slip, resulting in serious injury. Operate RIDING mowers up and down slopes, never across the face of slopes. Operate WALK-BEHIND mowers across the face of slopes, never up and down slopes.

SECTION 3: UNPACKING

Removing Unit From Carton

- Remove staples, break glue on top flaps, or cut tape at carton end and peel along top flap to open carton.

- Remove loose parts if included with unit (i.e., operators manual, bottle of oil, etc.).
- Cut corners and lay carton down flat.
- Remove packing material.
- Roll unit out of carton. Check carton thoroughly for loose parts.

SECTION 4: ASSEMBLING YOUR LAWN MOWER

IMPORTANT: This unit is shipped without gasoline or oil. Be certain to service engine with gasoline and oil as instructed in the separate engine manual before operating your mower.

NOTE: Reference to right or left hand side of the mower is observed from the operating position.

Tools Required

Pair of pliers (not necessary, but helpful)



WARNING: Disconnect the spark plug wire and ground it against the engine to prevent unintended starting. Leave safety key in locked position.

Assembling Mower

- Remove any packing material which may be between the upper and lower handles for shipping purposes.
- Disconnect spark plug wire from the spark plug and ground it against the engine.
- Pull up and back on the upper handle to raise the handle into the operating position. Make certain the lower handle is seated securely into the handle mounting brackets. Tighten the hand knobs on each side of the handle (carriage bolts must be seated properly on the handle). See Figure 1.

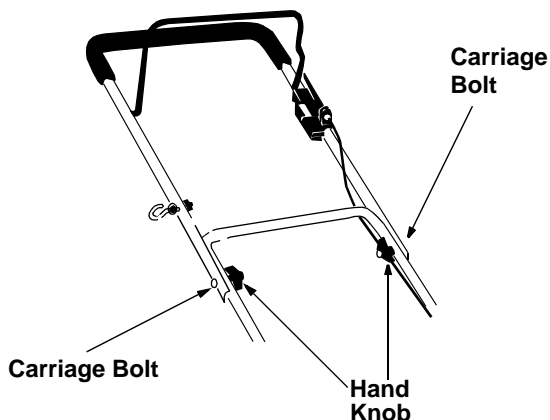

Figure 1

NOTE: Your mower is shipped with the handle in the higher height position. If you wish to lower the height of the handle, refer to the Handle Height Adjustment Section on page 11.

- Remove the hairpin clips from the outer holes in the weld pins on the handle mounting brackets.
- Using a pair of pliers, squeeze one leg of the lower handle against the handle mounting bracket. Insert the hairpin clip into the inner hole on the weld pin. See Figure 2. Repeat on other side.

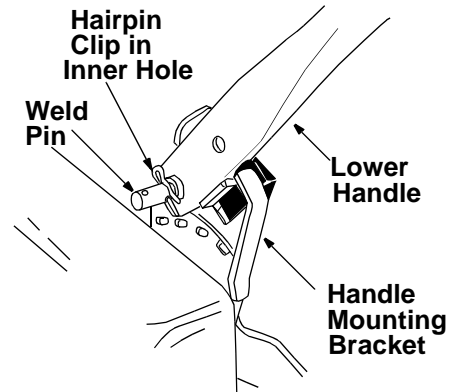

Figure 2

- Insert post on cable ties into holes provided on the lower handle. Pull the cable tie tight and trim the excess. See Figure 3.

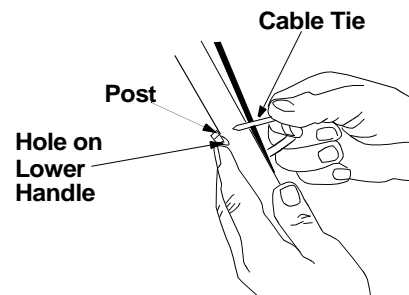

Figure 3

- The rope guide is attached to the right side of the upper handle. Loosen the wing nut which secures the rope guide. For location of the wing nut, see Figure 4.

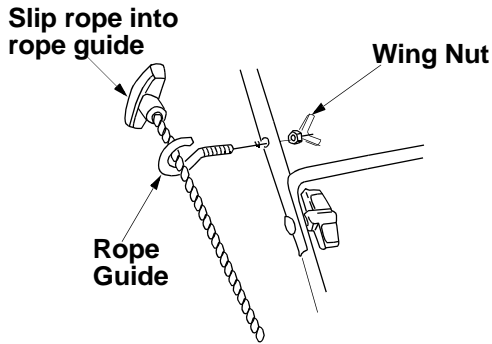

Figure 4

- With the spark plug wire disconnected and grounded, and with the safety key in the locked position, pull the starter rope out of the engine. Slip the starter rope into the rope guide. Tighten the wing nut. See Figure 4.
- Make certain all nuts and bolts are tightened securely.

- Your mower has been shipped as a mulcher. To convert it to a side-discharge mower, lift the mulching plug. Slide the two hooks on the side-discharge deflector under the hinge pin on the mulching plug assembly. Lower the mulching plug. See Figure 5.

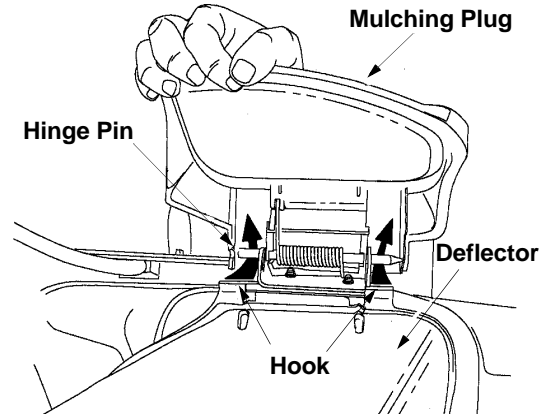

Figure 5

SECTION 5: KNOW YOUR LAWN MOWER



WARNING: Be familiar with all controls and their proper operation. Know how to stop the machine and disengage them quickly.

Blade Control Handle

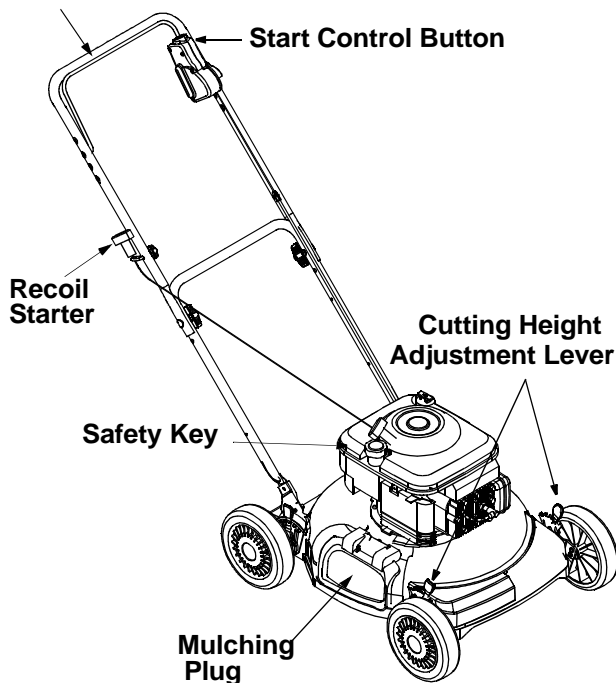

Figure 6

Blade Control Handle



WARNING: The blade control handle is a safety device. Never attempt to bypass its operations. Doing so, may result in personal injury through contact with the rotating blade. The blade rotates whenever the engine is running and when the self starter is de-energized.

The blade control handle is located on the upper handle of the mower. See Figure 6. The blade control handle and starter control button must be depressed in order to operate the unit. Release the blade control handle to stop the engine and blade and to energize the self starter.

Recoil Starter

The recoil starter handle is attached to the upper handle. See Figure 6. The recoil starter is used to start the engine when the self starter is in the de-energized mode.

Safety Key

The safety key is located on the engine. See Figure 6. The safety key is a safety device used to activate and deactivate the self starter system. The self starter system will not work without the key in its proper position. See engine manual for further information pertaining to the safety key.

NOTE: The safety key must be in the run position to start the mower for both systems, either the self starter or recoil starter.

Start Control Button

The start control button is located on the upper left side of the handle. See Figure 6. The start control button must be depressed fully while pulling the blade control handle toward upper handle for the engine to start. The

starter control button will automatically return to the off/up position once the blade control handle is released.

NOTE: The starter button must be depressed to start the engine with either the self starter or recoil starting system.

SECTION 6: OPERATING YOUR LAWN MOWER



WARNING: Read, understand, and follow all instructions and warnings on the machine and in this manual before operating.

Keep hands and feet away from the discharge area on and from under the cutting deck. See safety labels on page 5.

The operation of any lawn mower can result in foreign objects being thrown into the eyes, which can result in severe eye damage. Always wear safety glasses or eye shields.

NOTE: For best results raise the cutting position until it is determined which height is best for your lawn. See *Cutting Height Adjustment* section.

Gas And Oil Fill-Up

Service the engine with gasoline and oil as instructed in the separate engine manual. Read instructions carefully.



WARNING: Use extreme care when handling gasoline. Gasoline is extremely flammable and the vapors are explosive. Never fuel machine indoors or while the engine is hot or running. Extinguish cigarettes, cigars, pipes, and other sources of ignition.

Before Starting

- Attach spark plug wire to spark plug. If equipped with a rubber boot, make certain the metal loop on the end of the spark plug wire (inside the rubber boot) is fastened securely over the metal tip on the spark plug.

First Time Starting Engine

NOTE: Use recoil starter rope to start engine for the very first time. The mower is shipped with the safety key in the locked position and the self starter in the de-energized mode, follow instructions as follows.

1. Place lawn mower on a level surface outdoors.
2. Remove clear plastic packaging under fuel cap.
3. Check oil level.

4. Add fuel.
5. Open shut off valve (if equipped) 1/4 turn.
6. Push spark plug wire firmly on spark plug.
7. Turn safety key 1/4 turn clockwise to RUN position.
8. Firmly push primer bulb 3 times.
9. While standing in the operating position, depress the starter control button fully with the thumb of your right hand.
10. Using your left hand, pull the control handle all the way toward the upper handle. See Figure 7.
11. Release the button.
12. Grasp the recoil rope starter handle with your right hand and slowly pull towards you until you feel a slight resistance, then pull firmly until your arm is fully extended.
13. If engine does not start by the second pull, repeat steps 8, 9, 10, 11 and 12.

Second Time Starting Engine

NOTE: Follow these instructions if the self starter is already in the energized mode.



WARNING: NEVER assume starter is in the de-energized mode, even if the key is in the locked position and/or removed from the engine. ALWAYS de-energize starter prior to performing any maintenance or service to the engine and/or mower. Follow instructions on the engine and/or machine to de-energize starter.

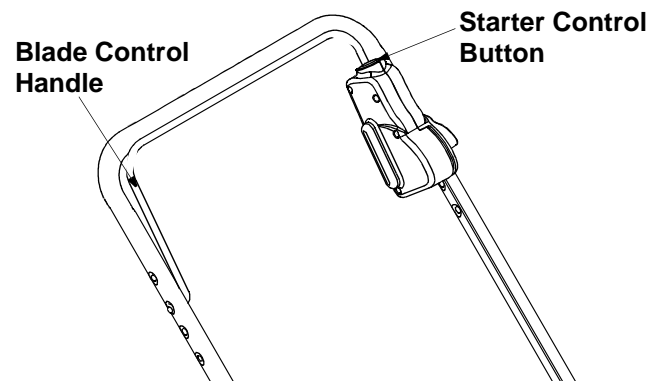

Figure 7

1. Check oil level and add fuel, if necessary.
2. Open shut off valve (if equipped) 1/4 turn.
3. Turn safety key 1/4 turn clockwise to RUN position.
4. Firmly push primer bulb 3 times (For a cold engine only!).
5. While standing at upper handle, depress the starter control button with the thumb of your right hand.
6. Using your left hand, pull the blade control handle all the way toward the upper handle. See Figure 7. Starter will de-energize and engine will start.
(**NOTE:** If engine does not start, release the blade control handle and follow steps 8, 9, 10, 11 and 12 in the "First Time Starting Engine" instructions.)

NOTE: If any problems are encountered, refer to the Trouble Shooting Guide for helpful information.

To Stop Engine And Blade

1. Release safety blade control handle (the start control button will automatically return to the off/up position), engine and blade will stop within a few seconds.

NOTE: Engine may stop with a ratcheting sound. This sound is the self starter being reactivated/energized for the next start.

2. Turn safety key 1/4 turn counterclockwise to LOCK position. Remove key and store in a safe place.



WARNING: The blade will continue to rotate for three seconds after the blade control lever is released.

To De-Energize Self Starter

- Remove spark plug wire from spark plug.
- Turn safety key to RUN position (1/4 turn clockwise).
- While standing in the operating position, depress the starter control button fully with the thumb of your right hand.
- Using your left hand, pull the control handle all the way toward the upper handle. (Release button and wait until engine and starter stop rotating.)
- Release safety blade control handle (the start control button will automatically return to the off/up position.)
- Remove safety key.

NOTE: Engine will crank over upon actuating equipment starting controls, but will not spark if spark plug wire was removed from spark plug as described above. Once engine has stopped cranking, self starter is de-energized.



WARNING: Self Starting System: If these instructions are not followed, amputation or severe laceration can result.

- ALWAYS disconnect spark plug, de-energize starter, lock and remove safety key BEFORE performing ANY service to the engine or mower.
- DO NOT attempt any maintenance or repairs to the self starter.
- NEVER assume starter is de-energized, even if key is in LOCK AND REMOVE position and/or removed from engine.
- BEFORE removing grass or other debris from under mower deck; BEFORE changing oil, air filter or spark plug; BEFORE removing blade for servicing; BEFORE performing any other service to engine or mower; BEFORE transporting mower- ALWAYS DE-ENERGIZE SELF STARTER.
- ALWAYS lock and remove safety key and store in a safe place until next use. The safety key is designed and intended to be removed from engine when not in use. Removing key will prevent unsupervised or unexpected starting of mower by children or unsuspecting adults. The safety key must be in the locked position before it can be removed.

Using Your Rotary Mower

- Thoroughly inspect the area where the equipment is to be used. Remove all stones, sticks, wire, bones, toys and other foreign objects which could be tripped over or picked up and thrown by the blade. Thrown objects can cause serious personal injury.
- For best results, do not cut wet grass because it tends to stick to the underside of the mower, preventing proper discharge of grass clippings, and could cause you to slip and fall. New grass, thick grass or wet grass may require a narrower cut.
- When using side-discharge mower, the best mowing pattern is one that allows the clippings to discharge towards the uncut part of the lawn. This permits recutting of the clippings to further pulverize them. When cutting high weeds, discharge towards cut portion, then recut at right angles to first direction.
- For a healthier lawn, always cut off one-third or less of the total length of the grass. Lawn should be cut in the fall as long as there is growth.



WARNING: If you strike a foreign object, stop the engine. Remove wire from spark plug and de-energize, thoroughly inspect the mower for any damage, and repair the damage before restarting and operating the mower. Excessive vibration of the mower during operation is an indication of damage. The unit should be promptly inspected and repaired.

SECTION 7: MAKING ADJUSTMENTS



WARNING: Be sure to disconnect the spark plug wire and DE-ENERGIZE starter before performing any adjustments or repairs. DO NOT attempt any maintenance or service to the engine and/or mower equipped with the safety key in the unlocked and/or energized mode.



WARNING: NEVER assume starter is de-energized, even if the key is in the locked position and/or removed from the engine. ALWAYS de-energize self starter prior to performing any maintenance or service to the engine and/or mower. Follow instructions on the engine and/or machine to de-energize starter.

Cutting Height Adjustment

There is an adjusting plate and thumb lever at each wheel position to adjust the cutting height. Each adjusting plate has nine height positions. Height of cut will change if you move the thumb lever from one hole to another.

Simply depress the lever towards wheel and move the wheel and lever assembly to the desired position. All wheels must be placed in the same relative position for uniform cutting height. See Figure 8.

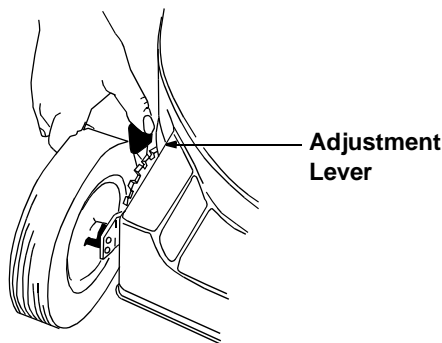

Figure 8

For rough or uneven lawns, move the height adjustment handles to positions which will give a higher cutting height. Both front and rear handles must be placed in the same relative position.

Handle Height Adjustment

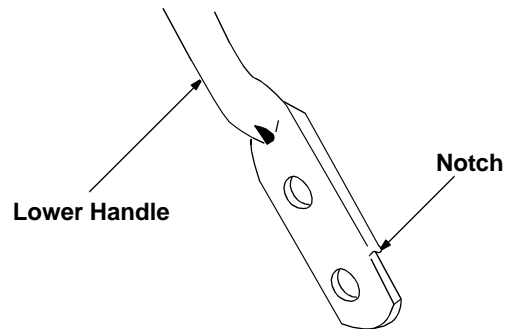

Figure 9

Your mower is shipped with the handle in the higher height position. To lower the handle height, proceed as follows.

- Remove the starter rope from the rope guide.
- Remove the upper handle by removing the hand knobs and carriage bolts. Lay the upper handle out of the way, being careful not to bend or kink the cable.
- Remove the hairpin clips from the weld pins on the handle brackets. Press inward on the legs of the lower handle. Remove lower handle from the mower.
- Turn the lower handle around so the notch on the bottom of the lower handle is facing forward as shown in Figure 9. Reassemble, placing the bottom holes in the handle over the weld pins in the handle mounting bracket.
- Reassemble the upper handle.
- Place the hairpin clips in the inner holes in the weld pins and attach the starter rope as instructed in the Set-Up Instructions.

SECTION 8: SERVICE



WARNING: Be sure to disconnect the spark plug wire and DE-ENERGIZE starter before lubricating, repairing or servicing. DO NOT attempt any maintenance or service to the engine and/or mower equipped with the safety key in the unlocked and/or energized mode.



WARNING: NEVER assume starter is de-energized, even if the key is in the locked position and/or removed from the engine. ALWAYS de-energize self starter prior to performing any maintenance or service to the engine and/or mower. Follow instructions on the engine and/or machine to de-energize starter.

Blade Control Handle

Lubricate the pivot points on the blade control handle at least once a season with light oil. See Figure 10. The blade control must operate freely in both directions. Also, lubricate the pivot points on the mulch baffle and the height adjustment lever.

Wheels

Lubricate the wheel bearings (if so equipped) at least once a season with light oil (or engine oil). Also, if the wheels are removed for any reason, lubricate the surface of the axle bolt and the inner surface of the wheel with light oil

Engine

Follow engine manual for lubrication instructions.

Lubrication Chart:

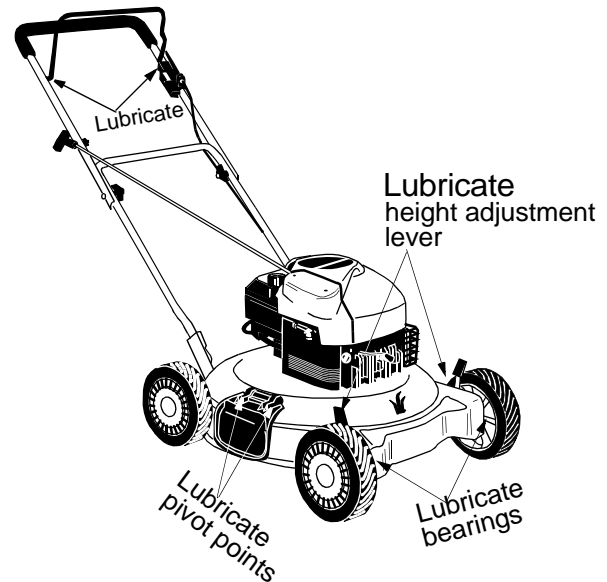

Figure 10

SECTION 9: MAINTAINING YOUR LAWN MOWER



WARNING: Be sure to disconnect the spark plug wire and DE-ENERGIZE starter before performing any repairs or maintenance. DO NOT attempt any maintenance or service to the engine and/or mower equipped with the safety key in the unlocked and/or energized mode.



WARNING: NEVER assume starter is de-energized, even if the key is in the locked position and/or removed from the engine. ALWAYS de-energize self starter prior to performing any maintenance or service to the engine and/or mower. Follow instructions on the engine and/or machine to de-energize starter.

NOTE: When tipping the unit, empty the fuel tank and keep engine spark plug side up.

Cutting Blade



WARNING: When removing the cutting blade for sharpening or replacement, protect hands by using heavy gloves or a rag to grasp the cutting blade.

To remove blade

- Remove the bolt and blade bell support which hold the blade and adapter to the engine crankshaft. See Figure 11. Remove the blade and the adapter from the crankshaft.

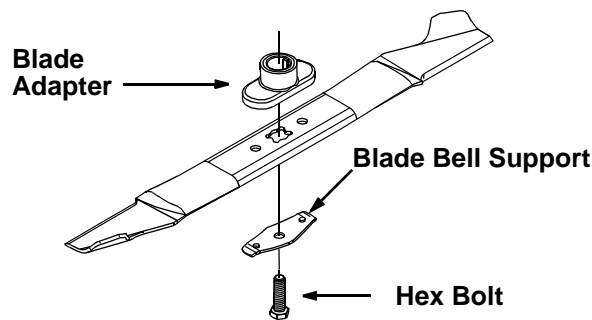

Figure 11



WARNING: Periodically inspect the blade adapter for cracks, especially if you strike a foreign object. Replace when necessary.

- When sharpening the blade, follow the original angle of grind as a guide. It is extremely important that each cutting edge receives an equal amount of grinding to prevent an unbalanced blade. An unbalanced blade will cause excessive vibration when rotating at high speeds, may cause damage to the mower and could break, causing personal injury.
- The blade can be tested by balancing it on a round shaft screwdriver. Remove metal from the heavy side until it balances evenly. It is recommended that the blade always be removed from the adapter for the best test of balance.
- Before reinstalling the blade and the blade adapter to the unit, lubricate the engine crankshaft and the inner surface of the blade adapter with light oil (or engine oil). Lubricating the bolt holes, bolts and inner surface of the nuts is also recommended.

To Reinstall Blade

- Be sure to install the blade with the side of the blade marked "Bottom" (or with part number) facing the ground when the mower is in the operating position.
- Be certain the blade is aligned with and seated onto the blade adapter flanges.
- Place blade bell support on blade. Make sure the notches on the blade bell support are aligned with the small hole in the blade.

- Replace hex bolt.
- Tighten to torque: 450 in. lbs. min., 600 in. lbs. max.
- To ensure safe operation of mower, check all nuts and bolts periodically for correct torque.

Deck Maintenance

- The underside of the mower deck should be cleaned after each use to prevent a buildup of grass clippings, leaves, dirt or other matter. If this debris is allowed to accumulate, it will invite rust and corrosion, and may prevent proper mulching.
- The deck may be cleaned by tilting the mower and scraping clean with a suitable tool (make certain the spark plug wire is disconnected). Do not use high pressure cleaners or water.
- We do not recommend the use of pressure washers or garden hose to clean your unit. They may cause damage to electric components, spindles, pulleys, bearings or the engine. The use of water will result in shortened life and reduce serviceability.

Engine Maintenance

- Refer to the separate engine manual for all engine maintenance instructions.
- Maintain ENGINE OIL as instructed in the engine manual.
- Service AIR CLEANER every 25 hours under normal conditions. Clean every few hours under extremely dusty conditions. Poor engine performance and flooding usually indicates that the air cleaner should be serviced. To service the air cleaner, refer to the engine manual.
- The SPARK PLUG should be cleaned and the gap reset once a season. Spark plug replacement is recommended at the start of each mowing season; check engine manual for correct plug type and gap specifications.
- CLEAN the engine regularly with a cloth or brush. Keep the cooling system (blower housing area) cleaned to permit proper air circulation which is essential to engine performance and life. Be certain to remove all grass, dirt and combustible debris from muffler area.

SECTION 10: OFF-SEASON STORAGE

The following steps should be taken to prepare lawn mower for storage.



WARNING: Be sure to disconnect the spark plug wire and DE-ENERGIZE starter before performing any repairs or maintenance. DO NOT attempt any maintenance or service to the engine and/or mower equipped with the safety key in the unlocked and/or energized mode.



WARNING: NEVER assume starter is de-energized, even if the key is in the locked position and/or removed from the engine. ALWAYS de-energize self starter prior to performing any maintenance or service to the engine and/or mower. Follow instructions on the engine and/or machine to de-energize starter.



WARNING: Never store the machine or fuel container indoors where there is an open flame, spark or pilot light such as on water heater, furnace, clothes dryer or other gas appliance.

- Clean and lubricate mower thoroughly as described in the lubrication instructions.

NOTE: *We do not recommend the use of pressure washers or garden hose to clean your unit. They may cause damage to electric components, spindles, pulleys, bearings or the engine. The use of water will result in shortened life and reduce serviceability.*

- Refer to engine manual for correct engine storage instructions.
- Coat mower's cutting blade with chassis grease to prevent rusting.
- Store mower in a dry, clean area. Do not store next to corrosive materials, such as fertilizer.

NOTE: *When storing any type of power equipment in an unventilated or metal storage shed, care should be taken to rust-proof the equipment. Using a light oil or silicone, coat the equipment, especially cables and all moving parts.*

SECTION 11: TROUBLE SHOOTING GUIDE

| Trouble | Possible Cause(s) | Corrective Action |
|---|---|---|
| Engine fails to start | Blade control handle disengaged. Start control button not depressed. Spark plug wire disconnected. Safety key not in run position. Fuel tank empty, or stale fuel. Blocked fuel line. Faulty spark plug. Engine flooded. Engine not primed. Self starter already de-energized. | Engage blade control handle. Depress starter control button. Connect wire to spark plug. Place safety key in run position. Fill tank with clean, fresh gasoline. Clean fuel line. Clean, adjust gap or replace. Wait a few minutes. Push primer bulb three times to prime engine. Use recoil starter to start engine |
| Engine runs erratic | Spark plug wire loose. Blocked fuel line or stale fuel. Vent in gas cap plugged. Water or dirt in fuel system. Dirty air cleaner. Carburetor out of adjustment. | Connect and tighten spark plug wire. Clean fuel line; fill tank with clean, fresh gasoline. Clear vent. Drain fuel tank. Refill with fresh fuel. Clean air cleaner. Adjust carburetor. |
| Engine overheats | Engine oil level low. Air flow restricted. Carburetor not adjusted properly. | Fill crankcase with proper oil. Remove blower housing and clean. Adjust carburetor. |
| Occasional skip (hesitates) at high speed | Spark plug gap too close. | Adjust gap to .030". |
| Idles poorly | Spark plug fouled, faulty or gap too wide. Carburetor improperly adjusted. Dirty air cleaner. | Reset gap to .030" or replace spark plug. Adjust carburetor. Clean air cleaner. |
| Excessive vibration | Cutting blade loose or unbalanced. Bent cutting blade. | Tighten blade and adapter. Balance blade. Replace blade. |
| Mower will not mulch grass | Wet grass. Excessively high grass. Dull blade. | Do not mow when grass is wet; wait until later to cut. Mow once at a high cutting height, then mow again at desired height or make a narrower cutting swath (1/2 width). Sharpen or replace blade. |
| Uneven cut | Wheels not positioned correctly. Dull blade. | Place all four wheels in same height position. Sharpen or replace blade. |

Refer to separate engine manual packed with your mower for more engine related information.

NOTE: For repairs beyond the minor adjustments listed above, contact your nearest authorized service dealer.

Model 109T

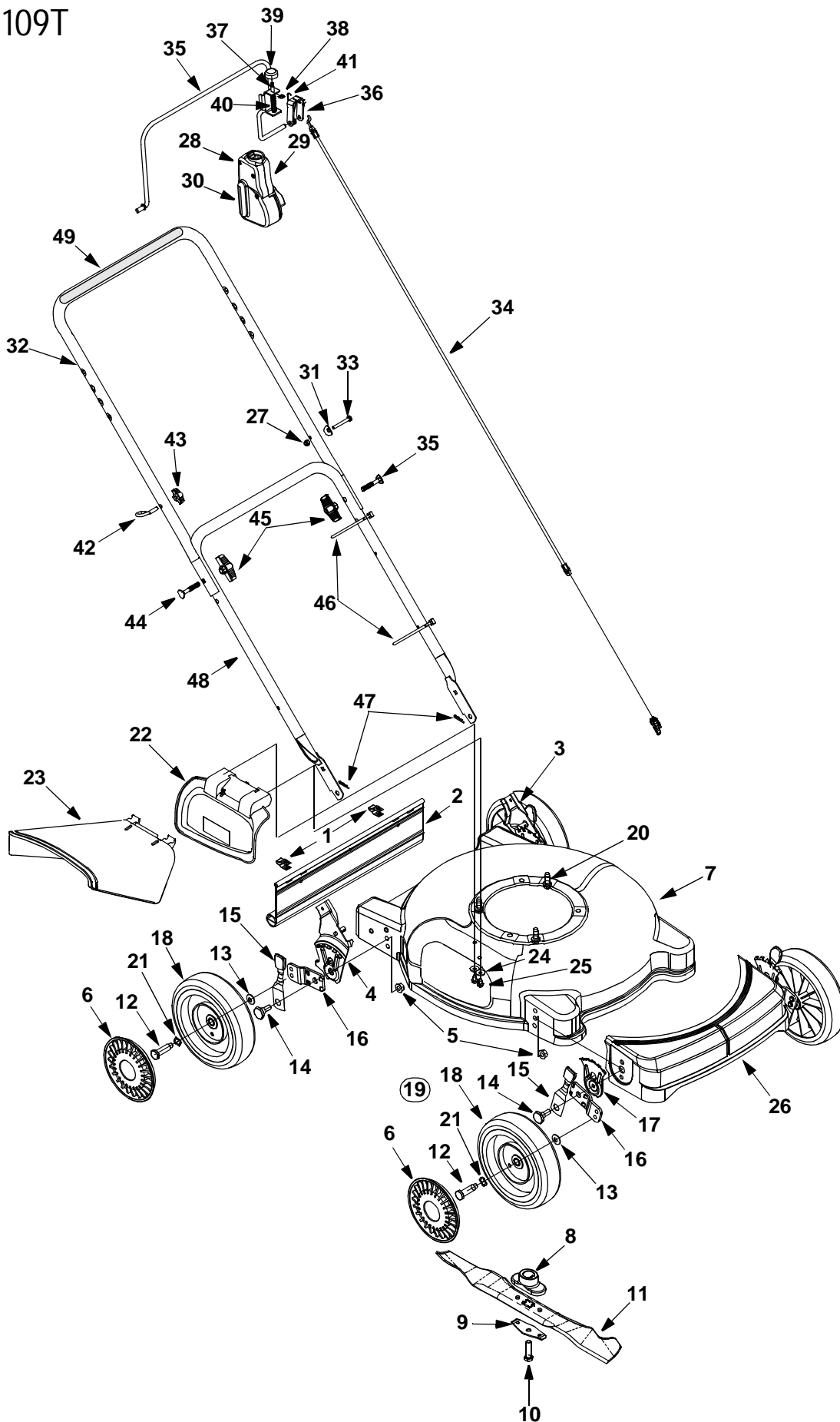

Model 109T

| Ref. No. | Part No. | Part Description | Ref. No. | Part No. | Part Description |
|----------|-----------|---|----------|----------|--------------------------------|
| 1. | 17098 | Hinge Clip | 26. | 731-1933 | Cover: Front End |
| 2. | 731-0872A | Rear Flap | 27. | 712-0324 | Hex Lock Nut 1/4-20 Gr. 8 |
| 3. | 682-3025 | Handle Bracket Ass'y LH | 28. | 710-1256 | Hi-Low Screw |
| 4. | 682-3024 | Handle Bracket Ass'y RH | 29. | 731-2532 | Control Cover LH |
| 5. | 712-0431 | Flange Lock Nut 3/8-16 | 30. | 731-2533 | Control Cover RH |
| 6. | 731-1426 | Hub Cap-Yellow | 31. | 736-0451 | Saddle Washer |
| 7. | 682-0139 | Deck Assembly | 32. | 749-1406 | Upper Handle |
| 8. | 753-0588 | Blade Adapter Kit | 33. | 710-0501 | Hex Hd. Cap Screw 1/4-20 Gr. 5 |
| 9. | 736-0524A | Blade Bell Support | 34. | 746-1141 | Control Cable 56.75" Lg. |
| 10. | 710-1044 | Hex Bolt 7/16-20 x .88" | 35. | 647-0058 | Control Bail Lever |
| 11. | 742-0740 | 20" Mulch Blade | 36. | 782-0156 | Lever |
| 12. | 738-0102 | Axle Bolt | 37. | 715-0168 | Pin |
| 13. | 736-0105 | Bell Washer .400" ID x .88" | 38. | 716-0209 | Retention Ring |
| 14. | 738-0507B | Shoulder Bolt | 39. | 720-0428 | Button |
| 15. | 14832 | Spring Lever Ass'y w/Knob | 40. | 732-1171 | Compression Spring |
| 16. | 15262B | Pivot Bar | 41. | 732-1172 | Torsion Spring |
| 17. | 15261A | Height Adj. Plate | 42. | 710-1205 | Rope Guide |
| 18. | 734-1978 | Wheel Assembly | 43. | 720-0279 | Handle Knob |
| 19. | 14578 | Height Adj. Ass'y Comp. | 44. | 710-1174 | Carriage Bolt |
| | 14579 | Height Adj. Ass'y Comp. | 45. | 720-0314 | Hand Knob |
| 20. | 710-0654A | Hex Lock Wash. Hd. Screw | 46. | 726-0240 | Cable Tie |
| 21. | 736-0504 | Wave Washer | 47. | 714-0104 | Hairpin Clip |
| 22. | 682-7002 | Mulching Plug | 48. | 749-0928 | Lower Handle |
| 23. | 731-1409 | Chute Deflector | 49. | 720-0295 | Foam Grip |
| 24. | 736-0270 | Bell Washer | - | 737-0208 | Bottle of Oil (not shown) |
| 25. | 710-0599 | Hex Wash. Hd. TT Screw 1/4-20 x .5" Lg. | | | |

MANUFACTURER'S LIMITED WARRANTY FOR:



The limited warranty set forth below is given by MTD PRODUCTS INC ("MTD") with respect to new merchandise purchased and used in the United States, its possessions and territories.

MTD warrants this product against defects in material and workmanship for a period of two (2) years commencing on the date of original purchase and will, at its option, repair or replace, free of charge, any part found to be defective in material or workmanship. This limited warranty shall only apply if this product has been operated and maintained in accordance with the Operator's Manual furnished with the product, and has not been subject to misuse, abuse, commercial use, neglect, accident, improper maintenance, alteration, vandalism, theft, fire, water or damage because of other peril or natural disaster. Damage resulting from the installation or use of any accessory or attachment not approved by MTD Products Inc. for use with the product(s) covered by this manual will void your warranty as to any resulting damages.

Normal wear parts or components thereof are subject to separate terms as follows: All normal wear part or component failures will be covered on the product for a period of 90 days regardless of cause. After 90 days, but within the two year period, normal wear part failures will be covered ONLY IF caused by defects in material or workmanship of OTHER component parts. Normal wear parts and components include, but are not limited to, belts, blades, blade adapters, grass bags, rider deck wheels, seats, snow thrower skid shoes, shave plates and tires. Batteries are covered by a 90-day limited replacement warranty.

HOW TO OBTAIN SERVICE: Warranty service is available, WITH PROOF OF PURCHASE THROUGH YOUR LOCAL AUTHORIZED SERVICE DEALER. To locate the dealer in your area, please check for a listing in the Yellow Pages or contact the Customer Service Department of MTD PRODUCTS INC by calling 1-800-800-7310 or writing to P.O. Box 368022, Cleveland, Ohio 44136-9722.

This limited warranty does not provide coverage in the following cases:

- a. The engine or component parts thereof. These items carry a separate manufacturer's warranty. Please refer to the applicable manufacturer's warranty on these items.
- b. Log splitter pumps, valves and cylinders have a separate one year warranty.

c. Routine maintenance items such as lubricants, filters, blade sharpening and tune-ups, or adjustments such as brake adjustments, clutch adjustments or deck adjustments; and normal deterioration of the exterior finish due to use or exposure.

d. MTD does not extend any warranty for products sold or exported outside of the United States of America, its possessions and territories, except those sold through MTD's authorized channels of export distribution.

No implied warranty, including any implied warranty of merchantability or fitness for a particular purpose, applies after the applicable period of express written warranty above as to the parts as identified. No other express warranty or guaranty, whether written or oral, except as mentioned above, given by any person or entity, including a dealer or retailer, with respect to any product shall bind MTD. During the period of the Warranty, the exclusive remedy is repair or replacement of the product as set forth above. (Some states do not allow limitations on how long an implied warranty lasts, so the above limitation may not apply to you.)

The provisions as set forth in this Warranty provide the sole and exclusive remedy arising from the sales. MTD shall not be liable for incidental or consequential loss or damages including, without limitation, expenses incurred for substitute or replacement lawn care services, for transportation or for related expenses, or for rental expenses to temporarily replace a warranted product. (Some states do not allow the exclusion or limitation of incidental or consequential damages, so the above exclusion or limitation may not apply to you.)

In no event shall recovery of any kind be greater than the amount of the purchase price of the product sold. Alteration of the safety features of the product shall void this Warranty. You assume the risk and liability for loss, damage, or injury to you and your property and/or to others and their property arising out of the use or misuse or inability to use the product.

This limited warranty shall not extend to anyone other than the original purchaser, original lessee or the person for whom it was purchased as a gift.

How State Law Relates to this Warranty: This limited warranty gives you specific legal rights, and you may also have other rights which vary from state to state.