

BUNN®

AF PR-2

AF PR-3

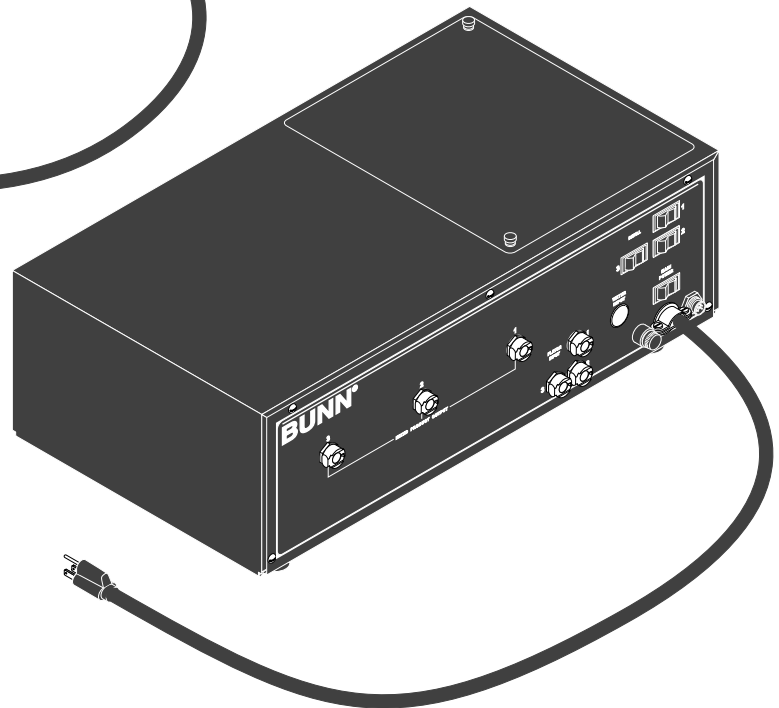
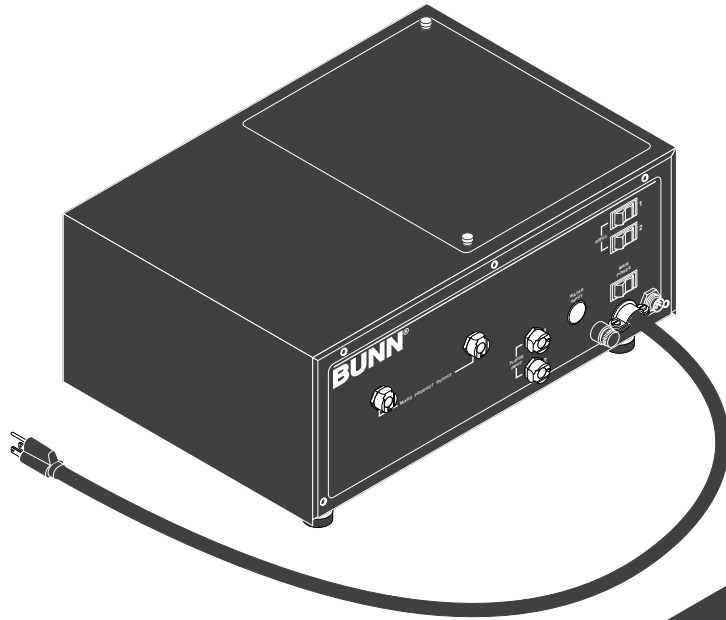

OPERATING & SERVICE MANUAL

BUNN-O-MATIC CORPORATION

POST OFFICE BOX 3227

SPRINGFIELD, ILLINOIS 62708-3227

PHONE: (217) 529-6601 FAX: (217) 529-6644

INTRODUCTION

This equipment supplies a premixed liquid product to the hoppers on the CDS-2 or 3 dispensers. It is for indoor use only on a sturdy counter or shelf.

WARRANTY

Bunn-O-Matic Corp. ("Bunn") warrants the equipment manufactured by it to be commercially free from defects in material and workmanship existing at the time of manufacture and appearing within one year from the date of installation. In addition:

1.) Bunn warrants electronic circuit and/or control boards to be commercially free from defects in material and workmanship for two years from the date of installation.

2.) Bunn warrants the compressor on refrigeration equipment to be commercially free from defects in material and workmanship for two years from the date of installation.

3.) Bunn warrants that the grinding burrs on coffee grinding equipment will grind coffee to meet original factory screen sieve analysis for three years from date of installation or for 30,000 pounds of coffee, whichever comes first.

This warranty does not apply to any equipment, component or part that was not manufactured by Bunn or that, in Bunn's judgement, has been affected by misuse, neglect, alteration, improper installation or operation, improper maintenance or repair, damage or casualty.

THE FOREGOING WARRANTY IS EXCLUSIVE AND IS IN LIEU OF ANY OTHER WARRANTY, WRITTEN OR ORAL, EXPRESS OR IMPLIED, INCLUDING, BUT NOT LIMITED TO, ANY IMPLIED WARRANTY OF EITHER MERCHANTABILITY OR FITNESS FOR A PARTICULAR PURPOSE. The agents, dealers or employees of Bunn are not authorized to make modifications to this warranty or to make additional warranties that are binding on Bunn. Accordingly, statements by such individuals, whether oral or written, do not constitute warranties and should not be relied upon.

The Buyer shall give Bunn prompt notice of any claim to be made under this warranty by telephone at (217) 529-6601 or by writing to Post Office Box 3227, Springfield, Illinois, 62708-3227. If requested by Bunn, the Buyer shall ship the defective equipment prepaid to an authorized Bunn service location. If Bunn determines, in its sole discretion, that the equipment does not conform to the warranty, Bunn shall repair the equipment with no charge for parts during the warranty period and no charge for labor by a Bunn Authorized Service Representative during the warranty period. If Bunn determines that repair is not feasible, Bunn shall, at its sole option, replace the equipment or refund the purchase price for the equipment.

THE BUYER'S REMEDY AGAINST BUNN FOR THE BREACH OF ANY OBLIGATION ARISING OUT OF THE SALE OF THIS EQUIPMENT, WHETHER DERIVED FROM WARRANTY OR OTHERWISE, SHALL BE LIMITED, AS SPECIFIED HEREIN, TO REPAIR OR, AT BUNN'S SOLE OPTION, REPLACEMENT OR REFUND.

In no event shall Bunn be liable for any other damage or loss, including, but not limited to, lost profits, lost sales, loss of use of equipment, claims of Buyer's customers, cost of capital, cost of down time, cost of substitute equipment, facilities or services, or any other special, incidental or consequential damages.

USER NOTICES

Carefully read and follow all notices on the equipment and in this manual. They were written for your protection. All notices are to be kept in good condition. Replace any unreadable or damaged labels.

This equipment is to be installed to comply with the Basic Plumbing Code of the Building Officials and Code Administrators International, Inc. (BOCA) and the Food Service Sanitation Manual of the Food and Drug Administration (FDA).

00656.0000

⚠ WARNING
<ul style="list-style-type: none">• DO NOT OVERLOAD CIRCUIT.• ALWAYS ELECTRICALLY GROUND THE CHASSIS OR ADAPTOR PLUG.• DO NOT DEFORM PLUG OR CORD.• FOLLOW NATIONAL AND LOCAL ELECTRICAL CODES.• KEEP COMBUSTIBLES AWAY.
FAILURE TO COMPLY RISKS EQUIPMENT DAMAGE, FIRE, OR SHOCK HAZARD.
READ THE ENTIRE OPERATING MANUAL BEFORE USING THIS PRODUCT
<small>00986.0002E 5/98 © 1994 Bunn-O-Matic Corporation</small>

00986.0002

INITIAL SET-UP

NOTE: This refill unit should not be used to initially fill the hopper. Running the motor for extended periods will trip the thermal switch. The thermal switch will reset, but requires up to 30 minutes of cooling time.

NOTE: Hoses, clamps and product container connectors are not supplied. Fittings and labels are supplied. Make hose assemblies as required.

1. Assemble hoppers with probe housing assemblies to CDS-2, CDS-3 or modify existing hoppers using template provided.
2. Make sure probe housing assembly is pushed down into slots on back of hoppers.
3. Install cable assembly to the lower right front of the auto refill box and the probe housing assemblies on the hoppers. The connectors on the cable pushes in and cap rotates 1/4 turn to lock into position.
4. Run output tubes from auto refill box to the quick disconnects in the hoppers.
NOTE: Make sure numbers on the labels match up. Cable#1 with Hose#1, Cable#2 with Hose#2...ect.
5. Connect one end of input hoses to the auto refill box and the other end to the product container. Product container connectors (BIB) are not supplied. Install your own interface.
NOTE: Make sure all connections are made before connecting the auto refill box to the power source.
6. Each product container has an ON/OFF refill switch located on the front of the auto refill box. A second switch for each hopper is at the probe housing assembly. These are 3 position switches, high level, low level and a center "OFF" position.
7. Place the main ON/OFF switch and ON/OFF refill switches in the "OFF" position.
8. Make sure all hoses are connected. Connect the dispenser to the power source and place the main ON/OFF switch in the "ON" position.
9. Place one of the ON/OFF refill switches in the "ON" position, after a four second delay product will begin to flow through the hoses into the hopper. Be sure the switch selected is filling the correct hopper, if not, check the labels. See **NOTE** in step #4.
10. To test refill circuit short out probes on one of the hoppers with a screwdriver, that hopper should shut off, remove the screwdriver and the hopper will start to fill again after a four second delay. If hopper does not start to fill, check labels, refer to **NOTE** in step #4.

ELECTRICAL REQUIREMENTS

CAUTION - The dispenser must be disconnected from the power source until specified in *Initial Set-Up*.

The 120 volt version of this dispenser has an attached cordset and requires 2-wire, grounded service rated 120 volts ac, 15 amp, single phase, 60 Hz. The mating connector must be a NEMA 5-15R.

The 200 volt or 240 volt versions require 2 wire, grounded service rated 200 volts ac or 240 volts ac, single phase, 50 Hz.

(Refer to the dispenser's data plate for exact voltage requirement.)

ELECTRICAL HOOK-UP

CAUTION – Improper electrical installation will damage electronic components.

1. An electrician must provide electrical service as specified.
2. Using a voltmeter, check the voltage and color coding of each conductor at the electrical source.
3. Connect the dispenser to the power source.

CLEANING

RECOMMENDED WEEKLY CLEANING:

This should be done in conjunction with the recommended weekly cleaning of your CDS-2 or CDS-3 machine. The CDS Hoppers must be empty before starting.

1. Prepare a 1 gallon cleaning solution consisting of 1 gallon of hot water and a sanitizing cleaner which contains 3-5% chlorine based sanitizer. Mix per manufacturers instructions
2. Remove connectors from each concentrate container and place them directly into the cleaning solution.
3. Energize each refill station and allow the cleaning solution to pump through the system into the hoppers. The cleaning procedure should remove the color stains from the tubing. If not, prepare another gallon of cleaning solution and repeat.
4. After the cleaning solution has been pumped into the hoppers, rinse the cleaning solution container with hot water.
5. Fill the cleaning solution container with hot water. Energize each refill station and rinse thoroughly. The amount of clean hot rinse water should equal the amount of cleaning solution pumped through the system.
6. Empty the hoppers of your CDS machine and follow the recommended cleaning instructions.
NOTE: The hoses should be checked monthly for deterioration, cracks and possible discoloration from some concentrates. Replace the tubing when necessary.

TROUBLESHOOTING

A troubleshooting guide is provided to suggest probable causes and remedies for the most likely problems encountered. If the problem remains after exhausting the troubleshooting steps, contact the Bunn-O-Matic Technical Service Department.

- Inspection, testing, and repair of electrical equipment should be performed only by qualified service personnel.
- All electronic components have 120 volt ac and low voltage dc potential on their terminals. Shorting of terminals or the application of external voltages may result in board failure.
- Intermittent operation of electronic circuit boards is unlikely. Board failure will normally be permanent. If an intermittent condition is encountered, the cause will likely be a switch contact or a loose connection at a terminal or crimp.
- Solenoid removal requires interrupting the water supply to the valve. Damage may result if solenoids are energized for more than ten minutes without a supply of water.
- The use of two wrenches is recommended whenever plumbing fittings are tightened or loosened. This will help to avoid twists and kinks in the tubing.
- Make certain that all plumbing connections are sealed and electrical connections tight and isolated.
- Keep away from combustibles.

- WARNING** –
- Exercise extreme caution when servicing electrical equipment.
 - Unplug the dispenser when servicing, except when electrical tests are specified.
 - Follow recommended service procedures
 - Replace all protective shields or safety notices

OPERATING CONTROLS

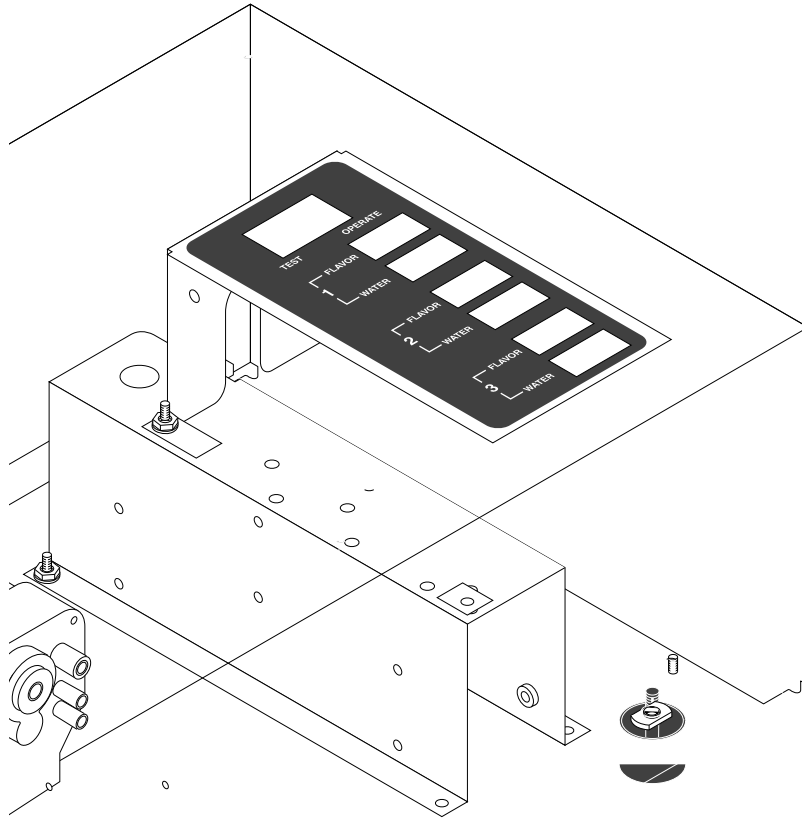

A. MAIN POWER ON/OFF

The main power ON/OFF switch is located on the right of the front panel just above the power cord.

B. REFILL CIRCUIT ON/OFF

The refill circuit ON/OFF switches are located on the right of the front panel just above the main power switch. These allow each circuit to operate independently of the other.

TROUBLESHOOTING (cont.)

PROBLEM	PROBABLE CAUSE	REMEDY
Product will not dispense	1. Empty product container	Replace or refill
	2. No power or incorrect voltage to the dispenser	(A1) Check the outlet for 120 volts on two wire 120 volt dispenser.
		(A2) Check the outlet for 200 volts or 240 volts ac for two wire 200 volt or 240 volt dispensers.
		(B) Check circuit breakers or fuses.
	3. Signal cable unplugged	Signal cable must be plugged in.
	4. Hopper is full	Product must not be touching probes to fill.
	5. Fuse and fuse holder	Refer to <i>Service</i> - Fuse and Fuse Holder for test procedures. See page 8
	6. Main ON/OFF switch	Refer to <i>Service</i> - Main ON/OFF Switch for testing procedure. See page 9
	7. Probe box LOW/OFF/HIGH switches	Refer to <i>Service</i> - Probe System. See page 10
	8. Circuit board	Refer to <i>Service</i> - Circuit Board for testing procedures. See page 7
9. Vacuum switches	Refer to <i>Service</i> - Vacuum Switches for testing procedures. See page 14	
10. Vacuum/Supply pump	Refer to <i>Service</i> - Vacuum/ Supply Pump for testing procedures. See page 12	
Motor thermal cutout (motor stops running)	1. Motor over heats	The thermal switch will reset, but requires up to 30 minutes of cooling time. See NOTE below.

NOTE: This refill unit should not be used to initially fill the hopper. Running the motor for extended periods will trip the thermal switch. The thermal switch will reset, but requires up to 30 minutes of cooling time.

SERVICE

This section provides procedures for testing and replacing various major components used in this dispenser should service become necessary. Refer to *Troubleshooting* for assistance in determining the cause of any problem.

WARNING - Inspection, testing, and repair of electrical equipment should be performed only by qualified service personnel. The dispenser should be unplugged when servicing, except when electrical tests are required and the test procedure specifically states to plug-in the dispenser.

COMPONENT ACCESS

WARNING - Disconnect the dispenser from the power source before the removal of any panel or the replacement of any component.

All components are accessible by removing the eight #8-32 screws (five on the front and three on the rear) securing the main housing to the main mounting panel. Refer to Fig. 1

Refer to the contents listing for component location.

Contents

Circuit Board	8
Fuse & Fuse Holder	9
Main ON/OFF Switch	10
Probe LOW/OFF/HIGH Switches	11
Refill ON/OFF Switches	12
Vacuum/Supply Pump Assembly	13
Vacuum/Supply Pump Tubing Installation	14
Vacuum Switches	15
Wiring Diagrams	16,17

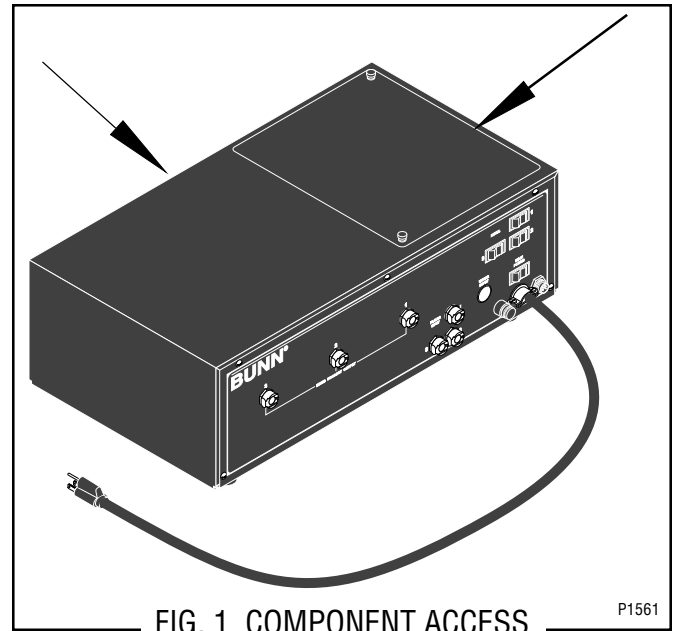
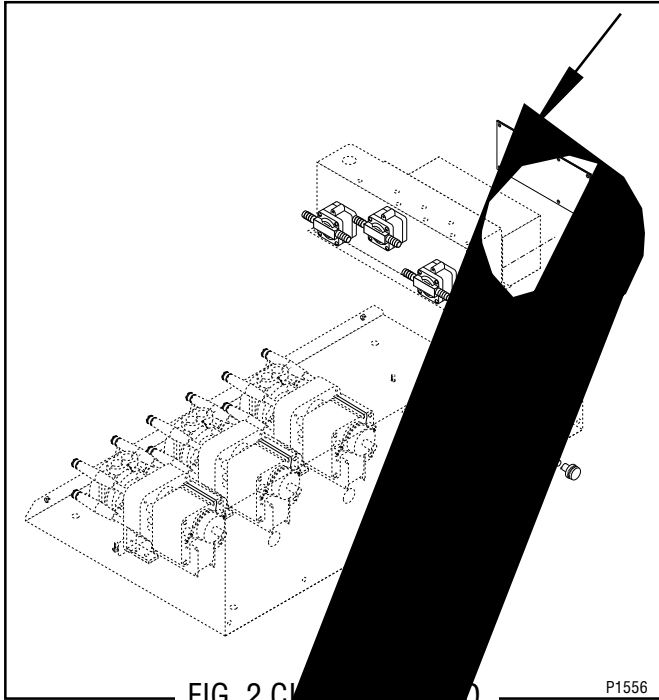

FIG. 1 COMPONENT ACCESS

P1561

CIRCUIT BOARD



Removal and Replacement:

1. Disconnect the ten pin plug from the main wiring harness to the circuit board.
2. Remove the six #4-40 screws and spacers securing the circuit board to the solenoid mounting bracket. Remove circuit board and discard.
3. Install new circuit board using #4-40 screws and spacers to secure the circuit board to the vacuum switch mounting bracket. The spacers must be between the solenoid mounting bracket and the circuit board.
4. Refer to Fig. 3 for circuit board ten pin connector.

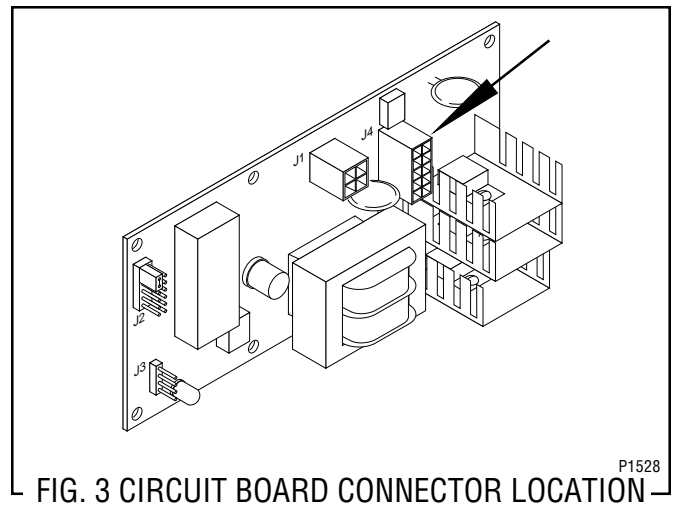

SERVICE

FUSE AND FUSE HOLDER

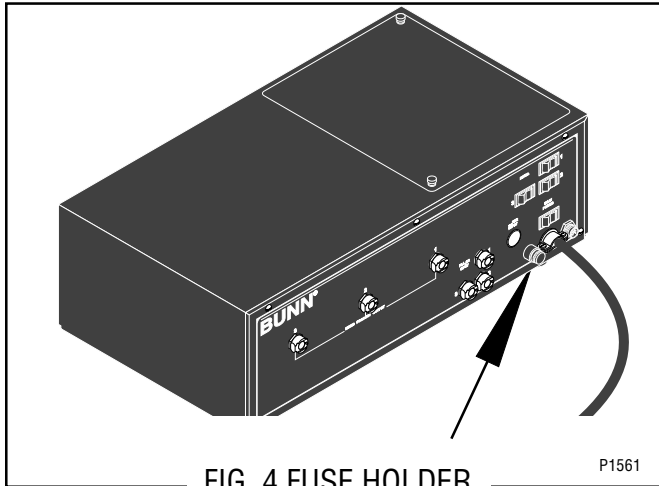

Location:

The fuse holder is located on the lower right front of the autofill box just to the left of the power cord.

Test Procedure:

1. Disconnect the dispenser from the power source.
2. Remove cap and fuse from fuse holder.
3. Remove fuse from the cap.
4. Check for continuity through the fuse.

If continuity is present as described, reinstall the fuse, the fuse is operating properly.

If continuity is not present as described, replace the fuse.

Removal and Replacement:

Fuse:

1. Remove the cap from the fuse holder.
2. Remove fuse from the fuse holder, inspect, if blown discard.
3. Install new 10 amp fuse in the fuse holder.
4. Reinstall fuse holder cap.

Fuse Holder:

1. Disconnect the wires from the rear of the fuse holder.
2. Remove the nut securing the fuse holder to the front of the main mounting panel.
3. Push the fuse holder through the hole in the panel.
4. Install new fuse holder and fuse through the hole in the panel.
5. Secure the fuse holder to the panel.
6. Refer to Fig 5 and reconnect the wires.

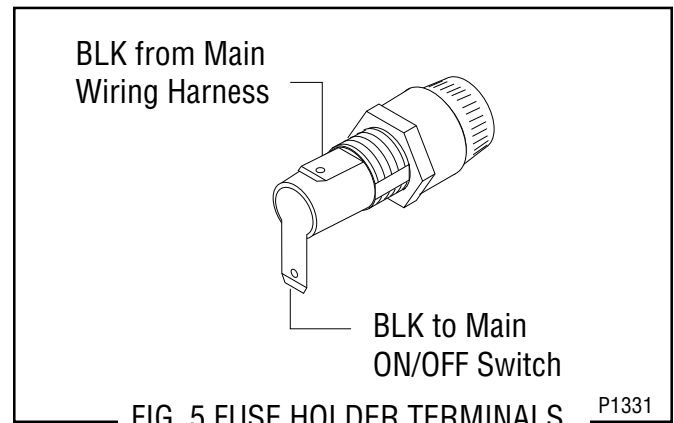

SERVICE (cont.)

MAIN ON/OFF SWITCH

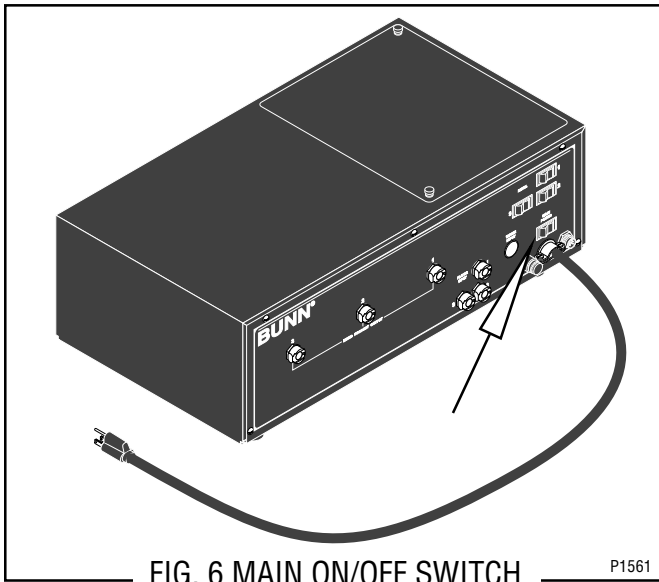

Location:

The main ON/OFF switch is located on the lower right front of the autofill box just above the power cord.

Test Procedure:

1. Disconnect the dispenser from the power source.
2. Disconnect the black wire from the fuse holder to the main ON/OFF switch. Disconnect the white wire from pump #1.
3. Check for voltage across the black wires removed from the switch and the white wire removed from pump #1. Connect the dispenser to the power source. The indication must be:
 - a) 120 volts ac for 2 wire 120 volt models.
 - b) 200 to 240 volts ac for two wire 200 or 240 volt models.
4. Disconnect the dispenser from the power source.

If voltage is present as described, proceed to #5. If voltage is not present as described, refer to the wiring diagrams and check the dispenser wiring harness.

5. Check for continuity across the switch terminals with the switch in the "ON" position. Continuity must not be present when the switch is in the "OFF" position.

If continuity is present as described, reconnect the wires to the switch terminals.

If continuity is not present as described, replace the switch.

Removal and Replacement::

1. Remove the wires from the switch terminals.
2. Compress the clips inside the autofill box and gently push the switch through the opening
3. Push the new switch into the opening and spread the clips to hold switch in the autofill box.
4. Refer to Fig 7 when reconnecting the wires.

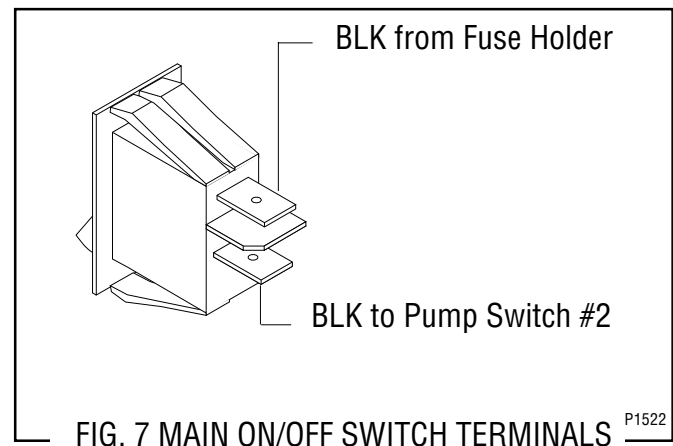

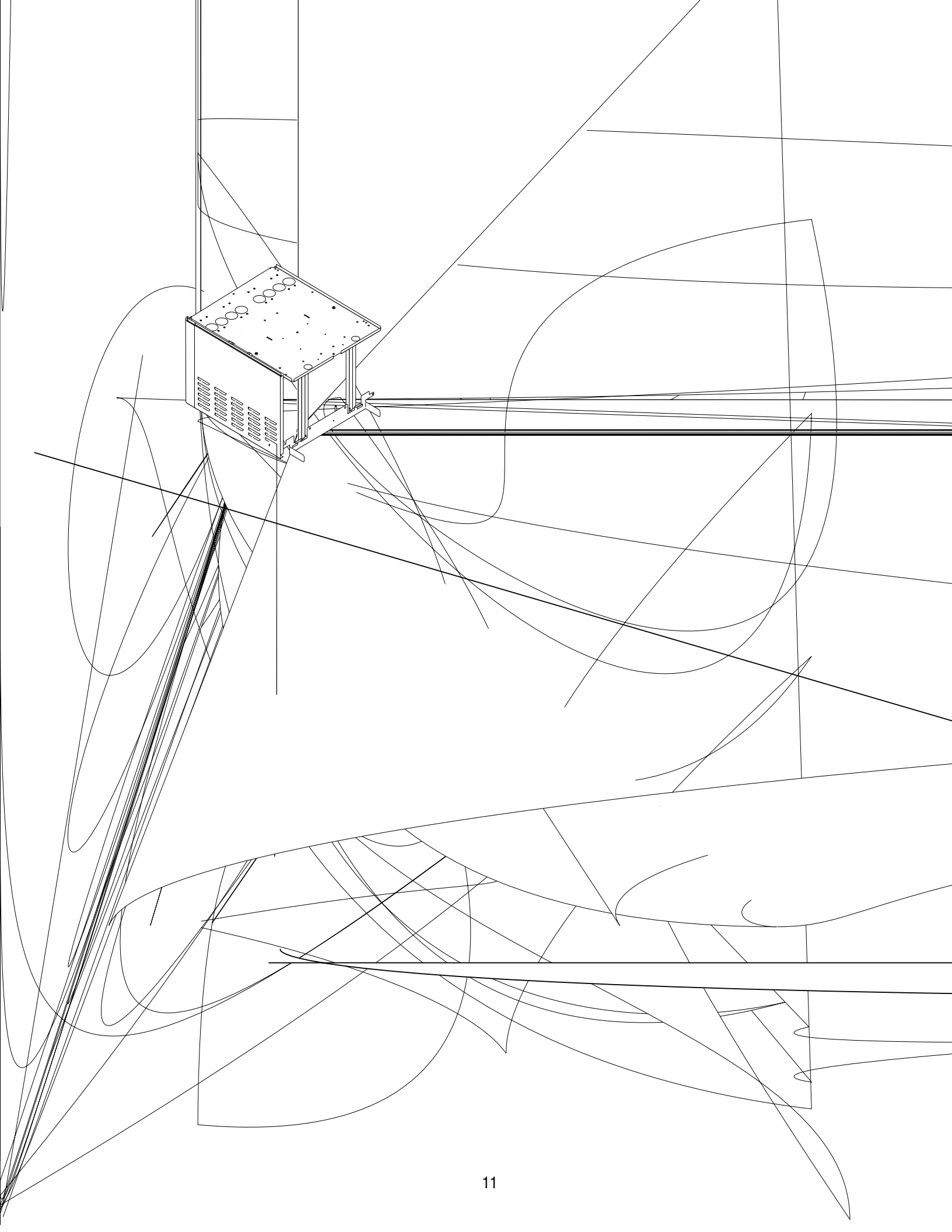

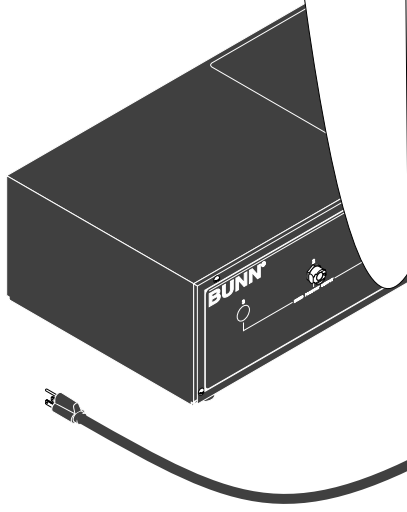

SERVICE (cont.)

VACUUM/SUPPLY PUMP TUBE INSTALLATION

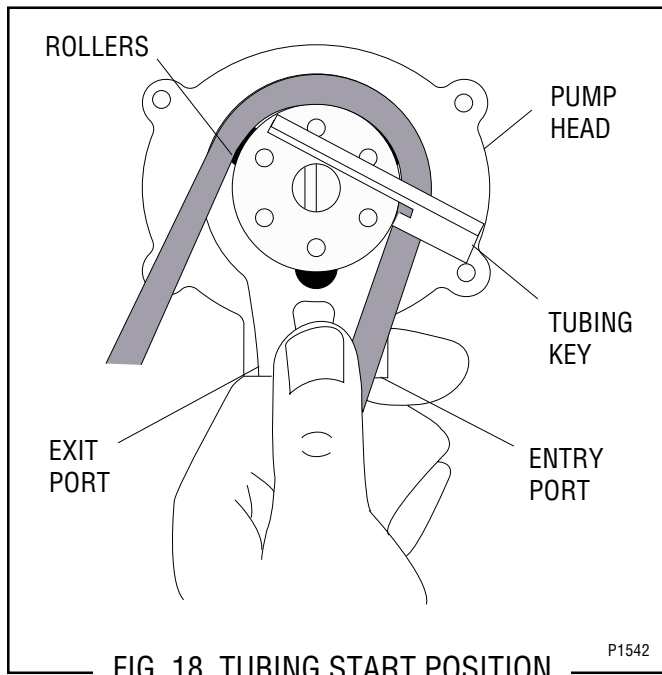

1. Separate the pump head from the pump body. Hold pump head as shown in Fig. 18, with roller in the 2, 6 10 o'clock positions.
2. Wrap tubing around rollers and hold as shown in Fig. 18.
3. Insert the slot of the tubing key (supplied), as shown in Fig. 18 on the rotor so the bottom edge of the key is pressing the tubing into the pump head cavity.
4. Push down and turn the key counterclockwise to guide the tubing deep into the pump head cavity as shown in Fig. 19.
5. Hold the tubing and rotor in the pump head and remove key carefully.
6. Place pump body on the rotor shaft.
7. Squeeze the pump body and pump head together simultaneously until pump body and pump head are touching on all sides. Be careful not to pinch the tubing between the pump body and the pump head.

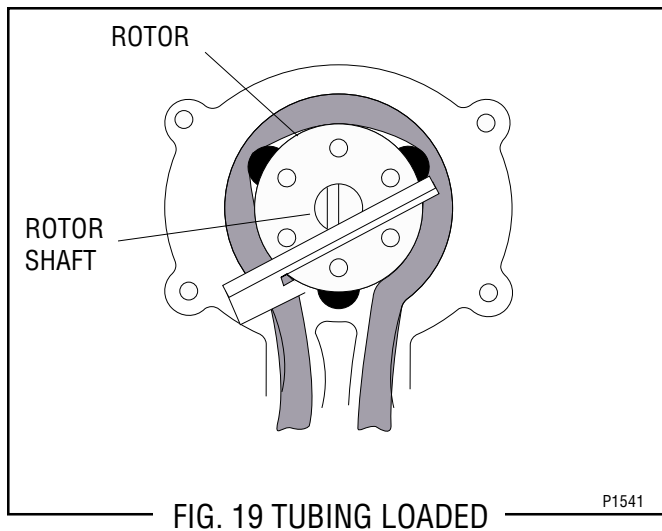

SCHEMATIC WIRING DIAGRAM AFPR-2

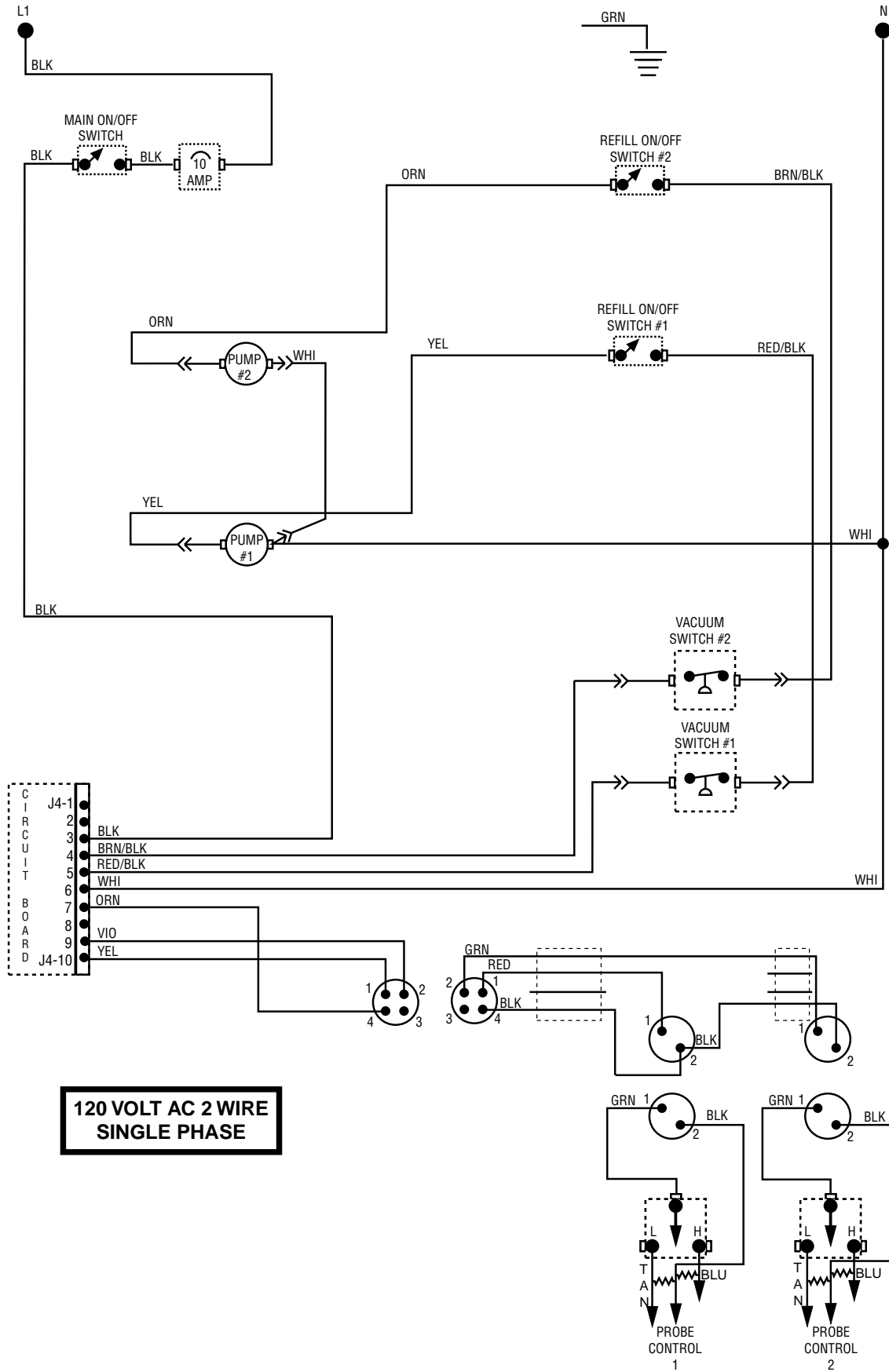

SCHEMATIC WIRING DIAGRAM AFPR-3

