

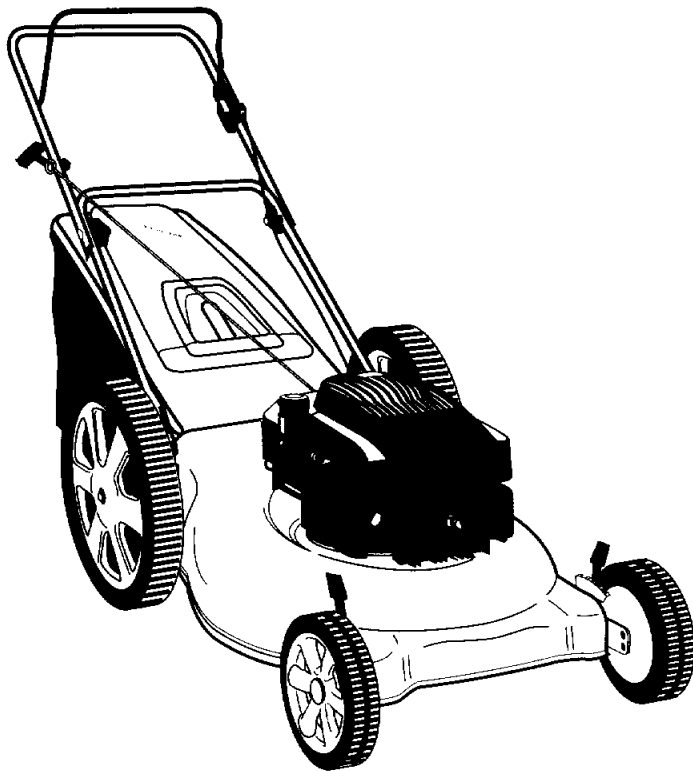

# OWNER'S GUIDE



**MODEL SERIES  
310 - 329  
AND  
510 - 519  
ROTARY MOWER**

Model 518 Shown



## **IMPORTANT: READ SAFETY RULES AND INSTRUCTIONS CAREFULLY**

**Warning:** This unit is equipped with an internal combustion engine and should not be used on or near any unimproved forest-covered, brush-covered or grass-covered land unless the engine's exhaust system is equipped with a spark arrester meeting applicable local or state laws (if any). If a spark arrester is used, it should be maintained in effective working order by the operator. In the State of California the above is required by law (Section 4442 of the California Public Resources Code). Other states may have similar laws. Federal laws apply on federal lands. A spark arrester for the muffler is available through your nearest engine authorized service dealer or contact the service department, P.O. Box 368022 Cleveland, Ohio 44136-9722.

**MTD PRODUCTS INC. P.O. BOX 368022 CLEVELAND, OHIO 44136-9722**

---

## SECTION 1: IMPORTANT SAFE OPERATION PRACTICES



**WARNING:** THIS SYMBOL POINTS OUT IMPORTANT SAFETY INSTRUCTIONS WHICH, IF NOT FOLLOWED, COULD ENDANGER THE PERSONAL SAFETY AND/OR PROPERTY OF YOURSELF AND OTHERS. READ AND FOLLOW ALL INSTRUCTIONS IN THIS MANUAL BEFORE ATTEMPTING TO OPERATE YOUR LAWN MOWER. FAILURE TO COMPLY WITH THESE INSTRUCTIONS MAY RESULT IN PERSONAL INJURY. WHEN YOU SEE THIS SYMBOL, HEED ITS WARNING.



**DANGER:** Your lawn mower was built to be operated according to the rules for safe operation in this manual. As with any type of power equipment, carelessness or error on the part of the operator can result in serious injury. This lawn mower is capable of amputating hands and feet and throwing objects. Failure to observe the following safety instructions could result in serious injury or death.

### 1. GENERAL OPERATION

- Read this owner's guide carefully in its entirety before attempting to assemble this machine. Read, understand, and follow all instructions on the machine and in the manual(s) before operation. Be completely familiar with the controls and the proper use of this machine before operating it. Keep this manual in a safe place for future and regular reference and for ordering replacement parts.
- Your rotary mower is a precision piece of power equipment, not a plaything. Therefore, exercise extreme caution at all times. Your unit has been designed to perform one job: to mow grass. Do not use it for any other purpose.
- Never allow children under 14 years old to operate a power mower. Children 14 years old and over should only operate mower under close parental supervision. Only responsible individuals who are familiar with these rules of safe operation should be allowed to use your mower.
- Keep the area of operation clear of all persons, particularly small children and pets. Stop engine when they are in the vicinity of your mower to help prevent blade contact or thrown object injury. Although the area of operation should be completely cleared of foreign objects, an object may have been overlooked and could be accidentally thrown by the mower in any direction and cause serious personal injury to the operator or any others allowed in the area.
- Thoroughly inspect the area where the equipment is to be used. Remove all stones, sticks, wire, bones, toys and other foreign objects which could be picked up and thrown by the mower in any direction and cause serious personal injury to the operator or any others allowed in the area. Plan your mowing pattern to avoid discharge of material toward roads, sidewalks, bystanders and the like. To help avoid a thrown objects injury, keep children, bystanders and helpers at least 75 feet from the mower while it is in operation.
- **Always** wear safety glasses or safety goggles during operation or while performing an adjustment or repair, to protect eyes from foreign objects that may be thrown from the machine in any direction.
- Wear sturdy, rough-soled work shoes and close-fitting slacks and shirts. Shirts and pants that cover the arms and legs and steel-toed shoes are recommended. Do not wear loose fitting clothes or jewelry. They can be caught in moving parts. Never operate a unit in bare feet, sandals, slippery or light weight (e.g. canvas) shoes.
- Do not put hands or feet near or under rotating parts. Keep clear of discharge opening at all times as the rotating blade can cause injury.
- Many injuries occur as a result of the mower being pulled over the foot during a fall. Do not hang on to the mower if you are falling; release the handle immediately.
- Never pull the mower toward you while you are walking. If you must back the mower away from a wall or obstruction first look down and behind, and then follow these steps:
  - Step back from the mower to fully extend your arms.
  - Be sure you are well balanced with sure footing.
  - Pull the mower back slowly, no more than half way toward you.
  - Repeat these steps as needed.
- Do not operate the mower while under the influence of alcohol or drugs.
- Do not engage the self-propelled mechanism on units so equipped while starting engine.
- The blade control handle is a safety device. Never attempt to bypass its operation. Doing so makes the safety device inoperative and may result in personal injury through contact with the rotating blade. The blade control handle must operate easily in both directions and automatically return to the disengaged position when released.

- Never operate the mower in wet grass. Always be sure of your footing. A slip and fall can cause serious personal injury. Keep a firm hold on the handle and walk, never run. If you feel you are losing your footing, **RELEASE THE BLADE CONTROL HANDLE IMMEDIATELY** and the blade will stop rotating within three seconds.
- Mow only in daylight or good artificial light.
- Stop the blade when crossing gravel drives, walks or roads.
- If the equipment should start to vibrate abnormally, stop the engine and check immediately for the cause. Vibration is generally a warning of trouble.
- Shut the engine off and wait until the blade comes to a complete stop before removing the grass catcher or unclogging the chute. The cutting blade continues to rotate for a few seconds after the engine is shut off. Never place any part of the body in the blade area until you are sure the blade has stopped rotating.
- Never operate mower without proper guards, grass catcher, plates or other safety protective devices in place.
- Muffler and engine become hot and can cause a burn. Do not touch.
- Only use accessories approved for this machine by the manufacturer. Read, understand, and follow all instructions provided with the approved accessory.
- If situations occur which are not covered in this manual, use care and good judgment. Contact your dealer for assistance. Telephone 1-800-800-7310 for the name of your nearest dealer.

## 2. SLOPE OPERATION

For your safety, use the slope gauge included as part of this manual to measure slopes before operating this unit on a sloped or hilly area. If the slope is greater than 15 degrees as shown on the slope gauge, do not operate this unit on that area or serious injury could result.

### DO:

- Mow across the face of slopes; never up and down. Exercise extreme caution when changing direction on slopes.
- Watch for holes, ruts, hidden objects, or bumps. Tall grass can hide obstacles.
- Always be sure of your footing. A slip and fall can cause serious personal injury. If you feel you are losing your balance release the blade control handle immediately and the blade will stop in less than 3 seconds.

### DO NOT:

- Do not mow near drop-offs, ditches or embankments. The operator could lose footing or balance.

- Do not mow slopes greater than 15 degrees as shown on the slope gauge.
- Do not mow on wet grass. Reduced footing could cause slipping.

## 3. CHILDREN

Tragic accidents can occur if the operator is not alert to the presence of children. Children are often attracted to the mower and the mowing activity. Never assume that children will remain where you last saw them.

- Keep children out of the mowing area and under the watchful care of a responsible adult other than the operator.
- Be alert and turn mower off if a child enters the area.
- Before and while moving backwards, look behind and down for small children or other objects.
- Never allow children under age 14 to operate the mower. Children 14 years of age and above should read and understand the operation instructions and safety rules in this manual.
- Use extreme care when approaching blind corners, shrubs, trees, or other objects that may obscure your vision of a child or hazard.

## 4. SERVICE

- Use extreme care in handling gasoline and other fuels. They are extremely flammable and the vapors are explosive.
- Use only an approved gasoline container.
- Never remove gas cap or add fuel while the engine is running. Allow engine to cool at least two minutes before refueling.
- Replace gasoline cap securely and wipe off any spilled gasoline before starting the engine as it may cause a fire or explosion.
- Extinguish all cigarettes, cigars, pipes and other sources of ignition.
- Never refuel machine indoors because flammable vapors will accumulate in the area.
- Never store the machine or fuel container inside where there is an open flame or spark such as a gas water heater, space heater, or furnace.
- Never run an engine inside a closed area.
- To reduce fire hazard, keep mower free of grass, leaves, or other debris build-up. Clean up oil or fuel spillage. Allow mower to cool at least 5 minutes before storing.
- Before cleaning, repairing, or inspecting, make certain the blade and all moving parts have stopped. Disconnect the spark plug wire, and keep the wire away from the spark plug to prevent accidental starting.

- Check the blade and engine mounting bolts at frequent intervals for proper tightness. Also, visually inspect blade for damage (e.g., bent, cracked or worn). Replace with blade which meets original equipment specifications listed in this manual.
- Keep all nuts, bolts, and screws tight to be sure the equipment is in safe working condition.
- Never tamper with safety devices. Check their proper operation regularly.
- After striking a foreign object, stop the engine, remove the wire from the spark plug, and thoroughly inspect the mower for any damage. Repair the damage before starting and operating the mower.

- Never attempt to make a wheel or cutting height adjustment while the engine is running.
- Grass catcher components are subject to wear, damage and deterioration, which could expose moving parts or allow objects to be thrown. For safety protection, frequently check components and replace with manufacturer's recommended parts, when necessary.
- Mower blades are sharp and can cut. Wrap the blade(s) or wear gloves, and use extra caution when servicing them.
- Do not change the engine governor setting or overspeed the engine. Excessive engine speeds are dangerous.



**WARNING - YOUR RESPONSIBILITY:** Restrict the use of this power machine to persons who read, understand and follow the warnings and instructions in this manual and on the machine.



Figure 1 Safety Labels Found On Lawn Mower

## SECTION 2: FIND YOUR MODEL NUMBER

This Owner's Guide is an important part of your new lawn mower. It will help you assemble, prepare and maintain your mower. Please read and understand what it says

Before your start to prepare your mower for its first use, please locate the model plate and copy the information from it in this Owner's Guide. The information on the model plate is very important if you need help from your dealer or the MTD customer support department.

- Every mower has a model plate. You can locate it by standing behind the unit in the operating position and looking down at the cutting deck.
- The model plate will look like figure 2.

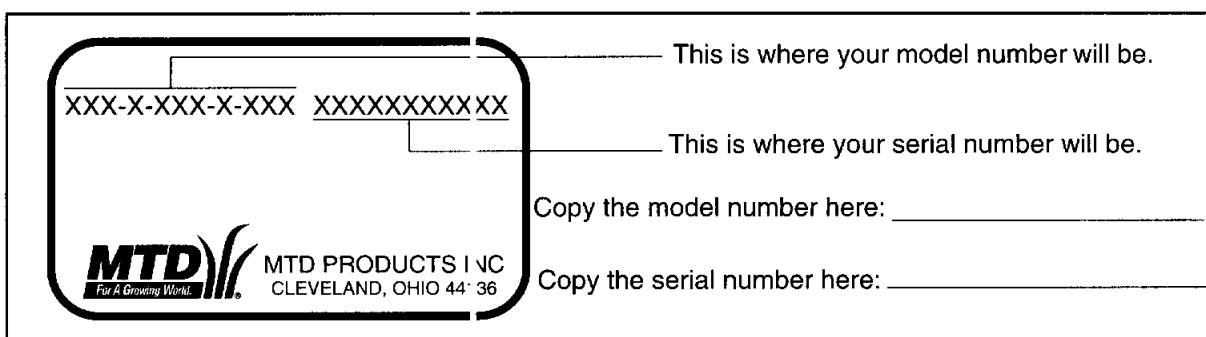
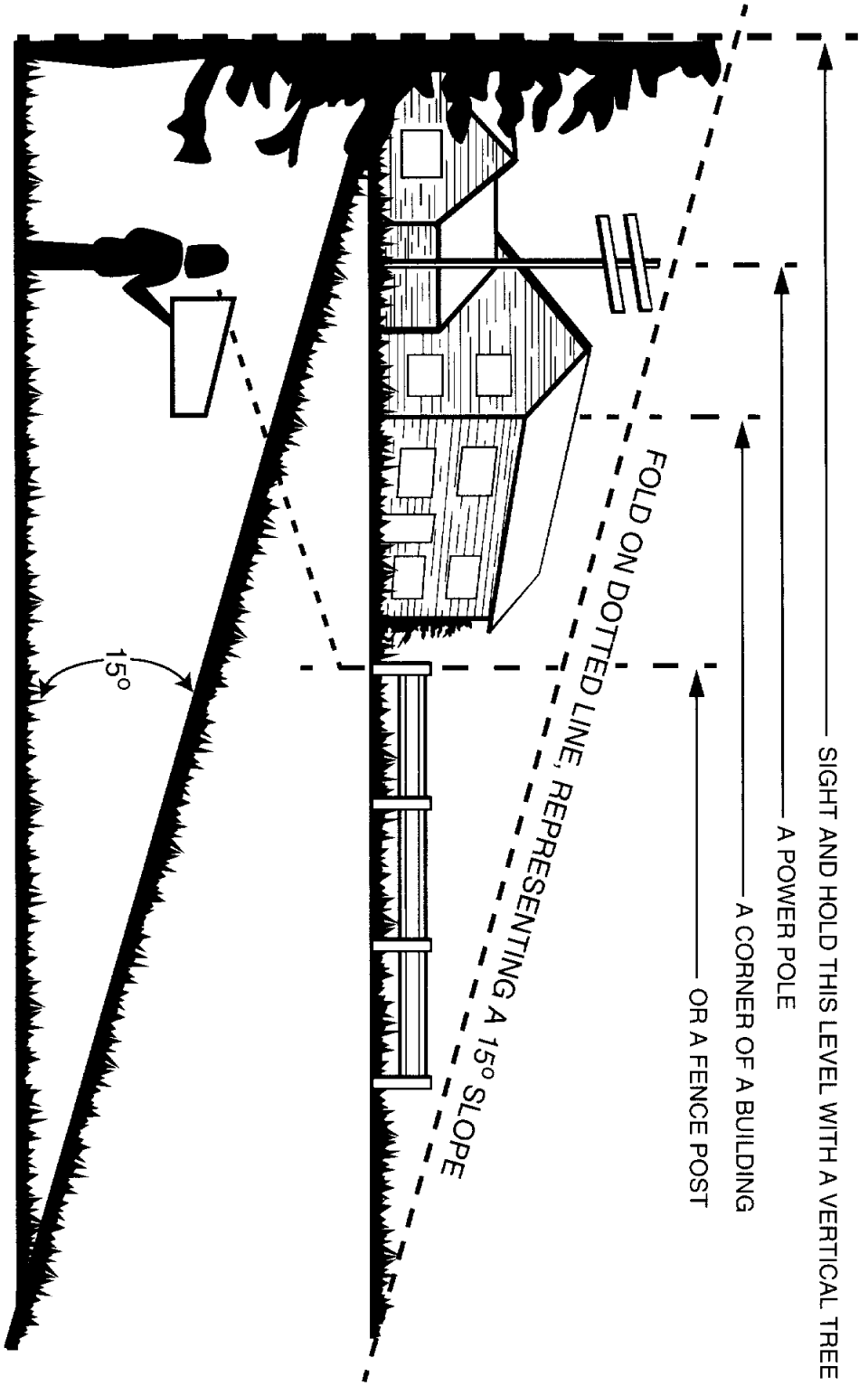

Figure 2

### SECTION 3: SLOPE GAUGE

USE THIS PAGE AS A GUIDE TO DETERMINE SLOPES WHERE YOU MAY NOT OPERATE SAFELY:



**WARNING**

Do not mow on inclines with a slope in excess of 15 degrees (a rise of approximately 2-1/2 feet every 10 feet). A riding mower could overturn and cause serious injury. If operating a walk-behind mower on such a slope, it is extremely difficult to maintain your footing and you could slip, resulting in serious injury. Operate RIDING mowers up and down slopes, never across the face of slopes. Operate WALK-BEHIND mowers across the face of slopes, never up and down slopes.

## SECTION 4: CONTENTS OF HARDWARE PACK

### MODEL 510 - 519 ONLY

Remove this sheet from your owner's guide and lay the hardware from the hardware pack on the illustration for identification purposes. After assembly, keep the Slope Gauge which is on the reverse side of this sheet for future use.

(Hardware pack may contain extra items which are not used on your unit. Part numbers are shown in parentheses.)

### A ATTACHING THE FRONT WHEELS

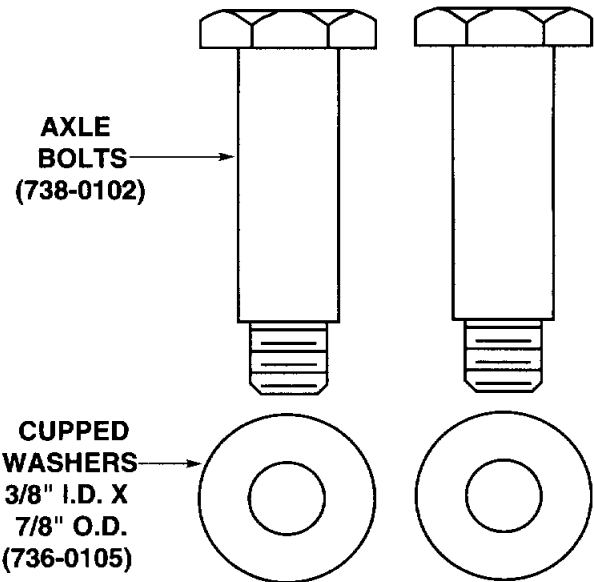

### B ATTACHING THE REAR WHEELS

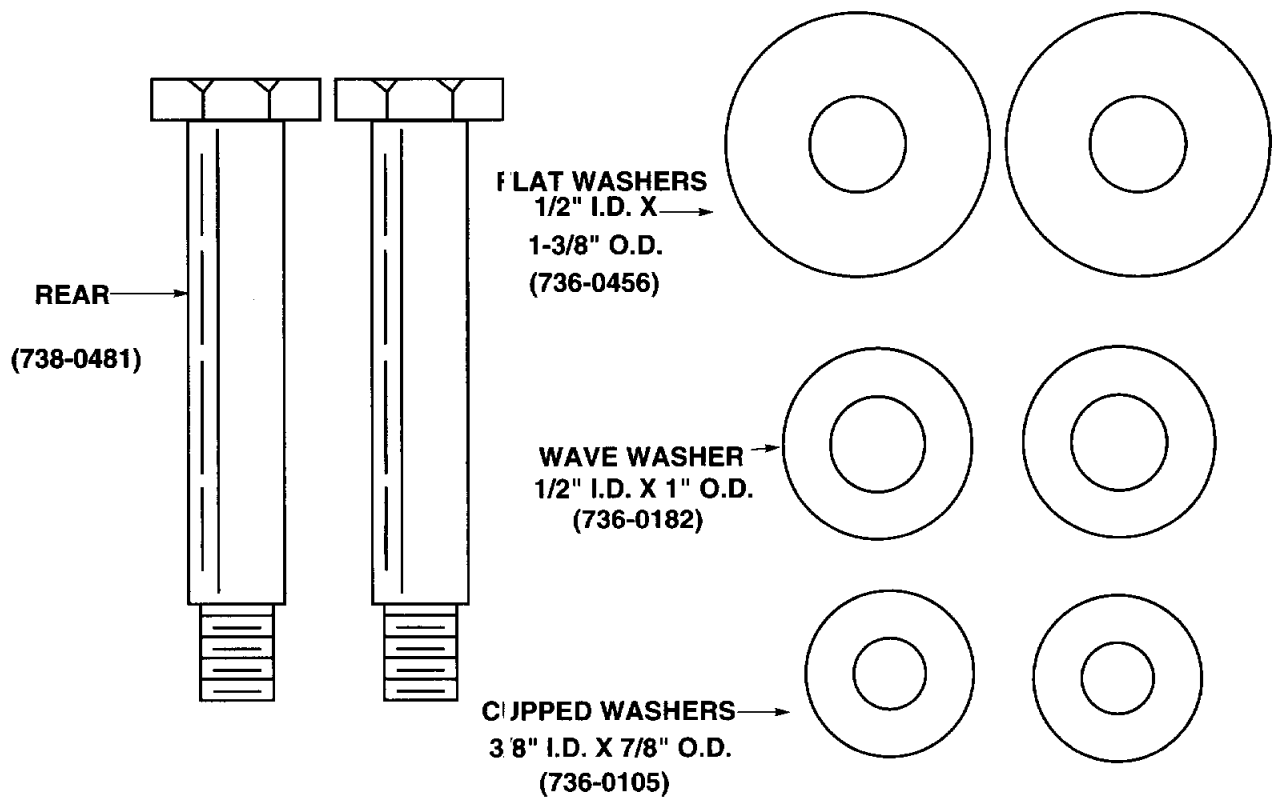

## SECTION 5: SETTING UP MOWER

This guide covers models 310 - 319 push mowers with soft top grass bags, 320 - 329 push mowers with hard top grass bags and models 510 - 518 high wheel push mowers with hard top bags. Much of this guide pertains to both models. However, there are some areas where only one model is covered. Use only the information that is appropriate for your model.

### REMOVING UNIT FROM THE CARTON

- Remove staples, break glue on top flaps, or cut tape at carton end and peel along top flap to open carton.
- Remove loose parts if included with unit (i.e., owner's manual, etc.).
- Cut along dotted lines and lay carton down flat.
- Remove packing material.
- Roll or slide unit out of carton. Check carton thoroughly for loose parts.
- For Model 510-519, remove pages 5 and 6 of this manual listing the hardware pack, and the slope gauge. Lay the contents of the hardware pack on the illustration on page 6 for easy identification.

**Note:** Make sure not to crimp the cables while removing the loose parts or the entire unit from the carton.

### TOOLS REQUIRED

- Pair of Pliers
- 3/4" Wrench or Socket Wrench
- Oil and Fresh Gasoline

### DISCONNECTING THE SPARK PLUG

- Before setting up your lawn mower, disconnect the spark plug wire from the spark plug, and ground it against the engine. See figure 3.

- Attach rubber boot to a bolt on the engine to ground.

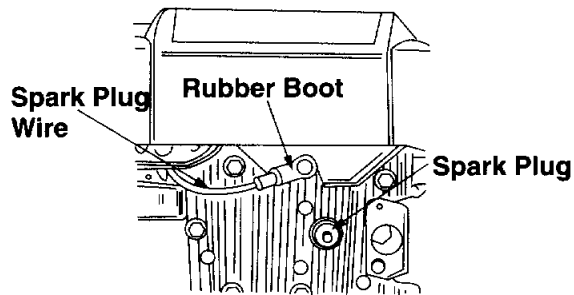

Figure 3

**NOTE:** Reference to right or left hand side of the mower and/or front or behind the mower is observed from the operating position.

**IMPORTANT:** This unit is shipped **without gasoline or oil in the engine**. Be certain to service engine with gasoline and oil before operating your mower.

### ASSEMBLING HANDLE

(Refer to Figure 4.)

- Move the height adjustment levers to the highest cutting position.
- Raise the lower handle from position 1 to position 2 as shown in figure 4. You may have to spread the lower handle slightly to move it around the height adjustment lever. The lower handle should snap into place.

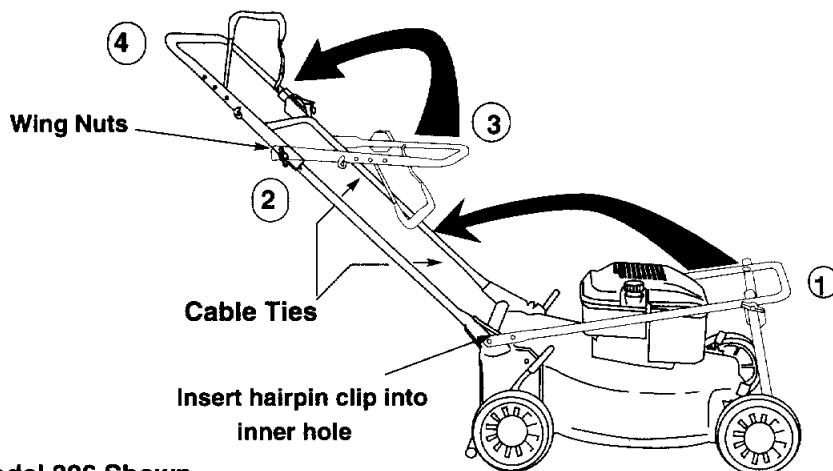

FIGURE 4

**Note:** Make sure to route the cables inside the lower handle. Also do not crimp the cables while lifting the handle up.

For shipping purposes, the lower handles are placed on the unit with the hairpin clip on the outer hole.

- Remove the hairpin clip from the outer hole of the lower handle.
- Using a pair of pliers, pinch lower handle against the handle bracket and insert the hairpin clip into the inner hole in the weld pin. Repeat on other side.
- Raise the upper handle from position 3 to position 4 as shown in figure 4. Tighten the wing nuts which are already on the handle.
- Tighten the cable ties to secure all the cables on the lower handle in place and prevent them from becoming in the way. Refer to figure 4.

### INSTALLING THE WHEELS

(FOR MODELS 510 THRU 519 ONLY)

#### FRONT WHEELS (Hardware A)

- Lift the front of the unit up and block securely.
- Insert front axle bolt through front wheel. Place cupped washer on axle bolt (crowned side against the wheel). Thread axle bolt into top hole in the pivot bar. See figure 5. Tighten securely.
- Assemble the other front wheel in the same manner.
- Remove the block from the front of the unit. Lift the rear of the unit up and block securely.

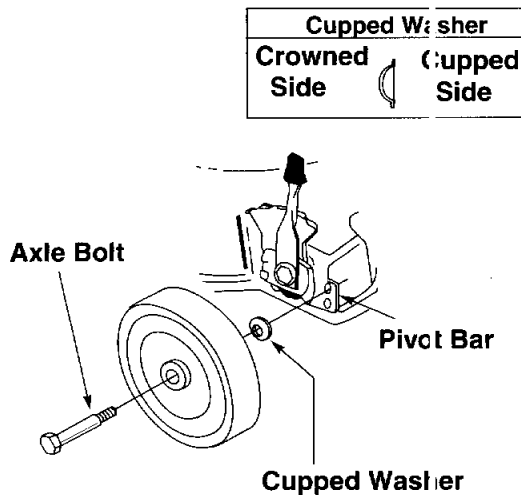

Figure 5

#### REAR WHEELS (Hardware B)

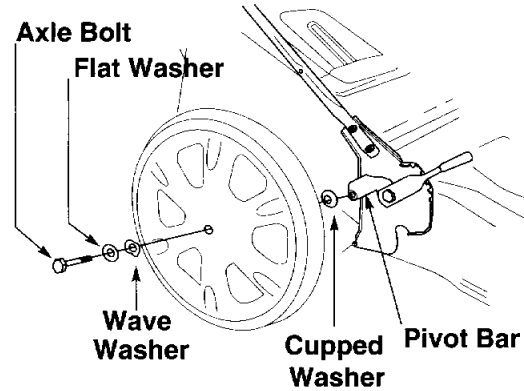
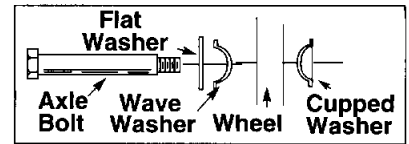

Figure 6

- Assemble the rear wheels as follows. See figure 6.
- Move the wheel height adjusters forward or back so the deck is in the lowest cutting position.
- Place one large flat washer on the axle bolt, then the wave washer as shown in figure 6 inset.
- Insert axle bolt through one rear wheel. Place cupped washer on axle bolt (crowned side of washer goes against the wheel).
- Thread axle bolt into rear hole of pivot bar. Tighten securely.
- Assemble other rear wheel in the same manner. Remove the block from the rear of the unit.

#### ATTACHING THE STARTER ROPE

The rope guide is already attached to the right side of the upper handle of your mower. See figure 7.

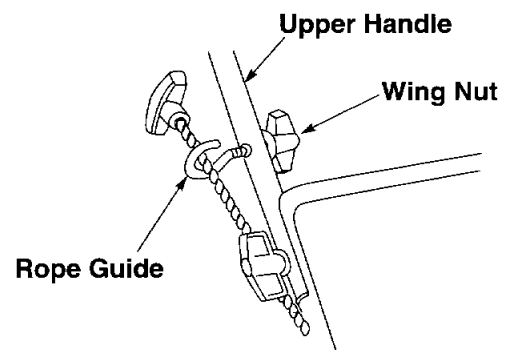

Figure 7



- Loosen the rope guide wing nut.
- With the spark plug wire disconnected and grounded, hold the blade control handle against the upper handle, and pull the starter rope out of the engine.
- Check and make sure that the rope guide faces as shown in figure 7 so that the opening in the rope guide faces up.
- Slip the rope through the rope guide. Tighten the wing nut.

## REMOVE MULCHING KIT

Mulching Plug top and bottom view.

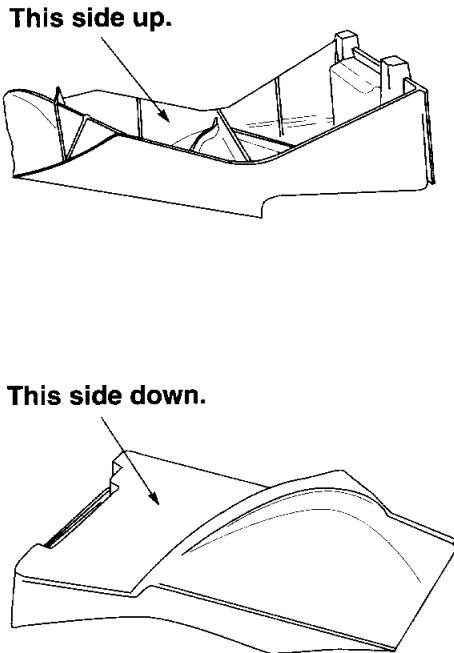

Figure 8

If your mower has been shipped with the mulching kit (model 190-120), it is installed on the mower. If you wish to mow instead of mulch, stand at the left side of the mower, lift the chute door, and grasp the mulching plug. Pull mulching plug out of the mower. See figure 9. Then attach the grass catcher.

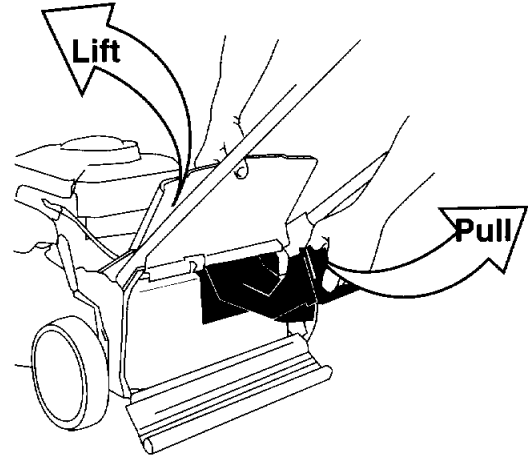

Figure 9

## ATTACHING GRASS CATCHER

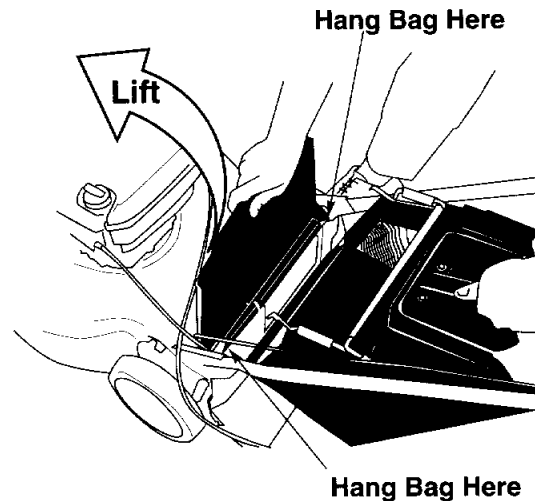

Figure 10

Lift the chute door on the mower. Place hooks on the grass catcher frame over the chute door pivot rod on the back of the unit. See figure 10. Release the chute door.

To remove the grass catcher, lift the chute door on the mower. Lift the grass catcher up, and off of the pivot rod. Release the door.

---

## SECTION 6: CONTROLS

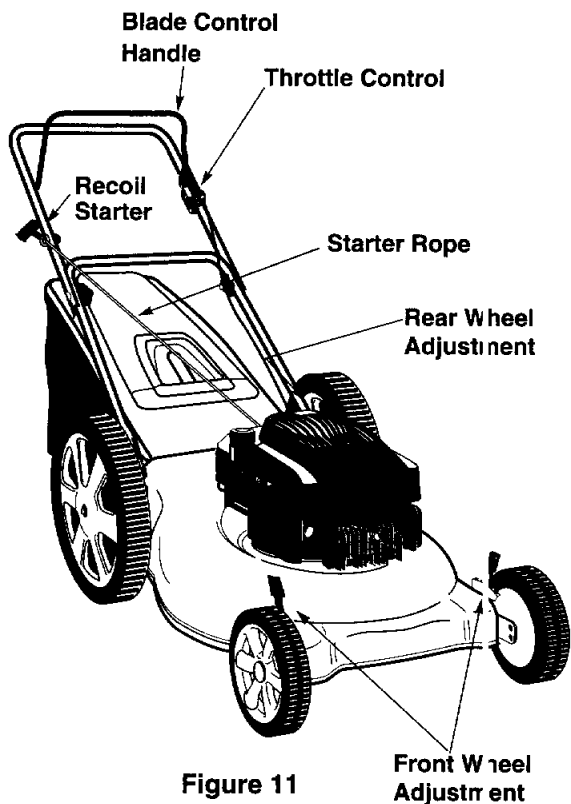

Figure 11

### BLADE CONTROL HANDLE



**WARNING:** This control mechanism is a safety device. Never attempt to bypass its operations.

The blade control handle is located on the upper handle of the mower. See figure 11. The blade control handle must be depressed in order to operate the unit. Release the blade control handle to stop the engine and blade.



**WARNING:** The blade will be rotating whenever the engine is running.

### THROTTLE CONTROL

The throttle control is located on the side of the upper handle. It is used to regulate the engine speed. See figure 11.



**WARNING:** The throttle control cannot be used to stop the engine.

### RECOIL STARTER

The recoil starter handle is attached to the handle. See figure 11. Stand behind the unit in the operating position to start the unit.

### HEIGHT ADJUSTERS

The height adjusters determine the cutting height of the mower. The adjusters are located behind each wheel.

---

## SECTION 7: OPERATION



**WARNING:** Keep hands and feet away from the chute area on cutting deck. The operation of any lawn mower can result in foreign objects being thrown into the eyes, which can result in severe eye damage. Always wear safety glasses or eye shields.

**NOTE:** For shipping purposes models 310 thru 329 are set with the wheels in a low cutting height position. For best results raise the cutting position until it is determined which height is best for your lawn. See cutting height adjustment section.

### GAS AND OIL FILL-UP

Service the engine with gasoline and oil as instructed in the separate engine manual packed with your mower. Read instructions carefully.



**WARNING:** Never fill fuel tank indoors, with engine running or until the engine has been allowed to cool for at least two minutes after running.

### BEFORE STARTING

Attach spark plug wire to spark plug. Make certain the metal cap on the end of the spark plug wire (inside the rubber boot) is fastened securely over the metal tip on the spark plug.

## START ENGINE and ENGAGE BLADE

- Prime engine as instructed in the separate engine manual packed with your unit.
- Move throttle control lever all the way forward.
- Standing behind the unit, depress the blade control handle and hold it against the upper handle. See figure 12.
- Grasp starter handle and pull rope out slowly until engine reaches start of compression cycle (rope will pull slightly harder at this point). Let the rope rewind slowly. Then, pull rope with a rapid, continuous, full arm stroke. Keep a firm grip on starter handle. Return it slowly to the rope guide. See figure 12.
- After engine starts, move throttle control to desired engine speed. (Mower is designed to be operated at full throttle.)

**NOTE:** If any problems are encountered, refer to the Trouble Shooting Guide.

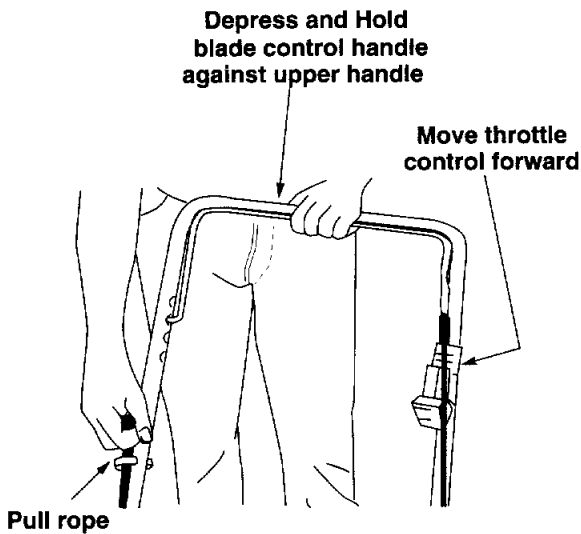

Figure 12

## TO STOP ENGINE AND BLADE

- Release the blade control handle to stop the engine and blade.



**WARNING:** The blade continues to rotate for a few seconds after the engine is shut off.

- Disconnect the spark plug wire and ground it against the engine to prevent accidental starting while equipment is unattended.

## USING YOUR ROTARY MOWER

- Be sure that lawn is clear of stones, sticks, wire, or other objects which could damage lawn mower or engine. Such objects could be accidentally thrown by the mower in any direction and cause serious personal injury to the operator and others.
- For best results, do not cut wet grass because it tends to stick to the underside of the mower, preventing proper discharge of grass clippings, and could cause you to slip and fall. New grass, thick grass or wet grass may require a narrower cut. Blade speed should be adjusted to the condition of the lawn.
- For a healthy lawn, always cut off one-third or less of the total length of the grass. Lawn should be cut in the fall as long as there is growth.
- This mower is designed to be operated at full throttle to give you the best cut and do the most effective job of bagging the cut grass.



**WARNING:** If you strike a foreign object, stop the engine. Remove wire from spark plug, thoroughly inspect the mower for any damage, and repair the damage before restarting and operating the mower. Extensive vibration of the mower during operation is an indication of damage. The unit should be promptly inspected and repaired.

## SECTION 8: ADJUSTMENTS



**WARNING:** Do not at any time make any adjustment to lawn mower without first stopping engine and disconnecting spark plug wire.

### CUTTING HEIGHT ADJUSTMENT

#### Nine position height adjusters.

Each tab and each space between each tab represents one of nine cutting positions available. Refer to illustration 13.

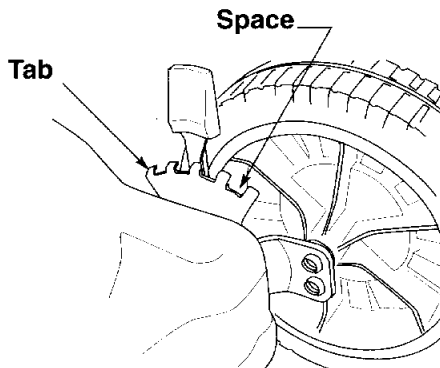

Figure 13

#### Front Wheel Adjustment

An adjusting plate and thumb lever at each front wheel provides cutting height adjustment. Each adjusting plate has nine height positions. Height of cut will be changed when the thumb lever is moved from one position to another. Simply depress the lever towards wheel and move lever forward to raise and back to lower the wheel to the desired position. See figure 14.

#### Rear Wheel Adjustment

The height adjustment handles for the rear wheels are located between the deck and rear wheels. The handles may be placed in one of nine cutting height positions. Simply pull the handle towards the wheel and move wheel and lever assembly to desired position. See figure 15 A / B.

- Model 310/329: Back to lower;  
Forward to raise.
- Model 510/519: Forward to lower;  
Back to raise.

**IMPORTANT:** All wheels must be placed in the same relative position. For rough or uneven lawns, raise the cutting height of your mower.

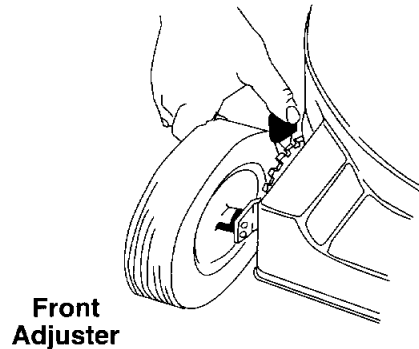

Figure 14

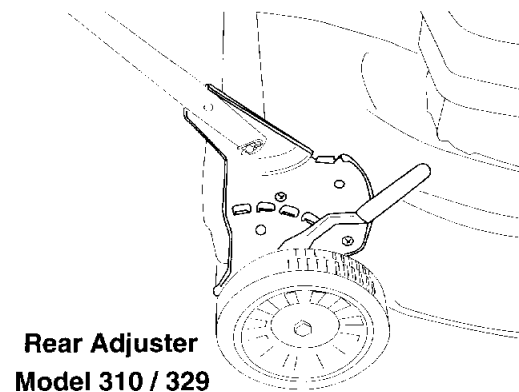

Figure 15 A

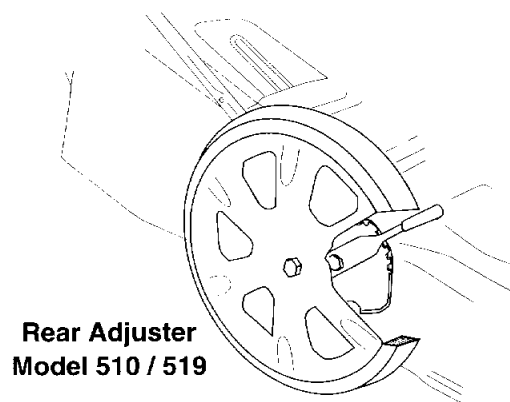

Figure 15 B

## HANDLE HEIGHT ADJUSTMENT

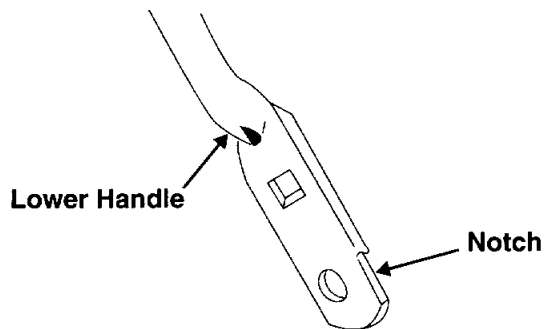

Figure 16

Your mower is shipped with the handle in the higher height position. To lower the handle height, proceed as follows.

- Remove the starter rope from the rope guide.
- Remove the upper handle by removing the hand knobs and carriage bolts. Lay the upper handle out of the way, being careful not to bend or kink the cables.
- Remove the hairpin clips from the weld pins on the handle brackets. Press outward on the legs of the lower handle for self-propelled models. For push models, press inward on the legs of the lower handle. Remove lower handle from the mower.
- Turn the lower handle around so the notch on the bottom of the lower handle is facing forward as shown in figure 16. Reassemble, placing the bottom holes in the handle over the weld pins in the handle mounting bracket.
- Reassemble the upper handle.
- Place the hairpin clips in the inner holes in the weld pins and attach the starter rope as instructed in the Set-Up Instructions.

## THROTTLE CONTROL ADJUSTMENT

If the throttle control requires adjustment or if it has been replaced and need adjustment, proceed as follows:

- Remove the screw shown in figure 17. Remove the cable clamp from the cable.
- Push the throttle control lever on the handle all the way forward as far as it will go, then back it off one "click". Make certain the throttle control lever remains in this position.
- Push the control lever on the engine as far toward the rear of the engine as it will go. Secure the cable in this position with the cable clamp and screw. See figure 17.

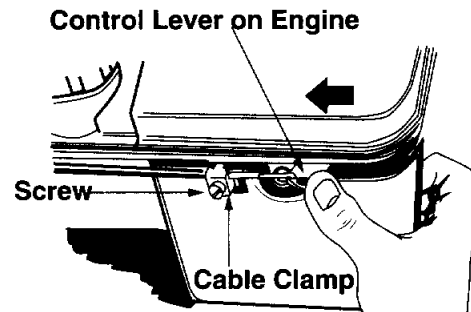

Figure 17

## CARBURETOR ADJUSTMENTS



**WARNING:** If any adjustments are made to the engine while the engine is running (e.g. carburetor), keep clear of all moving parts. Be careful of heated surfaces and muffler. Keep your hands away from these parts.

Minor carburetor adjustments may be required to compensate for differences in fuel, temperature, altitude and load. To adjust carburetor, refer to the separate engine manual packed with your mower.

**NOTE:** A dirty air cleaner will cause an engine to run rough. Be certain air cleaner is clean and attached to the carburetor before adjusting carburetor.

## SECTION 9: MAINTENANCE

### LUBRICATION

(Refer to figure 18.)

**WARNING:** Always stop engine and disconnect spark plug wire before cleaning, lubricating or doing any kind of work on lawn mower.

Lubricate the pivot points on the blade control handle and the brake cable at least once a season with light oil. See figure 18. The blade control must operate freely in both directions.

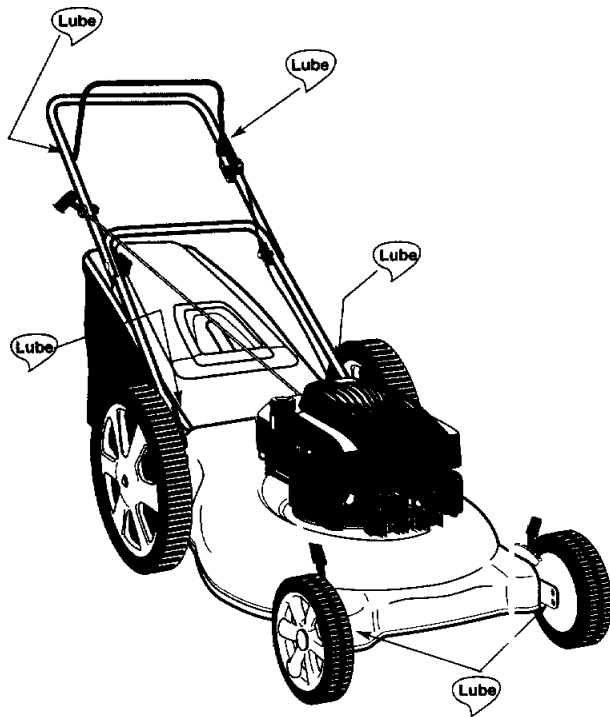

Figure 18

### CHUTE DOOR

Lubricate the torsion spring and pivot point periodically with light oil to prevent any rust or binding. Door must work freely.

### WHEELS

If your lawn mower has ball bearing wheels lubricate at least once a season with light oil (or engine oil). Also, if the wheels are removed for any reason, lubricate the surface of the axle bolt and the inner surface of the wheel.

### ENGINE

Follow engine manual for lubrication instructions.

**WARNING:** Be sure to disconnect and ground the spark plug wire before performing any repairs or maintenance.

**NOTE:** When tipping the unit, empty the fuel tank and keep engine spark plug side up.

### CUTTING BLADE

**WARNING:** Periodically inspect the blade adapter for cracks, especially if you strike a foreign object. Replace when necessary. When removing the cutting blade for sharpening or replacement, protect hands by using heavy gloves or a rag to grasp the cutting blade.

### TO REMOVE BLADE

- Remove the bolt and bell washer which hold the blade and adapter to the engine crankshaft. Remove the blade and adapter from the crankshaft.

### SHARPENING THE BLADE

- Follow the original angle of grind as a guide. Make sure that each cutting edge receives an equal amount of grinding to prevent an unbalanced blade.

### BALANCING THE BLADE

**NOTE:** An unbalanced blade will cause excessive vibration when rotating at high speeds, may cause damage to the mower and could break, causing personal injury.

1. Insert screw driver through hole

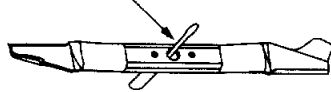

2. Blade should be parallel to ground

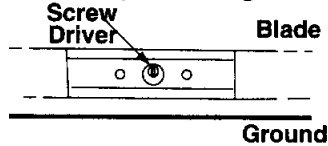

Figure 19

- Test the blade by balancing it on a round shaft screwdriver or a blade balancer. See figure 18. We recommend using the Arnold blade balancer (part # SBB-102) available at your local dealer.
- If the blade is not balanced, remove metal from the heavy side until it balances evenly. We recommend that the blade be always removed from the adapter for the best test of balance.
- Before reassembling the blade and the blade adapter to the unit, lubricate the engine crankshaft and the inner surface of the blade adapter with light oil (or engine oil). Also lubricate the bolt holes, bolts and inner surface of the nuts.

## REPLACING BLADE

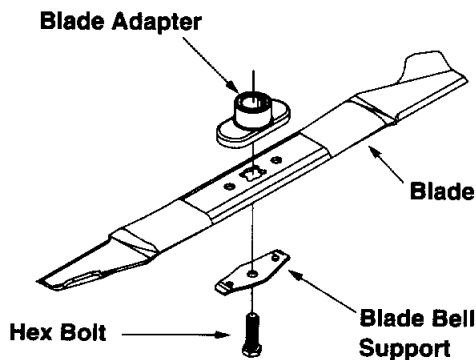

Figure 20

- Install the blade adapter on the crankshaft with the "star" away from the engine. See figure 20.

- Place the blade on the blade adaptor aligning the star in the blade with the star on adaptor. The side of the blade marked with the part number or bottom should be facing towards the ground.
- Place the blade bell support against the blade aligning the tabs of the bell support with the holes of the blade. Insert the hex bolt through the assembly. Refer to figure 20.
- Tighten the hex bolt according to the blade mounting torque mentioned below.

## BLADE MOUNTING TORQUE

Center Bolt: 450 in. lbs. min., 600 in. lbs. max.;

## DECK

Clean the underside of the mower deck after each use to prevent a buildup of grass clippings, leaves, dirt or other matter.

**NOTE:** If this debris is allowed to accumulate, it will invite rust and corrosion, and may cause an uneven discharge of grass clippings at the next cutting.

- Disconnect the spark plug.
- Clean the deck by tilting the mower and scraping with a suitable tool.

## ENGINE

Refer to the separate engine manual for engine maintenance instructions.

- Maintain engine oil as instructed in the separate engine manual provided with your unit. Read and follow instructions on changing oil carefully.
- Service air cleaner every 25 hours under normal conditions. Clean every few hours under extremely dusty conditions. Poor engine performance and flooding usually indicate that the air cleaner should be serviced. To service the air cleaner, refer to the separate engine manual packed with your unit.
- Replace the spark plug at the start of each mowing season. Check engine manual for correct plug type and gap specifications. Clean the spark plug and reset the gap once a season.
- Clean the engine regularly with a cloth or brush.
- Keep the cooling system (blower housing area) clean to permit proper air circulation which is essential to engine performance and life.
- Be certain to remove all grass, dirt and combustible debris from muffler area.

---

## SECTION 10: OFF-SEASON STORAGE

The following steps should be taken to prepare lawn mower for storage.

- Clean and lubricate mower thoroughly as described in the lubrication instructions.
- Refer to separate engine manual for correct engine storage instructions.

- Coat mower's cutting blade with chassis grease to prevent rusting.
- Store mower in a dry, clean area. Do not store next to corrosive materials, such as fertilizer.

**NOTE:** When storing any type of power equipment in an unventilated or metal storage shed, rust-proof the equipment. Lightly coat the equipment with a light oil or silicone, especially cables and all moving parts.



## SECTION 11: TROUBLE SHOOTING

Trouble	Possible Cause	Corrective Action
Engine fails to start	<ol style="list-style-type: none"> <li>1. Blade control handle disengaged.</li> <li>2. Spark plug wire disconnected.</li> <li>3. Throttle control lever not in correct starting position.</li> <li>4. Fuel tank empty, or stale fuel.</li> <li>5. Blocked fuel line (if so equipped).</li> <li>6. Faulty spark plug.</li> <li>7. Engine flooded.</li> </ol>	<ol style="list-style-type: none"> <li>1. Engage blade control handle.</li> <li>2. Connect wire to spark plug.</li> <li>3. Move throttle lever to correct starting position.</li> <li>4. Fill tank with clean, fresh gasoline.</li> <li>5. Clean fuel line.</li> <li>6. Clean, adjust gap or replace.</li> <li>7. Remove spark plug, dry the plug, and crank engine with plug removed and throttle in off position. Replace spark plug, connect wire and resume starting procedures.</li> </ol>
Engine runs erratic	<ol style="list-style-type: none"> <li>1. Unit running in START position.</li> <li>2. Spark plug wire loose.</li> <li>3. Blocked fuel line (if so equipped) or stale fuel.</li> <li>4. Vent in gas cap plugged.</li> <li>5. Water or dirt in fuel system.</li> <li>6. Dirty air cleaner.</li> <li>7. Carburetor out of adjustment.</li> </ol>	<ol style="list-style-type: none"> <li>1. Move throttle lever to FAST position.</li> <li>2. Connect and tighten spark plug wire.</li> <li>3. Clean fuel line; fill tank with clean, fresh gasoline.</li> <li>4. Clear vent.</li> <li>5. Drain fuel tank. Refill with fresh fuel.</li> <li>6. Clean air cleaner.</li> <li>7. Adjust carburetor.</li> </ol>
Engine overheats	<ol style="list-style-type: none"> <li>1. Engine oil level low.</li> <li>2. Air flow restricted.</li> <li>3. Carburetor not adjusted properly.</li> </ol>	<ol style="list-style-type: none"> <li>1. Fill crankcase with proper oil.</li> <li>2. Remove blower housing and clean.</li> <li>3. Adjust carburetor.</li> </ol>
Occasional skip (hesitates) at high speed	<ol style="list-style-type: none"> <li>1. Spark plug gap too close.</li> <li>2. Carburetor idle mixture adjustment improperly set.</li> </ol>	<ol style="list-style-type: none"> <li>1. Adjust gap to .030"</li> <li>2. Adjust carburetor.</li> </ol>
Idles poorly	<ol style="list-style-type: none"> <li>1. Spark plug fouled, faulty or gap too wide.</li> <li>2. Carburetor improperly adjusted.</li> <li>3. Dirty air cleaner.</li> </ol>	<ol style="list-style-type: none"> <li>1. Reset gap to .030" or replace spark plug.</li> <li>2. Adjust carburetor.</li> <li>3. Clean air cleaner.</li> </ol>
Excessive vibration	<ol style="list-style-type: none"> <li>1. Cutting blade loose or unbalanced.</li> <li>2. Bent cutting blade.</li> </ol>	<ol style="list-style-type: none"> <li>1. Tighten blade and adapter. Balance blade.</li> <li>2. Replace blade.</li> </ol>
Mower will not discharge grass	<ol style="list-style-type: none"> <li>1. Engine speed too low.</li> <li>2. Wet grass.</li> <li>3. Excessively high grass.</li> </ol>	<ol style="list-style-type: none"> <li>1. Set throttle between 3/4 and full throttle.</li> <li>2. Do not mow when grass is wet; wait until later to cut.</li> <li>3. Mow once at a high cutting height, then mow again at desired height or make a narrower cutting swath (1/2 width).</li> </ol>
Uneven cut	<ol style="list-style-type: none"> <li>1. Wheels not positioned correctly.</li> <li>2. Dull blade.</li> </ol>	<ol style="list-style-type: none"> <li>1. Place all four wheels in same height position.</li> <li>2. Sharpen or replace blade.</li> </ol>

Refer to separate engine manual packed with our moer for more engine related information.

**Note:** For repairs beyond the minor adjustments listed above, contact your local authorized service dealer or call 1-800-800-7310 for the Customer Support Center.

# SECTION 12: ILLUSTRATED PARTS LIST

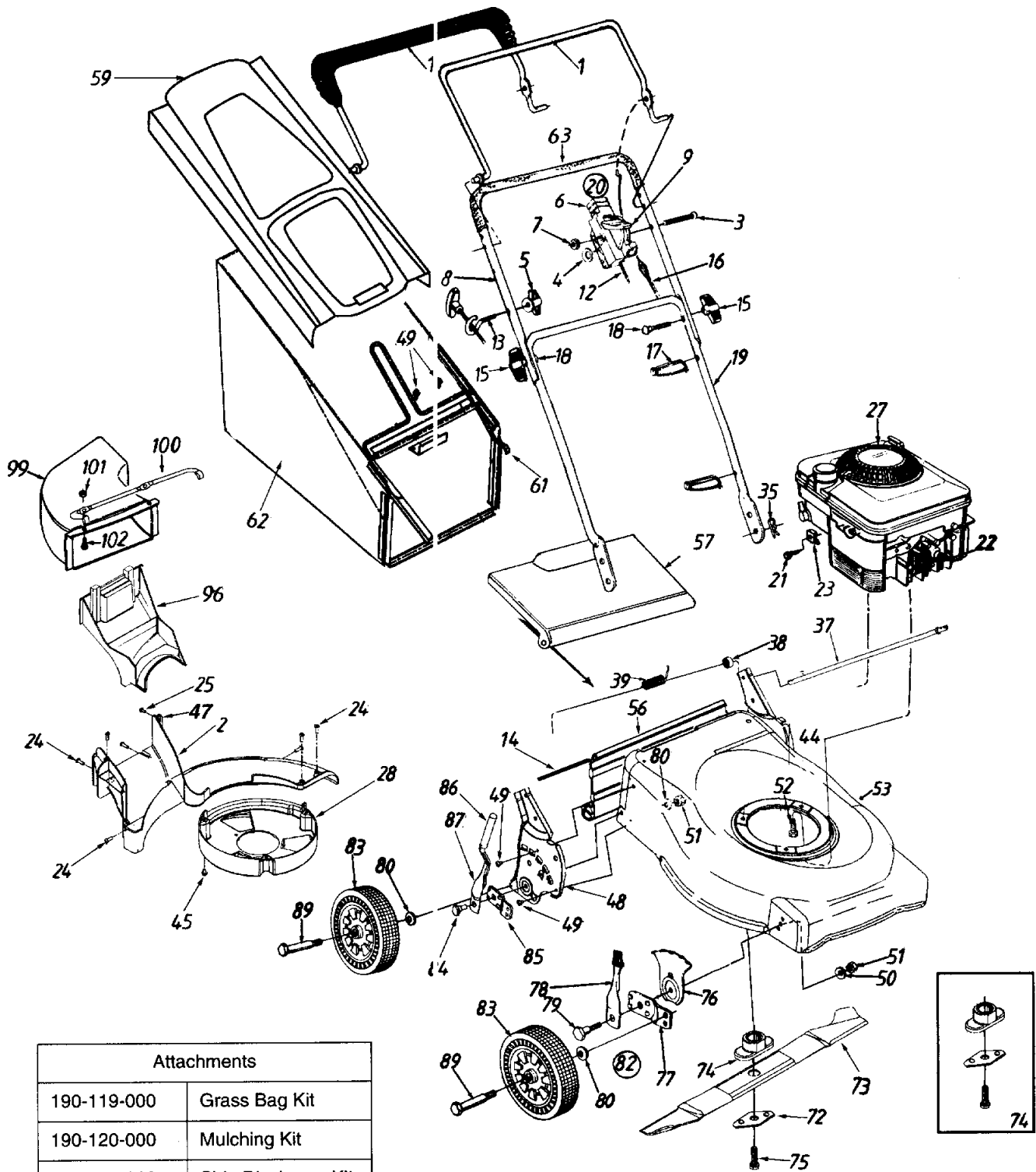

**MODEL NUMBERS 320 - 329**

REF. NO.	PART NO.	DESCRIPTION	REF. NO.	PART NO	DESCRIPTION
1	747-0824	Control Handle Ass'y (Std)	49	710-1348	Screw AB 1/4-20
	647-0004	Control Handle Ass'y (Deluxe)	50	736-0356	Bell-Wash. .39" I.D.
2	731-1639	N Baffle	51	712-0798	Hex Nut 3/8-16 Trd.
3	710-0605	Oval C-Sunk Mach.-Scr.	52	710-0654A	Hex L-Wash. Hd. Scr. 3/8-16x1" Lg.
4	736-0501	Spr.Wash..66" I.D.	53	682-0076	N 21" Deck Ass'y
5	720-0279	Handle Knob 1/4-20 Thd.	56	731-1236	Rear Flap 17.77 Lg.
6	646-0875	Throttle Body	57	782-7599	N Rear Chute Deflector
7	712-0324	Hex L-Nut 1/4-20	58	782-9050	N Brkt. Mtg. Grassbag - Black
8	749-0538B	Upper Handle	59	731-1882	N Hdtop Bag Cover
9	746-0876	Throttle Lever		731-1769	N Hdtop Bag Cover w/MTD Logo
12	746-0843	Throttle Control Wire-55"(328C)		731-1881	N Hdtop Bag Cover w/Flo Ind.
	746-0848	Throttle Control Wire-47" (325A)		731-1221	N Hdtop Bag Cvr w/Flo Ind./MTD Logo
	746-0841	Throttle Control Wire-60" (326F)	61	747-0919	N Catcher Frame
13	710-1205	Rope Guide	62	664-0080	N Grass Bag - Black
14	732-0700	Wire-47"Lg.		664-0079	N Grassbag- Soft top w/MTD Logo
15	720-0276	Hand Knob	63	720-0226	Foam Grip
16	746-0554	Control Cable-40.5" (328C)	72	736-0524A	Blade Bell Support
	746-0555	Control Cable-55" (325A)	73	742-0741	21" Mulching Blade w/Star
	746-0551	Control Cable--43" (326F)	74	753-0609	Blade Adaptor Kit w/Star
17	726-0240	Cable Tie	75	710-1257	Hex Bolt 3/8-24x2.5 Lg.
18	710-1174	Curved Hd. Bolt 5?16-18x2" Lg.	76	15261A	Height Adj. Plate
19	749-0907	Lower Handle	77	15262B	Pivot Bar - Fr.
20	811-00303	Throttle Box Comp. (Incl. Ref. 3, 4,6,7,9)	78	14832	Spring Lever Ass'y w/Knob
21	710-1237	Hex Self-Tap Scr. #10-32 x .62" Lg. (326F)	79	738-0507B	Shld. Bolt .50" Dia x.357"
	710-0871	Hex Sems Scr. #10-32 x .3" Lg. (325A)	80	736-0105	Bell-Wash. .38" I.D. x .88" O.D.
22	735-0639	Spark Plug Boot	82	14578	Height Adj. Ass'y Comp. R.H.
23	751B213146	Cable Clamp (326F)		14579	Height Adj. Ass'y.
	7510007775	Cable Clamp (325A)	83	**	Wheel Ass'y Comp.
24	710-1220	Screw H.L. 12-24	84	738-0507B	Shoulder Screw 1/2" Dia. x .434"
25	710-0351	Screw Mach. B Tapp.	85	15262B	Pivot Bar - Rear
27	--	Engine	86	720-0230	Foam Grip
28	731-1714	N Belt Guard	87	732-0805	N Spring Lever
35	714-0104	Int. Cotter Pin 5/15" Dia.	89	738-0102	Axle Bolt
37	747-0922	N Pivot Rod	96	731-1685	N Mulch Plug
38	750-1068	N Spacer .385 I.D.	99	731-1461	Chute Deflector
39	732-0809	N Torsion Spring L.H.	100	747-0958	N Chute Mounting Rod
44	782-3031	Handle Brkt. Ass'y - L.H..	101	712-0324	Hex L-Nut 1/4-20 tHD.
45	710-0653	Screw, Tap 1/4-20	102	710-0286	Mach. Scr. 1/4-20 x ." Lg.5
47	712-0400	U-Nut	N / I	777-1584	Label - Danger - Cut Finger
48	782-3032	N Handle Brkt. Ass'y- R.H.	N / I	777-3540A	N Label - Comb. Danger / 1-800

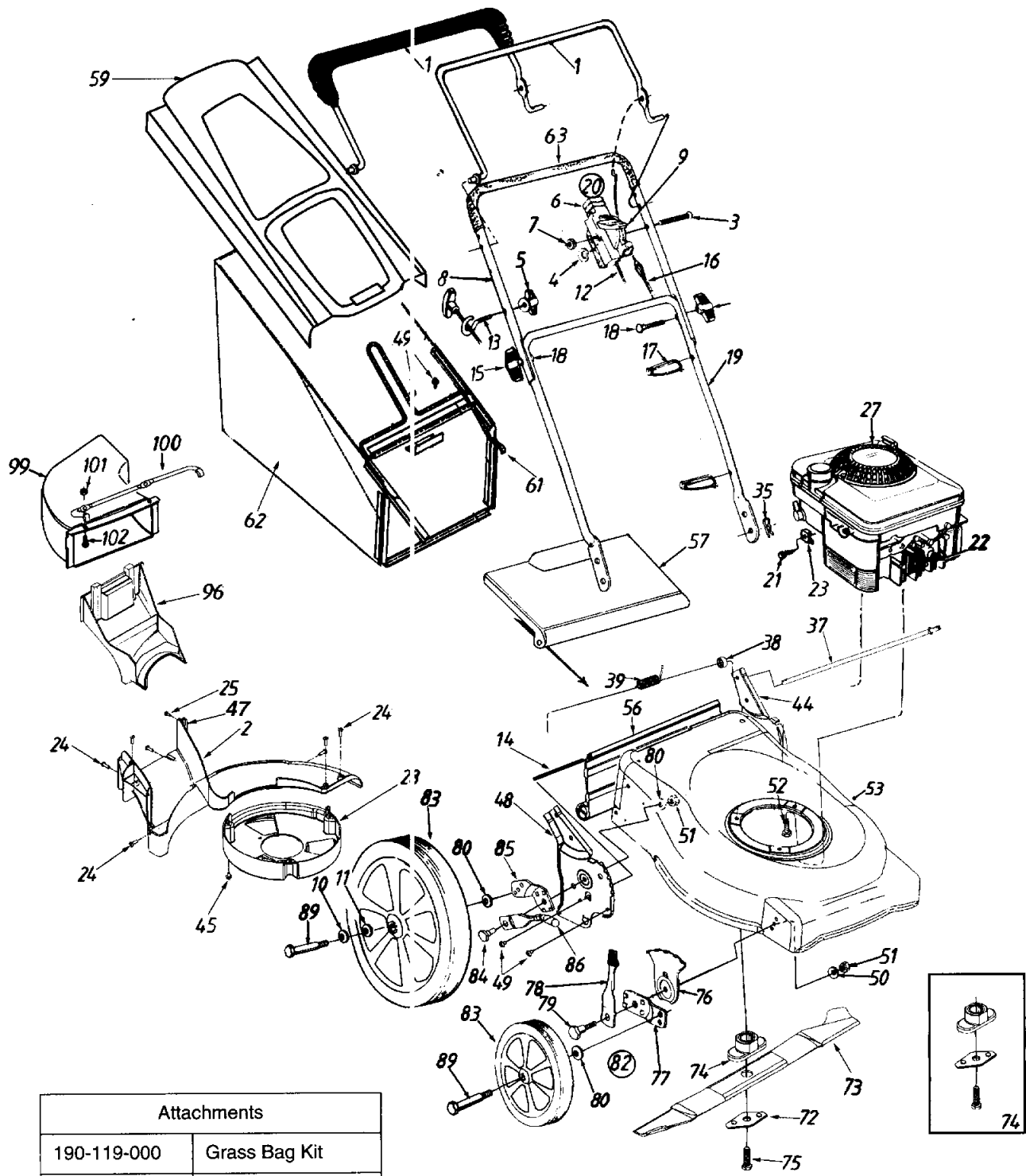

Attachments	
190-119-000	Grass Bag Kit
190-120-000	Mulching Kit
190-137-000	Side Discharge Kit

**MODELS 510 - 519**

REF. NO.	PART NO.		DESCRIPTION	REF. NO.	PART NO		DESCRIPTION
1	747-0824		Control Handle As'y (Std)	51	712-0798		Hex Nut 3/8-16 Trd.
	647-0004		Control Handle Ass'y (Deluxe)	52	710-0654A		Hex L-Wash. Hd. Scr. 3/8-16x1" Lg.
2	731-1639	N	Baffle	53	682-0076	N	21" Deck Ass'y
3	710-0605		Oval C-Sunk Mach.-Scr.	56	731-1236		Rear Flap 17.77 Lg.
4	736-0501		Spr.Wash..66" I.D.	57	782-7599	N	Rear Chute Deflector
5	720-0279		Handle Knob 1/4-20 Thd.	58	782-9050	N	Brkt. Mtg. Grassbag - Black
6	646-0875		Throttle Body	59	731-1882	N	Hdtop Bag Cover
7	712-0324		Hex L-Nut 1/4-20		731-1769	N	Hdtop Bag Cover w/MTD Logo
8	749-0538B		Upper Handle		731-1881	N	Hdtop Bag Cover w/Flo Ind.
9	746-0876		Throttle Lever		731-1221	N	Hdtop Bag Cvr w/Flo Ind. / MTD Logo
10	736-0456		Wash. 1/2" I.D.	61	747-0919	N	Catcher Frame
11	736-0182		Spring Washer	62	664-0080	N	Grass Bag - Black
12	746-0841		Throttle Control Wire-60" (326F)		664-0079	N	Grassbag- Soft top w/MTD Logo
13	710-1205		Rope Guide	63	720-0226		Foam Grip
14	732-0700		Wire-47"Lg.	72	736-0524A		Blade Bell Support
15	720-0276		Hand Knob	73	742-0741		21" Mulching Blade w/Star
16	746-0551		Control Cable 43"	74	753-0609		Blade Adaptor Kit w/Star
17	726-0240		Cable Tie	75	710-1257		Hex Bolt 3/8-24x2.5 Lg.
18	710-1174		Curved Hd. Bolt 5?16-18x2" Lg.	76	15261A		Height Adj. Plate
19	749-0907		Lower Handle	77	15262B		Pivot Bar - Fr.
20	811-00303		Throttle Box Comp. (Incl. Ref. 3, 4,6,7,9)	78	14832		Spring Lover Ass'y w/Knob
21	710-1237		Hex Self-Tap Scr. #10-32 x .62" Lg.	79	738-0507B		Shld. Bolt .50" Dia x.357"
22	735-0639		Spark Plug Boot	80	736-0105		Bell-Wash. .38" I.D. x .88" O.D.
23	751B213146		Cable Clamp	82	14578		Height Adj. Ass'y Comp. R.H.
24	710-1220		Screw H.L. 12-24		14579		Height Adj. Ass'y.
25	710-0351		Screw Mach. B Tapp.	83	**		Wheel Ass'y Comp.
27	--		Engine	84	738-0507B		Shoulder Screw 1/2" Dia. x .434"
28	731-1714	N	Belt Guard	85	17488		Pivot Bar R.H.
35	714-0104		Int. Cotter Pin 5/15" Dia.		17489		Pivot Bar L. H.(Not Shown)
37	747-0922	N	Pivot Rod	86	720-0230		Foam Grip
38	750-1068	N	Spacer .385 I.D.	87	732-0806	N	Spring Lever
39	732-0809	N	Torsion Spring L.H.	89	738-0102		Axle Bolt
44	782-3033		Handle Brkt. Ass'y - L.H..	96	731-1685	N	Mulch Plug
45	710-0653		Screw, Tap 1/4-20	99	731-1461		Chute Deflector
47	712-0400		U-Nut	100	747-0958	N	Chute Mounting Rod
48	782-3034	N	Handle Brkt. Ass'y- R.H.	101	712-0324		Hex L-Nut 1/4-20 tHD.
49	710-1348		Screw AB 1/4-20	102	710-0286		Mach. Scr. 1/4-20 x ." Lg.5
50	736-0356		Bell-Wash. .39" I.D.	N / I	777-1584		Label - Danger - Cut Finger
				N / I	777-3540A	N	Comb. Label - Danger / 1-800

## WHEEL CHART

	Models 510 - 519 Front		Models 510 - 519 Rear		Models 310 - 329 Front and Rear		
Description	Bar Tread	T-Tread	Bar Tread	T-Tread	Bar Tread	T-Tread	S-Tread
Wheels w/o Bearings - Beige	734-1782	-	-	-	-	-	-
Wheels w/o Bearings - Gray	734-1781	-	-	-	734-1781	-	734-1512A
Aero - Gray	734-1841	-	-	-	-	-	-
Wheels w/ Bearings	-	734-1268	734-1842	734-1661	-	734-1268	-
(Brg. Part No. 741-0484)							

## OPTIONAL ENGINE SHROUDS

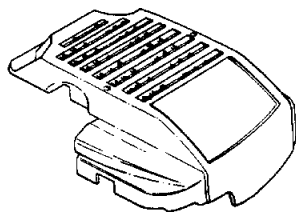
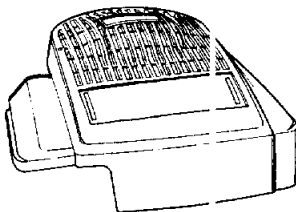
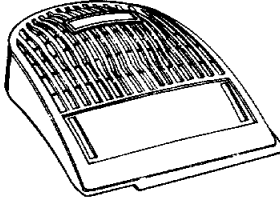
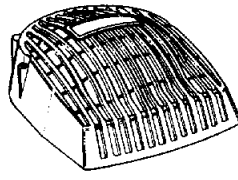
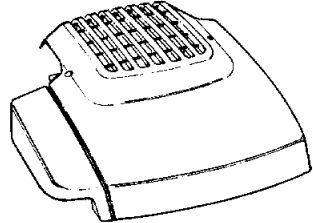
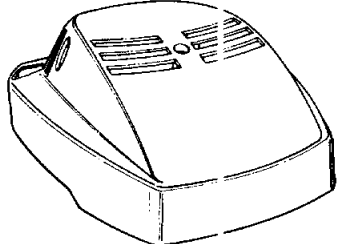
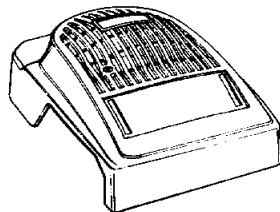
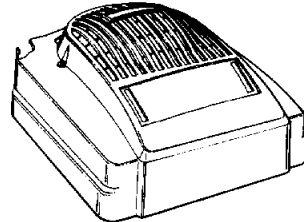
							
Part No. 751B281439 751B281440 751B281443	Color Dark Red Black Bright Red	Part No. 731-1395A 731-1396A 731-1397A	Color Red Black Gray	Part No. 731-1587A 731-1603A 731-1610A	Color Black Yellow Pewter	Part No. 731-1561 731-1612	Color Black Red
Hardware: 710-1256 (Screw)		Hardware: 710-1256 (Screw)		Hardware: 710-1184 (Screw)		Hardware: 7510042823 (Screw)	
							
Part No. 731-1402	Color Yellow	Part No. 7510014208	Color Black	Part No. 731-1585B	Color Black	Part No. 731-1586B	Color Black
Hardware: 710-1258 (Screw)		Hardware: 7510042823 (Screw)		Hardware: 710-1274 (Screw)		Hardware: 7510042823 (Screw)	



**Copy the information from your model plate here!**

□	□	□	□	□	□	□	□	□	□	□	□	□	□	□	□
<b>Model Number</b>															
□	□	□	□	□	□	□	□	□	□	□	□	□	□	□	□
<b>Serial Number</b>															
□	□	□	□	□	□	□	□	□	□	□	□	□	□	□	□

**Please help us  
help you!**

**Call Now!**

**1 (800) 800-7310**

**For Parts, Accessories or Service Information**

**Please have your model number ready when you call**

The only way to insure the performance of your product is to use original equipment parts and accessories. MTD designs and engineers quality parts to exacting specifications. When you substitute, you take a chance on quality, reliability, safety and performance. Use MTD original equipment parts for all of your parts and accessories needs.



**WARNING:** The Engine Exhaust from this product contains chemicals known to the State of California to cause cancer, birth defects or other reproductive harm.