

WHITE[®]

OPERATOR'S MANUAL

LT-145

Model Series
693
HYDROSTATIC
LAWN
TRACTOR

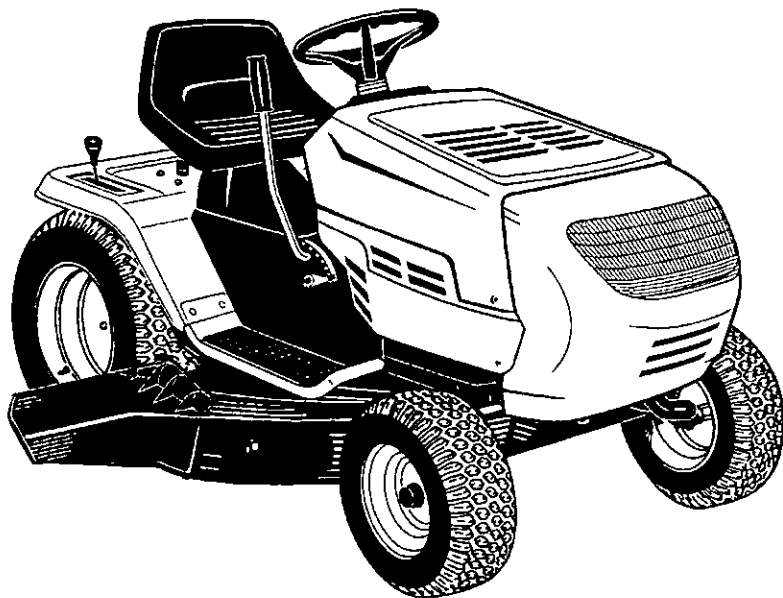

IMPORTANT: READ SAFETY RULES AND INSTRUCTIONS CAREFULLY

Warning: This unit is equipped with an internal combustion engine and should not be used on or near any unimproved forest-covered, brush-covered or grass-covered land unless the engine's exhaust system is equipped with a spark arrester meeting applicable local or state laws (if any). If a spark arrester is used, it should be maintained in effective working order by the operator. In the State of California the above is required by law (Section 4442 of the California Public Resources Code). Other states may have similar laws. Federal laws apply on federal lands. A spark arrester for the muffler is available through your nearest engine authorized service dealer or contact the service department, P.O. Box 361131 Cleveland, Ohio 44136-9722.

WHITE OUTDOOR PRODUCTS COMPANY P.O. BOX 361131 CLEVELAND, OHIO 44136-9722

SECTION 1: FINDING YOUR MODEL NUMBER

This Operator's Manual is an important part of your new lawn tractor. It will help you assemble, prepare and maintain your lawn tractor. Please read and understand what it says.

Before you start to prepare your lawn tractor for its first use, please locate the model plate and copy the information from it in this Operator's Manual. The information on the model plate is very important if you need help from your dealer or the customer support department.

- Every lawn tractor has a model plate. You can locate it by pivoting the seat forward and looking under the seat at the seat pivot bracket. See Figure 1.

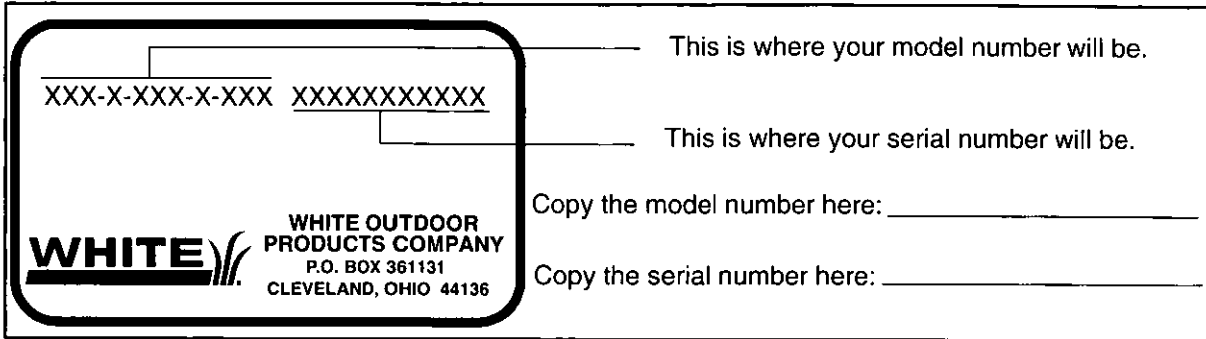

Figure 1

SECTION 2: CALLING WARRANTY SERVICE

If you are having difficulty assembling this product or if you have any question regarding the controls, operation or maintenance of this unit, please call the Customer Dealer Referral Line. You can reach them by calling:

1-800-949-4483

Before calling your local dealer, make sure that you have your model and serial numbers ready. By having the model and serial numbers ready, you help your local dealer give you faster service. To find your unit's model and serial number, see SECTION 2: FINDING YOUR MODEL NUMBER.

SECTION 3: IMPORTANT SAFE OPERATION PRACTICES



WARNING: THIS SYMBOL POINTS OUT IMPORTANT SAFETY INSTRUCTIONS WHICH, IF NOT FOLLOWED, COULD ENDANGER THE PERSONAL SAFETY AND/OR PROPERTY OF YOURSELF AND OTHERS. READ AND FOLLOW ALL INSTRUCTIONS IN THIS MANUAL BEFORE ATTEMPTING TO OPERATE YOUR LAWN MOWER. FAILURE TO COMPLY WITH THESE INSTRUCTIONS MAY RESULT IN PERSONAL INJURY. WHEN YOU SEE THIS SYMBOL, HEED ITS WARNING.



WARNING: The Engine Exhaust from this product contains chemicals known to the State of California to cause cancer, birth defects or other reproductive harm.



DANGER: Your lawn mower was built to be operated according to the rules for safe operation in this manual. As with any type of power equipment, carelessness or error on the part of the operator can result in serious injury. This lawn mower is capable of amputating hands and feet and throwing objects. Failure to observe the following safety instructions could result in serious injury or death.

1. GENERAL OPERATION

- Read, understand, and follow all instructions in the operator's manual and on the machine before starting. Keep this manual in a safe place for future and regular reference and for ordering replacement parts.
- Only allow responsible individuals familiar with the instructions to operate the machine. Know controls and how to stop the machine quickly.
- Do not put hands or feet under cutting deck or near rotating parts.
- Clear the area of objects such as rocks, toys, wire, etc., which could be picked up and thrown by the blade. A small object may have been overlooked and could be accidentally thrown by the mower in any direction and cause injury to you or a bystander. To help avoid a thrown objects injury, keep children, bystanders and helpers at least 75 feet from the mower while it is in operation. Always wear safety glasses or safety goggles during operation or while performing an adjustment or repair, to protect eyes from foreign objects. Stop the blade(s) when crossing gravel drives, walks or roads.
- Be sure the area is clear of other people before mowing. Stop machine if anyone enters the area.
- Never carry passengers.
- Disengage blade(s) before shifting into reverse and backing up. Always look down and behind before and while backing.
- Be aware of the mower and attachment discharge direction and do not point it at anyone. Do not operate the mower without either the entire grass catcher or the chute guard in place.
- Slow down before turning. Operate the machine smoothly. Avoid erratic operation and excessive speed.
- Never leave a running machine unattended. Always turn off blade(s), place transmission in neutral, set park brake, stop engine and remove key before dismounting.
- Turn off blade(s) when not mowing.
- Stop engine and wait until blade(s) comes to a complete stop before (a) removing grass catcher or unclogging chute, or (b) making any repairs, adjusting or removing any grass or debris.
- Mow only in daylight or good artificial light.
- Do not operate the machine while under the influence of alcohol or drugs.
- Watch for traffic when operating near or crossing roadways.
- Use extra care when loading or unloading the machine into a trailer or truck. This unit should not be driven up or down a ramp onto a trailer or truck under power, because the unit could tip over, causing serious personal injury. The unit must be pushed manually on a ramp to load or unload properly.
- Never make a cutting height adjustment while engine is running if operator must dismount to do so.
- Wear sturdy, rough-soled work shoes and close-fitting slacks and shirts. Do not wear loose fitting clothes or jewelry. They can be caught in moving parts. Never operate a unit in bare feet, sandals, or sneakers.
- Check overhead clearance carefully before driving under power lines, wires, bridges or low hanging tree branches, before entering or leaving buildings, or in any other situation where the operator may be struck or pulled from the unit, which could result in serious injury.

- Disengage all attachment clutches, thoroughly depress the brake pedal, and shift into neutral before attempting to start engine.
- Your mower is designed to cut normal residential grass of a height no more than 10". Do not attempt to mow through unusually tall, dry grass (e.g., pasture) or piles of dry leaves. Debris may build up on the mower deck or contact the engine exhaust presenting a potential fire hazard.

2. SLOPE OPERATION

Slopes are a major factor related to loss of control and tip-over accidents which can result in severe injury or death. All slopes require extra caution. If you cannot back up the slope or if you feel uneasy on it, do not mow it.

For your safety, use the slope gauge included as part of this manual to measure slopes before operating this unit on a sloped or hilly area. If the slope is greater than 15° as shown on the slope gauge, do not operate this unit on that area or serious injury could result.

DO:

- Mow up and down slopes, not across.
- Remove obstacles such as rocks, limbs, etc.
- Watch for holes, ruts or bumps. Uneven terrain could overturn the machine. Tall grass can hide obstacles.
- Use slow speed. Choose a low enough gear so that you will not have to stop or shift while on the slope. Always keep machine in gear when going down slopes to take advantage of engine braking action.
- Follow the manufacturer's recommendations for wheel weights or counterweights to improve stability.
- Use extra care with grass catchers or other attachments. These can change the stability of the machine.
- Keep all movement on the slopes slow and gradual. Do not make sudden changes in speed or direction. Rapid engagement or braking could cause the front of the machine to lift and rapidly flip over backwards which could cause serious injury.
- Avoid starting or stopping on a slope. If tires lose traction, disengage the blade(s) and proceed slowly straight down the slope.

DO NOT:

- Do not turn on slopes unless necessary; then, turn slowly and gradually downhill, if possible.
- Do not mow near drop-offs, ditches or embankments. The mower could suddenly turn over if a wheel is over the edge of a cliff or ditch, or if an edge caves in.
- Do not mow on wet grass. Reduced traction could cause sliding.

- Do not try to stabilize the machine by putting your foot on the ground.
- Do not use grass catcher on steep slopes.

3. CHILDREN

Tragic accidents can occur if the operator is not alert to the presence of children. Children are often attracted to the machine and the mowing activity. Never assume that children will remain where you last saw them.

- Keep children out of the mowing area and in watchful care of an adult other than the operator.
- Be alert and turn machine off if children enter the area.
- Before and when backing, look behind and down for small children.
- Never carry children, even with the blades off. They may fall off and be seriously injured or interfere with the safe machine operation.
- Never allow children under 14 years old to operate the machine. Children 14 years and over should only operate machine under close parental supervision and proper instruction.
- Use extra care when approaching blind corners, shrubs, trees or other objects that may obscure your vision of a child or other hazard.
- Remove key when machine is unattended to prevent unauthorized operation.

4. SERVICE

- Use extreme care in handling gasoline and other fuels. They are extremely flammable and the vapors are explosive.
- Use only an approved container.
- Never remove fuel cap or add fuel with the engine running. Allow engine to cool at least two minutes before refueling.
- Replace fuel cap securely and wipe off any spilled fuel before starting the engine as it may cause a fire or explosion.
- Extinguish all cigarettes, cigars, pipes and other sources of ignition.
- Never refuel the machine indoors because fuel vapors will accumulate in the area.
- Never store the fuel container or machine inside where there is an open flame or spark, such as a gas hot water heater, space heater or furnace.
- Never run a machine inside a closed area.
- To reduce fire hazard, keep the machine free of grass, leaves or other debris build-up. Clean up oil or fuel spillage. Allow machine to cool at least 5 minutes before storing.
- Before cleaning, repairing or inspecting, make certain the blade and all moving parts have stopped. Disconnect the spark plug wire, and keep the wire away from the spark plug to prevent accidental starting.

- Check the blade and engine mounting bolts at frequent intervals for proper tightness. Also, visually inspect blade for damage (e.g., excessive wear, bent, cracked). Replace with blade which meets original equipment specifications.
- Keep all nuts, bolts and screws tight to be sure the equipment is in safe working condition.
- Never tamper with safety devices. Check their proper operation regularly. Use all guards as instructed in this manual.
- After striking a foreign object, stop the engine, remove the wire from the spark plug and thoroughly inspect the mower for any damage. Repair the damage before restarting and operating the mower.
- Grass catcher components are subject to wear, damage and deterioration, which could expose moving parts or allow objects to be thrown. For your safety protection, frequently check components and replace with manufacturer's recommended parts when necessary.
- Mower blades are sharp and can cut. Wrap the blade(s) or wear gloves and use extra caution when servicing blade(s).
- Check brake operation frequently. Adjust and service as required.
- Muffler, engine and belt guards become hot during operation and can cause a burn. Allow to cool down before touching.
- Do not change the engine governor settings or overspeed the engine. Excessive engine speeds are dangerous.
- Observe proper disposal laws and regulations. Improper disposal of fluids and materials can harm the environment and the ecology.
- Prior to disposal, determine the proper method to dispose of waste from your local Environmental Protection Agency. Recycling centers are established to properly dispose of materials in an environmentally safe fashion.
- Use proper containers when draining fluids. Do not use food or beverage containers that may mislead someone into drinking from them. Properly dispose of the containers immediately following the draining of fluids.
- DO NOT pour oil or other fluids into the ground, down a drain or into a stream, pond, lake or other body of water. Observe Environmental Protection Agency regulations when disposing of oil, fuel, coolant, brake fluid, filters, batteries, tires and other harmful waste.



WARNING - YOUR RESPONSIBILITY: Restrict the use of this power machine to persons who read, understand and follow the warnings and instructions in this manual and on the machine.

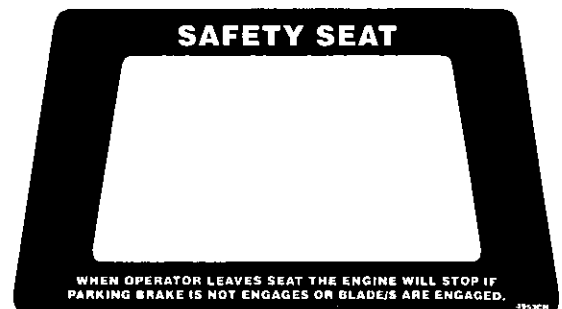
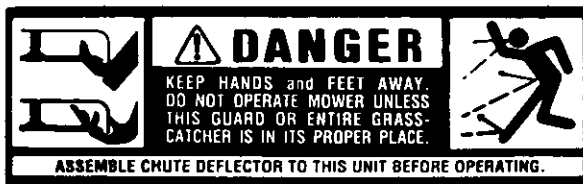
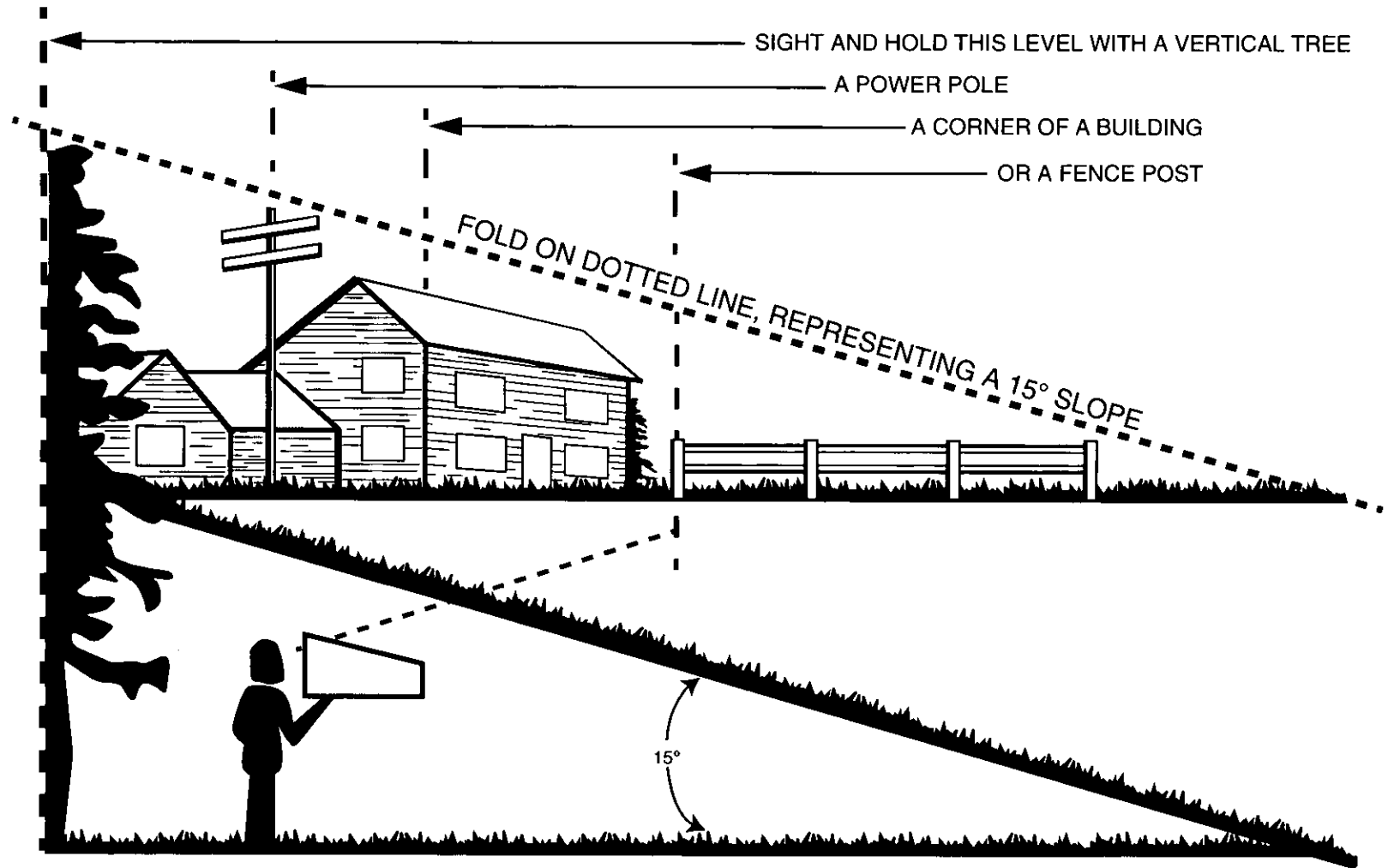

Figure 2 Safety labels found on your unit

USE THIS PAGE AS A GUIDE TO DETERMINE SLOPES WHERE YOU MAY NOT OPERATE SAFELY.



Slope Gauge



WARNING

Do not mow on inclines with a slope in excess of 15 degrees (a rise of approximately 2-1/2 feet every 10 feet). A riding mower could overturn and cause serious injury. If operating a walk-behind mower on such a slope, it is extremely difficult to maintain your footing and you could slip, resulting in serious injury.

Operate RIDING mowers up and down slopes, never across the face of slopes.

Operate WALK-BEHIND mowers across the face of slopes, never up and down slopes.

SECTION 4: UNPACKING

TO REMOVE UNIT FROM CRATE

1. Remove all screws from the top of the crate using a 1/4" hex head socket or a flat blade screwdriver.
 2. To remove ends, grasp top board on the end, and pull towards you in a downward motion. (A hammer may be helpful).
 3. Set panel aside to avoid tire punctures.
 4. Repeat procedure for each side of the crate.
 5. Remove and discard plastic bag which covers unit.
6. Loose parts (may include the owner's guide, steering wheel, optional oil drain sleeve, battery fluid, chute deflector, etc.) are in a box wrapped in plastic. Carefully cut and remove the plastic wrap. Remove the loose parts.
 7. Make certain parking brake and hydrostatic transmission relief valve are released and unit is in neutral. See the controls section of this manual for the location of the parking brake release and the hydrostatic relief valve. Raise the deck and push the unit off the skid.

SECTION 5: ASSEMBLY INSTRUCTIONS

IMPORTANT: After assembly, service engine with gasoline, and check oil level as instructed in the separate engine manual packed with your unit.

NOTE: Reference to right or left hand side of the unit is observed from the driver's seat, facing forward.

TOOLS REQUIRED FOR ASSEMBLY

- (1) 1/4" socket wrench or flat blade screwdriver
- (1) 1/2" wrench or socket wrench
- (1) 9/16" wrench or socket wrench
- (2) 7/16" wrenches or socket wrenches

BATTERY INFORMATION



WARNING

- A. Battery acid must be handled with great care as contact with it can burn and blister the skin. It is also advisable to wear protective clothing (goggles, rubber gloves and apron) when working with it.
- B. Should battery acid accidentally splatter into the eyes or onto the face, rinse the affected area immediately with clean cold water. If there is any further discomfort, seek prompt medical attention.
- C. If acid spills on clothing, first dilute it with clean water, then neutralize with a solution of ammonia/water or baking soda/water.
- D. Since battery acid is corrosive, do not pour it into any sink or drain. Before discarding empty electrolyte containers, rinse them with a neutralizing solution.

- E. NEVER connect or disconnect charger clips to battery while charger is turned on as it can cause sparks.
- F. Keep all lighted materials (cigarettes, matches, lighters) away from the battery as the hydrogen gas generated during charging can be combustible.
- G. As a further precaution, only charge the battery in a well-ventilated area.

***Always shield eyes, protect skin and clothing when working near batteries.**



DANGER

Battery contains sulfuric acid. Refer to warning at right. Antidote: EXTERNAL—Flush with water. INTERNAL—Drink large quantities of water or milk. Follow with milk of magnesia, beaten eggs or vegetable oil. Call physician immediately. EYES: Flush with cool water for at least 15 minutes, then get prompt medical attention.

Since batteries produce explosive gases, keep all lighted materials (cigarettes, lighters, matches, etc.) away. Be sure to charge battery only in well-ventilated areas. Make certain venting path of battery drain tube (if equipped) is always open.

**KEEP BATTERIES
OUT OF THE REACH OF CHILDREN!**

BATTERY IDENTIFICATION

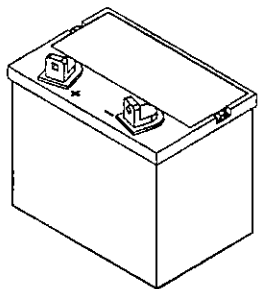

Type "A"

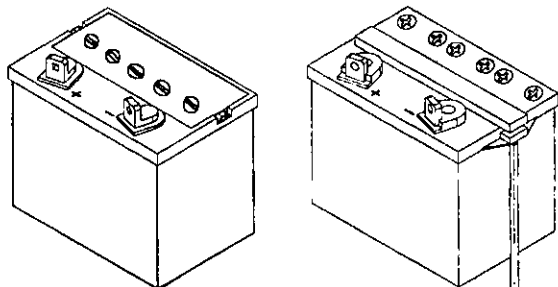

Type "B"

Compare the battery in your lawn tractor (located under the seat) with the illustration above. Type "A" batteries are activated and are ready to use. Type "B" batteries must be filled with battery fluid (acid) and charged before they are put into service. Follow the instructions which apply to the battery in your lawn tractor.

ACTVATING AND CHARGING THE BATTERY

(TYPE "B" BATTERY ONLY)

Do not activate battery (fill with battery acid) until battery is actually placed in service. Be certain to read previous battery warnings before activating the battery.

1. Pivot the seat pivot bracket forward. Unhook the strap which secures the battery (hook is on rear frame, under fender). Disconnect the positive cable from the positive terminal. Save the hardware for reassembly.
2. Remove the battery from the lawn tractor, paying attention to how the battery is placed in the unit, and how the drain tube (attached to the battery) is routed.
3. Activate the battery as instructed in the "Quick Start" brochure included with the battery fluid. **Read instructions carefully.**

NOTE: You can continue assembling the lawn tractor while battery is standing for 30 minutes (after filling with acid), and later while you are charging the battery.

IMPORTANT: To obtain the maximum life from your battery, it **MUST BE CHARGED** prior to initial use.

CHARGE THE BATTERY after the 30 minute standing period. Battery P/N 725-1705D—Charge at 2-3 amps for one hour. Battery P/N 725-1707D, 725-0453G, and 725-1750—Charge at 6 amps for one hour.

NOTE: If you charge the battery at a lower AMP rate, use a hydrometer to make sure the battery is completely charged. The hydrometer should read 1.260 minimum at an electrolyte temperature of 60-110°F. **DO NOT CHARGE AT MORE THAN 6 AMPS.**

ATTACHING THE STEERING WHEEL

1. The hardware for attaching the steering wheel has been packed inside the steering wheel. Carefully pry off the steering wheel cap and remove the hardware.
2. Remove the steering bellow from the lift lever on the right hand side of lawn tractor. Place steering bellow over the steering shaft extending through the dash. See Figure 3.

NOTE: If the openings on each end of the steering bellow are two different sizes, the smaller end goes down against the dash of the lawn tractor.

3. **With the wheels of the tractor pointing straight forward**, place the steering wheel over the steering shaft, positioning steering wheel as desired.
4. Place the washer with the cupped side down over the steering shaft. Secure with hex lock bolt.
5. Place the steering wheel cap over the center of the steering wheel and seat it with your hand.

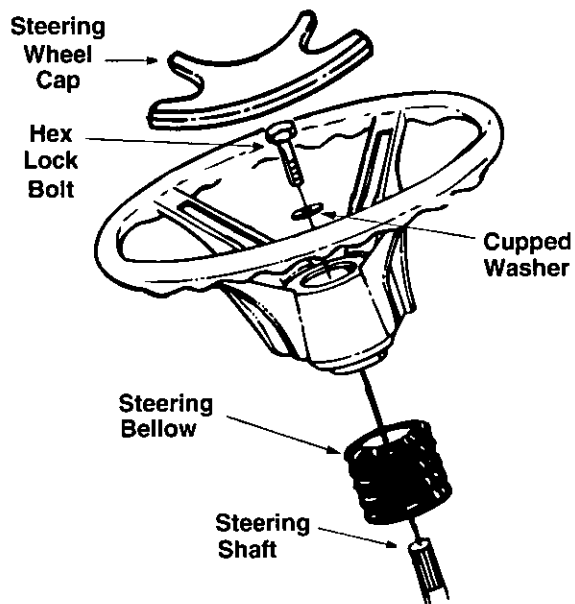

Figure 3

ATTACHING THE SEAT

Pull out tab on seat stop and hold open while sliding seat out of seat pivot bracket. See Figure 4. Turn the seat around and line up plastic seat spacers with the slots in seat pivot bracket. Slide seat in until front seat spacer engages the seat stop. See Figure 5. To adjust the seat refer to the adjustment section in this manual.

NOTE: If your seat was shipped in a box, line up plastic seat spacers with the slots in seat pivot bracket and slide seat in until front seat spacer engages seat stop.

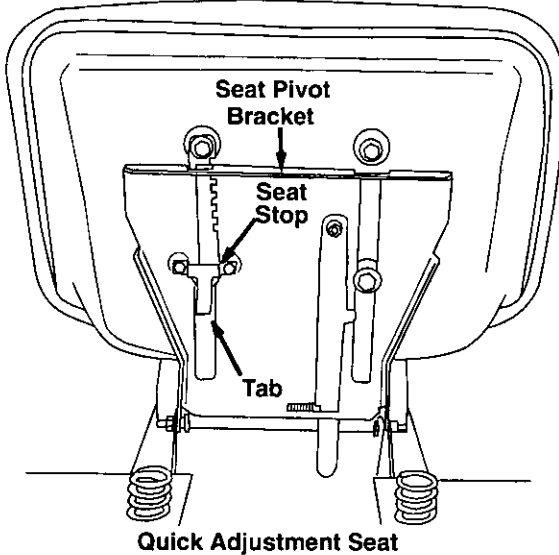

Figure 4

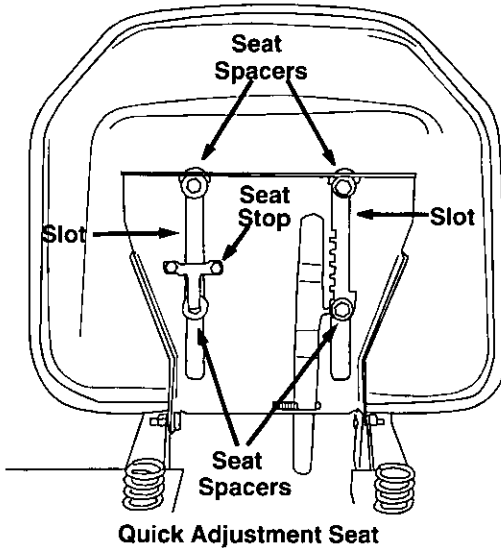

Figure 5



WARNING: Before operating your unit, stand behind quick adjustment seat and pull back on seat, making sure seat is engaged in seat stop.

ATTACHING THE CHUTE DEFLECTOR

The chute deflector must be attached to the right side of the deck so that it covers the chute opening.

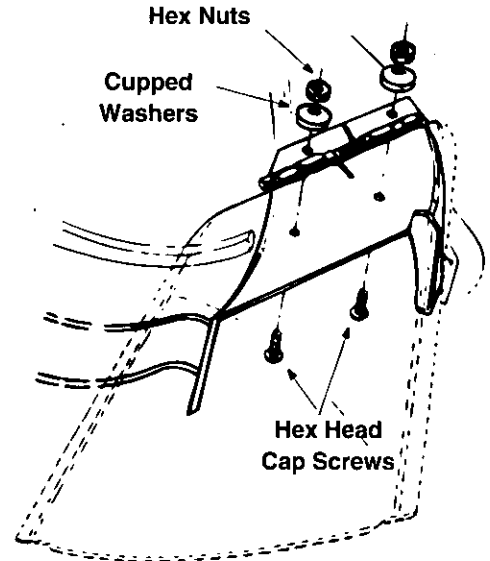

Figure 6



WARNING: Do not operate your unit unless the chute deflector has been properly installed.

1. Make certain deck is raised to its highest position (lift lever pulled all the way back).
2. Remove the hex head cap screws, cupped washers and hex nuts which are attached to the deck next to the chute opening.
3. Place the chute deflector in position as shown in Figure 6. Secure with hardware just removed. Cupped sides of washers go against the chute deflector.

TIRE PRESSURE

The tires on your unit may be over-inflated for shipping purposes. Reduce the tire pressure before operating the unit. Recommended operating tire pressure is approximately 10 p.s.i. Check sidewall of tire for maximum p.s.i.



WARNING: Maximum tire pressure under any circumstances is 30 p.s.i. Equal tire pressure should be maintained on all tires.

LEVELING THE DECK

With unit on hard, level surface, measure the distance from the bottom edge of the center of the left side of deck to the ground. Measure the same distance on the center of the right side of the deck, just

behind the chute area. Or, place the blades in a straight line, and measure the distance from the outside edge of the blade tips to the ground.

If adjustment is needed, proceed as follows.

1. Remove the hairpin clip and flat washer from the bottom of the adjustable lift link on the left side of the deck. See Figure 7. (Hairpin clip and flat washer are on the inside of the lift link.)
2. Pull the adjustable lift link out of the deck hanger channel. See Figure 7. Turn the adjustable lift link up or down as necessary to level the deck. Usually only one or two turns are needed.
3. Insert the end of the adjustable lift link into the hole in the deck hanger channel. Recheck the adjustment. Readjust if necessary.
4. When deck is level, secure end of adjustable lift link with flat washer and hairpin clip.

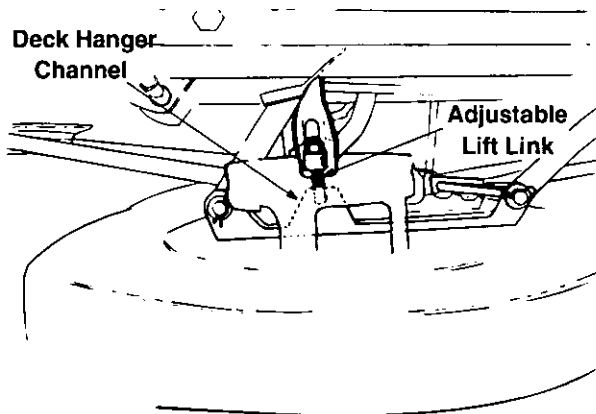

Figure 7

INSTALLING THE BATTERY (TYPE "A")

NOTE: If battery is put into service after date shown on top of battery, charge for minimum of 1 hour at 6-10 amps.

1. Lift the seat.
2. Remove the plastic cover from the negative terminal.
3. Remove the hex bolt and nut from the negative (black) cable. Attach negative cable to the negative terminal with this bolt and nut.

INSTALLING THE BATTERY (TYPE "B")

1. Lift the seat.
2. Make certain both the negative (black) cable and the positive (red) cable are routed up through the battery compartment as shown in Figure 8.
3. Replace the battery into the battery compartment in the same position as it was before (positive terminal is toward the front of the unit).

4. Attach the positive (red) cable to the positive terminal of the battery. Secure with hex bolt and nut previously removed. Slide rubber boot down over the positive terminal.
5. Remove the hex bolt and nut from the negative (black) cable. Attach negative cable to the negative terminal with this bolt and nut.
6. Secure battery by hooking battery strap into slot in rear frame, under the fender. See Figure 9.
7. Insert the drain tube (if equipped) through the hole in the transaxle reinforcement bracket located on the **right** side of the unit. See Figure 9. Be certain drain tube is routed away from the wheel rim.
8. Trim excess end of drain tube if necessary (about 4" should extend past the bracket or cable tie).

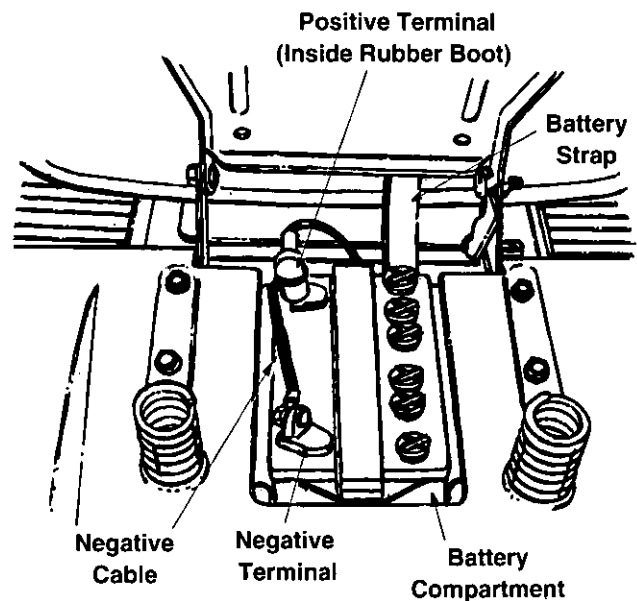

Figure 8

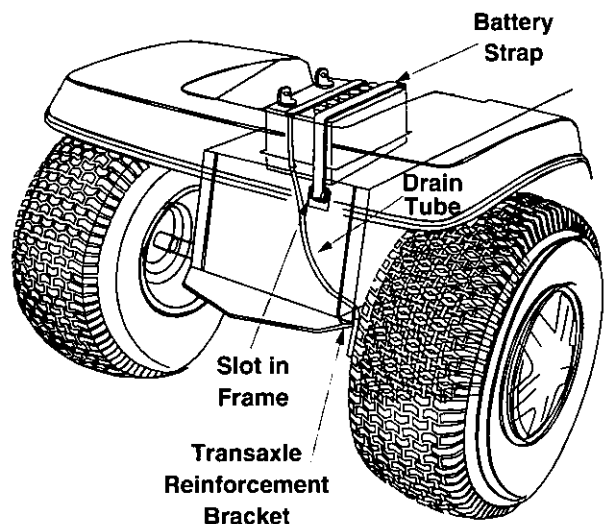

Figure 9

SECTION 6: CONTROLS

IGNITION SWITCH

The ignition switch is located on the dashboard. Turn the key to the START position to start the engine. When the engine is running, leave the key in the ON position. To stop the engine, turn the key to the OFF position. See Figure 10.



WARNING: Remove key from the tractor when tractor is not in use to prevent accidental starting.

THROTTLE CONTROL

The throttle control is located on the dashboard and is used to regulate the engine speed. To get maximum efficiency from cutting, the throttle should be in the fast position when operating the mower. See Figure 10.

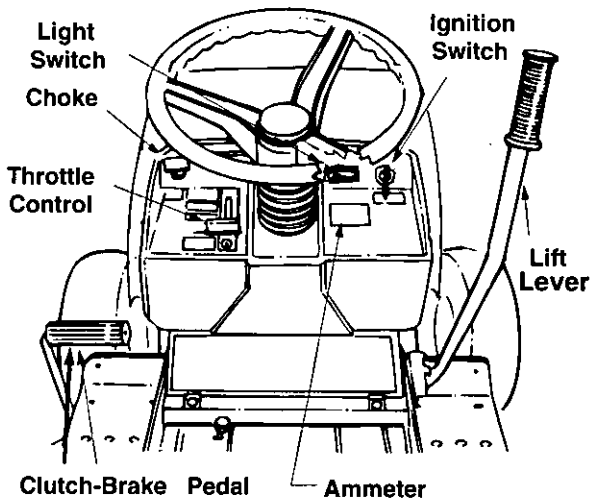

Figure 10

CHOKE CONTROL

The choke control is located on the left side of the dashboard and is operated manually. Details for the choke operation are covered in the separate engine manual packed with your unit. See Figure 10.

LIGHT SWITCH

The head lamps are operated by pushing the light switch located on the dashboard. The head lamps will only operate when engine is running. See Figure 10.

AMMETER

The ammeter registers the rate of battery charge or discharge. The ammeter will register on the discharging side with starting the engine. It should register on the opposite side (charging) when the engine is running in the fast position until the battery is completely charged. With a fully charged battery or with the engine idling, the ammeter will not show a charge. See Figure 10.

HYDROSTATIC CONTROL LEVER

The hydrostatic control lever is located on top of the fender on the right side of the tractor. This single control lever, connected to the hydrostatic transmission, controls both the speed and direction of the tractor. Infinite speed control is achieved by moving the control lever forward or backward. The farther forward or backward you move the control lever, the faster you will travel. Pulling the control lever into neutral (N) area will stop the tractor. See Figure 11.

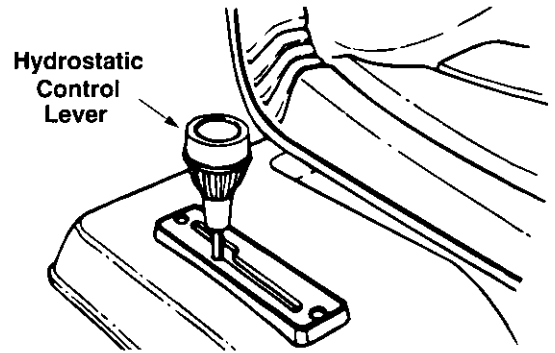

Figure 11

CLUTCH-BRAKE PEDAL

The clutch-brake pedal is located on the left side of the tractor. See Figure 10. Depressing pedal returns the drive unit to neutral (N) and applies the brake.

NOTE: The clutch-brake pedal must be depressed to start the engine.

PARKING BRAKE

To set the parking brake, depress the clutch-brake pedal, pull up the parking brake knob and release the clutch-brake pedal. It will stay in the raised position. To release the parking brake, depress and release the clutch-brake pedal while pushing down on the parking brake knob. See Figure 12.

NOTE: The parking brake must be set if the operator leaves the seat with the engine running.

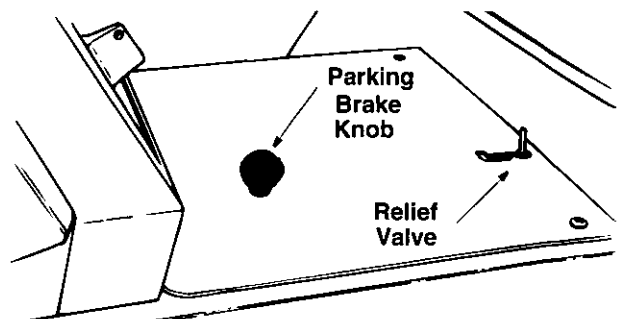

Figure 12

RELIEF VALVE

A hydrostatic relief valve is provided so the unit can be moved without the engine running. The lever which operates the relief valve is located on the console. See Figure 12.

To operate the relief valve, place the hydrostatic control lever in neutral, release the parking brake, push the lever forward and to the right to lock. Be certain to release the lever by pushing it to the left before operating the engine.

CUTTING CONTROLS

A. LIFT LEVER

The lift lever is used to raise and lower the cutting deck and to engage and disengage the blades. Pulling it all the way back and locking it disengages the blades.

NOTE: The lift lever must be in the BLADES OFF position when starting the engine, when shifting into reverse and if the operator leaves the seat. See Figure 13.

B. DECK LIFT INDICATOR

The deck lift indicator (if so equipped) marks the position being used for the lift lever. Select the lift lever position desired, press the indicator lever outward, move it to the position immediately below the lift lever and release the indicator lever. See Figure 13.

C. SETTING THE CUTTING HEIGHT

1. Select the position for the lift lever which gives the desired cutting height. Move the deck lift indicator (if so equipped) so that the lift lever can be returned to the same position after it is raised.
2. Move the deck wheels (if so equipped) to the hole location so the wheels are 1/4 to 1/2 inch above the ground.

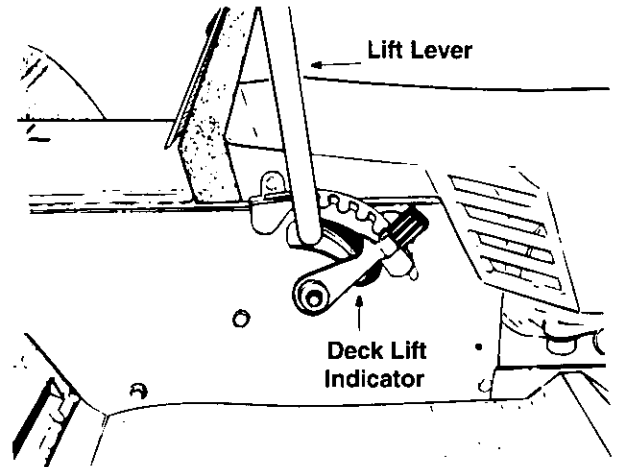

Figure 13

SECTION 7: OPERATION



WARNING

AVOID SERIOUS INJURY OR DEATH

- GO UP AND DOWN SLOPES, NOT ACROSS. • AVOID SUDDEN TURNS.
- DO NOT OPERATE THE UNIT WHERE IT COULD SLIP OR TIP.
- IF MACHINE STOPS GOING UPHILL, STOP BLADE(S) AND BACK DOWNHILL SLOWLY.
- DO NOT MOW WHEN CHILDREN OR OTHERS ARE AROUND.
- NEVER CARRY CHILDREN.
- LOOK DOWN AND BEHIND BEFORE AND WHILE BACKING.
- KEEP SAFETY DEVICES (GUARDS, SHIELDS, AND SWITCHES) IN PLACE AND WORKING.
- REMOVE OBJECTS THAT COULD BE THROWN BY THE BLADE(S).
- KNOW LOCATION AND FUNCTION OF ALL CONTROLS.
- BE SURE BLADE(S) AND ENGINE ARE STOPPED BEFORE PLACING HANDS OR FEET NEAR BLADE(S).
- BEFORE LEAVING OPERATOR'S POSITION, DISENGAGE BLADE(S), PLACE THE SHIFT LEVER IN NEUTRAL, ENGAGE BRAKE LOCK, SHUT ENGINE OFF AND REMOVE KEY.

READ OPERATOR'S MANUAL

GAS AND OIL FILL-UP

Check the oil level and add if necessary. Service the engine with gasoline as instructed in the separate engine manual packed with your tractor. Read instructions carefully.

IMPORTANT: Your tractor is shipped with oil; however you must check the oil level before operating. Be careful not to overfill.

STARTING THE ENGINE

IMPORTANT: This unit is equipped with a safety interlock system for your protection. The purpose of the safety interlock system is to prevent the engine from cranking or starting unless the clutch-brake pedal is depressed and the lift lever is in the BLADES STOP position. In addition, the lift lever must be in the BLADES STOP position when the unit is put into reverse or the engine will shut off. If the operator leaves the seat with the lift lever engaged and/or without setting the parking brake, the engine will shut off.



WARNING: Do not operate the tractor if the interlock system is malfunctioning because it is a safety device, designed for protection.

1. Place the lift lever in the **BLADES STOP** position.
2. Depress the clutch-brake pedal and set the parking brake.
3. Place the hydrostatic control lever in the **NEUTRAL (N)** position.
4. Set the throttle control in the **FAST** position.
5. Pull out the choke control (a warm engine may not require choking).
6. Turn the ignition key to the right to the **START** position. After the engine starts, release the key. It will return to the **ON** position.

NOTE: Protect the starter life by using short starting cycles of several seconds. Cranking more than 15 seconds per minute can damage the starter motor.

7. Push choke knob in gradually. Move the throttle control to desired engine speed.

STOPPING THE ENGINE

Turn the ignition key to the left to the **OFF** position. Remove the key to prevent accidental starting.

IMPORTANT: If you strike a foreign object, stop the engine. Remove wire from spark plug, thoroughly inspect the unit for any damage, and repair the damage before restarting and operating the mower.

NOTE: If any problems are encountered, refer to the Trouble Shooting Guide.

OPERATING THE LAWN TRACTOR

1. Move throttle control to full throttle to prevent strain on the engine and to operate the cutting blades.
2. Depress the clutch-brake pedal so the parking brake is released, and then release the clutch-brake pedal.
3. Place the hydrostatic control lever in either the **FORWARD** or **REVERSE** position. The farther forward you move the hydrostatic control lever, the faster you will travel.



WARNING: Look to the rear before backing up.

To stop the lawn tractor, pull the hydrostatic control lever into **NEUTRAL (N)** or depress the clutch-brake pedal.

Be sure that the lawn is clear of stones, sticks, wire, or other objects which could damage lawn tractor or engine. For best results and to insure more even grass distribution, do not mow when lawn is excessively wet.



WARNING: Before leaving the operator's position for any reason, disengage the blades, place the hydrostatic control lever in neutral, engage the parking brake, shut engine off and remove the key.

When stopping the unit to empty a grass bag, etc., follow the instructions above. This procedure will also eliminate "browning" the grass, which is caused by hot exhaust gases from a running engine.

GRASS COLLECTOR AVAILABLE

Grass Collector Model 190-063-000 is available as optional equipment.



WARNING: The mower should not be operated without the entire grass catcher or chute deflector in place.

NOTE: Under normal usage bag material is subject to wear, and should be checked periodically. Be sure to use only factory authorized replacement bag.

SECTION 8: ADJUSTMENTS



WARNING: Disconnect the spark plug wires and ground against the engine before performing any adjustments, repairs or maintenance.

SEAT ADJUSTMENT

To adjust the position of the seat, move the seat adjustment lever (located under the seat) to the left and slide the seat forward or backwards. See Figure 14. Make sure seat is locked into one of the six adjustment positions before operating the lawn tractor.

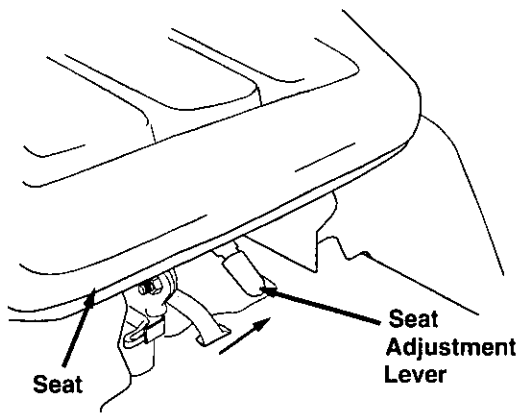

Figure 14

HYDROSTATIC NEUTRAL CONTROL ADJUSTMENT

The hydrostatic transmission control is in correct adjustment when the tractor does not move with the engine running, the clutch engaged and the hydrostatic control lever in the neutral position.

If adjustment is necessary, follow these steps:

1. Raise both rear wheels off the ground by placing blocks under the rear frame.
2. Remove transmission panel by removing the parking brake knob, rubber boot on relief valve and truss machine screws.
3. Loosen the hex jam nut on the speed selector adjusting rod. See Figure 15.

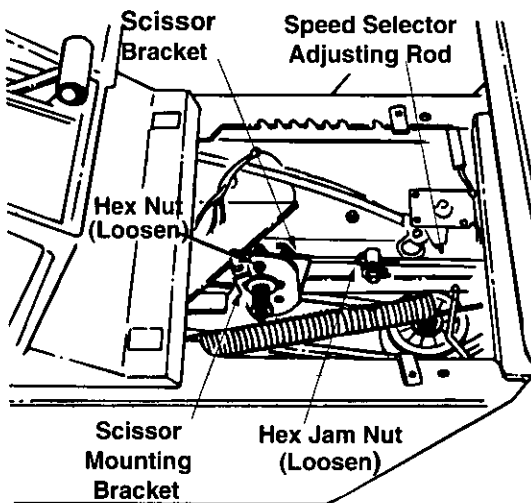

Figure 15

4. Loosen the hex nut on the scissor mounting bracket. See Figure 15.
5. Start the engine and run at full throttle.
6. Move the hydrostatic control lever until you find neutral (rear wheels do not rotate in either direction).
7. Depress the clutch-brake pedal until the scissor brackets come together.
8. Shut off the engine.
9. Tighten hex nut on the scissor mounting bracket.
10. Thread the speed selector rod in or out of the ferrule until the hydrostatic control lever lines up in the neutral position on the speed control index bracket.
11. Tighten hex jam nut against the ferrule.
12. Replace the transmission panel, rubber boot on relief valve and parking brake knob.
13. Remove the blocks from under the frame and test the operation of the tractor.

DECK LEVELING ADJUSTMENT

If an uneven cut is obtained, the deck may be leveled by following instructions in Assembly section.

DECK ENGAGEMENT ADJUSTMENT

The cutting deck engagement may be adjusted to make certain deck is disengaged when lift lever is in the BLADES STOP position. Correct adjustment as follows.

With the engine off, place the lift lever in the highest cutting position (first position). Remove the cotter pin and flat washer which secure the disengagement rod to the stabilizer shaft assembly. See Figure 16. Shorten the rod by threading it in until the ferrule is against the back of the slot in the lift shaft assembly, and the rod lines up with the hole in the stabilizer shaft. For more belt tension the disengagement rod must be lengthened. To decrease belt tension the disengagement rod must be shortened.

Check the adjustment by placing the lift lever in the BLADES STOP position. The deck should move up and forward, allowing the belt to become loose. Start and test for disengagement. Repeat procedure as necessary.

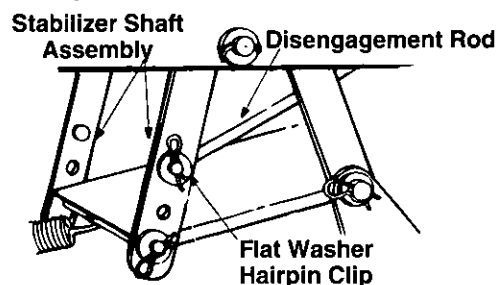

Figure 16

BRAKE ADJUSTMENT (See Figure 17)

The brake is located by the right rear wheel inside the frame. The brake has been set at the factory to the proper clearance. During normal operation of this machine, the brakes are subject to wear and will require periodic examination and adjustment.



WARNING: Do not have the engine running when you adjust the brake.

To adjust the brake, adjust the nut so the brake starts to engage when the brake lever is 1/4" to 5/16" away from the axle housing.

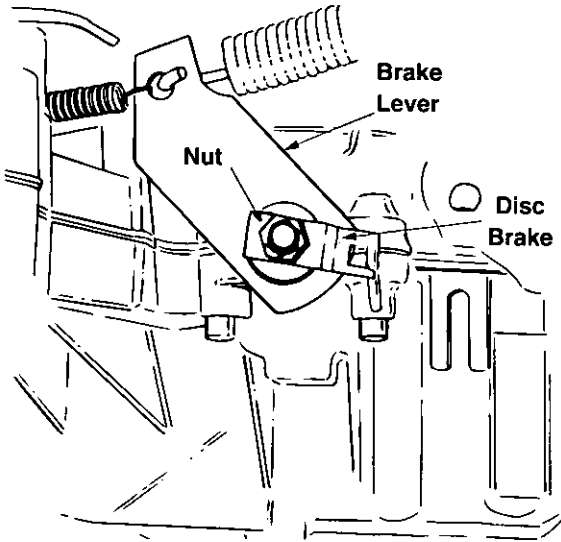

Figure 17

CARBURETOR ADJUSTMENTS



WARNING: If any adjustments are made to the engine while the engine is running (e.g. carburetor), disengage all clutches and blades. Keep clear of all moving parts. Be careful of heated surfaces and muffler.

Minor carburetor adjustments may be required to compensate for differences in fuel, temperature, altitude and load. Refer to separate engine manual for carburetor adjustment information.

NOTE: A dirty air cleaner will cause an engine to run rough. Be certain air cleaner is clean and attached to the carburetor before adjusting carburetor.

SECTION 9: LUBRICATION



WARNING: Always stop engine and disconnect spark plug wire before cleaning, lubricating or doing any kind of work on lawn tractor.

STEERING GEARS

Lubricate teeth of steering gears with automotive multi-purpose grease after every 25 hours of operation or once a season. See Figure 18.

STEERING SHAFT

Lubricate steering shaft at least once a season with light oil.

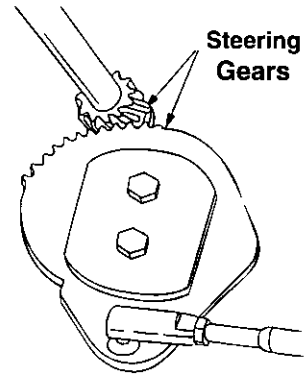

Figure 18

HYDROSTATIC TRANSMISSION

The hydrostatic transmission is filled at the factory and does not require checking. If repairs are needed, contact your local service dealer. (Hydrostatic transmission contains approximately 2.5 quarts of SAE 20W50 oil.)

LINKAGE

Once a season lubricate all the pivot points on the clutch, brake and lift linkage with SAE 30 engine oil.

WHEELS

The front wheels are provided with grease fittings. The rear wheels must be removed from the axle for lubrication. Lubricate at least once a season with automotive multi-purpose grease.

PIVOT POINTS

Lubricate all pivot points with light oil at least once a season.

BALL JOINTS

The ball joints and drag link ends are permanently lubricated.

SECTION 10: MAINTENANCE



WARNING: Disconnect the spark plug wire and ground against the engine before performing any adjustments, repairs or maintenance.

TROUBLE SHOOTING

Refer to the trouble shooting chart for engine problems.

ENGINE

Refer to the separate engine manual for engine maintenance instructions.

Service **air cleaner** every 10 hours under normal conditions. Clean every few hours under extremely dusty conditions. To service the air cleaner, refer to the separate engine manual packed with your unit.

The **spark plug(s)** should be cleaned and the gap reset once a season. Spark plug replacement is recommended at the start of each mowing season; check engine manual for correct plug type and gap specifications.

Maintain **engine oil** as instructed in the separate engine manual packed with your unit. Read and follow instructions carefully.

Oil Drain Sleeve

Your lawn tractor has a plastic oil drain sleeve packed with the loose parts for your convenience in draining oil from the crankcase. To drain the oil, snap small end of oil drain sleeve onto oil sump. See Figure 19. Remove drain plug and drain oil into a suitable container.

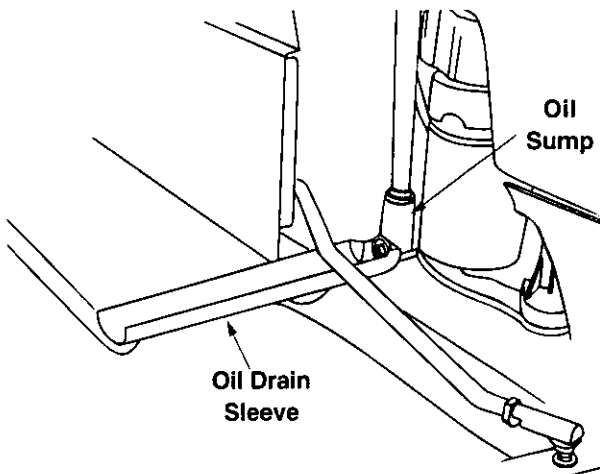

Figure 19

FUEL FILTER

Your unit is equipped with a replaceable in-line fuel filter. Replace filter whenever contamination or discoloration is noticed. Order replacement filter through your authorized engine service dealer.

HYDROSTATIC TRANSMISSION COOLING

The hydrostatic transmission is cooled by the oil, fan and fins. If the hydrostatic transmission runs hot, check to see if the fan is in operating condition, the oil level is correct and the fins are clean.

NOTE: DO NOT use high pressure water spray or steam to clean the hydrostatic transmission.

CLEANING ENGINE AND DECK

Any fuel or oil spilled on the machine should be wiped off promptly. Grass, leaves, and other dirt must not be left to accumulate around the cooling fins of the engine or on any part of the machine. Clean the underside of the deck after each mowing.

WHEEL ADJUSTMENT

The caster (forward slant of the king pin) and the camber (tilt of the wheels out at the top) require no adjustment. Automotive steering principles have been used to determine the caster and camber on the tractor. The front wheels should toe-in between 1/16 - 5/16 inch.

To adjust the toe-in, follow these steps.

1. Remove the hex nut and lock washer, and drop the end of the tie rod from the axle bracket. See Figure 20.
2. Loosen the hex jam nut on tie rod.
3. Adjust the tie rod assembly for correct toe-in.

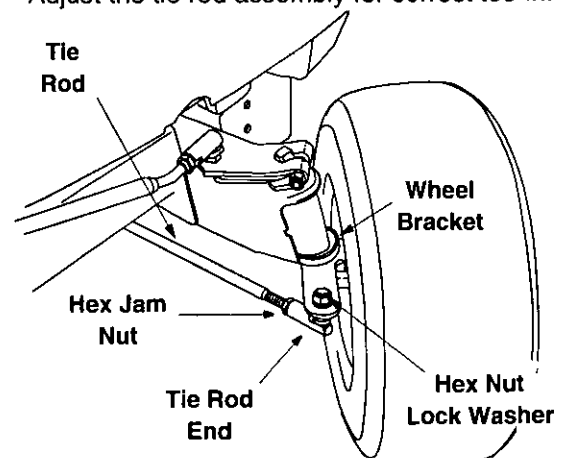

Figure 20

Dimension "B" should be approximately 1/16 - 5/16" less than Dimension "A." See Figure 21. To increase Dimension "B," screw tie rod into tie rod end. To decrease Dimension "B," unscrew tie rod from tie rod end. Reassemble tie rod. Check dimensions. Readjust if necessary.

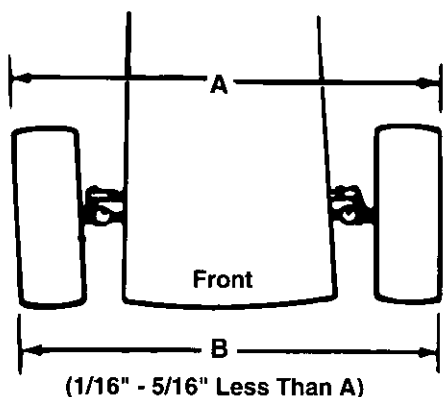

Figure 21

CUTTING BLADES

A. Removal For Replacement Or Sharpening



WARNING: Be sure to disconnect and ground the spark plug wire(s) and remove ignition key before working on the cutting blade to prevent accidental engine starting. Protect hands by using heavy gloves or a rag to grasp the cutting blades.

1. Remove the hex flange nut which holds the blade to the blade spindle.
2. Remove the blade from the spindle.

B. Sharpening

Remove the cutting blades by following the directions of the preceding section.

When sharpening the blades, follow the original angle of grind as a guide. It is extremely important that each cutting edge receives an equal amount of grinding to prevent an unbalanced blade. An unbalanced blade will cause excessive vibration when rotating at high speeds, may cause damage to the mower and could break, causing personal injury.

The blade can be tested for balance by balancing it on a round shaft screwdriver. Remove metal from the heavy side until it balances evenly.

C. Reassembly

When replacing blades, be sure to install the blade with the side of the blade marked "Bottom" (or with part number) facing the ground when the mower is in the operating position. Carefully align "star" on blade with "star" on spindle. Secure with hex flange nut.

BLADE MOUNTING TORQUE

Hex Flange Nut: 840 in. lb. min., 1080 in. lb. max.
To ensure safe operation of your unit, **all** nuts and bolts must be checked periodically for correct tightness.

BATTERY CARE AND MAINTENANCE (TYPE "A" BATTERY)

Type "A" batteries are sealed and are maintenance free.

BATTERY CARE AND MAINTENANCE (TYPE "B" BATTERY)

CHECK FLUID LEVEL

Check fluid level inside each cell of the battery every two weeks and before and after charging. Always keep level between maximum and minimum fill level. **Add only distilled water. Never add additional acid** or any other chemicals to the battery after initial activation.

NOTE: After operating the lawn tractor for a long period of time, check the fluid level in the battery as it can overheat and lose fluid.

CHARGING THE BATTERY (ALL BATTERIES)

The engine is equipped with an alternator which charges battery when tractor is operated. Under normal conditions, the battery only needs to be charged before, during and after off-season storage. Follow the instructions under "Off-Season Storage."
To charge the battery: Battery P/N 725-1705D—Charge at 2-3 amps for one hour. Battery P/N 725-1707D, 725-0453G, and 725-1750—Charge at 6 amps for one hour.

REMOVING / INSTALLING / JUMP STARTING



WARNING: When removing or installing the battery, follow these instructions to prevent the screwdriver from shorting against the frame.

Removing the Battery: Disconnect negative cable first, then positive cable.

Installing the Battery: Connect positive cable first, then negative cable.

Jump Starting

1. First, connect end of one jumper cable to the positive terminal of the good battery, then the other end to the positive terminal of the dead battery.
2. Connect the other jumper cable to the negative terminal of the good battery, then to the **FRAME OF THE UNIT WITH THE DEAD BATTERY.**



WARNING: Failure to use this procedure could cause sparking, and the gas in either battery could explode.

CLEAN THE BATTERY

Clean the battery by removing it from the unit and washing with a baking soda and water solution. If necessary, scrape the battery terminals with a wire brush to remove deposits. Coat terminals and exposed wiring with grease or petroleum jelly to prevent corrosion.

BATTERY FAILURES

Some common causes for battery failure are: incorrect initial activation, lack of water, adding chemicals other than water after initial activation, undercharging, overcharging, corroded connections, freezing. **These failures do not constitute warranty.**

TIRES

Recommended operating tire pressure is approximately 10 p.s.i. Maximum tire pressure under any circumstances is 30 p.s.i. Equal tire pressure should be maintained on all tires.

When installing a tire to the rim, be certain rim is clean and free of rust. Lubricate both the tire and rim generously. Never inflate to over 30 p.s.i. to seat beads.



WARNING: Excessive pressure (over 30 p.s.i.) when seating beads may cause tire/rim assembly to burst with force sufficient to cause serious injury.

BELT REMOVAL AND REPLACEMENT



WARNING: Disconnect the spark plug wire(s) and ground it against the engine. Block the wheels of the unit.

NOTE: Figure 22 and 24 are shown with the unit tipped up for clarity. It is not necessary to tip the unit to remove the belts.

However, if tipping the unit is desired, remove the battery from the unit. To prevent gasoline leakage, drain the gasoline, or remove the fuel tank cap, place a thin piece of plastic over the neck of the fuel tank and screw on the cap. Be certain to remove the plastic when finished changing the belts. Block unit securely.

DECK BELT

1. Place the lift lever in the engaged (all the way forward) position.
2. Disconnect the spring which is attached to a bracket on the transaxle, inside the right rear wheel. Use a spring puller or other suitable tool.

NOTE: When reassembling, make certain belt keeper pins are assembled in the same locations from which they were removed. See Figure 22.

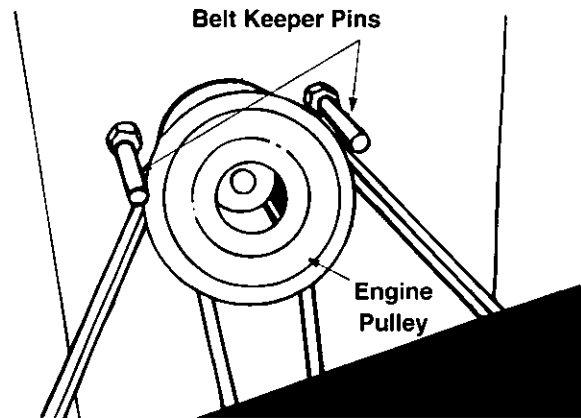

Figure 22

3. Place lift lever in the **BLADES STOP** position.
4. Remove the belt keeper pins from the lower frame. See Figure 22.
5. Unhook the deck belt from the engine pulley.
6. Place the lift lever in the engaged (all the way forward) position.
7. Disconnect the stabilizer plate from the stabilizer shaft assembly by removing the hairpin clips and flat washers and sliding out the rod. Refer to Figure 16.
8. Disconnect the six deck links by removing the hairpin clips and flat washers.
9. Place the lift lever in the **BLADES STOP** position.
10. Slide the deck from beneath the lawn tractor.
11. Remove the belt guards at each deck pulley by removing the self-tapping screws. See Figure 23.

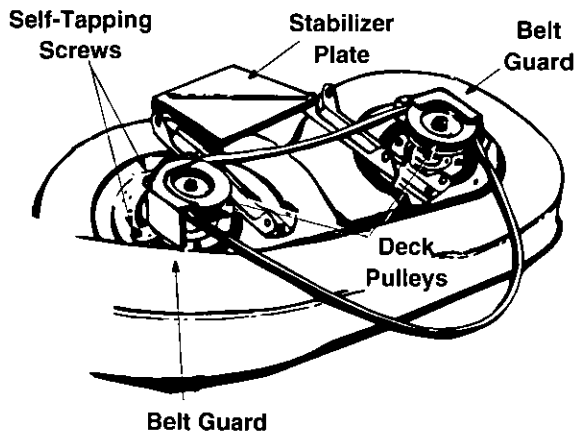

Figure 23

12. Remove and replace the belt, reassemble following the instructions in reverse order.

DRIVE BELT (See Figure 24)

1. Depress the clutch pedal and set the parking brake.
2. Remove the deck from the lawn tractor.
3. Raise and block the front wheels of the lawn tractor so you can work under it.
4. Remove the transmission panel by removing the parking brake knob, rubber boot on relief valve and truss machine screws.
5. Raise the seat. Disconnect the battery cables. Remove the battery from the unit.
6. Disconnect the idler pulley spring which is attached to a bracket on the frame, inside the left rear wheel. Use a spring puller or other suitable tool.
7. Remove the three self-tapping screws from the cooling fan. Remove the fan.

8. Remove the center bolt, lock washer and flat washer, and let the engine pulley drop down so the belt is past the belt guards.
9. Roll the belt off of top sheave of engine pulley, onto the pulley hub.
10. Remove the belt from the transmission pulley and engine pulley, and remove from the unit.
11. Reassemble using a new belt, following instructions in reverse order.

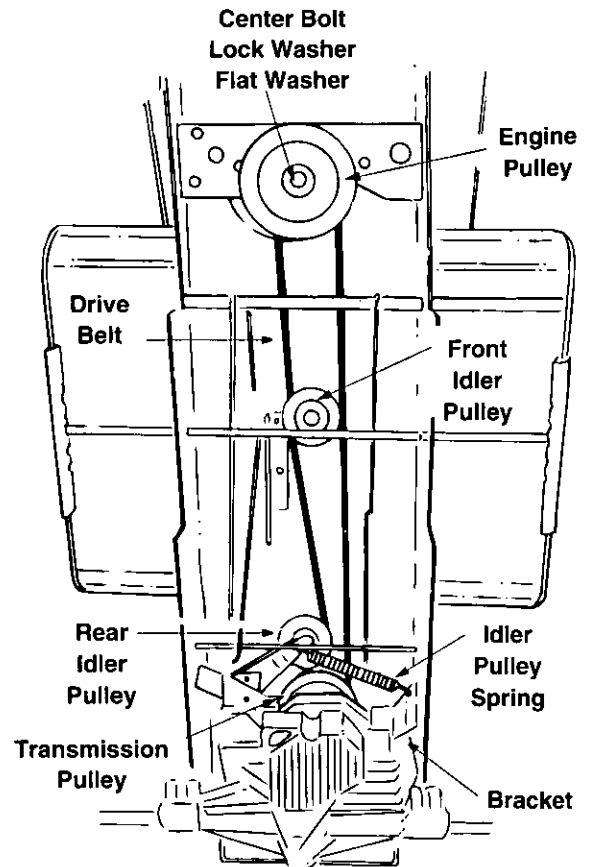

Figure 24

SECTION 11: OFF-SEASON STORAGE

If the machine is to be inoperative for a period longer than 30 days, prepare for storage as follows.

1. Clean the engine and the entire unit thoroughly.
2. Lubricate all lubrication points. Wipe the entire machine with an oiled rag to protect the surfaces.
3. Refer to the engine manual for correct engine storage instructions. The engine must be completely drained of fuel to prevent gum deposits from forming on essential carburetor parts, fuel lines and fuel tanks.
4. **Charge battery fully.** The battery loses some of its charge each day when the unit is not used.

NEVER store battery without a full charge. Recharge battery before returning to service or every two months, whichever occurs first.

5. When storing unit for extended periods, disconnect battery cables. Removing battery from unit is recommended.
6. Store unit in a clean, dry area. Do not store next to corrosive materials, such as fertilizer.

NOTE: When storing any type of power equipment in an unventilated or metal storage shed, care should be taken to rustproof the equipment. Using a light oil or silicone, coat the equipment, especially any chains, springs, bearings and cables.

SECTION 12: TROUBLE SHOOTING GUIDE

Trouble	Possible Cause(s)	Corrective Action
Engine will not crank	<p>Safety switch button not depressed.</p> <p>Battery installed incorrectly.</p> <p>Battery is dead or weak.</p> <p>Blown fuse or circuit breaker.</p> <p>Engine ground wire loose.</p>	<p>There are two switches in the starting circuit of your unit: the clutch pedal switch and the deck lift lever switch. Make certain the actuator is fully depressing the buttons on each switch.</p> <p>The battery must be installed with negative terminal attached to black ground wire. Negative terminal is identified at the post by "NEG", "N" or "-". The positive terminal, identified by "POS", "P" or "+", must be attached to the big red wire which goes to the solenoid. All batteries are to be fully charged before installing. Refer to "Quick Start" battery guide that came with the operator's manual.</p> <p>Check fluid level in battery. If fluid is low, fill to just below split rings with water. Charge with 6 AMP charger until fully charged.</p> <p>Refer to operator's manual for fuse box location. Replace fuse with automotive type fuse. Fuses seldom fail without a reason. The problem must be corrected. Check for loose connections in the fuse holder. Replace fuse holder if necessary. A dead short may be in the cranking or charging circuit where the insulation may have rubbed through and exposed the bare wire. Replace the wire or repair with electrician's tape if the wire strands have not been damaged.</p> <p>Note: Look for a wire pinched between body panels, burned by the exhaust pipe or muffler or rubbed against a moving part.</p> <p>Engine should have a black ground wire running from engine to frame or mounting bolt.</p>
Engine cranks but will not start	<p>Throttle or choke not in starting position.</p> <p>No fuel to the carburetor.</p> <p>No spark to spark plug.</p> <p>Dirty air cleaner.</p>	<p>Check operator's manual for correct position for throttle control and choke for starting.</p> <p>Gasoline tank empty. Fill.</p> <p>Fuel line or in-line fuel filter plugged. Remove and clean fuel line. Replace filter if necessary.</p> <p>Spark plug lead disconnected. Connect lead. Hold spark plug lead away from engine block about 1/8". Crank engine. There should be a spark. If not, have engine repaired at authorized engine service dealer.</p> <p>Faulty spark plug. To test, remove spark plug. Attach spark plug lead to spark plug. Ground the spark plug body against the engine block. Crank the engine. The spark plug should fire at the electrode. Replace if it does not.</p> <p>If the air cleaner is dirty, the engine may not start. Refer to the engine manual packed with your unit.</p>
Engine smokes	<p>Engine oil has been overfilled.</p> <p>Engine loses crankcase vacuum.</p>	<p>Check oil level.</p> <p>Dipstick not seated or broken. Replace defective part.</p> <p>Engine breather defective. Replace.</p>
Excessive vibration	<p>Bent or damaged blade.</p> <p>Bent blade.</p>	<p>Stop engine immediately. Check all pulleys, blade adapters, keys and bolts for tightness and spindle damage. Tighten or replace any damaged parts.</p> <p>Stop engine immediately. Replace damaged blade. Only use original equipment blades.</p>
Mower will not discharge grass or leaves uncut strips	<p>Engine speed low.</p> <p>Speed selection.</p> <p>Cutting height set too low.</p> <p>Blades short or dull.</p>	<p>Throttle must be set at full throttle.</p> <p>Use lower ground speed. The slower your ground speed, the better the quality of cut. Raise deck.</p> <p>Sharpen or replace blades (uncut strip problem only).</p>

Note: For repairs beyond the minor adjustments above, contact your local authorized service dealer

SECTION 13: OPTIONAL EQUIPMENT

At the time of manufacture of lawn tractor, the following optional equipment is available.

NOTE: These lawn tractors are not designed for ground-engaging equipment (tillers, plows, etc.).

*Available through your local dealer or from Agri-Fab Inc., 303 W. Raymond Street, Sullivan, Illinois 61951.

Description	Model No.
40" Two Stage Snow Thrower	190-621-000
42" Dozer Blade	190-620-000
Mulching Kit	190-112-000
Twin Bag Grass Collector	190-063-000
Front Counterweight	190-745-000
Tire Chains—20 x 8	190-658-000
31 Lb. Wheel Weights	190-215-000
Gang Reel (Set of three)	45-0195*
38" Lawn Sweeper	45-0222*
Heavy Duty Dump Cart	45-0171*
Tine De-Thatcher	45-0186*

SECTION 14: LABELS

LABELS	
PART NO.	DESCRIPTION
777D00598	RT Hoodside
777D00599	LT Hoodside
777D00608	Lower Side Panel
777D00616	WOP Engine Label
777D01458	WOP Rear Fender
777I20105	Left Dash
777I20107	Right Dash
777I20217	Lower Dash
777I20270	Deck Lift
777S30010	Chute Danger Label
777S30012	Assemble Chute Label
777S30018	Deck Safety Label
777S30029	Transmission Cover Label
777S30107	WOP Safety Seat

Model 693

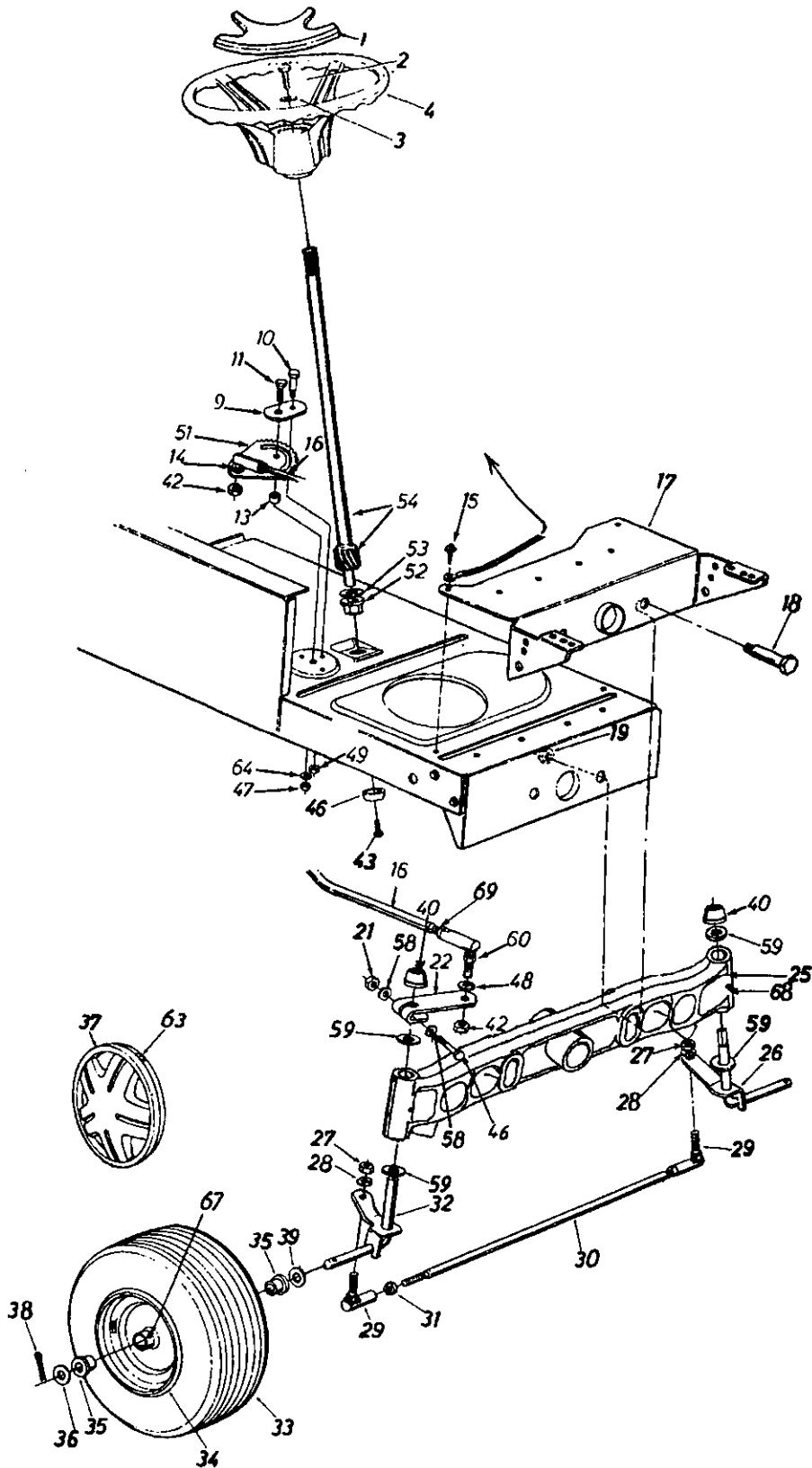

Model 693

REF. NO.	PART NO.	DESCRIPTION	REF. NO.	PART NO.	DESCRIPTION
1	731-1509A	Steering Wheel Cap		734-0864	Tire Only
2	710-0643	Hex Bolt 5/16-18 x 1" Lg.		734-0255	Air Valve
3	736-0242	Belleville Wash. .345" I.D.	34	634-0051	Front Wheel Rim Only
4	731-1686	Steering Wheel	35	741-0569	Bearing
5	731-0954	Steering Bellow—9"	36	736-0285	FI-Wash. .635 I.D. x 1.59" O.D.
9	17198A	Retainer Plate	37	731-0484A	Front Wheel Hub Cap
10	738-0141	Shld Bolt .437" Dia. x.35 Lg. 5/16-18	38	714-0470	Cotter Pin 1/8" Dia. x 1.25**
11	710-0152	Hex Bolt 3/8-24 x 1.0" Lg. (Gr. 5)	39	736-0366	FI-Wash.5/8" x 1.004 x .120
13	750-0535	Spacer .380" I.D. x .625" O.D. x .227	40	726-0214	Push Cap 5/8" Dia. Rod
14	736-0217	L-Wash. 3/8" I.D. (H.D.)	42	712-0262	Hex Jam Nut 3/8-24 Thd.
15	710-0726	Hex Wash. Hd. Self-Tap Scr.	43	710-1309	Hex Patch Bolt 5/16-18 x .62**
16	711-1107	Steering Drag Link	46	748-0389	Cap
17	783-0041B	Front Pivot Brkt.	47	712-0214	Hex Cent. L-Nut 3/8-24 Thd.
18	738-0527	Shld Bolt .498" Dia. x 2.04 Lg. 3/8-16	48	736-0217	L-Wash. 3/8" I.D.*
19	712-0431	Flanged L- Nut 3/8-16 Thd.*	49	712-0158	Hex Cent. L-Nut 5/16-18 Thd.
21	712-0411	Hex L-Nut 5/16-24 Thd.	51	717-0622A	Steering Gear Segment
22	16481A	Steering Arm Front Axle	52	741-0656	Hex Flg. Brg. .634 I.D.
23	710-0772	Hex Bolt 5/16-24 x 2.00" Lg. (Gr.5)	53	736-0187	FI-Wash. (Hardened)
24	741-0659	Hex Flg. Brg. .632 I.D.	54	738-0919	Steering Shaft
25	683-0128A	Pivot Bar Ass'y.	58	736-0271	Wave-Wash. .32" I.D. x .62" O.D.
26	683-0127	Front Axle Ass'y.—L.H.	59	736-0187	FI-Wash. (Hardened)
27	712-0241	Hex Nut 3/8-24 Thd.*	60	723-0448A	Drag Link Ball Joint 3/8-24 Thd.
28	736-0169	L-Wash. 3/8" I.D.*	63	727-0425A	Spring Clip
29	723-3018	Ball Joint 3/8-24 Thd.	64	736-0356	Bell-Wash. .39" I.D. x 1.38" O.D.
30	747-0753	Tie Rod (Adjustable)	65	731-1291A	Pivot Bar End Cap (Optional) Not Shown
31	712-0711	Hex Jam Nut 3/8-24 Thd.*	67	737-0280	Grease Fitting
32	683-0126	Front Axle Ass'y.—R.H.	68	737-3000	Grease Fitting
33	634-0059	Wheel Ass'y. Comp.	69	712-0240	Jam Nut 7/16-20

Model 693

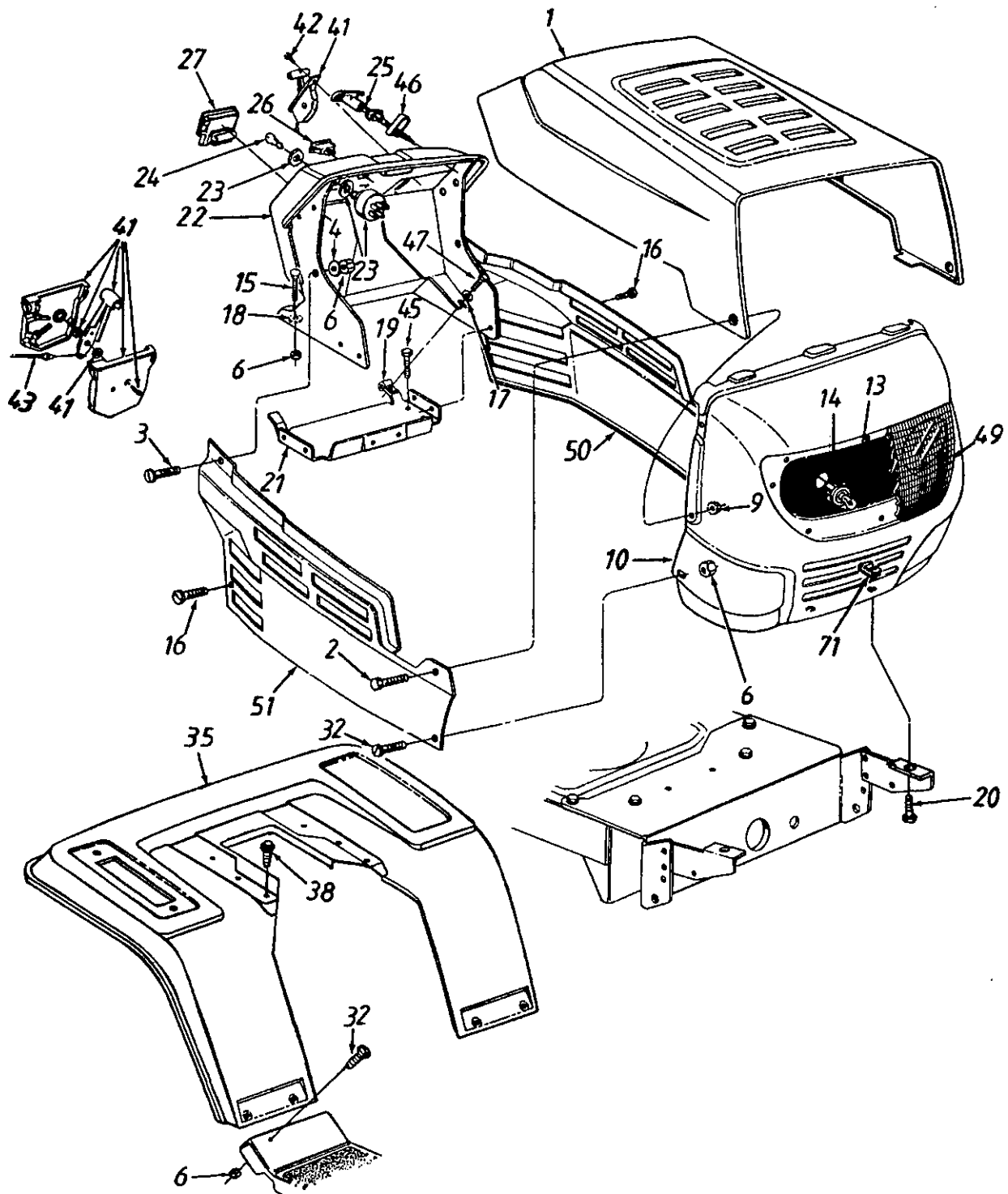

Model 693

REF. NO.	PART NO.	DESCRIPTION	REF. NO.	PART NO.	DESCRIPTION
1	783-0250	Hood	24	725-0201	Ignition Key
2	738-0952	Shld. Bolt .375" Dia. x .125" Lg.	25	746-0616A	Choke Control
3	710-0924	Scr. 1/4-20 x .75	26	725-0634	Light Switch
4	736-0342	Wash. .283 x .030	27	725-0925	Ammeter
6	712-0271	Hex Sems Nut 1/4-20 Thd.	32	710-0286	Truss Mach. Scr. 1/4-20 x .5" Lg.
9	712-3027	Flange L-Nut 1/4-20 Thd.	35	783-0350	Fender
10	783-0156A	Grille	38	710-0726	Hex Wash. Hd. AB-Tap Scr.5/16 x .75"
13	725-0963	Lamp	41	831-0823A	Throttle Box Ass'y.
14	725-1651	Socket	42	710-0779A	Truss Mach. AB-Tap Scr.#10 x .5" Lg.
15	710-0703	Carriage Bolt 1/4-20 x .75" Lg.	43	746-0776	Throttle Control Wire
16	710-0599	Hex Washer TT-Tap Scr.1/4-20 x .5"	45	710-0607	Hex Wash. Hd. B-Tap Scr.5/16-18 x .5"
17	736-0173	Fl-Wash. .281" I.D. x .73" O.D.	46	17782	Choke Retainer
18	726-0233	Bolt Retainer 1/4" I.D.	47	710-0642	Hex TT-Tap Scr. 1/4-20 x .75" Lg.
19	712-0185	Speed Nut 1/4-20	49	731-1503A	Lens
20	710-0118	Hex Bolt 5/16-18 x .75" Lg.	50	783-0151A	Side Panel—L.H.
21	17632A	Gas Tank Support Brkt.	51	783-0150A	Side Panel—R.H.
22	731-1692	Dash w/Ammeter Hole	71	726-0211	U-Nut 5/16-18 Thd.
23	725-1396	Ignition Switch			

NOTE: For **painted parts**, please refer to the list of color codes below. Please add the applicable color code, wherever needed, to the part number to order a replacement part. For instance, if a part, numbered 700-xxxx, is painted Oyster Gray, the part number to order would be 700-xxxx-0662.

Oyster Gray: 0662
Powder Black: 0637

Model 693

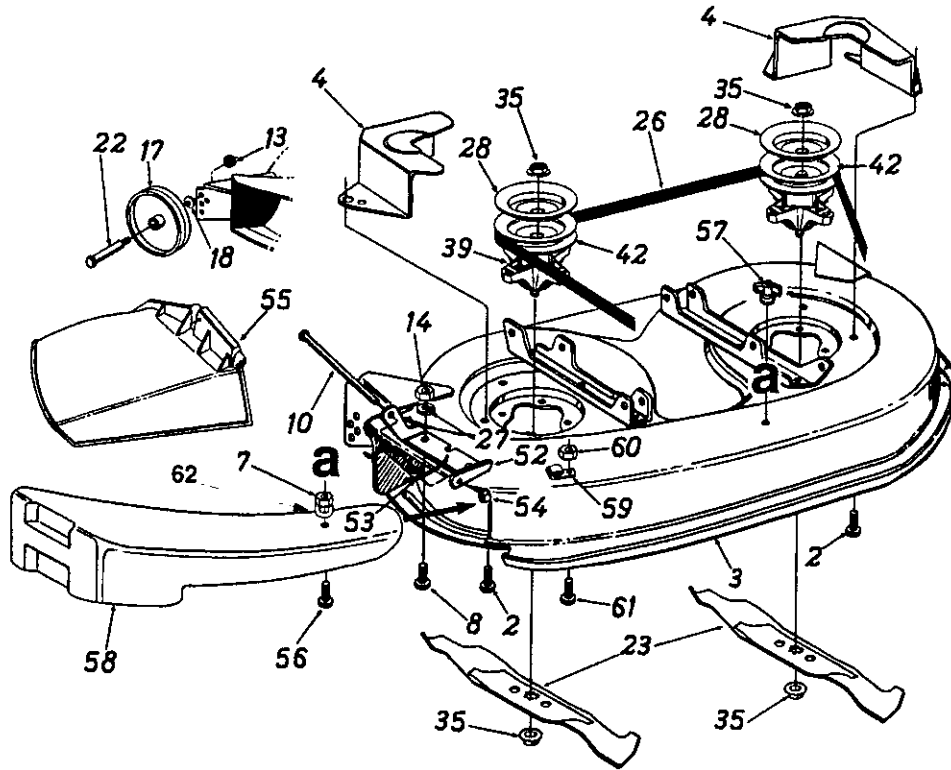

REF. NO.	PART NO.	DESCRIPTION	REF. NO.	PART NO.	DESCRIPTION
2	710-1260A	Hex Wash. Hd. TT-Tap Scr. 5/16-18 x .75" Lg.	33	710-0157	Hex Bolt 5/16-24 x .75" Lg.
3	683-0129	38" Deck Ass'y.	35	712-0417A	Hex Flange Nut 5/8-18 Thd.†
	813-6980	38" Deck Ass'y. Comp. (For Service Only)	37	736-0158	L-Wash. 5/8" I.D.*
4	783-0343A	Belt Guard Deck	39	618-0138	Blade Spindle Ass'y. Comp. (Incl. Ref. 28, 35, 42)
7	712-0291	Hex L-Nut 1/4-20 Thd.††	42	756-0969	5" Dia. Pulley†
8	710-0258	Hex Bolt 1/4-20 x .62"	52	703-1693	Hinge Mtg. Brkt.
10	711-0792	Hinge Pin	53	732-0602	Torsion Spring
13	712-0181	Hex Top L-Nut 3/8-16 Thd.	54	726-0106	Push Nut
14	712-3006	Hex Nut 1/4-20 Thd. (Gr. 5)	55	731-1032	Chute Ass'y. Comp. (Incl. Ref. 10, 52, 53, 54, 55)
17	734-0973	Deck Wheel—5"	56	710-0597	Hex Bolt 1/4-20 x 1" Lg.††
18	736-0105	Bell-Wash. .40" I.D. x .88" O.D.	57	712-3087	Wing Nut 1/4-20 Thd.
22	738-0373	Shld. Bolt .498" Dia. x 1.53"	58	731-1643A	Mulching Plug††
23	742-0610	3 in 1 Blade	59	16606	Retainer Hook Brkt.
26	754-0329A	V-Belt	60	712-0271	Hex Sems Nut 1/4-20 Thd.
27	736-0270	Bell-Wash. 1/4" I.D.	61	710-0258	Hex Bolt 1/4-20 x .62" Lg.
28	783-0342	Brake Disc	62	736-0173	Flat Washer .28 ID x .74 OD

† Deck pulleys and blade nuts must be torqued to 100 ft. lbs. if removed or replaced.

†† Optional

** Must be ordered with 4 digit color code.

IMPORTANT: For a proper working machine, use Factory Approved Parts.

V-BELTS are specially designed to engage and disengage safely. A substitute (non OEM) V-belt can be dangerous by not disengaging completely.

Model 693

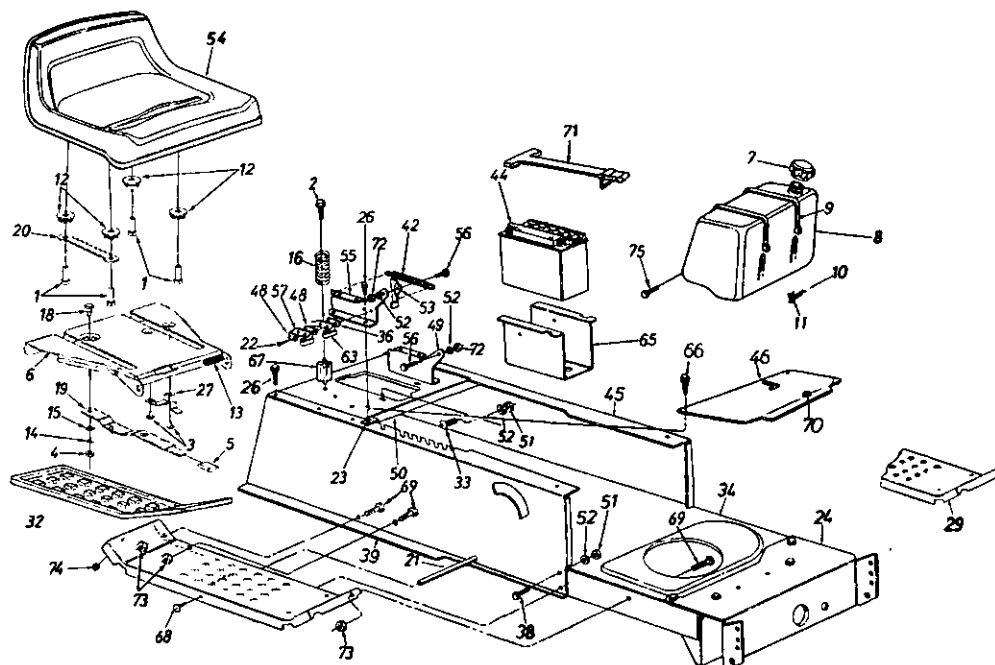

REF. NO.	PART NO.	DESCRIPTION	REF. NO.	PART NO.	DESCRIPTION
1	738-1007	Shoulder Screw 3/8-16 x .5	34	783-0310C	Lower Frame
2	710-1208	Hex Washer Tap Scr. 5/16-18 x 3.25" Lg.	36	726-0278	Insulator Boss Plate
3	710-1268	Hx Scr. B-Tap Wash. #10-16:.38 Lg.	38	710-3008	Hex Bolt 5/16-18 x .75" Lg.*
4	712-3027	Lock Nut 1/4-20	39	783-0042A	Upper Frame—R.H.
5	720-0309A	Grip	42	732-0581B	Extension Spring 5.31" Lg.
6	783-0607A	Seat Pivot Bracket	44	725-1750	12-V Battery
7	751-0603	Fuel Cap	45	783-0043	Upper Frame—L.H.
8	751-0657	Fuel Tank	46	783-0133B	Shift Cover
	749-0934	Fuel Tank Support Rod (Not Shown)	48	726-0279	Insulator Plate
9	726-0209	Tie Strap	49	17951	Seat Pivot Brkt. Support—L.H.
10	751-0535-15	Fuel Line	50	783-0355A	Hitch Plate
11	726-0205	Hose Clamp	51	712-3010	Hex Nut 5/16-18 Thd.*
12	731-1989	Seat Spacer	52	736-0119	L-Wash. 5/16" I.D.*
13	732-0499	Compression Spring	53	17239A	Seat Lift Brkt.
14	736-0175	Wash. Spring .265 x .562 x .025	54	757-0370A	Seat
15	736-0204	Fl. Wash. .344 ID x .62 OD x .03	55	17950	Seat Pivot Brkt. Support—R.H.
16	732-0735	Compression Spring	56	738-0296	Shld. Bolt .437" Dia. x .268"
18	738-0137A	Shldr. Scr. .340 x .285 - 1/4-20	57	725-1303	Spring Switch
19	783-0609	Seat Lever	63	725-1439	Safety Switch (Seat)
20	783-0753	Seat Selector	65	783-0345	Battery Tray
21	738-0526	Running Board Rod	66	710-0351	Truss Mach. B-Tap Scr. #10 x .5" Lg.
22	710-0227	Hex AB-Tap Scr. #8 x .50"	67	748-0347	Spring Spacer
23	726-0139	Speed Nut #10Z	68	710-0323	Pan Hd. Scr. 5/16-18 x .75" Lg.
24	783-0041B	Front Pivot Brkt.	69	710-3008	Hex Bolt 5/16-18 x .75" Lg.*
26	710-0726	Hex Washer AB-Tap Scr. 5/16 x .75" Lg.	70	731-0405	Snap Bushing
27	783-0611	Seat Stop	71	723-3064	Battery Retainer Strap
29	17770C	Running Board (R.H. & L.H.)	72	712-3010	Hex Nut 5/16-18 Thd. (Gr. 5)
32	731-0909	Rubber Foot Pad—L.H.	73	712-0265	Hex Sems Nut 5/16-18 Thd.
	731-0910	Rubber Foot Pad—R.H.	74	712-0271	Hex Sems Nut 1/4-20 Thd.
33	710-0323	Truss Mach. Scr. 5/16-18 x .75" Lg.	75	710-1189	Hex Screw 12-24 x .62

Model 693

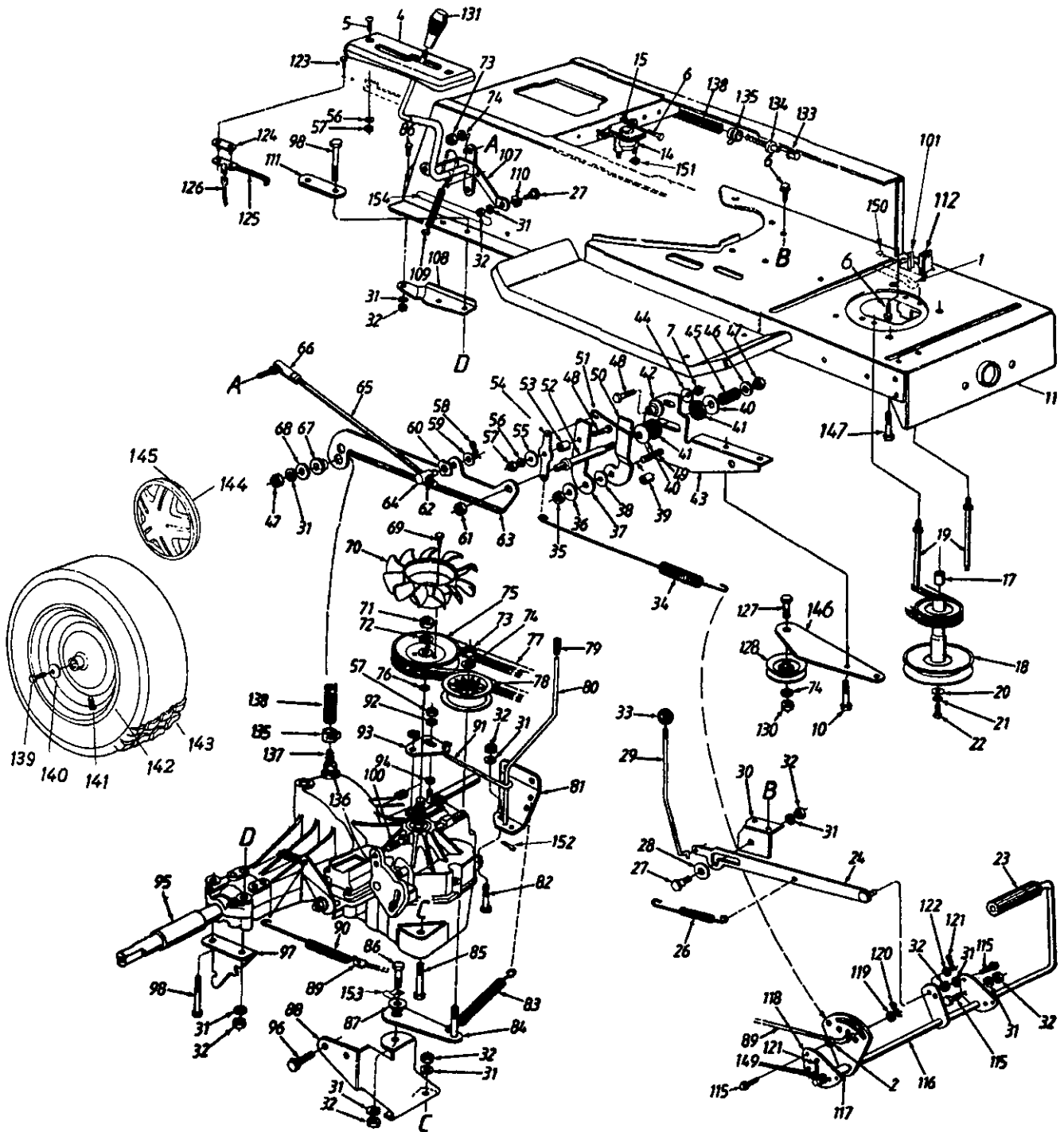

IMPORTANT: For a proper working machine, use Factory Approved Parts.
V-BELTS are specially designed to engage and disengage safely. A substitute (non OEM) V-belt can be dangerous by not disengaging completely.

Model 693

REF. NO.	PART NO.	DESCRIPTION	REF. NO.	PART NO.	DESCRIPTION
1	732-0750A	Spring Switch	64	711-0832	Ferrule 3/8-24 Thd.
2	712-0265	Hex Sems Nut 5/16-18 Thd.	65	747-0365	Control Rod
4	731-1734	Index Bracket	66	723-0351	Ball Joint 3/8-24 Thd.
5	710-0924	Pan Hd. Mach. Scr. 1/4-20 x .75" Lg.	67	748-0234	Shld. Spacer .5" Dia. x .27" Lg.
6	710-0599	Hex Washer TT-Tap Scr. 1/4-20 x .5"	68	736-0159	FI-Wash. .349" I.D. x .879" O.D.
7	712-0138	Hex Nut 1/4-28 Thd.	69	710-1189	Hex Tap Scr. #12 x 24 x .82 Lg.
8	736-0329	L-Wash. 1/4" I.D.*	70	731-1449	Fan
10	710-0642	Hex. Bolt 1/4-20 x .75" Lg.	71	712-0333	Hex Nut 1/2-20 Thd.
11	783-0310C	Lower Frame Ass'y.	72	736-0921	L-Wash. 1/2" I.D.*
14	725-1426	Solenoid	73	712-0241	Hex Nut 3/8-24 Thd.
15	736-0222	Ext. L-Wash. 1/4" I.D.	74	736-0169	L-Wash. 3/8" I.D.
17	750-0956	Spacer	75	756-0975	Transmission Pulley
18	756-0983	Engine Pulley	76	732-0729	Wire Ring
19	711-1044	Belt Guard Stud 4.75" Lg.	77	754-0441	"V"-Belt
20	736-0322	FI-Wash. 7/16" I.D. x 1.25" O.D.	78	756-0981	FI-Idler Pulley 2.75" O.D.
21	736-0171	L-Wash. 7/16" I.D.*	79	720-0238	Rod End Grip
22	710-3029	Hex Bolt 7/16-20 x 1.25" Lg.	80	747-0894	Bypass Control Lever
23	735-0196	Foot Pad	81	783-0085	Transaxle Support Brkt.-L.H.
24	683-0049	Brake Lockout Brkt. Ass'y.	82	710-0528	Hex Bolt 5/16-18 x 1.25" Lg.
26	732-0728	Foot Pedal Return Spring	83	732-0384	Ext. Spring 6.12
27	738-0296	Shld. Bolt .437" Dia. x .268"	84	683-0051	Idler Brkt. Ass'y.
28	736-0406	FI-Wash. 7/16" I.D. x 1-3/8" O.D.	85	710-0395	Hex Bolt 5/16-18 x 2.25" Lg.*
29	747-0608A	Lock-up Rod	86	710-0376	Hex Bolt 5/16-18 x 1.00" Lg.*
30	17755A	Bracket	87	748-0234	Shld. Spacer .5" Dia. x .27" Lg.
31	736-0119	L-Wash. 5/16" I.D.*	88	783-0086A	Transaxle Support Brkt.-R.H.
32	712-3010	Hex Nut 5/16-18 Thd.*	89	747-0886	Brake Rod 24.94" Lg.
33	720-0166	Ball Knob	90	732-0716	Ext. Spring
34	732-0727	Neutral Return Spring	91	747-0893	Bypass Actuator Rod
35	712-0273	Hex Nut 5/16-24 Thd.	92	736-0142	FI-Wash. .281" I.D. x .5" O.D.
36	736-3078	FI-Wash. .565 I.D. x 1.12 O.D. x .06	93	783-0098	Bypass Adjustment Brkt.
37	783-0092	Scissor-Flat	94	736-0222	External L-Wash. 1/4" I.D.
38	736-0414	FI-Wash. .33" I.D. x 1.25" O.D.	95	731-1086A	Sleeve .758" I.D. x 1" O.D.
39	750-0808	Spacer	96	710-0604	Hex. TT-Tap Scr. 5/16-18 x .62"
40	736-0219	Bell-Wash. .4" I.D. x 1.13" O.D.	97	17994	Retainer Brkt.-Transaxle
41	761-0196	Friction Washer	98	710-0176	Hex Bolt 5/16-18 x 2.75" Lg.
42	750-0918	Centering Gauge Spacer	100	710-0888	Hex Bolt 5/16-24 x 1" Lg. (Special)
43	783-0095	Neutral Return Mtg. Brkt.	101	710-0224	Hex Wash. Hd. AB-Tap Scr. #10 x .5" Lg.
44	736-0270	Bell-Wash. .265" I.D. x .75" O.D.	107	647-0008A	Speed Control Lever Ass'y.
45	732-0718	Comp. Spring 1.19" Lg.	108	17668	Axle Support Brkt.-R.H.
46	736-3008	FI-Washer .344 I.D. x .750 O.D. X .120		17669	Axle Support Brkt.-L.H. (Not Shown)
47	712-3057	Hex Nut 5/16-24 Thd.	109	732-0433	Ext. Spring 2.75" Lg.
48	710-0299	Hex Bolt 1/4-28 x 1" Lg. (Gr. 5)	110	736-0141	Spr-Wash. .445" I.D. x .75" O.D.
49	710-1012	Rib Neck Bolt 5/16-24 x .84" Lg.	111	17840	Transaxle Mtg. Brkt.
50	783-0093	Scissor-Offset	112	725-1657A	Safety Switch (Clutch)
51	747-0887	Neutral Return Rod	115	710-1238	Hex Hd. Wash. 5/16-18 x .875"
52	738-0879	Friction Disc Stud	116	683-0123	Clutch/Brake Pedal Ass'y.
53	748-0368	Shld. Spacer	117	750-0802	Spacer .63" I.D.
54	783-0096	Neutral Return Lever	118	17860	Pedal Bracket
55	736-3092	FI-Wash. .265" I.D. x 1" O.D.	119	736-3008	FI-Wash. .344" I.D. x .75" O.D.
56	736-0329	L-Wash. 1/4" I.D.*	120	714-0111	Cotter Pin 3/32" Dia.
57	712-0271	Hex Nut 1/4-20 Thd.*	121	714-0470	Cotter Pin 1/8" Dia.
58	714-0104	Hairpin Clip	122	736-0140	FI-Wash. .385" I.D. x .62" O.D.
59	736-0185	FI-Washer .406" I.D. x .750" O.D. X .63	123	710-0227	Hex AB-Tap Scr. #8 x .5" Lg.
60	736-0413	Spring Wash. .39" I.D.	124	726-0320	Insulator Nut Plate
61	712-0116	Hex L-Nut 3/8-24 Thd.	125	725-1713	Spring Switch
62	712-0711	Hex Jam Nut 3/8-24 Thd.	126	725-1399	Extension Wire
63	783-0090A	Neutral Return Brkt.	127	710-0520	Hex Bolt 3/8-16 x 1.5" Lg.

REF. NO.	PART NO.	DESCRIPTION	REF. NO.	PART NO.	DESCRIPTION
128	756-0116	Idler Pulley	141	734-0255	Air Valve
129	736-0280	Fl-Wash. .39" I.D.	142	634-0070	Rim Only
130	712-3017	Hex Nut 3/8-16 Thd.*	143	734-1675	Wheel Ass'y. Comp.
131	720-0218	Shift Knob	-	734-1596	Tire Only
133	731-1481	Vent Cap	146	783-0099	Idler Bracket
134	731-1480	Plastic Vent	147	710-1315	Hex TT-Tap Scr. 3/8-16 x 1.25"
135	726-0324	Clamp	149	736-0256	Fl. Wash. .635 x .930
136	721-0330	"O"-Ring	150	17962	Switch Plate
137	731-1485	Hose Fitting	151	712-0271	Nut 1/4-20
138	751-0588-20	Fuel Line 20" Lg.	152	714-0124	Cotter Pin
139	710-0627	Hex Bolt 5/16-24 x .75" Lg.	153	726-0272	Clamp
140	736-0242	Bell-Wash. .345" I.D. x .88" O.D.	154	783-0122	Reinforcement Bracket

Model 693

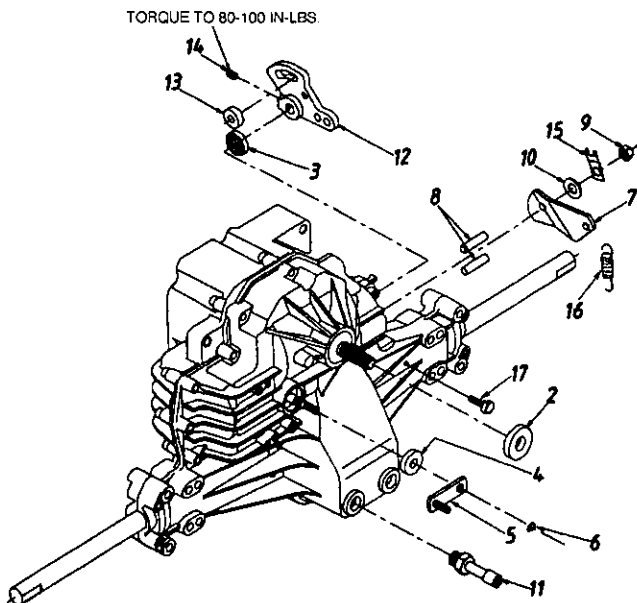

REF. NO.	PART NO.	DESCRIPTION
1	718-0255A	Transmission Comp.
2	HG-9008000-0128	Seal—Lip
3	HG-9008000-0126	Seal—Lip
4	HG-45074	Seal—Lip 10X25X7
5	HG-50126	Arm—Bypass
6	HG-44870	Ring—Retaining
7	HG-44094	Arm—Actuating
8	HG-44891	Pin—Actuating
9	HG-50108	Nut—Hex Lock 5/16-24 UNJC
10	HG-44130	Washer 7/16" x 7/8" x .06"
11	HG-50042	Breather Ass'y.
12	HG-45007	Arm—Control
13	HG-50034	Puck—Dampener
14	HG-50018	Set Screw
15	HG-50129	Strap, Locking
16	HG-50384	Spring, Extension
17	HG-50653	Self Tapp. Scr. #10-.325 x .5"

Model 693

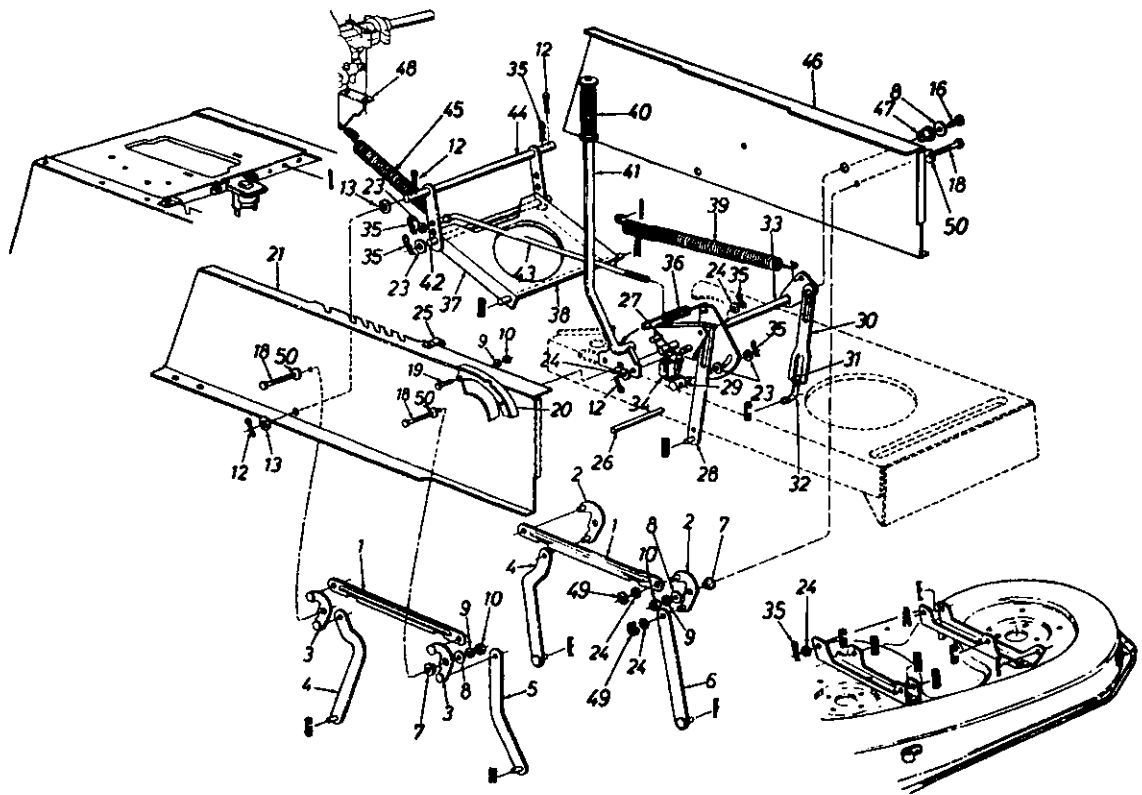

REF. NO.	PART NO.	DESCRIPTION	REF. NO.	PART NO.	DESCRIPTION
1	783-0103	Connecting Rod	29	711-0723A	Adj. Ferrule 3/8-24 Thd.
2	683-0029A	Pivot Link Ass'y.—L.H.	30	17712	Adj. Deck Lift Link
3	683-0028A	Pivot Link Ass'y.—R.H.	31	712-3066	Hex Nut 1/2-20 Thd. (Gr. 5)
4	17710	Deck Hanger Link Ass'y.	32	711-0841	Lift Link Adjuster
5	14800A	Deck Hanger Link Ass'y.	33	683-0059	Lift Shaft Ass'y.
6	14804A	Deck Hanger Link Ass'y.	34	725-1657	Safety Switch (Deck)
7	748-0331	Shld. Spacer .318" I.D.	35	714-0145	Inter. Cotter Pin 3/8" Dia.
8	736-0264	Fl-Wash. .344" I.D. x .62" O.D.	36	732-0637	Extension Spring
9	736-0119	L-Wash. 5/16" I.D.*	37	17636C	Stabilizer Bracket
10	712-3010	Hex Nut 5/16-18 Thd. (Gr. 5)	38	738-0670	Shaft 1/2" Dia. x 10.28" Lg.
12	714-0470	Cotter Pin 1/8" Dia.	39	732-0638	Extension Spring
13	736-0256	Fl-Wash. .635" I.D. x 1.0" O.D.	40	720-0233	Grip (Lift Handle)
16	710-0604	Hex Wash. TT-Tap Scr. 5/16-18 x .75" Lg.	41	97675A	Deck Lift Handle Ass'y.
18	710-1238	Hex Wash. Hd. Scr. 5/16-18 x .875" Lg.	42	738-0669	Shaft 3/8" Dia. x 9.34" Lg.
19	710-3008	Hex Bolt 5/16-18 x .75" Lg.	43	747-0598	Disengagement Rod
20	783-0118	Index Brkt.	44	97624	Stabilizer Shaft Ass'y.
21	783-0042B	Upper Frame—R.H.	45	732-0556	Extension Spring 7.58" Lg.
23	736-0267	Fl-Wash. .385" I.D. x .87" O.D.	46	783-0043	Upper Frame—L.H.
24	736-0160	Fl-Wash. .531" I.D. x .93" O.D.	47	741-0313	Flange Brg. .632" I.D.
25	726-0272	Clamp	48	17128A	Spring Retainer Brkt.
26	738-0526	Running Board Rod	49	716-0104	"E"-Ring
27	710-3007	Hex Wash. Hd. Tap Scr.	50	736-0425	Bell-Wash. .325" I.D.
28	14802A	Link Deck Lift Ass'y.			

Model 693

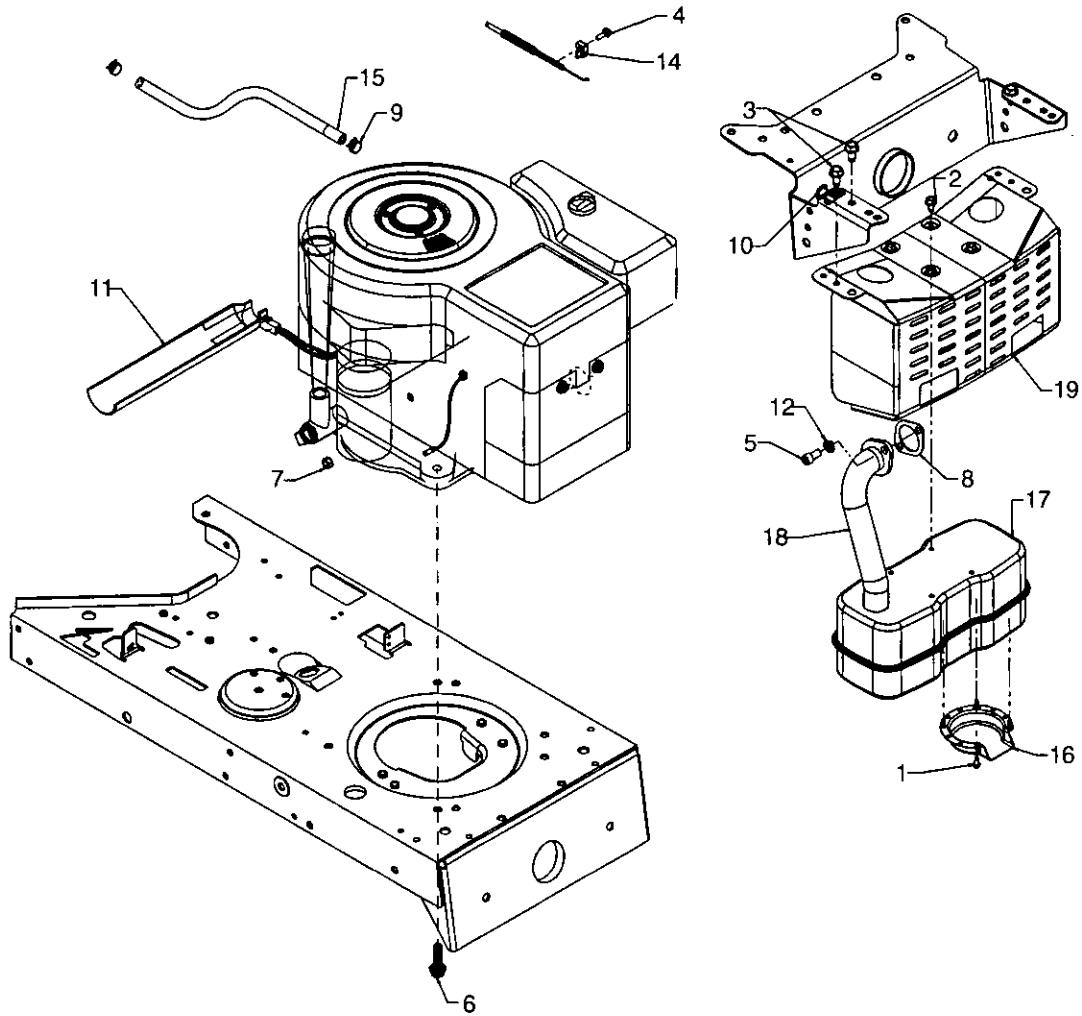

REF. NO.	PART NO.	DESCRIPTION	REF. NO.	PART NO.	DESCRIPTION
1	710-0148	Hex Slot Scr. #8-32 x .38" Lg.	10	726-0272	Clamp 9/16 Dia.
2	710-0599	Hex Wash. TT-Tap Scr. 1/4-20 x .5" Lg.	11	731-1682A	Oil Drain Sleeve
3	710-0604	Hex Wash Hd. TT-Tap Scr. 5/16-18 x .62"	12	736-0119	L-Wash. 5/16" I.D.*
4	710-1237	Scr. #10-32:.620 Hx. Slot Wash.	14	751B213146	Casing Clamp, Throttle, B&S
5	710-1314	Socket Hd. Bolt 5/16-18 x .62" Lg.	15	751-0535-13	Fuel Line Hose
6	710-1315	Scr. 3/8-16 x 1.25	16	751-0564	Muffler Deflector
7	712-0271	Nut, Hex 1/4-20	17	751-0617	Muffler
8	721-0208	Exhaust Gasket	18	751-0619	Exhaust Pipe
9	726-0205	Hose Clamp .49 Dia.	19	783-0615	Muffler Heat Shield

Model 693

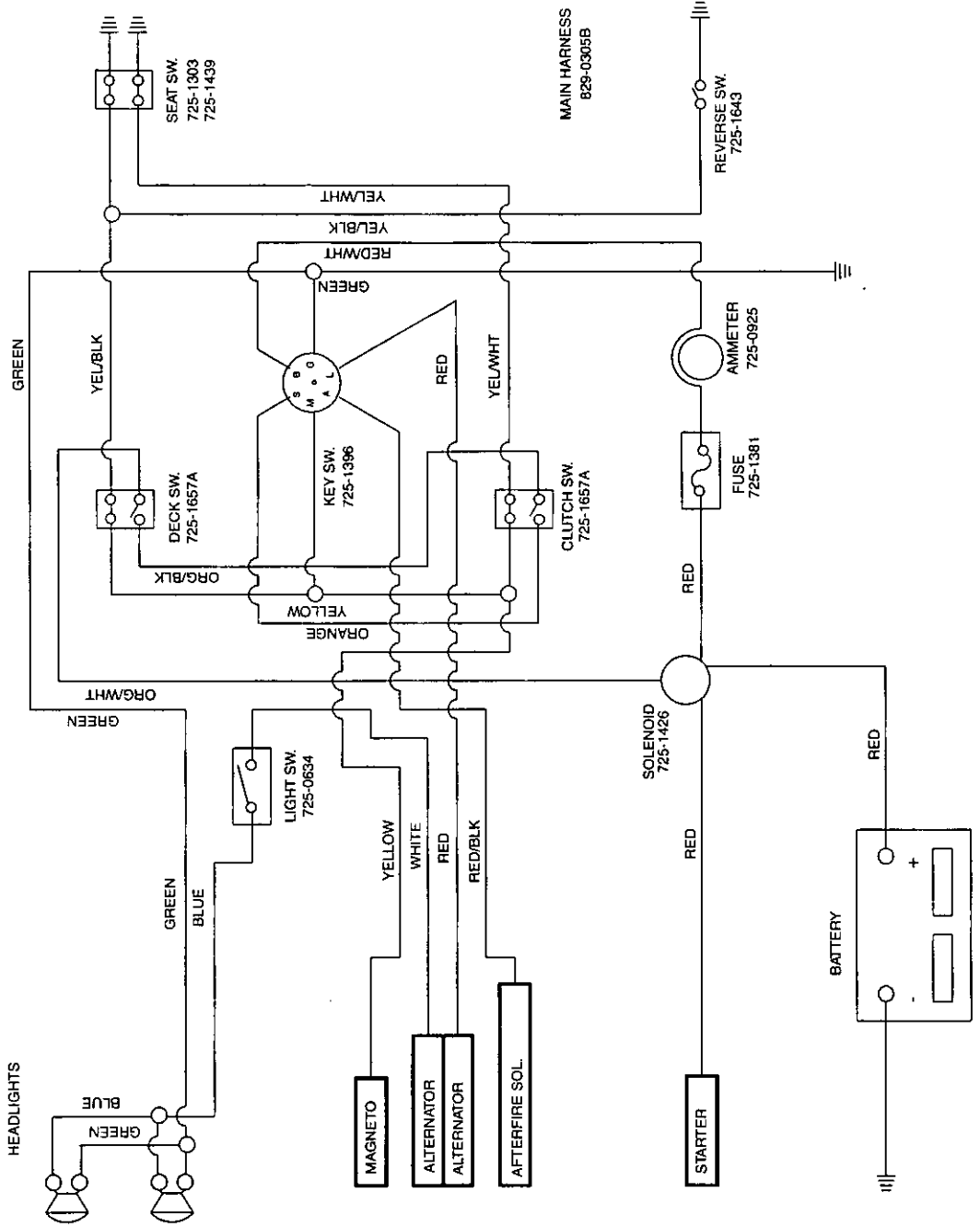

Notes

-

-

-

-

-

Notes

-

-

-

-

-

-

MANUFACTURER'S LIMITED WARRANTY FOR:



For TWO YEARS from the date of retail purchase within the United States of America, its possessions and territories, White Outdoor Products Company will, at its option, repair or replace, for the original purchaser, free of charge, any part or parts found to be defective in material or workmanship. This warranty covers units which have been operated and maintained in accordance with the operating instructions furnished with the unit, and which have not been subject to misuse, abuse, neglect, accident, improper maintenance or alteration.

NORMAL WEAR PARTS or components thereof are subject to separate terms as noted below in the "No Fault Ninety Day Consumer Warranty" clause. Commercial use is subject to the terms listed above, and is covered for a period of 90 days from the date of purchase.

TWO YEAR CONSUMER WARRANTY ON NORMAL WEAR PARTS WITH NINETY DAY NO FAULT PROTECTION: All normal wear parts failures will be covered on this product for a period of 90 days regardless of cause. After 90 days, but within the two year period, normal wear parts failures will be covered if caused by defects in material or workmanship. Normal wear parts are defined as belts, blades, blade adapters, grass bags, rider deck wheels, seats, snow thrower skid shoes, shave plates and tires.

HOW TO OBTAIN SERVICE: Warranty service is available, with proof of purchase, through your local authorized service dealer. To locate the dealer in your area, please check the yellow pages or contact the Customer Service Department of White Outdoor Products Company, P O Box 361131, Cleveland, Ohio 44136-0019. Phone (330) 225-8883. The return of a complete unit will not be accepted by the factory unless prior written permission has been extended by the Service Department of White Outdoor Products Company.

TRANSPORTATION CHARGES: Transportation charges for the movement of any power equipment unit or attachment are the responsibility of the purchaser. Transportation charges for any parts submitted for replacement under this warranty must be paid by the purchaser unless such return is requested by White Outdoor Products Company.

UNITS EXPORTED OUT OF THE UNITED STATES: White Outdoor Products Company does not extend any warranty for products sold or exported outside of the United States of America, its possessions and territories, except those sold through White Outdoor Products Company's authorized channels of export distribution.

OTHER WARRANTIES:

1. The engine or component parts thereof carry separate warranties from their manufacturers. Please refer to the applicable manufacturer's warranty on these items.
2. Batteries are covered by a 90-day replacement warranty.
3. Log splitter pumps, valves and cylinders or component parts thereof are covered by a one year warranty.
4. All other warranties, express or implied, including any implied warranty of merchantability or fitness for a particular purpose, are hereby expressly disclaimed in their entirety.
5. The provisions as set forth in this warranty provide the sole and exclusive remedy of White Outdoor Products Company's obligations arising from the sales of its products. White Outdoor Products Company will not be liable for incidental or consequential loss or damage.

HOW STATE LAW RELATES TO THIS WARRANTY: This limited warranty gives you specific legal rights, and you may also have other rights which vary from state to state. Certain disclaimers are not allowed in some states and therefore they may not apply to you under all circumstances.

NOTE: This warranty does not cover set-up, routine maintenance items such as lubricants, filters, blade sharpening and tune-ups, or adjustments such as brake adjustments. Nor does this warranty cover normal deterioration of the exterior finish due to use or exposure.