

WHITE

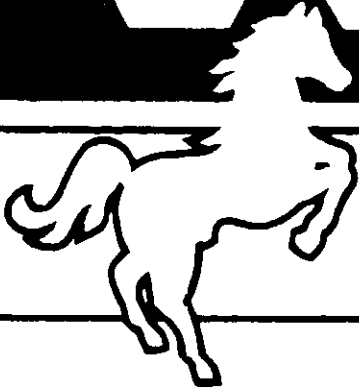

OUTDOOR PRODUCTS OWNER'S GUIDE

LAWN BOSS 21" ROTARY MOWER

Model No.
118-434R190

Thank you for purchasing
an American-built product.

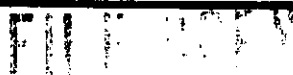

INDEX

Slope Gauge	3
Contents of Hardware Pack	4
Rules for Safe Operation	5
Assembly	6
Controls	11
Operation	12
Adjustments	13
Lubrication	14
Maintenance	14
Off-Season Storage	15
Trouble Shooting Chart	17
Illustrated Parts	18
Repair Parts List	19

Dear Customer,

So often throughout the year we are all in a rush to meet our daily obligations.

However, we at White Outdoor Products are taking a quick moment out to say

“Thank you for your business.”

Sincerely,

WHITE OUTDOOR PRODUCTS



INSTRUCTIONS GIVEN WITH THIS SYMBOL ARE FOR PERSONAL SAFETY. BE SURE TO FOLLOW THEM.

LIMITED WARRANTY

For two years from the date of original retail purchase, WHITE OUTDOOR PRODUCTS will either repair or replace, at its option, free of charge, F.O.B. factory or authorized service firm, any part or parts found to be defective in material or workmanship. Transportation charges for the movement of any power equipment unit or attachment are the responsibility of the purchaser. Transportation charges for any parts submitted for replacement under this warranty must be paid by the purchaser unless such return is requested by WHITE OUTDOOR PRODUCTS.

This warranty will not apply to any part which has become inoperative due to misuse, excessive use, accident, neglect, improper maintenance, alterations, or unless the unit has been operated and maintained in accordance with the instructions furnished. This warranty does not apply to the engine, motor, battery, battery charger or component parts thereof. Please refer to the applicable manufacturer's warranty on these items.

Warranty on units used commercially is limited to sixty (60) days.

Warranty service is available through your local authorized service dealer or distributor. If you do not know the dealer or distributor in your area, please write to the Customer Service Department of WHITE OUTDOOR PRODUCTS.

The return of a complete unit will not be accepted by the factory unless prior written permission has been extended by WHITE OUTDOOR PRODUCTS.

This warranty gives you specific legal rights. You may also have other rights which vary from state to state.

WARNING: This unit is equipped with an internal combustion engine and should not be used on or near any unimproved forest-covered, brush-covered or grass-covered land unless the engine's exhaust system is equipped with a spark arrester meeting applicable local or state laws (if any). If a spark arrester is used, it should be maintained in effective working order by the operator.

In the State of California the above is required by law (Section 4442 of the California Public Resources Code). Other states may have similar laws. Federal laws apply on federal lands. A spark arrester for the muffler is available through your nearest engine authorized service center.

--Cut Along This Line--

USE THIS SHEET AS A GUIDE TO DETERMINE SLOPES WHERE YOU MAY NOT OPERATE SAFELY.

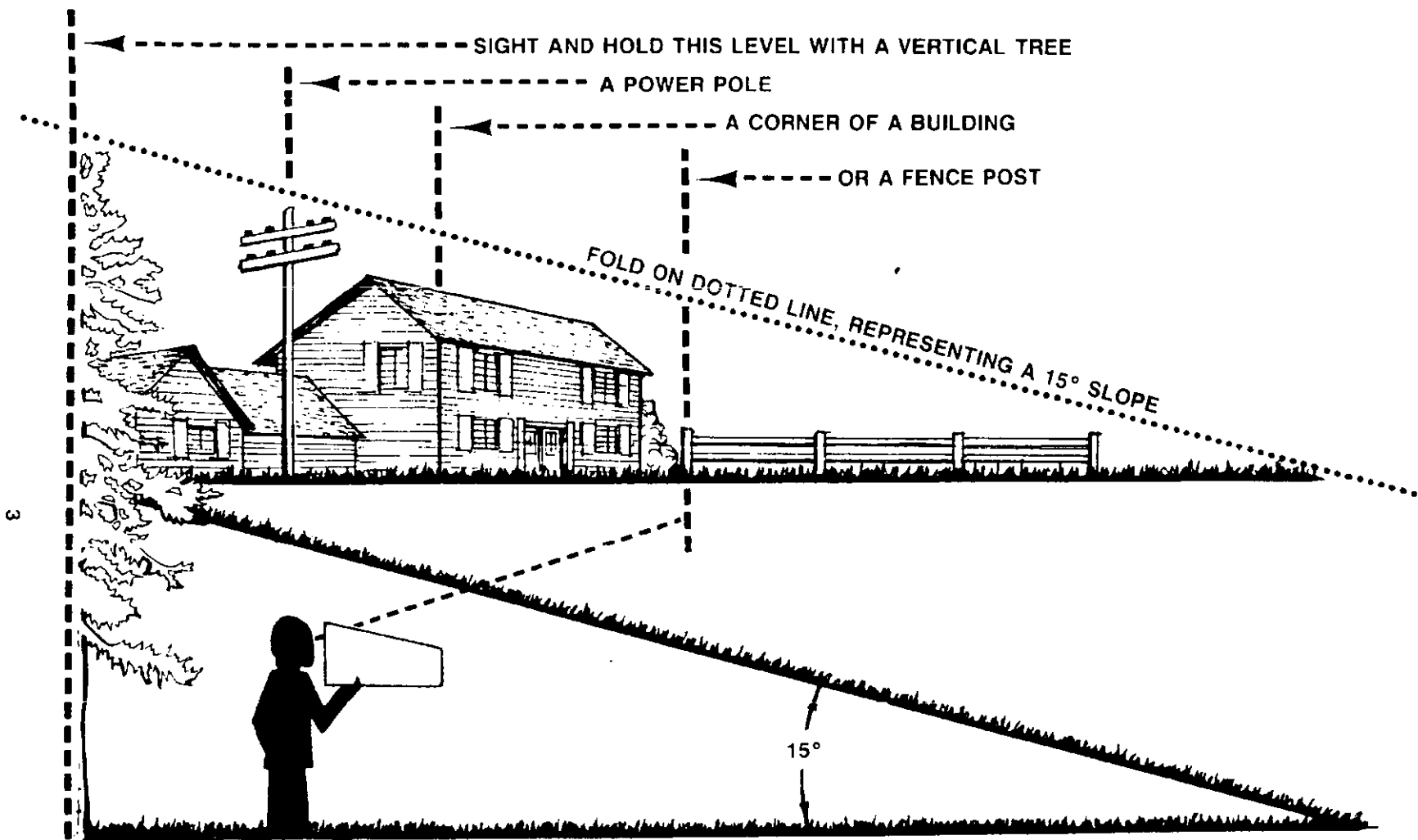

(Keep this sheet in a safe place for future reference.)

SLOPE GAUGE



WARNING

Do not mow on inclines with a slope in excess of 15 degrees (a rise of approximately 2½ feet every 10 feet). A riding mower could overturn and cause serious injury. If operating a walk-behind mower on such a slope, it is extremely difficult to maintain your footing and you could slip, resulting in serious injury.

Operate RIDING mowers up and down slopes, never across the face of slopes.

Operate WALK-BEHIND mowers across the face of slopes, never up and down slopes.

CONTENTS OF HARDWARE PACK/PARTS IDENTIFICATION

Remove this sheet from your owner's manual and lay the hardware on the illustration for identification purposes. After assembly, keep the Slope Gauge which is on the reverse side of this sheet for future use.
(Hardware pack may contain extra items which are not used on your unit.)

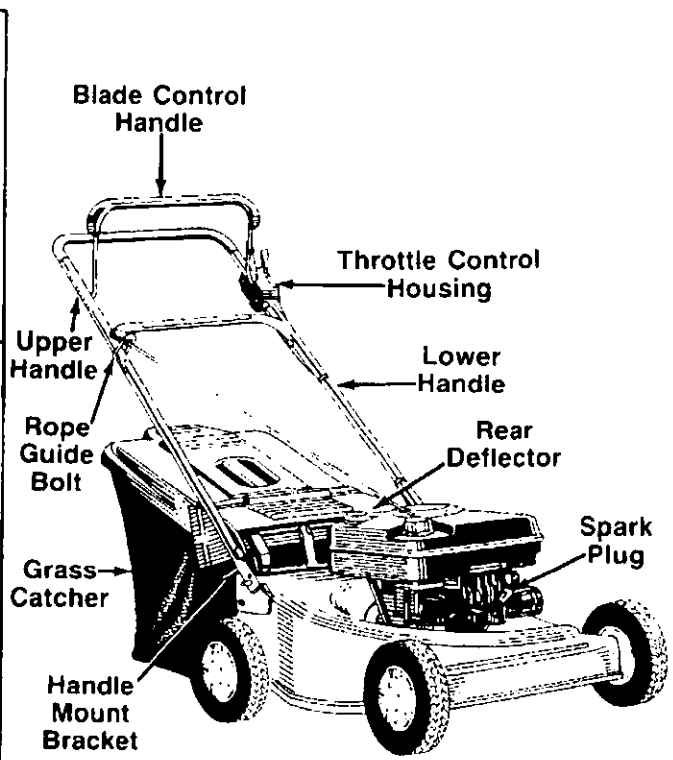
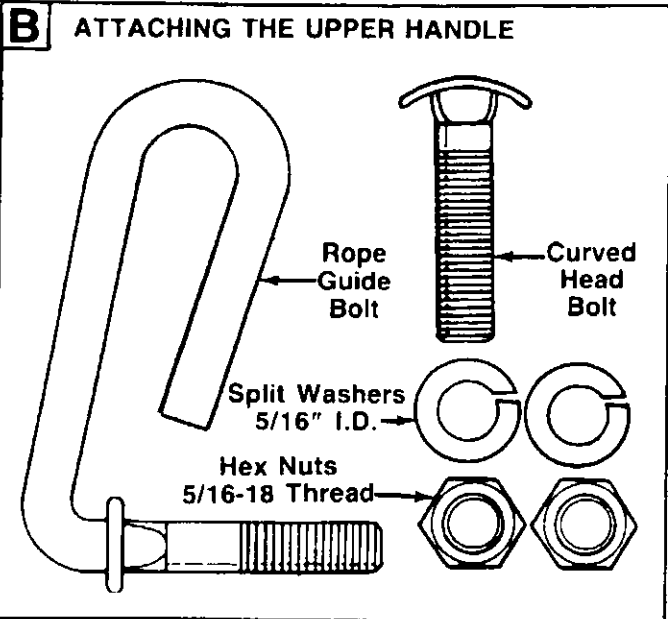
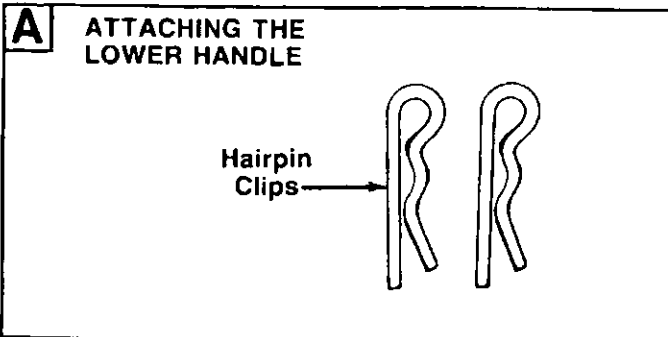

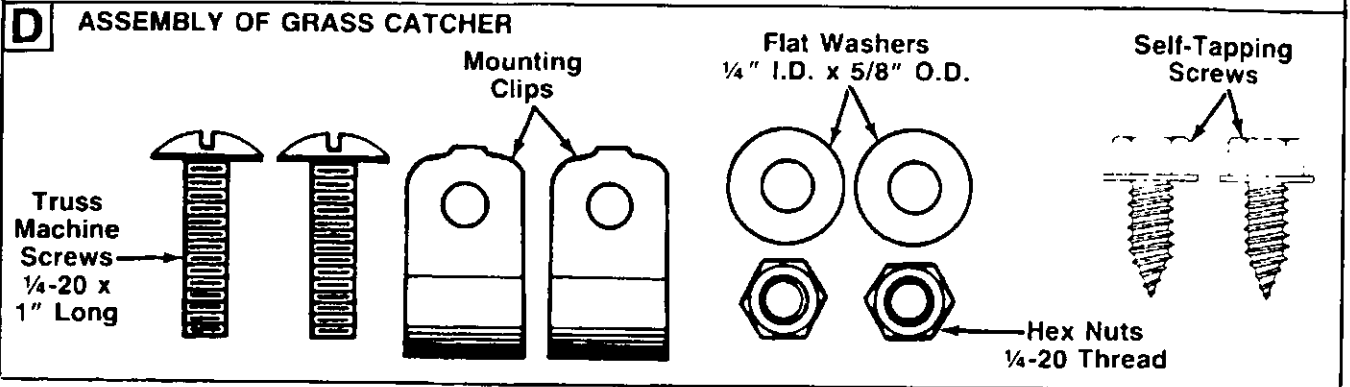
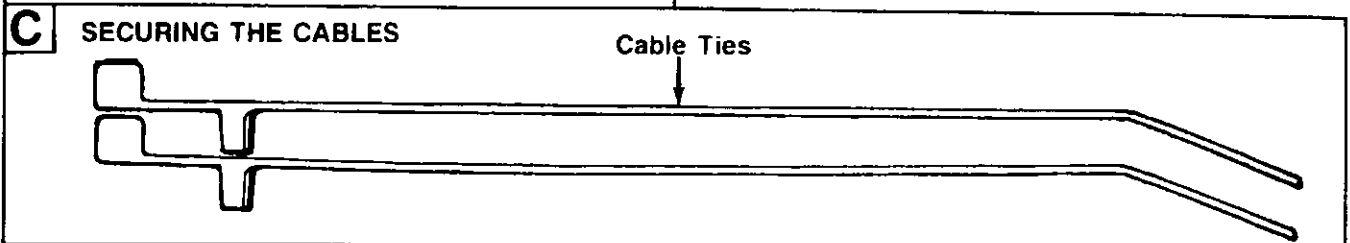

(Model 435R Shown)

PARTS IDENTIFICATION



IMPORTANT

RULES FOR SAFE OPERATION

 THIS SYMBOL POINTS OUT IMPORTANT SAFETY INSTRUCTIONS WHICH, IF NOT FOLLOWED, COULD ENDANGER THE PERSONAL SAFETY AND/OR PROPERTY OF YOURSELF AND OTHERS. READ AND FOLLOW ALL INSTRUCTIONS IN THIS MANUAL BEFORE ATTEMPTING TO OPERATE YOUR LAWN MOWER. FAILURE TO COMPLY WITH THESE INSTRUCTIONS MAY RESULT IN PERSONAL INJURY. WHEN YOU SEE THIS SYMBOL--  HEED ITS WARNING 



Your lawn mower was built to be operated according to the rules for safe operation in this manual. As with any type of power equipment, carelessness or error on the part of the operator can result in serious injury. If you violate any of these rules, you may cause serious injury to yourself or others.

TRAINING

1. Read this owner's manual carefully in its entirety before attempting to assemble or operate this machine. Be completely familiar with the controls and the proper use of this machine before operating it. Keep this manual in a safe place for future and regular reference and for ordering replacement parts.
2. Your rotary mower is a precision piece of power equipment, not a plaything. Therefore, exercise extreme caution at all times.
3. Never allow children to operate a power mower. Only persons well acquainted with these rules of safe operation should be allowed to use your mower.
4. Keep the area of operation clear of all persons, particularly small children and pets. Stop engine when they are in the vicinity of your mower to help prevent blade contact or thrown object injury. Although the area of operation should be completely cleared of foreign objects, an object may have been overlooked and could be accidentally thrown by the mower in any direction and cause serious personal injury to the operator or any other allowed in the area.

PREPARATION

1. Thoroughly inspect the area where the equipment is to be used. Remove all stones, sticks, wire, bones and other foreign objects which could be picked up and thrown by the mower in any direction and cause serious personal injury to the operator or any others allowed in the area.
2. Always wear safety glasses or eye shields during operation or while performing an adjustment or repair, to protect eyes from foreign objects that may be thrown from the machine in any direction.
3. Wear sturdy, rough-soled work shoes and close-fitting slacks and shirts to avoid entanglement in the moving parts. Never operate a unit in bare feet, sandals or sneakers.
4. Check the fuel before starting the engine. Gasoline is an extremely flammable fuel. Do not fill the gasoline tank indoors while the engine is running or until engine has been allowed to cool for two minutes after running. Replace gasoline cap securely and wipe off any spilled gasoline before starting the engine as it may cause a fire or explosion.
5. Disengage the self-propelled mechanism or drive clutch on units so equipped before starting the engine.
6. The blade control handle is a safety device. Never attempt to bypass its operation. Doing so makes the safety device inoperative and may result in personal injury through contact with the rotating blade. The blade control handle must operate easily in both directions.
7. Never attempt to make a wheel or cutting height adjustment while the engine is running.
8. Never operate the equipment in wet grass. Always be sure of your footing. A slip and fall can cause serious personal injury. Keep a firm hold on the handle and walk, never run. Mow only in daylight or in good artificial light.

9. For your safety, use the slope gauge included as part of this manual to measure slopes before operating this unit on a sloped or hilly area. If the slope is greater than 15° as shown on the slope gauge, do not operate this unit on that area or serious injury could result.

OPERATION

1. Do not change the engine governor settings or overspeed the engine. Excessive engine speeds are dangerous.
2. Do not put hands or feet near or under rotating parts. Keep clear of the discharge opening at all times as the rotating blade can cause injury.
3. Stop the blade when crossing gravel drives, walks or roads.
4. After striking a foreign object, stop the engine, remove the wire from the spark plug, and thoroughly inspect the mower for any damage. Repair the damage before restarting and operating the mower.
5. If the equipment should start to vibrate abnormally, stop the engine and check immediately for the cause. Vibration is generally a warning of trouble.
6. Shut the engine off and wait until the blade comes to a complete stop before removing the grass catcher or unclogging the chute. The cutting blade continues to rotate for a few seconds after the engine is shut off. Never place any part of the body in the blade area until you are sure the blade has stopped rotating.
7. Before cleaning, repairing or inspecting, make certain the blade and all moving parts have stopped. Disconnect the spark plug wire, and keep the wire away from the spark plug to prevent accidental starting.
8. Do not run the engine indoors.
9. Mow across the face of slopes, never up-and-down. Exercise extreme caution when changing direction on slopes. Do not mow excessively steep slopes. Always be sure of your footing. A slip and fall can cause serious personal injury.
10. Never operate mower without proper guards, plates or other safety protective devices in place.
11. Do not operate this mower with the chute door open, unless the complete grass catcher is properly mounted on the mower.

MAINTENANCE AND STORAGE

1. Check the blade and engine mounting bolts at frequent intervals for proper tightness.
2. Keep all nuts, bolts, and screws tight to be sure the equipment is in safe working condition.
3. Never store the equipment with gasoline in the tank inside of a building where fumes may reach an open flame or spark. Allow the engine to cool before storing in any enclosure.
4. To reduce fire hazard, keep the engine free of grass, leaves, or excessive grease.
5. Check the grass catcher bag frequently for wear or deterioration. For safety protection, replace only with new bag meeting original equipment specifications.

IMPORTANT: This unit is shipped **WITHOUT GASOLINE** or **OIL**. After assembly, service engine with gasoline and oil as instructed in the separate engine manual packed with your unit.

NOTE: Reference to right or left hand side of the mower is observed from the operating position. Refer to parts identification on page 4 for location of parts when assembling the mower.

ASSEMBLY INSTRUCTIONS

Tools Required for Assembly

- (1) Pair of Pliers
- (1) 1/2" Wrench*
- (1) 5/16" Wrench or Nutdriver*
- (1) Screwdriver
- *Or one 6" Adjustable Wrench.

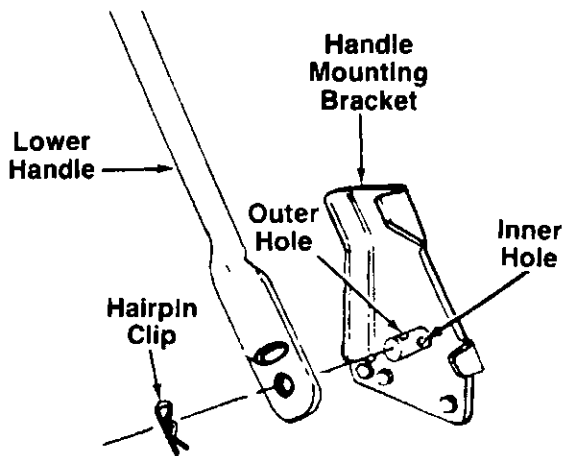

FIGURE 1.

UNPACKING

1. Remove the lawn mower from the carton by opening the top flaps and lifting the unit out. Be careful of the staples. Make certain all parts and literature have been removed from the carton before the carton is discarded.
2. Disconnect and ground the spark plug wire against the engine. Check beneath the deck for any cardboard packaging. Remove if present.
3. Stretch out all control cables and place on the floor. Be careful not to bend or kink the cables at any time during assembly.
4. Remove page four from this manual and lay the contents of the hardware pack on the illustration for identification.

ATTACHING THE LOWER HANDLE (Hardware A)

1. Attach the lower handle by placing the bottom holes in the lower handle over the weld pins on the handle mounting brackets on the rear of the deck. Make certain the instruction label on the lower handle can be read from the operating position.
2. Using a pair of pliers, squeeze one leg of the lower handle against the handle mounting bracket. Insert the hairpin clip into the inner hole on the weld pin. See figure 1. Repeat on other side.

NOTE

There are two (2) holes in the handle mounting brackets. Place the hairpin clip in the inner hole for operation. Outer hole is for storage.

ATTACHING THE UPPER HANDLE (Hardware B)

1. Place the upper handle in position over the lower handle. **The label on the throttle control housing and the control lever must be facing up.**

NOTE

The right hand side of the handle will be secured with the rope guide bolt. However, left handed operators may assemble the rope guide bolt to the left side of the handle for easier starting by following steps 2 and 3 and reversing the left and right hand instructions.

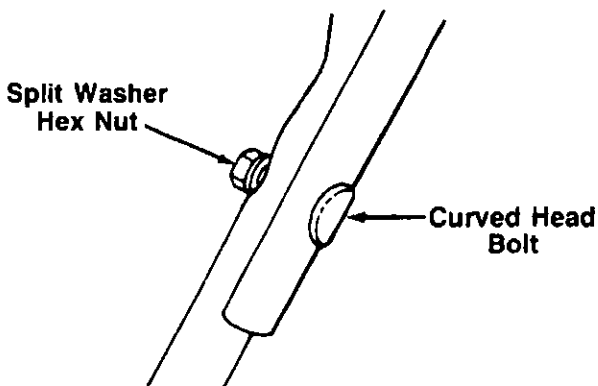

FIGURE 2.

2. Secure the left hand side of upper handle using the curved head bolt, split washer and hex nut as shown in figure 2.

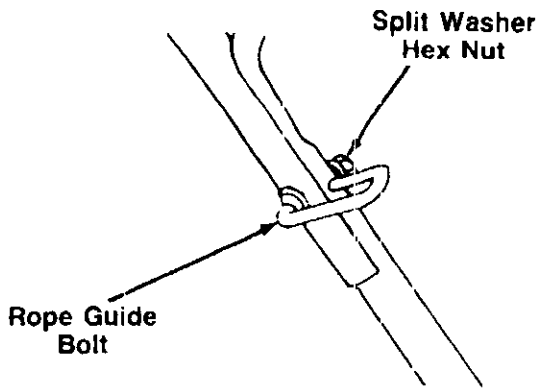

FIGURE 3.

3. Insert the rope guide bolt through the right hand side of upper and lower handle. See figure 3. Secure with split washer and hex nut, finger tight only.

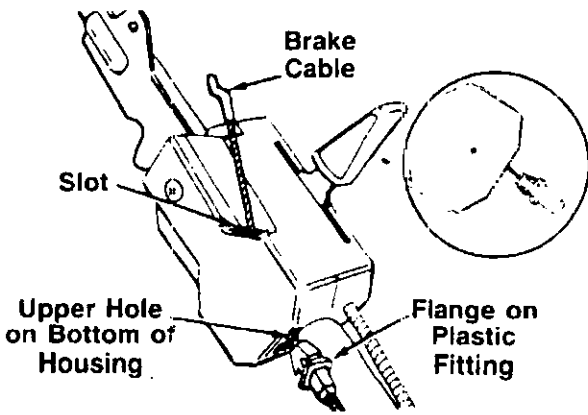

FIGURE 4.

ATTACHING THE BRAKE CABLE

1. The brake cable is attached to the engine, and has a "Z" fitting on the loose end. Route the brake cable below the lower handle. Place end of cable into the upper hole on the bottom of the control housing, and through the slot as shown. The angle of the plastic flange must be positioned downward as shown in figure 4. Be careful not to bend or kink the cable at any time.
2. Push the plastic fitting until it locks into the control housing.



Brake cable must be assembled as shown for proper blade brake operation.

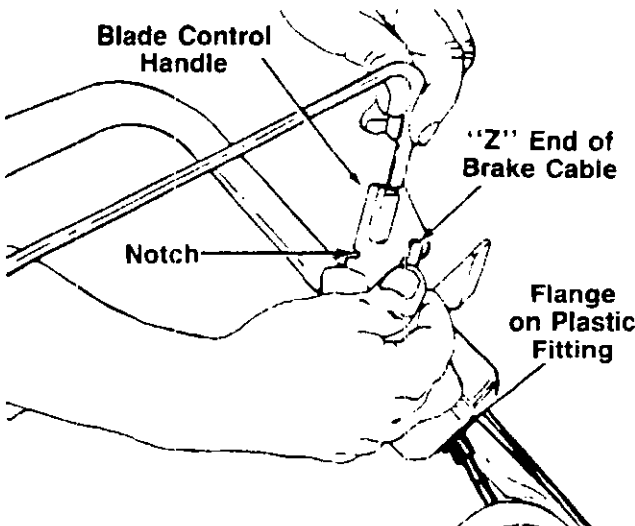

FIGURE 5.

3. Hook the "Z" end of the brake cable into the hole in the blade control handle from the inside to the outside as shown in figure 5.

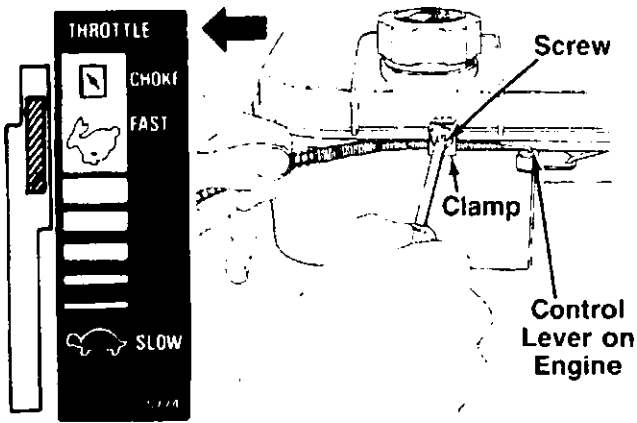

FIGURE 6A.—Model 434R

ATTACHING THE THROTTLE CABLE

Model 434R Only:

1. Push the throttle control lever on the handle all the way forward to CHOKE, then back it off two "clicks" (approximately 5/16"). See figure 6A.
2. The throttle control cable is attached to the upper handle. Route the throttle control cable under the lower handle and inside the handle mounting bracket. Hook the "Z" end of the throttle control cable into the hole in the control lever on the engine. See figure 6A.
3. Using a screwdriver, remove the screw on the cable clamp shown in figure 6A. Slip the control cable under the clamp. Replace the screw, but do not tighten (cable must still move freely beneath the clamp).
4. Push the control lever on the engine as far toward the rear of the engine as it will go. See figure 6A. Pull the throttle control cable toward the rear of the engine to remove any slack in the cable as you tighten the screw.

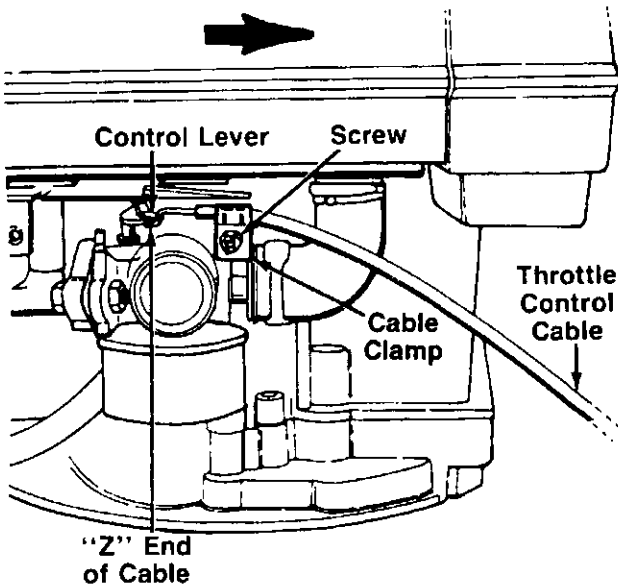

FIGURE 6B.—Models 435R and 438R

ATTACHING THE THROTTLE CABLE

Models 435R and 438R Only:

1. Place the throttle control lever on the handle in FAST position.
2. The throttle control cable is attached to the upper handle. Route the throttle control cable under the lower handle and inside the handle mounting bracket. Hook the "Z" end of the throttle control cable into the control lever on the engine as shown in figure 6B.
3. Loosen (do not remove) the screw on the cable clamp shown in figure 6B. Slip the control casing under the clamp (cable must move freely beneath the clamp).
4. Place the control lever on the engine in the full open position by pushing it as far toward the rear of the unit as it will go. Tighten the screw on the cable clamp to secure the cable in this position.

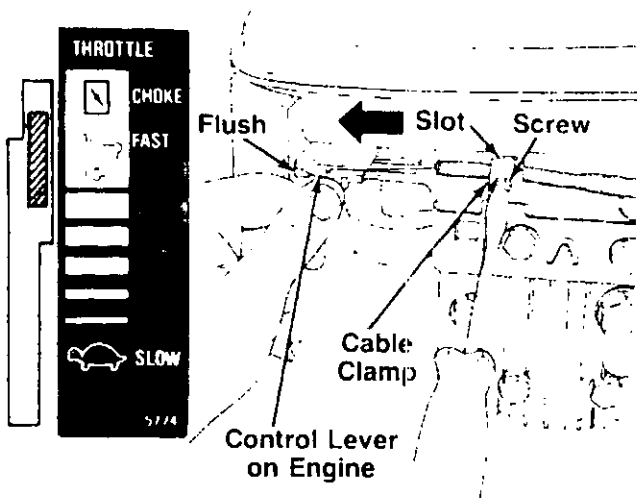

FIGURE 6C.—Models 436R and 439R

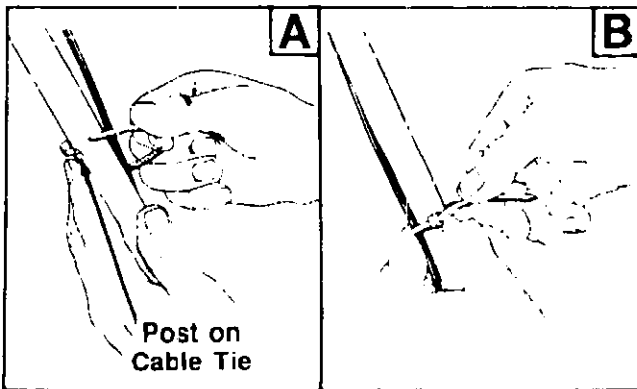

FIGURE 7.

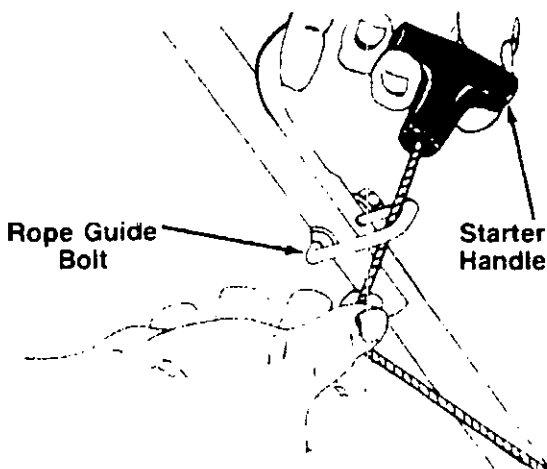

FIGURE 8.

ATTACHING THE THROTTLE CABLE

Models 436R and 439R Only:

1. Push the throttle control lever on the handle all the way forward to CHOKE, then back it off **two "clicks"** (approximately 5/16"). See figure 6C.
2. The throttle control cable is attached to the upper handle. Route the throttle control cable under the lower handle and inside the handle mounting bracket. Hook the "Z" end of the throttle control cable into the hole in the control lever on the engine. See figure 6C.
3. Using a 5/16" wrench or nutdriver, remove the screw on the cable clamp shown in figure 6C. Slip the control cable under the clamp. Replace the screw (cable should be above the screw), but do not tighten (cable must still move freely beneath the clamp). Make certain the tab on the cable clamp is seated into the slot on the engine.
4. Push the control lever on the engine as far toward the **outside** of the engine as it will go. The edge of the control lever should be flush with the bracket on the engine. See figure 6C. Hold the control lever in this position as you tighten the screw on the cable clamp to secure the throttle cable.
5. Loosen the screw on the clamp on the side of the engine. Slip the cable casing under the clamp to secure the cable **away from the muffler**. Be careful not to bend or kink the cable. Tighten the screw.

SECURING THE CABLES (Hardware C)

Secure all cables to the left side of the handle as follows.

- A. Insert posts on cable ties into holes provided on the lower handle. The holes may be either on the inside or outside of the handles. See figure 7A.
- E. Secure the cables with the cable ties. See figure 7B.
- C. Trim excess ends of cable ties.

ATTACHING THE STARTER ROPE

1. The starter rope is protruding from the top of the engine. Additional rope may be wound around the starter handle. If so, unwind the rope from the handle.
2. With the spark plug wire disconnected and grounded, depress the blade control handle and pull the rope out of the engine.
3. Slip the starter rope into the rope guide bolt as shown in figure 8
4. Tighten the hex nut on the rope guide bolt securely.

FINAL ASSEMBLY OF MOWER

1. Attach hub caps (optional) to the wheels by lining up the tabs on the hub caps with the holes in the wheels. Push to lock in position.
2. Make certain **all** nuts and bolts are tightened securely.

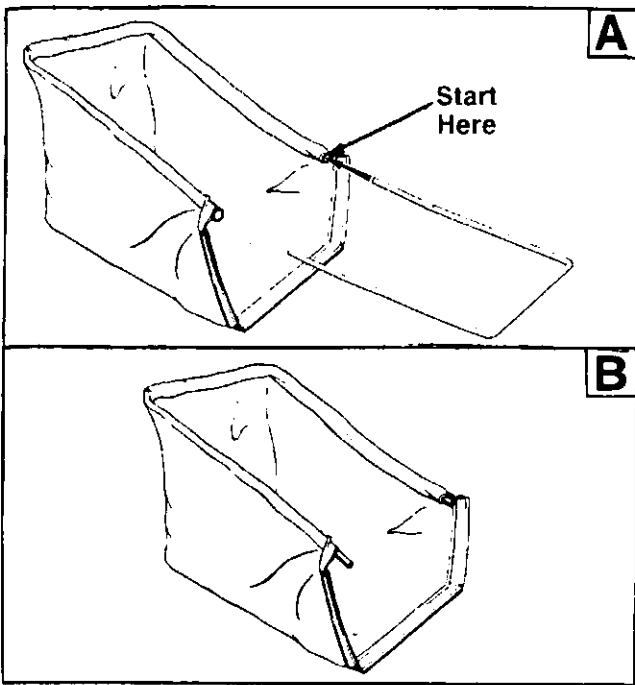

FIGURE 9.

ASSEMBLY OF GRASS CATCHER (Hardware D)

1. Insert one end of the rear frame into the cloth channel on the edge of the grass catcher bag. Feed all the material on one side of the frame before working it around the frame. See figure 9.

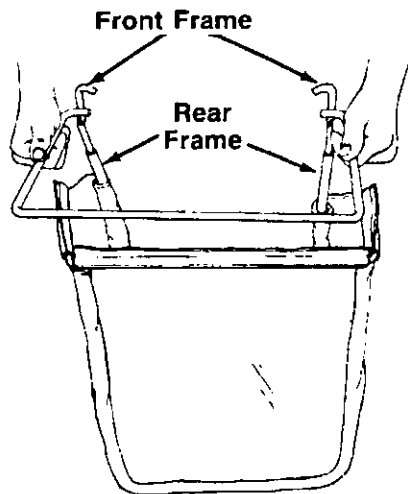

FIGURE 10.

2. Slide the ends of the front frame assembly into the ends of the rear frame as shown in figure 10.

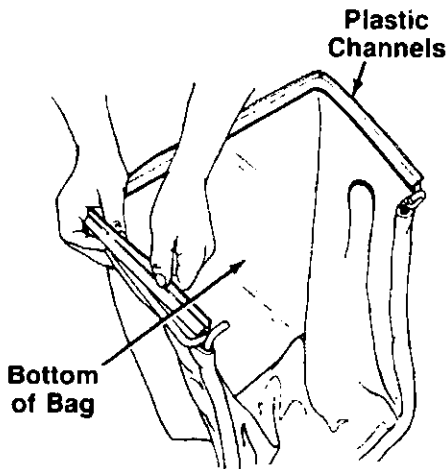

FIGURE 11.

3. Secure front of bag to front frame by slipping plastic channels on sides and bottom of bag over frame. See figure 11.

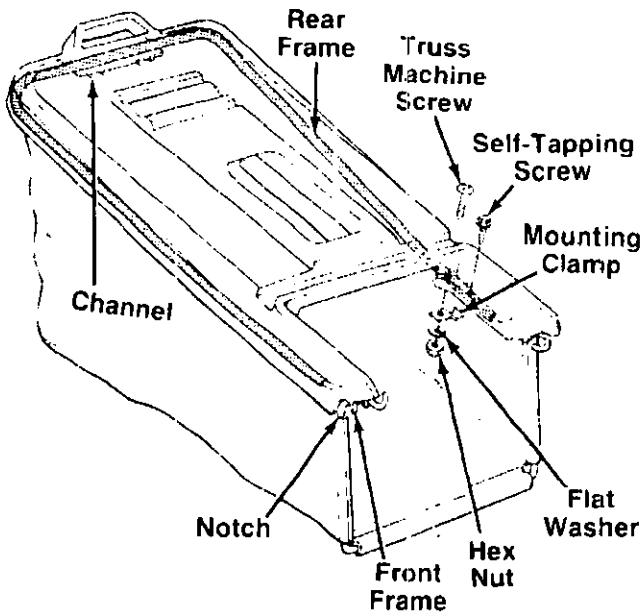

FIGURE 12.

4. Attach the hardtop cover to the grass catcher as follows. See figure 12.
 - a. Place the cover in position on top of the grass catcher. Press the rear frame into the channel on the rear of the cover (beneath the rear handle).
 - b. Slide the notches on the sides of the cover over the front catcher frame
 - c. Place truss machine screw down through hole in cover. Place mounting clip over truss machine screw, with the cupped part of the mounting clip beneath the frame of the grass catcher. Secure with flat washer and hex nut. Repeat on other side of grass catcher
 - d. Attach cover to frame using self-tapping screws as shown in figure 12.

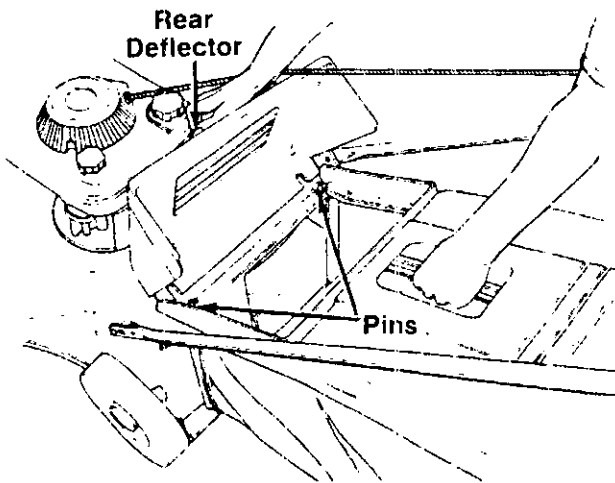

FIGURE 13.

ATTACHING BAG TO MOWER

Lift the rear deflector on the mower. Place the hooks on the grass catcher over the pins on the back of the mower. See figure 13. Release the rear deflector.

To remove the grass catcher, lift the rear deflector on the mower. Lift the grass catcher up, over the pins on the back of the mower. Release the rear deflector.

CONTROLS

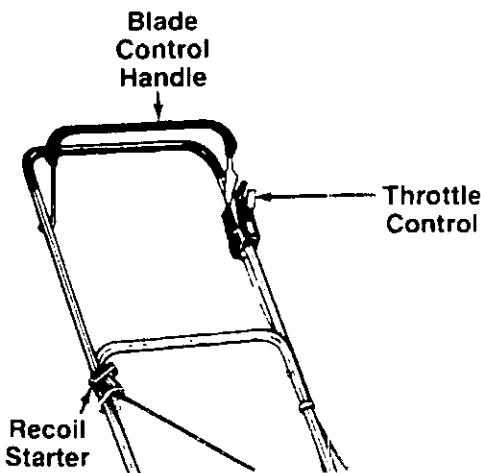

FIGURE 14.

BLADE CONTROL HANDLE

WARNING
THIS CONTROL MECHANISM IS A
SAFETY DEVICE NEVER ATTEMPT
TO BYPASS ITS OPERATIONS

The blade control handle is located on the upper handle of the mower. See figure 14. The blade control handle must be depressed in order to operate the unit. Release the blade control handle to stop the engine and blade.



The blade will be rotating whenever the engine is running

THROTTLE CONTROL

The throttle control is located on the left side of the upper handle. It is used to regulate the engine speed.



The throttle control cannot be used to stop the engine.

RECOIL STARTER

The recoil starter handle is attached to the handle. See figure 14. Stand behind the unit in the operating position to start the unit.

OPERATION



FIGURE 15.

Keep hands and feet away from the chute area on cutting deck. See figure 15.

NOTE

For shipping purposes your mower is set with the wheels in a low cutting height position. For best results raise the cutting position until it is determined which height is best for your lawn. See cutting height adjustment section.

GAS AND OIL FILL-UP

Service the engine with gasoline and oil as instructed in the separate engine manual packed with your mower. Read instructions carefully.



Never fill fuel tank indoors, with engine running or until the engine has been allowed to cool for at least two minutes after running.

TO START ENGINE AND ENGAGE BLADE

1. Attach spark plug wire to spark plug. If unit is equipped with a rubber boot over the end of the spark plug wire, make certain the metal loop on the end of the spark plug wire (inside the rubber boot) is fastened securely over the metal tip on the spark plug. See figure 16.

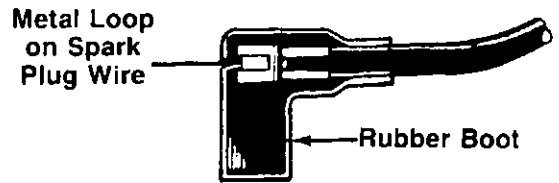

FIGURE 16.

2. Models 434R, 436R and 439R only: Open fuel shut-off valve. See figure 17.

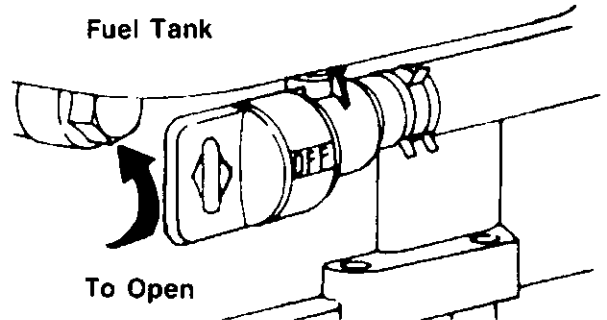

FIGURE 17A.—Models 436R and 439R

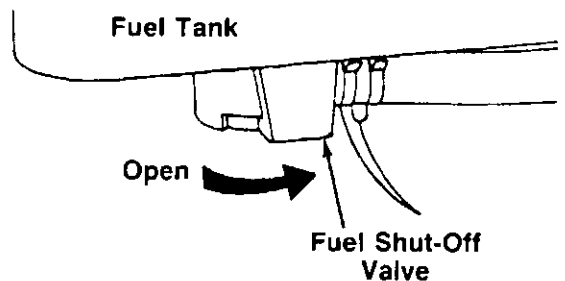

FIGURE 17B.—Model 434R

3. Models 434R, 436R and 439R: Move throttle control lever to CHOKE position.

Models 435R and 438R: Move the throttle control lever to FAST or START position.

4. **Models 435R and 438R only:** Prime engine as instructed in the separate engine manual packed with your unit.
5. Standing behind the unit, depress the blade control handle and hold it against the upper handle as shown. See figure 18.
6. Grasp the recoil starter handle and pull back rapidly, extending rope fully. Return it slowly to the rope guide bolt.
7. After engine starts, move throttle control to desired engine speed.

NOTE

If any problems are encountered refer to the Trouble Shooting Chart on page 17.

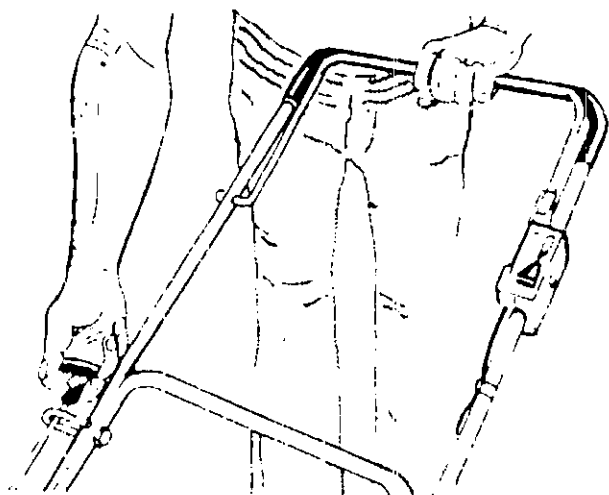

FIGURE 18.

TO STOP ENGINE AND BLADE

1. Release the blade control handle to stop the engine and blade.



The blade continues to rotate for a few seconds after the engine is shut off.

2. Disconnect the spark plug wire and ground it against the engine to prevent accidental starting while equipment is unattended.

USING YOUR ROTARY MOWER



Never operate your unit without either the rear deflector or entire grass catcher assembly in place.

Be sure that lawn is clear of stones, sticks, wire, or other objects which could damage lawn mower or engine. Such objects could be accidentally thrown by the mower in any direction and cause serious personal injury to the operator and others.

Operate a new engine at intermediate speeds and light load for the first few hours as you would a new automotive engine.

For the best results, do not cut wet grass because it tends to stick to the underside of the mower, preventing proper discharge of grass clippings, and could cause you to slip and fall. New grass, thick grass or wet grass may require a narrower cut. Blade speed should be adjusted to the condition of the lawn.

For best results cut off one-third or less of the total length of the grass. Lawn should be cut in the fall as long as there is growth.

This mower is designed to be operated at full throttle to give you the best cut and do the most effective job of bagging the cut grass.

IMPORTANT

If you strike a foreign object, stop the engine. Remove wire from spark plug, thoroughly inspect the mower for any damage, and repair the damage before restarting and operating the mower. Extensive vibration of the mower during operation is an indication of damage. The unit should be promptly inspected and repaired.

ADJUSTMENTS



Do not at any time make any adjustment to lawn mower without first stopping engine and disconnecting spark plug wire.

CUTTING HEIGHT ADJUSTMENT

The height adjustment handle is located on the left side of the deck. The handle may be placed in one of nine cutting height positions. Push the handle to the left and then either forward to lower the cutting height or backward to raise the cutting height. See figure 19.

For rough or uneven lawns, move the height adjustment handle to a position which will give a higher cutting height.

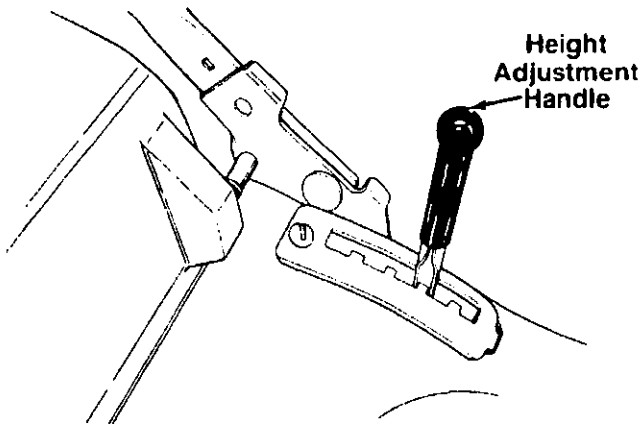

FIGURE 19.

THROTTLE

The throttle control wire assembly can be adjusted if necessary. Loosen the screw on the cable clamp shown in figure 6. Adjust as instructed in steps 1 and 4 of "Attaching the Throttle Control Cable" in Assembly Instructions.

CARBURETOR ADJUSTMENTS



WARNING

If any adjustments are made to the engine while the engine is running (e.g. carburetor), keep clear of all moving parts. Be careful of heated surfaces and muffler.

Minor carburetor adjustments may be required to compensate for differences in fuel, temperature, altitude and load. To adjust carburetor, refer to the separate engine manual packed with your mower.

NOTE

A dirty air cleaner will cause an engine to run rough. Be certain air cleaner is clean and attached to the carburetor before adjusting carburetor. Refer to the separate engine manual.

LUBRICATION



WARNING

Always stop engine and disconnect spark plug wire before cleaning, lubricating or doing any kind of work on lawn mower.

Blade Control—Lubricate the pivot points on the blade control handle and the brake cable at least once a season with light oil. See figure 20. The blade control must operate freely in both directions.

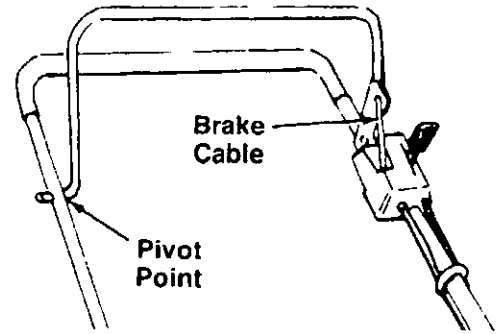

FIGURE 20.

Discharge Chute Deflector—The torsion spring and pivot point should be lubricated periodically with light oil to prevent any rust or binding. Deflector must work freely.

Wheels—Mower may be provided with ball bearing wheels. Lubricate at least once a season with light oil. Also, if the wheels are removed for any reason, lubricate the surface of the axle bolt and the inner surface of the wheel with light oil. A 4 oz. plastic bottle of light oil lubricant is available. Order part number 737-0170. Engine oil may also be used.

Engine—Follow engine manual for lubrication instructions.

Throttle—Periodically lubricate throttle control lever and throttle wire assembly with a few drops of light oil for ease of operation.

MAINTENANCE



WARNING

Be sure to disconnect and ground the spark plug wire before performing any repairs or maintenance.

NOTE

When tipping the unit, empty the fuel tank and keep engine spark plug side up.

TROUBLE SHOOTING

Refer to page 17 of this manual for trouble shooting information.

CUTTING BLADE

When removing the cutting blade for sharpening or replacement protect hands by using heavy gloves or a rag to grasp the cutting blade. Remove the bolt and blade bell washer which hold the blade and adapter to the engine crankshaft. Remove the blade and adapter from the crankshaft.



CAUTION

Periodically inspect the blade adapter for cracks, especially if you strike a foreign object. Replace when necessary.

When sharpening the blade, follow the original angle of grind as a guide. It is **extremely important** that each cutting edge receives an equal amount of grinding to prevent an unbalanced blade. An unbalanced blade will cause excessive vibration when rotating at high speeds, may cause damage to the mower and could break, causing personal injury.

The blade can be tested by balancing it on a round shaft screwdriver. Remove metal from the heavy side until it balances evenly.

Before reassembling the blade and the blade adapter to the unit, lubricate the engine crankshaft, the inner surface of the blade adapter and the center bolt with light oil. A 4 oz. plastic bottle of light oil lubricant is available. Order part number, 737-C170. Engine oil may also be used.

When replacing the blade, be sure to install the blade with the side of the blade marked "Bottom" (or with part number) facing the ground when the mower is in the operating position.

Blade Mounting Torque

Center Bolt 375 in. lb. min., 450 in. lb. max.

To insure safe operation of your unit, **all** nuts and bolts must be checked periodically for correct tightness.

DECK

The underside of mower deck should be cleaned after each period of use as grass clippings, leaves, dirt and other matter will accumulate. This accumulation of grass clippings, etc., is undesirable as it will invite rust and corrosion and may cause an uneven discharge of grass clippings at the next cutting.

The deck may be cleaned by tilting the mower and scraping clean with a suitable tool or by washing with a stream of water from a garden hose.



NOTE

Do not direct the stream of water at a hot engine as damage to the engine may result.

ENGINE

Refer to the separate engine manual for all engine maintenance instructions.

Maintain **engine oil** as instructed in the separate engine manual packed with your unit. Read and follow its instructions carefully.

Service **air cleaner** every 25 hours under normal conditions. Clean every few hours under extremely dusty conditions. Poor engine performance and flooding usually indicates that the air cleaner should be serviced. To service the air cleaner, refer to the separate engine manual packed with your unit.

The **spark plug** should be cleaned and the gap reset once a season. Spark plug replacement is recommended at the start of each mowing season; check engine manual for correct plug type and gap specifications.

Clean the engine regularly with a cloth or brush. Keep the cooling system (blower housing area) clean to permit proper air circulation which is essential to engine performance and life. Be certain to remove all grass, dirt and combustible debris from muffler area.

OFF-SEASON STORAGE

The following steps should be taken to prepare lawn mower for storage.

1. Clean and lubricate mower thoroughly as described in the lubrication instructions.
2. Refer to engine manual for correct engine storage instructions
3. Coat mower's cutting blade with chassis grease to prevent rusting.
4. Store mower in a dry, clean area.



NOTE

When storing any type of power equipment in an unventilated or metal storage shed, care should be taken to rustproof the equipment. Using a light oil or silicone, coat the equipment, especially cables and all moving parts.

HANDLE STORAGE

The handle may be placed in an upright position for storage. Move hairpin clips to outer hole on weld pins. See figure 1. Press inward on the bottom of the lower handle and push forward. The handle will lock in this position.

To place the handle in the operating position, remove the starter rope from the rope guide bolt. Grasp the lower handle at the bottom, press inward slightly and tip the handle backward. Place the hairpin clips in the inner holes. With the spark plug wire disconnected and grounded, depress the blade control handle and pull the starter rope out from the engine. Slip the starter rope into the rope guide bolt.

NOTE

The use of any accessory on this Rotary Mower other than those manufactured by the mower manufacturer is **not** recommended.



WARNING

1. DO NOT operate the mower without the entire grass catcher or chute deflector in place.
2. DO NOT operate the mower without the protective shield on the rear of the deck in place.

NOTE

Under normal usage bag material is subject to wear and should be checked periodically. Be sure any replacement bag complies with the mower manufacturer's recommendations.

For replacement bags, use only factory authorized replacement bag, part number 764-0252.

Trouble Shooting Chart

Symptom	Possible Causes	Corrective Action
1 Engine fails to start	<p>A Blade control handle disengaged</p> <p>B Check fuel tank for fuel</p> <p>C Fuel shut-off valve closed (on units so equipped).</p> <p>D Spark plug lead wire disconnected.</p> <p>E Throttle control lever not in the starting position</p> <p>F Faulty spark plug</p> <p>G Carburetor improperly adjusted, engine flooded</p> <p>H Old stale fuel</p> <p>I Engine brake engaged</p>	<p>A Engage blade control handle.</p> <p>B Fill tank if empty.</p> <p>C Open fuel shut-off valve.</p> <p>D Connect lead wire.</p> <p>E Move throttle lever to start position.</p> <p>F Clean, adjust gap or replace.†</p> <p>G Remove spark plug, dry the plug, crank engine with plug removed, and throttle in off position. Replace spark plug and lead wire and resume starting procedures.</p> <p>H Drain and refill with fresh fuel.</p> <p>I Follow starting procedure.</p>
2 Hard starting or loss of power	<p>A Spark plug wire loose</p> <p>B Carburetor improperly adjusted</p> <p>C Dirty air cleaner</p>	<p>A Connect and tighten spark plug wire.</p> <p>B Adjust carburetor.†</p> <p>C Clean air cleaner.†</p>
3 Operation erratic	<p>A Dirt in fuel tank</p> <p>B Dirty air cleaner</p> <p>C Water in fuel supply</p> <p>D Vent in gas cap plugged</p> <p>E Carburetor improperly adjusted</p>	<p>A Remove the dirt and fill tank with fresh fuel.</p> <p>B Clean air cleaner.†</p> <p>C Drain contaminated fuel and fill tank with fresh fuel.</p> <p>D Clear vent or replace gas cap.</p> <p>E Adjust carburetor.†</p>
4 Occasional skip (hesitates) at high speed	<p>A Carburetor idle speed too slow</p> <p>B Spark plug gap too close</p> <p>C Carburetor idle mixture adjustment improperly set</p>	<p>A Adjust carburetor.†</p> <p>B Adjust to .030".</p> <p>C Adjust carburetor.†</p>
5 Idles poorly	<p>A Spark plug fouled, faulty, or gap too wide</p> <p>B Carburetor improperly adjusted</p> <p>C Dirty air cleaner</p>	<p>A Reset gap to .030" or replace spark plug.</p> <p>B Adjust carburetor.†</p> <p>C Clean air cleaner.†</p>
6 Engine overheats	<p>A Carburetor not adjusted properly</p> <p>B Air flow restricted</p> <p>C Engine oil level low</p>	<p>A Adjust carburetor.†</p> <p>B Remove blower housing and clean.†</p> <p>C Fill crankcase with the proper oil</p>
7 Excessive vibration	<p>A Cutting blade loose or unbalanced</p> <p>B Bent cutting blade</p>	<p>A Tighten blade and adapter. Balance blade.</p> <p>B Replace blade.</p>

†Refer to separate engine manual packed with your unit.

Note: For repairs beyond the minor adjustments listed above, contact your local authorized service dealer.

Models 434R thru 439R

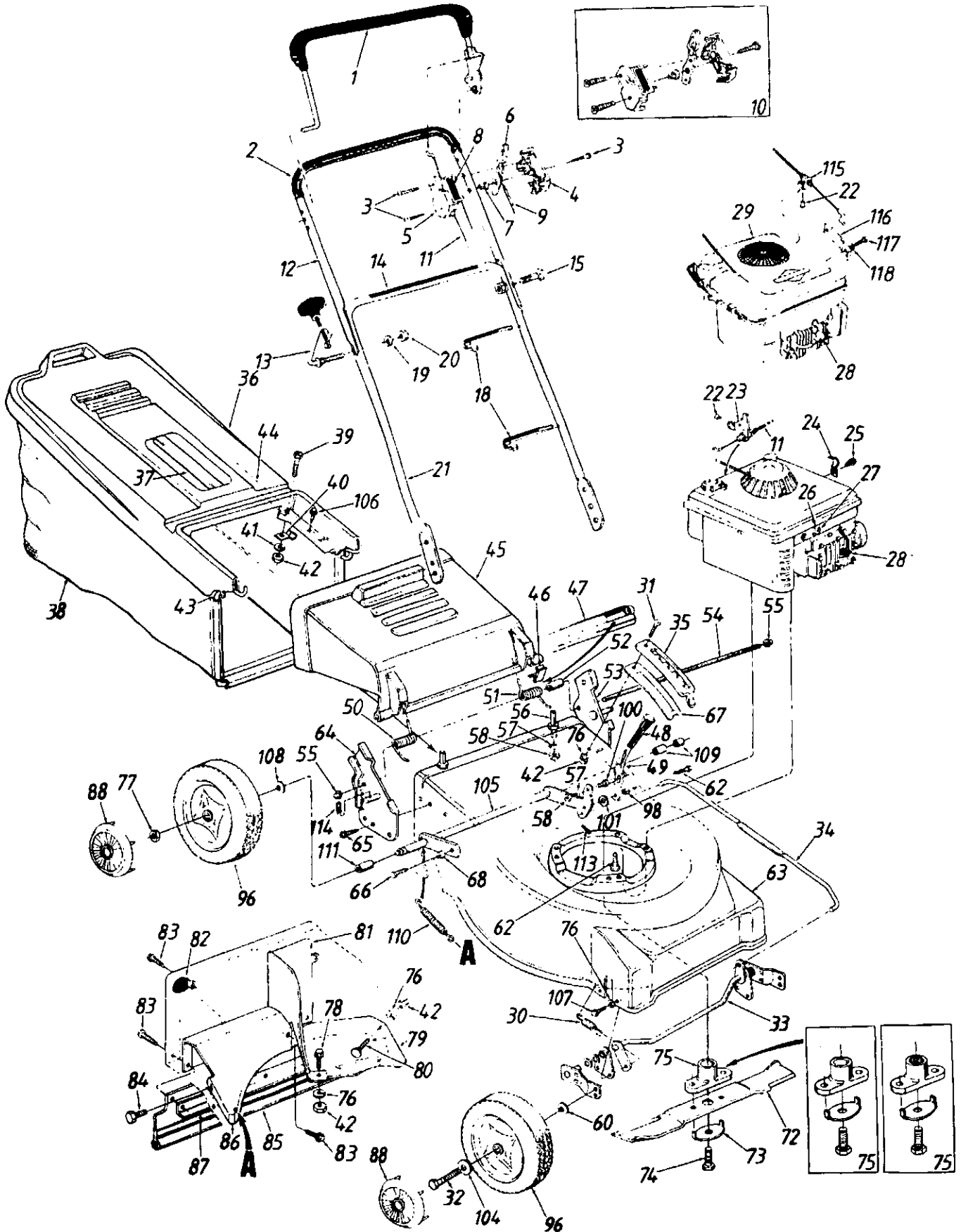

PARTS LIST FOR MODELS 434R THRU 439R ROTARY MOWERS

REF. NO.	PART NO.	COLOR CODE	DESCRIPTION	NEW PART	REF. NO.	PART NO.	COLOR CODE	DESCRIPTION	NEW PART
1	731-0609		Control Handle Ass'y.		49	732-0580		Spring Lever	
2	718-0145		Grip		50	732-0578		Torsion Spring—R.H.	N
3	710-0796		Truss Mach. B-Tap Scr #12 x 1.5" Lg.		51	732-0577		Torsion Spring—L.H.	N
4	731-0817		Control Panel Half		52	750-0566		Spacer .255" I.D.	
5	731-0816		Clutch Panel Half		53	12297		Handle Brkt. Ass'y.—L.H.	
6	731-0528		Throttle Control Lever		54	747-0698		Hinge Pin 17.75" Lg.	N
7	731-0524		Control Disc Pin		55	726-0106		Cap Speed Nut	
8	777-5774		Control Label—Throttle		56	711-0805		Shld Pin 3/8-24 x 1.43" Lg.	
9	746-0672		Throttle Wire—58" Lg. (436R, 439R)	N	57	736-0169		L-Wash. 3/8" I.D.*	
	746-0632		Throttle Wire—53" Lg. (434R)		58	712-0711		Hex Jam Nut 3/8-24 Thd.	
	746-0640		Throttle Wire—45" Lg. (435R, 438R)		60	736-0105		Bell-Wash. 38" I.D. x .88" O.D.	
10	753-0430		Control Housing Comp.		62	710-0654		Hex L-Wash. Hd. Scr. 3/8-16 x 1" Lg.	
11	746-0477		Control Cable—43" Lg. (436R, 439R)		63	16997	638	21" Deck Ass'y.	N
	746-0480		Control Cable—46" Lg. (434R)		64	12296		Handle Brkt. Ass'y.—R.H.	
	746-0479		Control Cable—55" Lg. (435R, 438R)		65	710-0892		Hex L-Wash. Hd. AB-Tap Scr. 1/4 x .62" Lg.	
12	749-0436		Upper Handle		66	710-1006		Hex Wash. Hd. Tap Scr. 3/8-16 x .75" Lg.	
13	710-0842		Rope Guide Bot		67	721-0216		Height Adjustment Support	
14	777-5776		Instruction Label—Handle		68	750-0526		Spacer .385" I.D.	
15	710-0671		Curved Carriage Bol' 5/16-18 x 1.38" Lg.		72	742-0306		21" Blade	
18	726-0240		Cable Tie		73	736-0415		Blade Bell-Wash. .44" I.D. x 2.38"	N
19	736-0119		L-Wash. 5/16" I.D.*		74	710-0459		Hex Bolt 3/8-24 x 1.5" Lg. (Used w/Keyed Adapter)	
20	712-0267		Hex Nut 5/16-18 Thd.*			710-0757		Hex Bolt 7/16-20 x 1.5" Lg. (Splined)	
21	749-0505		Lower Handle		75	753-0462		Blade Adapter Kit (Keyed)	N
22	728-0171		Pop Rivet .156" Dia. x .379" (434R, 436R, 439R)			753-0463		Blade Adapter Kit (Splined)	N
23	14924		Cable Bracket (436R, 439R)		76	736-0329		L-Wash. 1/4" I.D.*	
24	12894		Casing Clamp (436R, 439R)		77	712-0346		Hex Jam Nut 1/2-20 Thd	
25	710-0429		Hex B-Tap Scr. #10 x .38" Lg (436R, 439R)		78	710-0252		Hex Bolt 1/4-20 x .85" Lg.	
26	751-0463		Casing Clamp (436R, 439R)		79	17013		Rear Belt Baffle	N
27	710-0436		Hex B-Tap Scr. #10 x .62" Lg. (436R, 439R)		80	710-0167		Carr. Bolt 1/4-20 x .50" Lg.*	
28	735-0639		Spark Plug Boo		81	17007		Rear Panel Baffle	N
29	—		Engine		82	731-0931		Corner Plug	N
30	732-0589		Extension Spring 2.39" Lg.		83	710-1017		Torx Mach. AB-Tap Scr 1/4 x .62" Lg.	N
31	710-0946		Truss Mach. Scr 1/4-20 x .62" Lg.*		84	710-0352		Hex B-Tap Scr. 1/4 x .36" Lg	
32	**		Axle Bolt		85	731-0669		Rear Flap	N
33	17022		Front Axle Ass'y.	N	86	17008		Rear Chute Baffle	N
34	747-0699		Height Adj. Connecting Rod	N	87	14847		Retaining Strip	
35	17323		Height Adjustment Plate	N	88	**		Hub Cap	
36	731-0857		Hardtop Bag Cover	N	96	**		Wheel Ass'y. Comp.	
37	731-0856		Hardtop Handle	N	98	750-0624		Shld. Spacer .50" Dia.	
38	764-0252		Grass Bag	N	100	711-0805		Shld Pin 3/8-24 x 1.43" Lg.	
39	710-0166		Truss Mach. Scr. 1/4-20 x 1.0" Lg.	N	101	736-0258		Fl-Wash. .375" I.D. x 1.0"	
40	12894		Hardtop Mounting Clip		104	736-0160		Fl-Wash. .531" I.D. x .93" (Optional)	
41	736-0463		Fl-Wash. .281" I.D. x .62" O.D.		105	17031		Rear Axle Ass'y.	N
42	712-0287		Hex Nut 1/4-20 Thd.*		107	710-0352		Hex L-Wash. HD AB-Tap Scr. 1/4 x .38" Lg.	
43	747-0693		Front Catcher Frame	N	108	736-0108		Fl-Wash. .510" I.D. x .75" O.D.	
44	749-0736		Rear Catcher Frame	N	109	711-0500		Spacer .526" I.D.	
45	731-0859		Chute Deflector	N	110	732-0481		Extension Spring 3.8" Lg.	
46	731-0970		Deflector Plug	N	111	711-0313		Sleeve .526" I.D.	
47	731-0858		Seal—Extrusion	N	113	714-0507		Cotter Pin 3/32" Dia. x .75"*	
48	720-0223		Grip		114	714-0104		Internal Cotter Pin 5/16" Dia.	
					115	15703		Cable Mtg. Brkt. (434R)	N

PARTS LIST FOR MODELS 434R THRU 439R ROTARY MOWERS (CONTINUED)

REF. NO.	PART NO.	COLOR CODE	DESCRIPTION	NEW PART
116	16704		Mounting Brkt. (434R)	N
117	710-0473		Truss Mach. Scr. #10 x .5" Lg. (434R)	
118	736-0722		L-Wash. #10 I.D. (434R)	
119	710-0776		Hex AB-Tap Scr. 1/4 x .62" Lg.	

*For faster service obtain standard nuts, bolts and washers locally. If these items cannot be obtained locally, order by part number and size as shown on parts list.

If color or finish is important when ordering parts, use the appropriate color code shown below [i.e. (part no.)—638 for MTD Red Finish].

NOTE: The engine is not under warranty by the mower manufacturer. If repairs or service is needed on the engine, please contact your nearest authorized engine service outlet. Check the "Yellow Pages" of your telephone book under "Engines—Gasoline."



Color Codes

312—White	480—Brilliant Green
436—Radiant Yellow	483—Charcoal Grey
447—Patina Silver	499—Beige
452—Black	629—Silver Flake
456—Radiant Tangerine	630—Blue
460—Green Flake	638—MTD Red

➔ NOTE

This instruction manual covers various models and all specifications shown do not necessarily apply to your model. Specifications subject to change without notice or obligation.

WHITE

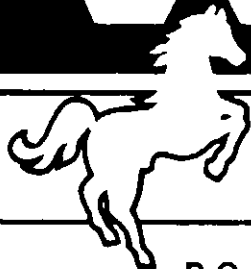

OUTDOOR POWER PRODUCTS

P.O. Box 8875 • Cleveland, Ohio • 44136
97 Kent Avenue • Kitchener, Ontario • N2G 4J1

Part No.	Description
777-7578	"WHITE" Deck Label
777-6810	"LAWN BOSS" Label—Engine
777-2196	Danger Label—Rear of Deck
731-0981	Radial Hub Caps