



OWNER'S MANUAL Trimmer/Mower

- Safety
- Assembly
- Features/Controls
- Operation
- Maintenance
- Parts List

Models

52057 – 5HP Recoil Start
52058 – 6HP Electric Start

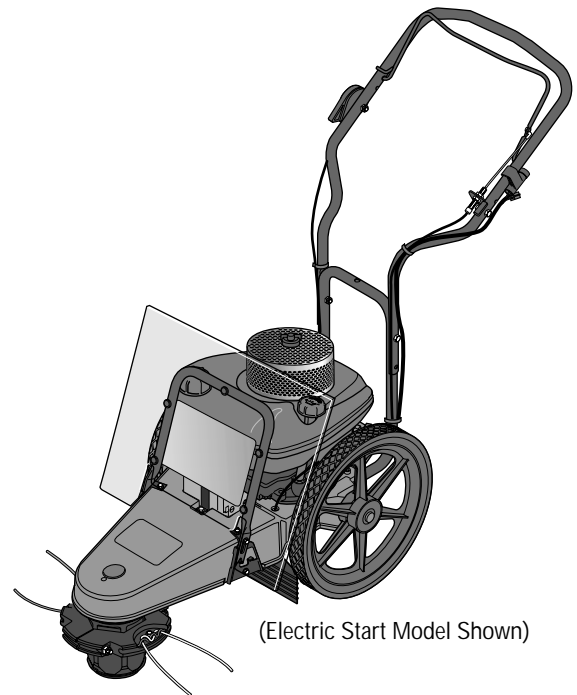

(Electric Start Model Shown)

Dear Owner:

You now own one of the finest trimmer/mowers available. It was designed to easily handle a wide variety of trimming, mowing and clearing chores. You will find the machine to be an invaluable tool in caring for your property.

Please carefully read this Manual which tells you how to safely and easily assemble, operate, and maintain your machine. *Be sure that you and any other operators carefully follow the recommended safety practices at all times. Failure to do so could result in personal injury or property damage.*

Of course, if you should ever have any problems or questions, please contact your local authorized service dealer or call the Factory.

We want to be sure that you are completely satisfied at all times.

Note: Be sure to fill out and return the Owner Registration Card that was supplied with this Manual.

**See Back Cover for
Customer Service Information**

Safety Alert Symbol



This is a safety alert symbol. It is used in this manual and on the unit to alert you to potential hazards. When you see this symbol, read and obey the message that follows it. Failure to obey safety messages could result in personal injury or property damage.



WARNING

The engine exhaust from this product contains chemicals known to the state of California to cause cancer, birth defects, or other reproductive harm.

Table of Contents

SECTION 1: SAFETY	1
General Operation	1
Slope Operation	2
Children.....	2
Service	2
Safety Decals	3
SECTION 2: ASSEMBLY	4
Inspection After Delivery	4
Step 1: Unpacking Unit	4
Step 2: Install Handlebars	4
Step 3: Attach Throttle Control Lever	5
Step 4: Add Motor Oil.....	5
Step 5: Check Trimmer Head Hardware	5
Step 6: Connect and Charge Battery.....	6
SECTION 3: FEATURES AND CONTROLS	7
SECTION 4: OPERATION	8
Pre-Start Checklist	8
Fill Fuel Tank	8
Adjust Handlebar Height	8
Adjust Line Cutting Height	8
Use the Correct Diameter Trimmer Line.....	9
Using the Trimmer Head Control Bail.....	9
Operating the Trimmer/Mower	9
Additional Operating Tips and Techniques	10
SECTION 5: MAINTENANCE	11
Required Maintenance Schedule	11
Adjusting Trimmer Head Engagement.....	11
Removing and Replacing the Trimmer Head.....	12
Inspecting/Replacing the Drive Belt.....	12
Cleaning and Debris Removal	14
Cleaning the Engine Debris Guard	14
Lubrication.....	14
Compact Storage	14
General Engine Maintenance	14
Engine Oil Service	14
Air Cleaner Service.....	14
Spark Plug Service.....	14
Spark Arrester Screen Service.....	14
Engine Cleaning	14
Carburetor/Governor Adjustments	14
Throttle Control Adjustment	15
Off-Season Storage	15
Battery Recharging/Replacement	15
Changing Trimming Lines	16
Troubleshooting.....	17
PARTS LIST	18
CUSTOMER SERVICE INFORMATION	Back Cover

Section
1

Safety

SPARK ARRESTER WARNING TO RESIDENTS OF CALIFORNIA AND SEVERAL OTHER STATES

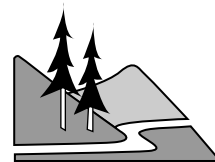

Under California law, and under the laws of several other states, you are not permitted to operate an internal combustion engine using hydrocarbon fuels on any forest covered, brush covered, or grass covered land, or on land covered with grain, hay, or other flammable agricultural crop, without an engine spark arrester in continuous effective working order.

The engine on your power equipment, like most outdoor power equipment, is an internal combustion engine that burns gasoline, a hydrocarbon fuel. Therefore, your power equipment must be equipped with a spark arrester muffler in continuous effective working order. The spark arrester must be attached to the engine exhaust system in such a manner that flames or heat from the system will not ignite flammable material. Failure of the owner/operator of the equipment to comply with this regulation is a misdemeanor under California law, and may also be a violation of other state and/or federal regulations, laws, ordinances, or codes. Contact your local fire marshal or forest service for specific information about what regulations apply in your area.

IMPORTANT

Safe Operation Practices for Walk-Behind Mowers

This cutting machine is capable of amputating hands and feet and throwing objects. Failure to observe the following safety instructions could result in serious injury or death.

General Operation

1. Read, understand, and follow all instructions on the machine and in the manuals. Be thoroughly familiar with the controls and the proper use of the equipment before starting.

2. Do not put hands or feet near or under rotating parts. Keep clear of the rotating trimmer head and line at all times.



3. Only allow responsible adults, who are familiar with the instructions, to operate the trimmer/mower. Never let children or untrained adults operate this equipment.

4. Inspect the area where the machine is to be used. The machine can propel small objects at high speed, causing personal injury or property damage. Clear the area of objects such as rocks, toys, wire, bones, sticks, etc., which could be picked up and thrown by the trimmer line.

5. Be sure the area is clear of other people (particularly small children and pets) before mowing. Stop machine if anyone enters the area. Keep bystanders at least 50 feet from the area of operation.



6. Do not operate the machine when barefoot or wearing open sandals. Always wear substantial footwear.

7. Wear appropriate clothing such as a long-sleeved shirt or jacket. Also wear long trousers or slacks. Do not wear shorts.

8. Do not wear loose clothing—it could catch in the equipment.

9. Do not mow in reverse unless absolutely necessary. Always look down and behind before and while moving backwards.

10. Do not operate the trimmer/mower without proper guards, plates, or other protective safety devices in place.

11. Refer to provided instructions for proper operation and installation of accessories. Only use factory-approved accessories.

12. Stop trimmer head when crossing gravel drives, walks, or roads. Wait for trimmer lines to stop.

13. Stop engine and disconnect spark plug wire from spark plug whenever you leave the unit, clean the equipment, or replace trimmer line.

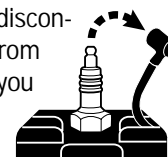

Remove key on electric start model.

14. Wait until the trimmer head comes to a complete stop, shut the engine off, and disconnect the spark plug wire before installing or removing trimmer line. Be sure trimmer head is securely attached before operating equipment.

15. Mow only during daylight hours or when good artificial light is available.

16. Do not operate the machine while under the influence of alcohol or drugs, or when tired or ill.

17. Never operate this equipment in wet grass. Be sure of your footing; keep a firm hold on the handlebar and walk; never run.

18. Release the Trimmer Head Control Bail before starting the engine.

19. If the unit starts to vibrate abnormally, stop the engine and disconnect the spark plug wire. Check immediately for the cause. Vibration is generally a warning of trouble.

Section 1: Safety

20. Always wear approved safety goggles or safety glasses with side shields when operating equipment. The use of any powered machine can result in foreign objects being thrown by high-speed rotating parts which can cause personal injury or property damage. Stay away from glass and other easily thrown or breakable objects.

21. Wear work gloves and sturdy footwear when using this equipment. Leather work shoes or short boots are ideal. They protect ankles and shins from rocks, pebbles, splinters, etc.

22. It is advisable to wear protective headgear to prevent the possibility of being hit by small flying particles, etc.

23. Before each use, inspect the Throttle Control Lever and cable. Make sure the cable is free and the lever functions properly.

24. Watch for traffic when near or when crossing roadways.

25. Never attempt to carry children or other passengers on the equipment. They could fall off and be seriously injured, or they could interfere with safe operation of the equipment.

26. The machine is equipped with a plastic debris shield in front of the engine and a rubber debris flap under the frame. They must be in place and working properly. Never remove or cause the debris shield or debris flap to cease working. If either of these parts is missing or not working properly, do not use the equipment until this situation is corrected.

27. Be aware of where the machine is discharging materials and do not point the discharge at anyone.

28. Never run the engine in an enclosed area. Engine exhaust contains carbon monoxide, a deadly gas that is odorless, colorless and tasteless. Always run the engine outdoors where there is adequate ventilation.

29. Slow down before turning.

30. Shut off engine when not trimming or mowing.

31. Use extra care when loading or unloading machine into a trailer or truck.

32. Use this equipment for its intended purpose only.

33. Always make sure the handlebars are tight and comfortably positioned.

They should never be in an awkward position for the operator.

Slope Operation

Slopes are a major factor related to loss of control and tip-over accidents which can result in severe injury or death. All slopes require extra caution. If you can not back up the slope or you feel uneasy on a slope, do not mow it.

DO:

Mow across the face of slopes; never up and down. Exercise extreme caution when changing direction on slopes. Avoid slopes greater than 15°.

Remove objects such as rocks, tree limbs, etc.

Uneven terrain could overturn the machine. Watch for holes, ruts, or bumps. Tall grass can hide obstacles.

Use slow speed.

Use extra care with grass catchers or other attachments. These can change the stability of the machine. Keep all movement on the slopes slow and gradual.

Avoid starting or stopping on a slope.



DO NOT:

Do not mow near drop-offs, ditches, or embankments. You could lose footing or balance.

Do not mow on very steep slopes.

Do not mow on wet grass. Slippery footing can be hazardous.

Children

Tragic accidents can occur if the operator is not alert to the presence of children. Children are often attracted to the machine and the mowing activity.

Never assume that children will remain where you last saw them.

1. Keep children out of the mowing area and under the watchful care of a responsible adult.
2. Be alert and turn machine off if children enter the area.
3. Before and while moving backwards, look behind and down for small children.
4. Never allow children to operate the machine.
5. Use extra care near blind corners, shrubs, trees, or other objects that may obscure vision.
6. Never carry children, even with the trimmer head stopped. Children may fall off and be seriously injured or interfere with safe machine operation.
7. Do not allow children nearby if you are working.

Service

1. Use extra care in handling gasoline and other fuels. They are flammable and their vapors are explosive. To help prevent a fire or explosion:
 - a) Use only an approved container.
 - b) Never remove gas cap or add fuel when the engine is running. Let engine cool before refueling. Do not smoke.
 - c) Never refuel the machine indoors. Fill the fuel tank outdoors and with extreme care.
 - d) Never store the machine or fuel container inside where there is an open flame, such as a water heater, etc.
 - e) Replace caps on the fuel tank and fuel container and clean up spilled fuel before starting engine. Move machine away from any gasoline fumes before starting the engine.
 - f) Keep matches, smoking materials, open flames, and sparks away from the fuel tank and fuel container.
 - g) Leave 1/2" air space at the top of the fuel tank to allow for fuel expansion.

2. Never run the engine inside a closed area.
3. Never clean, or make adjustments or repairs with the engine running. Disconnect the spark plug wire and keep the wire away from the plug to prevent accidental starting. Remove key on electric start models.
4. Keep all nuts and bolts tight, especially the trimmer head attachment bolts, and keep equipment in good condition. Check mounting hardware on trimmer head every time you change trimmer line and prior to each use.
5. Never tamper with safety devices. Check their proper operation regularly.
6. To reduce fire hazard, keep mower free of grass, leaves or other debris build-up. Clean up oil or fuel spills. Let machine cool before storing.
7. After striking an object, stop the engine and disconnect the spark plug wire. Inspect the machine and repair, if necessary, before restarting.
8. Never make adjustments or repairs while engine is running.
9. Components subject to wear, damage and deterioration could expose moving parts or allow objects to be thrown. Frequently check components and replace with factory recommended parts, when necessary. Regularly inspect the trimmer head

and debris shield. Make sure they are not bent, damaged, or loose.

10. Only use eighteen-inch long .130" or .155" diameter trimmer line. Never use other lengths, diameters or material as trimmer line.

11. Trimmer line moves at high speed and can cut. Always stop the engine and let all moving parts stop before replacing the trimmer lines. Let the engine cool.



12. Do not change the engine governor setting or overspeed the engine. The governor controls maximum safe operating speed and protects the engine and all moving parts from damage caused by overspeed. Authorized service shall be sought if a problem exists.

13. Do not touch engine parts which may be hot from operation. Allow parts to cool completely before inspecting, cleaning or repairing the unit.

14. Maintain or replace safety and instructional decals. Refer to the Parts List for replacement decal information.

15. Use only original-equipment replacement parts. Parts manufactured by others could present safety hazards and affect performance even though they may fit on this machine.

16. Remember – the end of the season is a good time to inspect equipment prior to storage.

17. To guard against engine overheating, always keep the engine debris guard mounted and clean.

18. For units equipped with electric start:

- a) Batteries produce explosive gases. Keep sparks, flame, cigarettes, etc., away. Ventilate area when charging battery. Do not charge battery in an airtight space.
- b) Do not use a battery charger other than the one provided with the unit.
- c) The battery contains toxic materials. Do not damage the battery case. If the case is broken or damaged, avoid contact with the battery contents.
- d) Properly dispose of a damaged or worn out battery. Check with local authorities for proper disposal methods.
- e) Do not short circuit the battery. Severe burns and fire can result.

Safety Decals

Make certain that all safety decals on this equipment are kept clean and in good condition. The decals are shown (at reduced sizes) below. If you need a replacement decal, refer to the Parts List in this Manual.



At front of deck



On left handlebar



On engine, above muffler

Assembly

⚠ WARNING

To prevent personal injury or property damage, do not attempt to start the engine until all assembly steps are complete and you have read and understand all of the safety and the operating instructions in this Manual.

Introduction

Carefully follow these assembly steps to correctly prepare your machine for use. It is recommended that you read this Section in its entirety before beginning assembly.

NOTE: If an assembly step applies only to certain models, those models are noted at the beginning of that step. Otherwise, a step applies to all models.

Inspection After Delivery

Inspect your machine immediately after it has been delivered. Make sure that neither the carton nor the contents have been damaged.

If you find or suspect any damage, contact the carrier (trucking company) right away. Inform them of the specific damage and that you wish to file a claim. To protect your rights, be sure to put this in writing to the carrier within 15 days after your machine arrives. Please let us know if you need assistance with this matter.

IMPORTANT: The engine is shipped without motor oil in its crankcase. Motor oil must be added to the engine before starting.

NOTE: LEFT and RIGHT sides of unit are as viewed from operator's position behind the handlebars.

Tools/Supplies Needed:

- (1) Utility Knife or Scissors
- (2) 1/2" (or adjustable) Wrenches
- (2) 7/16" Wrenches (one with a boxed end)
- Motor Oil (see Engine Owner's Manual for oil specifications and quantity required)

STEP 1: Unpacking Unit

1. Remove the protective packaging material (plastic film and cardboard) from the handlebars and the unit.
2. Remove the handlebars from the insert and carefully (do not pinch or kink the attached cables) put them aside before removing the unit from the shipping carton.
3. Compare the parts inside the carton with the following list:
 - Trimmer/Mower Assembly (A, Figure 2-1)
 - Extra Trimmer Line (B, Figure 2-1): six pieces of heavy-duty gauge .130" dia. line and six pieces of extra-heavy-duty gauge .155" dia. line.
 - The following items are in a separate package:
 - (1) Safety goggles
 - (3) Plastic cable ties
 - (1) Hex Hd. Screw, 1/4-20 x 2
 - (1) Hex Locknut, 1/4-20
 - (2) Hex Hd. Screw, 5/16-18 x 2
 - (2) Hex Locknut, 5/16-18
 - Electric Start Model Only:
 - (1) Battery (installed on unit – see C, Figure 2-1)
 - (2) Ignition Keys and (1) Battery Recharger (in separate electric start package)

STEP 2: Install Handlebars

1. Cut the plastic tie and remove the tape that secures the control bail (G, Figure 2-2) to the handlebar (A).
- NOTE: Do not pinch or kink the attached cable(s) while unfolding and securing the handlebars.
2. Carefully lift the handlebars (A, Figure 2-2) to rear of the unit and align the handlebar legs with the handlebar support bracket (B).
 3. Route the trimmer head control cable (C, Figure 2-2) to the outside of the handlebar. On electric start models, also route the electrical wire harness (O) to the outside of the handlebar.
 4. Select the low or high height setting holes in the handlebar legs and attach the legs with the two 5/16-18 x 2 hex hd. screws (D) and 5/16-18 locknuts (E) from the hardware bag.
- IMPORTANT:** Adjust the handlebars as close as possible to waist level so that your arms are at a comfortable height. This position will result in less pressure on the mower wear cup, making the unit easier to roll and reducing wear to the wear cup.

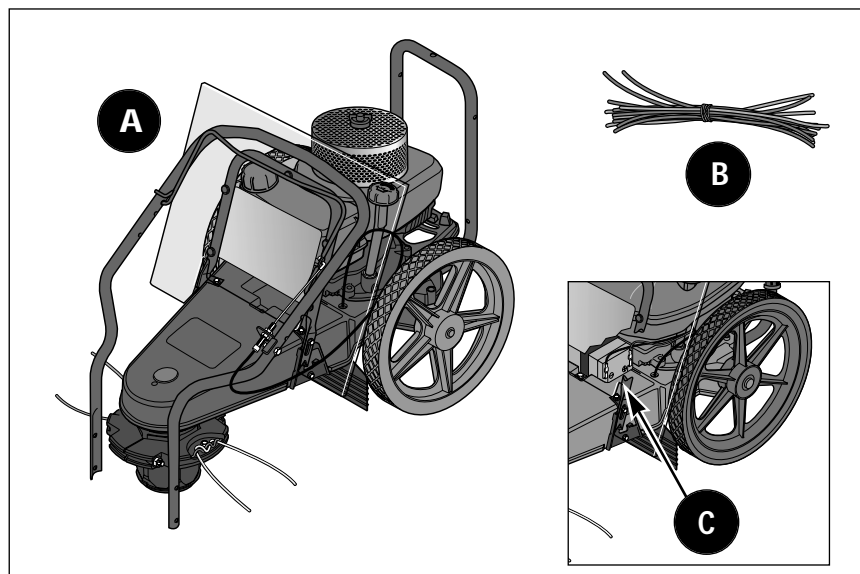

Figure 2-1: Unit as shipped (recoil start model shown). Battery for electric start model is shown in inset.

5. Use two cable ties (F, Figure 2-2) to secure the trimmer head control cable (C) and the electrical wiring harness (O) to the handlebar at the locations shown.

STEP 3: Attach Throttle Control Lever

1. One end of the Throttle Control Cable (H, Figure 2-3) is attached to the engine. Gently unwind the cable from its shipping position and position the Throttle Control Lever (I) on the outside of the right handlebar, next to the throttle control decal.
2. Secure the Throttle Control Lever to the handlebar with a 1/4-20 x 2 hex hd. screw (J, Figure 2-3) and 1/4-20 hex locknut (K).
3. Use a cable tie (L, Figure 2-3) to secure the throttle cable (H) to the handlebar at the location shown.

STEP 4: Add Motor Oil

1. The engine is shipped without motor oil which **MUST BE ADDED** before the engine is started.
2. See the separate Engine Owner's Manual for filling instructions and for the correct oil specifications. Engine must be level when checking oil level. In ambient temperatures above 32°F, use a high-quality, SAE 30 weight detergent oil classified for Service SF-SJ. Use no special additives. Do not mix oil with fuel.

STEP 5: Check Trimmer Head Hardware

Check that the two bolts (M, Figure 2-4) on the trimmer head are tightened securely. The trimmer head can be rotated to make access to the hardware easier.

IMPORTANT: The trimmer head hardware is designed to be permanently installed and is not removable. Do not attempt to replace it with non-factory specified hardware.

NOTE: The two holes (one is covered with a plastic plug) on the top, front end of the mower deck are access holes that allow certain parts to be serviced.

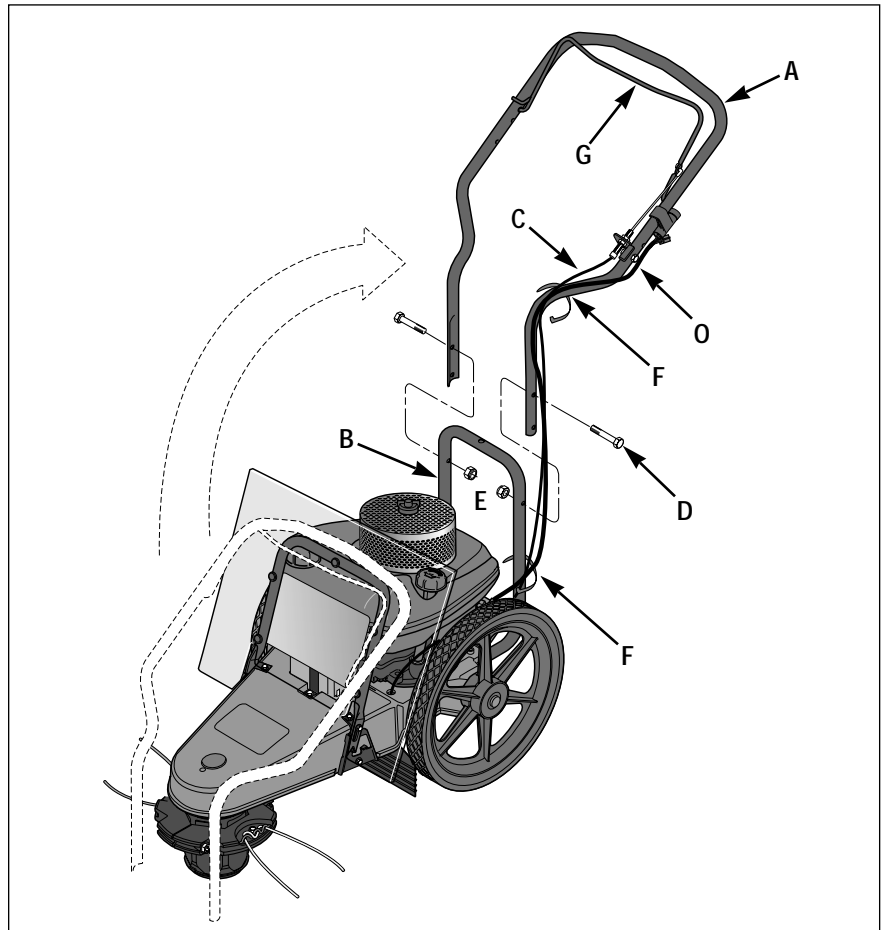

Figure 2-2: Handlebar installation (electric start model shown).

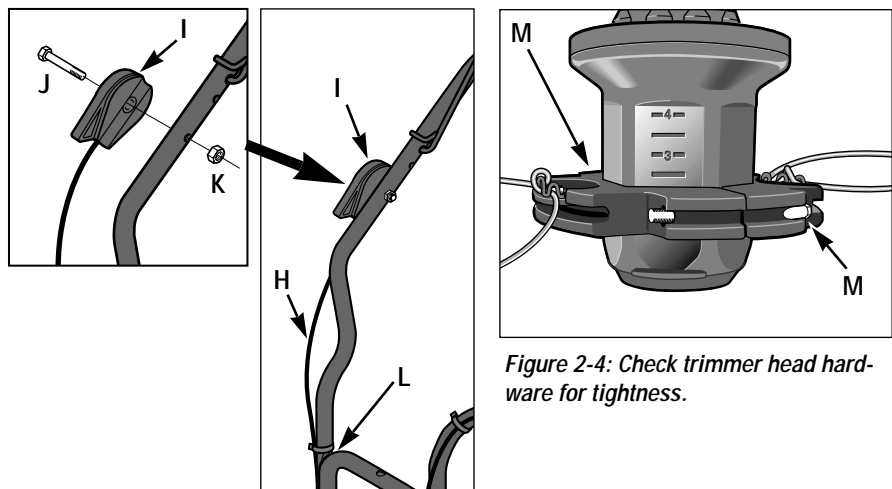

Figure 2-3: Attach throttle lever to right-side handlebar.

Figure 2-4: Check trimmer head hardware for tightness.

Section 2: Assembly

STEP 6: Connect and Charge Battery (Electric Start Models)

⚠ DANGER

- Wet conditions can cause an electric shock hazard during battery recharging. Avoid wet conditions when charging battery.
- Recharging the battery with improper equipment could cause a battery explosion. Use only the battery charger shipped with the unit. The engine must be shut off and the spark plug wire disconnected and moved away from the spark plug.

Failure to comply could result in personal injury or property damage.

1. Lift and tilt debris shield (X, Figure 2-5) forward to view battery (P). Connect the red wire (R, Figure 2-6) to the positive (+) red-coded terminal on the battery. Then, connect the black wire (S) to the negative (-) black-coded terminal on the battery. Close the debris shield (X, Figure 2-5).
2. Connect the small plug (U, Figure 2-7) on the battery recharger cord to the wire harness plug (V) located near the keyswitch. Then, plug the charger box (W) into a grounded, 120V wall outlet.
3. Charge the battery for 24 hours. After charging, first unplug the charger box (W) from the wall outlet, then disconnect the recharging line plugs (U and V).

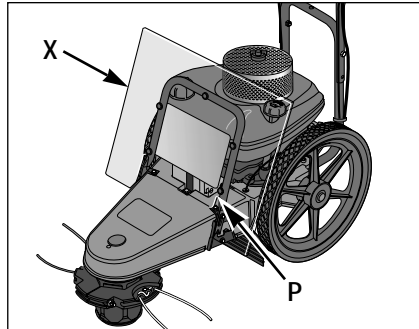

Figure 2-5: Lift and tilt debris shield forward to access battery.

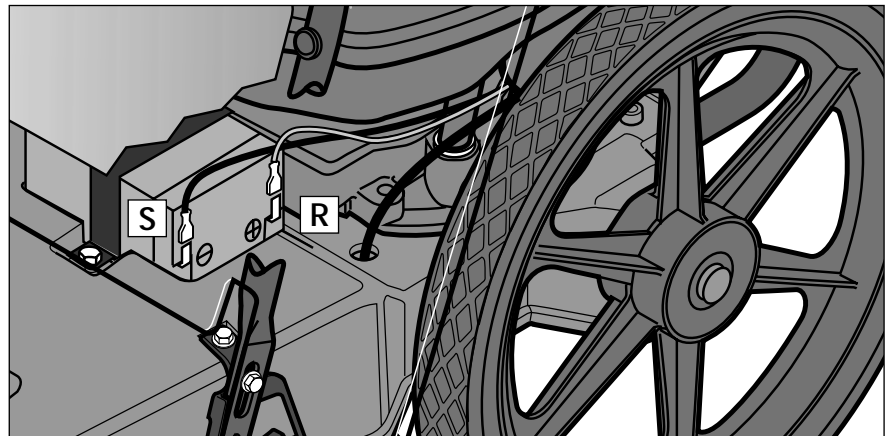

Figure 2-6

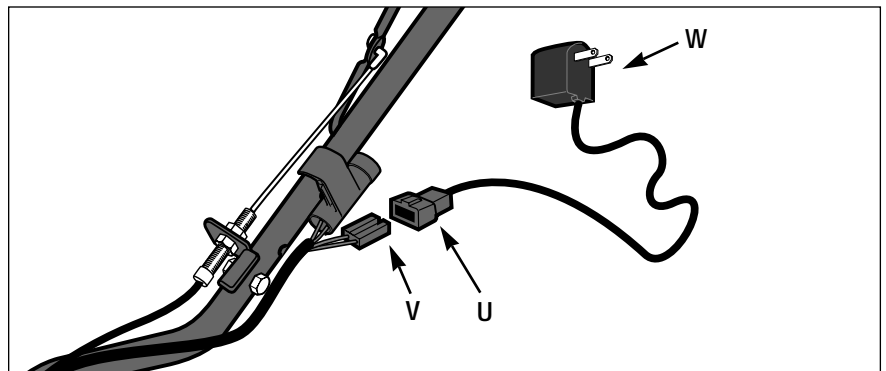

Figure 2-7

Features and Controls

Operating Symbols

Various symbols (shown here, with word descriptions) are used on the unit.



ENGINE STOP



FAST



SLOW



STOP



TRIMMER HEAD



ENGAGE BAIL



DISENGAGE BAIL

FEATURES AND CONTROLS

This Section describes the location and function of the features and controls on your machine. Refer to the following *Operation* Section for detailed operating instructions.

Do not start the engine until you read and understand all safety, controls and operating instructions in this Manual, the separate Engine Owner's Manual, and on the decals on the machine.

IMPORTANT: Refer to the separate Engine Owner's Manual for detailed information about the controls on the engine.

Trimmer Head Control Bail

Pull the control bail (A, Figure 3-1) up against the handlebar (engage bail) to start rotation of the trimmer head. Let go of the control bail (disengage bail) to stop the trimmer head.

Cutting Height Settings

The trimmer head (B, Figure 3-1) is adjustable to an infinite number of height settings from 1-1/2" -to- 4-1/2".

Trimmer Line Holders

The trimmer lines are secured to line holders (C, Figure 3-1). Replacing the trimmer lines is a simple procedure (see *Changing Trimming Lines* in Section 5).

Handlebar Height Adjustment

The handlebar (D, Figure 3-1) has two height settings (see *Adjust Handlebar Height* in the *Operation* Section).

Plastic Debris Shield

The plastic debris shield (E, Figure 3-1) protects the engine from all manner of debris. The shield tilts forward for access to the engine.

Engine Throttle Control Lever

Use this lever (F, Figure 3-1) to regulate engine speed and to stop the engine. The throttle settings are shown on the decal next to the lever.

Engine Recoil Starter

The recoil starter (G, Figure 3-1) is located at the rear of the engine and is used to pull start the engine.

Engine Debris Guard

The engine debris guard (H, Figure 3-1) protects the engine from accumulations of cut materials that can clog the engine cooling passages. See the *Maintenance* Section for information on servicing this important guard.

Fuel Primer Button

The fuel primer button (I, Figure 3-2) allows a cold engine to be primed for faster, easier starting.

Keyswitch (Electric Start Model)

On electric start models, the keyswitch (J, Figure 3-1) is used to start the engine. The keyswitch does not have an engine stop position. Use the Engine Throttle Control Lever (F) to stop the engine.

IMPORTANT: Remove key from keyswitch when leaving unit unattended to help prevent unauthorized or unintentional starting.

Battery (Electric Start Model)

On electric start models, the battery (K, Figure 3-1) will crank the engine starter motor when the keyswitch is turned to the start position. Do not crank engine longer than five (5) seconds per each starting attempt.

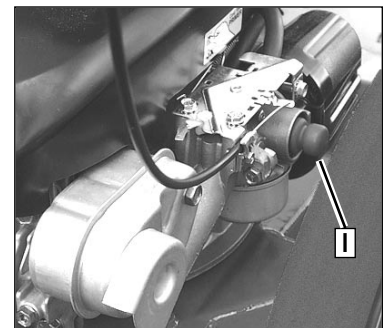
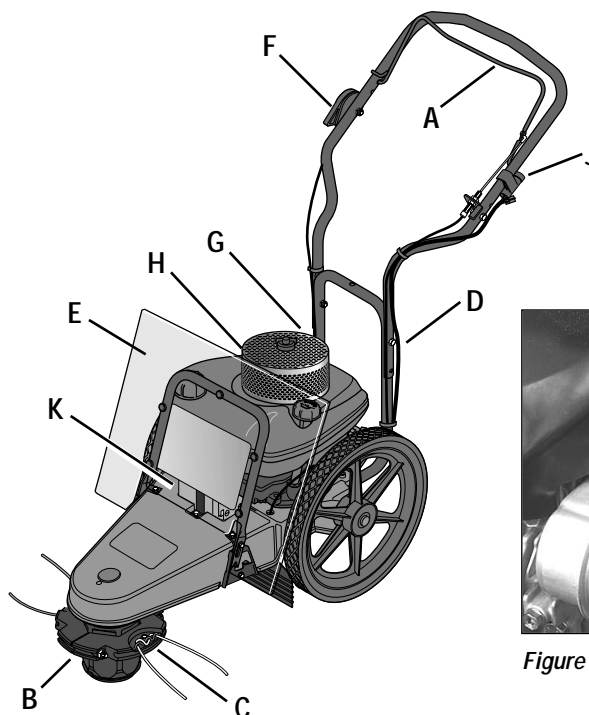

Figure 3-2: Engine primer.

Figure 3-1: Features and controls (electric start model shown).

⚠ WARNING

Before operating your machine, carefully read and understand all safety (Section 1), controls (Section 3) and operating instructions (Section 4) in this Manual, in the separate Engine Owner's Manual, and on the decals on the machine.

Failure to follow these instructions can result in serious personal injury.

INTRODUCTION

Read this Section thoroughly before you start the engine. As with any piece of outdoor power equipment, getting the "feel" for how your machine operates and knowing the best techniques for particular jobs are important to overall good performance.

NOTE: All references to LEFT, RIGHT, FRONT and REAR of the machine are determined by standing in the operator's position.

PRE-START CHECKLIST

1. Review Section 1: *Safety* and also Section 3: *Features and Controls*.
2. Check for loose or missing hardware. Tighten or replace as needed.
3. Check the engine oil level*. It must be up to the "FULL" mark on the oil dipstick. (See the Engine Owner's Manual for instructions.)
4. Check the fuel level* in the fuel tank. (See the Engine Owner's Manual and this page for instructions.)
5. Check the Trimmer Head Control Bail and the Engine Throttle Control Lever for freedom of movement.
6. Select the cutting height (see *Adjust Line Cutting Height* in this Section).
7. Check handlebar height position.
8. On electric start models, check the wire harness connections.
9. Carefully check the area to be trimmed and remove any debris.
10. Install the correct diameter trimmer line (see *Use the Correct Diameter Trimmer Line* in this Section).

11. Check that the spark plug wire is securely attached to the spark plug.

* Clean debris from around fuel cap, oil dipstick, and engine debris guard before checking oil level or adding gasoline, in order to keep dirt out of engine.

FILL FUEL TANK

⚠ DANGER

GASOLINE IS HIGHLY FLAMMABLE AND ITS VAPORS ARE EXPLOSIVE.

Follow gasoline safety rules in this Manual (see Section 1) and in the separate Engine Owner's Manual.

Failure to follow gasoline safety rules and instructions can result in serious personal injury and property damage.

1. Lift and tilt plastic debris shield (E, Figure 3-1) forward.
2. Clean fuel fill area and engine debris guard each time before fuel is added.
3. Fill the fuel tank with gasoline according to the directions in the separate Engine Owner's Manual. Follow all instructions and safety rules carefully.
4. Securely replace the fuel tank cap and the fuel container cap. Promptly wipe up any fuel spills.
5. Lift and tilt the debris shield back, then push it down to secure it.

ADJUST HANDLEBAR HEIGHT

⚠ CAUTION

Before adjusting handlebar height, stop engine and wait for all moving parts to stop, disconnect spark plug wire and prevent it from touching spark plug.

Failure to comply could result in personal injury or property damage.

To adjust handlebar height, refer to *Install Handlebars* in the *Assembly* Section of this Manual.

ADJUST LINE CUTTING HEIGHT

⚠ CAUTION

Before adjusting the cutting height, shut off the engine, wait for all moving parts to stop, allow the engine to cool, disconnect the spark plug wire and prevent it from touching the spark plug.

Failure to comply could result in personal injury or property damage.

The cutting height of the trimmer line adjusts from 1-1/2"-to-4-1/2" high in infinite increments. The cutting height has been factory-set at one of the higher settings – we recommend that you start at this higher setting and make adjustments as needed.

In general, use higher height settings to handle taller material and to cope with tougher cutting conditions. For less demanding situations, use any trimming height desired. To adjust the cutting height:

1. The cutting line height can be changed when the wear cup is in contact with the ground. If necessary, you may tip the unit back slightly for a better view (do not tip unit all the way back or motor oil may flow to the exhaust area and the engine may smoke for several seconds when started).
2. Use a 1/2" wrench to loosen both bolts (A, Figure 4-1) securing the trimmer head.
3. The cutting heights are marked on the side of the spindle head (Figure 4-2). Move the top of the trimmer head to the desired setting.
4. Tighten both trimmer head bolts securely (to 75 in/lbs.) and evenly.

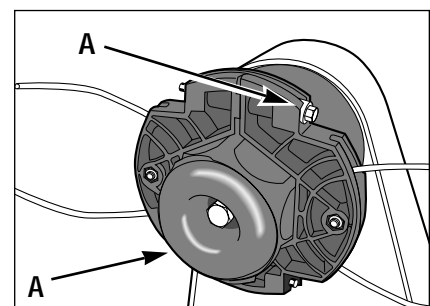

Figure 4-1

USE THE CORRECT DIAMETER TRIMMER LINE

Before starting a project, examine the grass or material you will be cutting and trimming.

For tougher conditions, use two (or four) sections of the thicker gauge, .155" diameter extra-heavy duty line. For less demanding conditions, use two sections of the thinner gauge, .130" diameter heavy-duty line. The thicker line has the heft to chop through tougher materials, while the thinner line provides a more precise cut. To change trimmer lines, refer to *Changing Trimmer Lines* in Section 5.

NOTE: The thinner gauge line is also recommended for use near trees or ornamentals to help prevent girdling (cutting the bark).

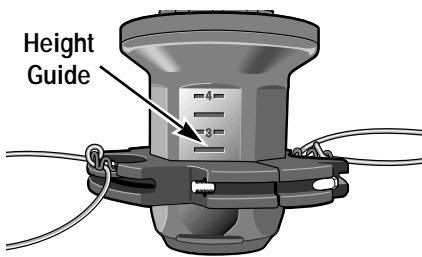

Figure 4-2

USING THE TRIMMER HEAD CONTROL BAIL

Before starting the engine, it is essential to know how to use the Trimmer Head Control Bail.

1. The Trimmer Head Control Bail (A, Figure 4-3) is used to start and stop trimmer head motion.
2. Leave the control bail in the disengaged (released) position when starting the engine to prevent the trimmer head from turning when the engine starts. See Figure 4-3.
3. When the engine is running, pull up and hold the control bail against the handlebar (Figure 4-4) to start rotation of the trimmer head.
4. Let go of the control bail to stop the trimmer head. The control bail should spring forward to the disengaged position. If it doesn't, do not use the machine until the control bail has been repaired.

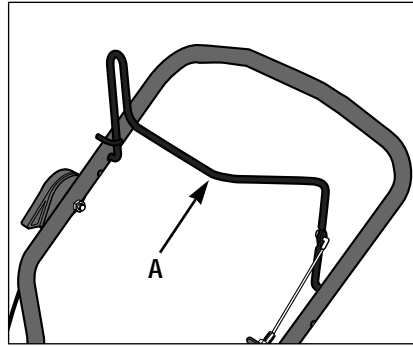

Figure 4-3: Control bail disengaged.

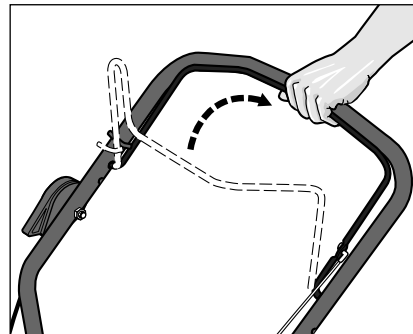

Figure 4-4: Control bail engaged.

⚠ WARNING

If the trimmer head control bail is not operating properly, shut off the engine, disconnect the spark plug wire and move wire away from plug.

Adjust or repair the control bail before using the trimmer/mower.

Failure to follow this instruction could result in personal injury or property damage.

OPERATING THE TRIMMER/MOWER

Once you have read and understood the sections in this Manual on *Safety, Assembly, Features and Controls*, and *Operation*, you are ready to start and operate your trimmer/mower.

Checklist Before Starting

1. Complete the *Pre-Start Checklist* in this Section of the Manual. You must wear safety glasses or goggles.
2. Check that the line cutting height is adjusted according to the instructions.

Starting the Engine

1. Move the unit to the work area.
2. Connect the spark plug wire to the spark plug.
3. Put on safety-approved eye protection.
4. Release (disengage) the Trimmer Head Control Bail (A, Figure 4-3).
5. Put the Engine Throttle Control Lever in the FAST (rabbit symbol) position.
6. Push in the fuel primer button as instructed in the Engine Owner's Manual. NOTE: Do not use primer to restart a warm engine after a short shutdown.
7. Recoil Starting: Pull recoil start rope slowly until resistance is felt. Then pull rope out rapidly to start engine. Let rope back in slowly. NOTE: If engine fails to start after three pulls, repeat step 6.

Electric Starting: Stand behind handlebars and turn ignition key clockwise to crank engine. If engine does not start after five seconds of cranking, stop and repeat step 6. When engine starts, release key.

To Start the Trimmer Head

1. Stand in the operator's position directly behind the handlebars.
2. Slowly close the Trimmer Head Control Bail (Figure 4-4) against the handlebars to activate the trimmer head. Use the Engine Throttle Lever to adjust the turning speed of the trimmer head.
3. Once the trimmer head is revolving, push the trimmer/mower along the path to be cut.

To Stop the Trimmer Head

Let go of the Trimmer Head Control Bail. It will return to its open position and the trimmer head will stop turning.

To Stop the Engine

Put the Engine Throttle Control Lever in the STOP position. (If time allows, first move throttle lever to SLOW setting before stopping engine.)

Section 4: Operation

WARNING

THROWN OBJECT HAZARD

- Objects such as rocks, pebbles, and small debris will be thrown violently by the cutting head, resulting in significant hazard to eyes and exposed body parts.
- Always wear safety-approved eye protection and suitable clothing and footwear.
- Keep children, pets and bystanders 50 feet away from machine while operating.
- Be alert to hidden obstacles.

Failure to comply could result in injury or property damage.

ADDITIONAL OPERATING TIPS AND TECHNIQUES

Tips for Precision Cutting

For the most precise cutting possible, be sure to select the appropriate line cutting height and trimmer line size (thickness) for the conditions at hand.

When mowing, let the cutting head rest lightly on the ground and do not lift up on the handlebars. This allows the cutting head to follow the ground contour closely, resulting in the most even cut possible. Also, be sure to ease into heavy growth to prevent overwhelming the machine.

Trim When Wet or Dry

Grass and most other materials are most efficiently trimmed when dry. But, the trimmer/mower will do a fine job even with damp or wet materials. When conditions are moist or damp, be sure to clean debris off the machine regularly to keep cutting efficiency high. And watch your footing!

Clean the Trimmer/Mower On a Regular Basis

Clean under the mower deck frequently to remove any grass buildup. Also clean around the muffler and on top of engine. See the cleaning instructions in Section 5: *Maintenance*.

Do Not Let the Trimmer Lines Become Too Short

Once the trimmer lines are worn to less than 1/2 their original length, trimming jobs begin to take far longer than they should.

As a general guideline, once the line length becomes half of its original length, it's time to change to new lines.

Use Extreme Caution on Slopes

When operating on sloping ground, use extreme caution and common sense to avoid possible injury or property damage.

Do not mow on excessively steep slopes! Avoid slopes if greater than 15° or wherever footing is unsure. If a slope is difficult to stand on, it is probably too steep to trim or mow. In this case, it may be wiser to establish a permanent ground cover on this area.

Do not trim on slopes when the ground is slippery. Trim across the face of a slope, not up and down. Slow down and exercise caution when changing direction on slopes.

Use Correct Walking Speed

Use a walking speed that is suitable for the conditions at hand. For example, you'll get better trimming and mowing results at slower walking speeds if the grass is tall or lush. Shorter grass or less dense growth can be cut at faster travel speeds.

Vary the Throttle Setting According to Conditions

The majority of trimming and mowing jobs will yield the best results if the Engine Throttle Control is set at the fastest engine speed.

Less demanding jobs that require very precise cutting will yield better results if the engine throttle is backed off somewhat to reduce engine speed. (For example, damage to trees and ornamentals can be avoided by reducing the engine speed; using the lighter .130" diameter line; and by keeping a safe distance away.)

Again, once you begin a particular job and get a "feel" for the conditions, you will be able to make adjustments for the best possible results.

Keep the Mowed Side to Your Right as You Move Ahead

The trimmer/mower feeds cut materials to the right side. Stay on the right side of unmowed growth as you move along.

NOTE: If the trimmer is operated in a stationary position with the wear cup in contact with dry vegetation, significant heat will result that may deform the plastic spindle or scorch vegetation.

Maintenance

⚠ WARNING

Before inspecting, cleaning or servicing the machine, shut off engine, disconnect spark plug wire, and make sure that all moving parts have come to a complete stop. Remove ignition key on electric start models.

Failure to follow these instructions can result in personal injury or property damage.

NOTE: LEFT and RIGHT sides of unit are as viewed from operator's position behind the handlebars.

REQUIRED MAINTENANCE SCHEDULE

REQUIRED MAINTENANCE	BEFORE EACH USE	EVERY 5 HOURS	EVERY 25 HOURS	EVERY 100 HOURS	AS NOTED
CHECK ENGINE OIL LEVEL	•	•			
CHECK TRIMMER/MOWER LINES	•				1
CHECK TRIMMER HEAD ENGAGEMENT	•				
ENGINE/MACHINE CLEANING	•				3
CHECK NUTS AND BOLTS	•				
CHANGE ENGINE OIL			•		2, 5
SERVICE AIR FILTER SYSTEM			•		5
CLEAN UNDER DECK			•		
GENERAL LUBRICATION			•		
INSPECT DRIVE BELT				•	
CLEAN ENGINE DEBRIS GUARD	•				4
CHECK WEAR CUP		•			6

Chart 5-1

NOTE 1 – New line replacement is suggested when old line is 50% or less of original length.

NOTE 2 – Change oil after first two hours of new operation; thereafter every 25 hours.

NOTE 3 – Clean daily if used in extremely dusty/dirty conditions (see Engine Owner's Manual).

NOTE 4 – Clean before using machine and at each fuel refill.

NOTE 5 – Service more often if used in extremely dusty or dirty conditions (see Engine Owner's Manual).

NOTE 6 – Replace when severe gouges exist on bottom surface.

ADJUSTING TRIMMER HEAD ENGAGEMENT

The tension on the drive belt must be correct for proper operation of the trimmer head. If the tension is correct, the trimmer head will rotate when the Trimmer Head Control Bail is pulled back against the handlebar (another indication of correct tension is if the engine stalls when the trimmer head becomes bound up in very tough material.)

A worn or loose drive belt will slip on its pulleys, causing the trimmer head to move slowly, or not at all, when the control bail is engaged (belt squealing may also be noticeable).

If the tension is too tight, the trimmer head may rotate before the control bail is engaged, or when there is no free play in the control bail.

To Adjust Belt Tension

1. Stop the engine and wait for all parts to stop moving. Adjust the position of the two nuts on the control cable adjustment stud (see Figure 5-2) as described next:

- To tighten belt tension, move the upper nut (A, Figure 5-2) upward, then move the lower nut (B) upward. Tighten both nuts securely.
- To loosen belt tension, move the lower nut (B, Figure 5-2) down and then the upper nut (A) down. Tighten both nuts securely.

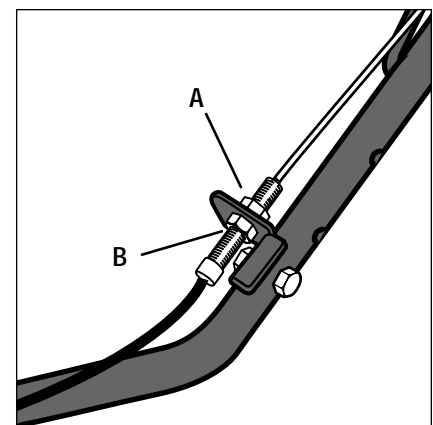
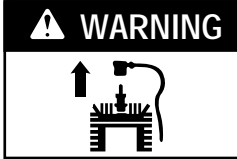

Figure 5-2: Belt tension adjustment.

Section 5: Maintenance



WARNING Before inspecting, cleaning or servicing the machine, shut off engine, wait for all moving parts to come to a complete stop, disconnect spark plug wire and move wire away from spark plug. Remove ignition key on electric start models. Failure to follow these instructions can result in serious personal injury or property damage.

REMOVING AND REPLACING THE TRIMMER HEAD

1. Stop the engine and wait for all moving parts to stop. Disconnect spark plug wire and move it away from the spark plug. Remove the ignition key on electric start models.
2. Two bolts (A, Figure 5-3) secure the trimmer head (B) to the spindle head (C). Loosen both bolts (not the nuts) just enough to open up the trimmer head and allow it to slide down the spindle head and past the two stops. Do not attempt to remove the bolts completely – they are permanently attached.
3. Install the new trimmer head on the spindle head. Tighten the hardware securely (to 75 in/lbs.) and evenly.
4. If the wear cup (D, Figure 5-3) is worn, replace it. Use a 1/2" socket wrench to remove the screw (E, Figure 5-3) and washer (F). Install the new wear cup and reinstall the washer and screw. Tighten the screw securely.

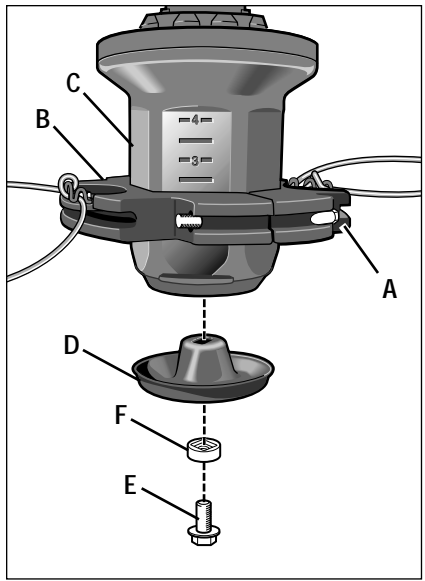

Figure 5-3

INSPECTING / REPLACING THE DRIVE BELT

The drive belt can be inspected or replaced from beneath the machine deck. The belt should not require inspection for many hours of operation. If replacement becomes necessary, follow the instructions given here.

Belt Inspection

Stop the engine and let all moving parts stop. Allow the engine to cool. Disconnect the spark plug wire and move it away from the spark plug. Remove the ignition key on electric start models.

1. For convenience, we recommend that you place the unit on a raised platform to make access to the underside of the deck as easy as possible.
2. Examine the belt. Feed it around the rear (engine) pulley so the entire belt can be examined. If cracks or other damage are noted, a new belt is needed.

Belt Removal

1. Stop the engine and wait for engine to cool. Disconnect the spark plug wire and move it away from the spark plug. Remove the ignition key on electric start models.
2. Remove gasoline from fuel tank.

! DANGER

GASOLINE IS HIGHLY FLAMMABLE AND ITS VAPORS ARE EXPLOSIVE.

- Drain fuel into approved container outdoors, away from open flame.
- Be sure engine and muffler are cool before draining gasoline.
- Do not smoke.

Failure to comply can result in serious personal injury and property damage.

3. Carefully tip unit on its left side and secure it in place.
4. Remove the plastic plug (A, Figure 5-4) from the top of the mower deck.
5. Using a 3/4" socket wrench, remove nut (B, Figure 5-4), Belleville washer (C) and flat washer (D) from spindle shaft (E).

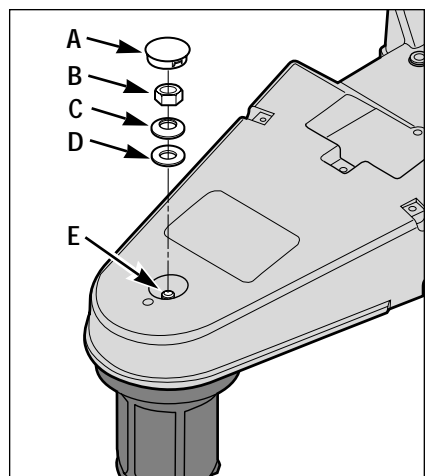
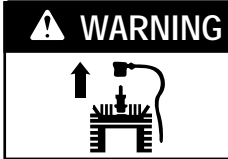

Figure 5-4

6. Thread nut (B, Figure 5-4) a few turns back onto spindle shaft (E) to protect threads on spindle shaft during the next step.
7. Loosen the spindle shaft by placing a wood block against the top of the nut (B, Figure 5-4) and firmly striking the wood block with a hammer.
8. Remove the nut from the spindle shaft and then remove the spindle shaft (E, Figure 5-5) and entire spindle head assembly (F) from the bottom of the deck. Slip the belt off the spindle head pulley (P).
9. Disconnect the idler arm spring (R, Figure 5-6) from the hole in the idler arm (T).
10. Using a 1/2" wrench, loosen the idler arm mounting screw (S, Figure 5-6) two full turns.



WARNING

Before inspecting, cleaning or servicing the machine, shut off engine, wait for all moving parts to come to a complete stop, disconnect spark plug wire and move wire away from spark plug. Remove ignition key on electric start models. Failure to follow these instructions can result in serious personal injury or property damage.

11. Using a 9/16" wrench and a 7/32" hex (Allen) wrench, loosen the mounting nut (G, Figure 5-6) and screw on the idler pulley (I) a few turns, or until belt is free to slip out between pulley and belt guide (J). Remove belt.

12. Loosen rear belt guide screw (K, Figure 5-6) enough to allow belt to be removed from engine pulley (L). Remove belt from unit.

Belt Replacement

1. Install belt on engine pulley (L, Figure 5-6) and retighten rear belt guide screw (K) securely.

2. Route belt between idler pulley (I, Figure 5-6) and belt guide (J), to inside of brake arm (M), and next to die-cast belt guides (N).

3. Securely tighten the mounting nut (G, Figure 5-6) and screw in the idler pulley (I).

4. Securely tighten the idler arm mounting screw (S, Figure 5-6). After tightening, check that idler arm is free to rotate. If not, remove idler arm and check for debris that may be interfering with freedom of movement.

5. Look at the spindle head mounting hole (O, Figure 5-6) and note the grooves that are cut into the inner sides of the hole. These grooves were formed by the splines on the spindle shaft (E, Figure 5-5).

6. Install the belt on the spindle head pulley (P, Figure 5-5) and insert the spindle shaft (E) (with attached spindle head assembly) into the spindle head mounting hole (O, Figure 5-6). Rotate the spindle head assembly to align the splines on the spindle shaft with the grooves in the mounting hole. Check that the belt is still in the pulley groove and is to the inside of the die-cast belt guides (N, Figure 5-6).

7. Using a firm push on the spindle

head assembly (Figure 5-6A), seat the spindle head assembly into the hole. Check that the threaded end of the spindle shaft is protruding through the bottom of the hole.

8. Reinstall the flat washer (D, Figure 5-4), belleville washer (C) and nut (B) on the spindle shaft. Note that the dished-in side of the belleville washer must face the flat washer. Tighten the nut securely (torque to 50 ft./lbs.), while checking frequently to ensure that the spindle head rotates freely. If the spindle head binds, it could be due to the belt being pinched between the spindle head and the belt guides. If so, remove the spindle head assembly and repeat steps 5-7.

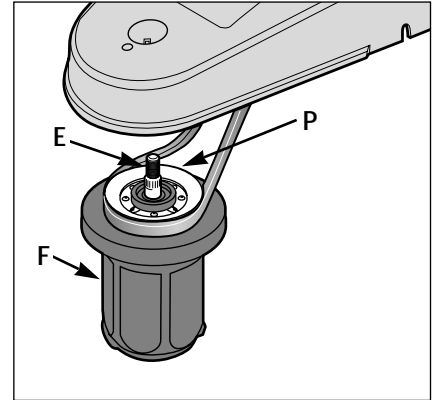

Figure 5-5

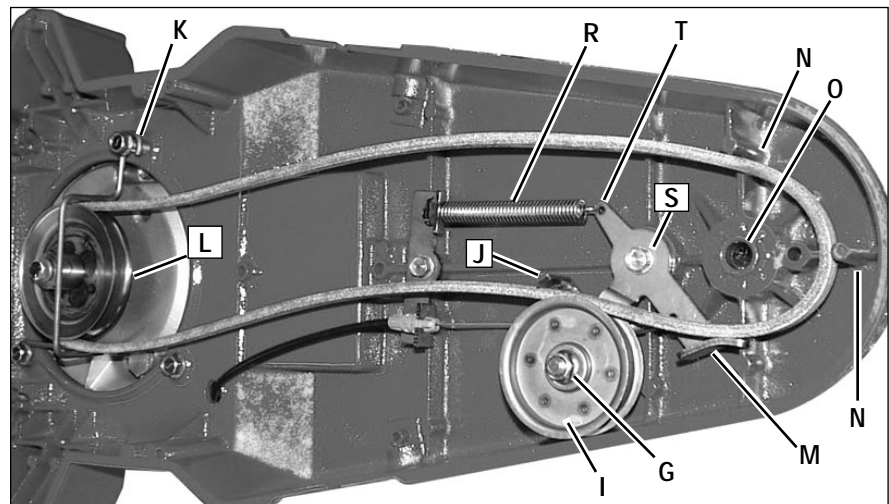

Figure 5-6

9. Replace plastic plug (A, Figure 5-4).

10. Reattach the idler arm spring (R, Figure 5-6) in the hole in the idler arm (T).

11. A new belt may need to be adjusted by following the *Adjusting Trimmer Head Engagement* instructions in this Section.

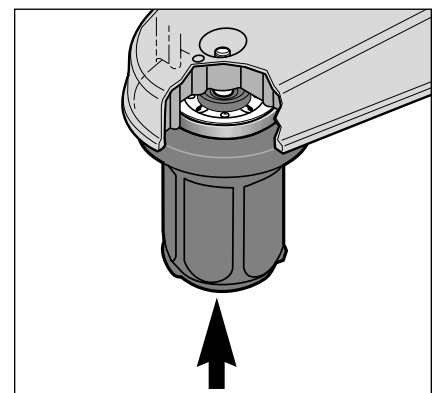

Figure 5-6A

Section 5: Maintenance

WARNING



Before inspecting, cleaning or servicing the machine, shut off engine, wait for all moving parts to come to a complete stop, disconnect spark plug wire and move wire away from spark plug. Remove ignition key on electric start models.

Failure to follow these instructions can result in serious personal injury or property damage.

TRIMMER/MOWER CLEANING AND DEBRIS REMOVAL

Thorough and regular cleaning of debris from around the engine and on the machine is required for maximum engine efficiency and good overall performance. Inspect and clean the following areas regularly, making sure the engine is stopped, and cool, before proceeding:

- Brush and wipe off all engine surfaces, especially before checking oil or adding fuel. Do not let oil or grease accumulate. For access to the front of the engine, the debris shield can be lifted up and tilted forward.
- Wipe the deck clean, particularly near the engine muffler.
- Clean the underside of the deck.
- Keep safety and operating decals clean and legible.
- Keep all operating control levers debris-free so they work properly.

CLEANING THE ENGINE DEBRIS GUARD

It is extremely important to keep the engine debris guard (A, Figure 5-7) free of dirt and debris so the engine can run as efficiently and as cool as possible.

Brush the debris guard clean before using the unit each time and whenever you see a build-up of dirt and debris.

NOTE: The separate engine air cleaner must also be serviced according to the instructions in the Engine Owner's Manual.

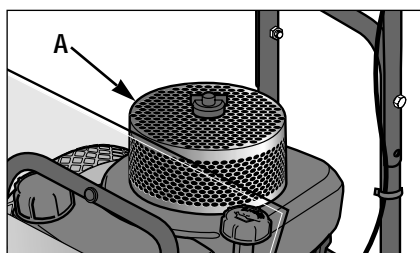

Figure 5-7

WARNING

Never run engine without debris guard properly installed. If debris guard is not properly installed, grass clippings may be drawn into engine, causing heat buildup and, in some cases, a fire.

Failure to comply can cause injury or property damage.

LUBRICATION

Applying light oil or a silicone-based lubricant to your machine allows parts to work more smoothly and protects them from the elements. The following are general guidelines:

Silicone-base Spray Lubricant (or light oil):

- Throttle control cable
- Control bail cable
- Nuts, bolts and other hardware

NOTE: The spindle head is permanently lubricated at the factory. There is no need for additional lubrication.

COMPACT STORAGE

For compact storage of the unit, remove the two screws and locknuts securing the handlebar and carefully (to avoid kinking the cables) rotate the handlebar so that the upper portion rests on the engine and the handlebar legs face to the rear of the unit.

GENERAL ENGINE MAINTENANCE

Perform the following engine maintenance for your engine according to the engine maintenance schedule and instructions in the separate Engine Owner's Manual:

Engine Oil Service

Check the engine oil level before starting the engine each day and check it after each 5 hours of continuous oper-

ation. Running the engine when it is low on oil will quickly ruin the engine.

Change the oil after every 25 hours of operation and even sooner when operating in extremely dirty or dusty conditions.

Air Cleaner Service

The engine air cleaner filters dirt and dust out of the air before it enters the carburetor. Operating the engine with a dirty, clogged air filter can cause poor performance and damage to the engine. Never operate the engine without the air cleaner installed. Inspect and service the air cleaner after every 25 operating hours, more often if operating in very dusty or dirty conditions. Refer to the Engine Owner's Manual for cleaning or replacement instructions.

Spark Plug Service

Inspect and clean or replace the spark plug after every 100 operating hours or annually. Refer to the Engine Owner's Manual for cleaning or replacement instructions.

Spark Arrester Screen Service

If the engine is equipped with a spark arrester screen, remove and clean it according to the time intervals and instructions in the Engine Owner's Manual.

Engine Cleaning

The engine must be kept clean to assure smooth operation and to prevent damage from overheating. Refer to the Engine Owner's Manual for specific cleaning instructions.

Carburetor/Governor Control Adjustments

The carburetor was adjusted at the factory for best operating speed. Refer to the Engine Owner's Manual for any adjustment information.

The governor controls the maximum safe operating speed and protects the engine and other moving parts from

damage caused by overspeeding. Do not tamper with the governor settings. Seek authorized service if you think an adjustment is required.

Throttle Control Adjustment

If the engine does not shut off when the throttle lever is moved to the stop position, or if the engine does not respond to various throttle settings, refer to the Engine Owner's Manual for service information.

OFF-SEASON STORAGE

When storing the trimmer/mower for extended periods, follow these procedures to ensure that the unit will be in good condition for future use.

- Store machine on a level surface.
- Thoroughly inspect the machine for any loose, broken or missing parts. Repair or replace parts as necessary.
- Perform recommended engine maintenance by following the engine storage instructions found in the Engine Owner's Manual. Be sure to protect the fuel lines, carburetor and fuel tank from gum deposits by removing fuel or by treating fuel with a fuel stabilizer (follow engine manufacturer's recommendations).

⚠ WARNING

- Never perform maintenance when engine is running or spark plug wire is connected, except when instructed to do so.
- Never store mower with fuel in fuel tank inside a building where fumes can reach an open flame or spark, or where ignition sources are present such as hot water and space heaters, furnaces, clothes dryers, stoves, electric motors, etc. Make sure engine is cool before storing.
- Drain gasoline outdoors into an approved container. Do not smoke and keep fuel away from open flame.

Failure to follow these instructions will result in serious personal injury or property damage.

- Change engine oil.
- Clean any dirt, grass or chaff from the air cooling system intake area and other parts of the engine.
- Check nuts, bolts, other hardware for tightness. Replace missing hardware.
- On an electric start model, remove key from keyswitch. Charge battery for 24 hours *before* and *after* storage.
- Disconnect spark plug wire from spark plug. Prevent wire from touching spark plug by placing wire away from spark plug.

BATTERY RECHARGING (Models with electric start feature)

⚠ DANGER

- **Wet conditions can cause an electric shock hazard during battery charging. Avoid wet conditions when charging.**
- **Recharging the battery with improper equipment could cause a battery explosion. Use only the battery charger shipped to you. All parts must be fully stopped and the spark plug wire disconnected and moved away from the spark plug.**

Failure to comply could result in personal injury or property damage.

Recharge the battery before and after storing the unit for more than three weeks.

The engine must be stopped and the area in which recharging will take place must be dry.

1. Connect the small plug on the battery charger cord (A, Figure 5-8) to the wire harness plug (B) located near the keyswitch.
2. Plug the recharger box (C, Figure 5-8) into a grounded 120-Volt wall outlet.
3. Charge the battery for 24 hours. After charging, unplug the recharger box (C, Figure 5-8) from the wall outlet first, then disconnect the recharging line plugs (A and B, Figure 5-8).

BATTERY REPLACEMENT

If the battery no longer takes a charge, or if it is leaking or otherwise damaged, it must be replaced.

1. Tilt the debris shield forward.
2. Disconnect the negative (-) black wire first; then the positive (+) red wire.
3. A clamp secured with two screws holds the battery to the deck. Remove screw (D, Figure 5-9), then lift the battery from under the battery clamp.
4. Position the new battery under the clamp and replace screw (D).
5. Connect the red wire to the positive (+) red-coded battery terminal. Then, connect the black wire to the negative (-) black-coded battery terminal.

NOTE: Discard battery properly, as required by regulations in your area.

6. Close the debris shield.

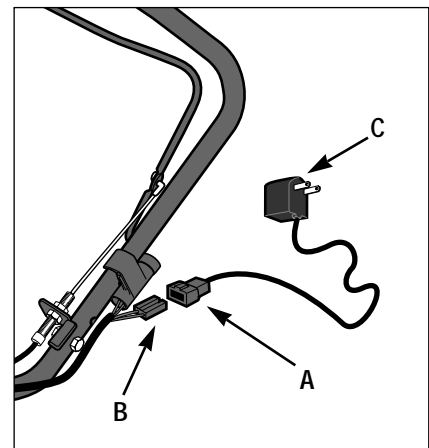

Figure 5-8: Use recharger supplied with unit.

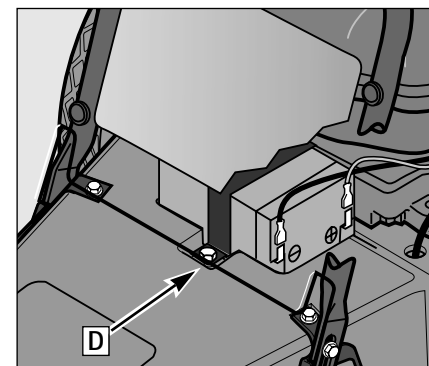
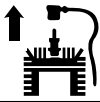

Figure 5-9: Battery replacement.

Section 5: Maintenance

WARNING



Before inspecting, cleaning or servicing the machine, shut off engine, wait for all moving parts to come to a complete stop, disconnect spark plug wire and move wire away from spark plug. Remove ignition key on electric start models.

Failure to follow these instructions can result in serious personal injury or property damage.

CHANGING TRIMMER LINES

The trimmer lines will wear with use and eventually require replacement. Also, you may wish to switch between the thinner and thicker gauge lines to handle different mowing conditions.

Replace the trimmer lines when they wear to the point that trimming and mowing projects take too long and require too much maneuvering of the machine. A good rule of thumb is to change the lines when they reach half their original length.

Use the extra-heavy duty gauge (.155" diameter) line when cutting thick, tough growth. The thinner gauge (.130" diameter) line is for use in less demanding conditions, and is also recommended for use near trees or ornaments to help prevent girdling (cutting of bark).

To Change Trimmer Lines:

1. Stop engine, allow all parts to stop moving and then disconnect the spark plug wire. Remove the ignition key on electric start models. DO NOT tip the machine. DO NOT touch the metal wear cup on the bottom of the spindle head. This surface may be hot.

NOTE: The two line holders on the trimmer head are permanently secured by a screw and a nut. Do not attempt to remove the line holders as it is not necessary to remove them in order to change the trimmer lines.

2. The trimmer lines can be changed when the trimmer head is in contact with the ground. If necessary, you may tip the unit back slightly for a better view. However, do not tip the unit all the way back or motor oil may flow to the exhaust area and the engine may smoke for several seconds when started.

3. Three different line installation patterns are available, as shown in Figures 5-10, 5-11 and 5-12.

4. Simply feed the line through the loops of the line holder as shown. An equal amount of line should project out from each side of the line holder, creating an overall 22" wide cutting swath. You may offset both trimmer lines somewhat to increase the cutting swath up to 25" wide. However, DO NOT offset the line so that the overall cutting swath is greater than 25". See Warning statement at right.

IMPORTANT: Whether replacing one or both lines, they must both be .130" or .155" in diameter.

5. Repeat steps 2 through 4 to replace the second trimmer line.

WARNING

Offsetting the trimmer lines causes the lines to rotate faster than when they project an equal length on each side. This increases the chance of loose materials being dislodged and propelled at high speeds.

Failure of the operator to wear safety goggles and appropriate clothing and to keep bystanders away can result in severe personal injury or property damage.

Figure 5-10: Use this single line, easy-loop pattern for all but the more difficult cutting conditions.

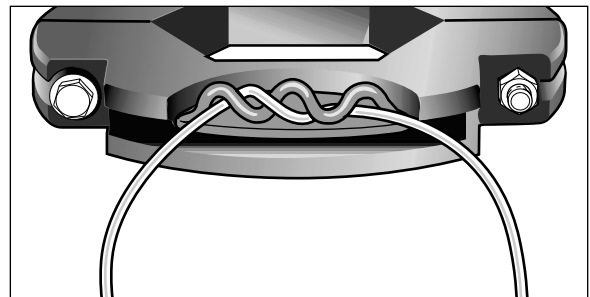

Figure 5-11: If the lines should loosen while trimming (especially in more difficult conditions), add a simple reverse loop. Note that this pattern will result in a slightly narrower overall cutting swath.

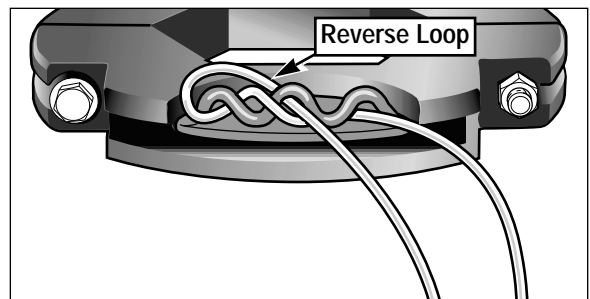
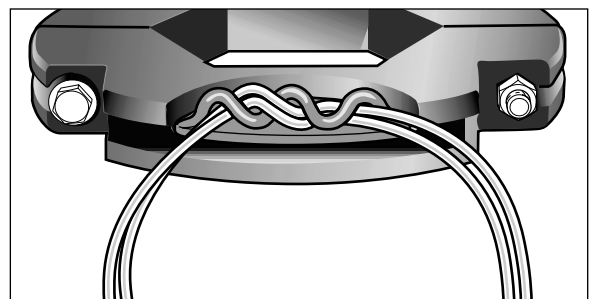

Figure 5-12: For more difficult cutting conditions, use two of the thicker gauge (.155" diameter) lines in each line holder. Follow the installation pattern shown in Figure 5-10.



Section 5: Maintenance

TROUBLESHOOTING

Before performing any of the corrections in this Troubleshooting Chart, refer to the appropriate information contained in this Manual or the Engine Owner's Manual for the correct safety precautions and servicing procedures. Contact your local authorized Engine Service Dealer for engine service. Contact your local authorized dealer for service problems with the machine.

PROBLEM	POSSIBLE CAUSE	CORRECTION
Engine does not start.	<ol style="list-style-type: none"> 1. Spark plug wire disconnected. 2. Defective or incorrectly gapped spark plug. 3. Fuel tank empty. 4. Dirty carburetor or fuel line. 5. Dirty air cleaner. 6. Carburetor out of adjustment. 7. Engine flooded. 8. Engine Throttle Lever in incorrect position. 9. Stale gasoline. 10. Defective Engine Throttle Lever. 11. Dirt or water in fuel tank. 	<ol style="list-style-type: none"> 1. Reconnect wire. 2. Inspect/replace spark plug. 3. Add fuel. 4. Clean carburetor or fuel line. 5. Clean or replace. 6. Adjust carburetor. See Engine Service Dealer. 7. Wait several minutes before starting. 8. Move Throttle Lever to FAST position. 9. Drain old fuel and add fresh fuel. 10. See Engine Service Dealer. 11. See Engine Service Dealer.
Engine runs poorly.	<ol style="list-style-type: none"> 1. Bad spark plug. 2. Dirty air filter. 3. Carburetor out of adjustment. 4. Stale fuel. 5. Dirt or water in fuel tank. 6. Engine cooling system clogged. 	<ol style="list-style-type: none"> 1. Inspect/replace spark plug. 2. Clean or replace. 3. Adjust carburetor. See Engine Service Dealer. 4. Drain and replace fuel mixture. 5. See Engine Service Dealer. 6. Clean fins.
Engine overheats.	<ol style="list-style-type: none"> 1. Engine cooling system clogged. 2. Carburetor out of adjustment. 	<ol style="list-style-type: none"> 1. Clean air cooling areas and behind debris shield. 2. Adjust Carburetor. See Engine Service Dealer.
Engine does not shut off.	<ol style="list-style-type: none"> 1. Throttle control misadjusted. 	<ol style="list-style-type: none"> 1. See Engine Service Dealer.
Poor mowing performance.	<ol style="list-style-type: none"> 1. Line length is too short or too long. 2. Cutting height is too high or low for height of grass being cut. 3. Engine not set at FAST speed. 	<ol style="list-style-type: none"> 1. Adjust line length to 18" long. When less than 1/2 this length, replace the line. 2. Adjust cutting height to approximately 1/3 of the length of the grass. 3. Move Engine Throttle Lever to FAST (Rabbit).
Trimmer/Mower vibrates.	<ol style="list-style-type: none"> 1. Trimming head mounting bolt loose. 2. Line lengths are substantially different. 3. Loose nuts or bolts. 4. Broken spindle head or trimmer head. 	<ol style="list-style-type: none"> 1. Tighten bolt. 2. Adjust lines to approximately equal lengths. 3. Check all bolts and nuts, including engine bolts. 4. Replace broken part.
Trimmer head does not retain line.	<ol style="list-style-type: none"> 1. Incorrect line installation for mowing conditions. 	<ol style="list-style-type: none"> 1. See <i>Changing Trimmer Lines</i> in Section 5.
Trimmer Head does not retain height setting.	<ol style="list-style-type: none"> 1. Head bolts may be loose. 2. Head is worn. 	<ol style="list-style-type: none"> 1. Tighten head bolts to 75 in/lbs. 2. Replace head assembly.
Electric Starter does not start engine (electric start models only).	<ol style="list-style-type: none"> 1. Wires to battery unconnected. 2. Battery not charged. 3. Broken wire in wiring harness. 4. Malfunctioning starter motor. 	<ol style="list-style-type: none"> 1. Reconnect wires. 2. Charge battery. 3. Replace wiring harness. 4. Contact local engine dealer.
Battery does not charge during engine operation (electric start models).	<ol style="list-style-type: none"> 1. Broken wire in engine recharging circuit. 2. Malfunctioning engine recharging system. 3. Dead battery. 	<ol style="list-style-type: none"> 1. See Engine Service Dealer. 2. See Engine Service Dealer. 3. Replace battery.
Battery charger does not charge battery (electric start models).	<ol style="list-style-type: none"> 1. Broken battery lead. 2. Broken battery charger wire. 3. Dead battery. 	<ol style="list-style-type: none"> 1. Replace battery lead. 2. Replace battery charger. 3. Replace battery.

DRAWING NO. 1

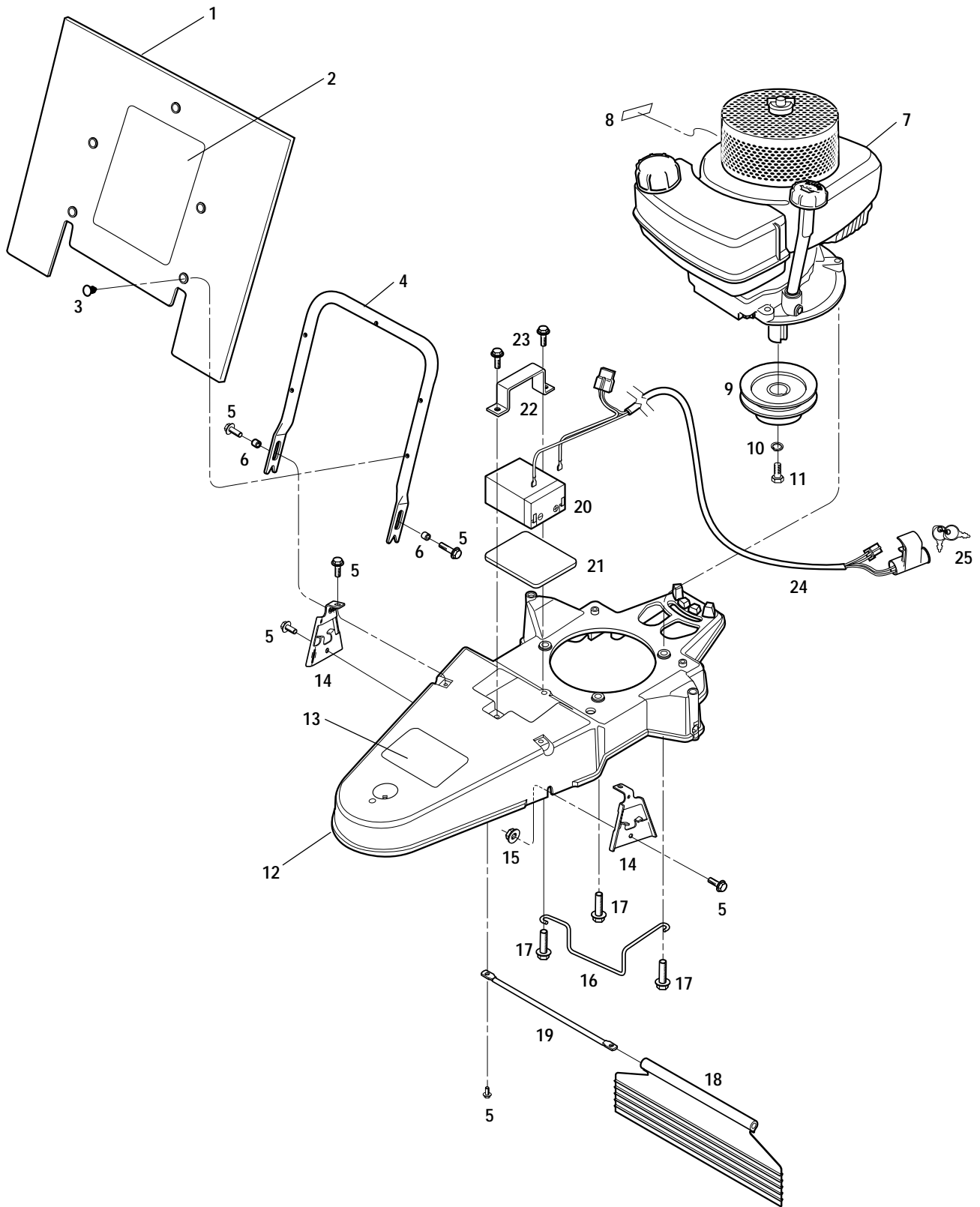

PARTS LIST – DRAWING NO. 1

Ref. #	Part #	Description	Qty.	Ref. #	Part #	Description	Qty.
1	1917765	Debris Guard	1	13	1918115	Decal-Warning	1
2	1918082	Decal-Logo (B)	1	14	1917144001	Hood Bracket	2
	1904401	Decal-Logo (A)	1	15	1186389	Flange Lock Nut, 1/4-20	2
3	1915290	Push-in Fastener.....	5	16	1917574	Belt Guide	1
4	1917407001	Debris Guard Support.....	1	17	1768194	Hex Hd. Screw, 3/8-16 x 1-1/2	3
5	1754128	Hex Flange Screw, 1/4-20 x 3/4	8	18	1917154	Deflector Flap.....	1
6	1915320	Spacer	2	19	1917155	Rod.....	1
7	*	Engine.....	1	20	1909647	Battery (A)	1
8	1904511	Decal-Hot Surface Warning	1	21	1915268	Battery Pad (A)	1
9	1917727	Engine Pulley.....	1	22	1915204001	Battery Clamp (A)	1
10	1100243	Spring Lock Washer	1	23	90063	Hex Flange Screw (A), 5/16-18 x 1	2
11	1100009	Hex Hd. Screw, 3/8-24 x 1, Grade 5	1	24	1918055	Wire Harness (A)	1
12	1918228	Deck (Incl. Ref. 13).....	1	25	96520	Ignition Key (A).....	2

(A) Model 52058

(B) Model 52057

* Order parts from your local authorized engine dealer. Refer to engine for model/type number.

DRAWING NO. 2

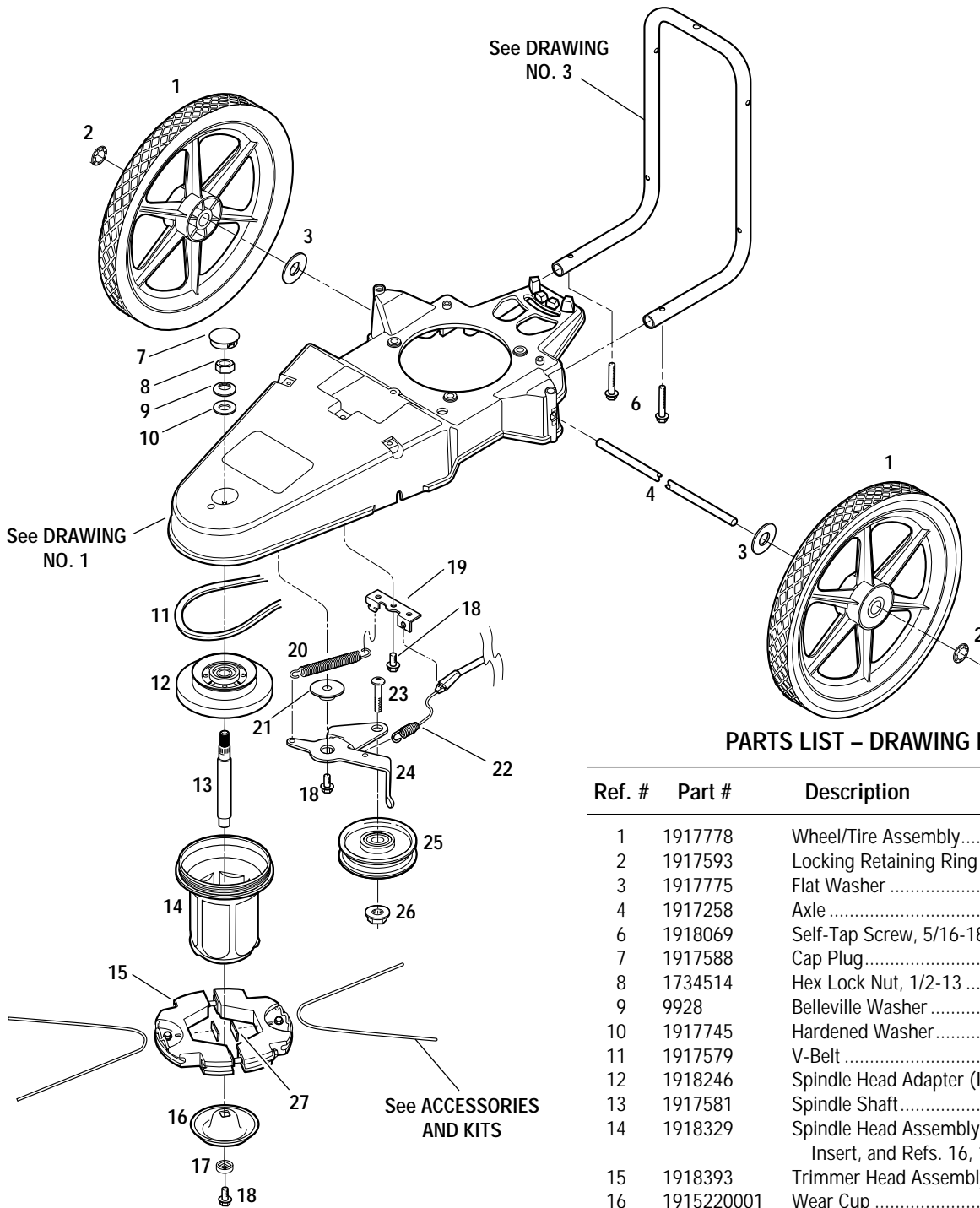

PARTS LIST – DRAWING NO. 2

Ref. #	Part #	Description	Qty.
1	1917778	Wheel/Tire Assembly.....	2
2	1917593	Locking Retaining Ring.....	2
3	1917775	Flat Washer.....	2
4	1917258	Axle.....	1
6	1918069	Self-Tap Screw, 5/16-18 x 2.....	2
7	1917588	Cap Plug.....	1
8	1734514	Hex Lock Nut, 1/2-13.....	1
9	9928	Belleville Washer.....	1
10	1917745	Hardened Washer.....	1
11	1917579	V-Belt.....	1
12	1918246	Spindle Head Adapter (Incl. Bearing).....	1
13	1917581	Spindle Shaft.....	1
14	1918329	Spindle Head Assembly (Incl. Bearing, Insert, and Refs. 16, 17, 18).....	1
15	1918393	Trimmer Head Assembly (Incl. Ref. 27).....	1
16	1915220001	Wear Cup.....	1
17	1917599	Square Washer.....	1
18	1724491	Self-Tap Screw, 5/16-18 x 3/4.....	3
19	1917573	Cable Bracket.....	1
20	1910849	Idler Spring.....	1
21	1917746	Flat Washer.....	1
22	1917589	Control Cable - Trimmer Head.....	1
23	1910857	Button Hd. Screw, 3/8-16 x 1-1/2.....	1
24	1917572	Idler Arm.....	1
25	1910855	Idler Pulley.....	1
26	1186393	Flange Lock Nut, 3/8-16.....	1
27	1918332	Rubber Shim Kit (2 shims per kit).....	1

DRAWING NO. 3

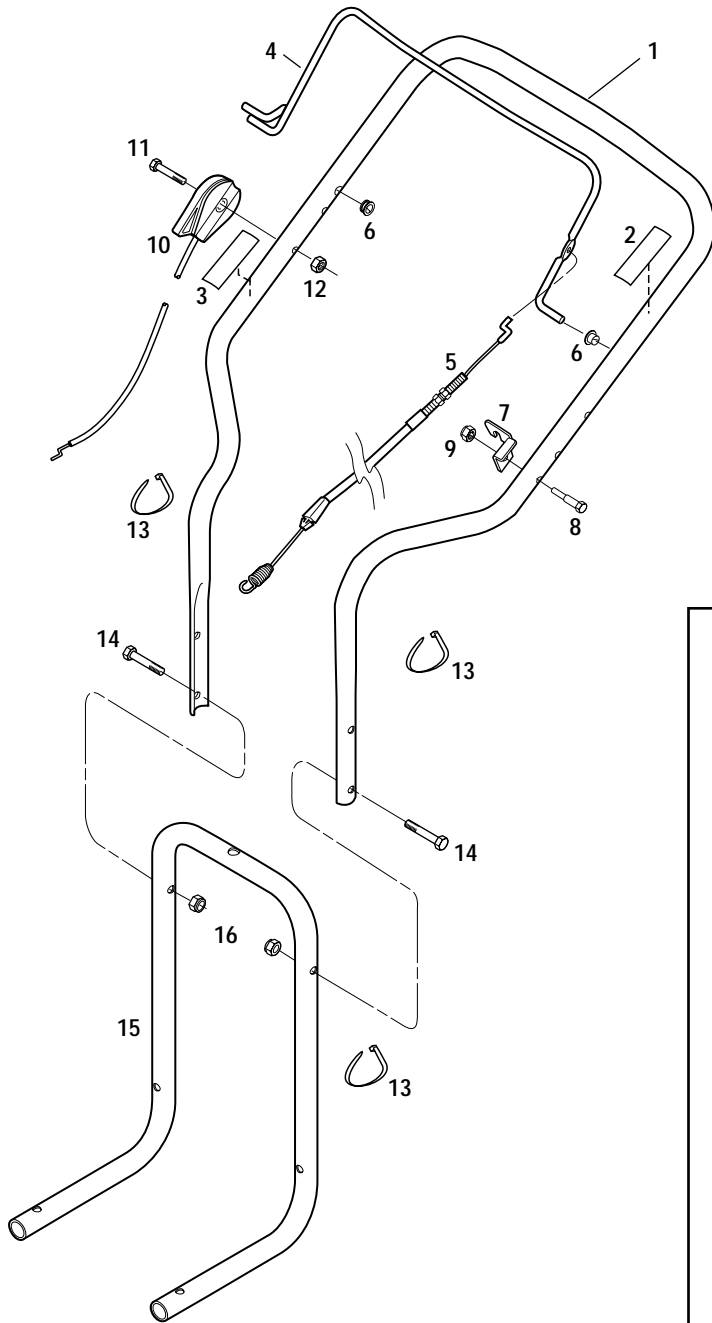

PARTS LIST – DRAWING NO. 3

Ref. #	Part #	Description	Qty.
1	1918283	Upper Handlebar (Incl. Refs. 2 & 3)	1
2	1915889	Decal–Bail Engage/Disengage	1
3	1918304	Decal–Throttle	1
4	1918070001	Control Bail–Trimmer Head	1
5	1917589	Cable Assembly–Trimmer Head	1
6	1908677	Bushing	2
7	1749977001	Cable Bracket	1
8	1983658	Hex Hd. Screw, 1/4-20 x 1-1/8	1
9	1185814	Hex Flange Lock Nut, 1/4-20	1
10	1918081	Throttle Lever & Cable Assembly	1
11	1100807	Hex Hd. Screw, 1/4-20 x 2	1
12	1110106	Hex Lock Nut, 1/4-20	1
13	1763682	Cable Tie.....	3
14	1100799	Hex Hd. Screw, 5/16-18 x 1-1/2	2
15	1917145001	Handlebar Support	1
16	1732499	Hex Lock Nut, 5/16-18	2

ACCESSORIES AND KITS

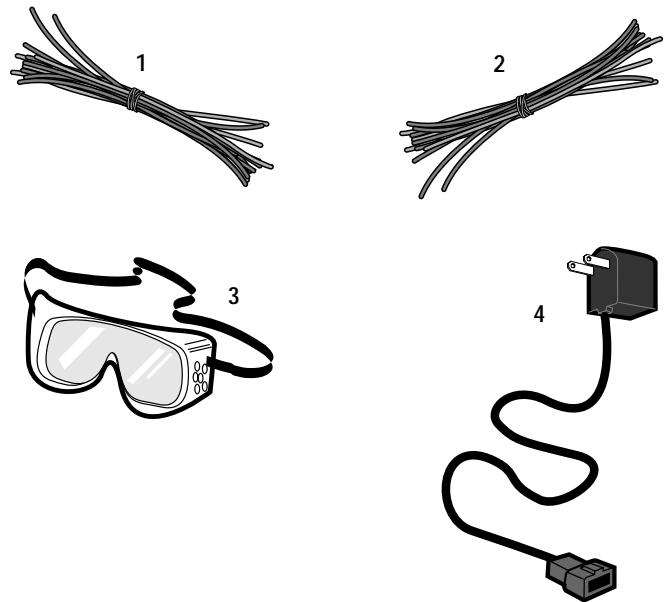

Ref. #	Part #	Description	Qty.
1	1904476	Trimmer String Kit, .155" diameter line (24 pieces)	N/I
2	1904477	Trimmer String Kit, .130" diameter line (24 pieces)	N/I
3	1917598	Safety Goggles.....	1
4	1768449	Battery Charger (for electric start model) .	1

N/I Not included with unit, order separately.

CUSTOMER SERVICE INFORMATION

Owner Registration Card

Please fill out and mail the enclosed owner registration card. The purpose of this card is to register each unit at the factory in order to keep the owner informed with informational bulletins and safety literature.

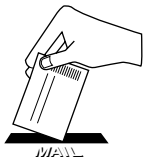

Warranty Service

The warranty statement is included in the unit's literature package.

Model/Serial Numbers

A Model Number / Serial Number decal is located on the side of the deck. For ready reference, record these numbers in the spaces below.

Model Number:

Serial Number:

IMPORTANT:

Left and right sides of the unit are determined by standing behind the unit, in the operator's position, and facing in the direction of forward travel.

NOTICE:

We reserve the right to change specifications, add improvements or discontinue the manufacture of any of our equipment without notice or obligation to purchasers of our equipment.

WARNING

We urge using only genuine replacement parts, which meet all the latest requirements. Replacement parts manufactured by others could present safety hazards, even though they may fit on the unit.

Customer Service and Technical Service

If you have questions or problems with the unit, contact your local dealer or call or write to the factory. (When calling or writing, provide the model/serial number of the unit.)



Replacement Parts

Factory specified replacement parts are available from your authorized dealer or directly from the factory. When ordering parts, be sure to provide the following:

- Model/Serial Numbers of unit.
- Part number of the part needed.
- Part description.
- Quantity needed.

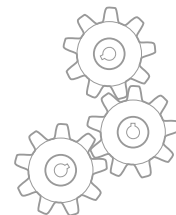

NOTE: All replacement parts must conform to our rigid quality specifications. Although some parts we provide may vary slightly in shape, color or texture from the original parts, any variations will not affect the fit or performance of these parts on your unit.

Engine Service and Repair

For engine service or repair, contact your nearest authorized engine dealer (look in the Yellow Pages under "Engines-Gasoline"). The engine is warranted by the engine manufacturer. Any unauthorized work performed on the engine during the warranty period may void this warranty. For complete details on the engine warranty, refer to the Engine Owner's Manual.

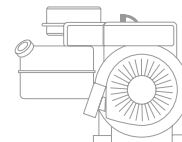

Authorized Dealer Information

If you purchased your unit from an authorized dealer, record the dealer's address and phone number below for ready reference:

Dealer Name: _____

Address: _____

Phone: _____

For customer assistance, contact your nearest authorized dealer or:

GARDEN WAY INCORPORATED • 1 Garden Way • Troy, New York 12180
Customer Service: 1-800-437-8686 • Technical Service: 1-800-520-5520 • Parts Service: 1-800-648-6776
• FAX: (518) 391-7332 • WEB SITE: www.troybilt.com

Outside the United States and Canada:
Customer Service: (518) 391-7007 • Technical Service: (518) 391-7008 • Parts Service: (518) 391-7006 • FAX (518) 391-7332