

PEAVEY ELECTRONICS

Impulse® 100

Frequency Response, 1 meter on-axis, swept-sine in anechoic environment:

74 Hz to 18 kHz (± 3 dB)

Usable Low Frequency Limit (-10 dB point):

57 Hz

Power Handling:

Full Range:

175 W continuous (EIA RS-426A)

350 W program

700 W peak

Sound Pressure Level, 1 Watt, 1 meter in anechoic environment:

Full Range:

96 dB SPL, (2.83 VRMS input)

Maximum Sound Pressure Level (1 meter):

Full Range:

118 dB SPL continuous

125 dB SPL peak

Radiation Angle measured at -6 dB point of polar response:

500 Hz to 1.6 kHz:

Horiz. $115^\circ \pm 25^\circ$

Vert. $135^\circ \pm 25^\circ$

1.6 kHz to 5 kHz:

Horiz. $75^\circ \pm 15^\circ$

Vert. $80^\circ \pm 35^\circ$

5 kHz to 16 kHz:

Horiz. $85^\circ \pm 15^\circ$

Vert. $40^\circ \pm 5^\circ$

Directivity Factor, Q (Mean):

9.37 ± 5.62

Directivity Index, Di (Mean):

$9.00 \text{ dB} \pm 2.49 \text{ dB}$

Transducer Complement:

Low Frequency Section:

1x 10" Long-throw Heavy Duty Woofer

High Frequency Section:

1x 14XT™ 1in. Exit/34mm Voice Coil Titanium Diaphragm Compression Driver

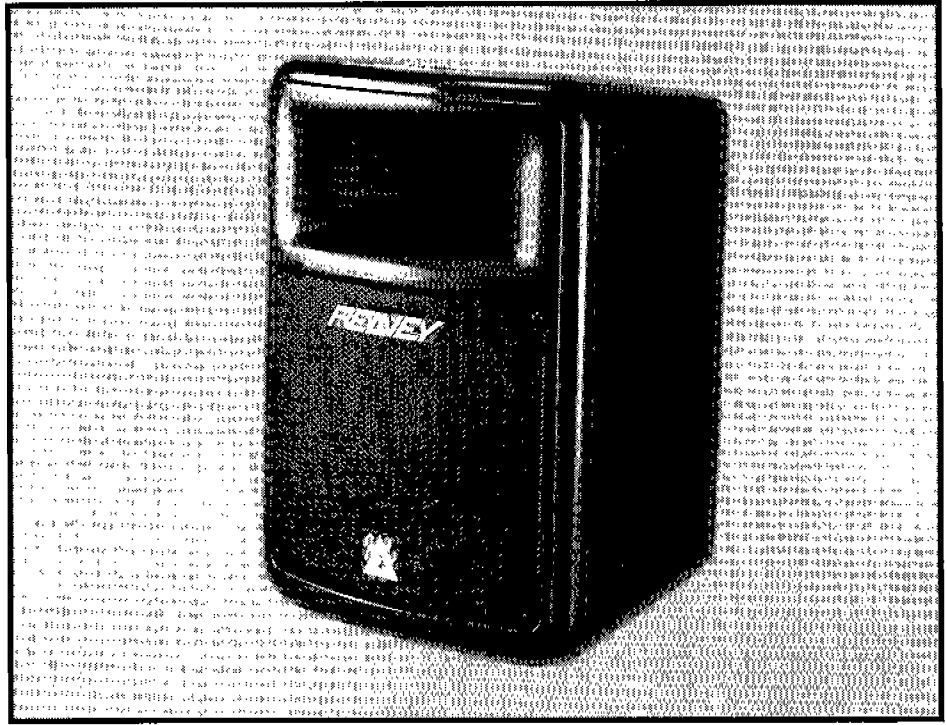

Box Tuning Frequency:

Low Frequency Section: 75 Hz

High Frequency:

12 dB/octave (2nd Order) with padding and CD Horn EQ

Harmonic Distortion:

1% rated power

2nd Harmonic:

100 Hz: 0.57%

1 kHz: 0.25%

3rd Harmonic:

100 Hz: 0.62%

1 kHz: 0.54%

10% rated power

2nd Harmonic:

100 Hz: 1.35%

1 kHz: 1.32%

3rd Harmonic:

100 Hz: 0.39%

1 kHz: 1.17%

Crossover Frequency (internal passive):

Low Frequency — High Frequency:

2,200 Hz

Crossover Slope:

Low Frequency:

12 dB/octave (2nd order)

Impedance (Z):

Full Range:

Nominal: 8.0 Ω

Minimum: 6.7 Ω

Input Connections:

Two 1/4" Phone Jacks (in parallel)

Enclosure Materials and Finish:

1/4 in. Polypropylene Finished in Textured Molded Surface

Mounting provisions:

Stand mounting via molded-in mount, Flying via (8) 1/4"-20 Threaded Mounting Points, 4 each Top and Bottom, with use of Versamount™ 35. Floor use via four rubber feet.

Dimensions (H x W x D):

Front:

18.88 in. x 14.00 in. x 13.13 in.

479 mm x 356 mm x 333 mm



Rear:

17.63 in. x 8.25 in. x 13.13 in.
448 mm x 210 mm x 333 mm

Optional Accessories:

Versamount™ 35, Impulse™ 100 Array Bracket

Net Weight:

29 lbs. (13.2 kg)

Features

- 175 W Continuous, 700 W Peak
- Sound Guard™ II
- 10" Long-throw Heavy Duty Woofer
- 14XT™ 1.4" Titanium Compression Driver
- Handle and Stand Mount
- Top and Bottom Flying Point Inserts
- Molded-In Horn has exceptionally smooth response and wide dispersion

DESCRIPTION

The Impulse® 100 is a two-way full-range speaker system engineered to provide ultra-high performance in a portable, very compact package. The enclosure utilizes high-impact polypropylene in an injection-molded plastic trapezoidal shape, along with a coated perforated metal grille to offer a cosmetically elegant yet durable system.

The two-way system is comprised of a 10" long-throw heavy duty woofer with a special suspension for excellent excursion capability. The 14XT™ compression driver features a 1.4" titanium diaphragm, and is coupled to an extremely smooth and well controlled constant directivity horn, with a coverage pattern of 90 degrees by 40 degrees, that is molded into the enclosure. Input connection to the system is made via two 1/4" phone jacks connected in parallel. The internal passive crossover features Sound Guard™ II to protect the tweeter, and utilizes high performance components and an advanced topology crossover to provide high power handling and a smooth yet clear response. The optimal integration of the crossover with

the selected drivers results in a smooth frequency response from 74 Hz to 18 kHz, and a clarity in the midrange that is superlative.

The free-flow vented cabinet offers mounting point inserts top and bottom as well as a molded-in stand adapter and a top rear handle for maximum utility and ease of use.

FREQUENCY RESPONSE

This measurement is useful in determining how accurately a given unit reproduces an input signal. The frequency response of the Impulse® 100 is measured at a distance of 1-meter using a 1 watt (into the nominal impedance) swept-sine input signal. As shown in Figure 1, the selected drivers in the Impulse® 100 combine to give a smooth frequency response from 74 Hz to 18 kHz.

DIRECTIVITY

Beamwidth is derived from the -6 dB points from the polar plots (see Figure 3) which are measured in a whole space anechoic environment. Q and Directivity Index are plotted for the on-axis measurement position. These are specifications that provide a reference to the coverage characteristics of the unit. These parameters provide insight for proper placement and installation in the chosen environment. The blending of the components of the Impulse® 100 exhibits a desirable beamwidth and directivity (Figure 3 and 4) suitable for sound reinforcement applications.

POWER HANDLING

There are many different approaches to power handling ratings. Peavey Electronics rates this unit's system power handling using the EIA Standard RS-426A, Loudspeaker Power Rating, Full Range. This power rating standard uses a shaped noise signal that is similar to typical music in terms of thermal stress and mechanical stress. In-house power tests of various types are also performed to help assure component

and system reliability. This rating is contingent on having a minimum of 3 dB of amplifier headroom available so as to ensure that clipping does not occur.

HARMONIC DISTORTION

Second and third harmonic distortions vs. frequency are plotted in Figures 5 and 6 for two power levels. Ten percent (10%) of rated input power and either one percent (1%) of rated input power or one watt, whichever is greater. Distortion is read from the graph as the difference between the fundamental signal (frequency response) and the desired harmonic. As an example, a distortion curve that is down 40 dB from the fundamental is equivalent to 1% distortion.

MOUNTING

Caution: Before attempting to suspend this speaker, consult a certified structural engineer. Speaker can fall from improper suspension, resulting in serious injury and property damage. Do not suspend or mount any other product or device from this enclosure! Maximum enclosure angle 45°. Use only the correct mating hardware. All associated rigging is the responsibility of others.

ARCHITECTURAL AND ENGINEERING SPECIFICATIONS

The loudspeaker system shall have an operating bandwidth of 74 Hz to 18 kHz. The nominal output level shall be 96.0 dB when measured at a distance of one meter with an input of one watt. The nominal impedance shall be 8.0 ohms. The maximum continuous power handling shall be 175 watts, maximum program power of 350 watts and a peak power input of at least 700 watts, with a minimum amplifier headroom of 3 dB. The nominal radiation geometry shall be 90 degrees in the horizontal plane and 40 degrees in the vertical plane. The outside dimensions shall be 18.88 inches high by 14.00 inches wide by 13.13 inches deep. The weight shall be 29 pounds. The loudspeaker system shall be a Peavey model Impulse® 100.

Exposure to extremely high noise levels may cause a permanent hearing loss. Individuals vary considerably in susceptibility to noise-induced hearing loss, but nearly everyone will lose some hearing if exposed to sufficiently intense noise for a sufficient time. The U.S. Government's Occupational and Health Administration (OSHA) has specified the following permissible noise level exposures:

Duration Per Day In Hours	Sound Level dBA, Slow Response
8	90
6	92
4	95
3	97
2	100
1 1/2	102
1	105
1/2	110
1/4 or less	115

According to OSHA, any exposure in excess of the above permissible limits could result in some hearing loss. Ear plugs or protectors to the ear canals or over the ears must be worn when operating this amplification system in order to prevent a permanent hearing loss, if exposure is in excess of the limits as set forth above. To ensure against potentially dangerous exposure to high sound pressure levels, it is recommended that all persons exposed to equipment capable of producing high sound pressure levels such as this amplification system be protected by hearing protectors while this unit is in operation.

Impulse® 100

Q & Directivity Index

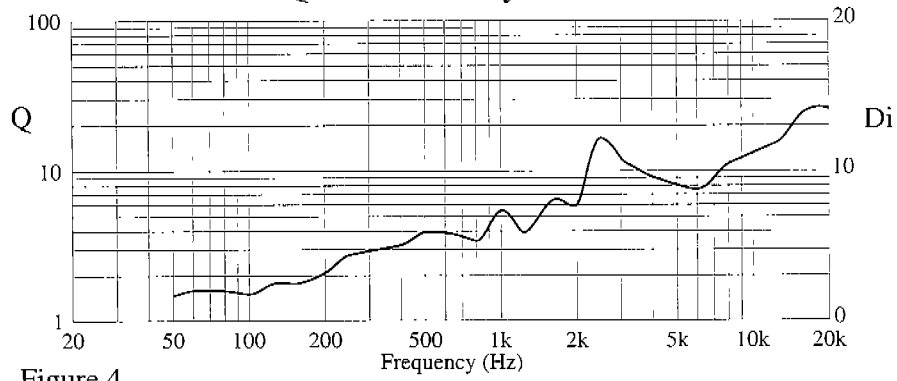

Figure 4

Harmonic Distortion at 1/100 Rated Power

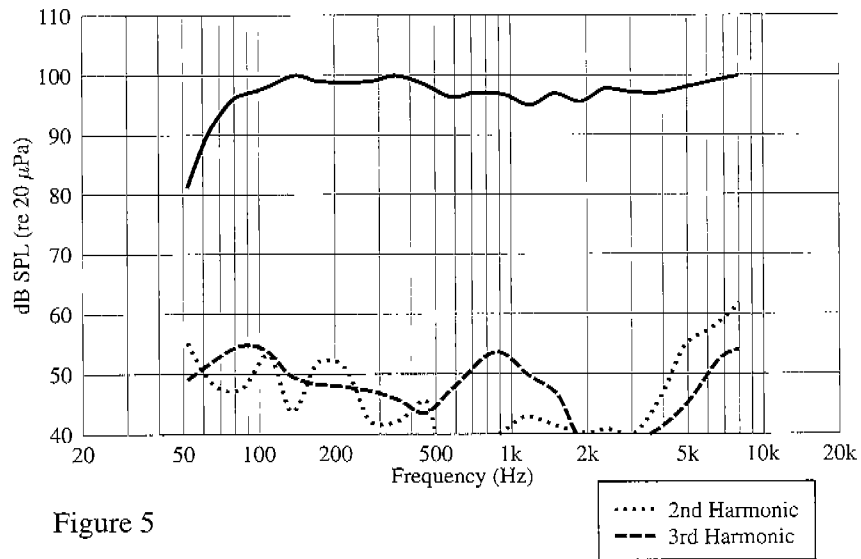

Figure 5

Harmonic Distortion at 1/10 Rated Power

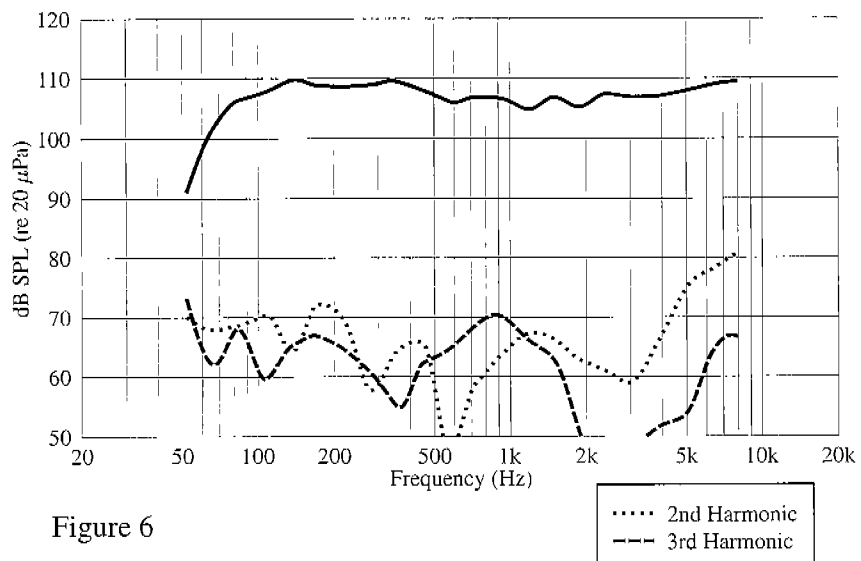

Figure 6

Impulse® 100

Amplitude Response (1W 1m On-Axis)

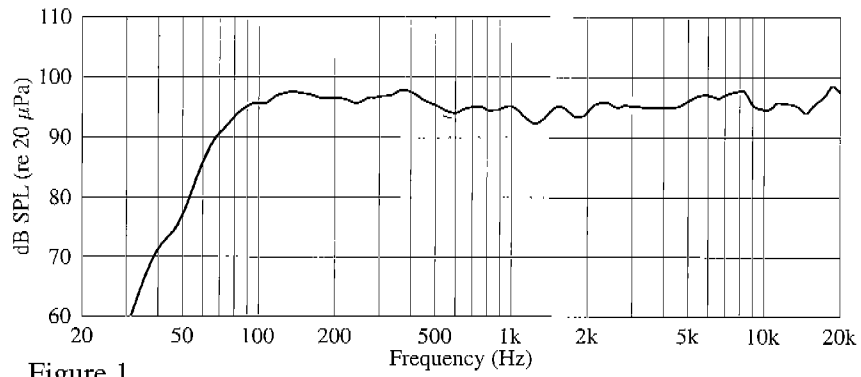

Figure 1

Impedance

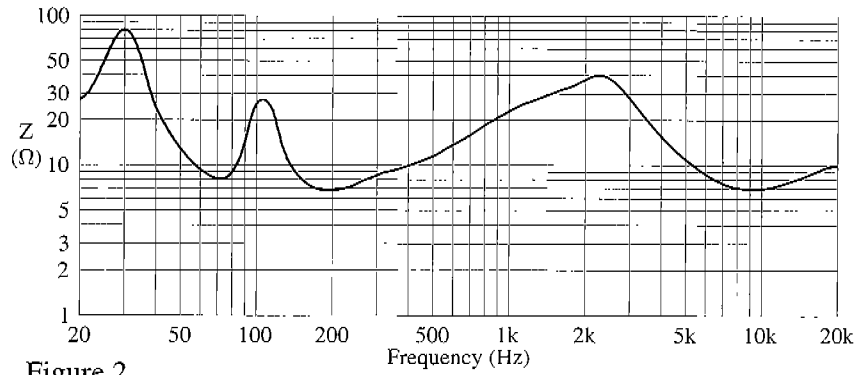

Figure 2

Beamwidth

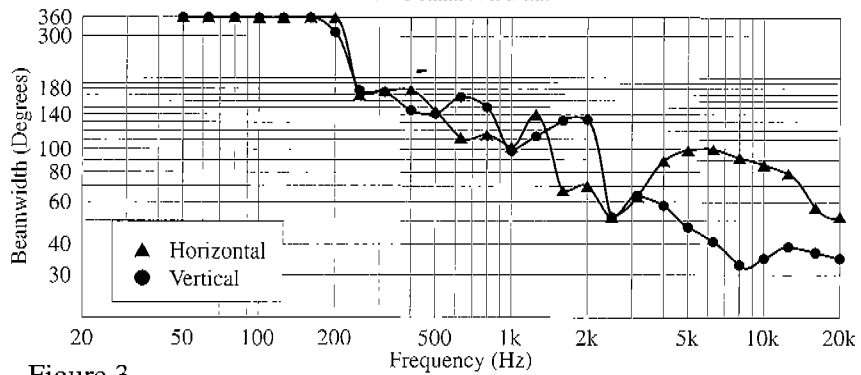
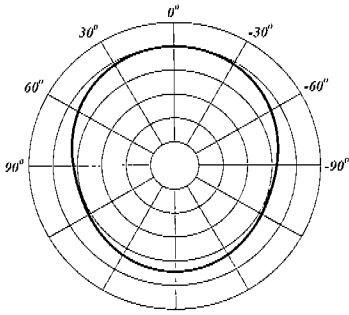

Figure 3

Impulse® 100
HORIZONTAL POLAR PATTERNS

1/3 octave averaged, plotted on ISO 1/3 octave centers from 200 Hz to 16 kHz



200 Hz

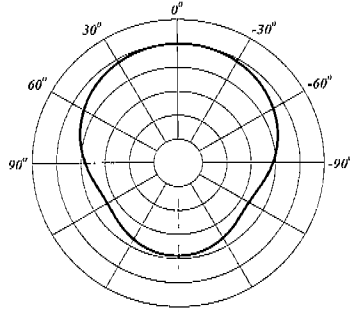

250 Hz

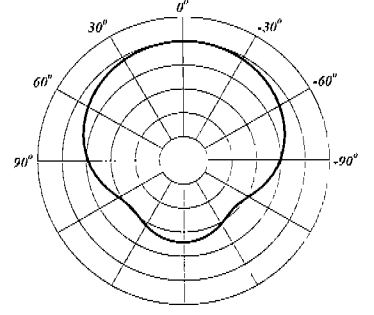

315 Hz

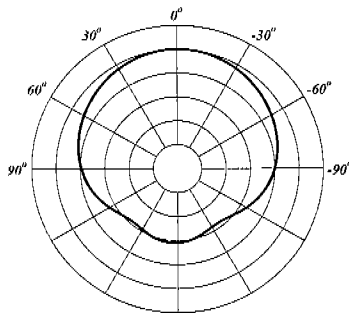

400 Hz

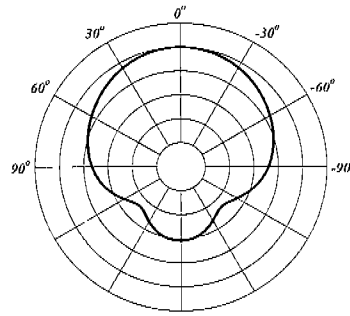

500 Hz

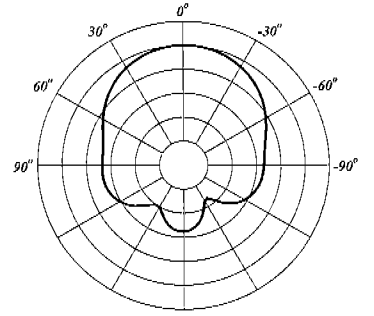

630 Hz

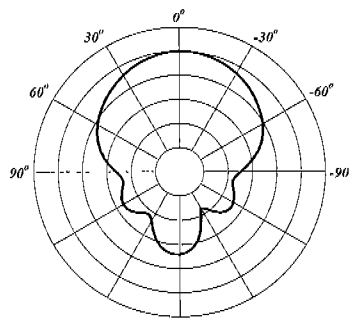

800 Hz

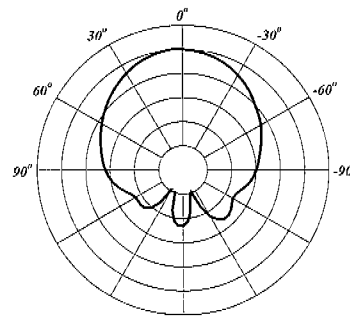

1 kHz

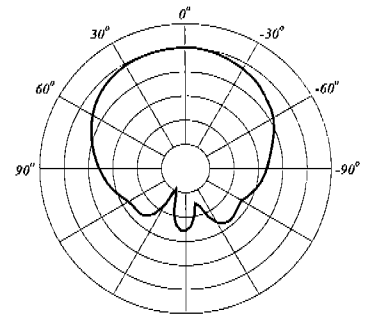

1.25 kHz

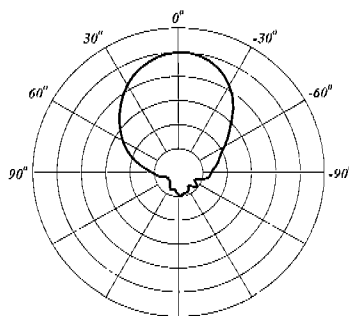

1.6 kHz

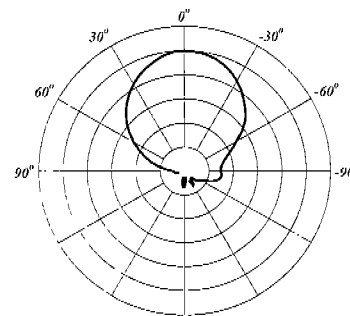

2 kHz

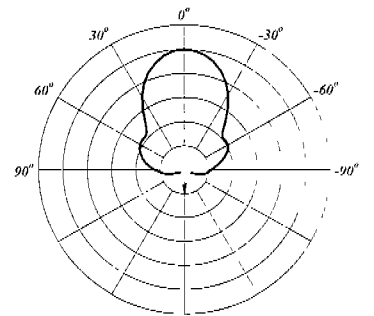

2.5 kHz

Impulse[®] 100
HORIZONTAL POLAR PATTERNS

1/3 octave averaged, plotted on ISO 1/3 octave centers from 200 Hz to 16 kHz

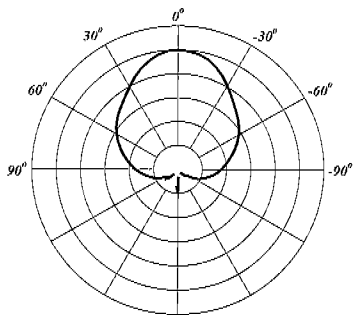

3.15 kHz

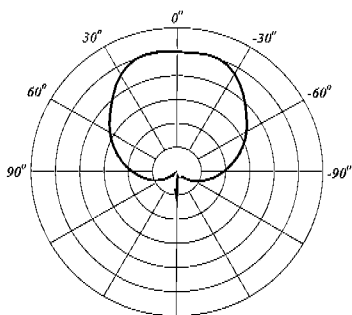

4 kHz

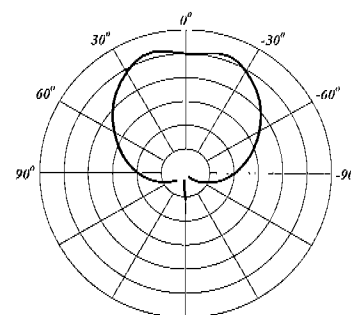

5 kHz

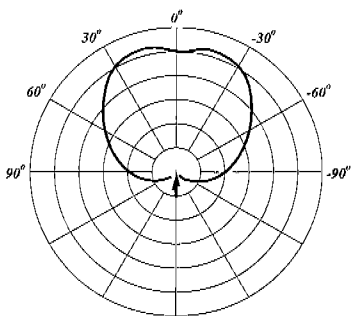

6.3 kHz

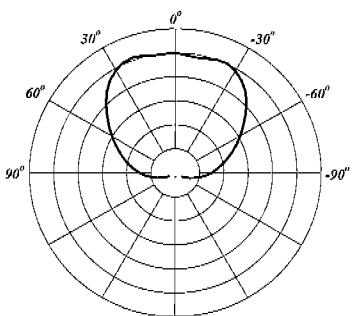

8 kHz

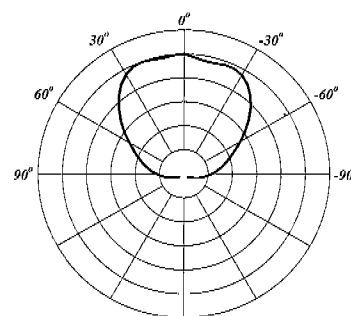

10 kHz

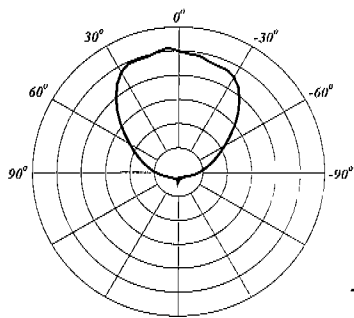

12.5 kHz

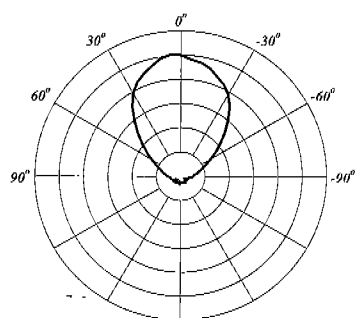

16 kHz

Impulse® 100
VERTICAL POLAR PATTERNS

1/3 octave averaged, plotted on ISO 1/3 octave centers from 200 Hz to 16 kHz

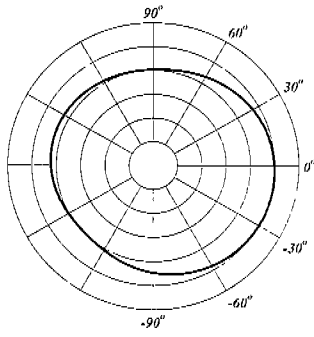

200 Hz

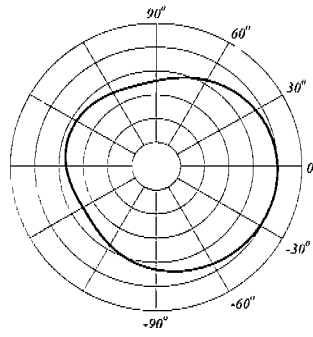

250 Hz

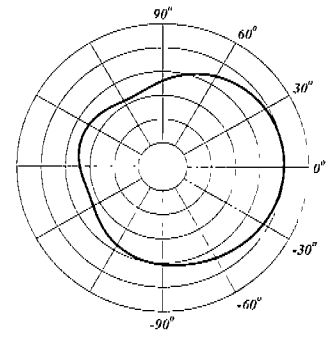

315 Hz

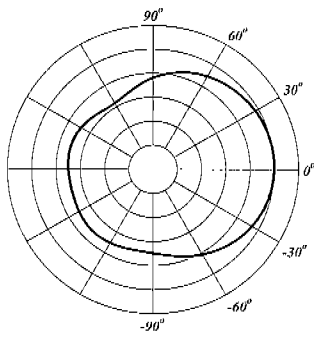

400 Hz

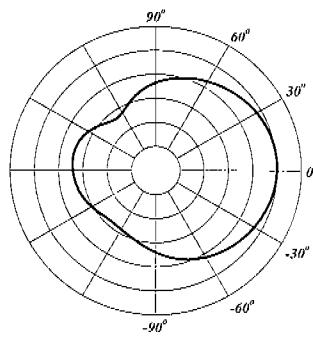

500 Hz

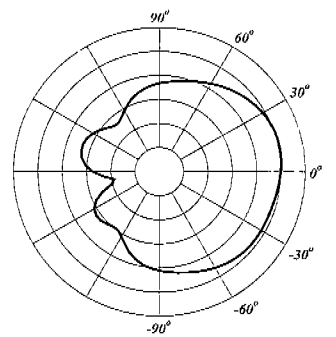

630 Hz

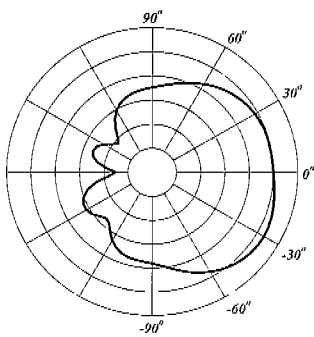

800 Hz

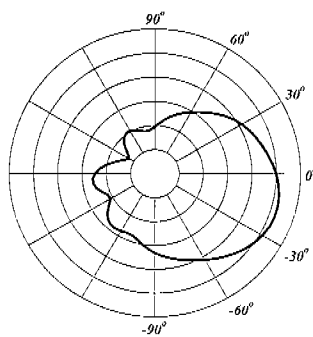

1 kHz

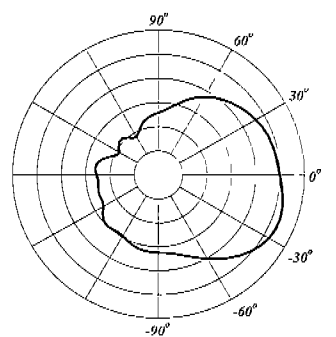

1.25 kHz

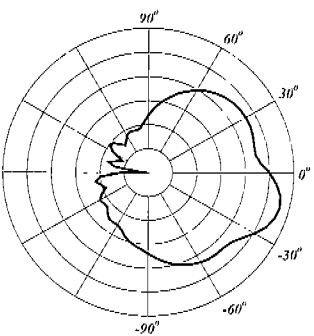

1.6 kHz

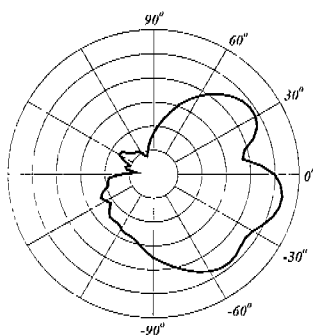

2 kHz

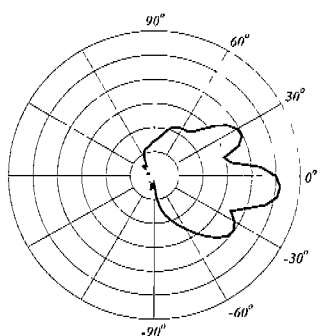

2.5 kHz

Impulse® 100
VERTICAL POLAR PATTERNS

1/3 octave averaged, plotted on ISO 1/3 octave centers from 200 Hz to 16 kHz

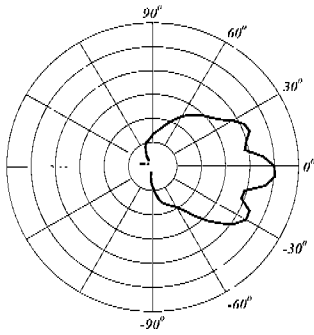

3.15 kHz

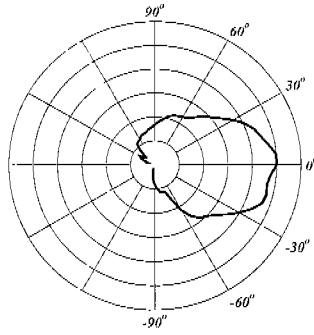

4 kHz

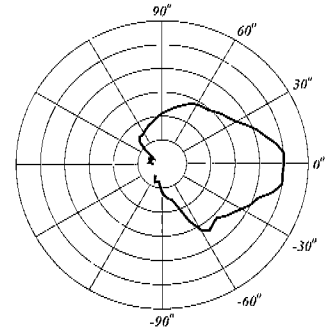

5 kHz

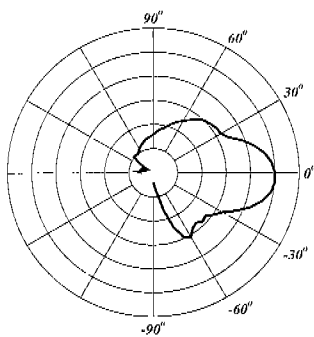

6.3 kHz

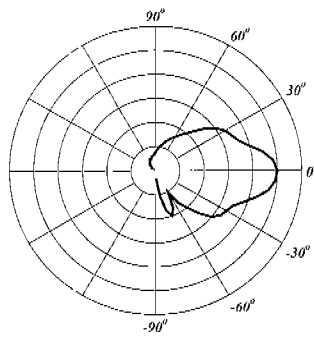

8 kHz

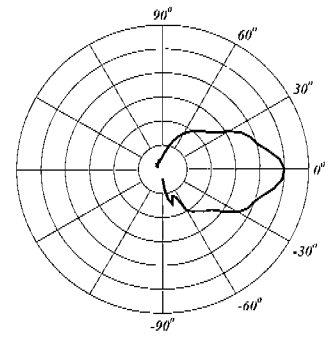

10 kHz

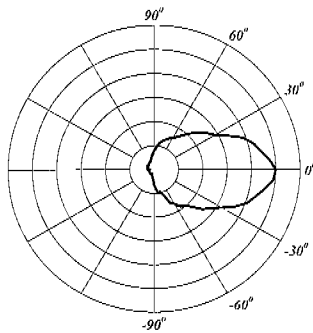

12.5 kHz

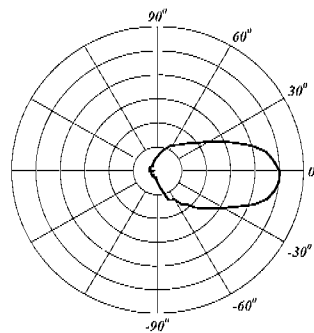

16 kHz

THREE + TWO LIMITED WARRANTY

NOTE: For details, refer to the warranty statement. Copies of this statement may be obtained by contacting Peavey Electronics Corporation, P.O. Box 2898, Meridian, Mississippi 39302-2898.

Features and specifications subject to change without notice.

Peavey Electronics Corporation • 711 A Street • Meridian • MS • 39301
(601) 483-5365 • FAX (601) 486-1278 • www.peavey.com

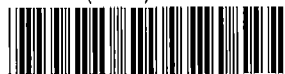

80301754