

Multiclip 46 Battery

8211-3417-05

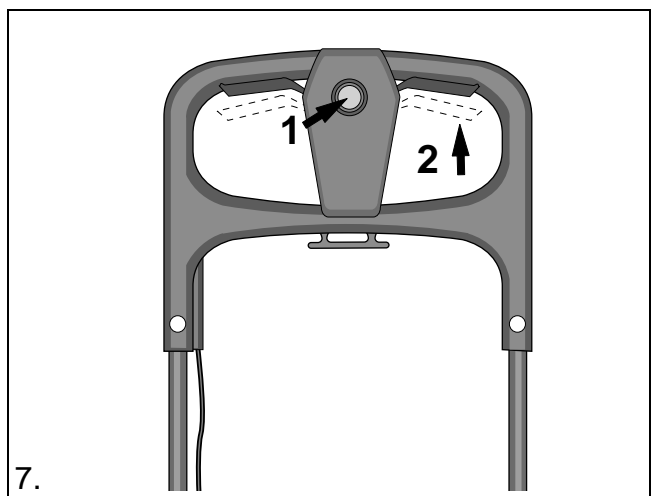

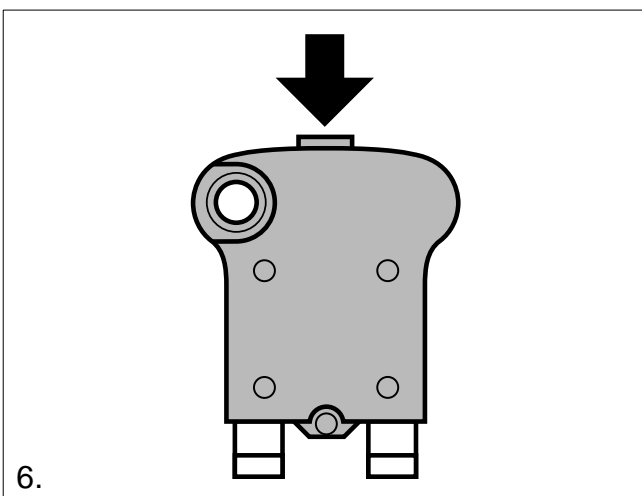
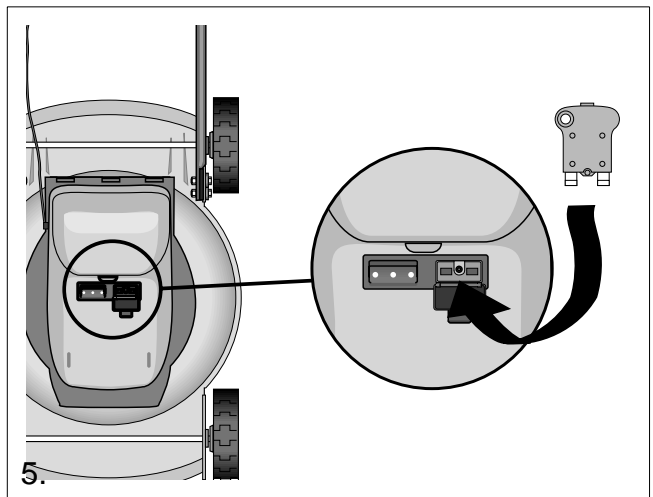
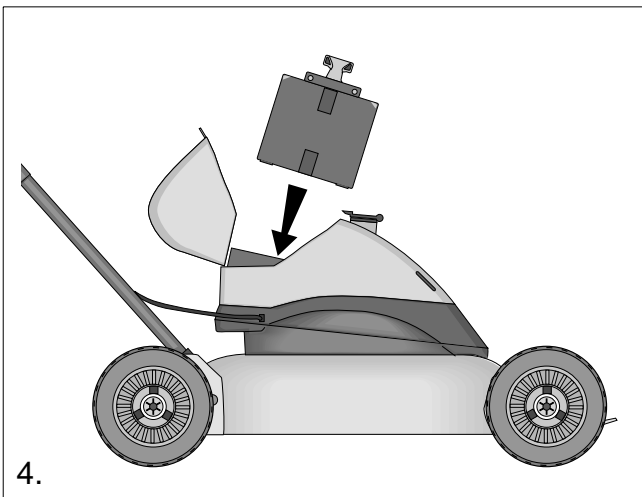
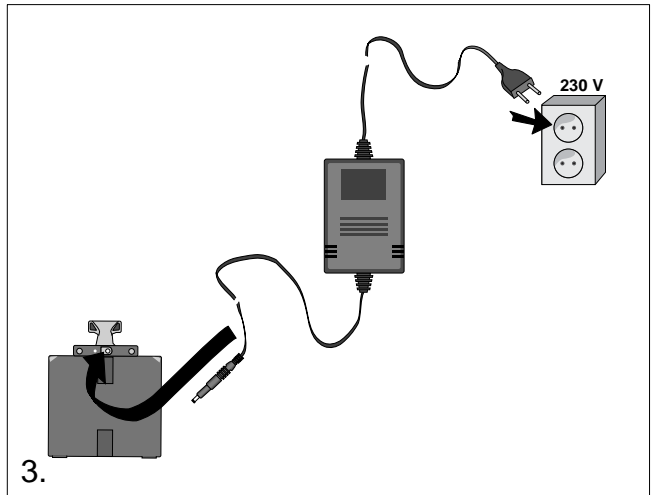
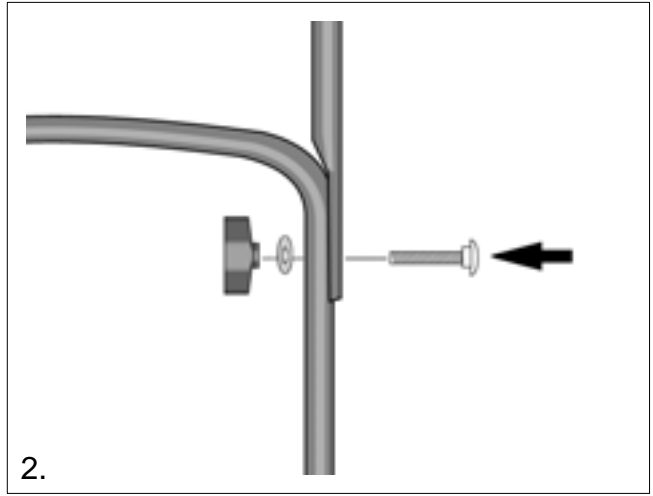
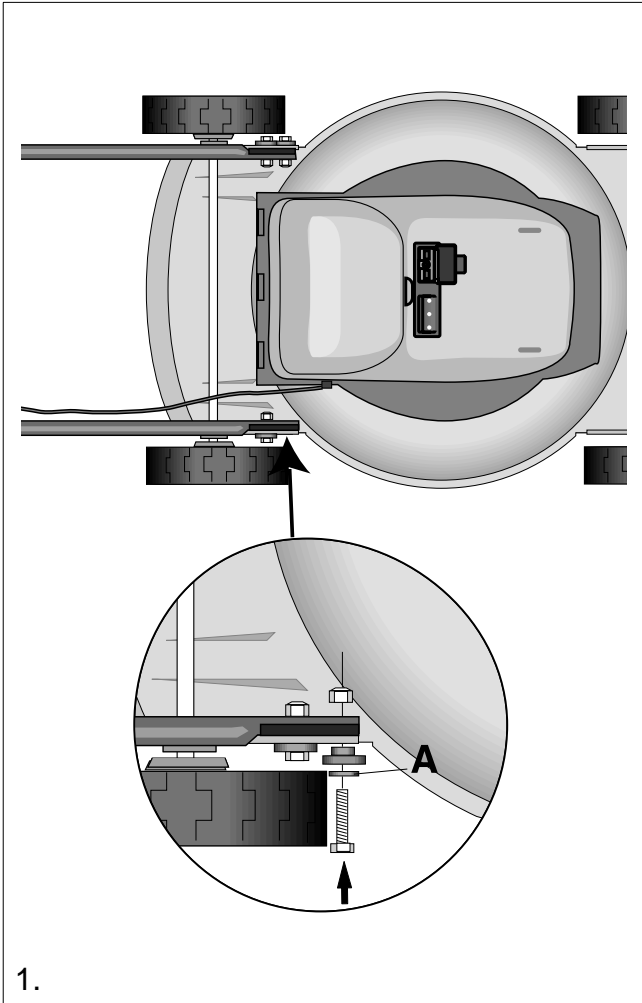
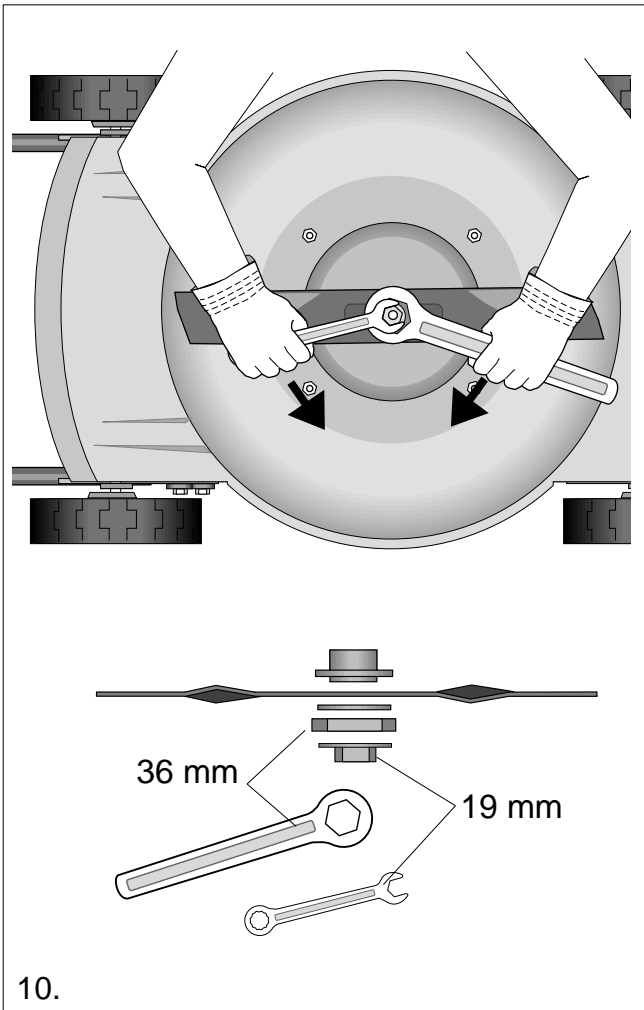
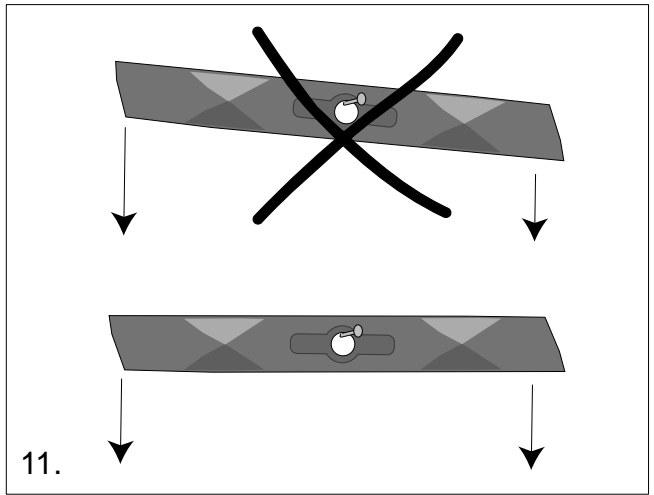
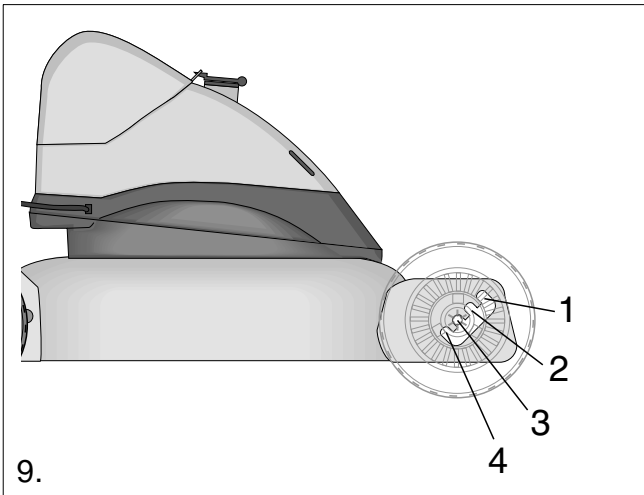
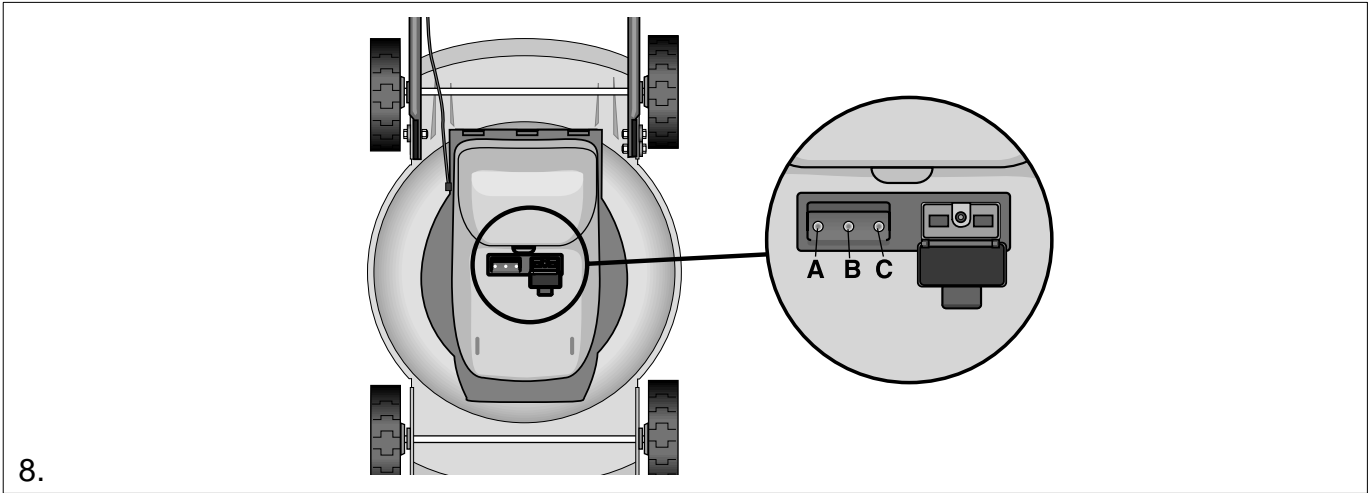

SYMBOLS

The following symbols are displayed on the machine in order to remind you about the safety precautions and attention necessary when using the machine.

The symbols mean:

	Warning! Read the Instruction Book and Safety Manual before using the machine.
	
	Warning! Keep spectators away. Beware of objects being flung out.
	
	Warning! Take out the safety key before any type of maintenance is carried out.
	
	Warning! Do not put hands or feet under the cover of the machine when it is running.
	
	Warning! The blades continue to rotate even after the machine has been switched off.
	
	When a red lamp lights up on the mower's control panel and/or a sound signal is activated, take out the safety key.
	
	

ASSEMBLY

When the machine was packed, it is possible that it was equipped with a lead for maintenance charging. When the mower is taken out of the packaging, this lead is no longer required and can be removed.

HANDLEBAR

1. Set the highest cutting height (position 4, see also under heading "cutting height")
2. The components for assembling the handle's lower part are mounted for packaging. Remove the components from the lower hole on the chassis. Then fold up the lower part of the han-

dle and assemble the components. Note! Washer A is fitted between the screw and the plastic bushing (fig. 1).

3. Mount the upper part of the handle onto the lower part with screws, washers and locking nuts (fig. 2).

BATTERY

GENERAL



Before starting the mower for the first time and after winter storage, you should charge the battery for 1 - 2 days otherwise the battery can be damaged.

In order for the battery to maintain its capacity and to give optimum performance, it is important that the charging and storage instructions are carefully followed.

- The battery used in this machine is a lead-acid type battery. This type of battery must always be stored fully charged.
- Always charge the battery indoors, in a garage, etc. where the battery is *dry and protected from the weather*.
- Only charge the battery when the temperature is at least 0°C and not over +40°C. Charging in lower or higher temperatures can damage the battery.
- Always keep the mower battery away from water, sources of heat (ovens, radiators, open fires, etc.) and hazardous chemicals.
- Always use the accompanying genuine Stiga charger. Never use the charger for any other product.
- Never use the charger if it is damaged in any way. A damaged lead or charger should immediately be replaced at an authorised service workshop
- Take care of the leads. Never carry the charger by the lead. When charging is complete pull out the plug not the lead. If an extension cable is used, use a robust sort suitable for outdoor use, even if the battery is never charged outdoors.
- The charger always feels warm to touch, during the first hours of charging.

CHARGING INSTRUCTIONS



The battery must always be charged directly after finishing mowing and as soon as it has cooled down (after about 30 minutes).

1. Charge the battery outside of the mower in a *dry and cool place*.
2. First connect the round plug from the charger to the battery (fig. 3).
3. Then connect the charger to a wall socket (~220/230V).
4. Charge for 1 - 2 days, depending on how long the machine has been used. Whilst the battery is charging, the red charging lamp on the battery is continuously lit, for as long as the battery charger is connected
5. Finish charging by firstly pulling out the plug from the wall socket.



If the charger is first removed from the battery, the plug leads can short-circuit if they come into contact with conductive material.

CHARGING BEFORE WINTER STORAGE



The battery should always be stored fully charged.

1. Take the battery out of the mower.
2. Carefully wipe off the battery.
3. Store the battery outside of the mower in a *dry and cool* place.

USING THE MOWER

STARTING/STOPPING THE MOWER



Keep hands and feet well away from the rotating blade(s). Never put your hand or foot under the blade casing or in the grass ejector unit while the motor is running.

1. Fix the battery in place in the mower (fig. 4).

2. Insert the safety key into the control panel (fig. 5). When the safety key is in place, the green lamp will be lit. If it is not, check that the engine protection on the safety key is pressed in (fig. 6) and that the battery is fully charged.
3. Press down the handle to lift the front wheels off the grass, thereby reducing grass resistance in the starting moment.
4. Press in the power on/off button **1** (fig. 7). Start the engine by pressing in the safety handle **2**. To stop, release the safety handle.

After finishing mowing:

1. **Remove the safety key and keep it out of reach of children.**
2. Clean the mower (see the "Maintenance" section under the heading "Cleaning").
3. Recharge the battery once it has cooled down (after about 30 minutes).



If the safety handle has stopped working, remove the safety key and take the mower to an authorised service workshop to be repaired.

CONTROL PANEL (fig. 8)

The control panel has the following functions:

1. It includes the socket for the safety key. The safety key also has an in-built engine protection. If the engine protection has been activated, remove the safety key and reset the engine protection (fig. 6).
2. It includes three lamps which indicate the battery's charge level:
 - A Green = the battery is charged to between 30% and 100% of full capacity.
 - B Yellow = the battery's power has reduced. Between 5% and 30% remains.
 - C Red = 5% or less of the battery power remains. The machine will begin to beep and will switch itself off automatically. Stop mowing and recharge the battery once it has cooled down (after about 30 minutes). Do not use the mower again until the battery is fully charged.

Important: do not allow the battery power to completely run down as this may damage the battery and shorten its operational life.

MOWING TIPS

For best cutting results and to ensure that the battery lasts as long as possible, the following rules should be followed:

- Drive the mower at a slow and even pace
- Try to avoid excessive starting and stopping, as this draws a lot of current.
- Make sure that the motor is running at full speed at all times when mowing.
- Mow regularly and often, especially when the grass is growing quickly. Do not mow more than a third of the total height of the grass during one mowing session.
- Always use a sharp blade.
- Do not use the mower when it is raining or when the grass is wet.
- Make sure that the underside of the cutting deck is kept clean.

CUTTING HEIGHT



Do not set the cutting height so low that the blade/ blades can hit uneven ground.

When adjusting the cutting height, firstly pull out the safety key.

The cutting height can be adjusted to four positions by moving the wheel axles (fig. 9).

Position 1 = Lowest cutting height

Position 4 = Highest cutting height

MAINTENANCE



Take out the safety key and remove the battery before any type of maintenance is carried out.

CLEANING

The mower should be cleaned after each use. Use a damp rag or sponge with a mild soap solution. Do not use water or detergents for cleaning. Remove all grass clippings which have gathered under the cover.

CHANGING THE BLADE



Check, before and after each use, that the blade is tightly fixed and that it is not damaged. A bent or damaged blade should immediately be replaced. Use protective gloves to avoid cutting injuries.

Blunt and/or damaged blades tear off the grass and make the lawn look ugly after mowing. New, well-sharpened blades cut off the grass and ensure that it looks green and fresh after it has been mown.

Remove the battery. Put the accompanying wrench (36 mm) on the hexagon holder. Loosen the blade nut with an adjustable wrench or another type of fixed wrench (19 mm) (fig. 10). Turn the blade nut in an anti-clockwise direction in order to remove the blade.

Fit the new blade and refit all the other parts exactly as they were before they were dismantled, see fig. 10. Tighten the blade nut fully.

SHARPENING THE BLADE

Water grinding with whetstone or a grinding stone should be used to sharpen the blade.

For safety reasons, the blade should not be sharpened on an emery wheel. Too high a temperature can result in the blade becoming brittle.



If the blade is sharpened, it must be balanced afterwards to avoid vibration damage (fig. 11).

Problem	Possible causes
1. Mower does not start when safety key is inserted and the safety handle is pressed in	A. Check to make sure the safety key has been properly inserted and that the engine protection is pressed in. B. Remove safety key, turn mower over on side and check that blade is not obstructed. C. Is battery fully charged? Plug in charger and check lamps.
2. Mower stops while mowing (for reason other than releasing the safety handle).	A. The engine protection in the safety key has cut off power to protect engine. Wait a couple of seconds for it to cool and then press in the engine protection. B. Remove safety key. Turn mower over and check that blade is free to turn. Also check deck and ejector for clogging. C. Mower is trying to cut too much grass. Raise it to higher cutting height and try to start again. D. Check to see if battery needs to be recharged.
3. Mower vibrates excessively or makes excessive noise.	A. Remove safety key. Turn mower over to check if blade is properly tightened. B. Remove safety key. Turn mower over to check if blade has been bent, damaged or worn out. Replace with an original blade. C. Remove safety key. Turn mower over to check mower deck for damage. If damaged, contact an authorised service dealer. D. If no visible damage to mower or blade, return mower to an authorised service dealer.
4. Mower runs but cutting performance is unsatisfactory and/or there is a loss of power while mowing.	A. Was battery fully charged at the start? B. Remove safety key. Turn mower over to check if: -blade is correctly attached. -blade is sharp. -blade is bent, loose or damaged. -deck and/or ejector and/or grass collector are clogged C. Cutting height may be set too low, causing heavy strain on motor by trying to cut too much grass. Raise to a higher cutting position.
5. Mower is hard to push.	A. Mower is trying to cut too much grass (See problem 4, Cause C.) B. Remove safety key. Turn mower over to check if all wheels rotate freely and check them for damage. Obtain original replacement wheels from an authorised service dealer.
6. Mower engine will not stop when the safety handle is released.	A. Remove safety key to shut off motor. Mower can not then be started. Contact an authorised service dealer.
7. Mower cannot finish cutting the lawn on a single charge any more.	A. Was battery fully charged at the start? B. Mower is trying to cut too much grass (See problem 4, Cause C.) C. Contact an authorised service dealer for battery check.
8. Red lamp on charger does not come on when charger is plugged into wall outlet.	A. Wall outlet does not have power. (Verify with another electric device.) B. The charger fuse may need to be replaced. Contact an authorised service dealer C. Charger or cord may be defective. Contact an authorised service dealer.

If the mower still doesn't work, despite measures taken according to this table, contact an authorised service dealer.