

# Safety Instructions & Operator's Manual for

# SNAPPER®

## FastCut HYDRO DRIVE ZTR

## SERIES 1

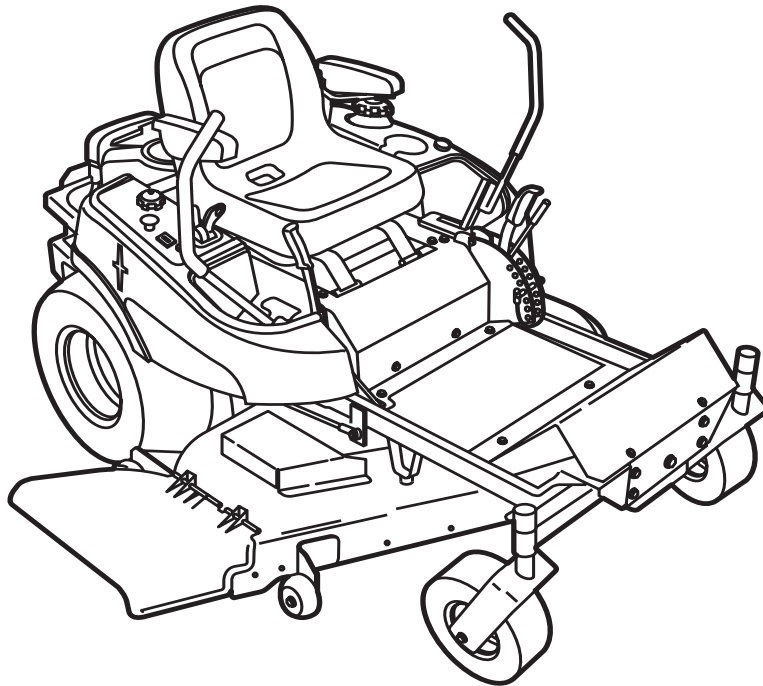

<b>MODEL</b>
ZT18441KHC
ZT19441KWV
ZT20501BV

MODEL NUMBER EXPLANATION						
Z	T	20	50	1	B	V
DRIVE SYSTEM TYPE	MOWER ORIENTATION	ENGINE HP *	MOWER DECK SIZE	POWER UNIT		ENGINE TYPE
						ENGINE BRAND
						SERIES DESIGNATION
Z - Zero Turning - Hydro Drive	T - Twin Stick Control	20 - Engine Horse Power	50 - 50" Mower Width	1 - Series Designation	B - Briggs & Stratton Engine	C - Dual Cam OHV
18 - Engine Horse Power	19 - Engine Horse Power					V - Overhead Valve

**Thank you for buying a SNAPPER Product! Before operating your machine, read this manual carefully and pay particular attention to the "IMPORTANT SAFETY INSTRUCTIONS" on pages 2 - 4. Remember that all power equipment can be dangerous if used improperly. Also keep in mind that SAFETY requires careful use in accordance with the operating instructions and common sense!**

NOTE: Specifications are correct at the time of printing and are subject to change without notice.

\* Actual sustained equipment horsepower will likely be lower due to operating limitation and environmental factors.

**SNAPPER®** McDonough, GA 30253 USA

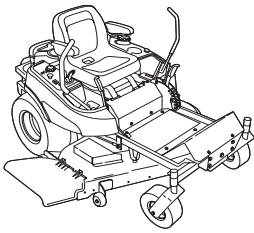

# Table of Contents

<b>Safety Rules &amp; Information</b> .....	<b>2</b>	<b>Troubleshooting, Adjustments &amp; Service</b> .....	<b>19</b>
<b>Safety Decals</b> .....	<b>5</b>	Troubleshooting the Rider .....	19
<b>Features &amp; Controls</b> .....	<b>6</b>	Troubleshooting the Mower .....	20
Control Functions .....	6	Seat Adjustments .....	21
<b>Operation</b> .....	<b>8</b>	Ground Speed Control Lever Adjustment .....	21
General Operating Safety .....	8	Speed Balancing Adjustment .....	21
Checks Before Starting .....	8	Cutting Height Adjustment .....	22
Starting the Engine .....	9	Parking Brake Adjustment.....	22
Stopping the Rider & Engine.....	9	Neutral Adjustments.....	22
Mowing.....	9	PTO Clutch Adjustment.....	23
Pushing the Rider by Hand .....	9	Blade Brake Check .....	23
Zero Turn Driving Practice.....	10	Mower Deck Leveling .....	24
Attaching a Trailer.....	12	Hydraulic Pump Drive Belt Replacement.....	25
Mower Removal & Installation.....	13	Battery Charging .....	25
<b>Regular Maintenance</b> .....	<b>14</b>	Mower Belt Replacement .....	26
Schedule .....	14		
Lubrication .....	15		
Servicing the Mower Blades .....	16		
Checking Tire Pressures .....	17		
Checking/Adding Fuel.....	17		
Fuel Filter .....	17		
Engine Maintenance .....	17		
Check/Fill Transmission Oil .....	17		
Transmission Oil Filter Change .....	18		
Battery Maintenance .....	18		
Storage.....	18		

*NOTE: In this manual, “left” and “right” are referred to as seen from the operating position.*

## **WARNING**

You must read, understand and comply with all safety and operating instructions in this manual before attempting to set-up and operate your machine.

Failure to comply with all safety and operating instructions can result in loss of machine control, serious personal injury to you and / or bystanders, and risk of equipment and property damage. The triangle in the text signifies important cautions or warnings which must be followed.

## **WARNING**

**Engine exhaust from this product contains chemicals known, in certain quantities, to cause cancer, birth defects, or other reproductive harm.**

# Safety Rules and Information



Read these safety rules and follow them closely. Failure to obey these rules could result in loss of control of unit, severe personal injury or death to you, or bystanders, or damage to property or equipment.

**This mowing deck is capable of amputating hands and feet and throwing objects.**

The triangle  in text signifies important cautions or warnings which must be followed.

## GENERAL OPERATION

1. Read, understand, and follow all instructions in the manual and on the unit before starting.
2. Do not put hands or feet near rotating parts or under the machine. Keep clear of the discharge opening at all times.
3. Only allow responsible adults, who are familiar with the instructions, to operate the unit (local regulations can restrict operator age).
4. Clear the area of objects such as rocks, toys, wire, etc., which could be picked up and thrown by the blade(s).
5. Be sure the area is clear of other people before mowing. Stop the unit if anyone enters the area.
6. Never carry passengers.
7. Do not mow in reverse unless absolutely necessary. Always look down and behind before and while traveling in reverse.
8. Never direct discharge material toward anyone. Avoid discharging material against a wall or obstruction. Material may ricochet back toward the operator. Stop the blade(s) when crossing gravel surfaces.
9. Do not operate the machine without the entire grass catcher, discharge guard (deflector), or other safety devices in place and operational.
10. Slow down before turning.
11. Never leave a running unit unattended. Always disengage the blades (PTO), set parking brake, stop engine, and remove keys before dismounting.
12. Disengage blades (PTO) when not mowing. Shut off engine and wait for all parts to come to a complete stop before cleaning the machine, removing the grass catcher, or unclogging the discharge guard.
13. Operate the machine only in daylight or good artificial light.
14. Do not operate the unit while under the influence of alcohol or drugs.
15. Watch for traffic when operating near or crossing roadways.
16. Use extra care when loading or unloading the unit into a trailer or truck.
17. Always wear eye protection when operating this unit.
18. Data indicates that operators, age 60 years and above, are involved in a large percentage of power equipment-related injuries. These operators should evaluate their ability to operate the equipment safely enough to protect themselves and others from injury.
19. Follow the manufacturer's recommendations for wheel weights or counterweights.
20. Keep in mind the operator is responsible for accidents occurring to other people or property.
21. All drivers should seek and obtain professional and practical instruction.
22. Always wear substantial footwear and trousers. Never operate when barefoot or wearing sandals.
23. Before using, always visually check that the blades and blade hardware are present, intact, and secure. Replace worn or damaged parts.
24. Disengage attachments before: refueling, removing an attachment, making adjustments (unless the adjustment can be made from the operator's position).
25. When the machine is parked, stored, or left unattended, lower the cutting means unless a positive mechanical lock is used.
26. Before leaving the operator's position for any reason, engage the parking brake (if equipped), disengage the blades (PTO), stop the engine, and remove the key.
27. To reduce fire hazard, keep the unit free of grass, leaves, & excess oil. Do not stop or park over dry leaves, grass, or combustible materials.
28. It is a violation of California Public Resource Code Section 4442 to use or operate the engine on or near any forest-covered, brush-covered, or grass-covered land unless the exhaust system is equipped with a spark arrester meeting any applicable local or state laws. Other states or federal areas may have similar laws.
29. OSHA regulations may require the use of hearing protection when exposed to sound levels greater than 85 dBA for an 8 hour time period.

## CAUTION



This machine produces sound levels in excess of 85 dBA at the operator's ear and can cause hearing loss through extended periods of exposure.

Wear hearing protection when operating this machine.

## TRANSPORTING AND STORAGE

1. When transporting the unit on an open trailer, make sure it is facing forward, in the direction of travel. If the unit is facing backwards, wind lift could damage the unit.
2. Always observe safe refueling and fuel handling practices when refueling the unit after transportation or storage.
3. Never store the unit (with fuel) in an enclosed poorly ventilated structure. Fuel vapors can travel to an ignition source (such as a furnace, water heater, etc.) and cause an explosion. Fuel vapor is also toxic to humans and animals.
4. Always follow the engine manual instructions for storage preparations before storing the unit for both short and long term periods.
5. Always follow the engine manual instructions for proper start-up procedures when returning the unit to service.
6. Never store the unit or fuel container inside where there is an open flame or pilot light, such as in a water heater. Allow unit to cool before storing.

## SLOPE OPERATION

Slopes are a major factor related to loss-of-control and tip-over accidents, which can result in severe injury or death. Operation on all slopes requires extra caution. If you cannot back up the slope or if you feel uneasy on it, do not operate on it.

Control of a walk-behind or ride-on machine sliding on a slope will not be regained by the application of the brake. The main reasons for loss of control are: insufficient tire grip on the ground, speed too fast, inadequate braking, the type of machine is unsuitable for its task, lack of awareness of the ground conditions, incorrect hitching and load distribution.

1. Mow across slopes, not up and down.
2. Watch for holes, ruts, or bumps. Uneven terrain could overturn the unit. Tall grass can hide obstacles.
3. Choose a slow speed so that you will not have to stop or change speeds while on the slope.
4. Do not mow on wet grass. Tires may lose traction.
5. Never mow down slopes.
6. Avoid starting, stopping, or turning on a slope. If tires lose traction (i.e. machine stops forward motion on a slope), disengage the blade(s) (PTO) and drive slow off the slope.
7. Keep all movement on slopes slow and gradual. Do not make sudden changes in speed or direction, which could cause the machine to rollover.
8. Use extra care while operating machines with grass catchers or other attachments; they can affect the stability of the unit. Do not use on steep slopes.
9. Do not try to stabilize the machine by putting your foot on the ground (ride-on units).
10. Do not mow near drop-offs, ditches, or embankments. The mower could suddenly turn over if a wheel is over the edge of a cliff or ditch, or if an edge caves in.
11. Do not use grass catchers on steep slopes.
12. Do not mow slopes if you cannot back up them.
13. See your authorized dealer/retailer for recommendations of wheel weights or counterweights to improve stability.
14. Remove obstacles such as rocks, tree limbs, etc.
15. Use slow speed. Tires may lose traction on slopes even through the brakes are functioning properly.
16. Do not turn on slopes unless necessary, and then, turn slowly and gradually uphill, if possible. Never mow down slopes.

## TOWED EQUIPMENT (RIDE-ON UNITS)

1. Tow only with a machine that has a hitch designed for towing. Do not attach towed equipment except at the hitch point.
2. Follow the manufacturer's recommendations for weight limit for towed equipment and towing on slopes. See attaching a trailer under OPERATION.
3. Never allow children or others in or on towed equipment.
4. On slopes, the weight of the towed equipment may cause loss of traction and loss of control.
5. Travel slowly and allow extra distance to stop.
6. Do not shift to neutral and coast down hill.

## WARNING

Never operate on slopes greater than 17.6 percent (10°) which is a rise of 3-1/2 feet (106 cm) vertically in 20 feet (607 cm) horizontally.

Select slow ground speed before driving onto slope. Use extra caution when operating on slopes with rear-mounted grass catchers.

Mow across the face of slopes, not up and down, use caution when changing directions and **DO NOT START OR STOP ON SLOPE.**

## CHILDREN

Tragic accidents can occur if the operator is not alert to the presence of children. Children are often attracted to the unit and the mowing activity. Never assume that children will remain where you last saw them.

1. Keep children out of the mowing area and under the watchful care of another responsible adult.
2. Be alert and turn unit off if children enter the area.
3. Before and during reverse operation, look behind and down for small children.
4. Never carry children, even with the blade(s) off. They may fall off and be seriously injured or interfere with safe unit operation. Children who have been given rides in the past may suddenly appear in the mowing area for another ride and be run over or backed over by the machine.
5. Never allow children to operate the unit.
6. Use extra care when approaching blind corners, shrubs, trees, or other objects that may obscure vision.

## EMISSIONS

1. Engine exhaust from this product contains chemicals known, in certain quantities, to cause cancer, birth defects, or other reproductive harm.
2. Look for the relevant Emissions Durability Period and Air Index information on the engine emissions label.

## IGNITION SYSTEM

1. This spark ignition system complies with Canadian ICES-002.

# Safety Rules and Information

---

## SERVICE AND MAINTENANCE

### Safe Handling of Gasoline

1. Extinguish all cigarettes, cigars, pipes, and other sources of ignition.
2. Use only approved gasoline containers.
3. Never remove the gas cap or add fuel with the engine running. Allow the engine to cool before refueling.
4. Never fuel the machine indoors.
5. Never store the machine or fuel container where there is an open flame, spark, or pilot light such as near a water heater or other appliance.
6. Never fill containers inside a vehicle or on a truck bed with a plastic bed liner. Always place containers on the ground away from your vehicle before filling.
7. Remove gas-powered equipment from the truck or trailer and refuel it on the ground. If this is not possible, then refuel such equipment on a trailer with a portable container, rather than from a gasoline dispenser nozzle.
8. Keep nozzle in contact with the rim of the fuel tank or container opening at all times until fueling is complete. Do not use a nozzle lock-open device.
9. If fuel is spilled on clothing, change clothing immediately.
10. Never over-fill the fuel tank. Replace gas cap and tighten securely.
11. Use extra care in handling gasoline and other fuels. They are flammable and vapors are explosive.
12. If fuel is spilled, do not attempt to start the engine but move the machine away from the area of spillage and avoid creating any source of ignition until fuel vapors have dissipated.
13. Replace all fuel tank caps and fuel container caps securely.
13. If the fuel tank must be drained, it should be drained outdoors.
14. Replace faulty silencers/mufflers.
15. Maintain or replace safety and instruction labels as necessary.
16. Use only factory authorized replacement parts when making repairs.
17. Always comply with factory specifications on all settings and adjustments.
18. Only authorized service locations should be utilized for major service and repair requirements.
19. Never attempt to make major repairs on this unit unless you have been properly trained. Improper service procedures can result in hazardous operation, equipment damage and voiding of manufacturer's warranty.
20. On multiple blade mowers, take care as rotating one blade can cause other blades to rotate.
21. Do not change engine governor settings or over-speed the engine. Operating the engine at excessive speed can increase the hazard of personal injury.
22. Disengage drive attachments, stop the engine, remove the key, and disconnect the spark plug wire(s) before: clearing attachment blockages and chutes, performing service work, striking an object, or if the unit vibrates abnormally. After striking an object, inspect the machine for damage and make repairs before restarting and operating the equipment.
23. Never place hands near the moving parts, such as a hydro pump cooling fan, when the tractor is running. (Hydro pump cooling fans are typically located on top of the transaxle).
24. Units with hydraulic pumps, hoses, or motors: **WARNING:** Hydraulic fluid escaping under pressure may have sufficient force to penetrate skin and cause serious injury. If foreign fluid is injected into the skin it must be surgically removed within a few hours by a doctor familiar with this form of injury or gangrene may result. Keep body and hands away from pin holes or nozzles that eject hydraulic fluid under high pressure. Use paper or cardboard, and not hands, to search for leaks. Make sure all hydraulic fluid connections are tight and all hydraulic hoses and lines are in good condition before applying pressure to the system. If leaks occur, have the unit serviced immediately by your authorized dealer.

### Service & Maintenance

1. Never run the unit in an enclosed area where carbon monoxide fumes may collect.
2. Keep nuts and bolts, especially blade attachment bolts, tight and keep equipment in good condition.
3. Never tamper with safety devices. Check their proper operation regularly and make necessary repairs if they are not functioning properly.
4. Keep unit free of grass, leaves, or other debris build-up. Clean up oil or fuel spillage, and remove any fuel-soaked debris. Allow machine to cool before storage.
5. If you strike an object, stop and inspect the machine. Repair, if necessary, before restarting.
6. Never make adjustments or repairs with the engine running.
7. Check grass catcher components and the discharge guard frequently and replace with manufacturer's recommended parts, when necessary.
8. Mower blades are sharp. Wrap the blade or wear gloves, and use extra caution when servicing them.
9. Check brake operation frequently. Adjust and service as required.
10. Maintain or replace safety and instructions labels, as necessary.
11. Do not remove the fuel filter when the engine is hot as spilled gasoline may ignite. Do not spread fuel line clamps further than necessary. Ensure clamps grip hoses firmly over the filter after installation.
12. Do not use gasoline containing METHANOL, gasohol containing more than 10% ETHANOL, gasoline additives, or white gas because engine/fuel system damage could result.
25. **WARNING:** Stored energy device. Improper release of springs can result in serious personal injury. Springs should be removed by an authorized technician.
26. Models equipped with an engine radiator: **WARNING:** Stored energy device. To prevent serious bodily injury from hot coolant or steam blow-out, never attempt to remove the radiator cap while the engine is running. Stop the engine and wait until it is cool. Even then, use extreme care when removing the cap.

## SAFETY DECALS

This unit has been designed and manufactured to provide you with the safety and reliability you would expect from an industry leader in outdoor power equipment manufacturing.

Although reading this manual and the safety instructions it contains will provide you with the necessary basic knowledge to operate this equipment safely and effectively, we have placed several safety labels on the unit to remind you of this important information while you are operating your unit.

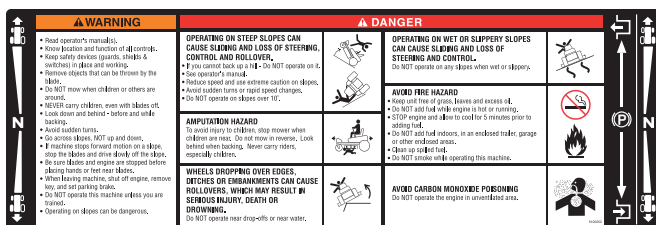

**Decal - Main**  
Part No. 5100252



**Decal - Danger, Mower Discharge**  
Part No. 5100137

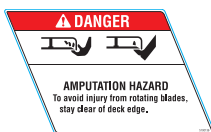

**Decal - Danger, Mower**  
Part No. 5100136



**Decal - Throttle Control**  
Part No. 5100280



**Decal - Ignition Switch**  
Part No. 5048970

All DANGER, WARNING, CAUTION and instructional messages on your rider and mower should be carefully read and obeyed. Personal bodily injury can result when these instructions are not followed. The information is for your safety and it is important! The safety decals below are on your rider and mower.

If any of these decals are lost or damaged, replace them at once. See your local dealer for replacements.

These labels are easily applied and will act as a constant visual reminder to you, and others who may use the equipment, to follow the safety instructions necessary for safe, effective operation.

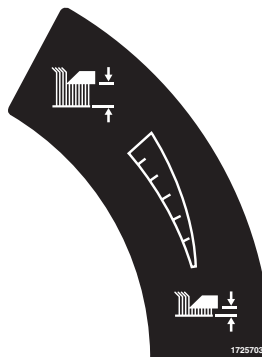

**Decal - Cut Height**  
Part No. 1725703

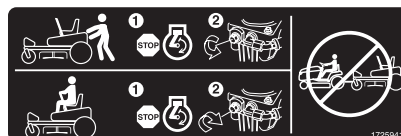

**Decal - CZT Hydro Release**  
Part No. 1725941

Belts & Blades	
<b>Tractor</b>	
Pump Drive Belt	5022931
<b>44" Mower</b>	
Deck Drive Belt	5023256
Mower Blade	1704100
<b>50" Mower</b>	
Deck Drive Belt	5023255
Mower Blade	1708229

**Decal - Belt & Blade**  
Part No. 5048907



# Features & Controls

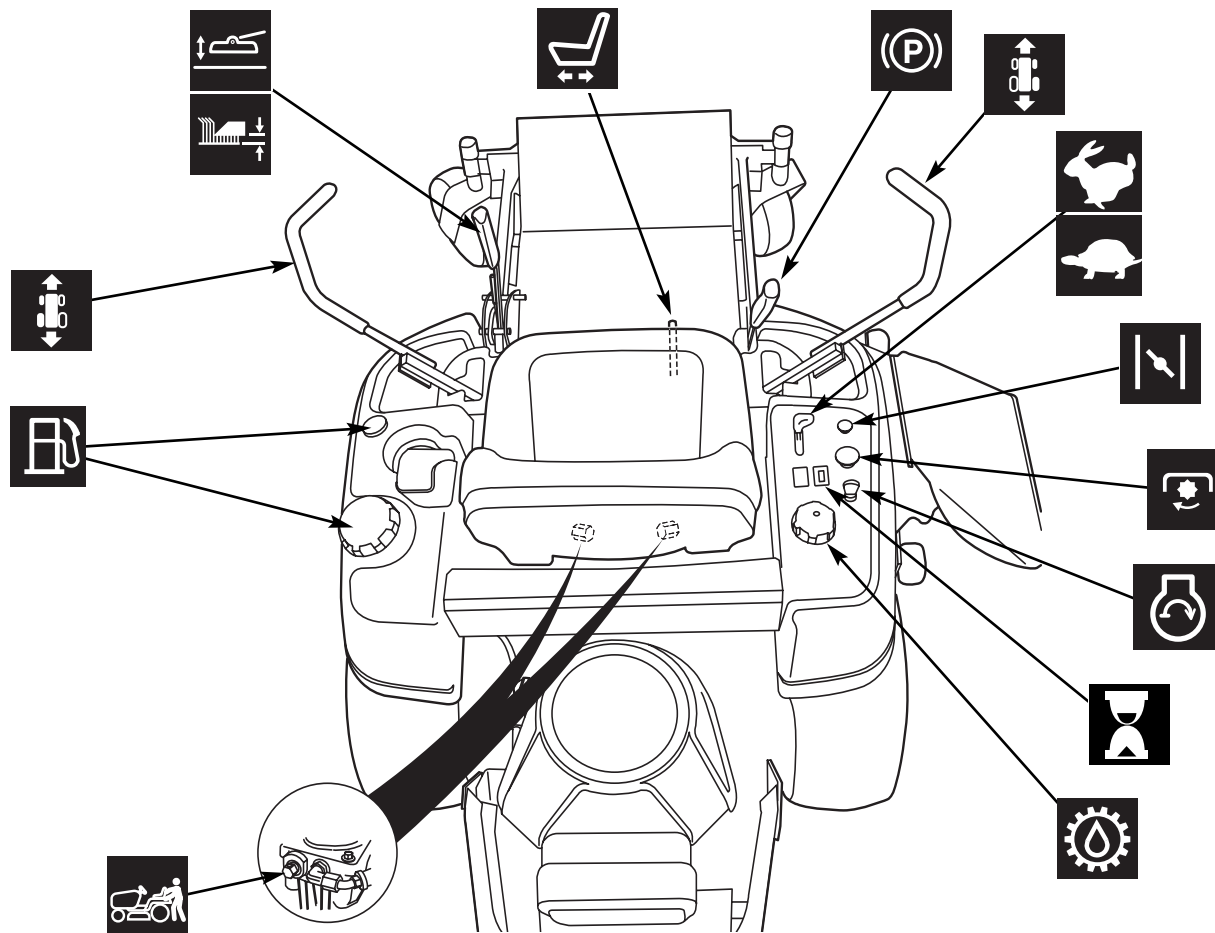
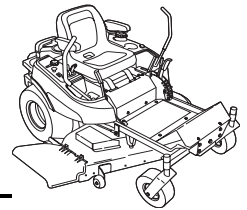

## CONTROL FUNCTIONS

The information below briefly describes the function of individual controls. Starting, stopping, driving, and mowing require the combined use of several controls applied in specific sequences. To learn what combination and sequence of controls to use for various tasks see the OPERATION section.

### Ground Speed Levers

These levers control the ground speed of the rider. The left lever controls the left rear drive wheel and the right controls the right rear drive wheel.

Moving a lever forward increases the FORWARD speed of the associated wheel, and pulling back on a lever increases the REVERSE speed.

The further a lever is moved away from the neutral position the faster the drive wheel will turn.

See the OPERATION section for steering instructions.

### Throttle Control

The throttle controls engine speed. Move the throttle forward to increase engine speed and back to decrease engine speed. Always operate at FULL throttle.

### Choke

Close the choke for cold starting. Open the choke once the engine starts. A warm engine may not require choking. Move the lever forward to close the choke. Move the lever back to open the choke.



## Ignition Switch

The ignition switch starts and stops the engine; it has three positions:



**OFF** Stops the engine and shuts off the electrical system.



**RUN** Allows the engine to run and powers the electrical system.



**START** Cranks the engine for starting.

*NOTE: Never leave the ignition switch in the RUN position with the engine stopped—this drains the battery.*



## Hour Meter / Maintenance Reminder

The hour meter measures the number of hours the key has been in the RUN position. The hour meter will flash an initial oil change indicator at 5 hours, and a lubrication reminder every 50 hours. These reminders display for approximately two hours and will automatically reset themselves.

*Note: The hour meter will register the passage of time when the key is in the RUN position, even if the engine is not running. The hour meter has a self contained power source so the total hours are always visible.*



## PTO Switch

The PTO (Power Take-Off) switch engages and disengages attachments that use the PTO. To engage the PTO, pull UP on the switch. Push DOWN to disengage. Note that the operator must be seated firmly in the rider seat for the PTO to function.



## Transmission Oil Fill

Transmission oil is added through the transmission oil expansion chamber. It also serves as extra holding capacity for oil as the transmission heats up and the oil expands. See CHECK TRANSMISSION OIL LEVEL for oil level check and fill procedures.



## Transmission Release Valves

The transmission release valves deactivate the transmissions so that the unit can be pushed by hand. See PUSHING THE UNIT BY HAND for operational information.



## Seat Adjustment Lever

The seat can be adjusted forward and backward. Move the adjustment lever towards the left, slide the seat to the desired position, and release the lever.



## Fuel Tank & Gauge

To remove the cap, turn counterclockwise. The fuel gauge is mounted in the fuel tank and indicates the amount of fuel in the tank.



## Mower Height of Cut Adjustment &



## Attachment Lift Control Lever

To adjust cutting height, pull the large lever back fully to lock the control in the attachment raised transport position. Position the cutting height selector pin on the appropriate hole to achieve the desired cutting height. Pull back on the small lift latch lever and large lever simultaneously, and lower the mower into cutting position.

For attachment transport lift, pull the large lift lever back fully to lock the control in the attachment raised transport position.



## Parking Brake



**DISENGAGE** Releases the parking brake.



**ENGAGE** Locks the parking brake.

Pull the parking brake lever back to engage the parking brake. Move the lever fully forward to disengage the parking brake. *NOTE: To start the unit the parking brake must be engaged.*



# Operation

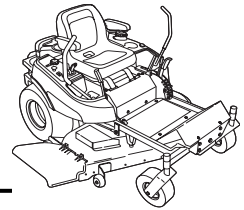

## GENERAL OPERATING SAFETY

Before first time operation:

- Be sure to read all information in the Safety and Operation sections before attempting to operate this tractor and mower.
- Become familiar with all of the controls and how to stop the unit.
- Drive in an open area without mowing to become accustomed to the unit. brake pedal or set the parking brake.

### **!** WARNING

Never operate on slopes greater than 17.6 percent (10°) which is a rise of 3-1/2 feet (106 cm) vertically in 20 feet (607 cm) horizontally.

Select slow ground speed before driving onto a slope. Use extra caution when operating on slopes with a rear-mounted grass catcher.

Mow across the face of slopes, not up and down, use caution when changing directions and **DO NOT START OR STOP ON SLOPE.**

### **!** WARNING

Never allow passengers to ride on the unit. Before leaving the operator's position for any reason, engage the parking brake, disengage the PTO, stop the engine and remove the key. To reduce fire hazard, keep the engine, tractor and mower free of grass, leaves and excess grease. Do not stop or park tractor over dry leaves, grass or combustible materials. Gasoline is highly flammable and must be handled with care. Never fill the tank when the engine is still hot from recent operation. Do not allow open flame, smoking or matches in the area. Avoid over-filling and wipe up any spills.

## CHECKS BEFORE STARTING

- Check that crankcase is filled to full mark on dipstick. See the engine Operator's Manual for instructions and oil recommendations.
- Make sure all nuts, bolts, screws and pins are in place and tight.
- Adjust the seat position, and make certain you can reach all controls from operator's position.
- Fill the fuel tank with fresh fuel. Refer to engine manual for fuel recommendations.

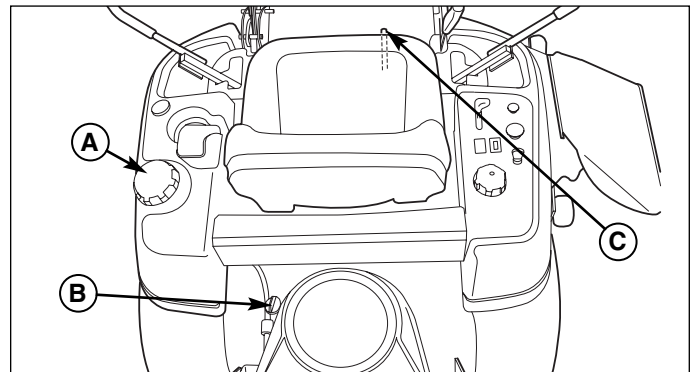
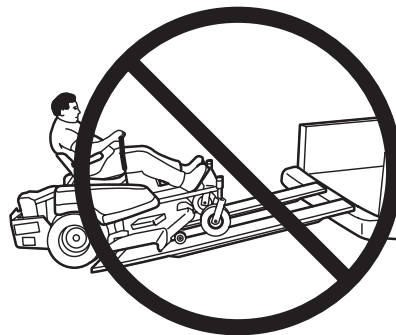

Figure 1. Pre-Start Checks

- A. Fuel Tank Cap
- B. Crankcase Oil Fill
- C. Seat Adjustment Lever

### **!** WARNING

Do not load this zero-turn rider on a trailer or truck using two separate ramps. Only use a single ramp that is at least one foot wider than the width of the rear wheels of this rider. This rider has a zero turning radius and the rear wheels could fall off the ramps, or the rider could tip over injuring the operator or bystanders.



## WARNING

If you do not understand how a specific control functions, or have not yet thoroughly read the **FEATURES & CONTROLS** section, do so now. Do NOT attempt to operate the tractor without first becoming familiar with the location and function of ALL controls.

## STARTING THE ENGINE

1. While sitting in the operator's seat, engage the parking brake and make sure the PTO switch is disengaged and the motion control handles are locked in the NEUTRAL position.
2. **NOTE: A warm engine may not require choking.**  
Set the engine throttle control to FAST throttle position. Then fully close the choke by pulling the knob OUT fully.
3. Insert the key into the ignition switch and turn it to START.
4. After the engine starts, gradually open the choke (push knob down fully).

*Warm up the engine by running it for at least a minute before engaging the PTO switch or driving the rider.*

5. **After warming the engine, ALWAYS operate the unit at FULL THROTTLE when mowing.**

**In the event of an emergency the engine can be stopped by simply turning the ignition switch to STOP.** Use this method only in emergency situations. For normal engine shut down follow the procedure given in STOPPING THE RIDER.

## STOPPING THE RIDER

1. Returning the ground speed control levers to the middle position will stop tractor movement. Pivot the levers outward and lock them in NEUTRAL.
2. Disengage the PTO by pushing down on the PTO switch.
3. Engage the parking brake by pulling the handle up until it locks into position.
4. Move the throttle control to mid-throttle position and turn the ignition key to OFF. Remove the key.

## MOWING

1. Engage the parking brake. Make sure the PTO switch is disengaged, the motion control handles are locked in the NEUTRAL position and the operator is on the seat.
2. Start the engine (see STARTING THE ENGINE).
3. Set the mower cutting height.
4. Set the throttle to FULL.
5. Engage the PTO by pulling up on the PTO switch.
6. Begin mowing. See Section LC for tips on mowing patterns, lawn care, and trouble shooting information.
7. When finished, shut off the PTO.
8. Stop the engine (see STOPPING THE TRACTOR AND ENGINE).

## PUSHING THE RIDER BY HAND



### DO NOT TOW RIDER

Towing the unit will cause hydraulic pump and wheel motor damage. Do not use another vehicle to push or pull this unit.

1. Disengage the PTO, engage the parking brake, turn the ignition OFF, and remove the key.
2. Lift the seat plate to gain access to the hydraulic pumps.
3. To disengage the pumps (free-wheel position), turn the hydraulic release valves (A, Figure 2) located on the pumps COUNTER-CLOCKWISE a maximum of 2 full turns.
4. Disengage the parking brake.  
The tractor can now be pushed by hand.
5. After moving the tractor, re-engage the pumps (drive position) by turning the release valves CLOCKWISE and tighten to 80-120 in. lbs. of torque.

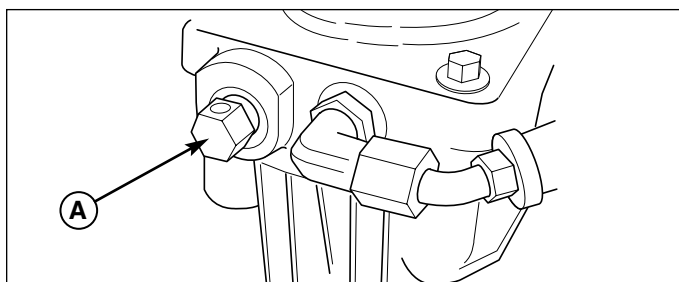

**Figure 2. Transmission Release Valves**  
**A. Hydraulic Release Valve (On Each Pump)**

# Operation

## ZERO TURN DRIVING PRACTICE

The lever controls of the zero turn rider are responsive, and learning to gain a smooth and efficient control of the rider's forward, reverse, and turning movements will take some practice.

Spending some time going through the maneuvers shown and becoming familiar with how the unit accelerates, travels, and steers — before you begin mowing — is absolutely essential to getting the most out of the zero turn rider.

**Locate a smooth, flat area of your lawn** — one with plenty of room to maneuver. (Clear the area of objects, people and animals before you begin.) Operate the unit at mid-throttle during this practice session (ALWAYS operate at full throttle when mowing), and turn slowly to prevent tire slippage and damage to your lawn.

We suggest you begin with the Smooth Travel procedure to the right, and then advance through the forward, reverse, and turning maneuvers.

You must release the parking brake prior to moving the control levers inward.

## BASIC DRIVING

### Forward Travel Practice

Gradually move both ground speed control levers — evenly FORWARD from neutral. Slow down and repeat.

*NOTE: Straight forward travel takes practice. If necessary, top speed can be balance-adjusted — see the Speed Balancing Adjustment in the Adjustments section near the back of this manual.*

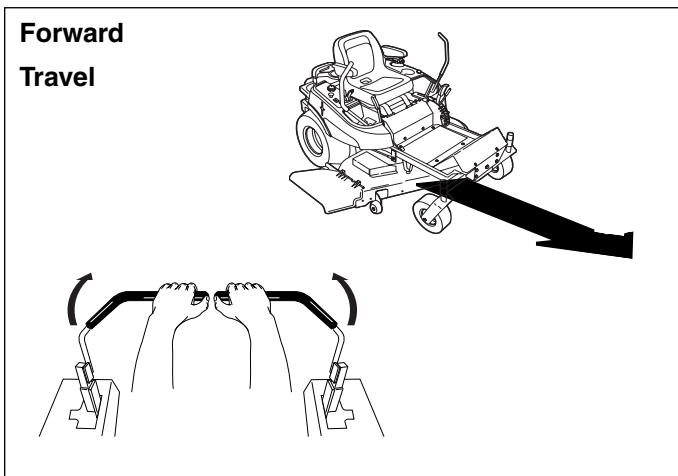

Figure 4. Forward Travel

### Smooth Travel

The lever controls of the zero turn rider are responsive .

The BEST method of handling the ground speed control levers is in three steps — as shown in Figure 3.

FIRST place your hands onto the levers as shown.

SECOND, to go forward gradually push the levers forward with your palms.

THIRD, to speed up move the levers farther forward. To slow down smoothly, slowly move the levers toward neutral.

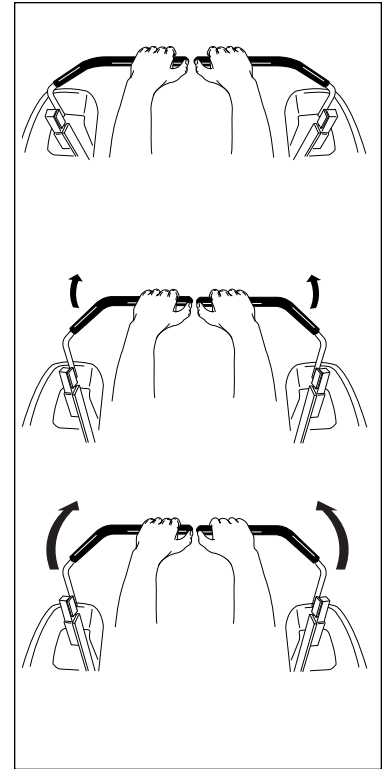

Figure 3. Move Control Levers Gradually

### Reverse Travel Practice

LOOK DOWN & BEHIND, then gradually move both ground speed control levers evenly BACK from neutral. Slow down and repeat.

*NOTE: Practice backing up for several minutes before attempting to do so near objects. The rider turns as sharply in reverse as when going forward, and backing up straight takes practice.*

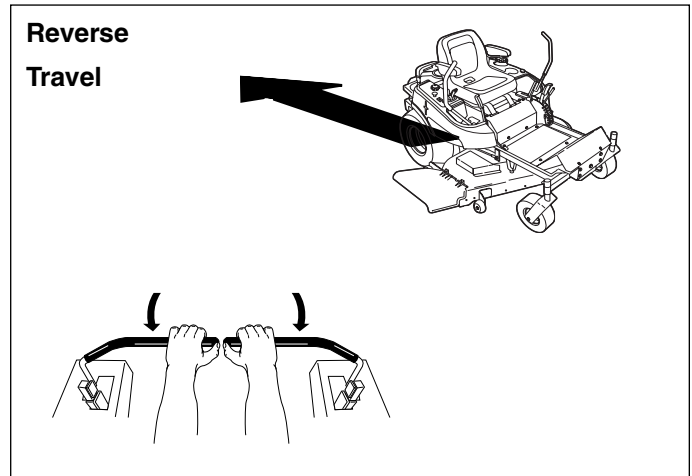

Figure 5. Reverse Travel

## Practice Turning Around a Corner

While traveling forward allow one handle to gradually return back toward neutral. Repeat several times.

*NOTE: To prevent pivoting directly on the tire tread, it is best to keep both wheels going at least slightly forward.*

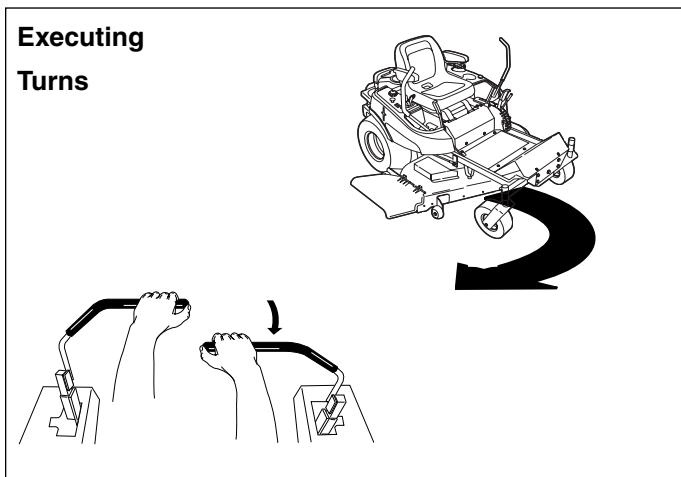

Figure 6. Turning Around a Corner

## Practice Turning In Place

To turn in place, “zero turn,” gradually move one ground speed control lever forward from neutral and one lever back from neutral simultaneously. Repeat several times.

*NOTE: Changing the amount each lever is pulled—forward or back, changes the “pivot point” you turn on.*

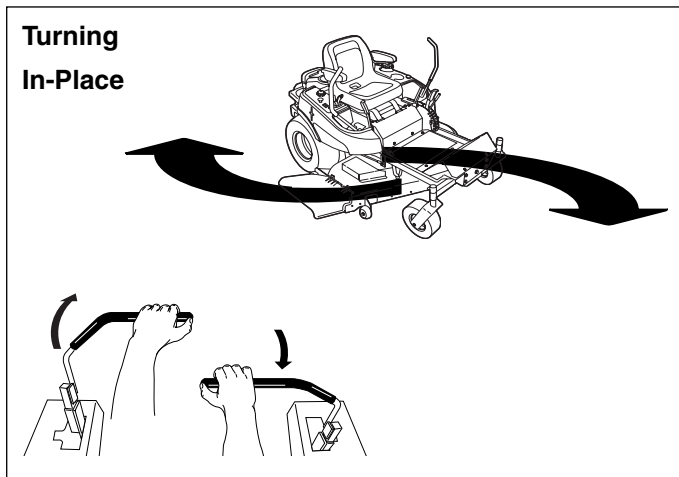

Figure 7. Turning in Place

## ADVANCED DRIVING

### Executing an End-Of-Row Zero Turn

Your zero turn rider’s unique ability to turn in place allows you to turn around at the end of a cutting row rather than having to stop and Y-turn before starting a new row.

For example, to execute a right end-of row zero turn:

1. Slow down at the end of the row.
2. Move the LEFT ground speed control lever forward slightly while moving the RIGHT ground speed control lever back to center and then slightly back from center.
3. Begin mowing forward again.

This technique turns the rider RIGHT and slightly overlaps the row just cut —eliminating the need to back up and re-cut missed grass.

*As you become more familiar and experienced with operating the zero turn rider, you will learn more maneuvers that will make your mowing time easier and more enjoyable.*

**Remember, the more you practice, the better your control of the rider will be!**

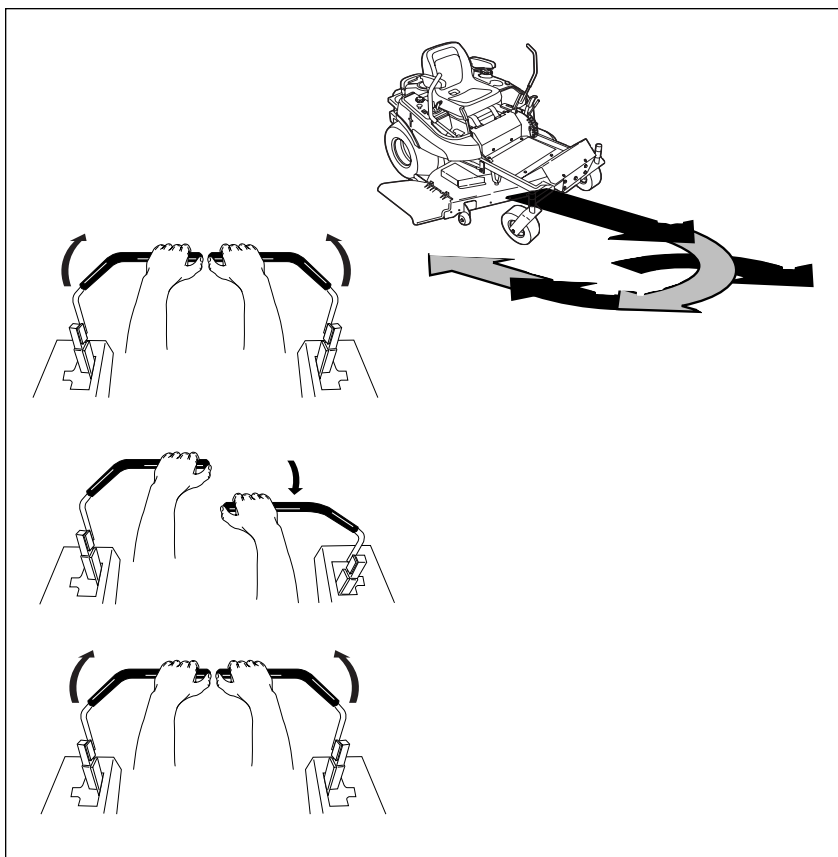
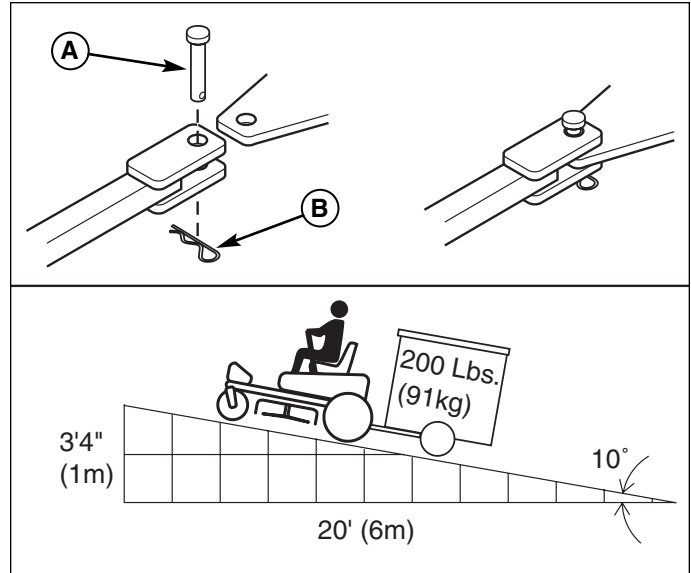

Figure 8. Executing an End-Of-Row Turn

## ATTACHING A TRAILER

The maximum weight of a towed trailer should be less than 200 lbs (91kg). Secure the trailer with an appropriately sized clevis pin (A, Figure 9) and clip (B).

Excessive towed loads can cause loss of traction and loss of control on slopes. Reduce towed weight when operating on slopes. The surface being driven on greatly impacts traction and stability. Wet or slippery surfaces can greatly reduce traction and the ability to stop or turn. Carefully evaluate the surface conditions before operating the unit and trailer, and never operate on slopes greater than 10 degrees. See SLOPE OPERATION and TOWED EQUIPMENT in the safety section of this manual for additional safety information.



**Figure 9. Trailer Weight Recommendations**

**A. Clevis Pin**

**B. Clip**

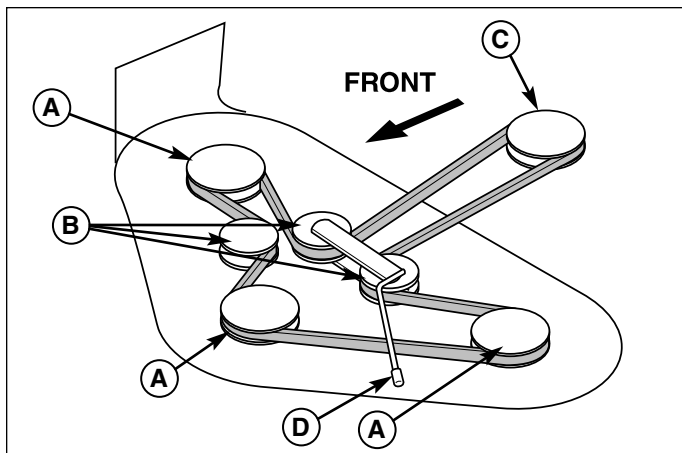

**Figure 10. Mower Belt Routing**

- A. Arbor Pulleys
- B. Back-Side Idlers
- C. PTO Pulley
- D. Belt Tension Release Lever

## MOWER REMOVAL AND INSTALLATION

*NOTE: Perform mower installation and removal on a hard flat surface such as a concrete floor.*

### Removal

1. Disengage the PTO, engage the parking brake, turn off the ignition, remove the key, and wait for all moving parts to stop.
2. Remove the cutting height pin and lower the attachment lift to its lowest position.
3. Pull the lever (A, Figure 11) towards the rear of the machine to release tension on the mower belt. Secure the lever in the guard notch (B) and remove the mower belt from the PTO pulley (C, Figure 10).
4. Pull the hair pins (C & D, Figure 12) and disconnect the deck leveling links (I & J). Pull and turn the rod locks (A, B, E & F) to release the rod ends.
5. Lift to front of the deck using a 2 x 4 as a lever, pull the handle (G) forward to release the front hangers rod ends (H), then push rearward to release the rear rod ends.
6. Pivot the front wheels out of the way and slide the mower deck out from under the unit.

### Installation

1. Disengage the PTO, engage the parking brake, turn off the ignition, remove the key, and wait for all moving parts to stop.
2. Remove the cutting height pin and lower the attachment lift to its lowest position.
3. Pivot the front wheels out of the way and slide the mower under the unit.
4. Install the leveling links and hair pins (I, J, C & D)
5. Lift the rear of the mower and install the rear lift rods (K & L) and secure with the rear rod locks (E & F).
6. Lift to front of the deck using a 2 x 4 as a lever, pull the handle (G) to align the front hanger rod ends (H) with the slots and secure with the front rod locks (A & B).

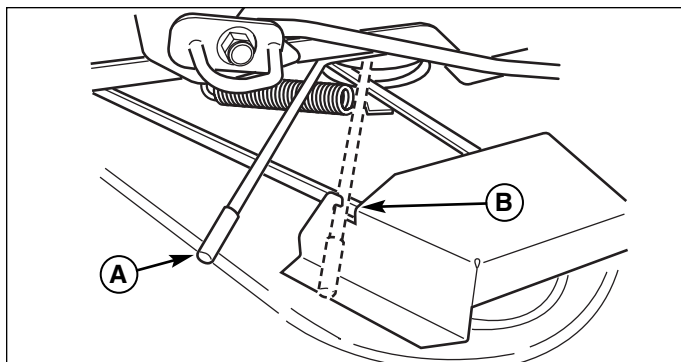

**Figure 11. Release Belt Tension**

- A. Belt Tension Release Lever
- B. Guard Notch

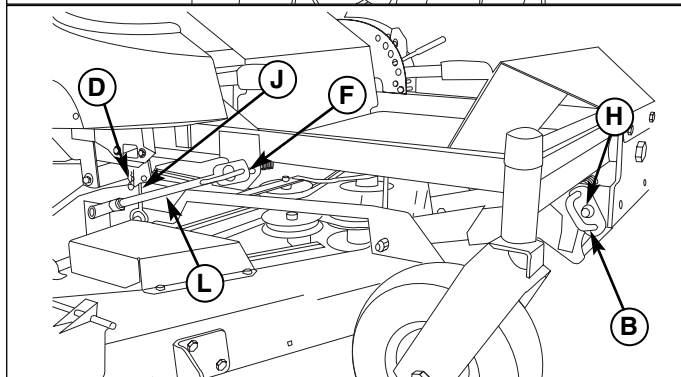
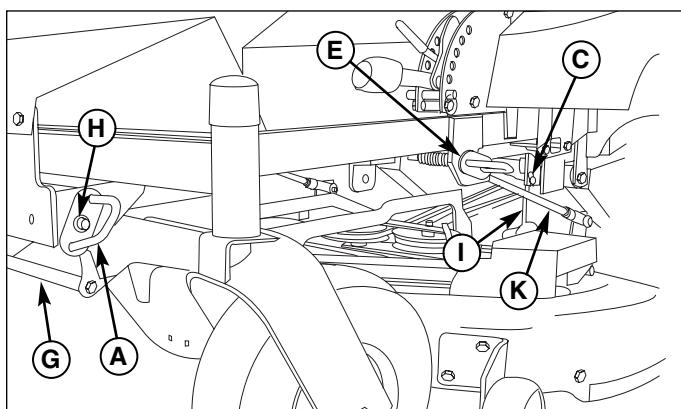

**Figure 12. Mower Installation & Removal**

- A. Left Front Rod Lock
- B. Right Front Rod Lock
- C. Left Leveling Link Hair Pin
- D. Right Leveling Link Hair Pin
- E. Left Rear Rod Lock
- F. Right Rear Rod Lock
- G. Handle
- H. Front Hanger Rod Ends
- I. Left Leveling Link
- J. Right Leveling Link
- K. Left Rear Lift Rod
- L. Right Rear Lift Rod

7. Install the belt as shown in Figure 10.
8. Release tension from the tensioning idler pulley using the belt tension lever (A, Figure 11) and make sure the belt is seated properly in all pulleys.



# Regular Maintenance

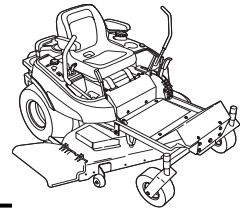

## MAINTENANCE SCHEDULE & PROCEDURES

The following schedule should be followed for normal care of your rider and mower. You will need to keep a record of your operating time. Determining operating time is easily accomplished by observing the elapsed time recorded by the hour meter.

<b>SAFETY ITEMS</b>	<b>Before Each Use</b>	<b>Every 5 Hours</b>	<b>Every 25 Hours</b>	<b>Every 100 Hours</b>	<b>Every 250 Hours</b>	<b>Spring &amp; Fall</b>
Check Safety Interlock System	•					•
Check Rider Brakes	•					•
Check Mower Blade Stopping Time				•		•
<b>RIDER MAINTENANCE ITEMS</b>	<b>Before Each Use</b>	<b>Every 5 Hours</b>	<b>Every 25 Hours</b>	<b>Every 100 Hours</b>	<b>Every 250 Hours</b>	<b>Spring &amp; Fall</b>
Check Rider / Mower for loose hardware		•				
Check / Clean Engine Cooling Fins			•			
Check / Adjust PTO Clutch			***	•		
Lubricate Rider & Mower **			•			
Clean Battery & Cables				•		
Check Tire Pressure			•			
Clean Deck & Check/Replace Mower Blades**			•			
Check Transmission Oil	•				•	
Change Transmission Oil Filter **					•	
<b>ENGINE MAINTENANCE ITEMS</b>	<b>Before Each Use</b>	<b>Every 5 Hours</b>	<b>Every 25 Hours</b>	<b>Every 100 Hours</b>	<b>Every 250 Hours</b>	<b>Spring &amp; Fall</b>
Check Engine Oil Level	•					
Check / Change Engine Air Filter *						
Change Engine Oil & Filter *						
Inspect Spark Plug(s) *						
Check / Replace Fuel Filter *						

\* Refer to engine owner's manual. Change original engine oil after initial break-in period.

\*\* More often in hot (over 85° F: 30° C) weather or dusty operating conditions.

\*\*\* Service after the first 25 hours of operation, then every 100 hours of operation.

## LUBRICATION

Lubricate the unit at the following lubrication points shown in Figure 13.

### Grease:



- front caster wheel axles
- front caster yokes
- mower deck idler arm
- mower deck arbors

Use grease fittings when present. Disassemble parts to apply grease to moving parts when grease fittings are not installed.

Not all greases are compatible. Use automotive-type lithium grease.

### Oil:



- control handle pivots
- discharge chute hinge

Generally, all moving metal parts should be oiled where contact is made with other parts. Keep oil and grease off belts and pulleys. Remember to wipe fittings and surfaces clean both before and after lubrication.

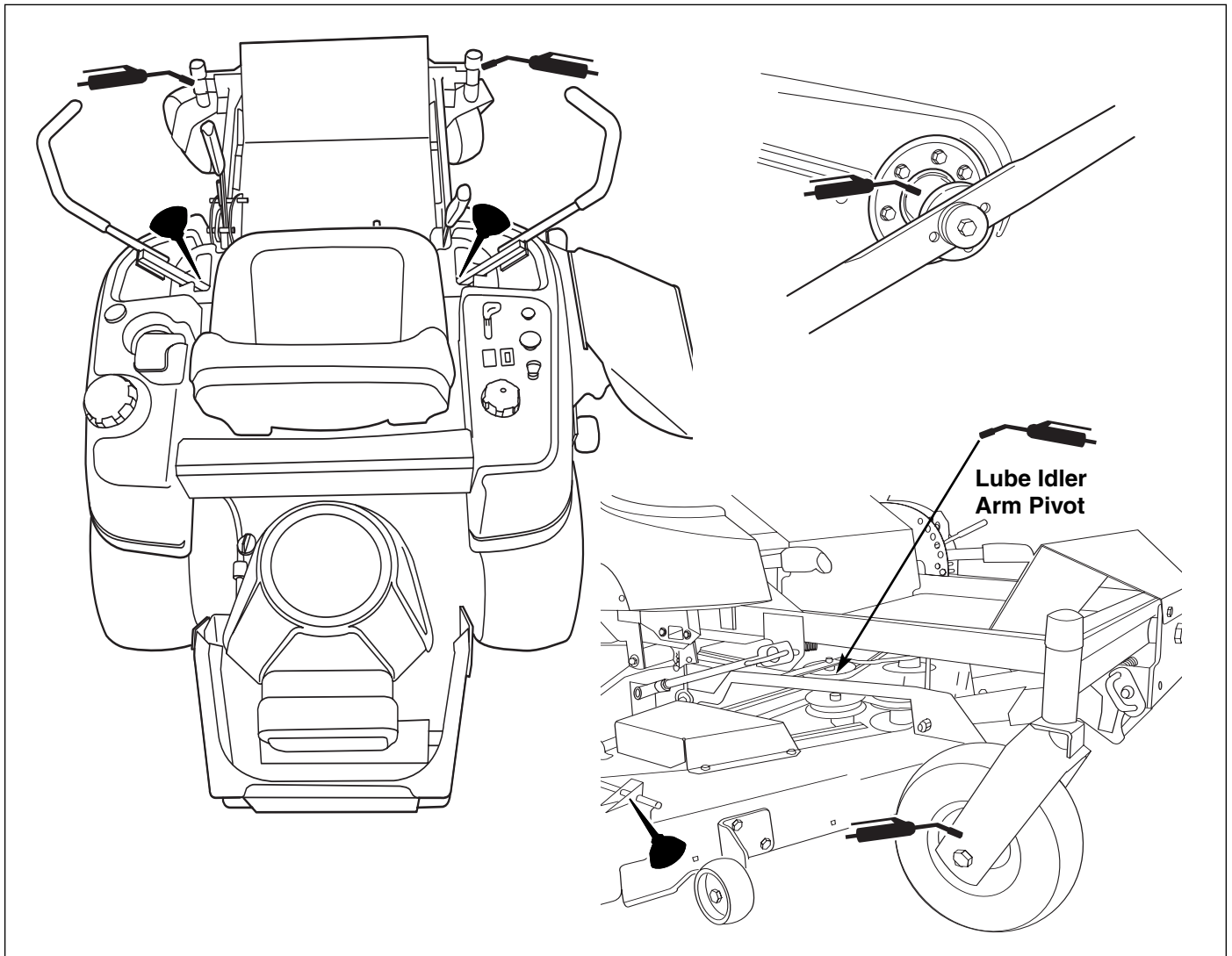

Figure 13. Lubrication

## Regular Maintenance

### **! WARNING**

For your personal safety, do not handle the sharp mower blades with bare hands. Careless or improper handling of blades may result in serious injury.

### **! WARNING**

For your personal safety, blade mounting capscrews must each be installed with a hex/spline washer and spring washer, then securely tightened. Torque blade mounting capscrew to 45 - 55 ft. lbs. (61 - 75 N.m.)

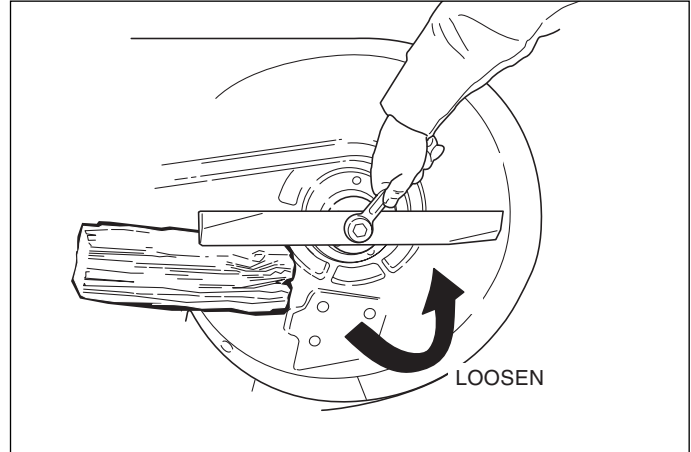

Figure 14. Blade Removal

## SERVICING THE MOWER BLADES

### Service Interval: Every 10 Hours or As Required

1. Remove mower deck (see "Mower Deck Removal").
2. See Figure 14. To remove blade for sharpening, use a block of wood to prevent blade rotation while loosening the capscrew.
3. Remove the capscrew (D, Figure 16), spring washer (C), hex washer (B), and blade.
4. Use a file to sharpen blade to a fine edge. If blade is damaged, it must be replaced.
5. Balance the blade as shown in Figure 15. Center the blade's hole on a nail lubricated with a drop of oil. A balanced blade will remain level.
6. Reinstall the blade (Figure 16) with the tabs pointing up toward the mower deck as shown.
7. Reinstall the hex washer (B, Figure 16), spring washer (C) and capscrew (D). Use a wooden block (A) to prevent blade rotation while tightening the capscrew (D) to 61-75 N.m (45-55 ft. lbs.).

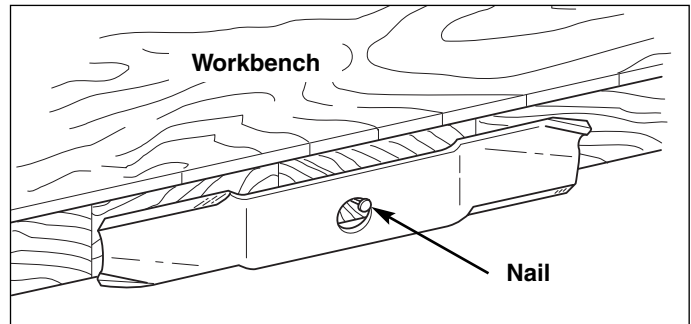

Figure 15. Balancing The Blade

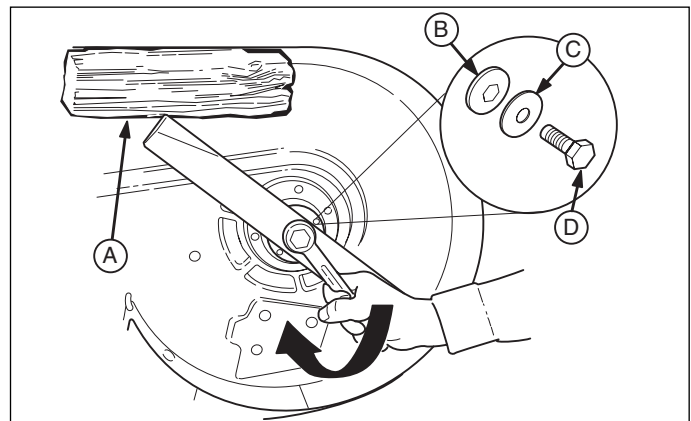

Figure 16. Blade Installation

- A. 4x4 Wood Block
- B. Hex Washer
- C. Spring Washer
- D. Blade Capscrew

## CHECK TIRE PRESSURES

Tire pressure should be checked periodically, and maintained at the levels shown in the chart. Note that these pressures may differ slightly from the “Max Inflation” stamped on the side-wall of the tires. The pressures shown provide proper traction, improve cut quality, and extend tire life.

## CHECKING / ADDING FUEL

To add fuel:

1. Remove the fuel cap (see A, Figure 18).
2. Fill the tank to the bottom of the filler neck. This will allow for fuel expansion.

*NOTE: Do not overfill. Refer to your engine manual for specific fuel recommendations.*

3. Install and hand tighten the fuel cap.

## FUEL FILTER

The fuel filter is located in the fuel line between fuel tank and fuel pump. If the filter is dirty or clogged, replace as follows:

1. Disconnect the negative battery cable.
2. Place a container below the filter to catch spilled fuel.
3. Using a pliers, open and slide hose clamps from fuel filter (C, Figure 18).
4. Remove hoses from filter.
5. Install new filter in proper flow direction in fuel line.
6. Secure with hose clamps.
7. Reconnect the negative battery cable when finished.

## ENGINE MAINTENANCE

Refer to engine owners manual for all engine maintenance procedures and recommendations.

## CHECK /FILL TRANSMISSION OIL

**Oil Type:** Mobil 1™ 15W-50 synthetic oil, Castrol Syntec™ 5W-50 oil, or 20W-50 conventional detergent motor oil.

1. Check the oil level when the unit is cold. The inspection port is located on the inside of the right tank cover. The oil level should be within 1/2" (1.3 cm) of the horizontal level mark (D, Figure 19). If the oil is below this level, proceed to step 2.
2. Before removing the reservoir cap, make sure the area around the reservoir cap and fill neck of the reservoir is free of dust, dirt, or other debris. Loosen the locking capscrew (E, Figure 18) securing the locking tab (D), slide the lock tab back, and remove the cap (B).
3. Add oil up to the full mark (D, Figure 19).

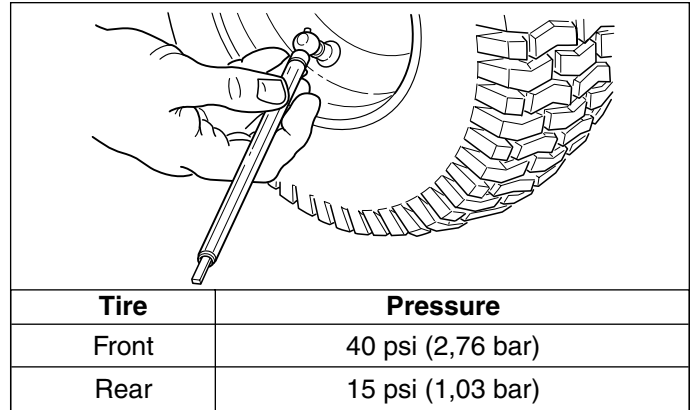

Figure 17. Checking Tire Pressure

## ! WARNING

**Gasoline is highly flammable and must be handled with care. Never fill the tank when the engine is still hot from recent operation. Do not allow open flame, smoking or matches in the area. Avoid over-filling and wipe up any spills. Do not remove fuel filter when engine is hot, as spilled gasoline may ignite. DO NOT spread hose clamps further than necessary. Ensure clamps grip hoses firmly over filter after installation.**



*Do not use gasoline containing METHANOL, gasohol containing more than 10% ethanol, gasoline additives, premium gasoline, or white gas because engine/fuel system damage could result.*

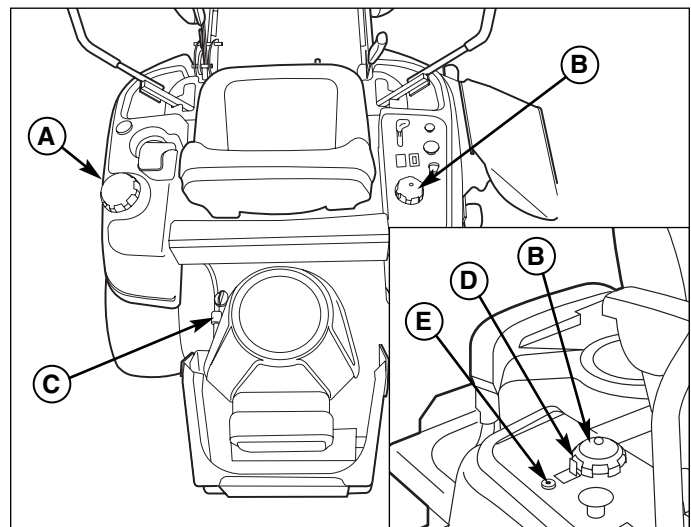

Figure 18. Maintenance

- A. Fuel Tank Cap
- B. Transmission Oil Cap
- C. Fuel Filter
- D. Locking Tab
- E. Locking Screw

## Regular Maintenance

4. Reinstall the reservoir cap, move the locking tab between two notches, and tighten the locking cap-screw.

### TRANSMISSION OIL FILTER CHANGE

**Change Interval:** Every 250 Hours

**Filter Part Number:** 1719168

1. Locate the transmission oil filter (C, Figure 19) at the rear of the battery compartment under the seat.
2. Lubricate the new filter base with a few drops of transmission oil. Fill the filter half full of oil.
3. Clean the area around the filter base and remove the filter. **Do NOT drain the hydraulic system oil.**
4. Thread the new filter onto the filter base until the gasket makes contact, then tighten 3/4 of a turn more.

*NOTE: The oil will drain from the reservoir tank if the new filter is not quickly reinstalled.*

5. Run the unit for several minutes and check the transmission oil level (see previous page).

*IMPORTANT NOTE: Use caution after changing the filter; air in the hydraulic system may affect the responsiveness of the control levers. Repeat step 5 until the air is out of the system.*

### BATTERY MAINTENANCE

#### Cleaning the Battery and Cables

1. Disconnect the cables from the battery, negative cable first (B, Figure 19).
2. Clean the battery terminals and cable ends with a wire brush until shiny.
3. Reinstall the battery and reattach the battery cables, positive cable first (see A, Figure 19)
4. Coat the cable ends and battery terminals with petroleum jelly or non-conducting grease.

### STORAGE

Before you store your unit for the off-season, read the Maintenance and Storage instructions in the Safety Rules section, then perform the following steps:

- Disengage the PTO, set the parking brake, & remove the key.
- Perform engine maintenance and storage measures listed in the engine owner's manual. This includes draining the fuel system, or adding stabilizer to the fuel (do not store a fueled unit in an enclosed structure - see warning).

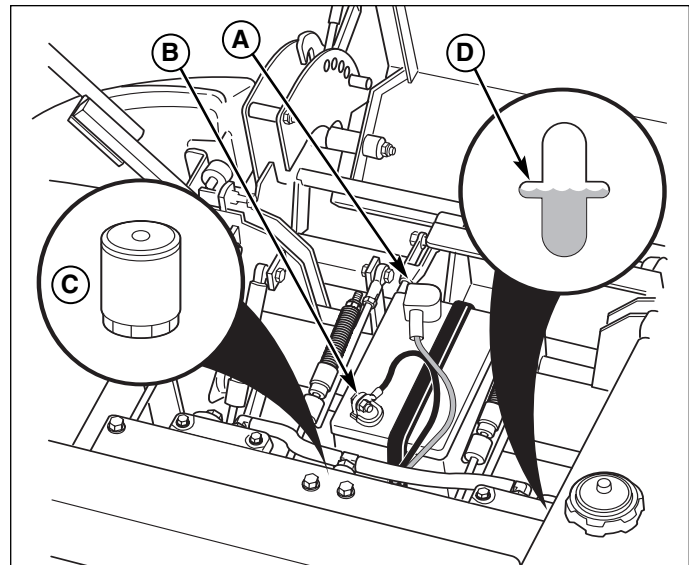

**Figure 19. Battery Compartment**

- A. Positive (+) Cable & Terminal**
- B. Negative (-) Cable & Terminal**
- C. Transmission Filter**
- D. Transmission Fill Level Mark**

### **!** WARNING

**Be careful when handling the battery. Avoid spilling electrolyte. Keep flames and sparks away from the battery.**

**When removing or installing battery cables, disconnect the negative cable FIRST and reconnect it LAST. If not done in this order, the positive terminal can be shorted to the frame by a tool.**

### **!** WARNING

**Never store the unit (with fuel) in an enclosed, poorly ventilated structure. Fuel vapors can travel to an ignition source (such as a furnace, water heater, etc.) and cause an explosion.**

**Fuel vapor is also toxic to humans and animals.**

- Battery life will be increased if it is removed, put in a cool, dry place and fully charged about once a month. If the battery is left in the unit, disconnect the negative cable.

Before starting the unit after it has been stored:

- Check all fluid levels. Check all maintenance items.
- Perform all recommended checks and procedures found in the engine owner's manual.
- Allow the engine to warm up for several minutes before use.

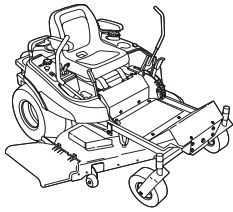

# Troubleshooting, Adjustments, & Service

## TROUBLESHOOTING

While normal care and regular maintenance will extend the life of your equipment, prolonged or constant use may eventually require that service be performed to allow it to continue operating properly.

The troubleshooting guide below lists the most common problems, their causes and remedies.

See the information on the following pages for instructions on how to perform most of these minor adjustments and service repairs yourself. If you prefer, all of these procedures can be performed for you by your local authorized dealer.

### WARNING

**To avoid serious injury, perform maintenance on the rider or mower only when the engine is stopped and the parking brake engaged. Always remove the ignition key, disconnect the spark plug wire and fasten it away from the plug before beginning the maintenance, to prevent accidental starting of the engine.**

## TROUBLESHOOTING THE RIDER

PROBLEM	CAUSE	REMEDY
<b>Engine will not turnover or start.</b>	<ol style="list-style-type: none"> <li>1. Parking brake not engaged.</li> <li>2. PTO (electric clutch) switch in ON position.</li> <li>3. Out of fuel.</li> <li>4. Engine flooded.</li> <li>5. Gas is old or stale.</li> <li>6. Battery terminals require cleaning.</li> <li>7. Battery discharged or dead.</li> <li>8. Wiring loose or broken.</li> <li>9. Solenoid or starter motor faulty.</li> <li>10. Safety interlock switch faulty.</li> <li>11. Spark plug(s) faulty, fouled or incorrectly gapped.</li> <li>12. Water in fuel.</li> </ol>	<ol style="list-style-type: none"> <li>1. Engage parking brake.</li> <li>2. Place in OFF position.</li> <li>3. If engine is hot, allow it to cool, then refill the fuel tank.</li> <li>4. Open the choke.</li> <li>5. Drain fuel &amp; replace with fresh fuel.</li> <li>6. Clean the battery terminals</li> <li>7. Recharge or replace.</li> <li>8. Visually check wiring &amp; replace broken or frayed wires. Tighten loose connections.</li> <li>9. Repair or replace. See authorized dealer</li> <li>10. Replace as needed. See authorized service dealer.</li> <li>11. Clean and gap or replace. See engine manual.</li> <li>12. Drain fuel &amp; refill with fresh fuel.</li> </ol>
<b>Engine starts hard or runs poorly.</b>	<ol style="list-style-type: none"> <li>1. Fuel mixture too rich.</li> <li>2. Spark plug faulty, fouled, or incorrectly gapped.</li> </ol>	<ol style="list-style-type: none"> <li>1. Clean air filter. Check the choke.</li> <li>2. Clean and gap or replace. (See engine manual.)</li> </ol>
<b>Engine knocks.</b>	<ol style="list-style-type: none"> <li>1. Low oil level.</li> <li>2. Using wrong grade oil.</li> </ol>	<ol style="list-style-type: none"> <li>1. Check/add oil as required.</li> <li>2. See engine manual.</li> </ol>
<b>Excessive oil consumption.</b>	<ol style="list-style-type: none"> <li>1. Engine running too hot.</li> <li>2. Using wrong weight oil.</li> <li>3. Too much oil in crankcase.</li> </ol>	<ol style="list-style-type: none"> <li>1. Clean engine fins, blower screen and air cleaner.</li> <li>2. See engine manual.</li> <li>3. Drain excess oil.</li> </ol>
<b>Engine exhaust is black.</b>	<ol style="list-style-type: none"> <li>1. Dirty air filter.</li> <li>2. Engine choke control is in closed position.</li> </ol>	<ol style="list-style-type: none"> <li>1. Replace air filter. See engine manual.</li> <li>2. Open choke control.</li> </ol>



# Troubleshooting, Adjustments, & Service

## Rider Troubleshooting Continued.

PROBLEM	CAUSE	REMEDY
Engine runs, but rider will not drive.	<ol style="list-style-type: none"> <li>1. Hydraulic release valve(s) in "open" position.</li> <li>2. Belt is broken.</li> <li>3. Drive belt slips.</li> <li>4. Brake is not fully released.</li> </ol>	<ol style="list-style-type: none"> <li>1. Turn valve(s) clockwise to close.</li> <li>2. See Drive Belt Replacement.</li> <li>3. See problem and cause below.</li> <li>4. See authorized service dealer</li> </ol>
Rider drive belt slips.	<ol style="list-style-type: none"> <li>1. Pulleys or belt greasy or oily.</li> <li>2. Belt stretched or worn.</li> </ol>	<ol style="list-style-type: none"> <li>1. Clean as required.</li> <li>2. Replace belt.</li> </ol>
Brake will not hold.	<ol style="list-style-type: none"> <li>1. Brake is incorrectly adjusted.</li> <li>2. Brake caliper pads worn.</li> </ol>	<ol style="list-style-type: none"> <li>1. See Brake Adjustment.</li> <li>2. See your dealer.</li> </ol>
Rider steers or handles poorly.	<ol style="list-style-type: none"> <li>1. Steering linkage is loose.</li> <li>2. Improper tire inflation.</li> </ol>	<ol style="list-style-type: none"> <li>1. Check and tighten any loose connections.</li> <li>2. See Regular Maintenance Section.</li> </ol>

## TROUBLESHOOTING THE MOWER

PROBLEM	CAUSE	REMEDY
Mower will not raise.	<ol style="list-style-type: none"> <li>1. Lift linkage not properly attached or damaged.</li> </ol>	<ol style="list-style-type: none"> <li>1. See authorized service dealer for repair.</li> </ol>
Mower cut is uneven.	<ol style="list-style-type: none"> <li>1. Mower not leveled properly.</li> <li>2. Rider tires not inflated equally or properly.</li> </ol>	<ol style="list-style-type: none"> <li>1. See Mower Adjustment.</li> <li>2. See Regular Maintenance Section.</li> </ol>
Mower cut is rough looking.	<ol style="list-style-type: none"> <li>1. Engine speed too slow.</li> <li>2. Ground speed too fast.</li> <li>3. Blades are dull.</li> <li>4. Mower drive belt slipping because it is oily or worn.</li> <li>5. Blades not properly fastened to arbors.</li> </ol>	<ol style="list-style-type: none"> <li>1. Set throttle to full.</li> <li>2. Decrease Ground Speed.</li> <li>3. Sharpen or replace blades. See Mower Blade Service.</li> <li>4. Clean or replace belt as necessary.</li> <li>5. See Servicing the Mower Blades.</li> </ol>
Engine stalls easily with mower engaged.	<ol style="list-style-type: none"> <li>1. Engine speed too slow.</li> <li>2. Ground speed too fast.</li> <li>3. Cutting height set too low.</li> <li>4. Discharge chute jamming with cut grass.</li> </ol>	<ol style="list-style-type: none"> <li>1. Set to full throttle.</li> <li>2. Decrease Ground Speed.</li> <li>3. Cut tall grass at maximum cutting height during first pass.</li> <li>4. Cut grass with discharge pointing toward previously cut area.</li> </ol>
Excessive mower vibration.	<ol style="list-style-type: none"> <li>1. Blade mounting bolts are loose.</li> <li>2. Mower blades, arbors, or pulleys are bent.</li> <li>3. Mower blades are out of balance.</li> <li>4. Belt installed incorrectly.</li> </ol>	<ol style="list-style-type: none"> <li>1. Tighten to 45-55 ft.lbs. (61-75 N.m.).</li> <li>2. Check and replace as necessary.</li> <li>3. Remove, sharpen, and balance blades. See Maintenance Section.</li> <li>4. Reinstall Correctly.</li> </ol>
Excessive belt wear or breakage.	<ol style="list-style-type: none"> <li>1. Bent or rough pulleys.</li> <li>2. Using incorrect belt.</li> </ol>	<ol style="list-style-type: none"> <li>1. Repair or replace.</li> <li>2. Replace with correct belt.</li> </ol>
Mower drive belt slips or fails to drive.	<ol style="list-style-type: none"> <li>1. Idler pulley spring broken or not properly attached.</li> <li>2. Mower drive belt broken.</li> </ol>	<ol style="list-style-type: none"> <li>1. Repair or replace as needed.</li> <li>2. Replace drive belt.</li> </ol>

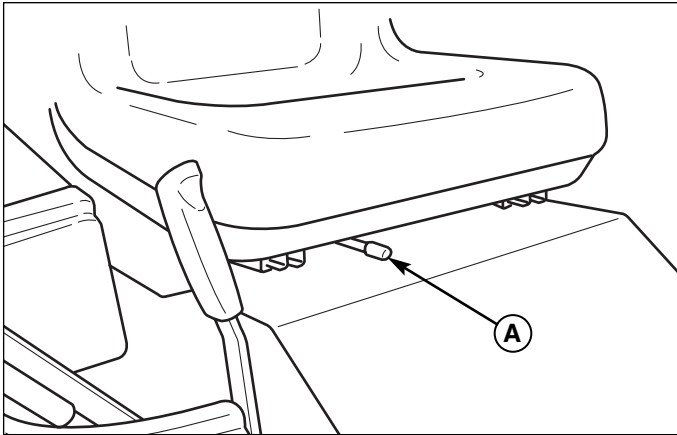

**Figure 20. Seat Adjustment**  
A. Adjustment Lever

## SEAT ADJUSTMENT

The seat and ground speed control levers should be adjusted so that operator's elbows are supported by the arm rests when his/her hands are on the controls, and the ground speed control levers can be moved through their full range of motion without contacting the operator's legs.

### Seat Position Adjustment

The seat can be adjusted forward and back. Move the adjustment lever (A, Figure 20) towards the left hand side of the machine, slide the seat to the desired position, and release the lever.

## GROUND SPEED CONTROL LEVER ADJUSTMENT

The control levers can be adjusted in three ways. The alignment of the control levers, the placement of the levers (how close the ends are to one another) and the height of the levers can be adjusted.

**To Adjust the Handle Alignment:** Loosen the mount bolts (A, Figure 21) and pivot the lever(s) (C) to align with each other.

**To Adjust the Handle Placement:** Loosen the jam nuts and adjust the placement bolt (B, Figure 21) in or out to properly adjust the lever end spacing.

**To Adjust the Handle Height:** Remove the mounting hardware and reposition the handle either up or down from its original position. You will need to readjust the handle alignment as described above.

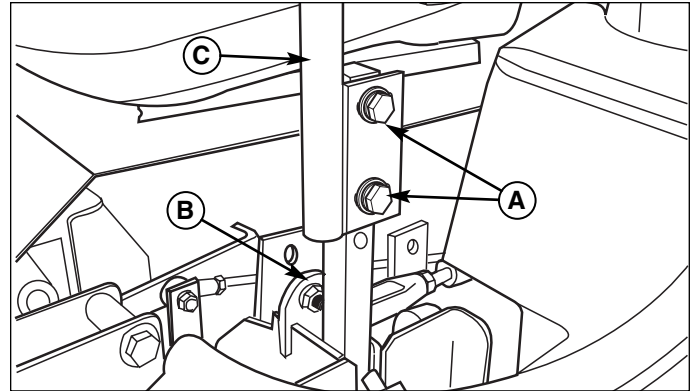

**Figure 21. Control Lever Adjustment**  
A. Alignment Hardware  
B. Placement Hardware  
C. Ground Speed Control Lever

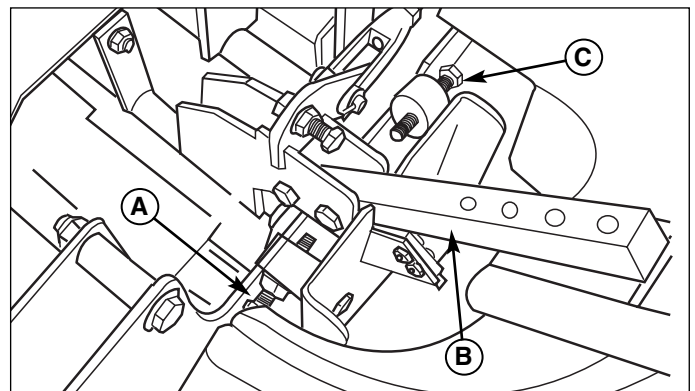

**Figure 22. Top Speed Adjustment**  
A. Forward Top Speed Adjustment Bolt  
B. Control Lever Base  
C. Reverse Top Speed Adjustment Bolt

## SPEED BALANCING ADJUSTMENT

### ⚠ WARNING

**DO NOT adjust the rider for a faster overall speed forward or reverse than it was designed for.**

If the rider veers to the right or left when the ground speed control levers are in the maximum forward or reverse position, the top speed of each of these levers can be balanced by turning the adjustment bolt(s) (A & C Figure 22). Only adjust the speed of the wheel that is traveling faster.

#### TO REDUCE THE SPEED OF THE FASTER WHEEL

1. Loosen the jam nut securing the top speed adjustment bolt (A, C).
2. Turn the top speed adjustment bolt COUNTER-CLOCKWISE to reduce the speed.
3. Retighten the securing nut when adjustment is complete.

# Troubleshooting, Adjustments, & Service

## CUTTING HEIGHT ADJUSTMENT

The cutting height adjustment pin (A, Figure 23) controls the mower cutting height. The cutting height is adjustable between 1-1/2" (3,8 cm) and 4-1/2" (11,4cm). Pulling the lever back fully locks the control in transport position.

To adjust cutting height:

1. Pull the adjustment lever (B, Figure 23) back fully until it locks in transport position.
2. Remove the cutting height adjustment pin (A) and insert it into the desired hole.
3. Pull back on the adjustment lever (B), squeeze the smaller transport release lever (C), and allow the lever to move forward until it is supported by the cutting height adjustment pin (A).

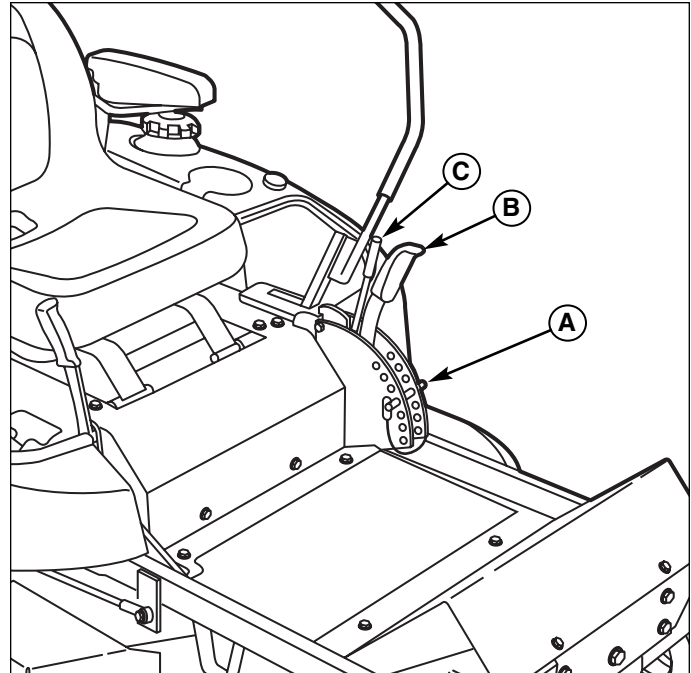
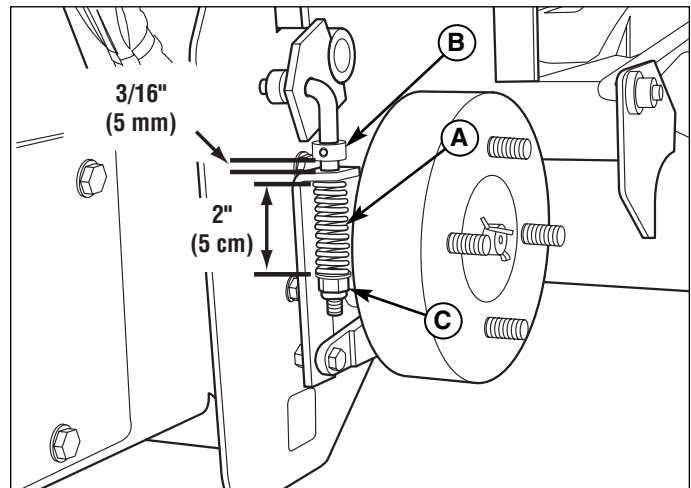

**Figure 23. Cutting Height Adjustment**  
A. Cutting Height Adjustment Pin  
B. Deck Lift / Cutting Height Lever  
C. Transport Release Lever

## PARKING BRAKE ADJUSTMENT

### Brake Adjustment

1. Disengage the PTO, stop the engine, block the front wheels, remove the ignition key, and engage the parking brake.
2. Elevate the rear end of the unit and remove the rear wheels.
3. Check the brake spring (A, Figure 24) length (both wheels). With the brake engaged the compressed spring length should be 2" (5 cm). If not, adjust the locknut (C, Figure 24) to achieve the compressed spring length of 2" (5 cm).
4. After achieving the correct spring compression, check the set collar gap (B, Figure 24). With the parking brake engaged, the set collar gap should be 3/16" (5 mm). If not, loosen the set collar screw and move the collar to the correct position.



**Figure 24. Parking Brake Adjustment**  
A. Brake Spring  
B. Set Collar  
C. Locknut

## NEUTRAL ADJUSTMENT

If the unit creeps forward or backward with the control levers in their neutral positions, see your dealer.

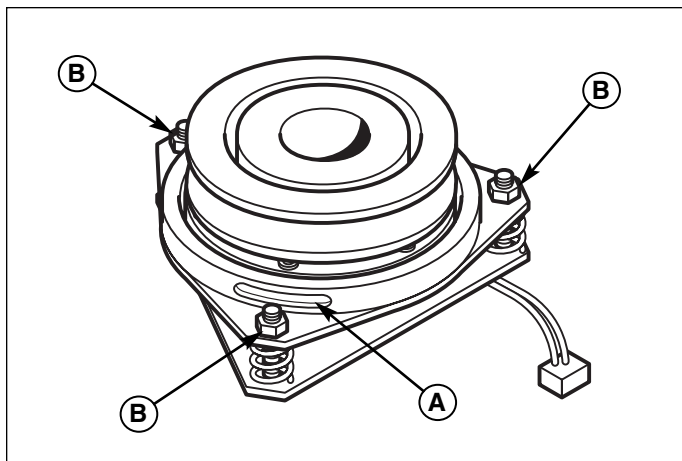

**Figure 25. PTO Clutch Adjustment**  
**A. Adjustment Window (Qty. 3, one shown)**  
**B. Adjustment Nut**

## PTO CLUTCH ADJUSTMENT

Check the PTO clutch adjustment after the initial 25 hour break-in period and then after every 100 hours of operation. Also perform the following procedure if the clutch is slipping or will not engage, or if a new clutch has been installed.

1. Remove key from ignition switch and disconnect spark plug wires to prevent the possibility of accidental starting while the PTO is being adjusted.
2. See Figure 25. Note the position of the 3 adjustment windows (A) in the side of the brake plate and the nylock adjustment nuts (B).
3. Insert a .016"-.018" (0,40-0,45mm) feeler gauge (C) through each window, positioning the gauge between the rotor face and the armature face as shown in Figure 26.
4. Alternately tighten the adjustment nuts (B, Figure 25) until the rotor face and armature face just contacts the gauge.
5. Check the windows for an equal amount of tension when the gauge is inserted and removed, and make any necessary adjustments by tightening or loosening the adjustment nuts.

*NOTE: The actual air gap between the rotor and armature may vary even after performing the adjustment procedure. This is due to dimensional variations on component parts, and is an acceptable condition.*

6. Check the mower blade stopping time. The mower blades and mower drive belt should come to a complete stop within five (5) seconds after the electric PTO switch is turned off.

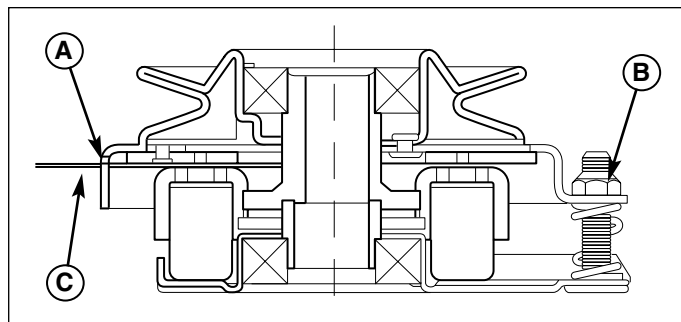

**Figure 26. Adjust PTO Clutch**  
**A. Window**  
**B. Adjustment Nut**  
**C. .016"-.018" (0,40-0,45mm) Feeler Gauge**

## **⚠ WARNING**

**To avoid serious injury, perform adjustments only with engine stopped, key removed and rider on level ground.**

## BLADE BRAKE CHECK

Mower blades and mower drive belt should come to a complete stop within five (5) seconds after electric PTO switch is turned off.

1. With parking brake engaged, PTO disengaged and an operator in the seat, start the engine.
2. Have an assistant observe the mower drive belt through the opening between the frame and top of mower deck. Engage the PTO and wait several seconds. Disengage the PTO and check the amount of time it takes for the mower drive belt to stop.
3. If the mower drive belt does not stop within five (5) seconds, perform the PTO Clutch Adjustment. If the belt still does not stop within five (5) seconds, see your dealer.

## MOWER DECK LEVELING

Perform these adjustments on a flat level surface.

### SIDE-TO-SIDE LEVELING

1. With the mower installed, place the rider on a smooth, level surface such as a concrete floor. Turn the front wheels so they are straight.
2. Check for bent blades and replace if necessary.
3. Place the mower cutting height pin in the 4th hole from the bottom (see insert, Figure 29). Arrange the outside mower blades so that they are pointing from side-to-side (Figure 27).
4. Measure the distance between the outside tips of each blade and the ground (Figures 27 & 28). If there is more than 1/8" (3mm) difference between the measurements on each side, proceed to step 5. If the difference is 1/8" (3mm) or less, proceed to step 6.
5. Use the rear leveling links (B, Figure 29) to adjust the side-to-side leveling of the deck. Repeat step 4 if necessary.

### FRONT-TO-BACK LEVELING

6. Arrange the blades so they face front-to-back (Figure 30).
7. Measure the distance from the ground to the front tip of the center blade, and from the ground to rear tips of left-hand and right-hand blades (Figures 28 & 30). The front tip of the center blade should be 1/4" (6mm) higher than rear tips of left-hand and right-hand blades. If not, proceed with steps 8 - 11.
8. Check the length of the hanging rods. The rear (D, Figure 29) should be 15" (38,1cm) and is not adjusted. To adjust the pitch of the mower deck, adjust the front leveling nuts only.
9. Loosen the front lock nuts (E, Figure 29).
10. Turn the leveling nuts (A, Figure 29) counter-clockwise to lower the front of mower deck. Turn the nuts clockwise to raise the front of the mower. Make adjustments in small increments, trying to keep tension on both leveling nuts.
11. Tighten the front lock nuts (E).
12. Re-check the blade measurement then repeat steps 7-11 as necessary.

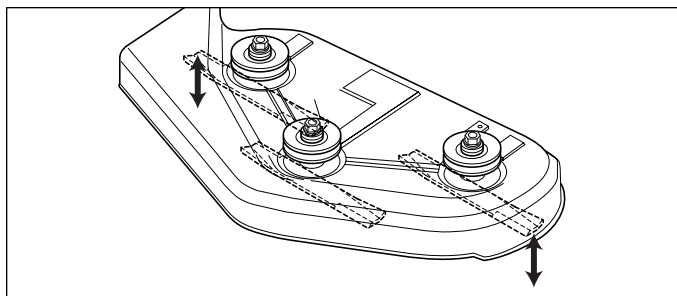

Figure 27. Orient Blades Side-to-Side

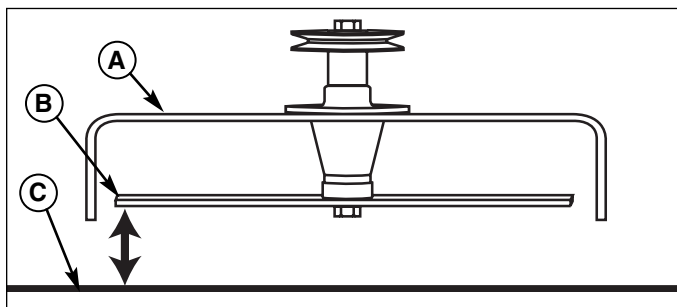

Figure 28. Measure Blade Tips to Ground  
A. Mower Deck                      C. Level Ground  
B. Blade Tip

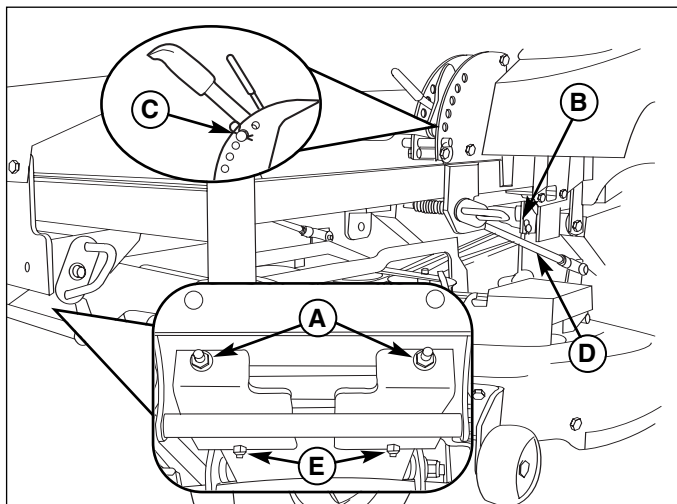

Figure 29. Mower Leveling  
A. Front Leveling Nuts  
B. Rear Leveling Rods  
C. 4th Cutting Height Hole  
D. Rear Hanger Rods  
E. Front Lock Nuts

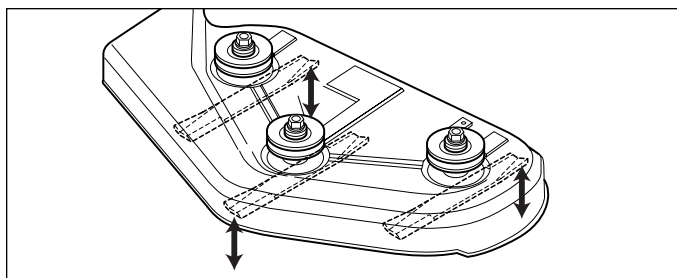
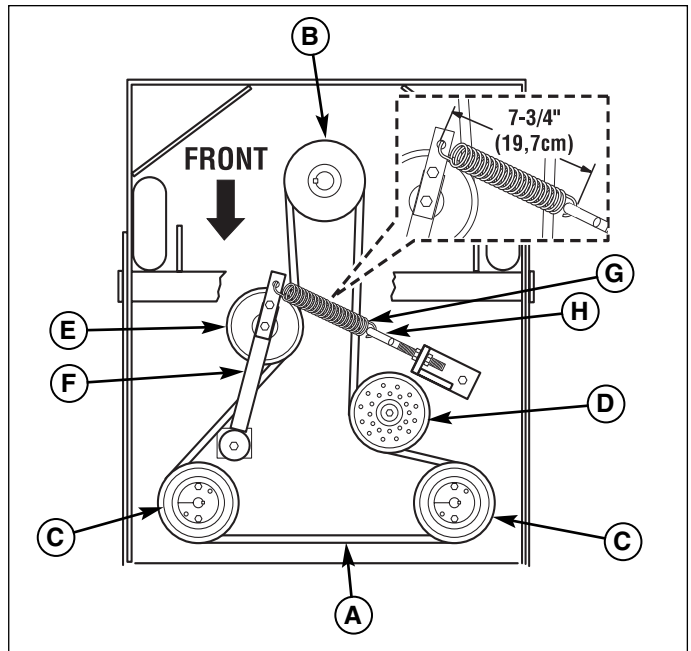

Figure 30. Orient Blades Front-to-Back

## HYDRAULIC PUMP DRIVE BELT REPLACEMENT

1. Park the rider on a smooth, level surface such as a concrete floor. Disengage the PTO, engage the parking brake, turn off the engine, and remove the ignition key.
2. Remove the PTO drive belt (see MOWER BELT REPLACEMENT for removal instructions).
3. Loosen the nut towards the front of the machine on the spring anchor hook (H, Figure 31) to release the majority of the belt tension. Use caution and remove the nut to completely release the tension.
4. Remove the old belt and replace it with the new one. Make sure the V-side of the belt runs in the grooves of the crankshaft pulley and pump pulleys (B & C).
5. Reinstall the anchor hook (H) into the anchor tab and loosely fasten the nut. Adjust the spring until a measurement of 7-3/4" (19,7cm) is achieved from the outside of the spring hooks. Tighten nut.
6. Reinstall the PTO drive belt.



**Figure 31. Hydraulic Pump Drive Belt Replacement (Shown from Below)**

- A. Pump Drive Belt
- B. Crankshaft Pulley
- C. Pump Pulley
- D. Idler Pulley (stationary)
- E. Idler Pulley
- F. Idler Arm
- G. Spring
- H. Spring Anchor Hook

## BATTERY CHARGING

A dead battery or one too weak to start the engine may be the result of a defect in the charging system or other electrical component. If there is any doubt about the cause of the problem, see your dealer. If you need to replace the battery, follow the steps under Cleaning the Battery & Cables in the Regular Maintenance Section.

To charge the battery, follow the instructions provided by the battery charger manufacturer as well as all warnings included in the safety rules sections of this book. Charge the battery until fully charged (until the specific gravity of the electrolyte is 1.250 or higher and the electrolyte temperature is at least 60° F). Do not charge at a rate higher than 10 amps.

### **! WARNING**

**Keep open flames and sparks away from the battery; the gasses coming from it are highly explosive. Ventilate the battery well during charging.**



## MOWER BELT REPLACEMENT



To avoid damaging belts, DO NOT PRY BELTS OVER PULLEYS.

1. Park the rider on a smooth, level surface such as a concrete floor. Disengage the PTO, engage the parking brake, turn off the engine, and remove the ignition key.
2. Raise the mower deck to transport position. Pull the lever (A, Figure 33) towards the rear of the machine to release tension on the mower belt. Secure the lever in the guard notch (B).
3. Remove the old drive belt and install the new one as shown in Figure 32. Note that the back of the drive belt must ride against the back-side idler pulleys (B). Use the belt tension lever (A, Figure 33) to release tension on the idler pulley for installation.

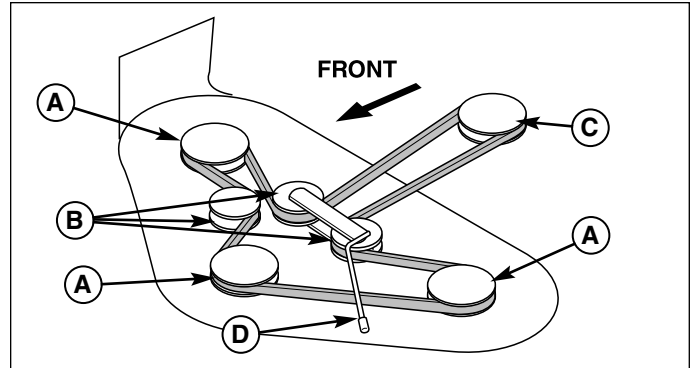

**Figure 32. Mower Belt Routing**

- A. Arbor Pulleys**
- B. Back-Side Idler Pulleys**
- C. PTO Pulley**
- D. Belt Tension Release Lever**

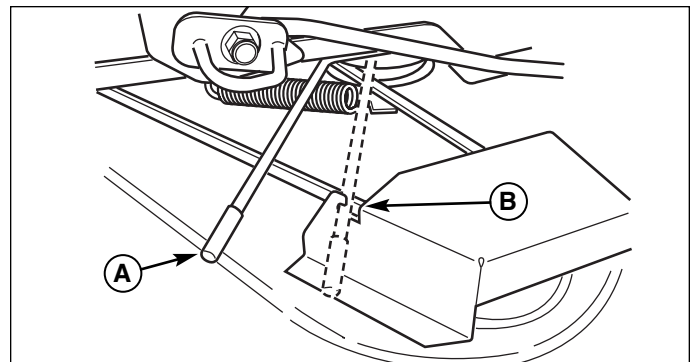

**Figure 33. Release Belt Tension**

- A. Belt Tension Release Lever**
- B. Guard Notch**

# SNAPPER PRODUCT REGISTRATION FORM

**IMPORTANT: KEEP THIS INFORMATION FOR YOUR PERSONAL RECORDS  
(Complete the following information on your Snapper purchase)**

**Model Number** \_\_\_\_\_

**Serial Number** \_\_\_\_\_

**Date of Purchase** \_\_\_\_\_

**Retailer** \_\_\_\_\_

**Retailer's Phone Number** \_\_\_\_\_

**It is very important that you register your purchase with Snapper to ensure warranty coverage. Please mail your product registration card to:**

**Snapper at P.O. Box 1379, McDonough, Georgia 30253.**

**Or you may register on line at [www.snapper.com](http://www.snapper.com).**

**You can contact us at our web site or if you would like to speak with a Customer Service Representative. Call us at the Snapper Customer Relations Center. For faster service please have your Serial Number and Model Number available.**

**Call the Snapper Customer Relations Center at 1-800-935-2967.**

# **SNAPPER®**

## **2 YEAR LIMITED WARRANTY**

For two (2) years from purchase date for the original purchaser's residential, non-commercial use, **SNAPPER**, through any authorized **SNAPPER** dealer will replace, free of charge (except for taxes where applicable), any part or parts found upon examination by the factory at McDonough, Georgia, to be defective in material or workmanship or both.

For ninety (90) days from purchase date for the original purchaser's commercial, rental, or other non-residential use, **SNAPPER**, through any authorized **SNAPPER** dealer will replace, free of charge, any part or parts found upon examination by the factory at McDonough, Georgia, to be defective in material or workmanship or both.

All transportation costs incurred by the purchaser in submitting material to an authorized **SNAPPER** dealer for replacement under this warranty must be paid by the purchaser.

This warranty does not apply to certain transmissions, to engines and their components, and batteries, as these items are warranted separately. This warranty does not apply to parts that have been damaged by accident, alteration, abuse, improper lubrication, normal wear, or other cause beyond the control of **SNAPPER**. This warranty does not cover any machine or component part that has been altered or modified changing safety, performance, or durability.

Batteries have a one (1) year warranty period with free replacement if required for one (1) year from the original purchase date. **SNAPPER** will not be responsible for any installation cost incurred. The battery warranty only covers original equipment batteries and does not cover damage to the battery or machine caused by neglect or abuse, destruction by fire, explosion, freezing, overcharging, improper maintenance, or use of improper electrolyte.

There is no other express warranty.

### **DISCLAIMER OF WARRANTY**

Implied warranties, including those of merchantability and fitness for a particular purpose, are limited to two (2) years from purchase date for the original purchaser's residential or other non-commercial use, and ninety (90) days from purchase for the original purchaser's commercial, rental or other non-residential use, and to the extent permitted by law, any and all implied warranties are excluded. This is the exclusive remedy. Liabilities for consequential damages, under any and all warranties are excluded.

Some states do not allow limitations on how long an implied warranty lasts, or do not allow the exclusion or limitation of incidental or consequential damages, so the above limitation or exclusion may not apply to you.

This warranty gives you specific legal rights, and you may also have other rights which vary from state to state.

**WARNING: THE USE OF REPLACEMENT PARTS OTHER THAN GENUINE SNAPPER PARTS MAY IMPAIR THE SAFETY OF SNAPPER PRODUCTS AND WILL VOID ANY LIABILITY AND WARRANTY BY SNAPPER ASSOCIATED WITH THE USE OF SUCH PARTS.**

**IMPORTANT:** Please fill out the attached **SNAPPER** Product Registration Card immediately and mail to:  
**Snapper's Product Registration Center, P.O. Box 1379, McDonough, Georgia 30253**

# ***Safety Instructions & Operator's Manual for***

# ***SNAPPER***®

## ***FastCut HYDRO DRIVE ZTR***

## ***SERIES 1***

### **IMPORTANT**

Snapper products are built using engines that meet or exceed all applicable emissions requirements on the date manufactured. The label on those engines contain very important emissions information and critical safety warnings. Read, Understand, and Follow all warnings and instructions in this manual, the engine manual, and on the machine, engine and attachments. If you have any questions about your Snapper product, contact your local authorized Snapper dealer or contact Snapper Customer Service at Snapper, McDonough, GA. 30253. Phone: (1-800-935-2967).



#### **WARNING**

**BATTERY POSTS, TERMINALS AND RELATED ACCESSORIES CONTAIN LEAD AND LEAD COMPOUNDS, CHEMICALS KNOWN TO THE STATE OF CALIFORNIA TO CAUSE CANCER AND BIRTH DEFECTS OR OTHER REPRODUCTIVE HARM. WASH HANDS AFTER HANDLING.**



#### **WARNING**

**ENGINE EXHAUST, SOME OF ITS CONSTITUENTS, AND CERTAIN VEHICLE COMPONENTS CONTAIN OR EMIT CHEMICALS KNOWN TO THE STATE OF CALIFORNIA TO CAUSE CANCER OR OTHER REPRODUCTIVE HARM.**

***SNAPPER***® McDonough, GA 30253 USA