

Safety Instructions & Operator's Manual for
SNAPPER[®]
YARD CRUISER

HYDRO DRIVE
SERIES 1 & 2

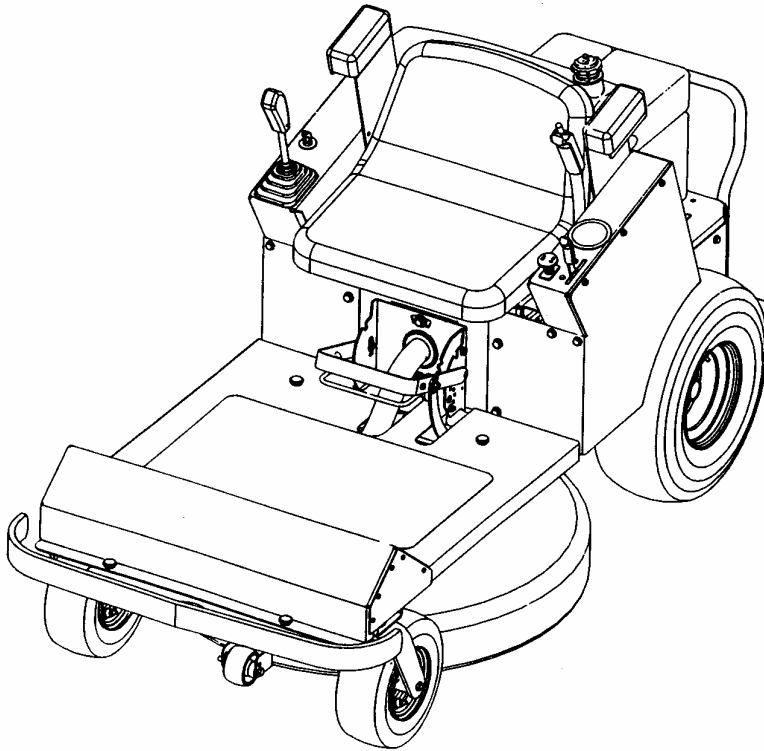

MODELS
YZ13331BE
YZ13381BE
YZ145332BE
YZ145382BE

MODEL NUMBER EXPLANATION

Y Z 13 33 1 B E

MODEL DESIGNATION _____
 DRIVE SYSTEM TYPE _____
 ENGINE HORSE POWER _____
 CUTTING WIDTH _____

ENGINE OPTIONS _____
 ENGINE TYPE _____
 SERIES DESIGNATION _____

Y - Yard Cruiser Z - Zero Turning Radius	13 - 13.0 HP Engine 145 - 14.5 HP Engine	33 - 33" Cutting Deck 38 - 38" Cutting Deck	1 - Series Designation 2 - Series Designation	B - Briggs Engine	E - Electric Start
---	---	--	--	-------------------	--------------------

Thank you for buying a SNAPPER Product! Before operating your YARD CRUISER, read this manual carefully and pay particular attention to the "IMPORTANT SAFETY INSTRUCTIONS" on Pages 2 & 3. Remember that all power equipment can be dangerous if used improperly. Also keep in mind that SAFETY requires careful use in accordance with the operating instructions and common sense!

SNAPPER® McDonough, GA., 30253 U.S.A.

COPYRIGHT © 1999
 SNAPPER INC.
 ALL RIGHTS RESERVED

MANUAL No. 4-6359 (REV. 2, 3/13/00)

IMPORTANT SAFETY INSTRUCTIONS

WARNING: This powerful cutting machine is capable of amputating hands and feet and can throw objects that can cause injury and damage! Failure to comply with the following SAFETY instructions could result in serious injury or death to the operator or other persons. The owner of the machine must understand these instructions and must allow only persons who understand these instructions to operate machine. Each person operating the machine must be of sound mind and body and must not be under the influence of any substance, which might impair vision, dexterity or judgment. If you have any questions pertaining to your machine which your dealer cannot answer to your satisfaction, call or write the Customer Service Department at SNAPPER , McDonough, Georgia 30253. Phone: (1-800-935-2967).

PROTECTION FOR CHILDREN

Tragic accidents can occur if the operator is not alert to the presence of children. Children are often attracted to the machine and the mowing activity. Never assume that children will remain where you last saw them.

1. KEEP children out of the mowing area and under the watchful care of a responsible adult.
2. DO NOT allow children in yard when machine is operated (even with the blade OFF).
3. DO NOT allow children or other passengers to ride on machine or on attachments (even with the blade OFF). They may fall and be seriously injured.
4. DO NOT allow pre-teenage children to operate machine.
5. ALLOW only responsible adults & teenagers with mature judgment under close adult supervision to operate machine.
6. BE SURE the area is clear of others before mowing and turn machine OFF if anyone enters the area.
7. DO NOT mow in reverse unless absolutely necessary. LOOK BEHIND and down for small children before and when backing.
8. USE EXTRA CARE when approaching blind corners, shrubs, trees, or other objects that may obscure vision.

PROTECTION AGAINST TIPOVERS

Slopes are a major factor related to loss-of-control and tip-over accidents, which can result in severe injury or death. All slopes require extra CAUTION. If you cannot back up the slope or if you feel uneasy on it, DO NOT mow it. Use extra care with grass catchers or other attachments; these can change the stability of the machine.

1. DO NOT operate machine on slopes exceeding 15 degrees (27% grade).
2. Exercise EXTREME CAUTION on slopes above 10 degrees (18% grade). Turn blade OFF when traveling uphill. Use first speed and avoid sudden or sharp turns.
3. DO NOT mow back and forth across face of slopes. Mow up and down.

PROTECTION AGAINST TIPOVERS

(Continued From Previous Column)

4. AVOID uphill starts. If machine stops going uphill or tires lose traction, turn blade OFF and back slowly down the slope.
5. STAY ALERT for holes and other hidden hazards. Tall grass can hide obstacles. Keep away from ditches, washouts, culverts, fences and protruding objects.
6. KEEP A SAFE DISTANCE (at least 3 feet) away from edge of ditches and other drop offs. The mower could turn over if an edge caves in.
7. Always begin forward motion in the #1 speed position.
8. Use weights or a weighted load carrier in accordance with instructions supplied with a grass catcher. DO NOT operate machine on slopes exceeding 10 degrees (18% grade) when equipped with grass catcher.
9. DO NOT put your foot on the ground to try to stabilize the machine.
10. DO NOT mow on wet grass. Reduced traction could cause sliding.
11. DO NOT mow under any condition where traction, steering or stability is doubtful without first test driving over the terrain with blade OFF.

PREPARATION

1. Read this manual, get to know where all controls are located and practice how to use them before starting for the first time, and at the beginning of each season. Read and follow Warnings and Instructions on engine and machine. Read and follow operator's manual and instructions furnished with attachments.
2. Only mature, responsible persons shall operate the machine and only after proper instruction.
3. Data indicates that operators age 60 and above, are involved in a large percentage of mower-related injuries. These operators should evaluate their ability to operate the mower safely enough to protect themselves and others from serious injury.

IMPORTANT SAFETY INSTRUCTIONS

PREPARATION

(Continued From Previous Page)

4. Handle fuel with extra care. Fuels are flammable and vapors are explosive. Use only an approved fuel container. Never remove fuel cap or add fuel with engine running. Add fuel outdoors only with engine stopped and cool. Clean spilled fuel from machine. **DO NOT** smoke.
5. Practice operation of machine with **BLADE OFF** to learn controls and develop skills.
6. Check the area to be mowed and remove all objects such as toys, wire, rocks, limbs and other objects that could cause injury if thrown by blade or interfere with mowing.
7. Keep people and pets a safe distance from machine.
8. Check shields, deflectors, switches, blade controls and other safety devices frequently for proper operation and location.
9. Make sure all safety decals are clearly legible. Replace if damaged.
10. Protect yourself when mowing and wear safety glasses, long pants and substantial footwear.
11. Know how to **STOP** blade and engine quickly in preparation for emergencies.
12. Use extra care when loading or unloading the machine into a trailer or truck.
13. Check grass catcher components frequently for signs of wear or deterioration and replace as needed to prevent injury from thrown objects going through weak or worn spots.

OPERATION

1. Mount and dismount machine from left side.
2. Start engine from operator's seat, if possible. Make sure blade is **OFF** and parking brake is set.
3. **STOP** blade, **STOP** engine, set parking brake and remove key when leaving machine.
4. **DO NOT** operate machine unless properly seated with feet on feet rests or pedal(s).
5. **STOP BLADE** and **ENGINE** and make sure blade has stopped before removing grass catcher or unclogging mower to prevent loss of fingers or hand.
6. Blade must be **OFF** except when cutting grass. Set blade in highest position when mowing over rough ground.
7. Keep hands and feet away from rotating blade underneath deck. **NEVER** place foot on ground while **BLADE** is **ON** or machine is in motion.
8. Deflector or entire grass catcher must be in place. **NEVER** point discharge at people, passing cars, windows or doors.
9. Slow down before turning.
10. Watch out for traffic when near or crossing roadways.
11. **STOP** engine immediately after striking an obstruction. Inspect machine and repair damage before resuming operation.

OPERATION

(Continued From Previous Column)

12. Mow only in daylight or with good artificial light.
13. Move joystick (if equipped) **SLOWLY** to maintain control during speed and directional changes.
14. Exercise **CAUTION** when pulling loads. Limit loads to those you can safely control and attach loads to hitch plate as specified with **SNAPPER** attachment instructions.

MAINTENANCE

1. Never store machine or fuel container inside where fumes may reach an open flame, spark or pilot light such as in a water heater, furnace, clothes dryer or other gas appliance. Allow engine to cool before storing machine in an enclosure. Store fuel container out of the reach of children in a well ventilated, unoccupied building.
2. Keep engine free of grass, leaves or excess grease to reduce fire hazard and engine overheating.
3. When draining fuel tank, drain fuel into an approved container outdoors and away from open flame.
4. Check brakes frequently; adjust, repair or replace as needed.
5. Keep all bolts, nuts and screws properly tight. Check that all cotter pins are in proper position.
6. Always provide adequate ventilation when running engine indoors. Exhaust gases contain carbon monoxide, an odorless and deadly poison.
7. Disconnect negative (black) cable from battery before performing maintenance or service. Cranking engine could cause injury.
8. Never work under machine without safety blocks.
9. Service engine and make adjustments only when engine is stopped. Remove spark plug wire(s) from spark plug(s) and secure wire(s) away from spark plug(s).
10. **DO NOT** change engine governor speed settings or overspeed engine.
11. Lubricate machine at intervals specified in manual to prevent controls from binding.
12. Mower blades are sharp and can cut. Wrap the blades or wear heavy leather gloves and use **CAUTION** when handling them.
13. **NEVER** test for spark by grounding spark plug next to spark plug hole; spark plug could ignite gas exiting engine.
14. Have machine serviced by an authorized **SNAPPER** dealer at least once a year and have the dealer install any new safety devices.
15. Use only genuine **SNAPPER** replacement parts to assure that original standards are maintained.

TABLE OF CONTENTS

IMPORTANT SAFETY INSTRUCTIONS	2-3
TABLE OF CONTENTS	4
SECTION 1 - FAMILIARIZATION	5
SECTION 2 - OPERATING INSTRUCTIONS	6-9
Pre-start Checklist	6-7
Starting Engine	7
Starting & Stopping Engine, Mower Blades	8
Starting & Stopping Wheel Drive	8
Setting & Releasing Parking Brake	8
Adjusting Cutting Height	9
SECTION 3 - MAINTENANCE INSTRUCTIONS	10-13
Changing Engine Oil.....	10
Checking Mower Blade.....	10
Checking Mower Drive Belt	11
Checking Belt Tension.....	11
After Every 25 Operating Hours	11
Check Mower Components	11
Mower Blade Spindle Lubrication	12
Front Wheel Bearings Lubrication	12
Front Caster Wheel Pivot Shaft Lubrication	12
Parking Brake Pivot Bushing Lubrication	12
Annually (End of Each Season).....	13
Engine	13
Air Filter	13
Oil Filter	13
Engine Oil.....	13
Transaxle.....	13
Fuel Filter	13
Storage - Out of Season.....	13
SECTION 4 - ADJUSTMENTS AND REPAIR	14-21
Neutral Position Adjustments	14
Mower Drive Belt Adjustment	14
Mower Drive Belt Replacement	15
Blade Brake Adjustment.....	15
Mower Blade Adjustment.....	16
Mower Blade Adjustment (Levelness)	17
Mower Deck Adjustment (Levelness).....	18
Mower Deck Timing Rod	18
Wheel Brake Adjustment.....	19
Mower Blade Repair/Replacement.....	19-20
Battery Removal	20
Battery Installation	20
Battery Service & Charging	20
Battery Storage.....	20
Battery Testing.....	21
New Battery Preparation.....	21
TROUBLESHOOTING	22-23
SERVICE SCHEDULE	24
Maintenance/Replacement Parts	24
WARRANTY	25
PRIMARY MAINTENANCE	26-29

Section 1 - FAMILIARIZATION

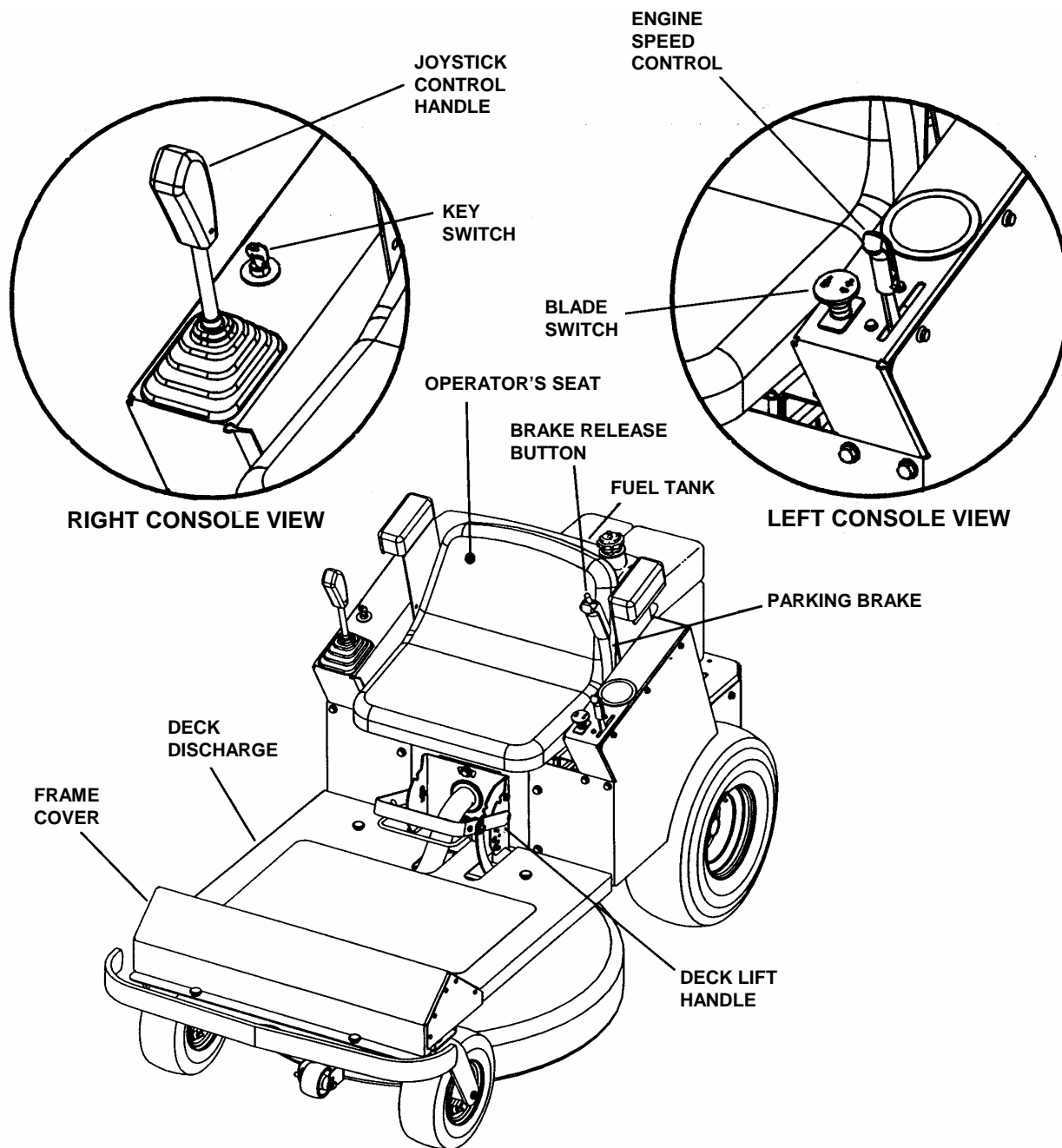

FIGURE 1.1

1.1 INTRODUCTION

This manual has been prepared for the operator's of the SNAPPER YARD CRUISER. Its purpose, aside from recommending standard operating procedures and routine service requirements, is to promote SAFETY through the use of accepted operating practices. Read, Understand and Follow the IMPORTANT SAFETY INSTRUCTIONS on Pages 2 and 3 of this manual and All SAFETY messages on the YARD CRUISER and its attachments before operating. SNAPPER recommends returning the YARD CRUISER to an authorized SNAPPER dealer annually for inspection and addition of any new devices which might upgrade the safety of the mower.

1.2 NOMENCLATURE

The nomenclature drawing above, Figure 1.1, shows the essential parts of the SNAPPER YARD CRUISER. It is recommended that all operator's of this equipment become thoroughly familiar with the controls, components, and operation of this machine before operating. Specific details involving the engine are found in the separate engine owner's manual. Study these manuals before operating and keep both handy for future reference. For the nearest SNAPPER dealer in your area, check the yellow pages under the heading LAWN MOWERS. For engine parts and service, look for the engine manufacturer's dealers under the heading, ENGINES - gasoline.

Section 2 - OPERATING INSTRUCTIONS

2.1 PRE-START CHECK LIST

Make the following checks and perform the service required before each start-up.

2.1.1. Check tires and add or release air as needed to bring pressure to 12 psi in front and 12 psi in rear tires.

2.1.2. Check guards, deflectors and covers to make sure all are in place and securely tightened.

2.1.3. Check engine oil and add oil as needed to bring level up to the FULL mark. Refer to engine owner's manual for oil specifications. See Figure 2.1.

ENGINE OIL DIPSTICK

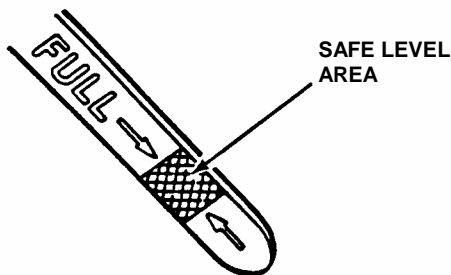

FIGURE 2.1

2.1.4. Check Blade switch to insure it works freely. Switch is pulled "OUT" into the "ON" position for blade engagement or pushed back "IN" into the "OFF" position for blade disengagement. See Figure 2.2. **IMPORTANT:** Disengagement stops the blades rotation.

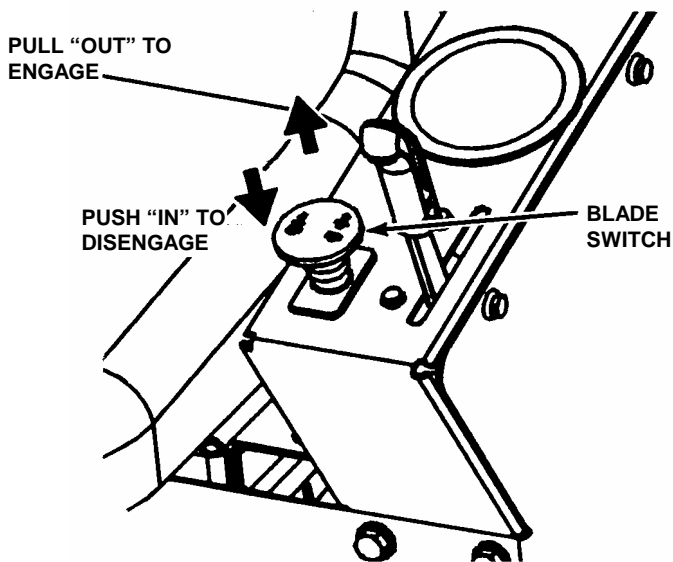

FIGURE 2.2

2.1.5. Clean exterior surfaces of cutting deck and engine of any accumulation of dirt, grass, oil, etc. Keep engine air intake screen and cooling fins clear at all times.

2.1.6. Add fuel to tank of the YARD CRUISER outside where fumes can safely dissipate. Make sure fuel filler cap is tight and vent is open after refueling. See Figure 2.3. Refer to engine owner's manual for fuel specifications.

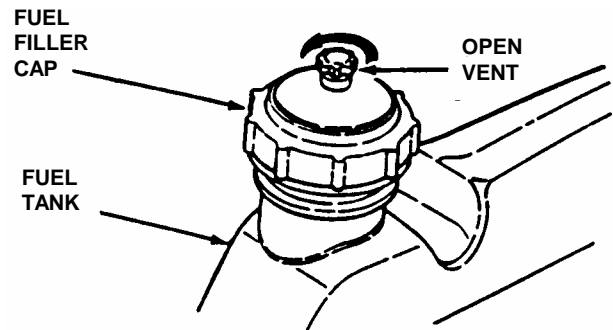

FIGURE 2.3

IMPORTANT: This YARD CRUISER is equipped with hydrostatic drive. The forward, rearward and steering movement of the machine is controlled by a joystick lever. Joystick operations should be performed only from the operator's position in the seat. A small movement of the joystick can cause the machine to move instantly. Move joystick very carefully and slowly.

1. Always move the joystick to the center position to "STOP" machine. **IMPORTANT:** To stop machine always return the joystick with hand assistance to the neutral position. Always engage parking brake when leaving operator's seat.
2. Move the joystick forward to propel the machine forward.
3. Move the joystick rearward to propel the machine backward.
4. Move the joystick to the right to rotate the front of the machine in circular motion to the right, as in turning around to go in a different direction.
5. Move the joystick to the left to rotate the front of the machine in circular motion to the left, as in turning around to go in a different direction.

Section 2 - OPERATING INSTRUCTIONS

IMPORTANT: To roll the machine without the engine running, pressure within the hydraulic pumps must be released. Tilt seat up and move control lever down to release pressure. **NOTE: Control lever must be in the "UP" position to drive machine.** See Figure 2.4.

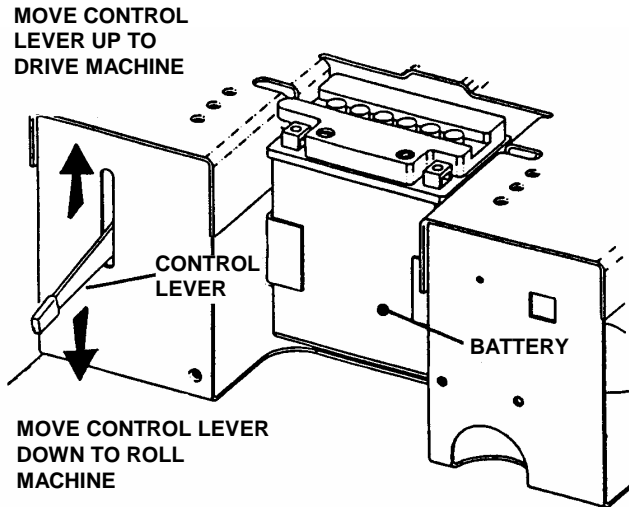

FIGURE 2.4

2.2 STARTING & OPERATION

2.2.1. ENGINE (ELECTRIC START)

When the ignition key is turned to "START", the engine will not turn over unless the parking brake is engaged and the blade switch is in the "OFF" position!

2.2.2. OPERATION

Be seated on the YARD CRUISER before attempting to start the engine with the key switch.

1. Make certain the blade switch is in the "OFF" position.
2. Make certain the joystick lever is in the neutral (N) position as shown in Figure 2.5.

IMPORTANT: The joystick lever has to be manually moved to propel machine. Always return the joystick with hand assistance to the neutral position to stop machine. The machine will only crank or start if parking brake lever is engaged and the blade switch is in the "OFF" position.

3. Make certain the parking brake lever is engaged. See Figure 2.6.
4. Move choke/engine speed control to the choke position to start a cold engine. See Figure 2.6.
5. Turn key to the start position until engine starts. See Figure 2.5.
6. After engine starts, move choke/engine speed control away from the choke position to the (Rabbit) "Fast" position.
7. Allow a brief warm-up until engine runs smooth.

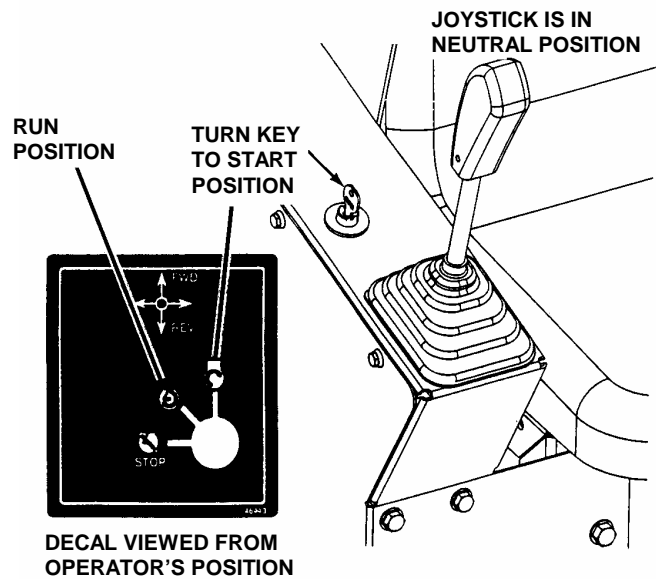

FIGURE 2.5

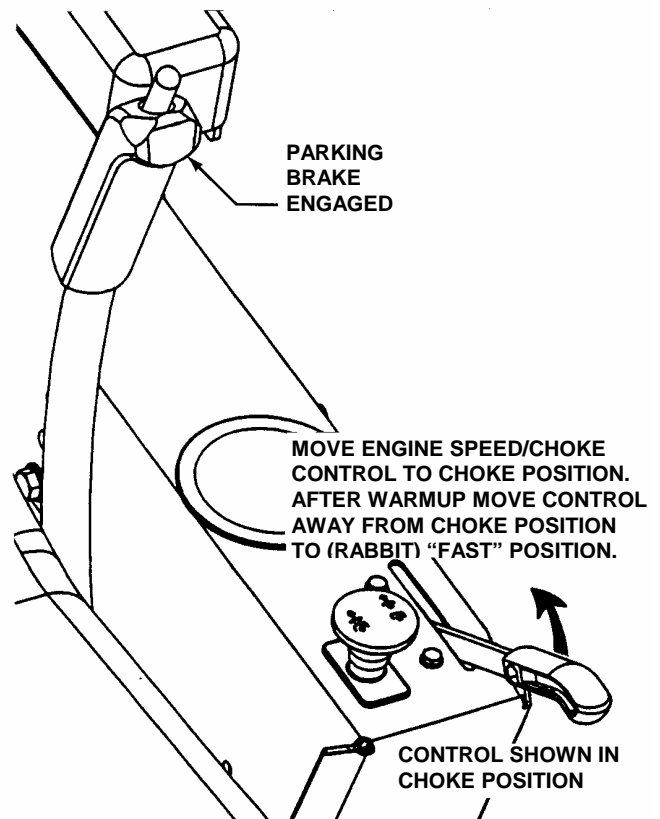

FIGURE 2.6

Section 2 - OPERATING INSTRUCTIONS

2.2.3. MOWER BLADE

1. With engine running, move engine speed control to the Rabbit or "fast" position.
2. Pull the blade switch out into the "ON" position to engage the mower blades. See Figure 2.7.

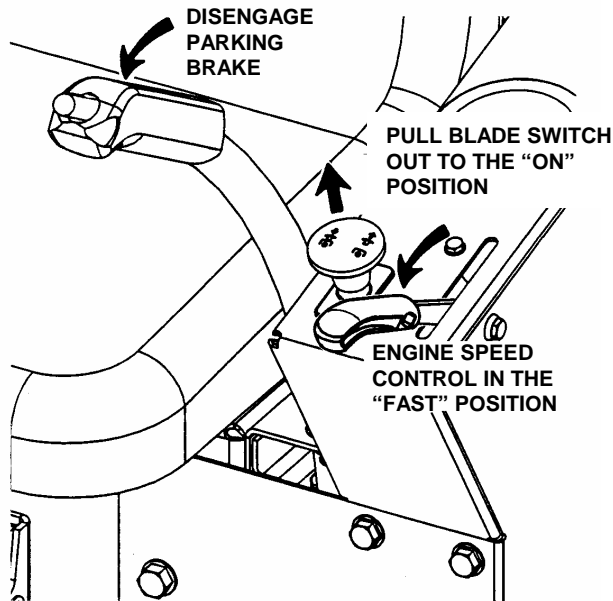

FIGURE 2.7

3. Release the parking brake. See Figure 2.7.
4. Move joystick carefully in the desired direction to propel the machine. A small movement of the joystick can cause the machine to move instantly. Move joystick carefully and slowly.

2.3 STOPPING

2.3.1. ENGINE

1. Stop engine by turning key to the "OFF" position. See Figure 2.8.

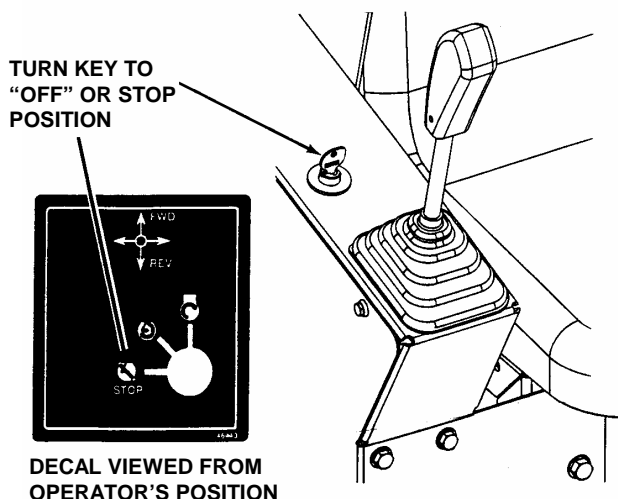

FIGURE 2.8

WARNING

Before leaving the Riding Mower, push blade switch in to the "OFF" position to STOP blade, move joystick to neutral and engage the parking brake. Turn key switch to the OFF position. Remove key.

2.3.2. WHEEL DRIVE

1. Stop motion of riding mower by moving joystick to neutral (N) position. Refer to Figure 2.8.

2.3.3. MOWER BLADE

1. Push the blade switch in to "OFF" position to disengage or stop the mower blades. Refer to Figure 2.7.

WARNING

Once blades are disengaged, they should come to a complete stop in 5 seconds. If the blades continue to rotate after 5 seconds, the electric clutch should be checked. Replacement of electric clutch may be necessary. DO NOT continue to operate mower if blades fail to stop in 5 seconds.

2.3.4. PARKING BRAKE

1. Manually position joystick in the neutral position.
2. Engage parking brake by pushing button at the top of lever and then pulling the parking brake lever slowly back to the "ON" position.
3. Release parking brake by pushing button at the top of lever and moving brake lever forward to the "OFF" position. Refer Figure. 2.7.

Section 2 - OPERATING INSTRUCTIONS

2.3.5. CUTTING HEIGHT ADJUSTMENT

This machine has seven different cutting height positions. **IMPORTANT:** When positioning the cutting deck into a higher cutting position, pull up on the deck lift handle only, it is not necessary to pull up on the release lever at the same time. Use the release lever when moving deck cutting height to a lower cutting position.

1. Grasp both handles together to disengage latch.
 2. Raise or lower handles to desired height.
 3. Release lower handle to engage latch.
- See Figure 2.9.

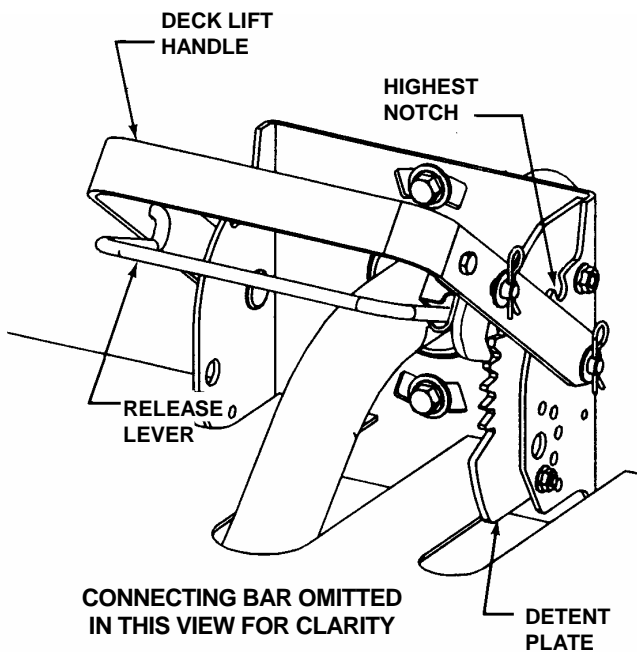

FIGURE 2.9

Section 3 - MAINTENANCE

3.1 INTRODUCTION

To retain the quality of the YARD CRUISER, use genuine SNAPPER replacement parts only. Contact a local SNAPPER dealer for parts and service assistance. For the correct part or information for a particular mower, always mention the model and serial number.

3.2 SERVICE - AFTER FIRST 5 HOURS

WARNING
Before attempting any adjustments or repairs, STOP the engine, remove the key, remove the spark plug wire(s) from the spark plug(s) and secure wire(s) away from plug(s).

3.2.1. CHANGE ENGINE OIL

1. Place bricks or wooden blocks under the front wheels to lower rear of engine.
2. Place a 4 quart minimum capacity container under the end of the oil drain.
3. Loosen or remove oil fill cap on engine.
4. Install the drain hose (Supplied in hardware bag) onto drain plug nipple and place hose into drain container.
5. Rotate drain plug counter clockwise and pull out to open and allow oil to drain out. See Figure 3.1.

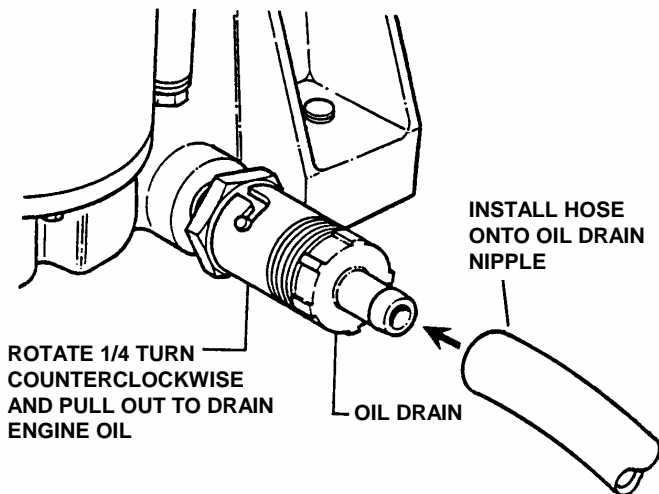

FIGURE 3.1

6. After all the oil has drained, close the drain by pushing in and rotating clockwise to close. Wipe up any oil that may have spilled. Dispose of drained oil properly. See Figure 3.1.
7. Change oil filter at every oil change. Refer to your engine owner's manual for service instructions.
8. Fill engine crankcase with new oil. Refer to your engine owner's manual for oil specifications.

3.2.2. CHECK MOWER BLADE

1. Make sure fuel cap is on tight. Turn fuel shut off valve (If equipped) to the "CLOSED" position. Start engine and allow it to run until engine runs out of fuel. Close vent on fuel filler cap. See Figure 2.3, Page 6.
2. Apply parking brake.
3. Turn key to "OFF" position and remove key from ignition switch.

WARNING
Wear heavy leather gloves when handling or working around cutting blades. Blades are extremely sharp and can cause severe injury.

4. Carefully stand YARD CRUISER on rear bumper. It may be necessary to have help to stand unit up.
5. Check torque of blade mounting bolts. Torque to:
33" Deck - 30 to 40 ft. lbs.
38" Deck - 80 to 90 ft. lbs. See Figure 3.2.
6. Check blade for sharpness, wear and damage. See Section on BLADE WEAR LIMITS.

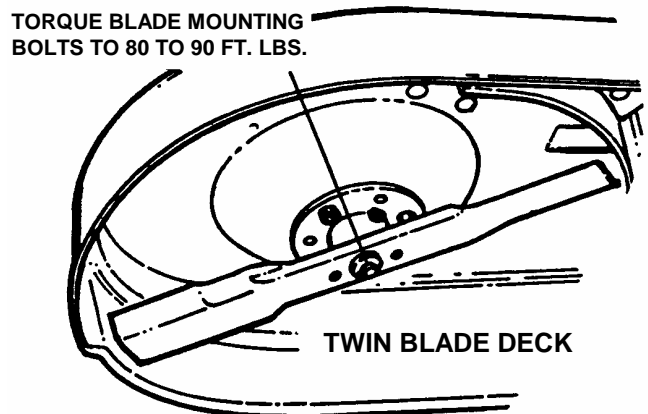
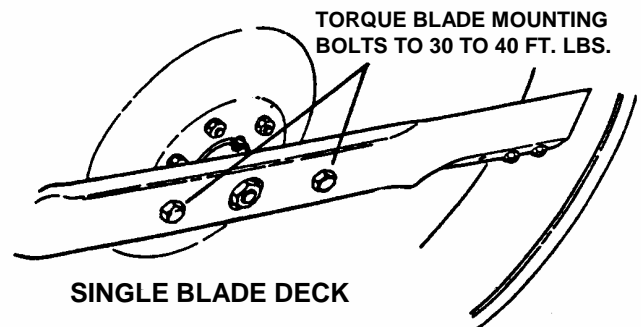

FIGURE 3.2

7. Check blade for straightness.

WARNING
Never use a cutting blade that shows signs of excessive wear or damage. Refer to Section on MOWER BLADE REPAIR/REPLACEMENT for proper blade inspection and service procedures.

Section 3 - MAINTENANCE

3.2.3. CHECK MOWER DRIVE BELT

1. Footrest Removal

- Squeeze the deck lift handle and the release lever and lift the deck lift handle until it locks in the top notch which is the high cut/transport position.
- Remove retaining knobs located at the corners of footrest. Remove footrest. See Figure 3.3.
- Check mower belt. If belt is frayed, slit, severed or belt strands exposed, replace belt before operating mower.
- Reinstall footrest cover and reinstall knobs and tighten securely.

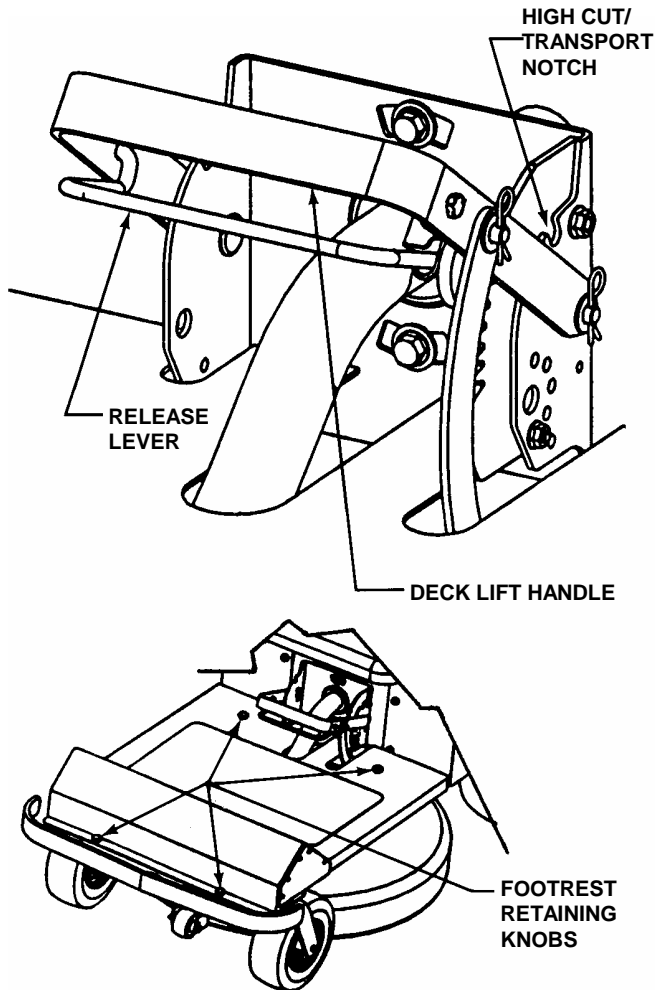

FIGURE 3.3

2. Checking Mower Belt Tension

The idler and spring provide proper belt tension and require no adjustment. If belt is frayed, slit, severed or belt strands exposed, replace belt before operating mower.

3.2.4. CHECK TRANSAXLE DRIVE BELTS

1. Checking Transaxle Belt Tension

The transaxle drive belts require no adjustment. If belts are frayed, slit, severed or belt strands exposed, replace belt before operating mower.

3.3 AFTER EVERY 25 OPERATING HOURS

3.3.1. ENGINE

1. Engine Cooling System

The engine cooling system consists of an engine shroud and engine fins. These should be kept clean and free of debris as needed or cleaned.

2. Engine Oil

Change engine oil. See Section on CHANGE ENGINE OIL. Refer to engine owner's manual for oil specifications.

3. Oil Filter

Change engine oil filter. Refer to engine owner's manual for filter specifications.

4. Air Filter

Refer to engine owner's manual for service instructions.

5. Fuel Filter

Refer to engine owner's manual for service instructions.

3.3.2. MOWER COMPONENTS

1. Mower Drive Belt

Check belt for proper tension. No adjustment required. Replace belt as needed.

2. Mower Blade

Check blade for sharpness, wear, damage, and torque. See the section on Mower Blade Replacement/Repair.

3. Mower Deck Levelness

Check mower deck for proper levelness. Adjust as required. See section on Mower Deck Adjustment - Levelness.

WARNING

Lifting or lowering the machine onto or down from the rear bumper unassisted can cause severe injury. Always have assistance from another person when supporting the weight of machine.

4. Cleaning Mower Deck

- Make sure fuel cap is on tight. Turn fuel shut off valve (If equipped) to the "CLOSED" position. Start engine and allow it to run until engine runs out of fuel. Close vent on fuel filler cap. See Figure 2.3, Page 6.
- Remove key from ignition switch.
- Remove spark plug wire(s) and secure away from spark plug(s).
- Carefully stand YARD CRUISER on rear bumper.
- Clean underside of mower deck, removing all accumulation of grass clippings and debris.
- Lower YARD CRUISER to ground. Clean top of deck, removing all grass clippings and debris.

Section 3 - MAINTENANCE

3.3.2. MOWER COMPONENTS (Continued)

5. Mower Blade Spindle - Lubrication

- a. Lubricate spindle bearings with three shots of general purpose grease from grease gun. See Figure 3.4.

UNDERSIDE VIEW OF 33" DECK

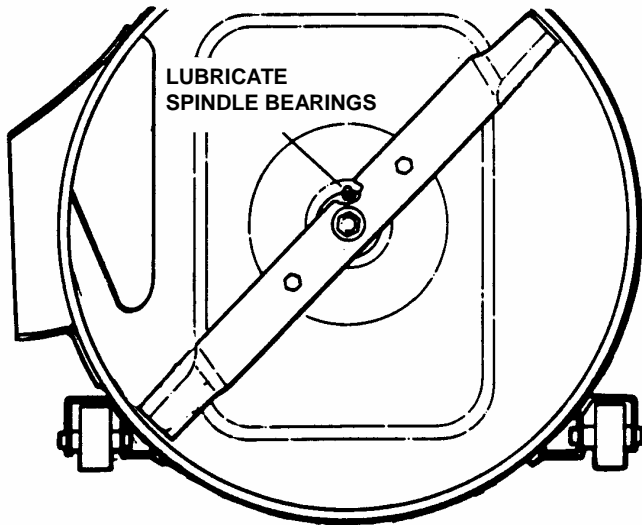

FIGURE 3.4

6. Mower Deck Linkage - Lubrication

Lubricate all mower deck linkage pivot points with a light coat of motor oil.

3.3.3. YARD CRUISER - LUBRICATION

1. Front Wheel Bearings

Lubricate front wheel bearings with five shots of general purpose grease from grease gun. See Figure 3.5.

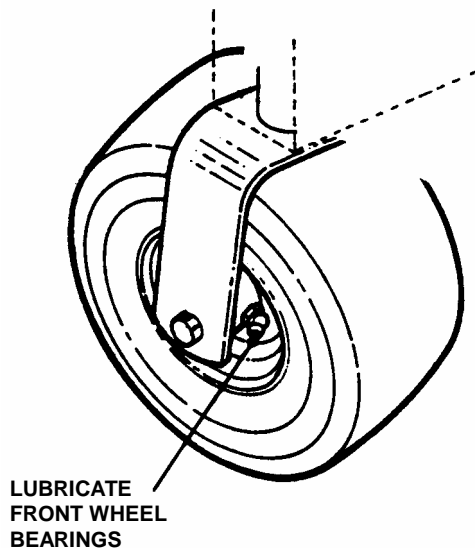

FIGURE 3.5

2. Front Caster Wheel Pivot Shaft

The front frame cover will not have to be removed to lubricate the pivot shaft. The access hole is at the rear of the front structure underneath frame cover.

- a. The pivot shaft grease fitting can be accessed through a hole at the rear of the front structure. Lubricate pivot shaft with three shots of general purpose grease from grease gun. See Figure 3.6.

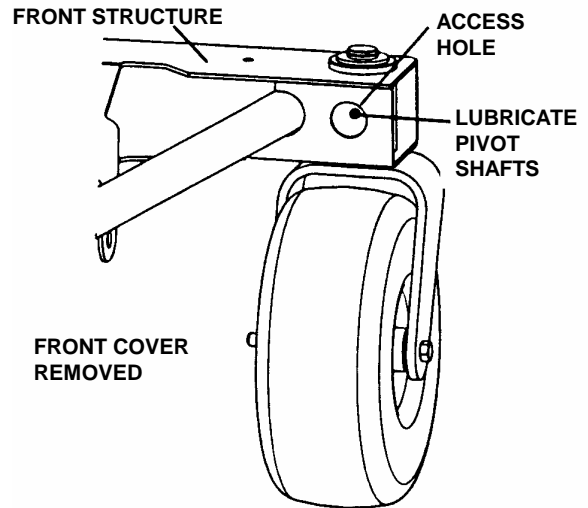

FIGURE 3.6

3. Parking Brake Pivot Bushings

- a. Make sure fuel cap is on tight. Turn fuel shut off valve (if equipped) to the "CLOSED" position. Start engine and allow it to run until engine runs out of fuel. Close vent on fuel filler cap.
- b. Remove key from ignition switch.
- c. Remove spark plug wire(s) and secure away from spark plug(s).
- d. Carefully stand YARD CRUISER on rear bumper.
- e. Lubricate both pivot bushings with three shots general purpose grease from grease gun. See Figure 3.7.

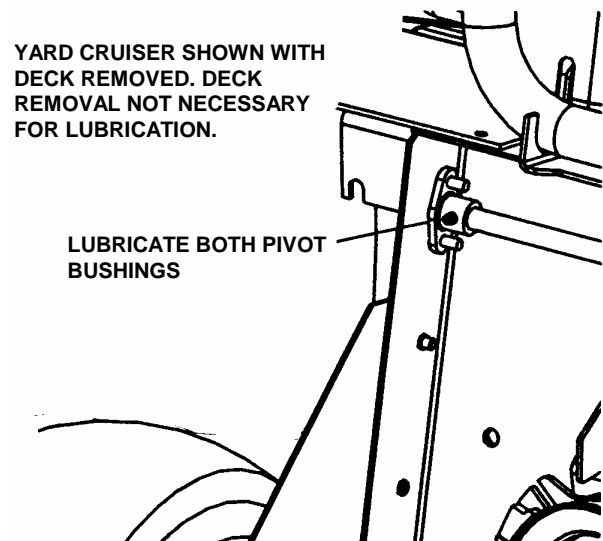

FIGURE 3.7

Section 3 - MAINTENANCE

3.4 ANNUALLY (END OF EACH SEASON)

Perform all maintenance as described in the maintenance schedule.

3.4.1. Engine

Service engine according to engine owner's manual.

3.4.2. Air Filter

Refer to engine owner's manual for service instructions.

3.4.3. Oil Filter

Refer to engine owner's manual for service instructions.

3.4.4. Engine Oil

Refer to engine owner's manual for service instructions.

3.4.5. Transaxle

IMPORTANT: DO NOT try to open reservoir cap at any time. The transaxle is maintenance free. The transaxle does not require any fluid or any service. If there is any problem: leakage, malfunction or etc. return the Yard Cruiser immediately to the nearest authorized Snapper dealer for service.

3.4.6. Fuel Filter

Service fuel filter as instructed below. Turn key to "OFF" position. Engine MUST be stopped and MUST be cold before removing filter. Turn fuel shut off valve (If equipped) to the "CLOSED" position or perform filter change when fuel tank and fuel line are empty.

1. Remove hose clamps from fuel filter.
2. Remove fuel lines from filter. Discard filter.
3. Install new fuel filter. Reinstall hose clamps. See Figure 3.8.

3.5 STORAGE (OUT OF SEASON)

If desired, the YARD CRUISER can be stored on the rear bumper. Perform the following procedures to insure the YARD CRUISER will operate properly when taken out of storage.

1. Thoroughly clean the YARD CRUISER by removing all grass clippings and debris.
2. Perform maintenance and lubrication as described in the previous sections.
3. Drain fuel from fuel tank.
4. Start engine and allow it to run until engine runs out of fuel. This allows the carburetor and fuel system to remain clean during storage.
5. Remove battery. See Section on Battery Removal and Storage.
6. Close vent on fuel filler cap. Remove key.
7. Carefully stand YARD CRUISER on rear bumper in desired location for storage.

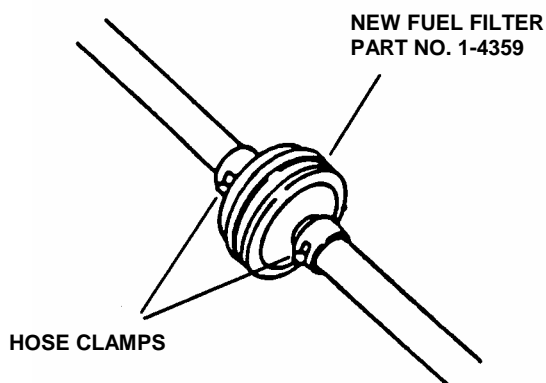

FIGURE 3.8

Section 4 - ADJUSTMENTS & REPAIR

WARNING

Before attempting any adjustments or repairs, STOP the engine, remove the key, remove the spark plug wire(s) from the spark plug(s) and secure wire(s) away from plug(s).

4.1 NEUTRAL POSITION ADJUSTMENTS

The joystick controls the movement and stopping of the unit. Move the joystick to the center or neutral position to stop mower. **IMPORTANT:** Always return the joystick with hand assistance to the neutral position. If mower does not come to a complete stop or has any movement when joystick is moved to the neutral position, adjustment must be made. It is recommended that these adjustments be made by an authorized SNAPPER dealer. But, adjust joystick cables as follows after removing fenders:

1. If mower tracks to the right, loosen bottom nut first on the right cable. Turn top nut clockwise in a 1/8 increment then retighten lower nut to secure cable. Check tracking of mower. Repeat this adjustment if necessary. See Figure 4.1.
2. If mower tracks to the left, loosen bottom nut first on the left cable. Turn top nut clockwise in a 1/8 increment then retighten lower nut to secure cable. Check tracking of mower. Repeat this adjustment if necessary. See Figure 4.1.

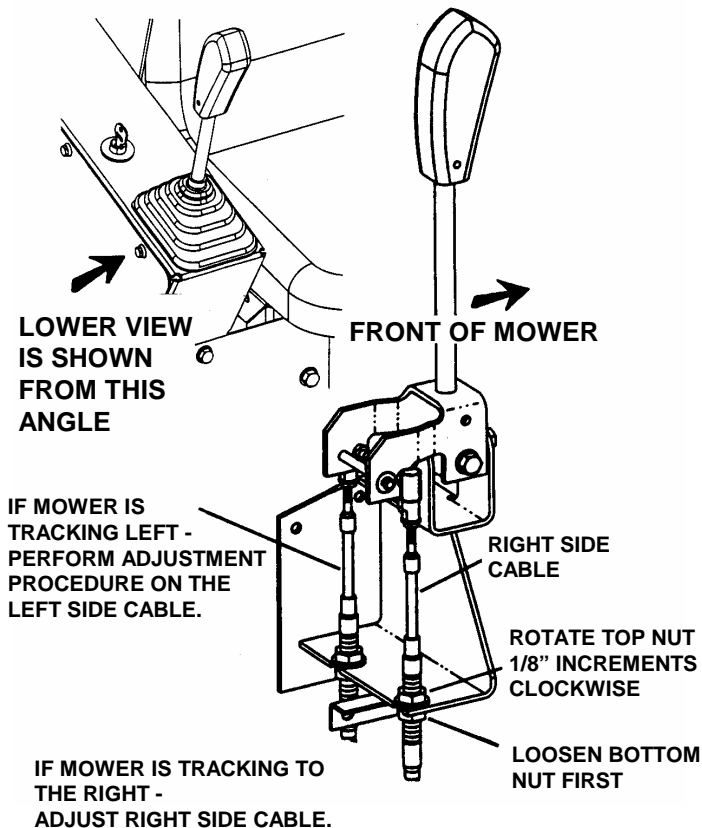

FIGURE 4.1

4.2 ENGINE ADJUSTMENTS & REPAIR

Refer to the engine owner's manual for those adjustments and/or repairs that can be made by the owner.

4.3 MOWER DECK & COMPONENT ADJUSTMENTS

The following mower deck and component adjustments and repairs can be made by the owner. However, if there is difficulty in achieving these adjustments and repairs, it is recommended that these repairs be made by an authorized SNAPPER dealer.

4.3.1. MOWER DRIVE BELT ADJUSTMENT

The 33" and 38" mower deck drive belts do not require any adjustment. If the belt does not drive blade properly, replace belt as needed. See Section on Belt Replacement. Belt routing shown on this page. See Figure 4.2.

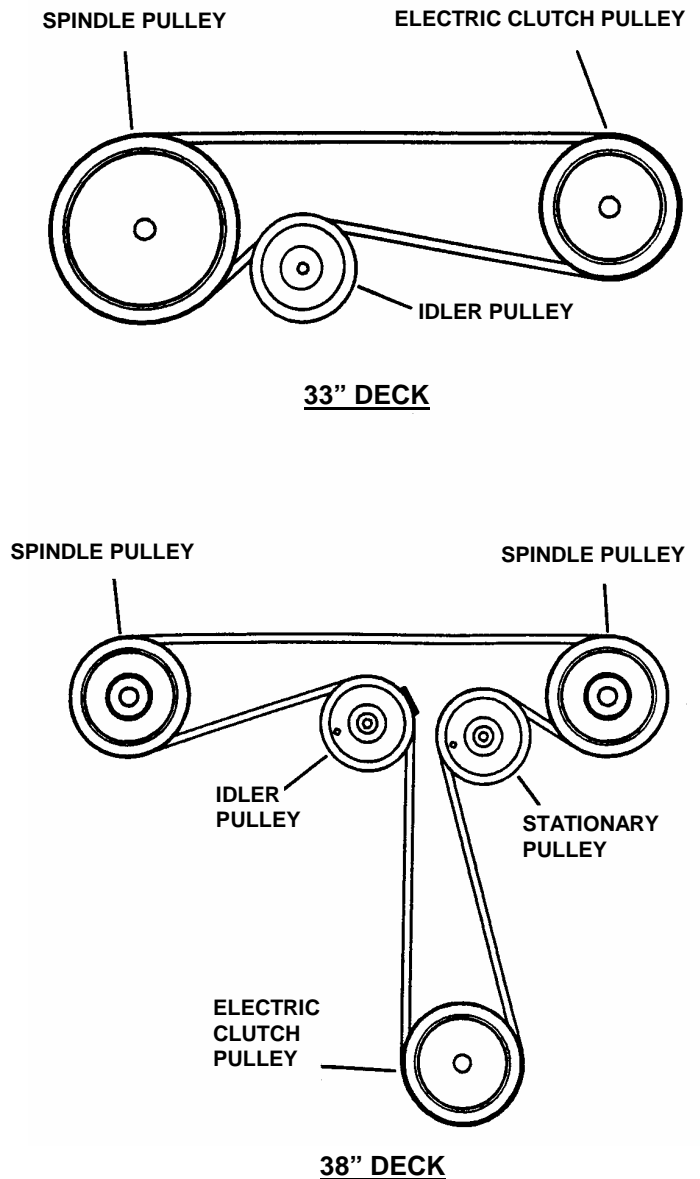

FIGURE 4.2

Section 4 - ADJUSTMENTS & REPAIR

4.3.2. MOWER DRIVE BELT REPLACEMENT

Inspect mower drive belt. Replace belt if signs of excessive wear and/or damage are present.

WARNING

Before attempting any adjustments or repairs, STOP the engine, remove the key, remove the spark plug wire(s) from the spark plug(s) and secure wire(s) away from plug(s).

4.3.3. BELT REMOVAL

1. Remove foot rest. Refer to Section 3.2.3. - Foot Rest Removal.
2. Remove old belt.

4.3.4. BELT REPLACEMENT

1. Route new belt around electric clutch pulley. See Figure 4.3.

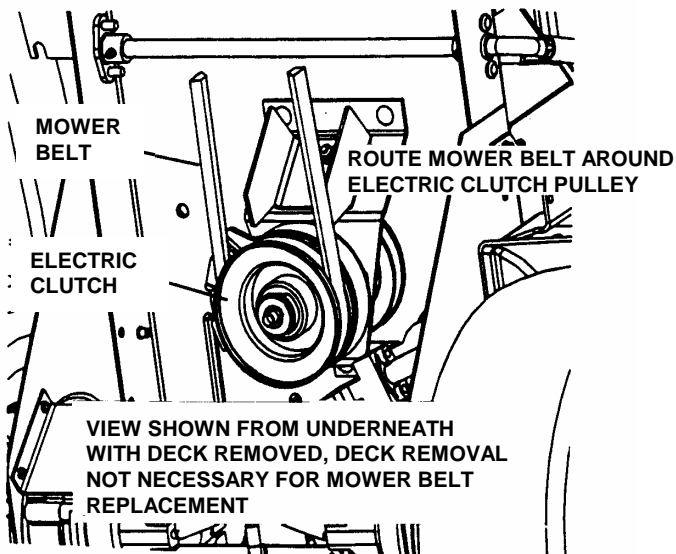

FIGURE 4.3

2. Route belt around stationary idler.
3. Remove spring that is connected to idler pulley. Loosen nut and bolt that secures idler pulley to idler arm. Route belt between belt guide and idler pulley.
4. Route belt onto spindle pulley. Make sure belt is inside spindle pulley belt guide.
5. Reinstall idler pulley spring. See Figure 4.4. NOTE: The idler belt guide should be positioned so the locator tab fits into the corresponding hole found on the idler arm. See Figure 4.4. Tighten bolt securely.
6. Reinstall front frame cover.

BELT REPLACEMENTS	
Engine to Hydro Pumps (All Models)	Part No. 4-1823
Engine to Electric Clutch (All Models)	Part No. 2-9117
Electric Clutch to Mower (33" Decks)	Part No. 3-5389
Electric Clutch to Mower (38" Decks)	Part No. 2-9308

IDLER ARM AND BELT GUIDE DETAIL

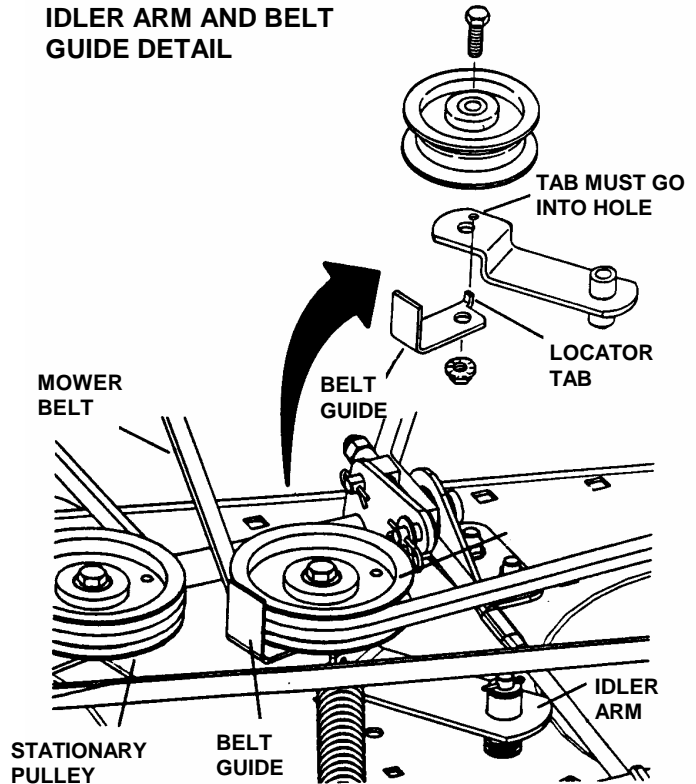

FIGURE 4.4

4.3.5. BLADE BRAKE

The blade switch engages the electric clutch when pulled out to the "ON" position. When the blade switch is in the "ON" position the cutting blade(s) are engaged. The blade switch disengages the electric clutch when the blade switch is pushed in to the "OFF" position. When the blade switch is in the "OFF" position the cutting blade(s) are disengaged. The electric clutch is non-adjustable. The blade(s) should stop rotation in 5 seconds. If the electric clutch fails to stop the blade(s) rotation in 5 seconds, contact an authorized SNAPPER dealer to repair or replace.

Section 4 - ADJUSTMENTS & REPAIR

WARNING

Before attempting any adjustments or repairs, **STOP** the engine, remove the key, remove the spark plug wire(s) from the spark plug(s) and secure wire(s) away from plug(s).

4.3.6. ADJUSTING MOWER BLADE

The straightness of the mower blade(s) is essential for smooth, even mowing. Adjust blade straightness as follows. **NOTE: Follow Steps 1 thru 4 for all deck sizes.**

1. Make sure fuel cap is on tight. Turn fuel shut off valve (If equipped) to the "CLOSED" position. Start engine and allow it to run until engine runs out of fuel. Close vent on fuel filler cap. See Figure 2.3, Page 6.
2. Remove key from ignition switch.
3. Remove spark plug wire(s) and secure away from spark plug(s).
4. Carefully stand YARD CRUISER on rear bumper.

(Adjusting the 33" Deck Blade)

5. Select a point on the deck and mark for reference.
6. Mark blade tips as "A" and "B".
7. Rotate blade until blade tip "A" is at deck reference mark.
8. Measure the distance between deck lip and blade tip. **NOTE: On 33" decks, the measurement between the blade tip and deck lip should be 3/8".** See Figure 4.5.
9. Repeat step 8 with blade tip "B".
10. If measurement between blade tips and deck are different and there is more than 1/16" difference between blade tip measurements, adjust blade as follows:
 - a. Loosen jam-nuts on the ends of blade bar.
 - b. Adjust jack screws "IN" or "OUT" until blade tip measurements are within 1/16" of each other and blade tips are 3/8" away from deck lip. See Figure 4.6.
 - c. Retighten jam-nuts securely.

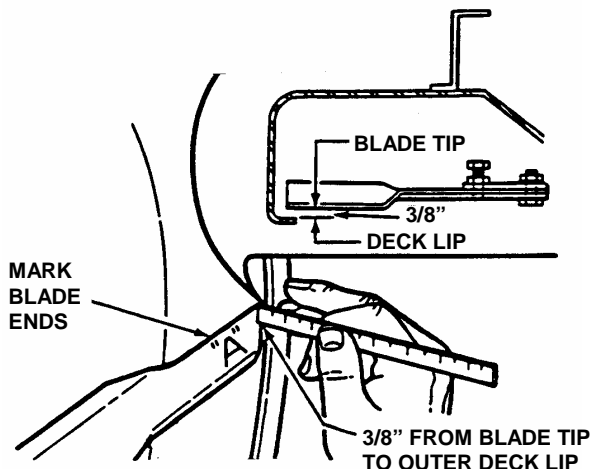

FIGURE 4.5

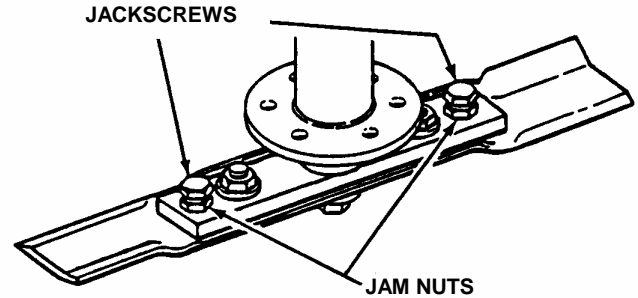

FIGURE 4.6

(Adjusting The 38" Deck Blades)

NOTE: Follow Steps 1 thru 4 for all deck sizes.

11. Mark each blade's tips as "A" and "B". See Figure 4.7.
12. Rotate both blades until blade cutting edges "A" are at their closest point.
13. Measure the distance between both "A" blade cutting edges and deck. See Figure 4.7.

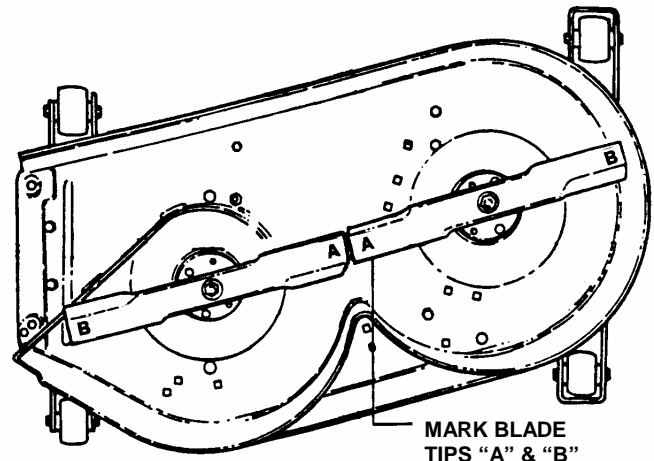

FIGURE 4.7

14. Rotate blade until blade cutting edges "B" are together. See Figure 4.8.
15. If the measurements differ by more than 1/6" between either set of blade tips, one or both blades are bent and must be replaced with new blades.

MEASURE FROM BLADE TIPS TO DECK

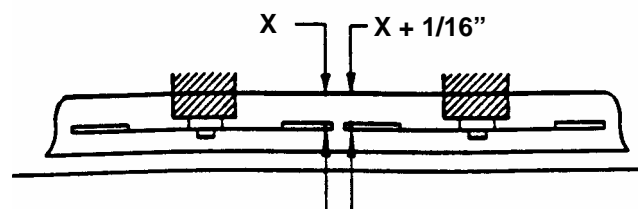

FIGURE 4.8

Section 4 - ADJUSTMENTS & REPAIR

WARNING
Before attempting any adjustments or repairs, STOP the engine, remove the key, remove the spark plug wire(s) from the spark plug(s) and secure wire(s) away from plug(s).

4.3.7. MOWER DECK ADJUSTMENT (LEVELNESS) Side-To-Side (33" & 38" Decks)

Before making deck leveling adjustments, check the tire pressure. Check tires and add or release air as needed to bring pressure to 12 psi in front and 12 psi in rear tires. If tires are properly inflated and mowing is still uneven, adjust side-to-side deck levelness as follows:

1. Place YARD CRUISER on a smooth level surface.
2. Turn engine off and remove key, remove spark plug wire(s) from spark plug(s) and secure wire(s) away from plug(s).
3. Place a piece of angle iron, pipe, or similar object under center of deck at the rear.
4. Remove rear hanger chains and allow center, rear of deck to rest on angle iron.
5. Measure the distance from blade tips to floor. If the measurement is within 1/8" from side-to-side, the deck levelness is satisfactory. If the difference from side-to-side is greater than 1/8", continue to the next page for adjustment. See Figure 4.9.

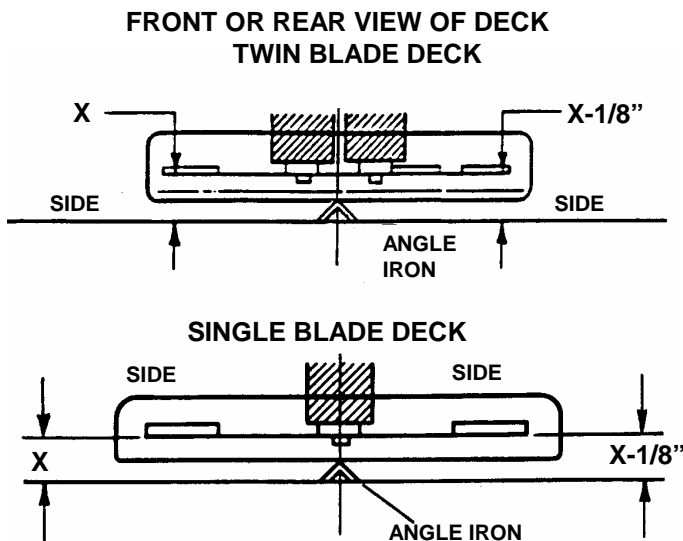

FIGURE 4.9

6. Loosen the shoulder bolt that retains the eccentric.
7. Turn eccentric "UP" or "DOWN" as required until blade tips are within 1/8" of the same distance from the floor. See Figure 4.10.
8. Tighten shoulder bolt loosened in Step "f".
9. Readjust rear hanger chain pivots to align with holes in support brackets.
10. Reconnect hanger chains, remove angle iron, pipe, etc. and recheck side to side level. Adjust either chain as needed to result in blade tips being within 1/8" of the same distance from the floor.
11. Proceed to check front to rear deck pitch.

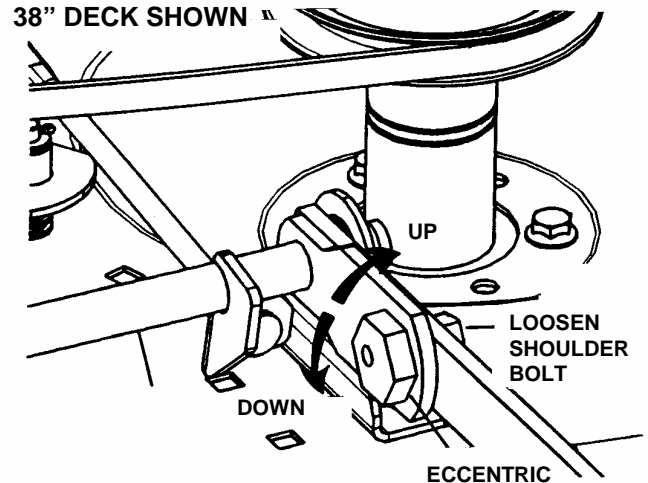

FIGURE 4.10

Section 4 - ADJUSTMENTS & REPAIR

WARNING
 Before attempting any adjustments or repairs, STOP the engine, remove the key, remove the spark plug wire(s) from the spark plug(s) and secure wire(s) away from plug(s).

4.3.8. MOWER DECK ADJUSTMENT (LEVELNESS) Front to Rear Deck Pitch (33" Deck)

With the YARD CRUISER on a smooth, level surface, rotate blade until blade tips are at front and rear of deck. Measure the distance from blade tips to floor. The distance should be the same, or the rear 1/4" lower than the front. If the rear blade tip is higher or is more than 1/4" lower than the front, proceed with adjustment.

1. Remove rear hanger chains.
2. Turn each hanger pivot the same number of rotations on the eye-bolt to raise or lower the rear of the deck. See Figure 4.11.
3. Reinstall rear hanger chains and measure blade tips again.
4. Repeat steps "a" through "c" until proper levelness is obtained.

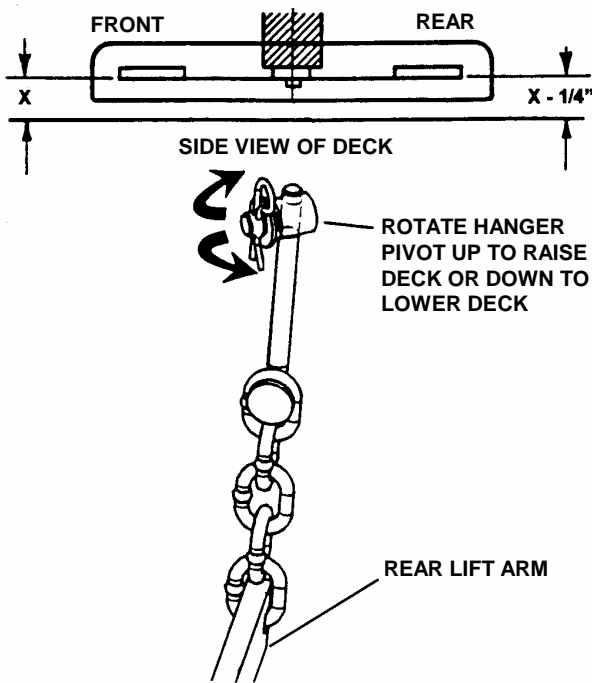

FIGURE 4.11

Front to Rear Deck Pitch (38" Decks)

With the YARD CRUISER on a smooth, level surface, rotate blades until blade tips are at front and rear of deck. Measure the distance from blade tips to floor. The distance should be the same, or the rear 1/4" higher than the front. If the rear blade tip is lower or is more than 1/4" higher than the front, proceed with adjustment.

1. Remove rear hanger chains.
2. Turn each hanger pivot the same number of rotations on the eye-bolt to raise or lower the rear of the deck. See Figure 4.12.
3. Reinstall rear hanger chains and measure blade tips again.
4. Repeat steps "a" through "c" until proper levelness is obtained.

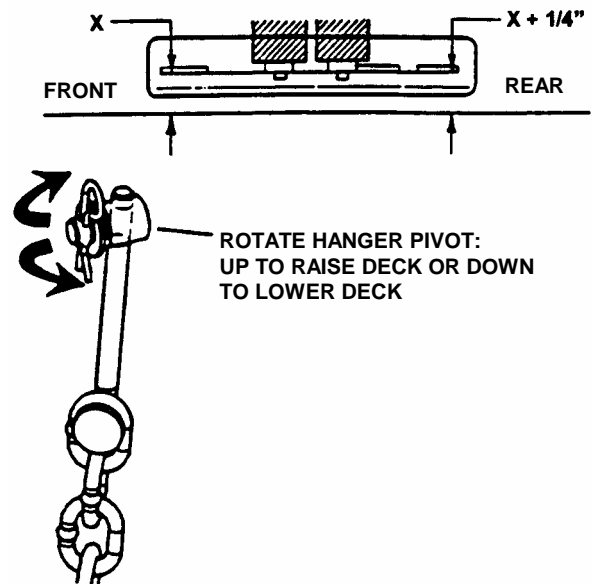

FIGURE 4.12

4.3.9. MOWER DECK TIMING ROD

The mower deck timing rod is pre-adjusted at the factory. It is set to maintain the deck in the same attitude through all heights of cut. If the timing rod requires adjustment, contact an authorized SNAPPER dealer for service. See Figure 4.13.

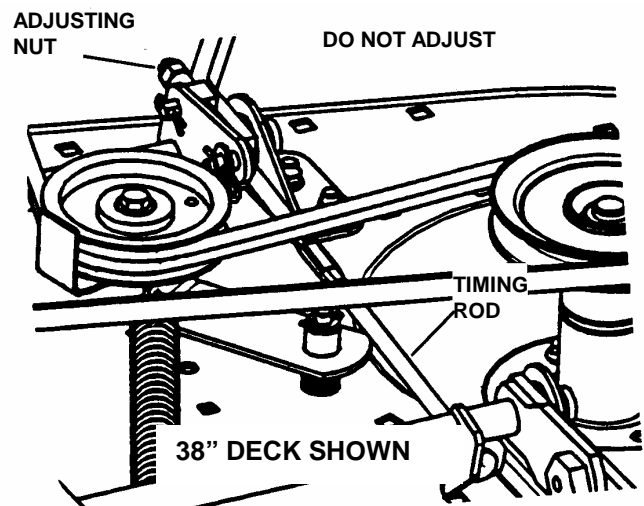

FIGURE 4.13

Section 4 - ADJUSTMENTS & REPAIR

WARNING

Before attempting any adjustments or repairs, STOP the engine, remove the key, remove the spark plug wire(s) from the spark plug(s) and secure wire(s) away from plug(s). Never use a cutting blade that shows signs of excessive wear or damage on the YARD CRUISER. Refer to Figure 4.14.

4.3.10. WHEEL BRAKE ADJUSTMENT

Adjust the wheel brake if wheels turn when parking brake is engaged. Adjust the wheel brake by turning wheel brake adjusting nut clockwise to increase braking action or counter clockwise to decrease braking action. See Figure 4.14.

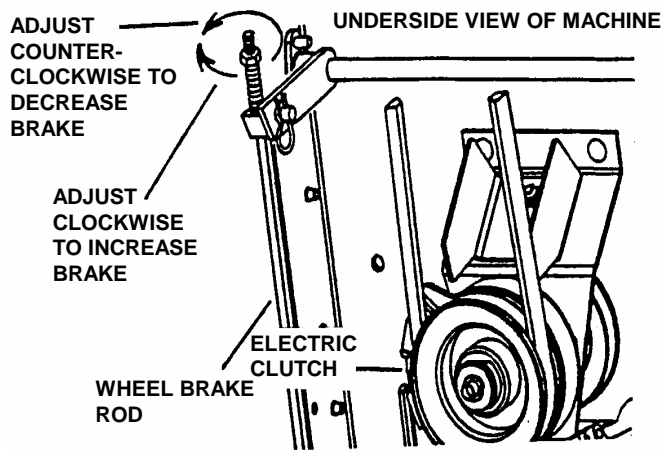

FIGURE 4.14

4.4 MOWER BLADE REPAIR/REPLACEMENT

4.4.1. BLADE WEAR LIMITS

1. Inspect blade frequently for signs of excessive wear or damage. See Figure 4.15.

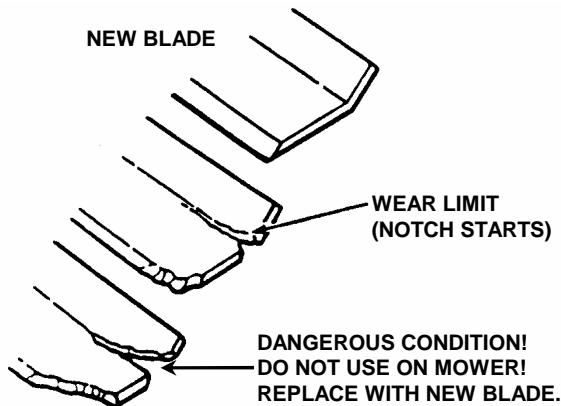

FIGURE 4.15

4.4.2. BLADE SHARPENING

1. Make sure fuel cap is on tight. Turn fuel shut off valve (If equipped) to the "CLOSED" position. Start engine and allow it to run until engine runs out of fuel. Close vent on fuel filler cap. See Figure 2.3, Page 6.
2. Remove key from ignition switch.
3. Remove spark plug wire(s) and secure away from spark plug(s).
4. Carefully stand YARD CRUISER on rear bumper.
5. Remove blade(s). See Figure 4.15.
6. Inspect condition of blade. Refer to Figure 4.14.
7. If blade is in good condition, sharpen at 22 to 28 degrees. DO NOT sharpen beyond existing cutting edge. See Figure 4.17.
8. Check blade balance after sharpening. If necessary, correct blade balance by grinding the heavy end of blade.
9. Reinstall blade. See Figure 4.16. Torque blade mounting bolts to recommended range of:
33" Deck - 30 to 40 ft. lbs.
38" Deck - 80 to 90 ft. lbs.

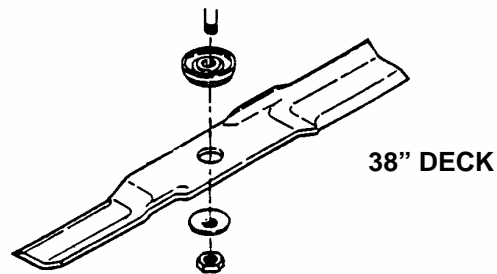
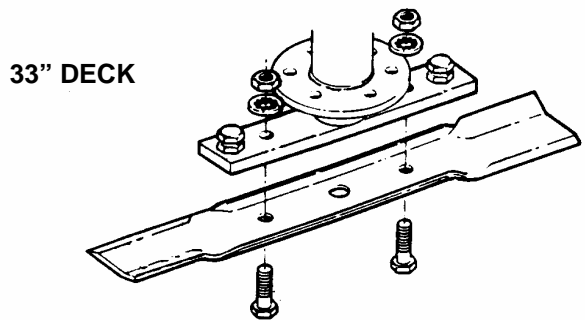

FIGURE 4.16

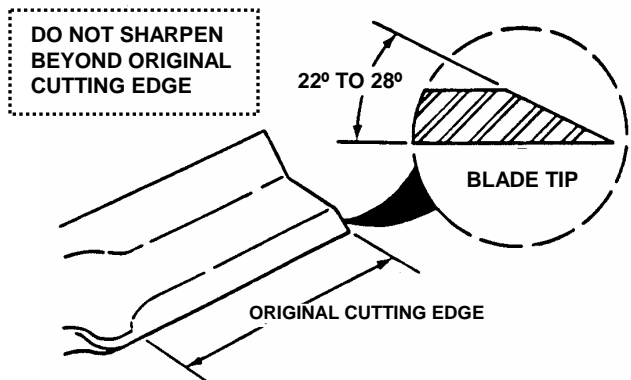

FIGURE 4.17

Section 4 - ADJUSTMENTS & REPAIR

WARNING

Before attempting any adjustments or repairs, STOP the engine, remove the key, remove the spark plug wire(s) from the spark plug(s) and secure wire(s) away from plug(s). Never attempt to service or charge the battery while it is installed on the YARD CRUISER. Shield the positive terminal with terminal cover located on battery harness. This prevents metal from touching the positive terminal which could cause sparks. Cables must be connected to battery terminals in the proper position as shown in Figure 4.17.

4.4 MOWER BLADE REPAIR/REPLACEMENT

4.4.3. BLADE REPLACEMENT

1. Remove blade(s). Refer to Figure 4.17. Replace blade(s) if it shows signs of excessive wear or damage. See chart below for replacement

BLADE REPLACEMENT CHART	
33" Blade	1-9523
38" Blades	2-4466 (Requires Two)

4.5 BATTERY

4.5.1. BATTERY REMOVAL

1. Tilt seat up to gain access to battery.
2. Observe and note cable positions on battery. See Figure 4.18.
3. Disconnect cables from battery terminals, disconnecting BLACK (Negative) cable first. Disconnect RED (Positive) battery cable. Slide battery from battery cradle.
4. Retain mounting bolts and nuts for future use.

4.5.2. BATTERY INSTALLATION

1. Slide battery into battery cradle.
2. Connect cables to battery terminals. Connect RED (Positive) cable first. Connect BLACK (Negative) cable. See Figure 4.18.
3. Place the positive (+) terminal insulator over positive terminal and cable. See Figure 4.18.

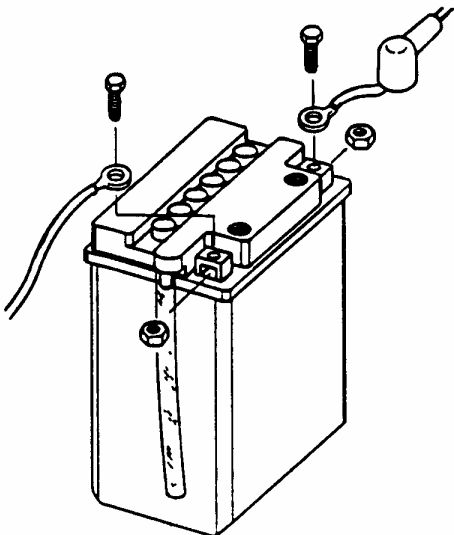

FIGURE 4.18

WARNING

The electrolyte (acid) produces a highly explosive gas. Keep all sparks, flame and fire away from area when charging battery or when handling electrolyte or battery. Electrolyte (acid) is a highly corrosive liquid. Wear eye protection. Wash affected areas immediately after having eye or skin contact with electrolyte (acid). Battery acid is corrosive. Rinse empty acid containers with water and mutilate before discarding. If acid is spilled on battery, bench, or clothing, etc., Flush with clear water and neutralize with baking soda. Never attempt to charge battery while installed on the YARD CRUISER. Never use "BOOST" chargers on the battery.

4.5.3. BATTERY SERVICE

1. Remove battery. See Section on Battery Removal
2. Place battery in a well ventilated area on a level surface.
3. Using distilled water, refill cells as required to cover cell plates of which can also be visualized through the plastic battery case.
4. With cell caps removed, connect battery charger to battery terminals. Red to positive (+) terminal and black to negative (-) terminal.
5. Slow charge battery at 1 amp for 10 hours.
6. If battery will not accept charge or is partially charged after 10 hours of charging at 1 amp, replace with new battery, Part Number 6-0753.

4.5.4. BATTERY STORAGE

If YARD CRUISER is to be stored out of season on its rear bumper, it is recommended the battery be removed, charged and stored.

1. Remove battery. (See 4.5.1., Battery Removal)
2. Perform battery service.
3. Bring battery to full charge, if required.
4. Store battery in an area away from the YARD CRUISER on a wood surface. DO NOT STORE BATTERY ON A CONCRETE SURFACE.

Section 4 - ADJUSTMENTS & REPAIR

4.5.5. BATTERY TESTING

There are two types of battery tests: Unloaded and Loaded. The unloaded test is the procedure that will be discussed. It's the simplest and most commonly used. An unloaded test is made on a battery without discharging current. To perform unloaded testing, check charge condition using either a hydrometer or voltmeter.

1. Using a voltmeter, voltage readings appear instantly to show the state of charge. Remember to hook the positive lead to the battery's positive terminal, and the negative lead to the negative terminal.

2. A hydrometer measures the specific gravity of each cell. The specific gravity tells the degree of charge; generally, a specific gravity of about 1.265 to 1.280 indicates full charge. A reading of 1.230 to 1.260 indicates the battery should be charged. The chart on the next page shows the charge level as measured by syringe float hydrometer, digital voltmeter and five ball hydrometer.

4.5.6. NEW BATTERY PREPARATION

1. Remove battery from carton.
2. Place battery in a well ventilated area on a level non-concrete surface.
3. Remove battery cell caps. Fill cells as required with electrolyte (purchased separately) to proper level. Fill to 3/16" above cell plates. Filling battery with electrolyte will bring the battery to 80% charged state.
4. With cell caps removed, connect battery charger to battery terminals; RED to positive (+) and BLACK to negative (-) terminal.

IMPORTANT: 3/16" above cell plates is the recommended level. However do not try to measure this dimension. Never place anything in battery other than specified electrolyte.

5. Slow charge the battery at 1 amp for 2 hours to bring the battery to full charge.
6. After charging, check level of electrolyte and add as needed to bring level to 3/16" above cell plates.
7. Reinstall cell caps.
8. Install battery into power unit. Connect over flow tube.
9. Connect positive (+) cable (red) first, from wiring harness to the positive terminal (+) on battery using bolt and nut provided in hardware bag. Connect negative (-) cable (black) last, to negative terminal (-) on battery using bolt and nut. Apply a small amount of grease over terminals to prevent corrosion.

WARNING

Shield the positive terminal with terminal cover located on battery harness. This prevents metal from touching the positive terminal which could cause sparks.

WARNING

DO NOT OVERFILL! Never attempt to charge battery while installed on the Yard Cruiser. Never use "BOOST" chargers on the battery.

4.5.7. BATTERY TESTING

Methods of Checking Battery Condition			
State of Charge	Syringe Hydrometer	Digital Voltmeter	Five Ball Hydrometer
100% Charged w/ Sulfate Stop	1.280	12.80v	Five Balls Floating
100% Charged	1.265	12.60v	Four Balls Floating
75% Charged	1.210	12.40v	Three Balls Floating
50% Charged	1.160	12.10v	Two Balls Floating
25% Charged	1.120	11.90v	One Ball Floating
0% Charged	Less than 1.100	Less than 11.80v	Zero Balls Floating

TROUBLESHOOTING

PROBLEM	PROBABLE CAUSE	CORRECTIVE ACTION
Starter Will Not Crank Engine	1. Battery dead.	1. Service battery.
	2. Blown fuse.	2. Replace fuse.
	3. Electrical connections loose or corroded.	3. Clean and check connections for good contact.
	4. Defective ignition switch.	4. Contact authorized SNAPPER dealer.
	5. Blade engagement switch in the "ON" position.	5. Move blade engagement switch to "OFF".
	6. Park brake not engaged.	6. Engage park brake.
	7. Faulty parking brake, blade or ignition switch.	7. Contact authorized SNAPPER dealer.
	8. Faulty engine starter.	8. Replace engine starter.
	9. Faulty starter solenoid	9. Replace starter solenoid.
Engine Will Crank But Not Start	1. Fuel tank empty or fuel shut-off valve closed.	1. Fill fuel tank with fresh fuel & open fuel valve.
	2. Engine needs choking.	2. Move choke control to "CHOKE" position.
	3. Spark plug wire disconnected.	3. Place spark plug wire onto spark plug.
	4. Battery weak or dead.	4. Service battery.
	5. Faulty parking brake, blade or ignition switch.	5. Contact authorized SNAPPER dealer.
Engine Will Not Start Using Recoil Starter	1. Blade engagement switch in the "ON" position.	1. Move blade engagement switch to "OFF".
	2. Park brake not engaged.	2. Engage park brake.
	3. Fuel tank empty or fuel shut-off valve closed..	3. Fill fuel tank with fresh fuel & open fuel valve.
	4. Engine needs choking.	4. Move choke control to "CHOKE" position.
	5. Blown Fuse.	5. Replace with new 20 AMP fuse.
	6. Faulty relay switch.	6. Contact authorized SNAPPER dealer.
	7. Faulty parking brake or blade switch.	7. Contact authorized SNAPPER dealer.
Engine Stalls After Running	1. Operator not in seat.	1. Sit in operator's seat.
	2. Choke control in the "CHOKE" position.	2. Move choke control to "OFF" position.
	3. Fuel tank empty.	3. Fill with fuel to proper level.
	4. Engine air pre-cleaner and or air cleaner dirty.	4. Clean free of all debris.
	5. Spark plug defective or gap set improperly.	5. Service spark plug.
	6. Fuel filter stopped up.	6. Replace fuel filter.
	7. Water, debris or stale fuel in fuel system.	7. Drain and clean fuel system.
Engine Loses Power	1. Excessive load on engine.	1. Lessen load.
	2. Engine air pre-cleaner or air cleaner dirty	2. Clean or replace filters.
	3. Spark plug faulty.	3. Service spark plug.
	4. Water, debris or stale fuel in fuel system.	4. Drain and clean fuel system.
	5. Debris build up on engine cooling screen.	5. Clean all debris from engine cooling screen.
Engine Backfires When Turned To "STOP"	1. Throttle control set too "FAST".	1. Set throttle control to "SLOW" and allow engine to idle. Then, turn key to "OFF".

(Trouble Shooting Continued on Next Page)

TROUBLESHOOTING

PROBLEM	PROBABLE CAUSE	CORRECTIVE ACTION
Excessive Vibration	1. Damaged, out of balance or bent mower blades.	1. Service mower blade(s).
	2. Loose blade components.	2. Service and tighten loose parts.
	3. Loose or missing air lift (if equipped).	3. Replace air lifts. Tighten to proper torque.
	4. Lumpy or frayed belt	4. Replace belt.
	5. Bent Idler, stationary or spindle pulley	5. Replace pulley.
Rider Will Not Move Or Loss Of Traction	1. Joystick in the neutral "N" position.	1. Place joystick in desired speed position.
	2. Roll release lever is in "ROLL" position.	2. Move roll release lever to the engaged position.
	3. Low transmission hydraulic oil level.	3. Contact authorized SNAPPER dealer.
	4. Parking Brake engaged.	4. Move parking brake to disengaged position..
	5. Traction drive belt requires replacement	5. Replace traction drive belt.
Blade(s) Not Cutting	1. Blade engagement switch in the "OFF" position.	1. Move blade switch to the "ON" position.
	2. Clutch belt slipping.	2. Replace clutch belt.
	3. Mower belt slipping.	3. Replace mower belt.
	4. Electric clutch not functioning.	4. Contact authorized SNAPPER dealer.
Cutting Grass Improperly	1. Uneven tire pressure.	1. Bring to proper pressure.
	2. Cutting height too low or high.	2. Adjust cutting height.
	3. Engine speed too slow.	3. Move throttle control to "FAST" position.
	4. Forward speed too fast.	4. Move joystick to a slower speed.
	5. Terraced cut, side to side.	5. Adjust side to side level
	6. Excessive deck pitch, front to rear.	6. Adjust front to rear pitch.
	7. Cutting blade(s) dull or damaged.	7. Sharpen cutting edges or replace blade(s).
	8. Blade belt slipping.	8. Replace blade belt.
	9. Check electric clutch.	9. Adjust to proper specifications. (33" Deck Only)
	10. Check clutch belt.	10. Replace clutch belt.
Poor Grass Discharge	1. Engine speed too slow.	1. Move throttle control to "FAST" position.
	2. Forward speed too fast.	2. Move joystick to a slower speed.
	3. Grass is wet.	3. Mow when grass is dry.
	4. Excessively worn or damaged blade(s).	4. Service mower blade(s)
	5. Build up of grass clippings and debris under deck.	5. Clean deck.
	6. Improper blade(s) installed on deck.	6. Install proper SNAPPER blades.
	7. Blade(s) installed improperly on deck.	7. Install blades properly.
Battery Will Not Charge	1. Poor cable connections.	1. Clean cables and battery terminals.
	2. Bad battery cell(s)	2. Replace with new battery.
	3. Faulty alternator.	3. Contact engine manufacturer's dealer.
Oil Leaking	1. Leaking hose fittings, clamps or reservoir.	1. Verify fittings and hose clamps are tight.

SERVICE SCHEDULE

ITEM	SERVICE PERFORMED	REF.	EACH USE	5 HRS	25 HRS	50 HRS	100 HRS	EACH SEASON
Engine Oil	Check Oil Level	Page 6	X					
	Initial Oil Change	Page 10		X				
	Periodic Oil Change	Page 11			X*			
Oil Filter	Initial Oil Change	Engine Manual & Page 10		X				
	Periodic Oil Change	Engine Manual & Page 10			X*			
Air Pre-Cleaner	Clean Sponge Element	Engine Manual.			X**			
Air Cleaner	Clean or Replace	Engine Manual.			X**			
Spark Plug	Replace	Engine Manual.					X	
Fuel Filter	Replace	Engine Manual.					X	
Engine Cooling System	Clean Shroud & Fins	Engine Manual & Page 11					X**	
Battery	Check Electrolyte	Page 20			X			X
	Charge Battery	Page 20						X
	Testing Battery	Pages 20-21						X
Tires	Check Pressures	Page 6	X					X
Drive Belts	Check For Wear And Tension	Page 14-15			X	X		X
Mower Blades	Check For Wear, Damage & Replacement	Pages 19-20	X					
Mower Deck	Clean Debris Accumulation	Page 11	X					
Mower Deck	Clean Outside and Underside	Page 11	X					
Lubrication Points	Grease or Oil	Pages 12			X			X

* Change oil every 25 hours when operating under heavy load or high temperatures.

**Clean more often under dusty conditions or when air debris is present

4.6. MAINTENANCE/REPLACEMENT PARTS

MAINTENANCE/REPLACEMENT PARTS	
Throttle Control Cable (Briggs 13 HP)	4-6259
Cutter Deck Blade (33" Cutting Deck)	3-4168
Cutter Deck Blade (38" Cutting Deck) (2 Blades Required)	4-2998
33" Cutter Deck Belt (Electric Clutch to Cutting Deck)	3-5389
38" Cutter Deck Belt (Electric Clutch to Cutting Deck)	2-9308
Wheel Drive Belt (Engine to Hydro Transaxle)	4-1823
Mower Drive Belt (Engine to Electric Clutch)	2-9117
Parts Manual for Yard Cruiser Series 1 & 2 Models: YZ13331BE, YZ13381BE, YZ145332BE, YZ145382BE	06118

SNAPPER®

3 YEAR LIMITED WARRANTY

For three (3) years from purchase date for the original purchaser's residential, non-commercial use, **SNAPPER**, through any authorized **SNAPPER** dealer will replace, free of charge (except for taxes where applicable), any part or parts found upon examination by the factory at McDonough, Georgia, to be defective in material or workmanship or both.

For ninety (90) days from purchase date for the original purchaser's commercial, rental, or other non-residential use, **SNAPPER**, through any authorized **SNAPPER** dealer will replace, free of charge, any part or parts found upon examination by the factory at McDonough, Georgia, to be defective in material or workmanship or both.

All transportation costs incurred by the purchaser in submitting material to an authorized **SNAPPER** dealer for replacement under this warranty must be paid by the purchaser.

This warranty does not apply to engines and their components, and batteries, as these items are warranted separately. This warranty does not apply to parts that have been damaged by accident, alteration, abuse, improper lubrication, normal wear, or other cause beyond the control of **SNAPPER**. This warranty does not cover any machine or component part that has been altered or modified changing safety, performance, or durability.

Batteries have a one (1) year prorated warranty period with free replacement if required during the first ninety (90) days from the original purchase date. **SNAPPER** will not be responsible for any installation cost incurred. The battery warranty only covers original equipment batteries and does not cover damage to the battery or machine caused by neglect or abuse, destruction by fire, explosion, freezing, overcharging, improper maintenance, or use of improper electrolyte.

There is no other express warranty.

DISCLAIMER OF WARRANTY

Implied warranties, including those of merchantability and fitness for a particular purpose, are limited to three (3) years from purchase date for the original purchaser's residential or other non-commercial use, and ninety (90) days from purchase for the original purchaser's commercial, rental or other non-residential use, and to the extent permitted by law, any and all implied warranties are excluded. This is the exclusive remedy. Liabilities for consequential damages, under any and all warranties are excluded.

Some states do not allow limitations on how long an implied warranty lasts, or do not allow the exclusion or limitation of incidental or consequential damages, so the above limitation or exclusion may not apply to you.

This warranty gives you specific legal rights, and you may also have other rights which vary from state to state.

WARNING: THE USE OF REPLACEMENT PARTS OTHER THAN GENUINE SNAPPER PARTS MAY IMPAIR THE SAFETY OF SNAPPER PRODUCTS AND WILL VOID ANY LIABILITY AND WARRANTY BY SNAPPER ASSOCIATED WITH THE USE OF SUCH PARTS.

IMPORTANT: Please fill out the attached **SNAPPER** Product Registration Card immediately and mail to:
Snapper's Product Registration Center, P.O. Box 1379, McDonough, Georgia 30253

PRIMARY MAINTENANCE

SNAPPER®

VS. DIRT!

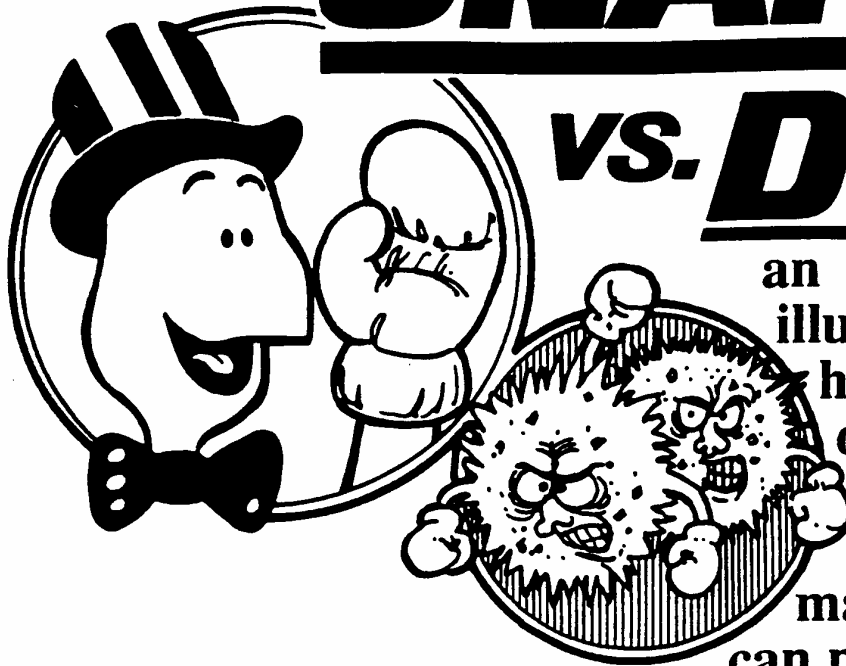

an illustration of how dirt can damage your engine & how reasonable maintenance can protect it!

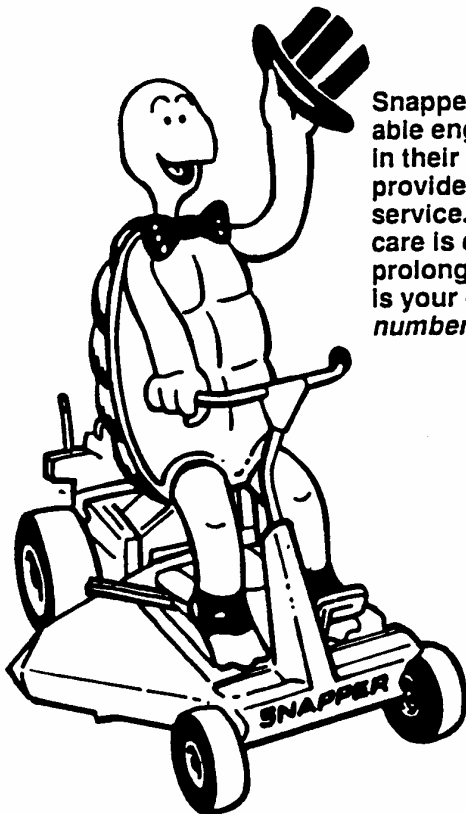

Snapper uses the best available engines and components in their products in order to provide long, satisfactory service. However, proper care is essential in prolonging engine life. Dirt is your engine's *enemy number 1!*

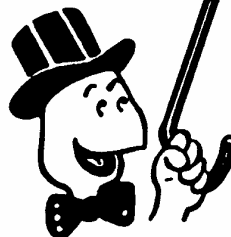
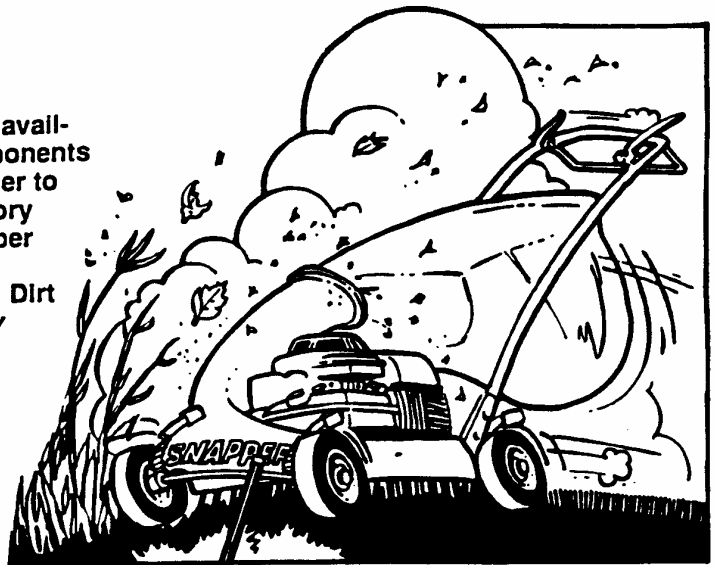

The engine on your Snapper product spends its entire life operating close to the ground at high speed creating a virtual storm of dust and dirt!

PRIMARY MAINTENANCE

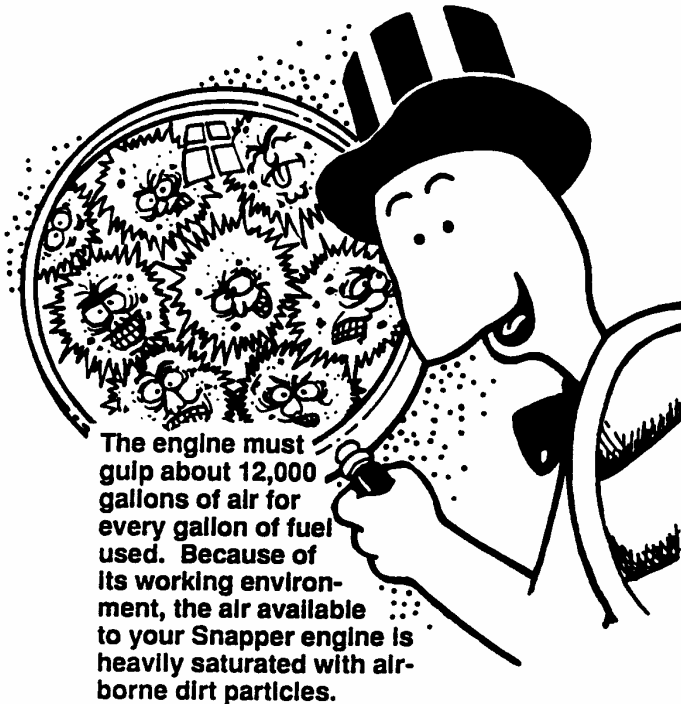

The engine must gulp about 12,000 gallons of air for every gallon of fuel used. Because of its working environment, the air available to your Snapper engine is heavily saturated with airborne dirt particles.

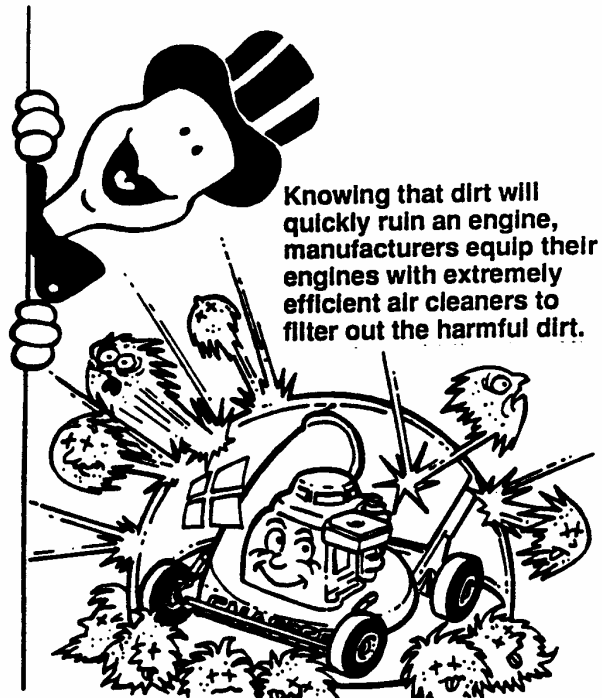

Knowing that dirt will quickly ruin an engine, manufacturers equip their engines with extremely efficient air cleaners to filter out the harmful dirt.

As the dirt particles are stopped, they build up and begin to clog the outside of the filter. This reduces the amount of air available to the engine and causes an over-rich fuel mixture which results in the following adverse effects:

An improperly serviced, dirt clogged air cleaner will:

1. Increase fuel consumption
2. cause power loss
3. result in hard starting
4. create smoke from unburned fuel
5. produce carbon build-up internally
6. foul spark plug electrodes
7. score cylinder walls
8. burn valves
9. wear out the engine prematurely
10. COST YOU MONEY!

Damage caused by a poorly serviced air cleaner is not covered under the engine warranties. So, save yourself unnecessary expenses and undue aggravation by keeping the air cleaner properly serviced at the intervals specified in the engine owner's manual.

It doesn't take long to service an air cleaner. Follow the specific instructions in the engine owner's manual for the type filter used. Prevent dirt from falling into the carburetor intake when servicing your air cleaner. Make sure components are installed in correct sequence after servicing to prevent unfiltered air from entering the engine. Some servicing hints on several common types are:

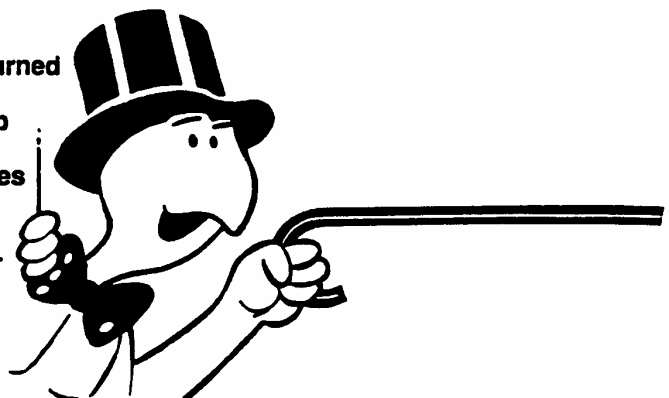
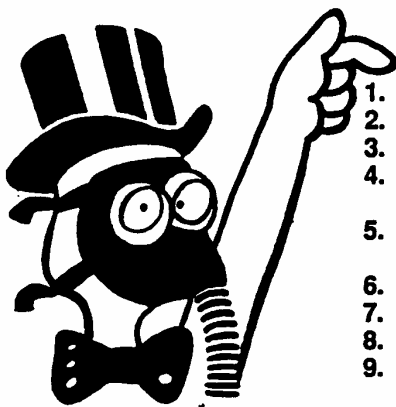

PRIMARY MAINTENANCE

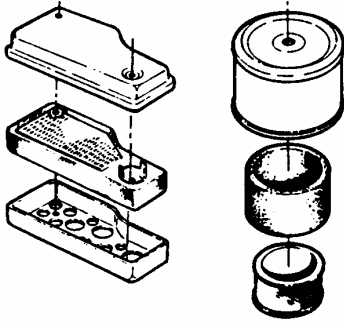

Generally, wash foam-type filters in a dishwashing detergent and water solution. Rinse and wring dry, then saturate with oil and squeeze out excess. *Failure to re-oil this type filter will ruin the engine.*

Clean paper elements by tapping lightly. Blowing with air will rupture paper elements.

Use a flashlight to detect clogged or torn paper elements - replace if damaged in any way.



Air is also needed to keep your engine cool. Dirt, dust & debris build up to restrict and clog cooling air intake screens and fins. Clean screens and fins at frequent intervals. The engine blower housing and shrouds should be removed at least once each season or more often under dry, dusty conditions for a thorough cleaning of fins.

Failure to keep external surfaces clean not only presents fire hazards, but causes overheating and resulting engine damages such as:

1. distorted valve guides
2. sticking valves
3. scuffed, scored cylinder walls
4. overspeeding
5. loss of power
6. complete failure of engine.

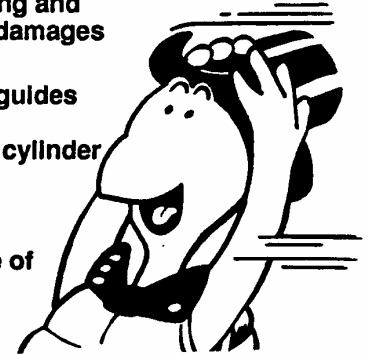

Dirt can also be introduced into an engine in dirty fuel from a contaminated container. Always use clean fresh fuel from a clean container to guard against dirt, sludge and water contamination.

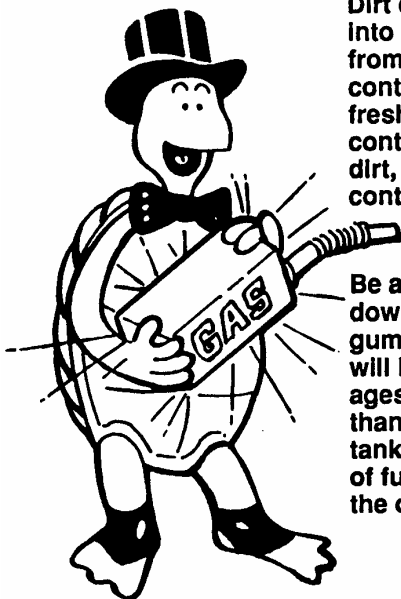

Be aware that fuel breaks down in storage and forms gummy compounds which will block carburetor passages. Never use fuel more than 3 months old. Drain tank then run the engine out of fuel before storing during the off-season.



An engine must also have proper lubrication. All engines use some oil. On 4-cycle engines, **CHECK OIL LEVEL BEFORE EACH START-UP.** Wipe area clean around the oil check plug or dipstick opening to keep dirt from falling into the engine when checking the oil. Always check with the machine on a level surface. On engines with dipstick, keep the level up to, but not over, the **FULL** mark. When adding oil, allow time for all of the oil to flow down the fill tube to prevent a false full reading when the level could actually be low and result in engine damage.

PRIMARY MAINTENANCE

On 4-cyle engines with an oil level plug, don't be fooled into thinking the engine has sufficient lubricating oil if you can see "some" oil in the opening - the level should always be brought up to the point of overflowing at the top of the fill hole.

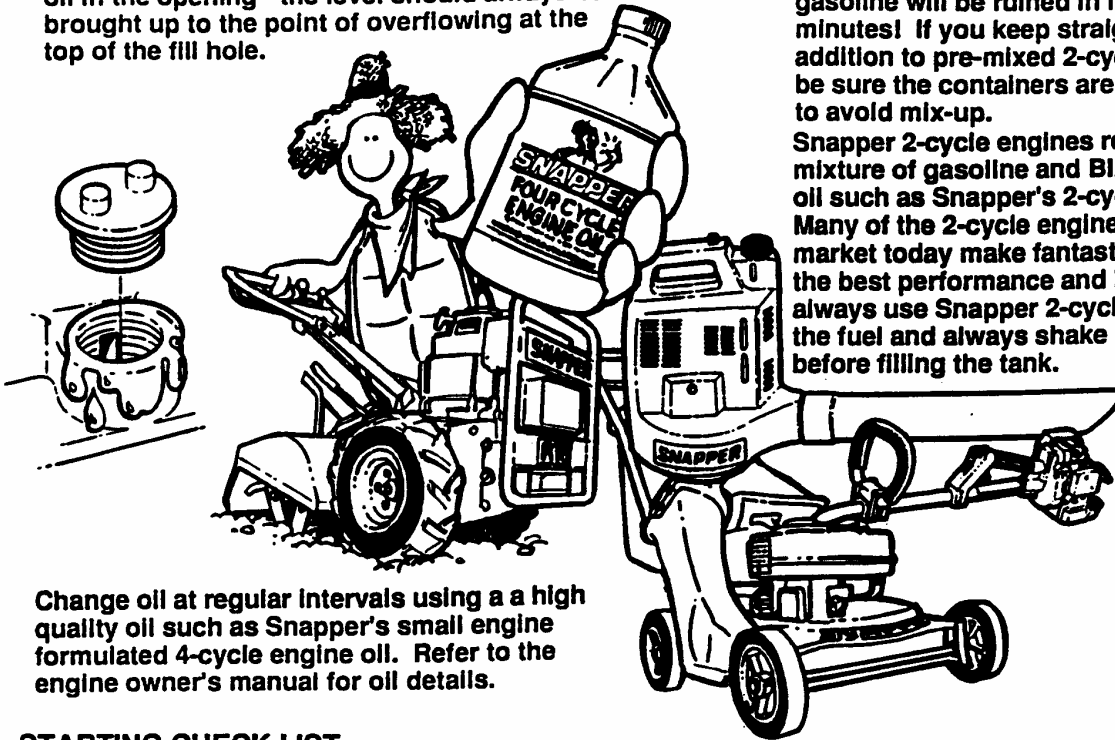

On 2-cycle engines, lubrication must be provided by an exact mixture of gasoline and 2-cycle air-cooled engine oil. A 2-cycle engine that is mistakenly run on straight gasoline will be ruined in less than 5 minutes! If you keep straight gasoline in addition to pre-mixed 2-cycle engine fuel, be sure the containers are clearly marked to avoid mix-up.

Snapper 2-cycle engines require a 32 to 1 mixture of gasoline and BIA certified TC-W oil such as Snapper's 2-cycle engine oil. Many of the 2-cycle engine oils on the market today make fantastic claims, but for the best performance and long engine life, always use Snapper 2-cycle oil. Pre-mix the fuel and always shake the container before filling the tank.

Change oil at regular intervals using a high quality oil such as Snapper's small engine formulated 4-cycle engine oil. Refer to the engine owner's manual for oil details.

STARTING CHECK LIST

- | | |
|-------------------------------|--|
| 1. Engine Oil | <ul style="list-style-type: none"> • To full level (4-cycle) • Properly mixed with gas (2 cycle) |
| 2. Air Cleaner | <ul style="list-style-type: none"> • Clean and properly serviced • Full fresh clean gasoline |
| 3. Fuel Tank | <ul style="list-style-type: none"> • Fuel valve open • Cap vent open • Inline filter clean |
| 4. Choke | <ul style="list-style-type: none"> • Operating properly |
| 5. Primer (on some engines) | <ul style="list-style-type: none"> • Used properly |
| 6. Safety Inter-lock Switches | <ul style="list-style-type: none"> • In proper position • All wires properly connected |
| 7. Switch & Blade Control | <ul style="list-style-type: none"> • Switch On • Blade control properly positioned on walk mower |
| 8. Spark plug | <ul style="list-style-type: none"> • Wire connected • Good connection • Start position |
| 9. Throttle control | |
| 10. Blade | <ul style="list-style-type: none"> • Properly installed and torqued • Sharpened |
| 11. Muffler | <ul style="list-style-type: none"> • Good condition • Not clogged • Grass & leaves cleaned away |

Read and follow all safety instructions in safety booklets and manuals.

Keep in mind that dirt is your engine's *enemy #1* both internally and externally! Internally, dirt will quickly ruin an engine and externally it will cause overheating and resulting internal damages. Damage caused by improper lubrication, poor air cleaner service or overheating due to dirt cannot be covered under warranty.

It only takes a few moments to service the engine (and equipment) on a routine basis but the rewards will be a quick starting, responsive engine that will provide long satisfactory service with minimum maintenance cost. The prestart checklist in the next column and instructions in your Snapper Operator's Manual are designated to help you keep your Snapper in top operating condition with minimum effort!

Safety Instructions & Operator's Manual for

SNAPPER®

YARD CRUISER

HYDRO DRIVE

SERIES 1 & 2



WARNING:

The engine exhaust from this product contains chemicals known to the State of California to cause cancer, birth defects or other reproductive harm.

SNAPPER® McDonough, GA., 30253 U.S.A.

COPYRIGHT © 1999
SNAPPER INC.
ALL RIGHTS RESERVED

(REV. 2, 3/13/00)

MANUAL No. 4-6359