

Service Manual for

SNAPPER®

**21" SERIES 0
REAR DISCHARGE
CAST ALUMINUM
MODELS XP21500 &
XP21501 (SELF-
PROPELLED)
& X21500 (PUSH)
WALK BEHIND
MOWERS**

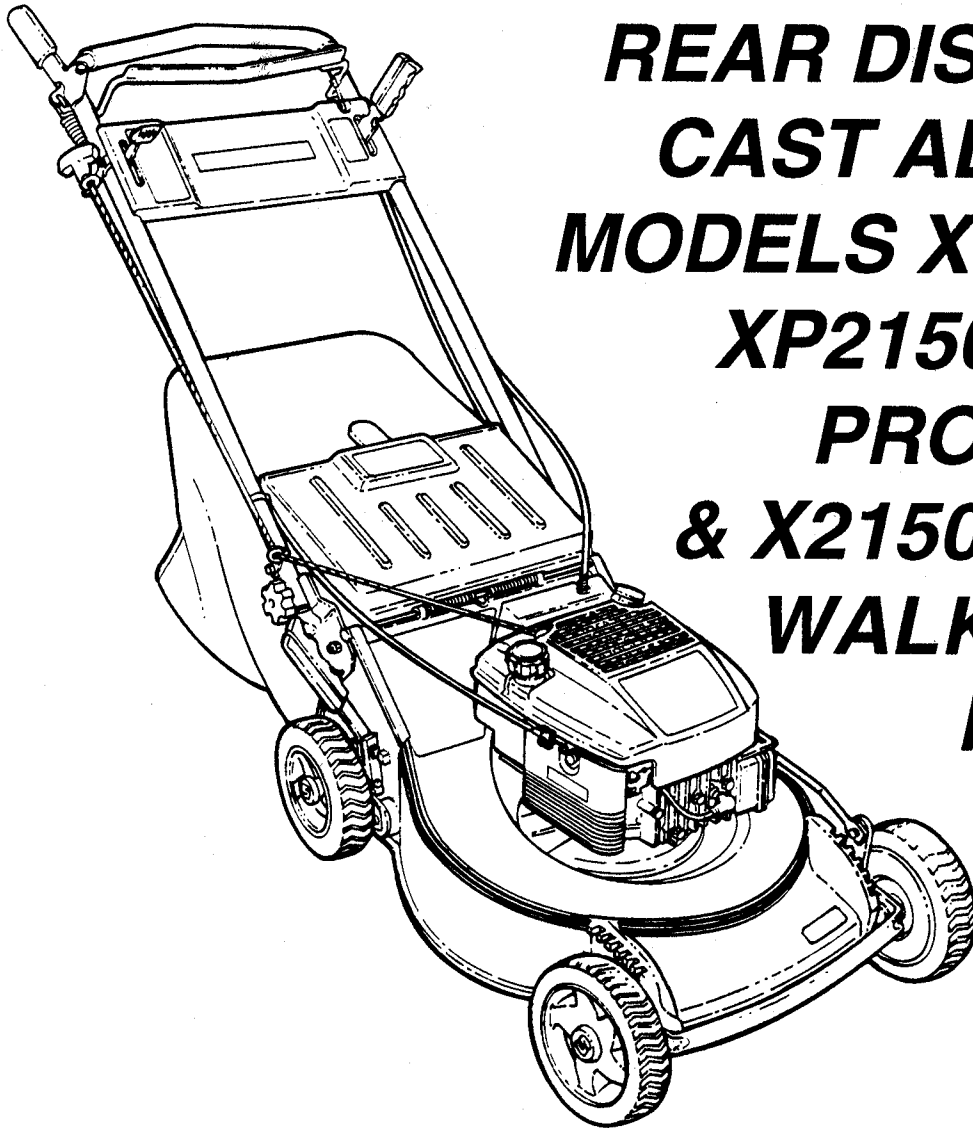

**NOTE! THE SERIES
NUMBER IS THE
LAST NUMBER IN
THE FIVE DIGIT
MODEL DESIGNATION.**

SNAPPER® McDonough, GA., 30253 U.S.A.

MANUAL No. 07009 (I.R. 8/93)

TABLE OF CONTENTS

SECTION I	
INTRODUCTION	3
1.1 Introduction.....	3
1.2 Nomenclature	3
SECTION II	
OPERATING INSTRUCTIONS	4-6
2.1 Before Operating	4
2.2 Stopping	4
2.3 Pre-Start Check List.....	4
2.4 Starting/Stopping Engine	4
2.5 Ground Speed Control	4
2.6 Electric Start	4-5
2.7 Cutting Height Adjustment	5
(a) (Single Point Height Adjustment)	5
(b) (Individual Wheel Height Adjustment)	5
2.8 Handle Height Adjustment.....	5
2.9 Grass Catcher	5
2.10 Mowing Procedure	6
SECTION III	
MAINTENANCE & ADJUSTMENTS	7-15
3.1 Lubrication Schedule.....	7-8
(a) Briggs & Stratton (5 HP & 5.5 HP).....	7
(b) Briggs & Stratton (AFTER FIRST 5 HOURS)	7
(c) Kawasaki Engines Only	7
(d) Transmission.....	7-8
(e) Wheel Pivots	8
3.2 Cutting Blade Service	8-9
3.3 Drive Belt Service	9
3.4 Driven Disc (Rubber Tire) Checking/Adjustment.....	9-10
3.5 Driven Poly-V Belt Replacement	10-12
3.6 Drive Disc (Rubber Tire) Replacement	12
3.7 Driven Disc Assembly and/or Bearing Replacement.....	12
3.8 Drive-V Belt Replacement.....	13-14
3.9 Speed Selector Assembly	14
3.10 Linkage Assembly (Single Point Height of Cut).....	14
3.11 Trail Shield & Cross Shaft Removal	15
3.12 Transmission Removal (Single Point Height of Cut)	15
SECTION IV	
TROUBLESHOOTING.....	16-17
SECTION V	
OVERHAUL & REPAIR	18-25
5.1 Transmission Tests (Self-Propelled).....	18
5.1 To Test Transmission	18
5.2 Transmission Removal.....	18
5.3 Transmission Disassembly.....	19-20
5.4 Transmission Rebuilding	20-23
(a) Bull Gear	21-22
(b) Housings	22-23
5.5 Transmission Reassembly	23-25
SECTION VI	
ELECTRICAL	26
6.1 Battery Removal and Installation.....	26

Section I - INTRODUCTION

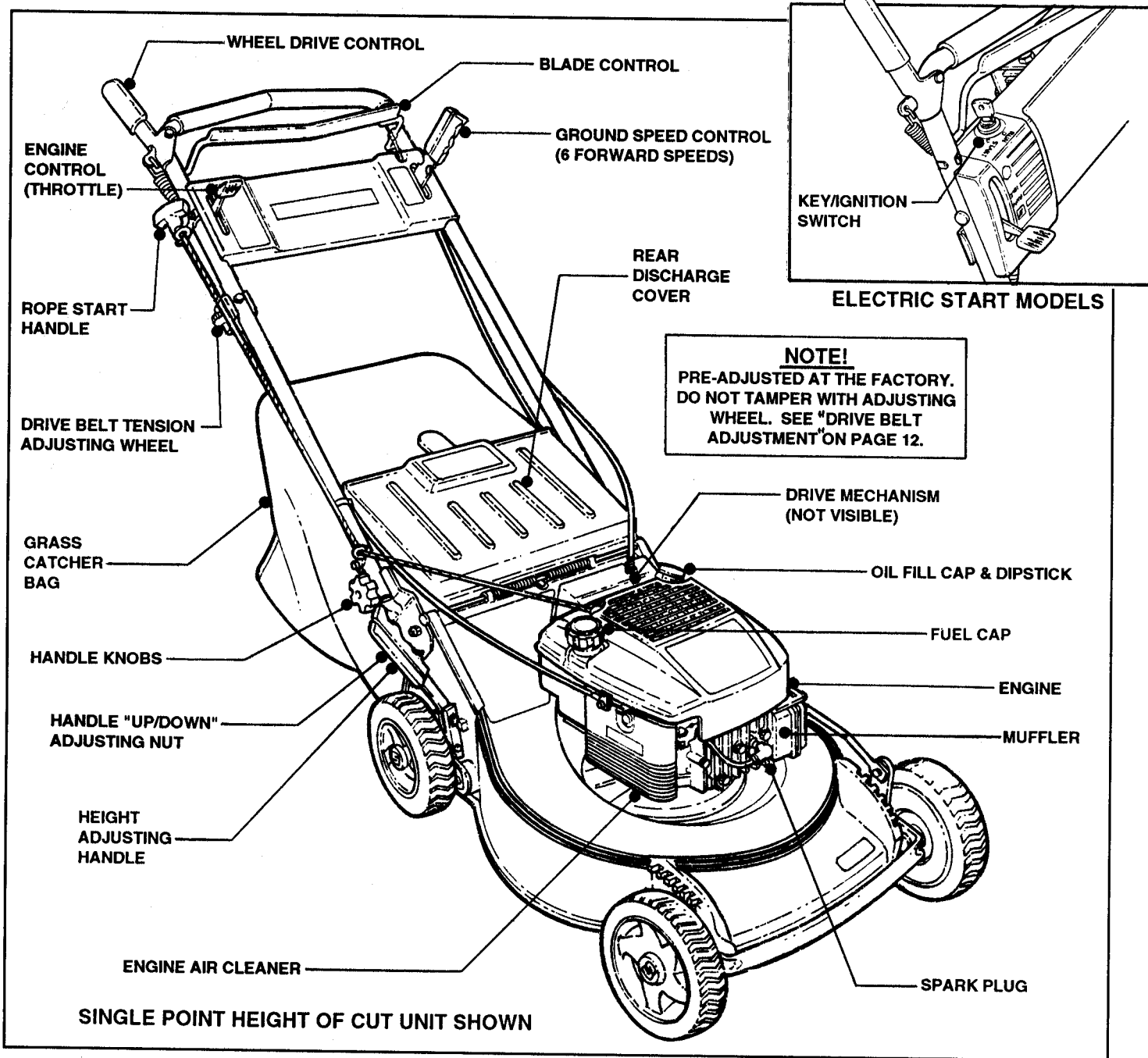

FIGURE 1.1

1.1 INTRODUCTION

This manual covers the operation and routine service of all SNAPPER REAR DISCHARGE 21" CAST ALUMINUM DECK WALK BEHIND MOWERS. Its purpose, aside from recommending operating and routine service requirements, is to promote safety through the use of accepted operating practices. **READ, UNDERSTAND AND FOLLOW** the SAFETY PRECAUTIONS in the Operator's Manuals and on the individual mower before operating or servicing any machine.

1.2 NOMENCLATURE

The nomenclature drawing above (Figure 1.1) shows the essential parts of the SNAPPER SINGLE POINT HEIGHT ADJUSTMENT, WALK BEHIND MOWER (other rear discharge mowers are similar). It is recommended that all operators of this equipment become thoroughly familiar with the controls, parts and operation of this machine before operating. Specific details involving the engine are found in the separate Engine Owner's Manual. Study these manuals before operating and keep both handy for future reference.

Section II - OPERATING INSTRUCTIONS

2.1 BEFORE OPERATING:

Be thoroughly familiar with all controls and how to use them before operating your mower. **Know beforehand how to STOP the engine, wheel drive and mower blade in preparation for possible emergencies.**

2.2 STOPPING

- ENGINE: **STOP ENGINE** by releasing the BLADE CONTROL. See Figure 2.1.
- MOWER BLADE: **STOP MOWER BLADE** by releasing the BLADE CONTROL.
- WHEEL DRIVE: **STOP FORWARD MOTION** of mower by releasing WHEEL DRIVE CONTROL.

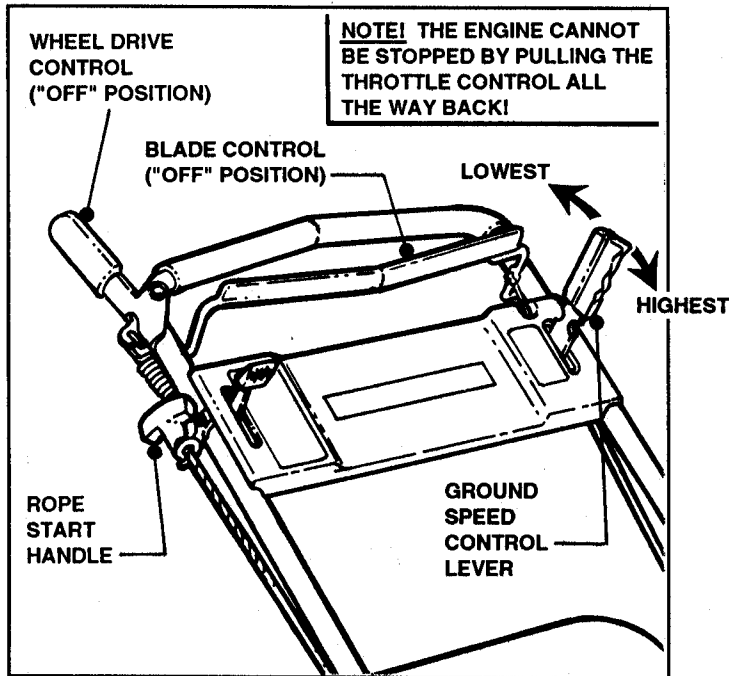

FIGURE 2.1

2.3 PRE-START CHECK LIST

Make the following checks and perform the service as required before each start-up.

- CLEAN EXTERIOR SURFACES of cutting deck and engine of any accumulation of dirt, grass, oil, etc. Keep engine air intake screens and cooling fins clear at all times.
- CHECK ENGINE OIL and add oil as needed to bring level up to (but not over) the full mark. (Refer to Engine Manual for oil specifications).
- CHECK BLADE CONTROL to insure that it works freely.
- CHECK CUTTING HEIGHT. Adjust as required.
- CHECK GUARDS AND GRASS BAG to make sure they are in proper position and secure.
- CHECK FUEL LEVEL in tank after pushing mower outdoors where fumes are safely dissipated.

2.4 STARTING/STOPPING ENGINE

1. Move THROTTLE to CHOKE position.
2. Hold BLADE CONTROL against handlebar with left hand.
3. Pull ROPE START HANDLE until engine starts. Refer to Figure 2.1.
4. After engine has warmed up, move THROTTLE to "FAST" position to begin mowing.
5. Stop engine by releasing BLADE CONTROL.

2.5 GROUND SPEED CONTROL

The mower has six (6) forward speeds. The GROUND SPEED CONTROL LEVER is moved inward and then forward to increase ground speed or rearward to decrease ground speed. Change ground speed for varying grass conditions, not engine speed. See Figure 2.2.

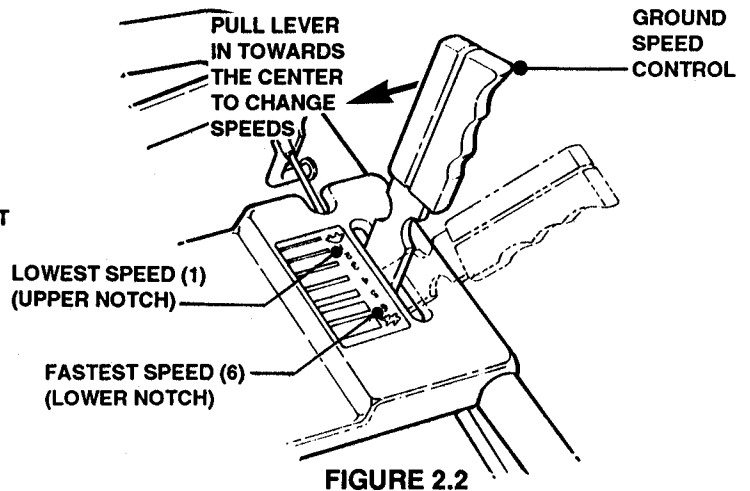

FIGURE 2.2

NOTE!
DO NOT move the GROUND SPEED CONTROL LEVER unless the engine is running!

2.6 ELECTRIC START

The KEY/IGNITION Switch has two positions - RUN & START. The engine **CANNOT** be stopped at the Switch! **STOP ENGINE** by releasing the BLADE CONTROL. See Figure 2.3.

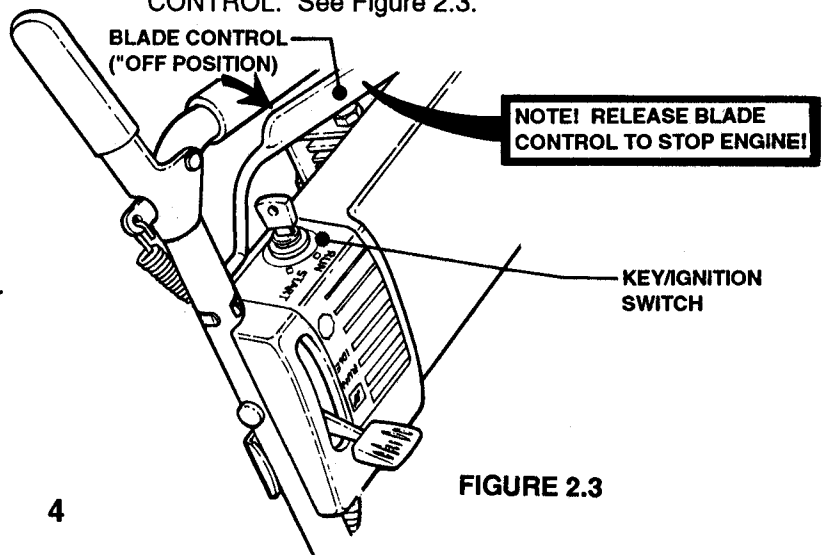

FIGURE 2.3

Section II - OPERATING INSTRUCTIONS

1. Move ENGINE CONTROL LEVER THROTTLE to START position and hold BLADE CONTROL against handlebar.
2. Turn the IGNITION KEY to START position and hold until the engine starts, then release.

2.7 CUTTING HEIGHT ADJUSTMENT

(a) (Single Point Height Adjustment)

1. Pull ADJUSTING HANDLE out towards the wheel and move to desired notch. Move handle to lock in position. See Figure 2.4.

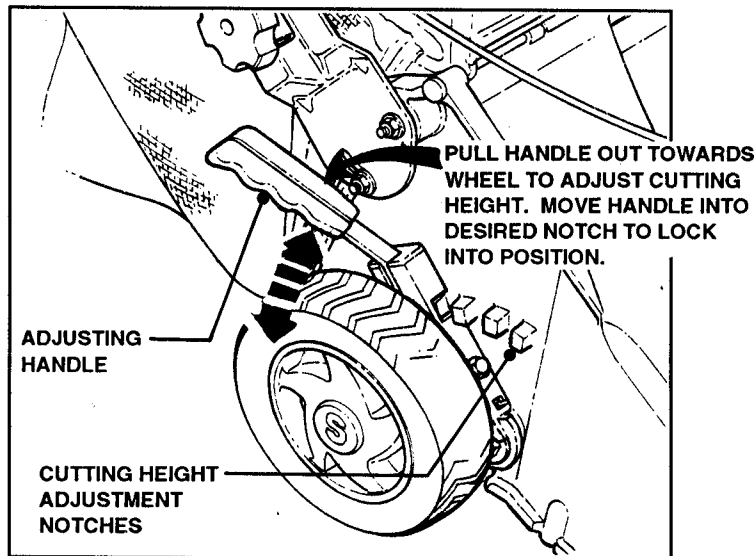

FIGURE 2.4

2. Push the handle all way forward for lowest cutting position.
3. Pull handle all way to the rear for highest cutting position.

(b) (Individual Wheel Height Adjustment)

Stop engine and adjust *blade cutting height* as follows:

1. Pull the ADJUSTING LATCH out towards the wheel and move to desired notch. Move handle into notch to lock in position. See Figure 2.5.

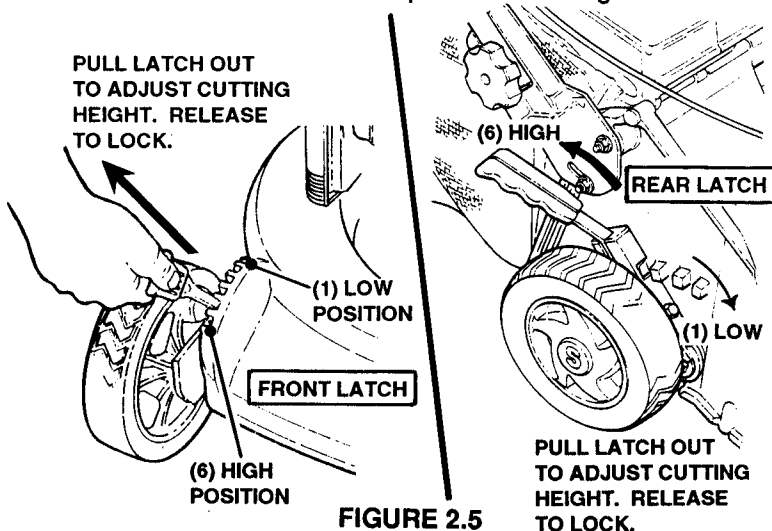

FIGURE 2.5

2. The highest cutting position is attained when all the latches are set in notch 6.
3. The lowest cutting position is with latches set in notch 1.

2.8 HANDLE HEIGHT ADJUSTMENT (All Models)

The bottom hole on each handlebar support is slotted to allow for handlebar height adjustment. See Figure 2.6.

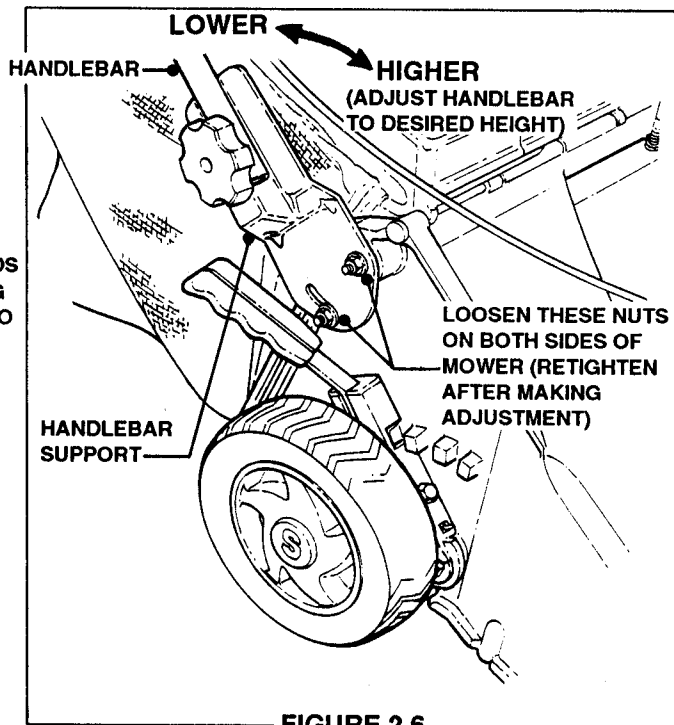

FIGURE 2.6

2.9 GRASS CATCHER (All Models)

To install or remove the *Grass Catcher*, proceed as follows:

1. Stop engine.
2. Lift rear discharge cover.
3. Grasp handle and hold *Grass Catcher* up while inserting over tabs at rear of mower deck. See Figure 2.7.
4. Reverse procedure to remove *Grass Catcher*.

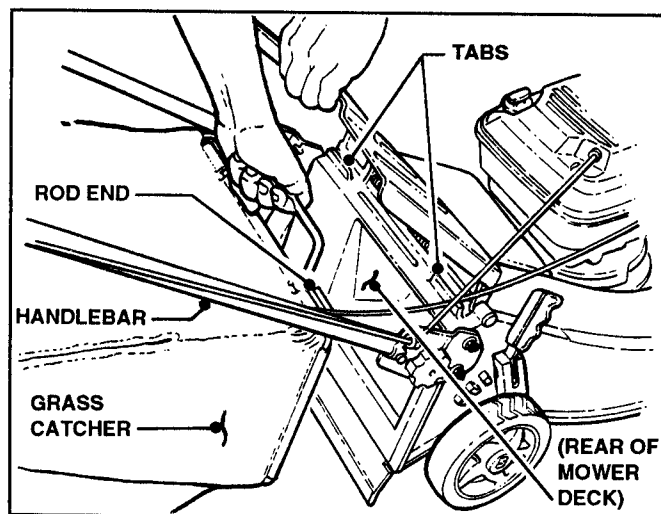

FIGURE 2.7

Section II - OPERATING INSTRUCTIONS

2.10 MOWING PROCEDURE

1. Perform PRE-START CHECK LIST.
2. Move mower to flat spot in area to be mowed.
3. Observe surroundings. Make sure there are no bystanders, children or animals in, or close by, the area to be mowed. Pick up any toys, sticks, etc., that could be thrown out by the mower blade. Make NOTE of any potential hazards.
4. Start mower engine.
5. Move THROTTLE to "FAST" engine speed.
See Figure 2.8.

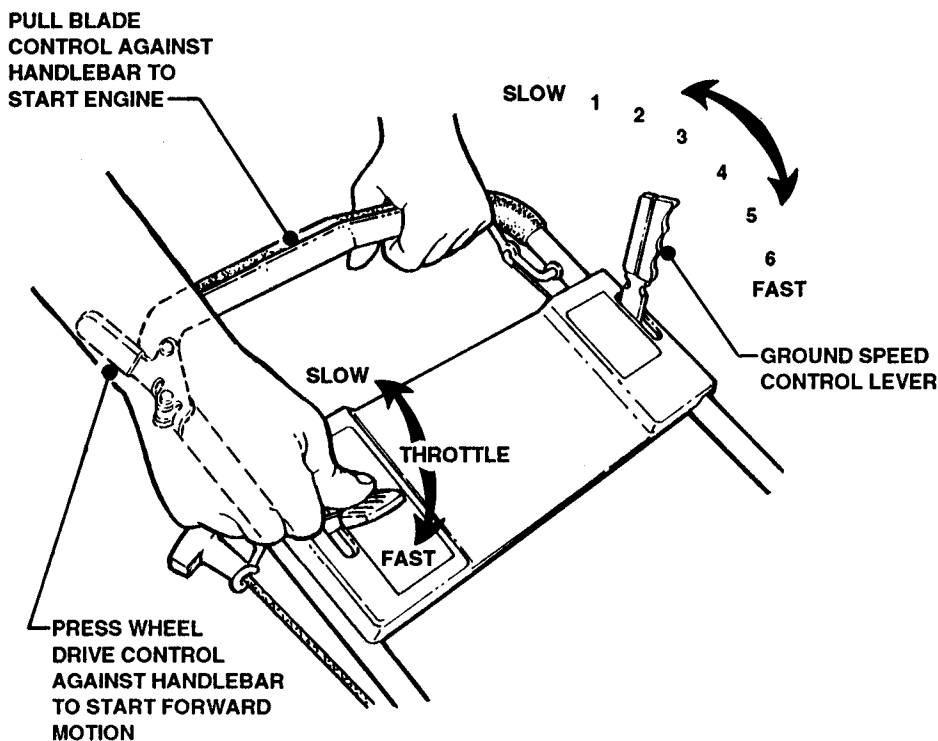
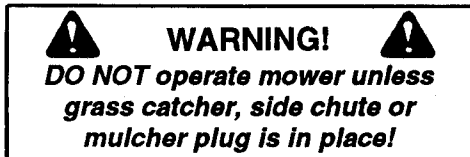

FIGURE 2.8

6. Move GROUND SPEED CONTROL LEVER to desired speed setting until you become familiar with the mower, SNAPPER recommends that the GROUND SPEED CONTROL LEVER be kept in a low-speed position (1 or 2).
7. Press WHEEL DRIVE CONTROL against handlebar to start forward motion. Refer to Figure 2.8.

Section III - MAINTENANCE & ADJUSTMENTS

WARNING!
Disconnect wire from spark plug before inspecting or servicing any part of the mower!

3.1 LUBRICATION SCHEDULE

(a) ENGINE (AFTER FIRST 5 HOURS!) (BRIGGS & STRATTON ENGINES ONLY)

1. Same as Steps 1 through 3 below (b).
2. For 5 HP or 5.5 HP engines, use 16 oz. (480 milliliters) of 30 WT. HD OIL. DO NOT USE VARIABLE VISCOSITY OIL.
3. After performing the 5 hour service, change oil thereafter every 50 hours under normal operating conditions or at the end of each season.

NOTE
 Change oil every 25 hours if operating under adverse conditions.

(b) BRIGGS & STRATTON ENGINES (5 HP & 5.5 HP)

1. Tilt mower up on its back wheels to remove oil drain plug from underneath. See Figure 3.1.

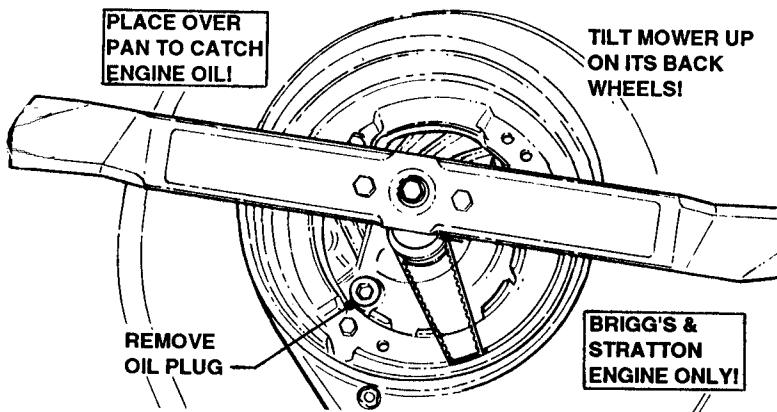

FIGURE 3.1

2. Lower mower back down onto its wheels and allow oil to drain completely.
3. Change oil every 50 hours, or as specified in engine manual. Check engine manual for type and amount of oil. Check oil level before each use.

(c) ENGINE (EVERY 25 HOURS) (KAWASAKI ENGINES ONLY)

1. Roll mower to flat area.
2. Put flat container (2 quart minimum capacity) under left side of mower deck.
3. Fashion a drain chute out of metal or cardboard as shown in Figure 3.2.
4. Loosen oil filler/dipstick cap.
5. Place drain chute beneath oil drain and remove plug.
6. Allow mower to drain completely.
7. Change oil every 25 hours, or as specified in engine manual. Check engine manual for type and amount of oil. Check oil level before each use.

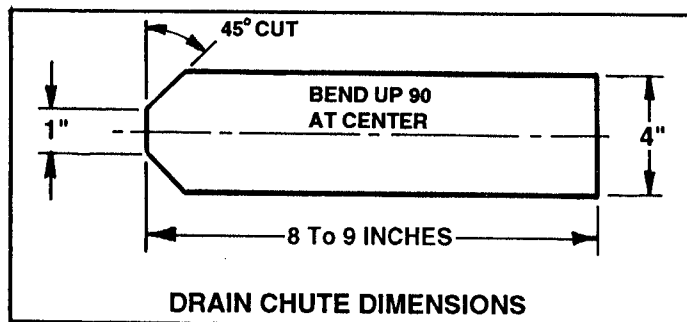
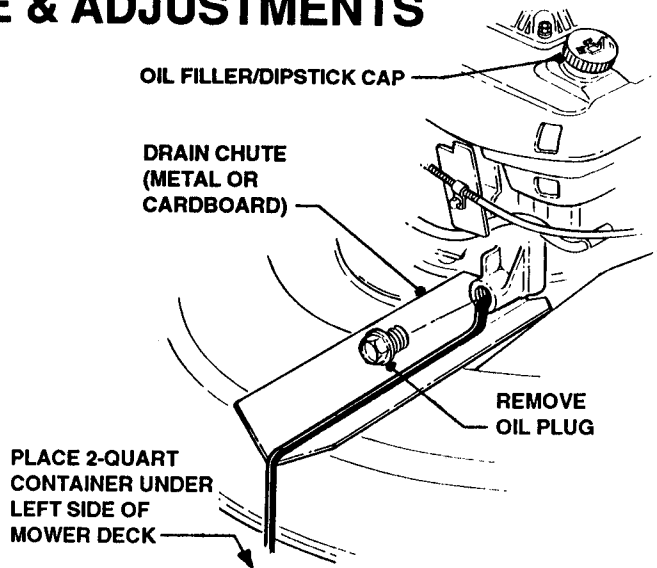

FIGURE 3.2

(d) TRANSMISSION (EVERY 25 HOURS)

1. Remove DRIVE COVER by removing two screws from top of cover. See Figure 3.3.
2. Inspect DRIVE BELTS for excessive wear, cracks, and splits.
3. Inspect DRIVE TIRE for wear or chunks of missing rubber.
4. Inspect SPRINGS and BEARINGS for signs of wear.

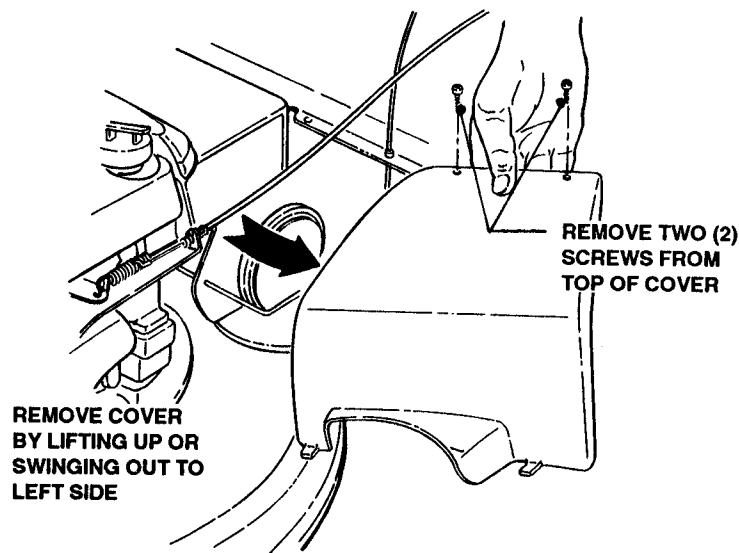

FIGURE 3.3

5. Remove transmission FILL PLUG. See Figure 3.4 on following page.

Section III - MAINTENANCE & ADJUSTMENTS

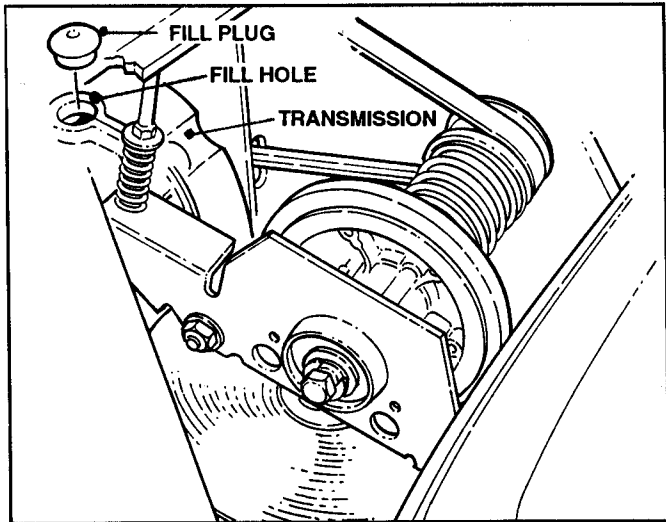
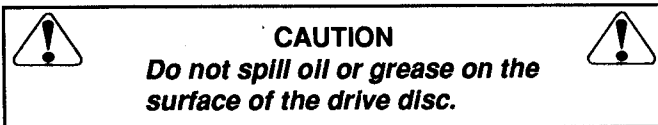

FIGURE 3.4

6. Look into FILL HOLE. If grease is NOT visible on the small gear (input shaft) directly below the fill hole while rolling the unit, add a small amount of SNAPPER "00" transmission grease to transmission (not over 2 fluid ounces).
7. Fill transmission to prescribed level. DO NOT overfill or it will cause leaks.



(e) WHEEL PIVOTS (EVERY 25 HOURS)

1. Lubricate arm pivot points between deck and arms on all wheels with 30 wt. motor oil. See Figure 3.5.

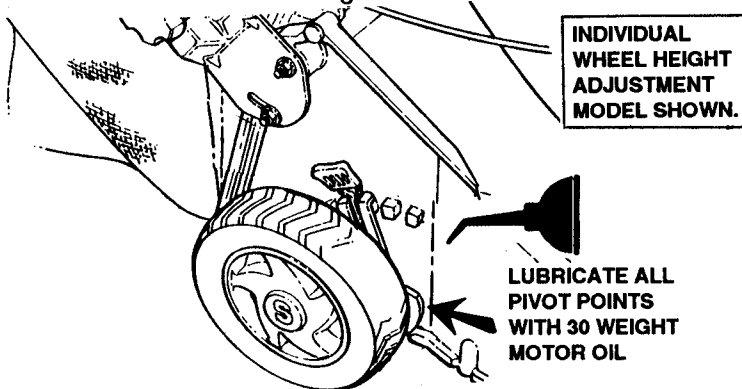

FIGURE 3.5

2. Lubricate handle pivot with Lithium grease. See Figure 3.6.

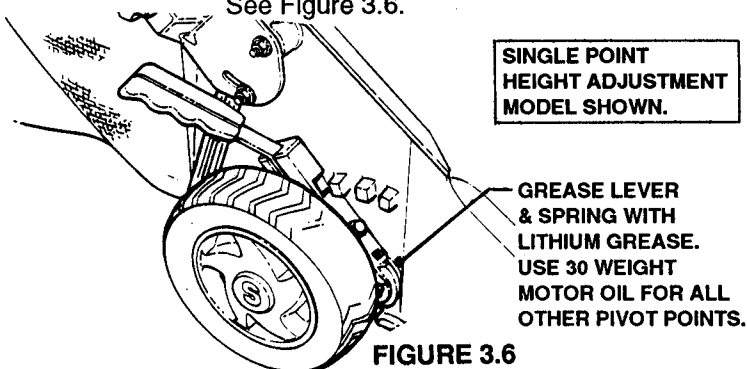

FIGURE 3.6

3.2 CUTTING BLADE SERVICE

1. Check at frequent intervals to make sure the Blade is securely tightened and that it is in good condition. Torque 25 to 45 FOOT POUNDS.
2. Replace Blade if badly chipped, bent, out of balance, or as soon as notch starts wearing in the tip between the flat surface and up-turned lift as shown in Figure 3.7. This type wear pattern occurs more rapidly in sandy soil.

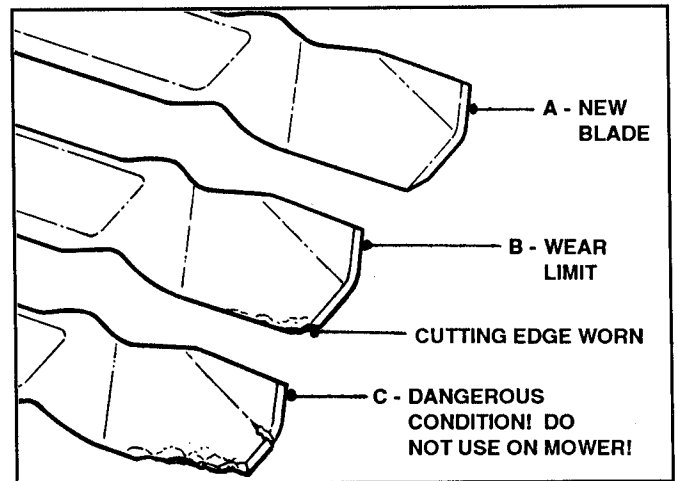
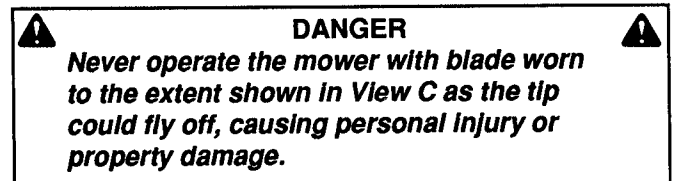

FIGURE 3.7

3. Sharpen Blade when the cutting edges become dull if the blade is in otherwise good condition. When dull, the grass cut ends will be ragged and usually turn brown soon after mowing. For best results, remove the blade and sharpen it on a grinding wheel at an angle of 22 to 28 degrees. The cutting surface should extend in about 2 1/2" from the tips. Check the blade after sharpening to determine that it is still balanced. It will cause excessive vibration if unbalanced. See Figure 3.8.

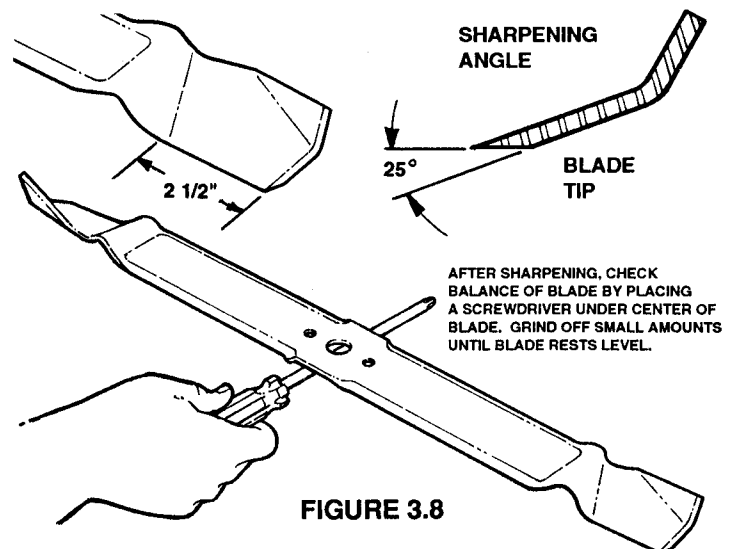

FIGURE 3.8

Section III - MAINTENANCE & ADJUSTMENTS

- Reinstall sharpened blade and components as shown in Figure 3.9.

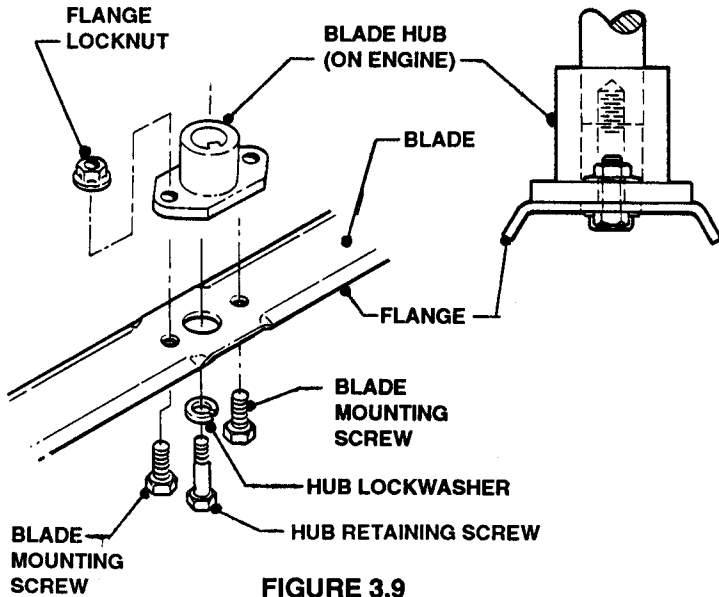

FIGURE 3.9

- Tighten the special blade retaining capscrew to 25 to 45 FOOT.POUNDS TORQUE.

3.3 DRIVE BELT ADJUSTMENT

During operation, if the mower will not power itself uphill or, while on level ground the mower drive seems to be slipping, then the mower drive belt probably needs adjusting. Proceed as follows:

- Push mower to level area.
- Release Wheel Drive Control Lever.
- Continue to hold Blade Control against handlebar and allow engine to keep running.
- Reach down with right hand and turn Drive Belt Tension Adjusting Wheel counterclockwise two (2) complete turns. See Figure 3.10.

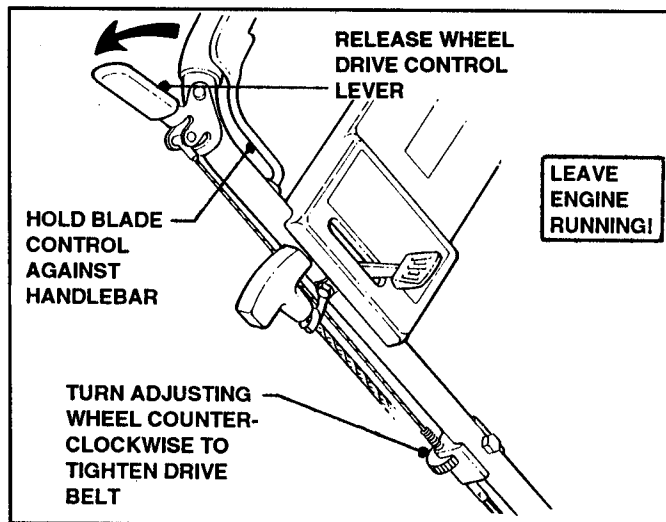

FIGURE 3.10

- Press Wheel Drive Control Lever against handlebar and allow mower to propel itself forward.
- If forward motion of mower is still unsatisfactory, turn Adjusting Wheel another turn.



3.4 DRIVEN DISC (RUBBER TIRE) CHECKING AND ADJUSTMENT PROCEDURES

(a) Preliminary check:

- STOP engine and disconnect the spark plug wire.

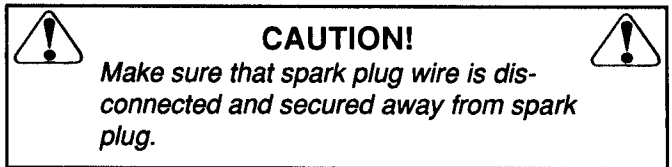

- Remove Drive Cover.
- Move Ground Speed Control Lever into highest (6th) speed setting.
- Manually pull the driven disc towards the left side of the mower until the spring is fully compressed (Refer to Figure 3.12).
- Check the dimension from the centerline of the rubber tire to the outside of the drive disc. It should measure 3/8". See Figure 3.11.

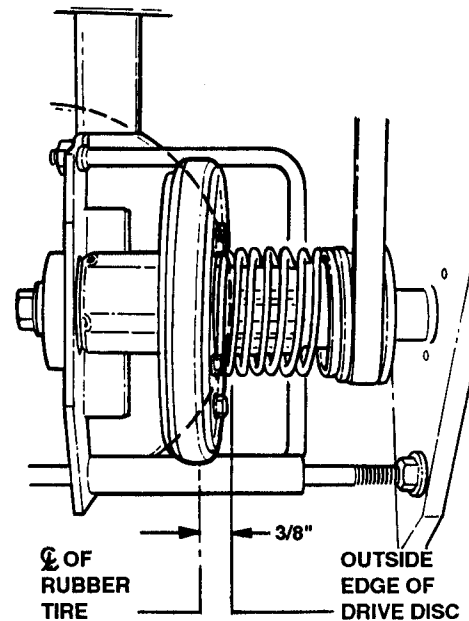

FIGURE 3.11

- If the centerline of the rubber tire is NOT 3/8" from the outer edge of the drive disc, adjust as follows:

Section III - MAINTENANCE & ADJUSTMENTS

(b) Adjustment Procedure:

1. Loosen the appropriate jam nut and, while the spring is still compressed, adjust the Ground Speed Control Cable until the Cable is under slight tension. See Figure 3.12.

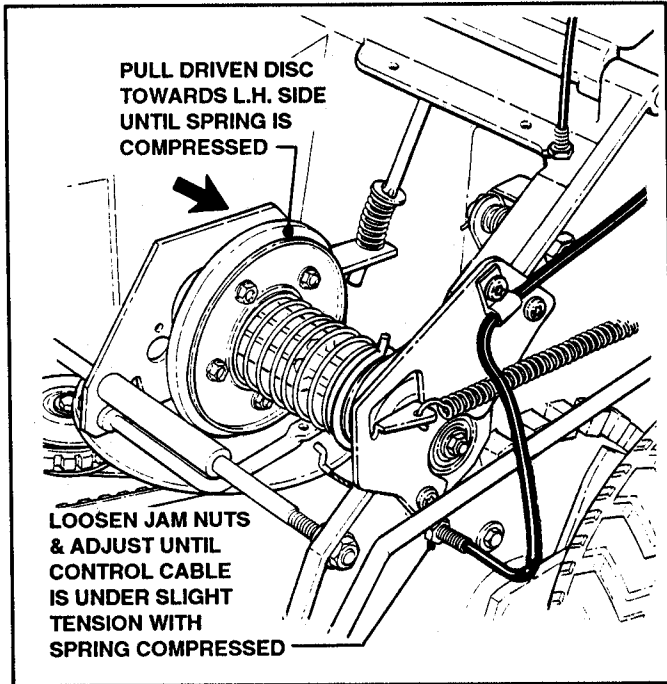

FIGURE 3.12

2. Continue adjustment of the Cable ("IN" or "OUT") until the centerline of the rubber tire is $\frac{3}{8}$ " from the outer edge of the drive disc.
3. Tighten jam-nuts.
4. Move Speed Control Lever to lowest (1st) speed setting (Control Cable should be taut - adjust if required).
5. Check position of rubber tire on drive disc; it should be close to, but not touching, the bolt head in the center of the drive disc.
6. Re-attach spark plug wire and start engine. Test adjustment by operating mower through all speed settings. Re-adjust if necessary.

3.5 DRIVEN POLY "V" BELT REPLACEMENT

The Driven Poly 'V' Belt should be inspected for signs of excessive wear, fraying, cracks, etc. If the Belt shows any of the above symptoms, it should be replaced as follows:

1. Stop engine.
2. Disconnect spark plug wire.
3. Remove belt cover.
4. Remove Ground Speed Control Cable as shown in Figure 3.13.

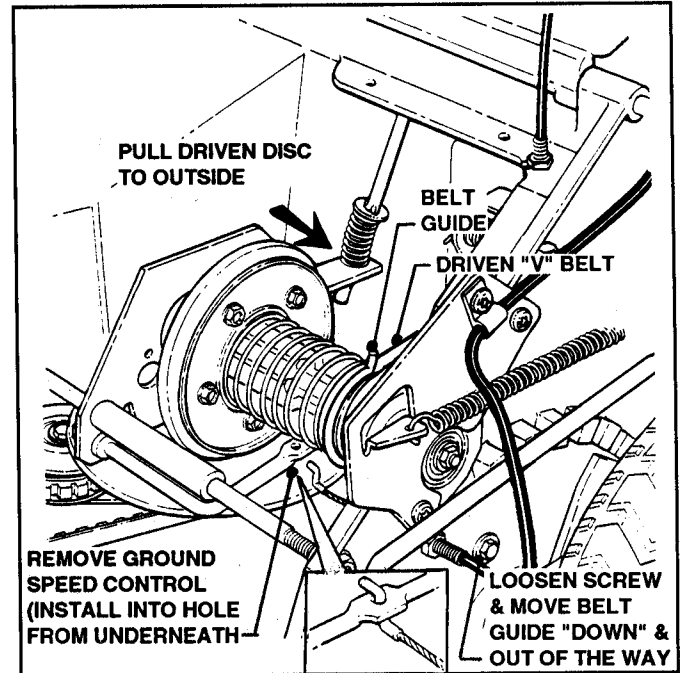

FIGURE 3.13

5. Loosen Belt Guide and move "DOWN" and out of the way (refer to Figure 3.13 above).
6. Remove retaining nut and flat washer from end of hex shaft. Next, remove flange lock nut as shown and remove lock nut from other end of same shaft found under deck. See Figure 3/14.

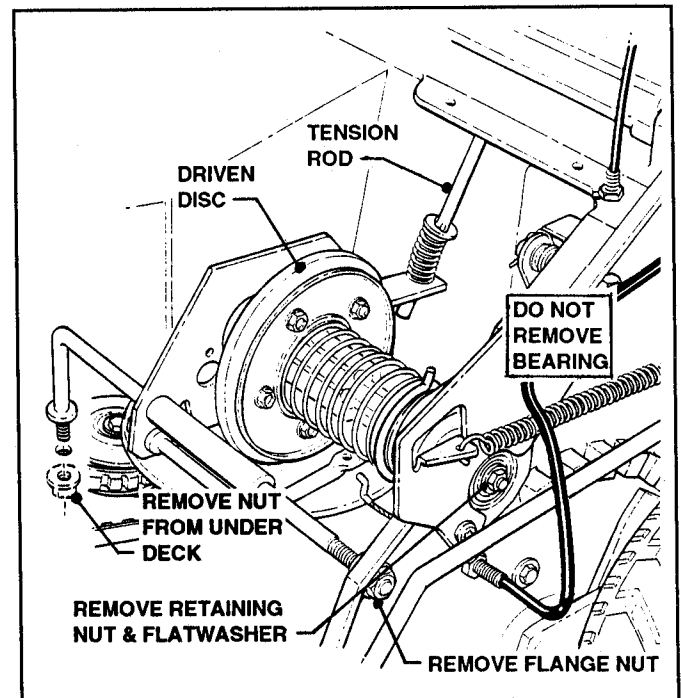

FIGURE 3.14

Section III - MAINTENANCE & ADJUSTMENTS

7. Push Driven Disc towards L.H. side of mower deck and remove Tension Rod by pressing down on rod and spring and pulling rod out from under deck. See Figure 3.15.

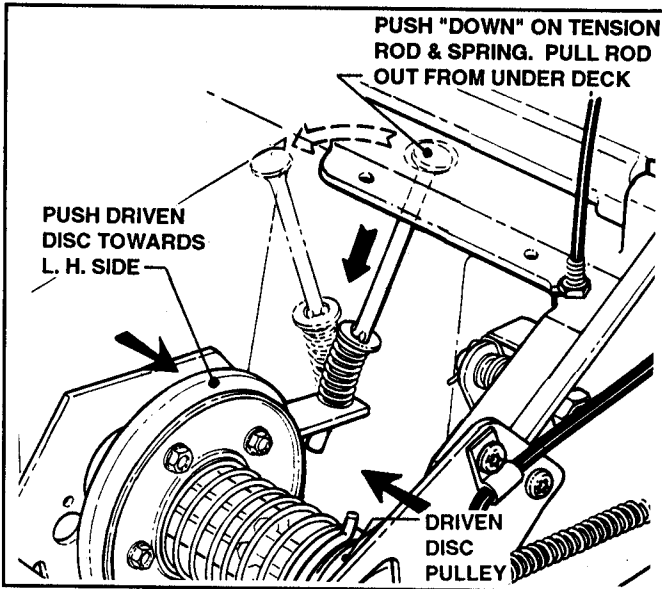

FIGURE 3.15

8. At this point, Driven Disc Assembly can be removed from the bearing in the mower housing by pressing inward on the Driven Disc Pulley until the shaft clears the bearing.
9. Lift up on the end of the shaft and remove the Poly "V" Belt from the pulley.
10. Release pressure on Idler Torsion Spring by prying out upper end of spring with screwdriver. See Figure 3.16.

NOTE!

Mark location of Idler Pulley in slotted hole before removal. Replace in same location.

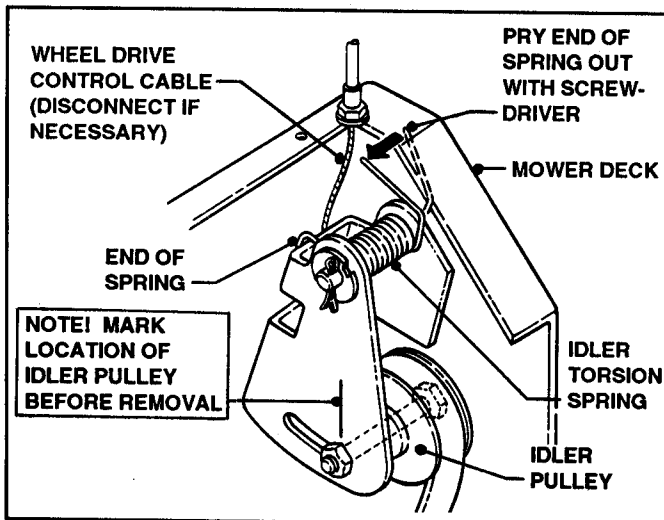

FIGURE 3.16

NOTE!

In following "DRIVEN POLY "V" BELT REPLACEMENT" instructions, omit that part dealing with idler removal.

11. Remove Cotter Pin.
12. Remove Idler Assembly from mounting post.
13. Remove Idler Pulley from bracket (MARK IDLER LOCATION!). See Figure 3.17.
14. Remove and replace Poly "V" Drive Belt.
15. Reassemble Idler Assembly in reverse order of above.

EXTREMELY IMPORTANT

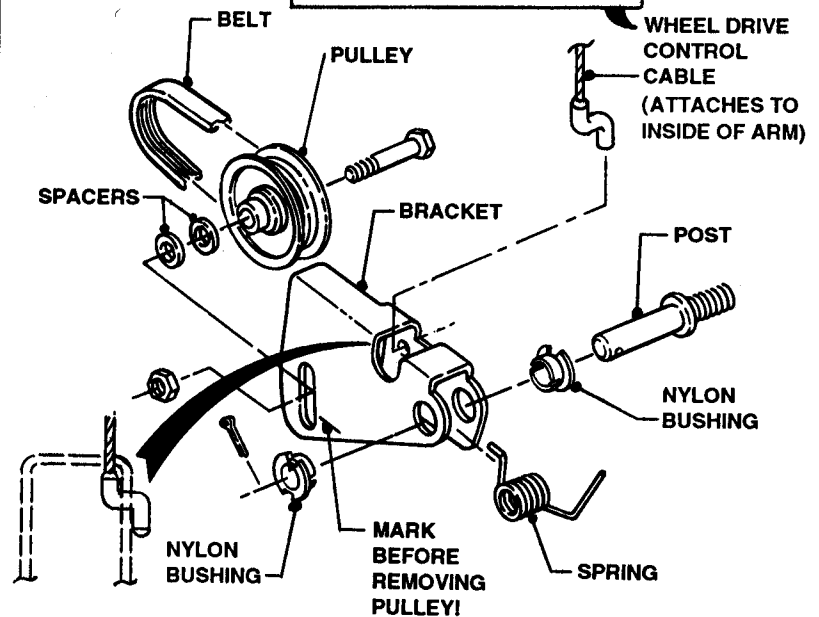

FIGURE 3.17

16. Place Poly "V" Drive Belt around Driven Disc Pulley.
17. Reinstall Driven Disc Assembly in reverse order of removal. See Figure 3.18 for installing the Guide Rod and adjustment of the Wheel Drive Control Cable.

NOTE!

See Page 12 for Figure 3.18.

Section III - MAINTENANCE & ADJUSTMENTS

IMPORTANT NOTE!

- A. When reinstalling the Driven Disc Assembly, install the Guide Rod as shown below in Figure 3.18.
- B. Before re-attaching Wheel Drive Control Cable, (refer to Figure 3.16), the Adjusting Wheel should be turned clockwise to lengthen the Cable for easier installation. After the Cable has been attached, rotate the Adjusting Wheel counter-clockwise until the Drive Belt has enough tension to power the mower. **DO NOT OVERTENSION BELT!**

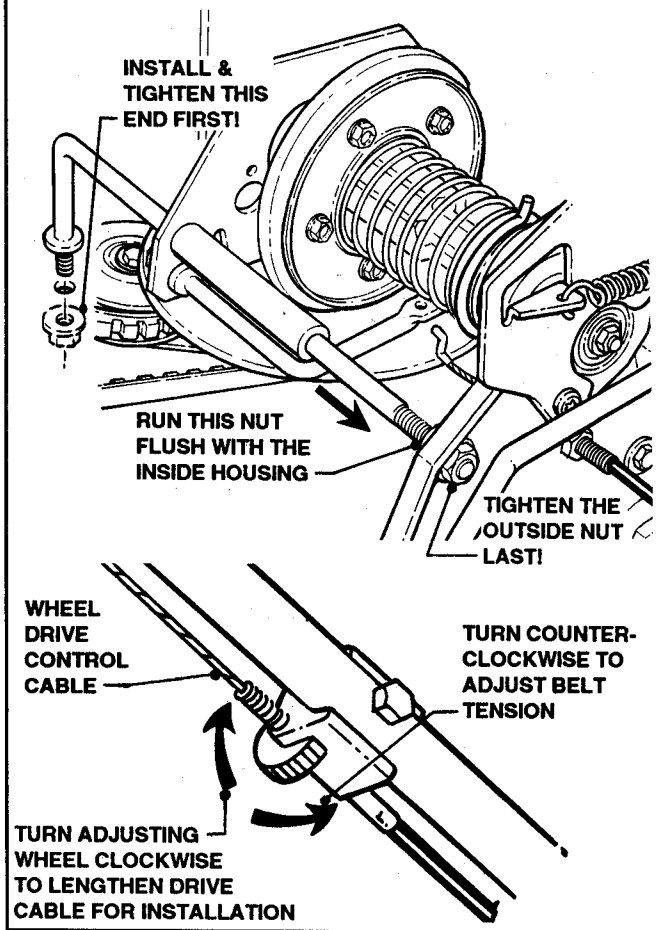

FIGURE 3.18

3.6 DRIVE DISC (Rubber Tire) REPLACEMENT

If the rubber tire on the Driven Disc is badly chunked or worn down to within 1/16" of the metal rim of the Driven Disc, it must be replaced. Proceed as follows:

1. Stop engine.
2. Disconnect spark plug wire.
3. Remove Driven Disc Assembly as outlined in "DRIVEN POLY "V" BELT REPLACEMENT".

NOTE!

In following "DRIVEN POLY "V" BELT REPLACEMENT" instructions, omit that part dealing with Idler removal.

4. Remove the five machine screws and plate securing the Driven Disc rubber ring to the hub. See Figure 3.19.

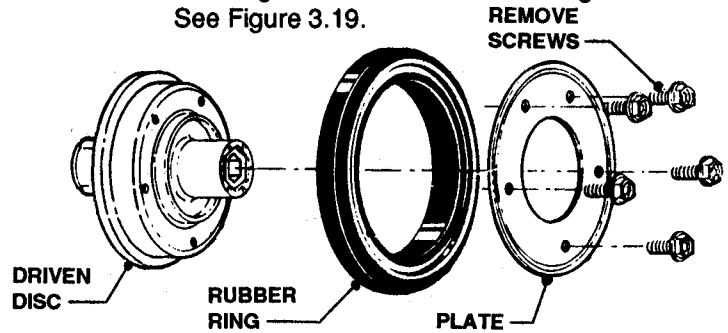

FIGURE 3.19

5. Install new rubber ring.
6. Reassemble Driven Disc.
7. Reassemble all components in reverse order.

NOTE!

DO NOT disassemble Driven Disc Assembly by removing press-on washer located on end of hex shaft. Follow instructions below in "DRIVEN DISC ASSEMBLY AND BEARING REPLACEMENT" for disassembly.

3.7 DRIVEN DISC ASSEMBLY AND/OR BEARING REPLACEMENT

1. Remove Driven Disc Assembly as outlined in "DRIVEN POLY "V" BELT REPLACEMENT".
2. Stand Driven Disc Assembly on end of work bench and press down on yoke frame until circlip fastener can be removed. Release downward pressure slowly to prevent injury. See Figure 3.20.

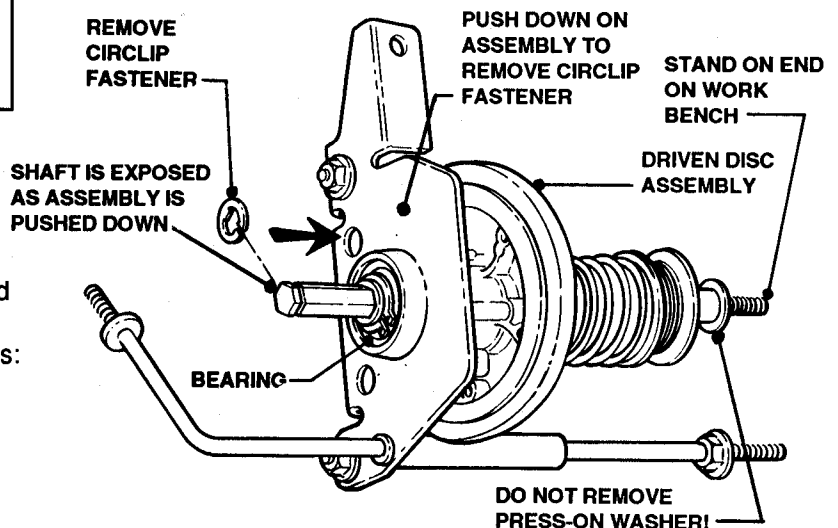

FIGURE 3.20

Section III - MAINTENANCE & ADJUSTMENTS



3. Remove hex shaft from bearing and Driven Disc Assembly.
4. Remove retaining ring from end of Hub Assembly. See Figure 3.21.
5. Remove Hub Assembly from bearing.
6. Replace worn or broken part or bearing.
7. Reassemble all components in reverse order.

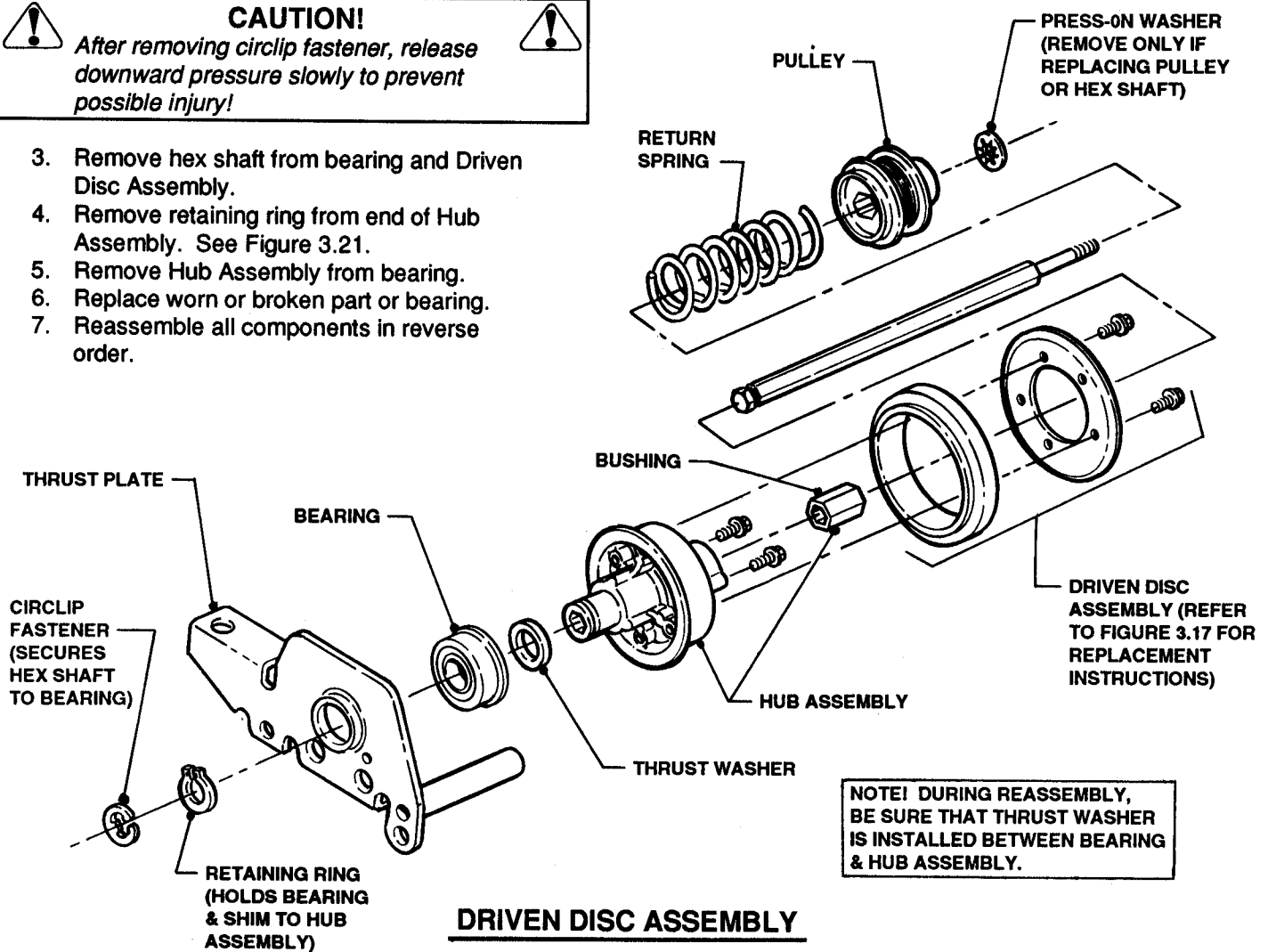

FIGURE 3.21

3.8 DRIVE "V" BELT REPLACEMENT

The Drive "V" Belt is self-adjusting. It also should be inspected at the beginning and end of each mowing season for signs of wear, fraying, cracks, etc. If the Blade Drive Belt shows any signs of excessive wear, it should be replaced as follows:

1. Remove Driven Disc Assembly per steps 1 through 10 of 3.5, DRIVEN POLY "V" BELT REPLACEMENT.
2. Remove Driven Disc Assembly from mower.
3. Rotate Driven Disc Assembly "UP" and slide to the inside as far as possible.
4. Tilt mower up on its right-hand side.
5. Remove mower blade.
6. Using a™ TORX T-50 bit to hold the inside of the Drive Disc bolt, remove the nut and washer from underside of mower with 11/16" socket. See Figure 3.22.

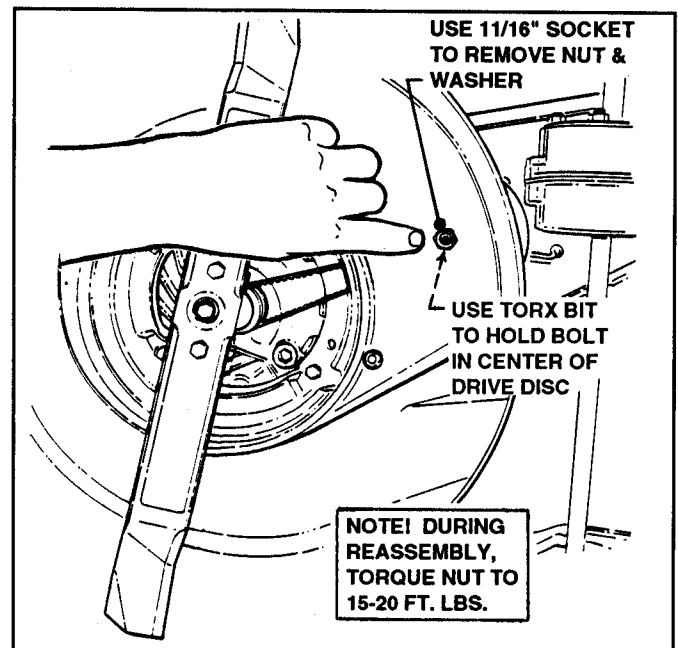

FIGURE 3.22

Section III - MAINTENANCE & ADJUSTMENTS

- Remove Drive Disc bolt from top side of mower deck. See Figure 3.21.
- Lift Drive Disc "UP" and away from mower deck while removing Drive "V" Belt.

NOTE

If Idler and Idler Arm separate from deck, reseat both back into position. See Figure 3.23.

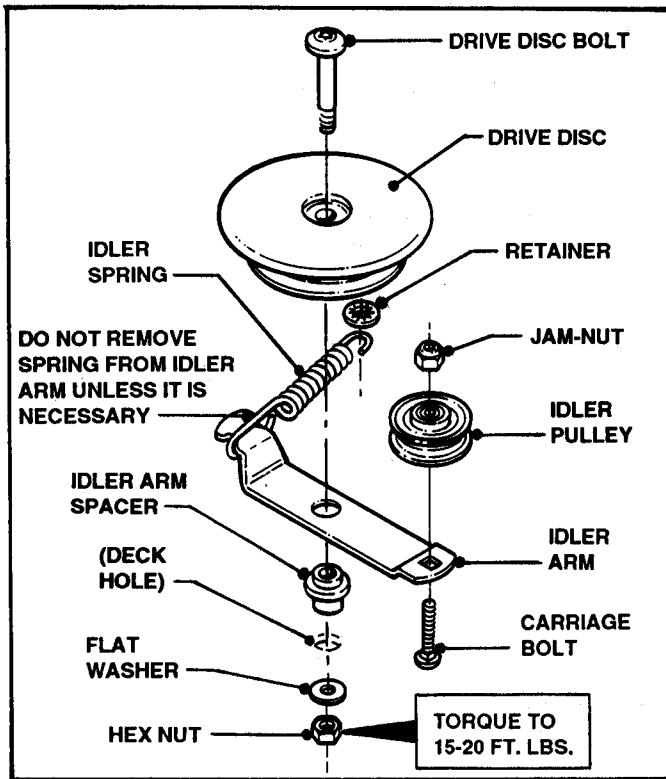

FIGURE 3.23

- Install new belt around Drive Disc Pulley, then feed other end through deck opening and around Blade Pulley. See Figure 3.24.

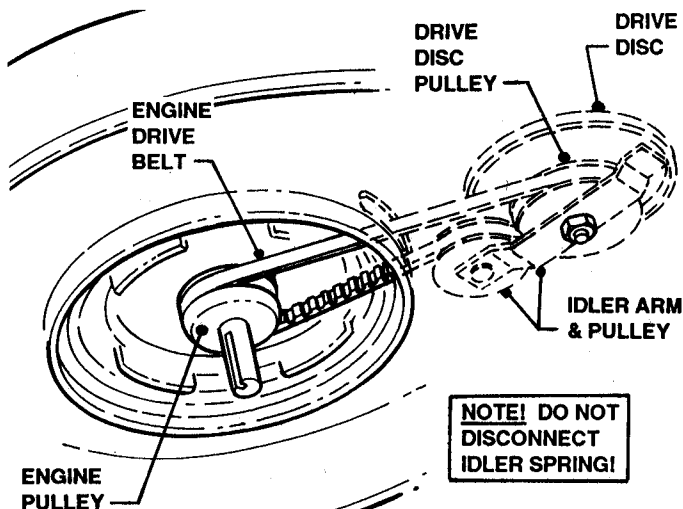

FIGURE 3.24

- Reinstall Drive Disc and Idler to mower deck.
- Reinstall all components in reverse order.

3.9 SPEED SELECTOR ASSEMBLY

If Speed Control Lever will not stay in selected position, then the "rooster comb" quadrant may be badly worn or the lever may be faulty. If this is the case, the Speed Selector should be replaced as an assembly as follows:

- Place Speed Control Lever in No. 3 position.
- Remove nuts and washers from inside of handlebar.
- Push Selector Assembly off bolts and remove by pulling handle down through slot. See Figure 3.25.

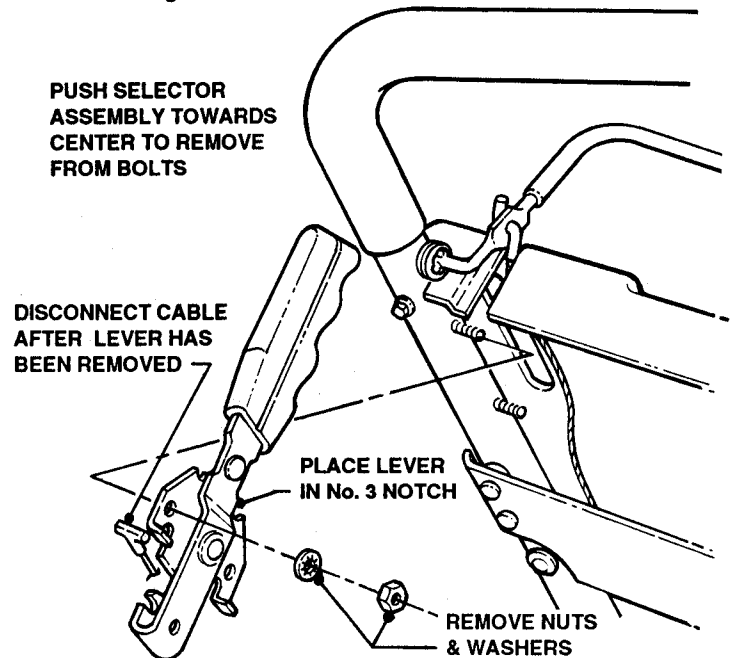

FIGURE 3.25

- Disconnect Speed Control Cable.
- Install new Selector Assembly in reverse order.

3.10 LINKAGE ASSEMBLY - SINGLE POINT HEIGHT OF CUT

- Figure 3.26 (on Page 15) shows the components which make up the linkage of the Single Point Height of Cut Walk-Behind Mower.
- Most of the rear linkage must be removed to replace the trail shield or transmission and, when reassembling the linkage, care must be taken to reposition the fasteners, spring, washers and other components exactly as shown in Figure 3.26.
- All pivot points (pins, holes and pivot arms) are subject to wear due to general use. Symptoms of wear will be loose motion, wobbling wheels or inability to maintain even cutting height. Replace parts as required.

Section III - MAINTENANCE & ADJUSTMENTS

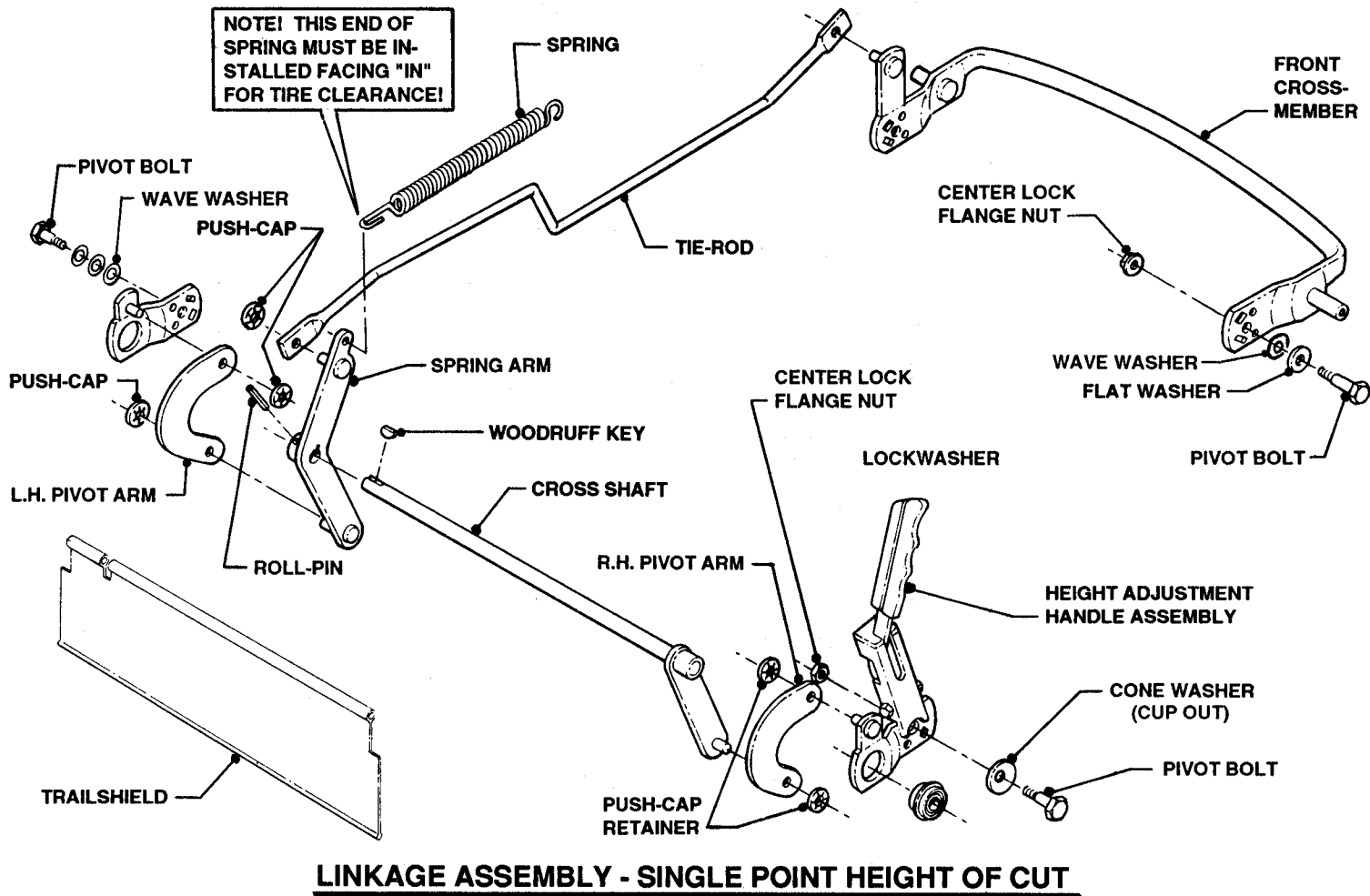

FIGURE 3.26

3.11 TRAIL SHIELD & CROSS SHAFT REMOVAL

1. Place mower on flat surface and remove rear wheels.
2. Set Height Adjusting Handle at highest position.
3. Remove spring from bracket (front). See Figure 3.27.

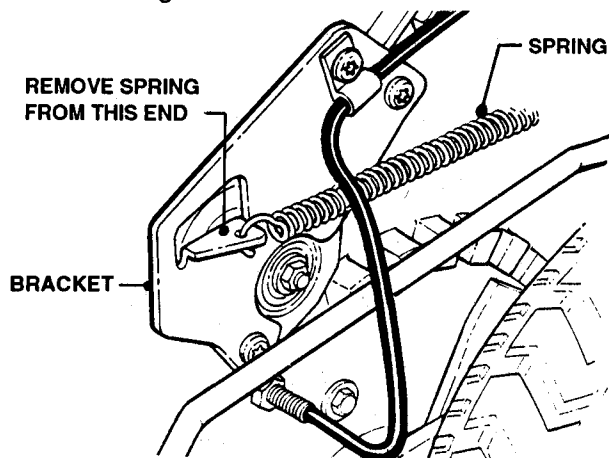

FIGURE 3.27

4. Remove the push cap retainers from the L.H. side and remove pivot arm.
5. Drive out roll pin and remove spring arm.
6. Remove woodruff key from cross shaft.
7. Remove the upper push cap retainer from the R.H. side.
8. Rotate R.H. pivot arm down and forward out of the way.
9. Remove cross shaft (trail shield rod) from R.H. side.
10. Replace worn component(s) and reassemble in reverse order.

3.12 TRANSMISSION REMOVAL (Single Point Height of Cut)

1. Follow Steps 1 through 9 of "TRAIL SHIELD & CROSS SHAFT REMOVAL".
2. Separate rear wheel brackets from deck by removing shoulder bolts.
3. Slip Poly "V" Belt off Transmission Input Pulley.
4. Slide wheel brackets off ends of axle.
5. Remove transmission from mower.
6. Replace transmission by reversing removal procedure.

Section IV - TROUBLESHOOTING

PROBLEM	POSSIBLE CAUSE(S) AND PROBABLE REMEDY
WILL NOT START	<ol style="list-style-type: none"> 1. IMPROPER CHOKING <ol style="list-style-type: none"> a. Throttle Control left in stop or run position. Move knob to choke or start. b. Throttle Cable setting incorrect. Reset to correspond to knob positions. 2. NOT GETTING FUEL <ol style="list-style-type: none"> a. Fuel tank empty. Replenish fuel supply. b. Fuel line clogged. Clean out. c. Carburetor faulty or gummed up. Carburetor reconditioning required. 3. NO IGNITION SPARK <ol style="list-style-type: none"> a. Ignition lead loose or off spark plug. Reconnect lead. b. Interlock preventing start-up due to operator's presence control (OPC) not held against handle. Hold OPC against handle. c. Spark plug electrodes fouled by deposits, oil or fuel. Remove plug and service or replace. 4. OTHER CAUSES <ol style="list-style-type: none"> a. Not cranking due to dead battery on electric start models. Recharge or replace. b. Interlock faulty. Test and replace assembly as required.
STARTS HARD	<ol style="list-style-type: none"> 1. FUEL RELATED CAUSES <ol style="list-style-type: none"> a. Throttle Control in wrong position causing too much choking when engine hot or too little when cold. Reposition knob. b. Water or other impurities in fuel. Dump fuel and replenish with clean, fresh supply. c. Air cleaner clogged causing rich mixture. Service element. 2. OTHER CAUSES <ol style="list-style-type: none"> a. Dense grass restricting free rotation of blade as engine cranked. Move mower to clear area. b. Weak ignition spark. Check for and correct loose connections, poor contacts and faulty plug. c. Carburetor malfunctioning. Reset to specifications or have reconditioned. d. Battery weak causing too low cranking speed. Recharge battery.
STOPS SUDDENLY	<ol style="list-style-type: none"> 1. FUEL RELATED CAUSES <ol style="list-style-type: none"> a. Fuel run dry. Refill tank after proper cooling off period. b. Carburetor main fuel needle vibrated closed. Reset to specifications. 2. OTHER CAUSES <ol style="list-style-type: none"> a. Blade jammed by solid object or accumulation of grass. Disconnect spark plug lead and unclog. b. Ignition lead wire disconnected or grounded by branch, shrub, etc. Reconnect. c. Interlock stops operation due to malfunction. Repair or replace. d. Engine stops due to overheating or internal malfunction. Locate and correct cause.
VIBRATES EXCESSIVELY	<ol style="list-style-type: none"> 1. CUTTING BLADE RELATED <ol style="list-style-type: none"> a. Blade loose. Retighten retaining capscrew. b. Blade improperly installed on hub. Install blade correctly. c. Blade out of balance due to impact damage. Replace blade. 2. ENGINE RELATED <ol style="list-style-type: none"> a. Engine mounting bolts loose or missing. Install replacements and/or retighten loose bolts. b. Engine crankshaft bent. See engine dealer for straightening or replacement.

Section IV - TROUBLESHOOTING

PROBLEM	POSSIBLE CAUSE(S) AND PROBABLE REMEDY
MOWING/BAGGING PROBLEMS	<ol style="list-style-type: none"> 1. CUTS POORLY. <ol style="list-style-type: none"> a. Wheels set lower on one side. Reposition to height setting. b. Blade cutting edges worn dull. Sharpen or replace. c. Ground speed too fast and/or engine speed too low for conditions. Reset speed. d. Blade is installed upside-down. Install blade correctly. 2. BAGS IMPROPERLY <ol style="list-style-type: none"> a. Grass bag too full or pores clogged. Thoroughly empty and clean bag. b. Cutting height set too low for conditions. Raise height. c. Engine speed set too low for bagging. Increase engine speed and/or decrease ground speed. 3. DRIVE/DRIVEN DISC ASSEMBLY RELATED <ol style="list-style-type: none"> a. Flat spot on rubber drive disc. Replace rubber drive disc. b. Hex shaft bearing worn. Replace bearing.
MOWER PUSHES HARD	<ol style="list-style-type: none"> 1. COMMON CAUSES <ol style="list-style-type: none"> a. Excessive weight due to full grass bag. Empty bag. b. Cutting height set too low in dense grass. Raise height. c. Wheel bearings sticking. Lubricate and/or replace bearings. d. Drive belt not fully disengaged. Check belt guides on differential and pulley.
SLIPS INTO OTHER SPEED SETTINGS	<ol style="list-style-type: none"> 1. DRIVE DISC MISALIGNED <ol style="list-style-type: none"> a. Idler arm spacer is worn. Replace spacer. b. Drive Disc TORX screw is loose. Torque to 15-20 Ft. Lbs. 2. SPEED CONTROL LEVER WON'T REMAIN AT SELECTED SPEED <ol style="list-style-type: none"> a. Indents in speed control quadrant worn. Replace assembly. b. Handle pin worn. Replace assembly.
SPEED CONTROL LEVER CANNOT BE SET AT HIGHEST (6th) SPEED	<ol style="list-style-type: none"> 1. DRIVE DISC (RUBBER TIRE) OUT OF ADJUSTMENT <ol style="list-style-type: none"> a. Speed Control Cable out of adjustment. Adjust Cable. b. Speed Control Assembly worn. Replace Assembly.
WILL NOT PULL PROPERLY WITH WHEEL DRIVE CONTROL ENGAGED	<ol style="list-style-type: none"> 1. BELT SLIPPAGE <ol style="list-style-type: none"> a. Check for excessive wear on Drive and Poly V-Belts. Replace worn Belts. 2. DRIVE/DRIVEN DISC RELATED <ol style="list-style-type: none"> a. Check for and remove grease or oil from surface of drive disc. b. Rubber driven disc worn or chunked. Replace driven disc. c. Drive spring broken or unhooked. Replace or reconnect spring. d. Drive disc grooved. Replace disc. e. Bearing damaged in driven disc. Replace disc. 3. HEX SHAFT RELATED <ol style="list-style-type: none"> a. Hex shaft retaining locknut loose. Retighten locknut. b. Hex shaft worn round. Replace hex shaft. c. Hex shaft bearing worn out. Replace bearing. 4. DIFFERENTIAL RELATED <ol style="list-style-type: none"> a. Differential input shaft worn. Disassemble transmission and replace shaft. b. Differential gear damage. Recondition transmission. c. Differential gears or spacers missing. Install missing parts. 5. OTHER CAUSES <ol style="list-style-type: none"> a. Deck Idler Assembly broken or unhooked. Replace spring or reconnect if not broken. b. Bushings turning inside driven disc hub. Replace disc.

Section V - OVERHAUL & REPAIR

5.1 TRANSMISSION TESTS - SELF-PROPELLED MODELS

A. If the Drive Wheels will not pull mower properly with Clutch engaged, the cause may NOT be a faulty transmission. (Refer to TROUBLE-SHOOTING Guide in Section III for possible causes).

B. TO TEST TRANSMISSION

1. Raise rear of mower and place a block under deck to allow rear wheels to turn freely.
2. Turn Input Pulley on transmission and observe rear wheels.
 - (a) Both wheels should turn in **same direction** or wheel with least resistance will turn as the Pulley is turned.
3. Turn both rear wheels in same direction and observe Input Pulley.
 - (a) Pulley should turn when wheels are turned.
4. Hold Input Pulley to prevent it from turning.
 - (a) Turn one of the rear wheels and observe other wheel.
 - (b) The free wheel should rotate in the **opposite direction** of the wheel being turned.
5. Hold Input Pulley and one wheel to prevent them from turning.
 - (a) Try turning other wheel. **No movement** should occur.
 - (b) If movement occurs, axle gears may be slipping on splines around axles.
6. If the desired results are NOT obtained in tests:
 - (a) Problem may be internal damage such as broken or missing pinion or axle gears.
 - (b) Transmission should either be replaced as a unit or overhauled.

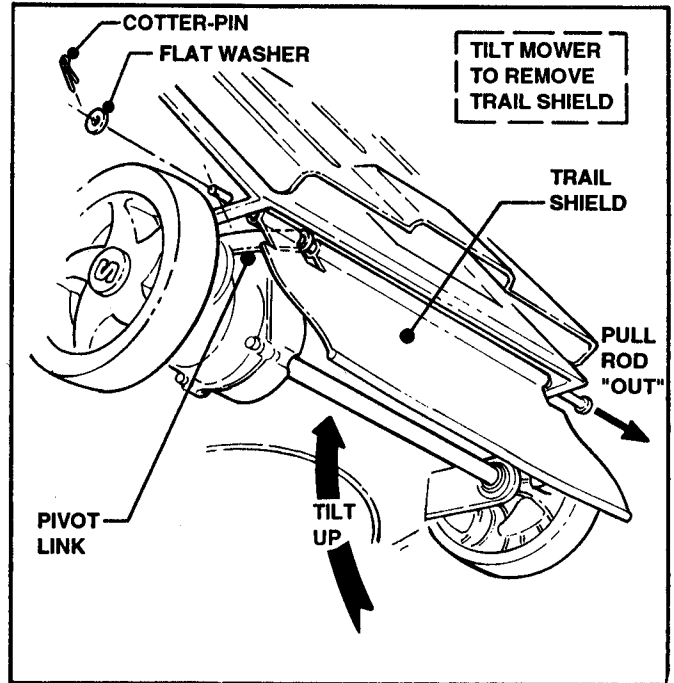

FIGURE 5.1

3. Slip Poly "V" Belt off Input Pulley.
4. Place blocks under rear of deck and remove both rear wheels.
5. Separate rear Wheel Brackets from deck by removing shoulder bolts. See Figure 5.2.

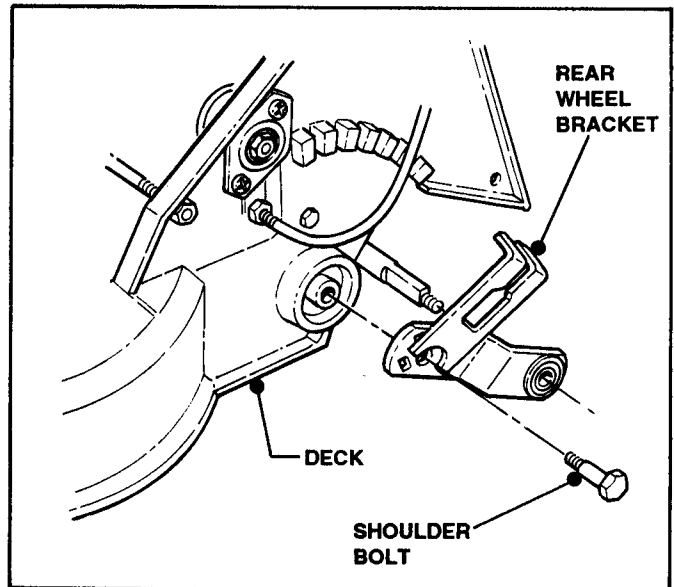

FIGURE 5.2

5.2 TRANSMISSION REMOVAL

- A. Proceed as follows"
1. Move Rear Wheel Adjusters to highest position.
 2. Remove Trail Shield to free Pivot Link. See Figure 5.1.

6. Slide Wheel Brackets off ends of axle.
7. Remove Transmission from mower.
8. Replace Transmission by reversing removal procedure.

Section V - OVERHAUL & REPAIR

5.3 TRANSMISSION DISASSEMBLY

NOTE!

Carefully inspect parts as they are disassembled and replace damaged or worn parts.

- A. Place Unit on work bench and proceed as follows:
1. Remove Poly "V" Pulley and Differential Bracket. See Figure 5.3.

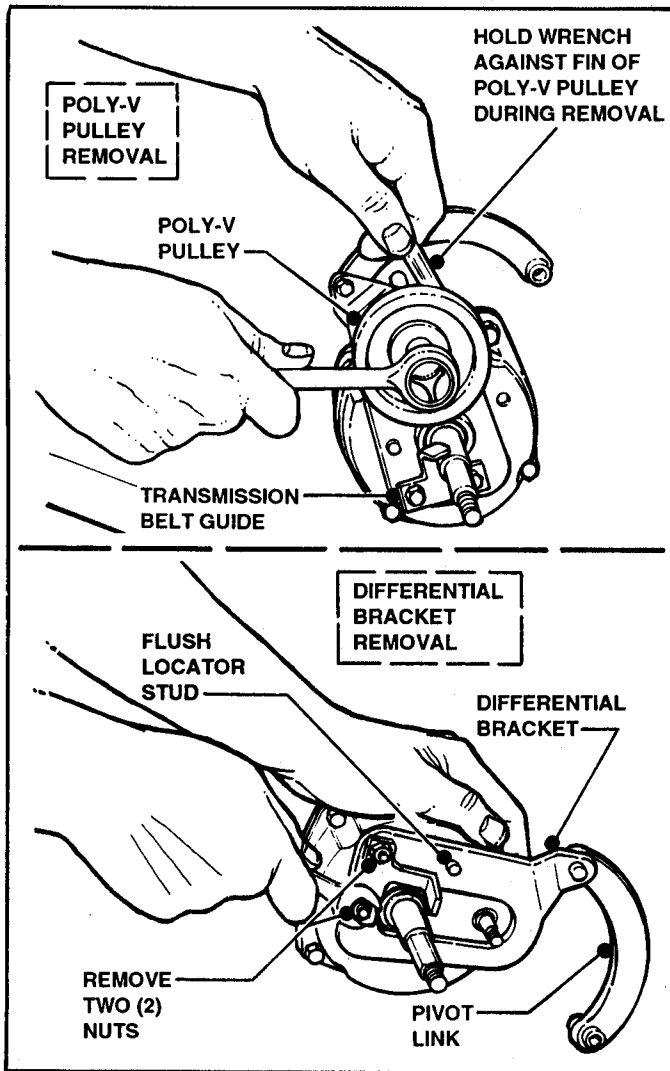

FIGURE 5.3

1. Remove lube plug and housing capscrews.
2. Separate housing halves and let grease drain into suitable container. See Figure 5.4.

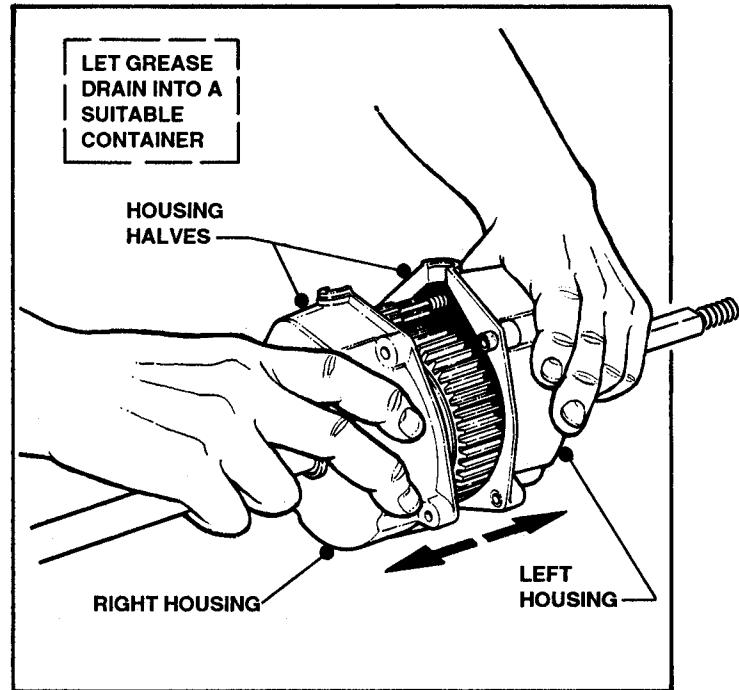

FIGURE 5.4

4. Remove left housing half from axle.
5. Pull input shaft with bearing attached out of housing.
6. Remove right housing half from axle.

B. Bull Gear Disassembly:

1. Remove the four plate capscrews.
2. Disassemble bull gear and discard the components found to be worn or damaged. See Figure 5.5.

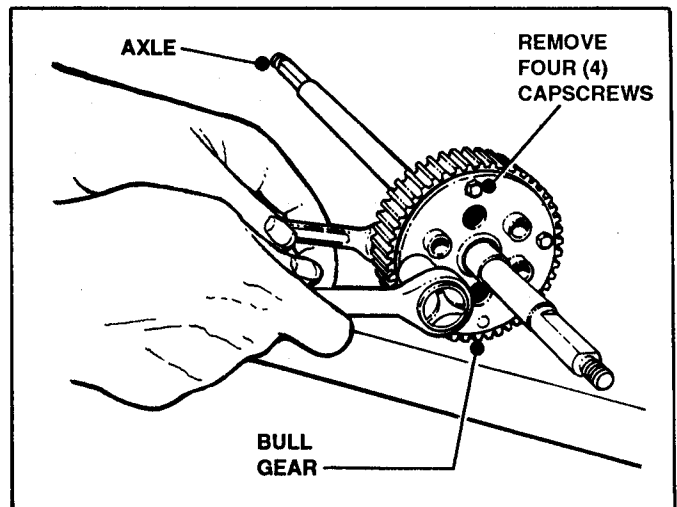
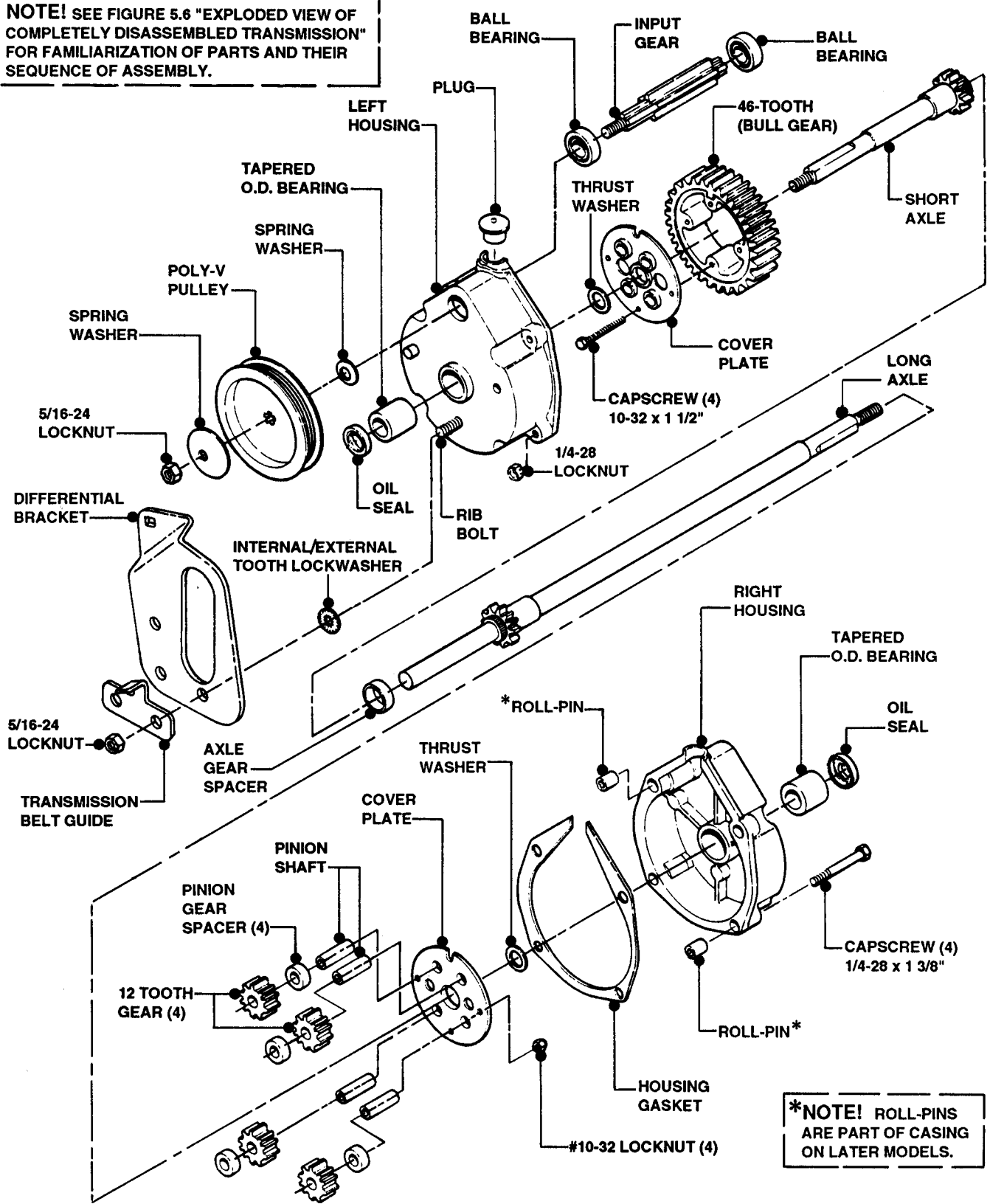

FIGURE 5.5

Section V - OVERHAUL & REPAIR

NOTE! SEE FIGURE 5.6 "EXPLODED VIEW OF COMPLETELY DISASSEMBLED TRANSMISSION" FOR FAMILIARIZATION OF PARTS AND THEIR SEQUENCE OF ASSEMBLY.



***NOTE!** ROLL-PINS ARE PART OF CASING ON LATER MODELS.

EXPLODED VIEW OF COMPLETELY DISASSEMBLED TRANSMISSION

FIGURE 5.6

Section V - OVERHAUL & REPAIR

5.4 TRANSMISSION REBUILDING

A. BULL GEAR

1. Assemble bull gear in hand or clamp a 2" x 4" board (about 2' long) to a work bench.
2. Drill a 1" hole through board if using. See Figure 5.7.

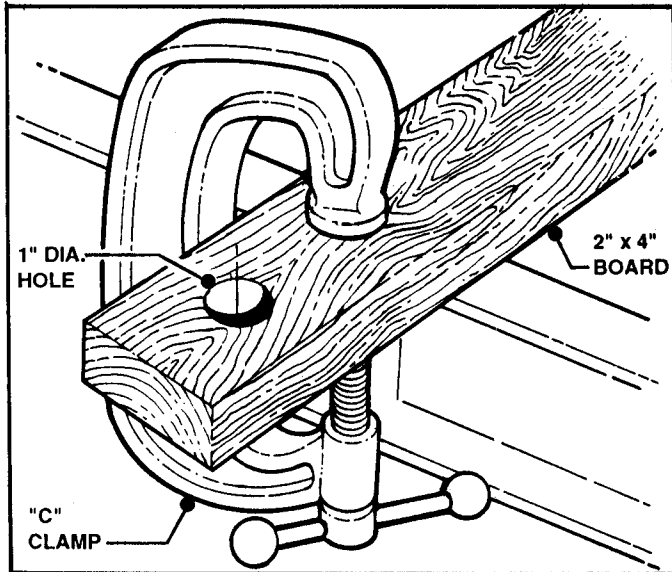

FIGURE 5.7

NOTE:

In rebuilding the bull gear, use parts from Kit No. 6-0337 and axles from old transmission, or individual parts.

3. If reassembling in hand, insert two of the 1 1/2" long capscrews in one of the cover plates and hold in hand with screws pointing up. If using the 2 x 4, install all four capscrews and place plate over hole drilled in the board. See Figure 5.8.

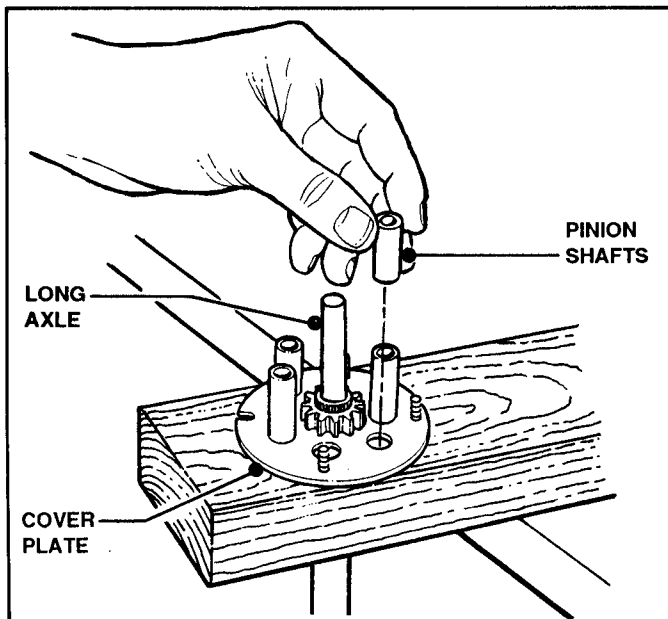

FIGURE 5.8

4. Insert long axle through center hole in plate with pin facing up. Refer to Figure 5.8.
5. Lightly grease the four pinion shafts, then install in cover plate. Refer to Figure 5.8.
6. Install pinion gears and spacers on shafts next. These must be staggered.
7. On shaft indicated as number 1 in Figure 5.9, install gear first, then spacer.

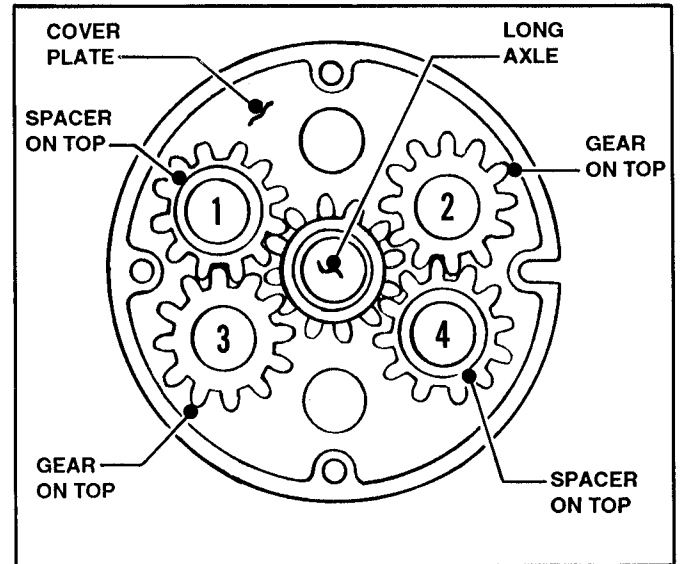

FIGURE 5.9

8. On adjacent shaft (number 2), install spacer first, then gear. When properly positioned, gear-spacer arrangement will be opposite side-to-side and the same diagonally as shown in Figure 5.9.
9. Install the axle gear spacer next to long axle gear around flared portion of axle. See Figure 5.10.

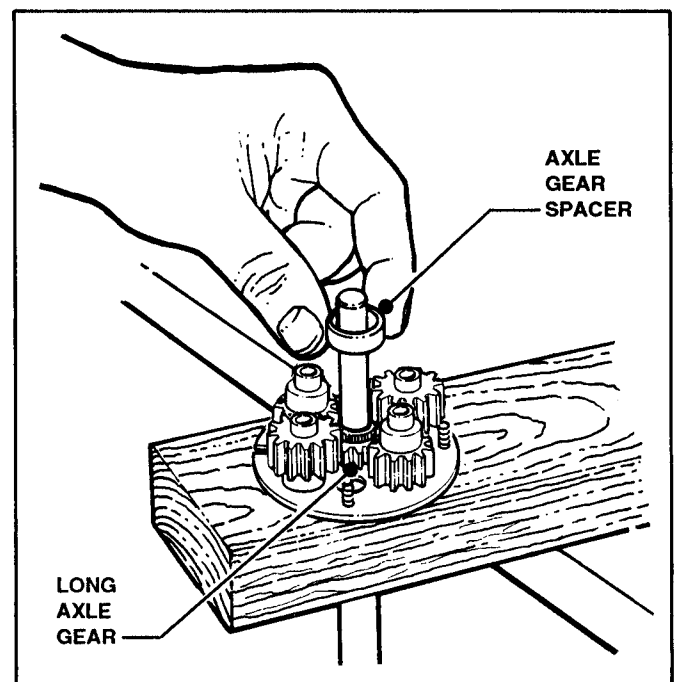

FIGURE 5.10

Section V - OVERHAUL & REPAIR

- Align raised portion of Bull Gear over matching slot in Cover Plate on the board. See Figure 5.11.

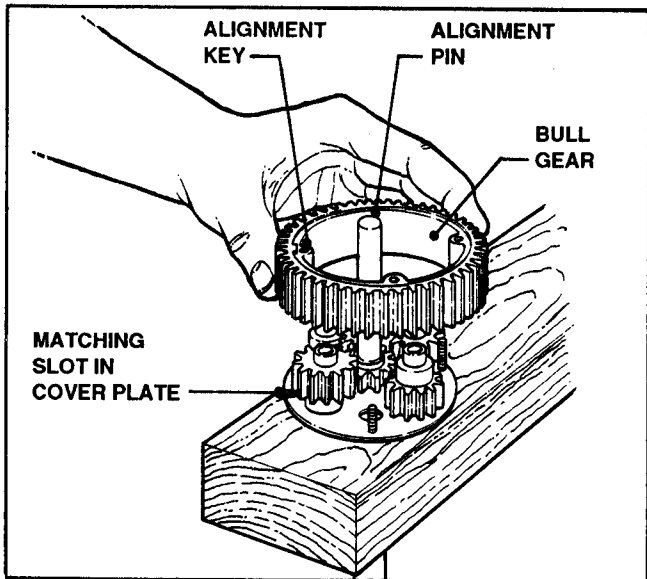

FIGURE 5.11

- Install Gear on Plate.
- Pre-lubricate Alignment Pin portion of long axle.
- Slip Short Axle onto Pin. See Figure 5.12.

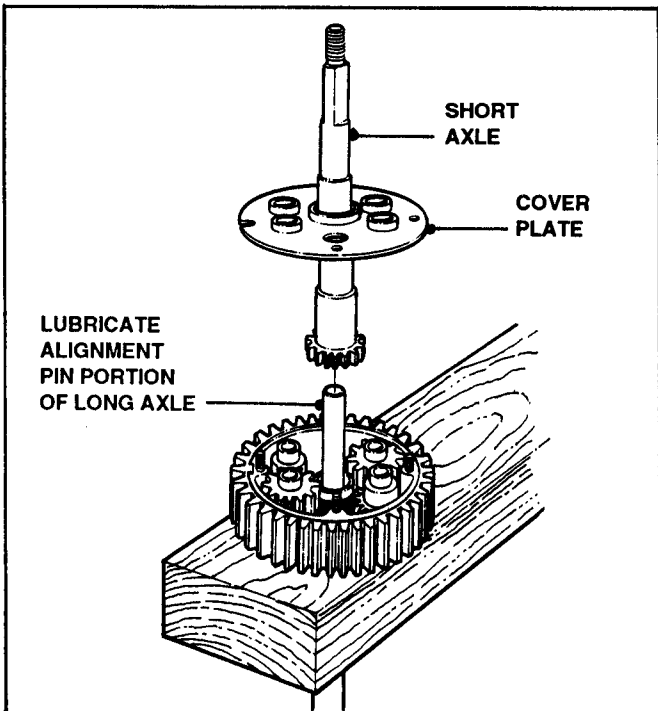

FIGURE 5.12

- Twist Axle to mesh with Gears.
- Install remaining Cover Plate. Refer to Figure 5.12.

- Align Slot on Cover with raised part of Bull Gear.
- Secure Plate retaining capscrews with #10 hex locknuts.
- Tighten Plate retaining capscrew to 32 Ft. Lbs. torque.
- Test Rotate Shafts to insure Gears mesh properly before installing completed Bull Gear - Axle Assembly in Transmission Housing. See Figure 5.13.

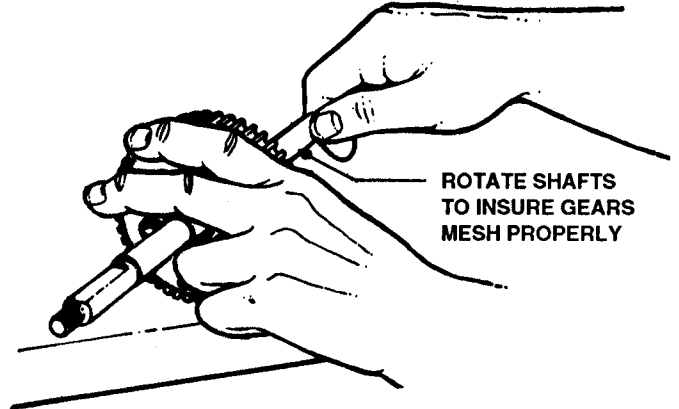

FIGURE 5.13

B. HOUSINGS:

- Check bearings and oil seals in right and left Differential Housings and replace as needed prior to reassembling transmission. Removal and replacement procedure is as follows:
 - Drive tapered O.D. axle bearings out of housings from the INSIDE. See Figure 5.14.

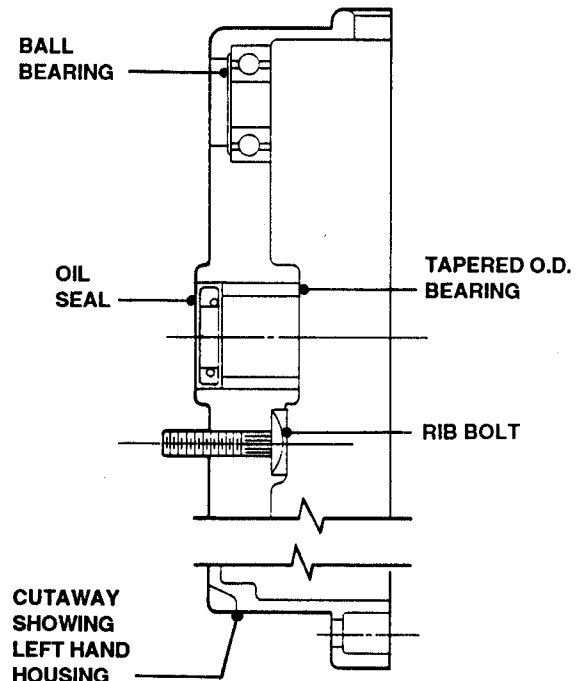

FIGURE 5.14

Section V - OVERHAUL & REPAIR

- (b) Replace new tapered O.D. bearings into housing from the OUTSIDE with a sleeve of appropriate diameter and an arbor press, if available.

NOTE!
Ball Bearing for Input Gear on Right Housing Side is a light press fit in the Left Housing.

- (c) Press the Input Shaft ball bearing into the Right Housing from the INSIDE using a sleeve of appropriate diameter.
(d) Press the Input Shaft ball bearing into the Left Housing from the INSIDE.
(e) Drive old rib bolts in Left Housing out toward the INSIDE, preferably using a plastic mallet. Install new rib bolts from kit. Refer to Figure 5.14.

NOTE!
Faulty Oil Seals may be replaced **without** disassembling Transmission. However, Transmission **MUST** be removed from mower to replace seals.

2. Removing Oil Seals:

- (a) Pry faulty Oil Seals out of recess in Right and Left Housings with a punch or other suitable tool without damaging surfaces. See Figure 5.15.

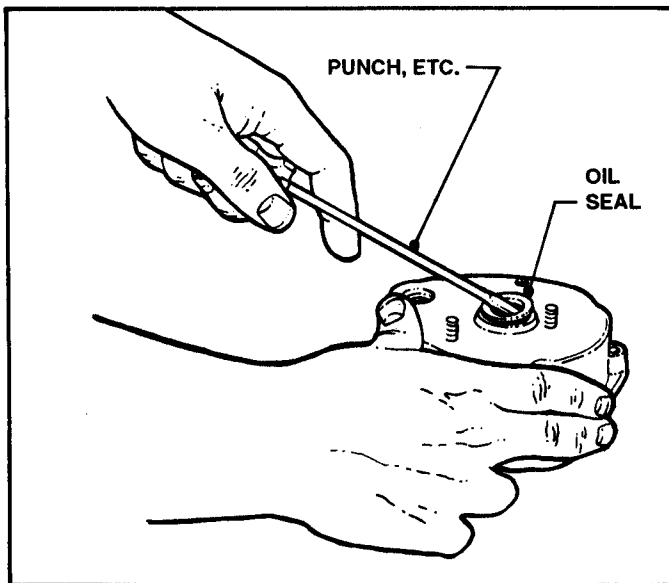

FIGURE 5.15

- (b) Sand off burrs, sharp edges or paint buildup on axles with an emery cloth.

NOTE!
Alternately place each Housing Half over Short Axle to properly install Oil Seals.

- (c) Grease Axle Shaft.
(d) Install Seal Sleeves over Shafts.

3. Replacing Oil Seals:

- (a) Install replacement Seals carefully into position.
(b) Press or drive Seal into Housing, using a Seal Driver of appropriate dimensions. See Figure 5.16.
(c) Lightly grease Seals with SNAPPER "00" grease.

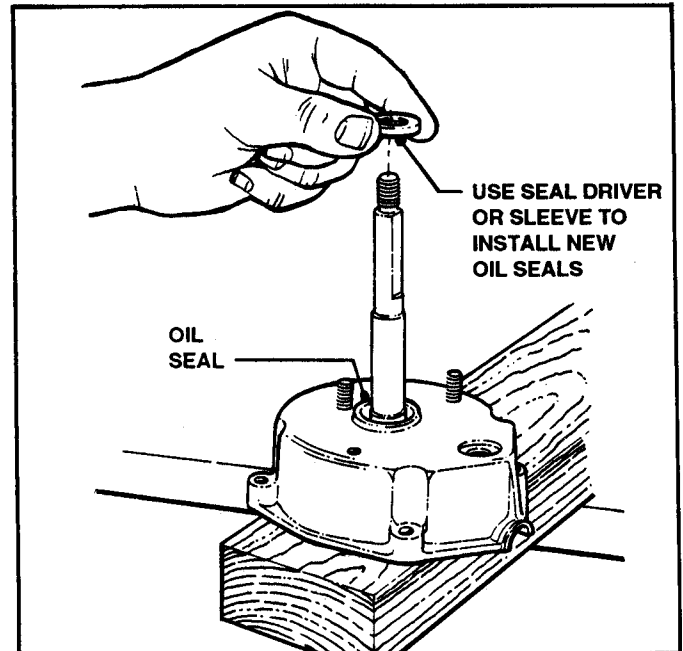

FIGURE 5.16

5.5 TRANSMISSION REASSEMBLY

A. Procedure is as follows:

1. Insert two roll pins in the Right Housing.
2. Install new Housing gasket.
3. Grease Axle Bushing.
4. Install one of two Thrust Washers on Bushing. See Figure 5.17.

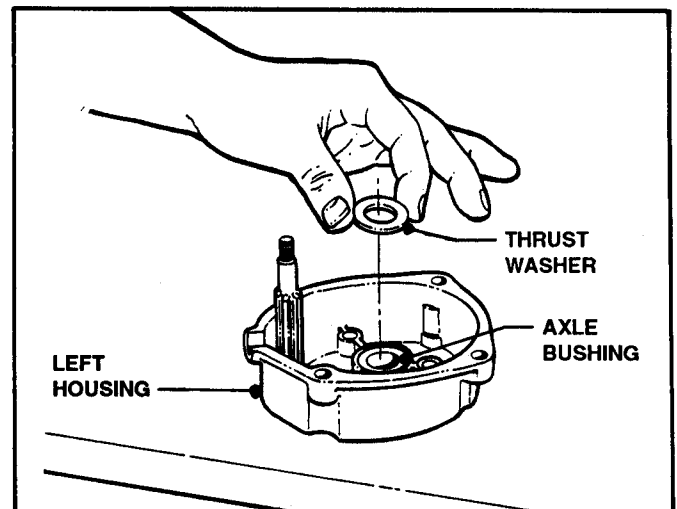

FIGURE 5.17

Section V - OVERHAUL & REPAIR

5. Use an emery cloth to sand burrs, sharp edges or paint buildup from axles.
6. Install Seal Sleeve of appropriate diameter over long axle.
7. Install Seal, using a Seal Driver of appropriate dimensions.
8. Lightly coat Seal with SNAPPER "00" grease.
9. Grease Axles and guide Long Axle through Seal in Right Housing with Seal Driver. See Figure 5.18.

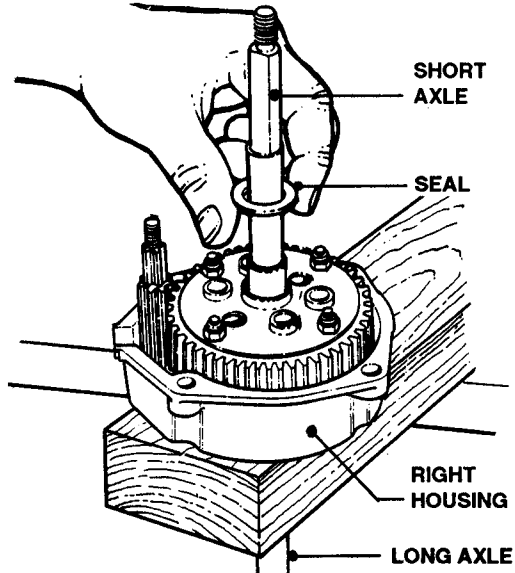

FIGURE 5.18

10. Seat Bull Gear in Right Housing.
11. Insert remaining Thrust Washer over Short Axle.
12. Place Seal Sleeve over Short Axle.
13. Install Seal, using a Seal Driver of appropriate dimensions.
14. Lightly coat Seal with SNAPPER "00" grease.
15. Guide Left Housing into position on Left Housing. See Figure 5.19.

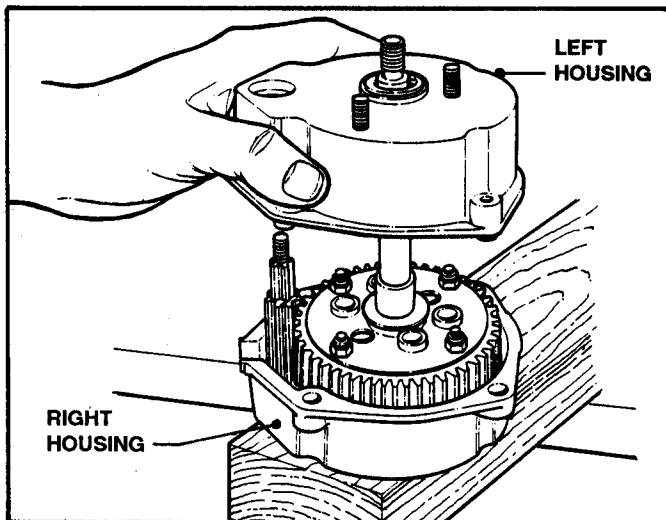

FIGURE 5.19

16. Install the four 1 3/8" Housing capscrews.
17. Secure locknuts.
18. Place Spring Washer on Input Shaft. See Figure 5.20.

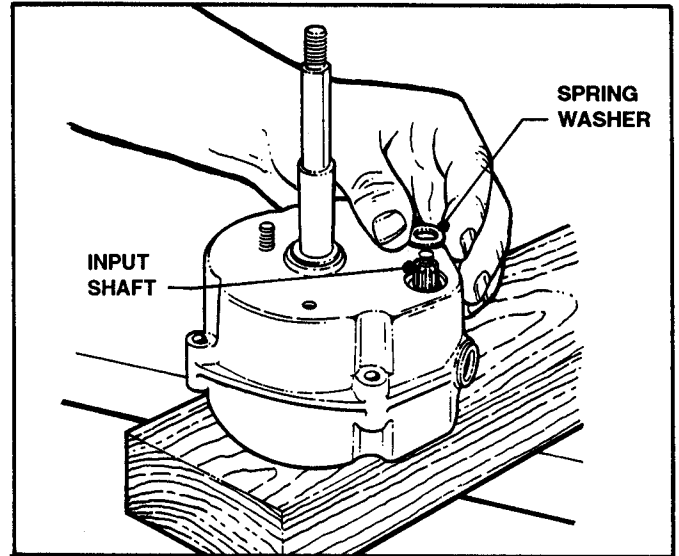

FIGURE 5.20

19. Place an internal-external tooth lockwasher over both of the rib neck bolts protruding from the Right Housing. See Figure 5.21.

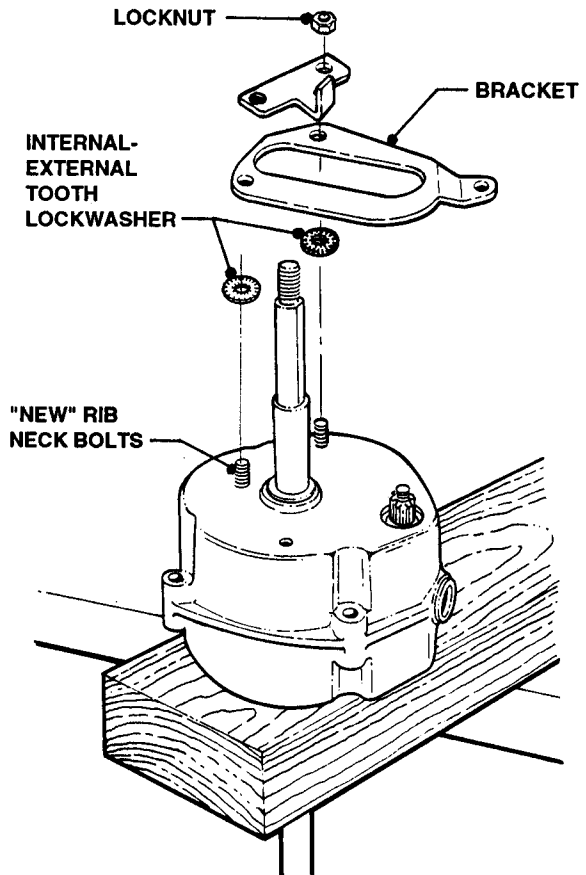

FIGURE 5.21

Section V - OVERHAUL & REPAIR

20. Position Differential Bracket onto rib neck bolts. (Refer to Figure 5.21).
21. Secure Differential Bracket with locknuts. Tighten not more than 17 Ft. Lbs. with torque wrench.
22. Install Poly "V" Pulley, large spring washer and retaining nut. See Figure 5.22.

NOTE

Always use a Seal Sleeve when installing new Oil Seals. If none are available, smooth axle edges by applying tape, and carefully guide Seal over taped areas.

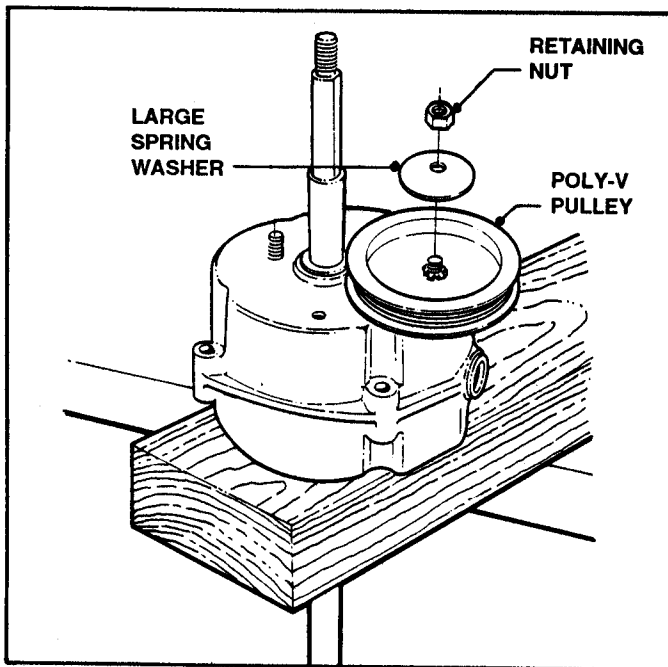

FIGURE 5.22

23. Block Fins on underside of Pulley with wrench and tighten retaining nut.
24. Apply 4 oz. of SNAPPER "00" grease to Housing plug opening and push Housing plug into Housing.
25. Reinstall unit into mower by reversing procedure described at beginning of instructions.

Section VI - ELECTRICAL

6.1 BATTERY REMOVAL AND INSTALLATION

ITEM	PART NO.	DESCRIPTION
1	3-3933	BRACKET, Mounting
2	9-1235	SCREW, 1/4-20 x 3-1/2" Hex Head Cap (2)
3	9-1099	NUT, 1/4-20 Hex Center Lock (2)
4	9-0999	SCREW, 1/4-20 x 5/8" Self-Tapping (4)
5	1-1167	KEY, Switch (2)
6	1-5207	ASSEMBLY, Seal & Face Nut
7	2-3894	COVER, Switch
8	1-5206	NUT, 3/4-20 Lock
9	1-5205	SWITCH, Ignition
10	2-6689	HARNESS, Wiring
-	6-7012	KIT, Battery (Includes items 11 thru 14)
11	1-5488	HARNESS, Battery
12	4-3977	SCREW, M10-8 x 10mm Hex Head Cap (2)
13	9-0932	NUT, M10-8 Hex (2)
14	1-9763	BATTERY, 12 Volt

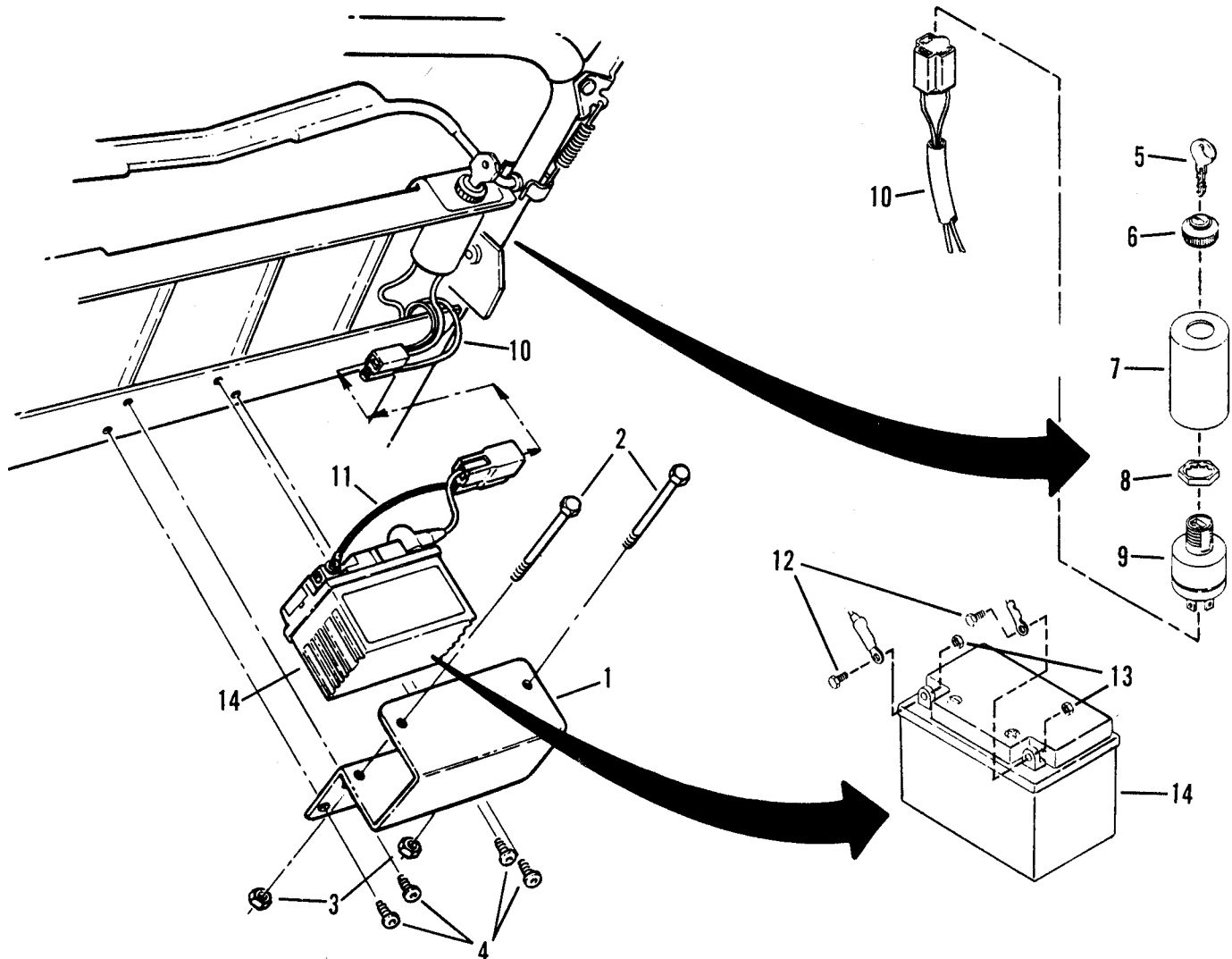

Service Manual for

SNAPPER[®]

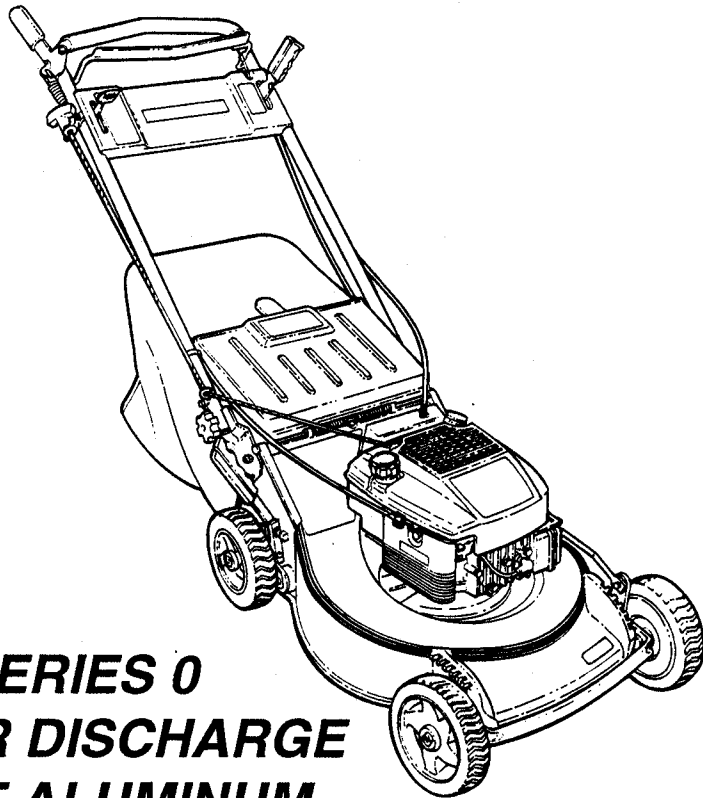

**21" SERIES 0
REAR DISCHARGE
CAST ALUMINUM
MODELS XP21500
(SELF-PROPELLED)
& X21500 (PUSH)
WALK BEHIND
MOWERS**

SNAPPER[®] McDonough, GA., 30253 U.S.A.