

DEALER SET-UP INSTRUCTIONS for EUROPEAN SNAPPER 21" CAST ALUMINUM REAR DISCHARGE WALK BEHIND MOWERS

This SNAPPER Walk Behind Mower uses a handle engine control bail system to kill the engine for the SAFETY of the operator. These mowers are designed for quick set-up. The checklist on Page 3 should be filled out by the dealer as the items are checked off and/or performed and the Consumer/Operator Product Registration card filled out and sent to the Customer Service department at SNAPPER when completed. CAUTION: Cutting blades are extremely sharp. Wear heavy leather gloves when handling or working with blades. Be careful to avoid cutting yourself on sharp edges of blade.

STEP 1: Remove unit from carton and unfold handle. Do this carefully to prevent cables from hanging up or becoming kinked. It will be necessary to remove cardboard isolators between the handles and knobs. Tighten Handle Knobs securely. See Figure 1.

STEP 2: Hold blade control bail down and at the same time, pull engine rope handle and wrap pull cord into rope guides that are located on handles. See Figure 1.

STEP 3: Tip mower back against the upper handle to gain access to cutting blade. Remove foam shipping block from cutting blade. This must be removed before starting the engine.

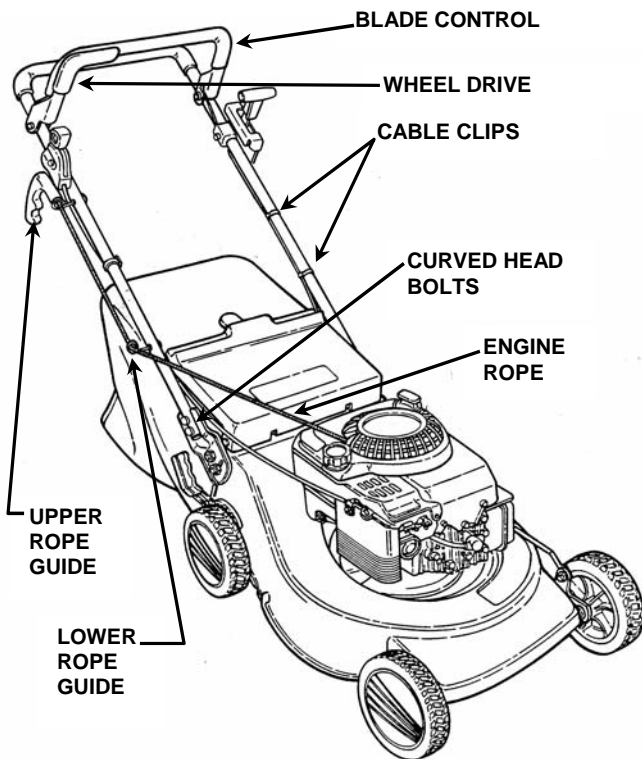

FIGURE 1

IMPORTANT: This mower is shipped with the recycling plug installed. The plug must be removed if the mower is operated with grass catcher. DO NOT start or operate this mower without the plug or the entire grass catcher in place.

STEP 4: With grass catcher and catcher frame assembly upside down (plastic bottom turned up), insert bag frame assembly into catcher as shown in Figure 2. Fasten "C" shaped plastic edge strip located on front of bag around frame assembly on all four sides. Make sure edge strip is fastened securely.

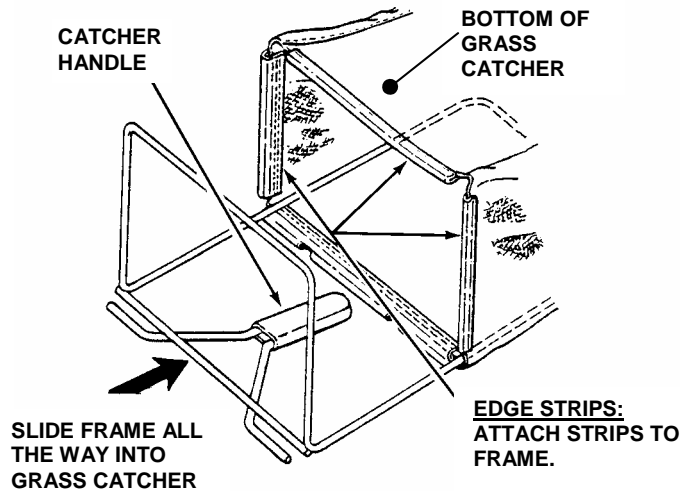

FIGURE 2

STEP 5: Install grass catcher to mower as follows: Lift discharge door, then grasp handle and hold grass catcher/frame up while placing rod ends over tabs at rear of mower deck. Release discharge door. See Figure 3.

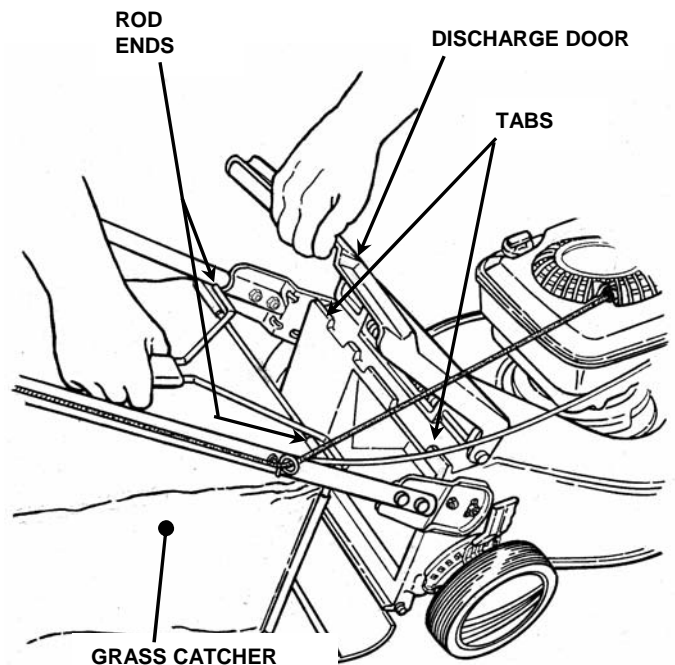

FIGURE 3

WARNING

DO NOT over fill battery with electrolyte. Shield the positive terminal with terminal cover located on battery harness. This prevents metal from touching the positive terminal which could cause sparks. The electrolyte (acid) produces a highly explosive gas. Keep all sparks, flame and fire away from area when charging battery or when handling electrolyte or battery. Electrolyte (acid) is a highly corrosive liquid. Wear eye protection. Wash affected areas immediately after having eye or skin contact with electrolyte (acid). Battery acid is corrosive. Rinse empty acid containers with water and mutilate before discarding. If acid is spilled on battery, bench, or clothing, etc., Flush with clear water and neutralize with baking soda. **DO NOT** attempt to charge battery while installed on the walk behind. **DO NOT** use "BOOST" chargers on the battery.

IMPORTANT: Only use battery charger provided with the kit to charge battery.

1. Remove battery from carton.
2. Place battery in a well ventilated area on a level non-concrete surface.
3. Remove sealing tape from top of battery, exposing cells.
4. Prepare electrolyte and fill cells, following instructions provided with the electrolyte.
5. Install strip of battery plugs making sure that each plug is fully seated and each cell is sealed.
6. Slow charge battery for a minimum of 18 hours using charger provided with kit, being careful to observe correct charger and battery polarity.
7. Loosen bolts that secure battery bracket to deck. Slide battery into battery bracket. Tighten bracket bolts securely. See Figure 4.
8. Connect battery harness to main harness. See Figure 4.

STEP 6: ACTIVATING AND CHARGING BATTERY

Electric start models are shipped with a Battery Kit. The kit includes a dry charged battery, hardware, harness, battery charger, electrolyte (acid) and instructions. The battery requires activation and charging prior to being installed on the mower. The electrolyte is a very dangerous, corrosive and poisonous liquid. Follow very carefully, all instructions and warnings provided with the kit.

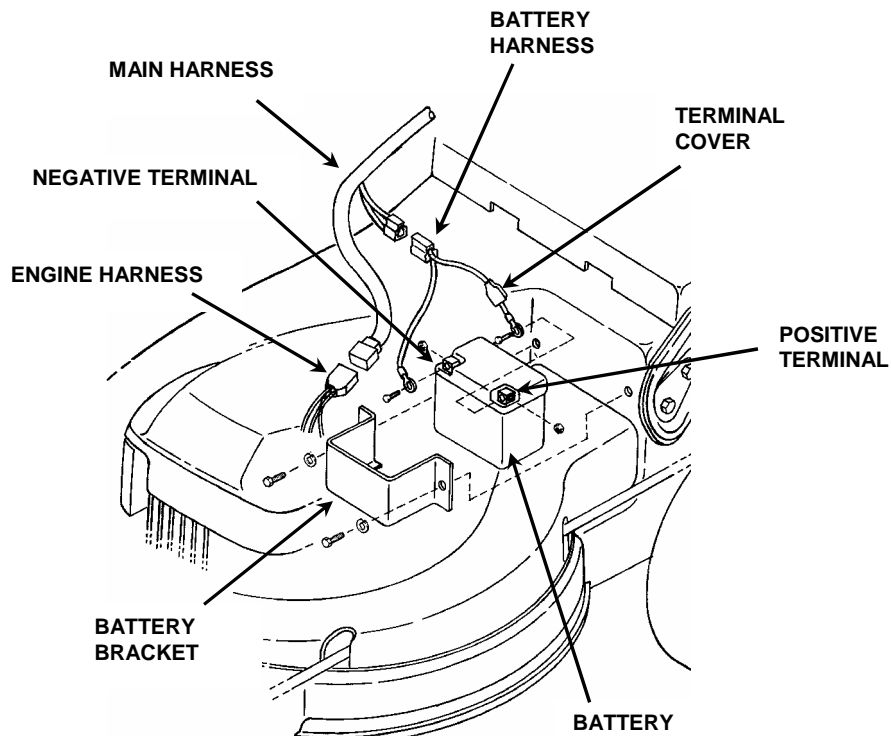

FIGURE 4

DEALER PRE-SALE CHECKLIST for SNAPPER 21" CAST ALUMINUM REAR DISCHARGE WALK BEHIND MOWERS

The following must be accomplished prior to sale. Refer to the previous pages in this instruction for detailed set-up instructions. Review this checklist with purchaser. Check (✓) items actually performed and signed on checklist.

SET-UP CHECKLIST

- _____ FOAM SHIPPING BLOCK removed from cutting blade.
- _____ UPPER HANDLE & LOWER HANDLE secured in place and hardware tightened securely.
- _____ SIDE CHUTE, RECYCLING PLUG or GRASS CATCHER installed on mower.
- _____ BLADE retaining bolt(s) checked and tighten securely.
- _____ BATTERY, electrolyte added to proper level, charged and installed. All cables connected (Electric Start Models).

LUBRICATION

- _____ ENGINE OIL added to bring level up to full mark on 4-cycle engines (Refer to Engine Manual).
- _____ OIL mixed with FUEL in specified ratio (2 Cycle Engines Only).

OPERATIONAL TEST

- _____ ENGINE started, engine control settings checked and adjusted as needed.
- _____ WHEEL DRIVE checked for proper operation and adjusted as needed (Self-Propelled Models).
- _____ GROUND SPEED control checked (Self-Propelled Models).

CPSC (Consumer Product Safety Commission) COMPLIANCE TEST

- _____ BLADE CONTROL stops engine when released.

DEALER'S RECORDS & FINAL CHECK

- _____ PERSONALLY HANDED Operator's Manual & Mower Safety Booklet to purchaser.
- _____ INSTRUCTED purchaser to read and follow instructions in Operator's Manual.
- _____ DEMONSTRATED proper starting procedure and operation of mower to purchaser.
- _____ INSTRUCTED purchaser how to service air cleaner, maintain oil level (4-cycle), or mix oil (2-cycle).
- _____ ASSISTED purchaser in completing Product Registration Card.

CONSUMER/OPERATOR PRODUCT REGISTRATION CARD

Purchase Date _____ Model _____ Serial No. _____

Retailers Name _____ Signature _____

Address _____ City _____ State _____ Zip _____

MOWER WILL BE USED COMMERCIALY? _____ YES _____ NO

Purchaser's Name _____ Signature _____

Address _____ City _____ State _____ Zip _____

IMPORTANT: This form is to be retained by the Dealer for future reference regarding Warranty, proof of purchase, traceability for product recall or service, etc. Complete the Product Registration Card and Mail to Customer Service Department at SNAPPER, P.O. BOX 1379, McDonough, Georgia, 30253.