

# Safety Instructions & Operator's Manual for

# SNAPPER®

## PRO HYDRO WALK BEHIND MOWERS MID-SIZE SERIES 1



Model SPLH141KW shown

POWER UNIT MODELS	MOWER UNIT MODELS
SPLH141KW	SP360
SPLH171KW	SP480
SPLH151KH	SPA360
SPLH141KWE	SPA480
SPLH221KHE	SPA520
	SPA610

### MODEL NUMBER EXPLANATION

**S P L H 14 1 KW**

MODEL DESIGNATION  
MODEL TYPE  
MODEL OPTION  
DRIVE SYSTEM TYPE

ENGINE TYPE  
SERIES DESIGNATION  
ENGINE HP

S - Snapper Commercial Model	ENGINE HORSE POWER	CUTTING DECK WIDTH	1 - Series Designation	KW - Kawasaki Engine
P - Pro Mid Size Model	14 - 14.0 Engine HP	36 - 36" Cutting Deck		KH - Kohler Engine
L - Loop Type Handle Model	15 - 15.0 Engine HP	48 - 48" Cutting Deck		E - Electric Starting
H - Hydro Drive System	16 - 16.0 Engine HP	52 - 52" Cutting Deck		
A - Adjustable Cutting Deck	17 - 17.0 Engine HP	61 - 61" Cutting Deck		
	18 - 18.0 Engine HP			
	22 - 22.0 Engine HP			

*Thank you for buying a SNAPPER Product! Before operating your PRO WALK BEHIND, read this manual carefully and pay particular attention to the "IMPORTANT SAFETY INSTRUCTIONS" on Pages 2 & 3. Remember that all power equipment can be dangerous if used improperly. Also keep in mind that SAFETY requires careful use in accordance with the operating instructions and common sense!*

**SNAPPER**®McDonough, GA., 30253 U.S.A.



# IMPORTANT SAFETY INSTRUCTIONS



**WARNING:** This powerful cutting machine is capable of amputating hands and feet and can throw objects that can cause injury and damage! Failure to comply with the following SAFETY instructions could result in serious injury or death to the operator or other persons. The owner of the machine must understand these instructions and must allow only persons who understand these instructions to operate machine. Each person operating the machine must be of sound mind and body and must not be under the influence of any substance, which might impair vision, dexterity or judgment. If you have any questions pertaining to your machine which your dealer cannot answer to your satisfaction, call or write the Customer Service Department at SNAPPER, McDonough, Georgia 30253. Phone: (1-800-935-2967).

## PROTECTION FOR CHILDREN

Tragic accidents can occur if the operator is not alert to the presence of children. Children are often attracted to the machine and the mowing activity. Never assume that children will remain where you last saw them.

1. KEEP children out of the mowing area and under the watchful care of a responsible adult.
2. DO NOT allow children in yard when machine is operated (even with the blades OFF).
3. DO NOT allow children or others to ride on machine or on attachments (even with the blades OFF). They may fall and be seriously injured.
4. DO NOT allow pre-teenage children to operate machine.
5. ALLOW only adults or responsible teenagers with mature judgment under close adult supervision to operate machine.
6. DO NOT operate blades in reverse. STOP BLADES. LOOK and SEE behind and down for children, pets and hazards before and while backing.
7. USE EXTRA CARE when approaching blind corners, shrubs, trees, or other objects that may obscure vision.

## SLOPE OPERATION

1. Slopes are a major factor related to slip and fall accidents, which can result in severe injury. All slopes require extra caution. If you feel uneasy on a slope, DO NOT mow it.
2. Mow across slopes, never up and down. Exercise extreme CAUTION when changing directions on slopes. Practice operation of machine on slopes with blades off.
3. Use extra care with grass catchers or other attachments: these affect the handling and the stability of the machine.
4. DO NOT use tow behind attachments on slopes.
5. AVOID uphill starts.
6. DO NOT operate machine under any condition where traction, steering or stability is doubtful.

## PREPARATION

1. Read, understand and follow instructions and warnings in this manual and on the machine, engine, and attachments. Know the controls and the proper use of the machine before starting.
2. Only mature, responsible persons shall operate the machine and only after proper instruction.
3. Data indicates that operators age 60 and above, are involved in a large percentage of mower-related injuries. These operators should evaluate their ability to operate the mower safely enough to protect themselves and others from serious injury.
4. Handle fuel with extra care. Fuels are flammable and vapors are explosive. Use only an approved fuel container. DO NOT remove fuel cap or add fuel with engine running. Add fuel outdoors only with engine stopped and cool. Clean spilled fuel from machine. DO NOT smoke.
5. Practice operation of machine with BLADES OFF to learn controls and develop skills.
6. Check the area to be mowed and remove all objects such as toys, wire, rocks, limbs and other objects that could cause injury if thrown by blade or interfere with mowing.
7. Keep people and pets out of mowing area. Immediately, STOP blades, STOP engine, and Stop machine if anyone enters the area.
8. Check shields, deflectors, switches, blade controls and other safety devices frequently for proper operation and location.
9. Make sure all safety decals are clearly legible. Replace if damaged.
10. Protect yourself when mowing and wear safety glasses, long pants and substantial footwear.
11. Know how to STOP blades and engine quickly in preparation for emergencies.
12. Use extra care when loading or unloading the machine into a trailer or truck.
13. Check grass catcher components frequently for signs of wear or deterioration and replace as needed to prevent injury from thrown objects going through weak or worn spots.



# IMPORTANT SAFETY INSTRUCTIONS



## OPERATION

1. **DO NOT** put hands or feet near or under rotating parts. Keep clear of the discharge area while the engine is running.
2. Stop Blades when crossing gravel drive, walks, and under any conditions where thrown objects might be a hazard.
3. Mow only in daylight or good artificial light.
4. **DO NOT** operate the machine while under the influence of alcohol or drugs.
5. After striking a foreign object or if the mower vibrates abnormally, **STOP** the blades and engine. Remove the key. Disconnect and secure the spark plug wire. Inspect the mower for any damage and repair the damage.
6. **DO NOT** operate machine near drop offs, ditches, or embankments. Operator could lose footing or balance.
7. **STAY ALERT** for holes and other hidden hazards. Tall grass can hide obstacles. Keep away from ditches, washouts, culverts, fences and protruding objects.
8. **DO NOT** operate machine on wet grass. Always be sure of your footing: keep a firm grip on the handle and walk: never run. Slipping could cause injury.
9. **DO NOT** leave the machine with the engine running. **STOP BLADES, STOP ENGINE** and **REMOVE KEY** before leaving the operator position for any reason.
10. Before cleaning, repairing, or inspecting make certain blades, engine and all moving parts have **STOPPED**. Remove key and secure spark plug wire away from spark plug key to prevent accidental starting.
11. **STOP BLADES** and **ENGINE** and make sure blades have stopped before removing grass catcher or unclogging mower to prevent loss of fingers or hand.
12. Blades must be **OFF** except when cutting grass. Set blades in highest position when mowing over rough ground.
13. Keep hands and feet away from rotating blades underneath deck.
14. **DO NOT** operate machine without entire grass catcher or guards in place. **DO NOT** point discharge at people, passing cars, windows or doors.
15. Slow down before turning.
16. Watch out for traffic when near or crossing roadways.
17. Move motion control levers **SLOWLY** to maintain control during speed and directional changes.
18. **DO NOT** operate engine in enclosed areas. Engine exhaust gases contain carbon monoxide, a deadly poison.

## MAINTENANCE

1. **DO NOT** store machine or fuel container inside where fumes may reach an open flame, spark or pilot light such as in a water heater, furnace, clothes dryer or other gas appliance. Allow engine to cool before storing machine in an enclosure. Store fuel container out of the reach of children in a well ventilated, unoccupied building.
2. Keep engine free of grass, leaves or excess grease to reduce fire hazard and engine overheating.
3. When draining fuel tank, drain fuel into an approved container outdoors and away from open flame.
4. Check brakes frequently (if equipped); adjust, repair or replace as needed.
5. Keep all bolts, nuts and screws properly tight. Check that all cotter pins are in proper position.
6. Always provide adequate ventilation when running engine. Exhaust gases contain carbon monoxide, an odorless and deadly poison.
7. Disconnect negative (black) cable from battery (if equipped) before performing maintenance or service. Cranking engine could cause injury.
8. **DO NOT** work under machine without safety blocks.
9. Service engine and make adjustments only when engine is stopped. Remove key. Remove spark plug wire(s) from spark plug(s) and secure wire(s) away from spark plug(s).
10. **DO NOT** change engine governor speed settings or overspeed engine.
11. Lubricate machine at intervals specified in manual to prevent controls from binding.
12. Mower blades are sharp and can cut. Wrap the blades or wear heavy leather gloves and use **CAUTION** when handling them.
13. **DO NOT** test for spark by grounding spark plug next to spark plug hole; spark plug could ignite gas exiting engine.
14. Have machine serviced by an authorized **SNAPPER** dealer at least once a year and have the dealer install any new safety devices.
15. Use only genuine **SNAPPER** replacement parts to assure that original standards are maintained.

# TABLE OF CONTENTS

IMPORTANT SAFETY INSTRUCTIONS .....	2-3
TABLE OF CONTENTS .....	4
SECTION 1 - FAMILIARIZATION .....	5
SECTION 2 - CONTROLS .....	6
Engine Controls .....	6
Blade and Traction Controls .....	6
TO ROLL MACHINE - Pressure Relief Valve Adjustment .....	6
SECTION 3 - OPERATING INSTRUCTIONS .....	7-15
Pre-Start Checklist .....	7
Hydraulic Oil Reservoir .....	7
Engine Oil .....	7
Before Operating .....	7
Stopping .....	8
Starting and Operating .....	8
Traction Speed Control .....	9
Reverse Speed .....	9
Mower Operation .....	9-10
Mowing and Turning on Hillsides .....	10
Handle Height Adjustment .....	10-11
Cutting Height Adjustment (Fixed Decks) .....	12
Adjusting Caster Wheels (Fixed Decks) .....	12
Adjusting Blade on Cutter Spindle (Fixed Decks) .....	12
Adjusting Fixed Deck Attachment .....	13
Cutting Height Adjustments for Adjustable Deck Attachments .....	13
SECTION 4 - SERVICE .....	14-19
Engine Troubleshooting .....	14
Service & Lubrication Information .....	15-16
Maintenance Replacement Parts .....	16
Electric Clutch Adjustment .....	17
Hydraulic Systems Adjustments & Service .....	17
Pump/Motor Replacement .....	17
Hydraulic Pump Belt Removal & Installation .....	17-18
Replacement Parts .....	18
Machine Speed Control Ranges .....	18
Traction Control Neutral Adjustment .....	19
SECTION 5 - MOWER ATTACHMENT SERVICE .....	20-22
<u>36" CUTTING DECK</u> Cutting Deck Belt Removal & Installation .....	20
<u>48", 52", &amp; 61" CUTTING DECK</u> Cutting Deck Belt Removal & Installation .....	20
Cutting Deck Spindle Belt Removal & Installation .....	20-21
<u>CUTTING BLADE SERVICE</u> Blade Inspection .....	21
Blade Removal & Sharpening .....	21
Mower Spindles (Field Serviceable Spindles) Bearing Replacement .....	22
SECTION 6 - BATTERY SERVICE & TESTING .....	23-24
WARRANTY .....	25
PRIMARY MAINTENANCE .....	26-29

# SECTION 1 - FAMILIARIZATION

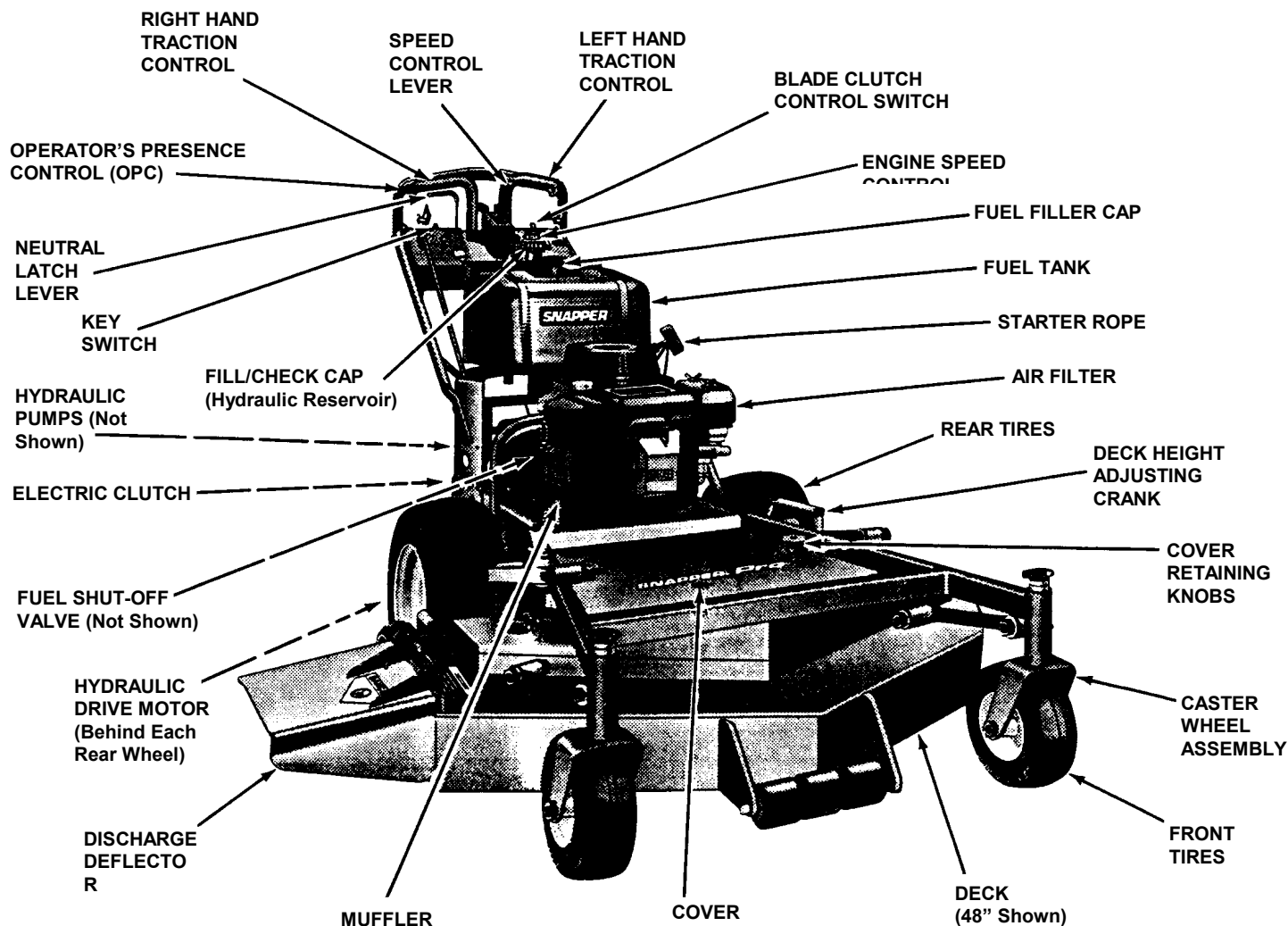

FIGURE 1.1

## 1.1 INTRODUCTION

This manual has been prepared for the operator's of the SNAPPER PRO HYDRO WALK BEHIND MOWER. Its purpose, aside from recommending standard operating procedures and routine service requirements, is to promote SAFETY through the use of accepted operating practices. Read, Understand and Follow the IMPORTANT SAFETY INSTRUCTIONS on Pages 2 & 3 of this manual and All SAFETY messages on the PRO HYDRO WALK BEHIND MOWER and its attachments before operating. SNAPPER recommends returning the machine to an authorized SNAPPER dealer annually for inspection and addition of any new devices which might upgrade the safety of the mower.

## 1.2 NOMENCLATURE

It is recommended that all operator's of this equipment become thoroughly familiar with the controls, components, and operation of this machine before operating. Specific details involving the engine are found in the separate engine owner's manual. Study these manuals before operating and keep both handy for future reference. For the nearest SNAPPER dealer in your area, check the yellow pages under the heading LAWN MOWERS. For engine parts and service, look for the engine manufacturer's dealers under the heading, ENGINES – gasoline.

# SECTION 2 - CONTROLS

Before operating, become familiar with all the controls (See Figure 2.1A) and how to use them. Know beforehand how to STOP the Right Hand and Left Hand Traction Wheel Drives, the Mower Blades, and the Engine in preparation for a possible emergency.

## 2.1 ENGINE CONTROLS -

- A. Engine Speed Control
- B. Keyswitch
- C. Operator's Presence Control (OPC)
- D. Engine Recoil Starter Handle (Not shown)

## 2.2 BLADE AND TRACTION CONTROLS

- 1. Blade Clutch Control Switch
- 2. R.H. Steering Control
- 3. L.H. Steering Control
- 4. Neutral Latch Lever
- 5. Speed Control/Park Lock Lever

**WARNING**  
Neutral Latch is not intended to be used as a park brake. Never park machine on slopes.

**WARNING**  
When the Operator's Presence Control (OPC) is released, the machine will continue to operate a few feet. DO NOT use this Operator's Presence Control (OPC) to routinely stop the machine.

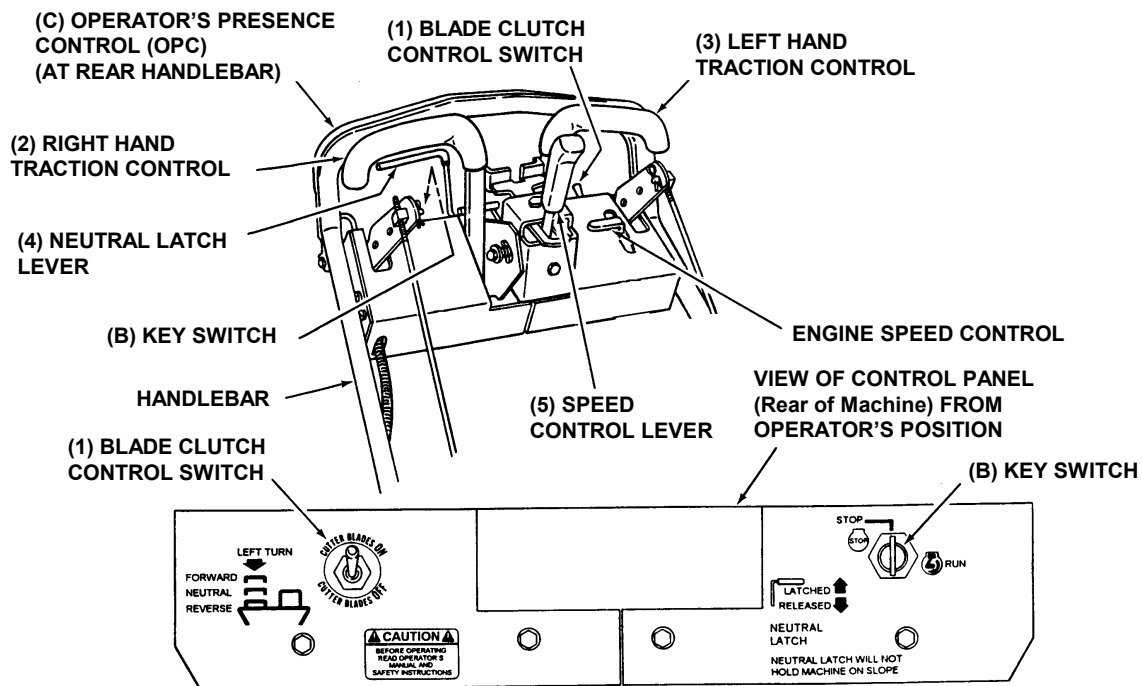

FIGURE 2.1A

**IMPORTANT:** To roll the machine without the engine running, turn both pressure relief valves counter-clockwise 1/2 turn. Turn valves clockwise to tighten for machine operation.

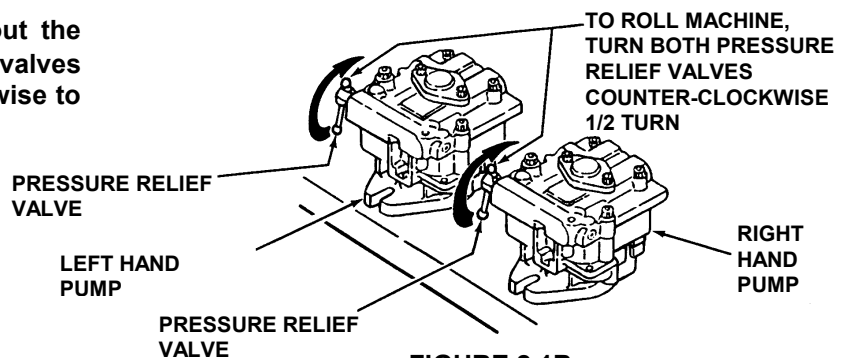

FIGURE 2.1B

# SECTION 3 - OPERATING INSTRUCTIONS

## 3.1 PRE-START CHECKLIST

Make the following checks and perform the services as required before each start-up.

**IMPORTANT:** Before starting your SNAPPER Pro Hydro machine, the hydraulic reservoir and engine **MUST** be filled to the proper level with oil.

**3.1.1. HYDRAULIC OIL RESERVOIR:** Use SAE 10W-30 oil. Fill reservoir with oil until the level comes to within 1-1/2 inches from the top of the filler neck. Check on level surface with engine off. See Figure 3.1.

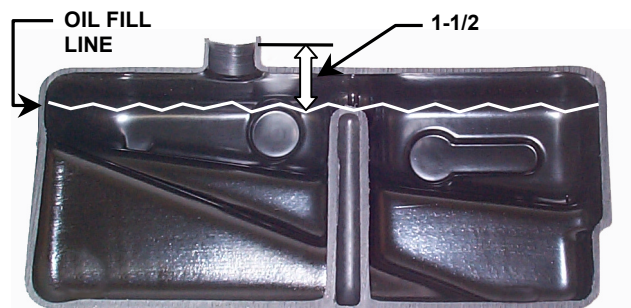

HYDRAULIC OIL RESERVOIR

**IMPORTANT: FLUID LEVEL MUST BE ABOVE TOP OF BAFFLE. RESERVOIR CAPACITY IS ONE (1) GALLON. DO NOT OVERFILL.**

FIGURE 3.1

**3.1.2. ENGINE OIL:** Add oil as needed to bring up to, but not over, the FULL mark. Refer to the Engine Owner's Manual for oil specifications.

1. If required, make cutting height adjustments. Refer to Section "CUTTING HEIGHT ADJUSTMENT".
2. Check tires and add air as needed to bring pressure to 25 PSI in front tires and 12-15 PSI in rear tires.
3. Check Guards, Deflectors and Belt Covers to make sure all are in place and secure.
4. Check condition of Cutter Deck Belt(s). If damaged, replace with original part. Refer to Section "CUTTER DECK BELT REMOVAL".
5. Clean Interior and Exterior surfaces of Cutting Deck and clean Engine of any accumulation of dirt, grass, oil, etc. Keep Engine Air Intake Screens and Cooling Fins clear at ALL times.
6. Check Engine Oil Reservoir and add oil as needed to bring level up to but not over the FULL mark. (Refer to Engine Owner's Manual for oil specifications).

	<b>WARNING</b>	
<p>Use approved fuel container. <b>DO NOT</b> smoke near open fuel container. <b>DO NOT</b> fill fuel tank indoors or when engine is running. Allow engine to cool for at least ten minutes before refilling. Wipe off any spilled fuel before starting engine. <b>DO NOT</b> run engine indoors.</p>		

7. Add fuel to tank after pushing the machine outside where FUMES can be dissipated. Make sure Fuel Tank Cap is tightened after refueling. (Refer to Engine Owner's Manual for Fuel specifications).

### 3.1.3. BEFORE OPERATING

Be thoroughly familiar with ALL controls and know how to use them before operating the mower. Know beforehand how to STOP the Traction Drive Wheel Motors, Mower Blades and Engine in preparation for a possible emergency.

# SECTION 3 - OPERATING INSTRUCTIONS

## 3.2 STOPPING

**IMPORTANT:** Pulling backward on both Traction Controls back past Neutral position will cause the machine to back up.

1. Pull back on both Traction Controls simultaneously towards handle bar. Manually engage the Neutral Latch Lever. See Figure 3.2.

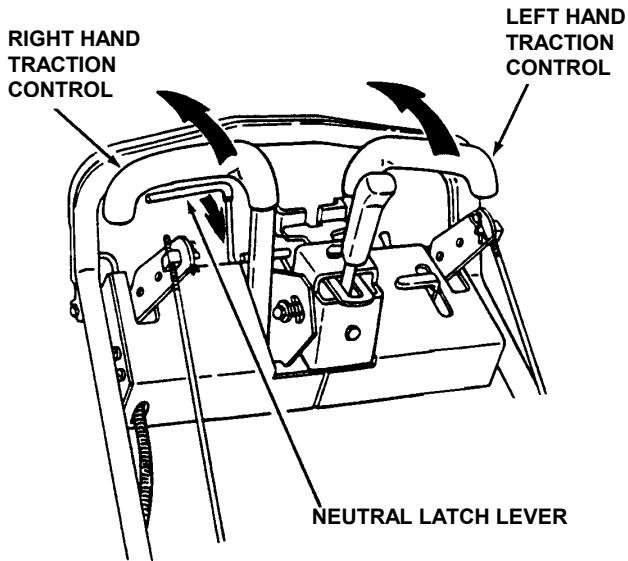

FIGURE 3.2

2. Move Blade Clutch Control Switch to OFF position.
3. Move Engine Speed Control to SLOW (Turtle) Position.
4. Stop Engine by turning Keyswitch to STOP position. Always park machine on level surface.

## 3.3 STARTING AND OPERATING

### 3.3.1. ENGINE - START ENGINE AS FOLLOWS:

1. Turn Fuel Tank Shut-Off Valve ON.
2. Move Blade Clutch Control Switch to OFF position.
3. Be sure Right Hand and Left Hand Traction Controls are latched in NEUTRAL position.
4. Pull Choke Control Knob, if so equipped, (shown attached to Fuel Tank and Handle Support Bracket on Left Hand side of machine) all the way out to CHOKE position. See Figure 3.3.
5. Move Engine Speed Control to "FAST/CHOKE" position, if so equipped. See Figure 3.4.
6. (Manual Start Models) Turn Keyswitch to RUN position.
7. (Manual Start Models) Pull Starter Rope until Engine starts.
8. (Electric Start Models) Hold Operators Presence Control against handlebar. Turn key to the "START" position until engine starts. NOTE: If after 5 seconds of cranking the engine and it does not start, release the key, make sure the blade switch control is in the OFF position and traction controls are latched in the neutral position. Attempt starting again after waiting for approximately 20 seconds.
9. Push Choke Control Knob all the way in and move Engine Speed Control to "FAST" position.

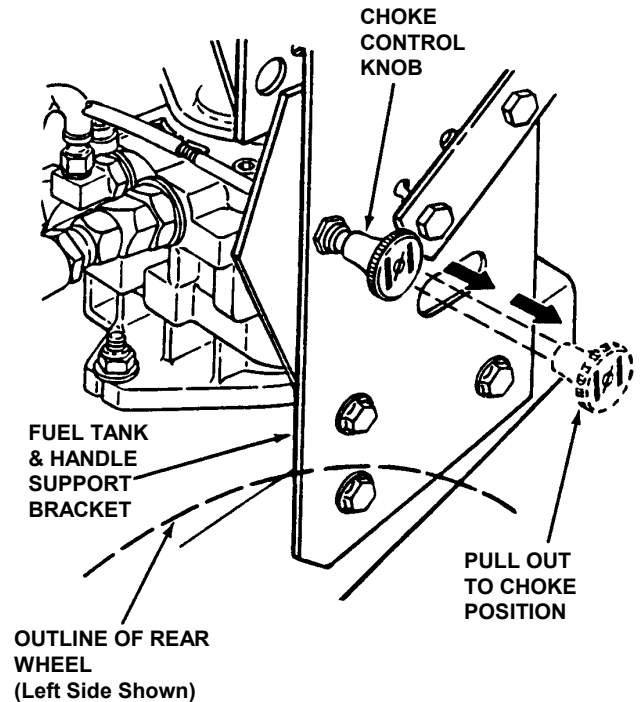

FIGURE 3.3

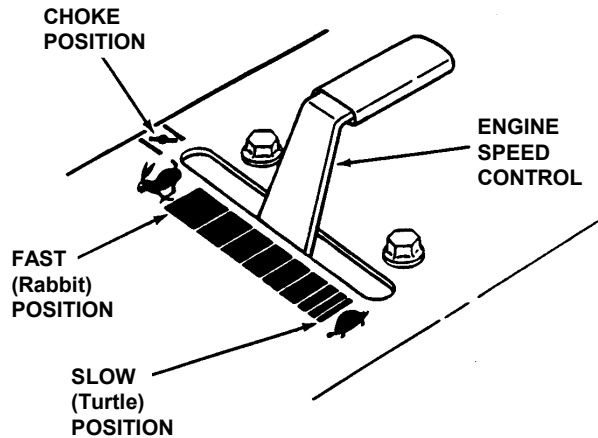
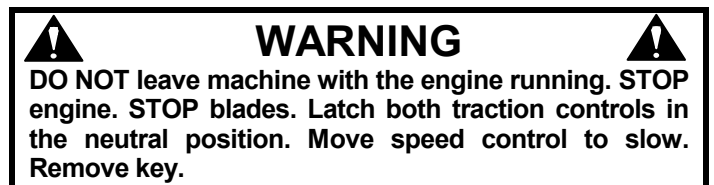

FIGURE 3.4





# SECTION 3 - OPERATING INSTRUCTIONS

**WARNING**

The SNAPPER Pro Hydro Mowers have a Transport Speed, which allows the machine to travel forward at a speed of 6 MPH - it is NOT to be used while walking! Use the Transport Speed ONLY when the machine is equipped with a Riding Sulky! DO NOT make sharp turns at high speed! The machine has “zero-turn” capability; DO NOT use “zero-turn” at high speed. During initial training time with machine, it is advised that the Operator(s) practice with the Speed Control Lever in the slowest travel speed position and Blade Engagement Switch in the OFF position

## 3.4 TRACTION SPEED CONTROL

### 3.4.1. FORWARD SPEED

1. Hold Operator's Presence Control (OPC) against handlebar.
2. Move Speed Control Lever forward slightly, selecting a slow travel speed.
3. While holding both Traction Controls in the neutral position, release Neutral Latch Lever by pulling controls slightly backwards.
4. Simultaneously (and slowly), release both Traction Controls. Machine will begin to move forward.
5. Adjust Speed Control Lever to a comfortable travel speed.
6. Proceed to go forward while allowing the machine to travel in a straight line. If the machine tracks towards the LEFT or RIGHT, it can be brought back to a straight path by moving the Speed Control Lever in the desired direction of travel. See Figure 3.5.
7. Squeeze the appropriate Traction Control to turn the machine either LEFT or RIGHT. If either Traction Control is squeezed to tightly against the handlebar, it will cause the machine to quickly spin around or zero turn to that side - BE CAREFUL!

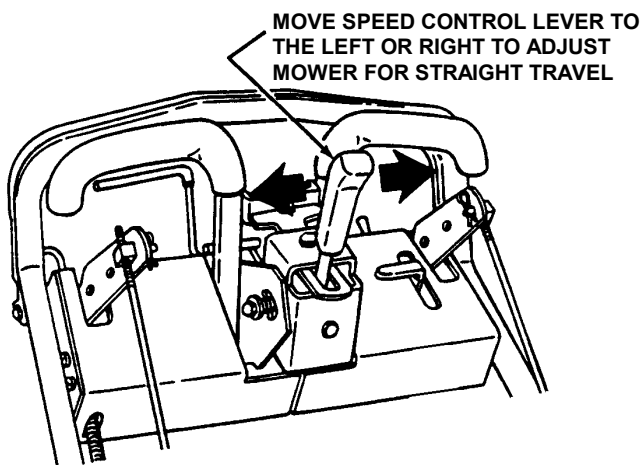

FIGURE 3.5

**WARNING**

The tighter the traction controls are squeezed back against the handlebar, the faster the machine will move in reverse. Use extreme CAUTION when reversing machine!

### 3.4.2. REVERSE SPEED

1. Hold Operator's Presence Control (OPC) against handlebar.
2. Move Blade Control Switch to OFF position.
3. To reverse direction of the machine, stop machine travel by squeezing both Traction Controls and move Neutral Latch Lever to engage and hold the Traction Controls in neutral position.
4. To start machine movement, simultaneously squeeze both Traction Controls SLOWLY back towards the handlebar, allowing machine to start reverse movement. See Figure 3.6.
5. To STOP reverse movement of machine, return both Traction Controls to neutral and engage the Neutral Latch Lever.

**SLOWLY SQUEEZE BOTH TRACTION CONTROLS AGAINST THE HANDLEBAR AT THE SAME TIME TO START REVERSE MOVEMENT**

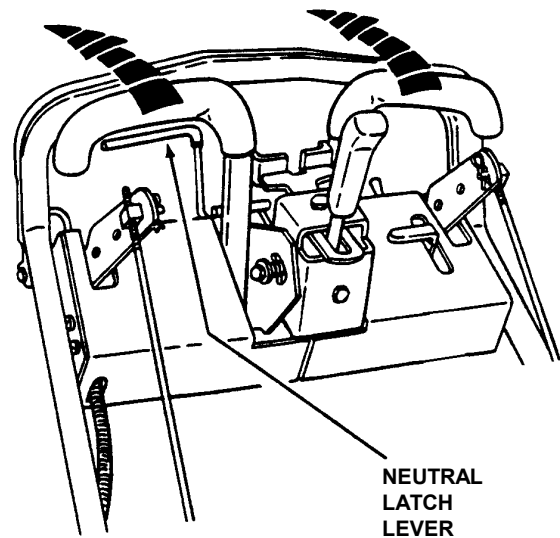

FIGURE 3.6

**WARNING**

Start mowing with a slow ground speed.

## 3.5 MOWER OPERATION

1. Hold Operator's Presence Control (OPC) against handlebar.
2. Move Engine Speed Control to the FAST (Rabbit) position. See Figure 3.4.
3. Move Blade Control Switch to ON position.
4. Move Speed Control Lever forward, selecting a slow travel speed.

**WARNING**

DO NOT operate blades in reverse. STOP blades. LOOK and SEE behind and down for children, pets and hazards before and while backing.

# SECTION 3 - OPERATING INSTRUCTIONS

## 3.5 MOWER OPERATION (Continued from Previous Page)

5. While holding both Traction Controls in the neutral position, release Neutral Latch Lever by pulling controls slightly backwards.
6. Simultaneously (and slowly), release both Traction Controls. Machine will begin to move forward.
7. Adjust Speed Control Lever to a comfortable travel speed.
8. Proceed to go forward while allowing machine to travel in a straight line. If the machine has a tendency to track towards the LEFT or RIGHT, it can be brought back to a straight path by moving Speed Control Lever in the desired direction of travel. See Figure 3.5.
9. Squeeze the appropriate Traction Control to turn the machine either LEFT or RIGHT.
10. If either Traction Control is squeezed tightly against the handlebar, it will cause the corresponding wheel to reverse direction and "zero-turn" the machine. BE CAREFUL!

## 3.7 HANDLE HEIGHT ADJUSTMENT

For operator comfort the height of the handlebars are adjustable to five different positions. The handle height adjustment procedure is sensitive and the following procedures and **WARNINGS** must be followed very carefully.

**WARNING**

Several steps of the handle bar height adjustment procedure require that the engine be started. Exercise extreme CAUTION when making adjustments while the engine is running to avoid HOT engine components, rotating components, run over or entrapment types of injuries.

**IMPORTANT:** To complete this procedure, a steel rod 5/16" diameter and 20" long will be required. DO NOT begin this procedure without it.

**WARNING**

DO NOT attempt any maintenance, adjustments or service with the engine running. Stop engine. Stop blades. Latch Traction Controls in neutral. Move Speed Control lever to SLOW. Remove key. Disconnect spark plug wires from spark plugs and secure wires away from spark plugs. Engine and components are HOT. Avoid serious burns by allowing all parts sufficient time to cool before working on machine.

- STEP 1:** Move machine to smooth level place. Raise rear of machine just high enough for drive wheels to clear the floor and be able to rotate freely. Block machine securely to prevent it from falling.
- STEP 2:** Place traction control levers in the Neutral position and engage Neutral Latch. See Figure 3.8.

**WARNING**

DO NOT use Rider Attachment (Sulky) on slopes! DO NOT park machine on slopes.

## 3.6 MOWING AND TURNING ON HILLSIDES

1. Always mow hillsides starting at bottom of hill. Mow across slopes, never up and down. Exercise CAUTION when changing directions on slopes. **DO NOT MOW STEEP SLOPES.** See Figure 3.7.
2. Hillside mowing is accomplished by squeezing Traction Lever on the UPHILL SIDE of machine. This helps prevent side slipping of mower.
3. When turning mower on hillsides, always turn toward the UPHILL SIDE of mower for better control and balance.

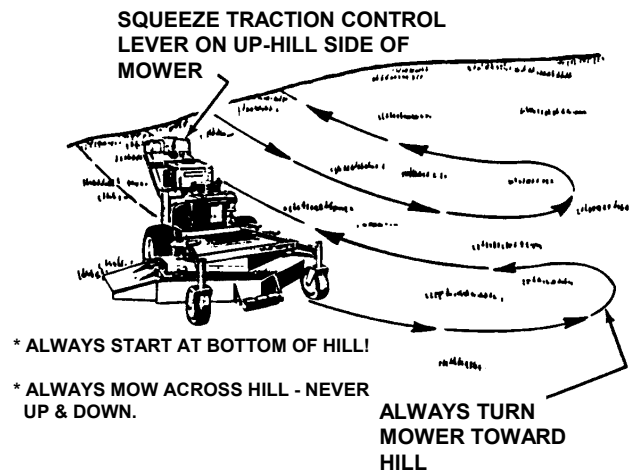

FIGURE 3.7

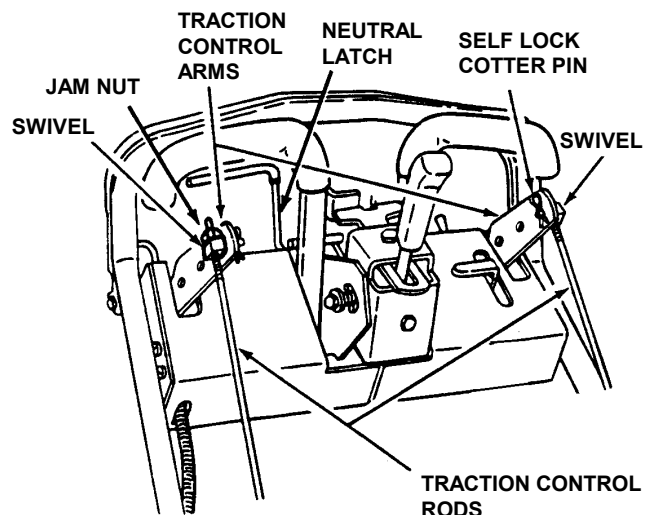

FIGURE 3.8

(Continued on Next Page)

# SECTION 3 - OPERATING INSTRUCTIONS

## 3.7 HANDLE HEIGHT ADJUSTMENT

(Continued from previous page)

**STEP 3:** Insert rod (5/16" diameter x 20" long) through alignment holes in the left and right traction control shift lever arms and the tank support bracket. The rod should pass through both the left and right traction control shift lever arms. See Figure 3.9.

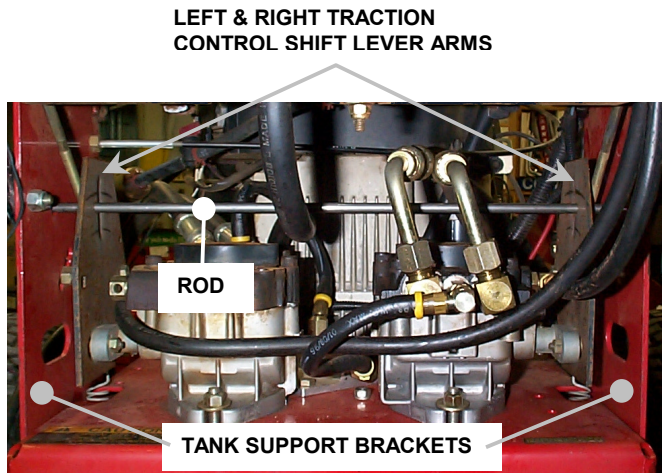

FIGURE 3.9

**STEP 4:** Disconnect the swivel from the right and left traction control arms and loosen swivel jam nuts. Refer to Figure 3.8.

**STEP 5:** Loosen the upper bolt and nut on right and left side of Mower which holds Handlebar to Support Bracket. Remove the lower bolt and nut on each side. Retain this hardware. See Figure 3.10.

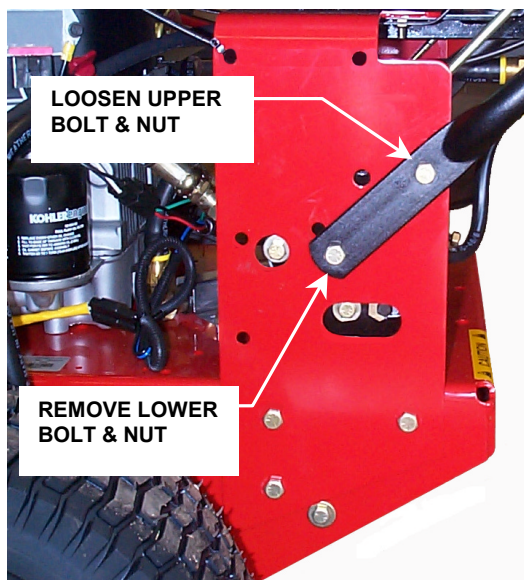

FIGURE 3.10

**STEP 6:** Pivot the Handlebar up or down and reinsert bolt and nut into desired hole position on each side. Tighten both upper and lower bolts and nuts on each side to 35 to 45 ft. lbs.

**STEP 7:** Adjust swivel (Clockwise or Counter-Clockwise) until the pin on the swivel aligns perfectly with the hole in the traction control arm. The traction control lever must be held in the Neutral Latch position when making this adjustment. Complete this adjustment for both left and right swivels. Carefully reattach and secure swivels to control arms. Tighten swivel jam nuts. **IMPORTANT:** Both the left and the right swivels must be installed in the same traction control arm speed range setting. Mid range (middle hole) setting is recommended.

**STEP 8:** Remove steel rod from shift lever arms.

**STEP 9:** Check to insure machine is securely blocked. Start engine. Drive wheels should not rotate with traction control levers latched in the Neutral position. If no rotation is observed the handlebar adjustment procedure is complete. If wheels do rotate proceed to next step. **STOP ENGINE.**

**STEP 10:** Wheel rotation will be stopped by adjusting the eccentric on the pump arms on the right and left pumps. Turning the eccentric slightly clockwise or counter-clockwise will synchronize the pump and traction controls for Neutral. See Figure 3.11. To turn the eccentric, first loosen the bolt in the pump control arm and the nut and bolt fastening the eccentric to the pump control arm. With traction controls latched in Neutral, start engine. Turn eccentric slightly clockwise or counter-clockwise until wheels stop rotating. Tighten control arm bolts and eccentric nut and bolts. Check for wheel rotation. Repeat eccentric adjustment if needed.

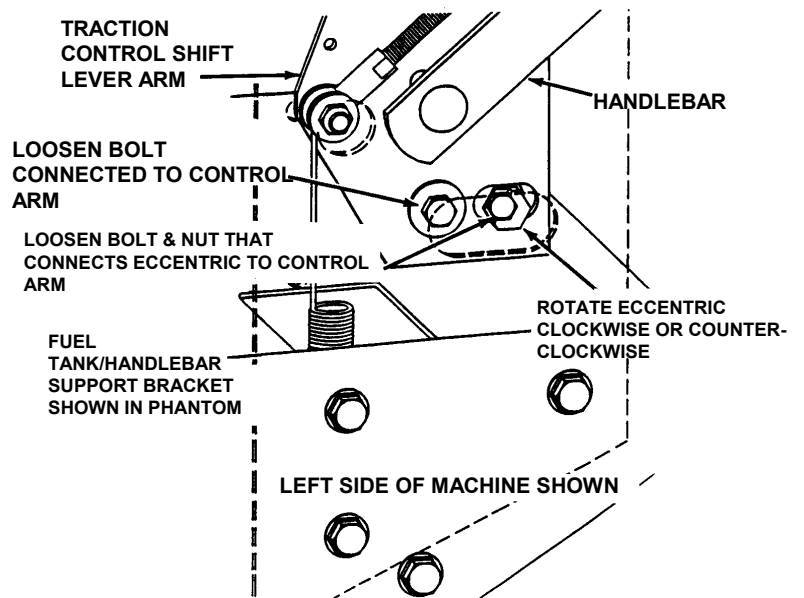

FIGURE 3.11

# SECTION 3 - OPERATING INSTRUCTIONS

## 3.8 CUTTING HEIGHT ADJUSTMENT

### (Fixed Decks)

The Mower has three methods of adjusting cutting height listed as follows:

1. Moving position of BLADE on cutter spindle shaft.
2. Moving position of CASTER WHEEL on support.
3. Moving position of MOWER DECK on power unit.

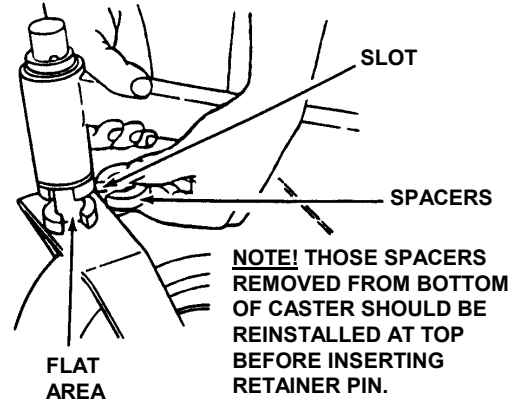

FIGURE 3.13

**WARNING**

DO NOT attempt any maintenance, adjustments or service with the engine running. Stop engine. Stop blades. Latch Traction Controls in neutral. Move Speed Control lever to SLOW. Remove key. Disconnect spark plug wires from spark plugs and secure wires away from spark plugs. Engine and components are HOT. Avoid serious burns by allowing all parts sufficient time to cool before working on machine.

## 3.9 ADJUSTING CASTER WHEELS

The Caster Wheel Assemblies have four (4) 1/2" and one (1) 1/4" thick Spacer. When placed above or below Caster Support Tube, the Operator can raise or lower the cutting height in 1/2" increments, thus providing a "Quick-Adjust" method. The deck mounting has to be changed to correspond with the Caster repositioning as described in Section "ADJUSTING FIXED MOWER DECK ATTACHMENT".

1. Remove the Retainer Pin from Caster Shaft. See Figure 3.12.

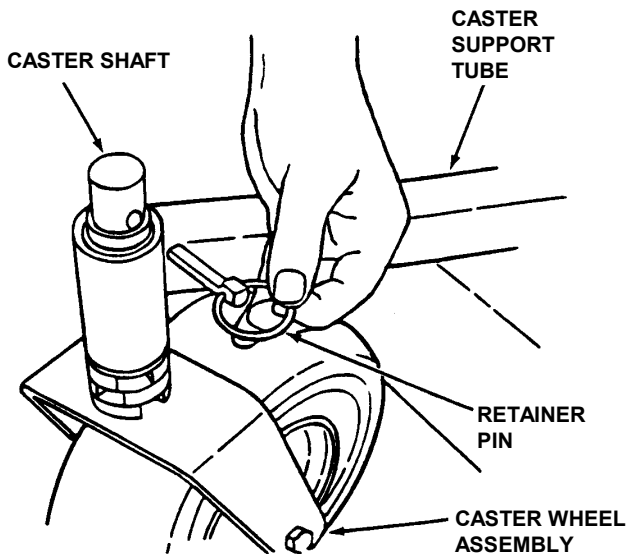

FIGURE 3.12

2. Lift Caster Support Tube while adding or removing the bottom Spacer. See Figure 3.13.

**NOTE:** Remove (or add) Spacers by rotating slots so they align with the flat area on Caster Shaft.

## 3.10 ADJUSTING BLADE ON CUTTER SPINDLE

To change cutting height of Blades, move the Spacers from under the Cutter Housing to above the Cutter Housing Pulley. Each Spacer moved above the Cutter Housing Pulley will provide an additional 1/4" of cutting height. DO NOT PUT ANY SPACERS BELOW BLADE! See Figure 3.14.

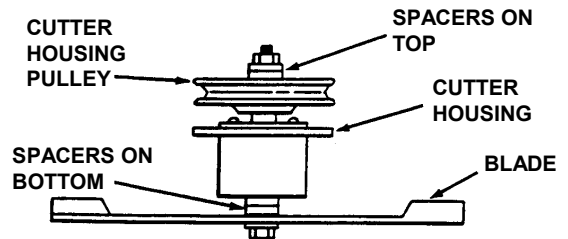

FIGURE 3.14

**NOTE:** Changing the cutting height of Blades DOES NOT change the Deck ground clearance. If an undesirable cutting pattern results, then cutting height adjustment MUST be made by adjusting Mower Deck height and Caster Wheels.

Install Blades (Air-Lift UP) with retaining hardware as shown below and tighten to 70-80 ft. lbs. See Figure 3.15.

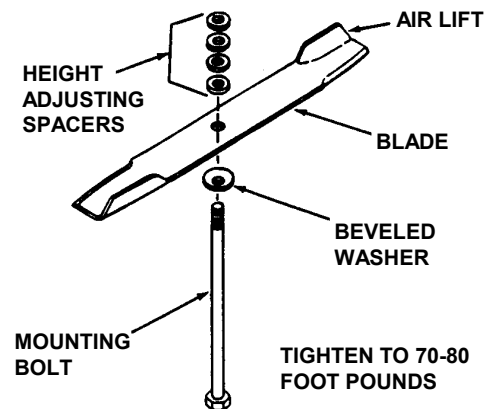

FIGURE 3.15

# SECTION 3 - OPERATING INSTRUCTIONS

## 3.11 ADJUSTING FIXED DECK ATTACHMENT

The Mower Deck has four different positions for attaching it to the power unit. The lowest setting provides a cutting height range from 1 1/2" to 2 1/2", the middle low cut from 2 1/4" to 3 1/4", the middle high cut from 3" to 4", and the highest cut from 3 3/4" to 4 3/4". Make sure the Spacers on the Caster Wheels are moved UP or DOWN as shown below to correspond with the bolt positions to keep the Mower Deck level. Once a desired cutting height is reached, attach the Mower Deck to the power unit by installing 3 bolts on each side in selected height of cut holes. Tighten the bolts from 70 to 80 foot pounds torque.

### SIDE PROFILE OF MACHINE

FIGURE 3.16A

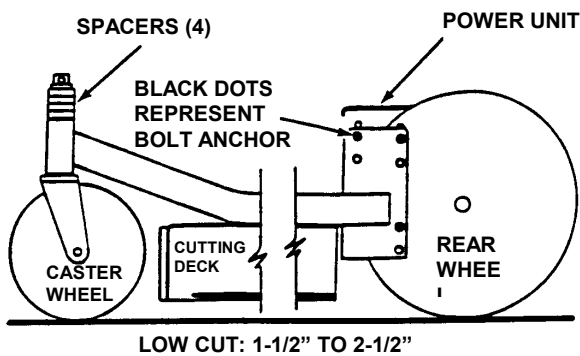

FIGURE 3.16B

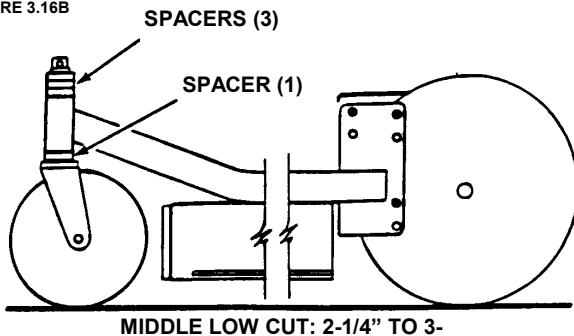

FIGURE 3.16C

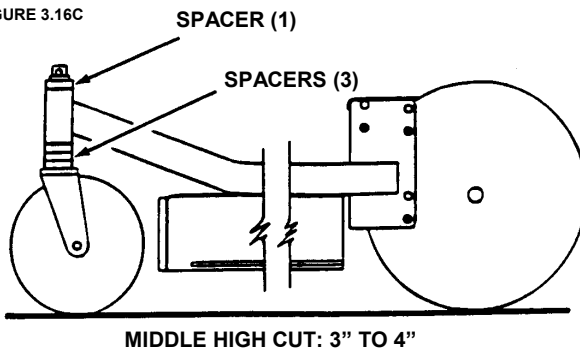

FIGURE 3.16 (A,B,C)

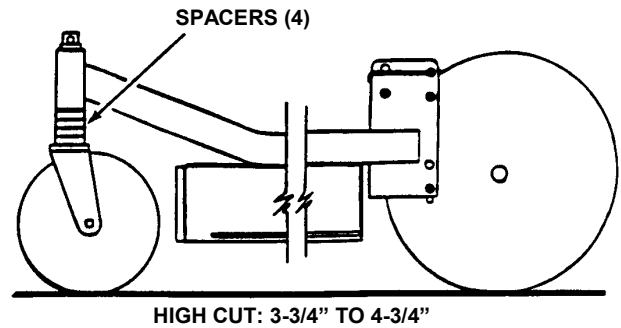

FIGURE 3.16 (D)

## 3.12 CUTTING HEIGHT ADJUSTMENTS FOR ADJUSTABLE DECK ATTACHMENTS

1. The Mower Deck should be mounted in the lowest holes (low cut) on the power unit.
2. To adjust height of cut, turn both Cranks (located on right hand and left hand side of deck) clockwise to raise the Mower Deck and counter-clockwise to lower the Mower Deck. Observe the height of cut decal located on the side of the Mower Deck mounting plates and move the height of cut pointers in the same desired position. See Figure 3.17.
3. If pointers are in the correct position and you still have an uneven cut, follow the instructions as listed below to correct the problem:
  - A. Rotate outer Blades to point toward the sides of the Mower Deck (make sure Mower is on level surface).
  - B. Measure the distance from Blade tip to the ground. Measure both outside Blades. This measurement should be the same as what the height of cut pointer reads on both sides.
  - C. If measurement is NOT the same, then bend both height of cut pointers UP or DOWN to read the same as Blade tip measurements.

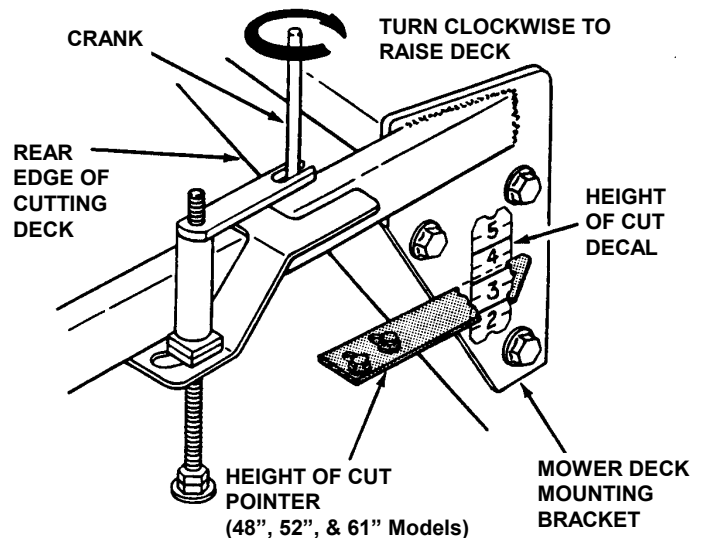

FIGURE 3.17

# SECTION 4 - ENGINE TROUBLESHOOTING

<b>SYMPTOM</b>	<b>PROBLEM</b>	<b>SOLUTION</b>	<b>PAGE</b>
<b>Engine does not start..</b>	Key OFF.	Turn Key to Run.	8
	Fuel Tank empty.	Fill Fuel Tank.	7
	Fuel Shut-Off Closed.	Open Fuel Shut-Off.	8
	Engine Throttle Control not at FAST (Rabbit) position.	Put Engine Throttle Control to FAST (Rabbit) position.	8
	Choke NOT closed.	Put Throttle Control in CHOKE position.	8
	Spark Plug Wire loose or disconnected.	Connect Spark Plug Wire.	(See Engine Manual)
	Blade Clutch Switch in ON position.	Move Blade Clutch switch to OFF position.	6
	Spark Plug bad.	Install new Spark Plug.	(See Engine Manual)
	Dirty Air Filter.	Clean Air Filter.	(See Engine Manual)
	Traction Controls not Latched in Neutral.	Move Traction Controls to NEUTRAL & Engage Neutral Latch Lever	8
<b>Engine Starts Hard or Loses Power.</b>	Dirt or water Fuel Tank.	Drain and clean Fuel Tank, fill with fresh Fuel.	7
	Air Filter dirty.	Clean or install new Air Filter.	(See Engine Manual)
	Spark Plug not gapped correctly.	Check and set Spark Plug gap.	(See Engine Manual)
	Spark Plug bad.	Install new Spark Plug.	(See Engine Manual)
<b>Engine Runs Erratically.</b>	Spark Plug bad.	Install new Spark Plug.	(See Engine Manual)
	Spark Plug not gapped correctly.	Check and gap spark plug gap.	(See Engine Manual)
	Fuel Filter plugged or dirty.	Replace Fuel Filter.	
<b>Engine Idles Poorly.</b>	Dirty Air Filter.	Clean or replace Filter.	(See Engine Manual)
	Fuel Filter plugged	Replace Fuel Filter.	
<b>Engine Overheats.</b>	Engine Oil low in Crankcase.	Add Oil.	(See Engine Manual)
	Cooling Fins & Flywheel Screen Clogged.	Clean Fins & Screen	
<b>Machine Vibrates Excessive.</b>	Blade Mounting Bolts loose.	Tighten Blade Mounting Bolts.	12, 21
	Blade out of balance.	Sharpen and balance Blade.	21
	Engine Mounting Bolts loose.	Tighten Mounting Bolts.	(See Engine Manual)
<b>Engine Dies.</b>	Mowing grass too tall.	Adjust cutting height.	12, 13
	Mowing too fast.	Reduce travel speed.	9

# SECTION 4 - SERVICE & LUBRICATION INFORMATION

**IN-LINE FUEL FILTER**  
(Not Illustrated)  
Replace every 100

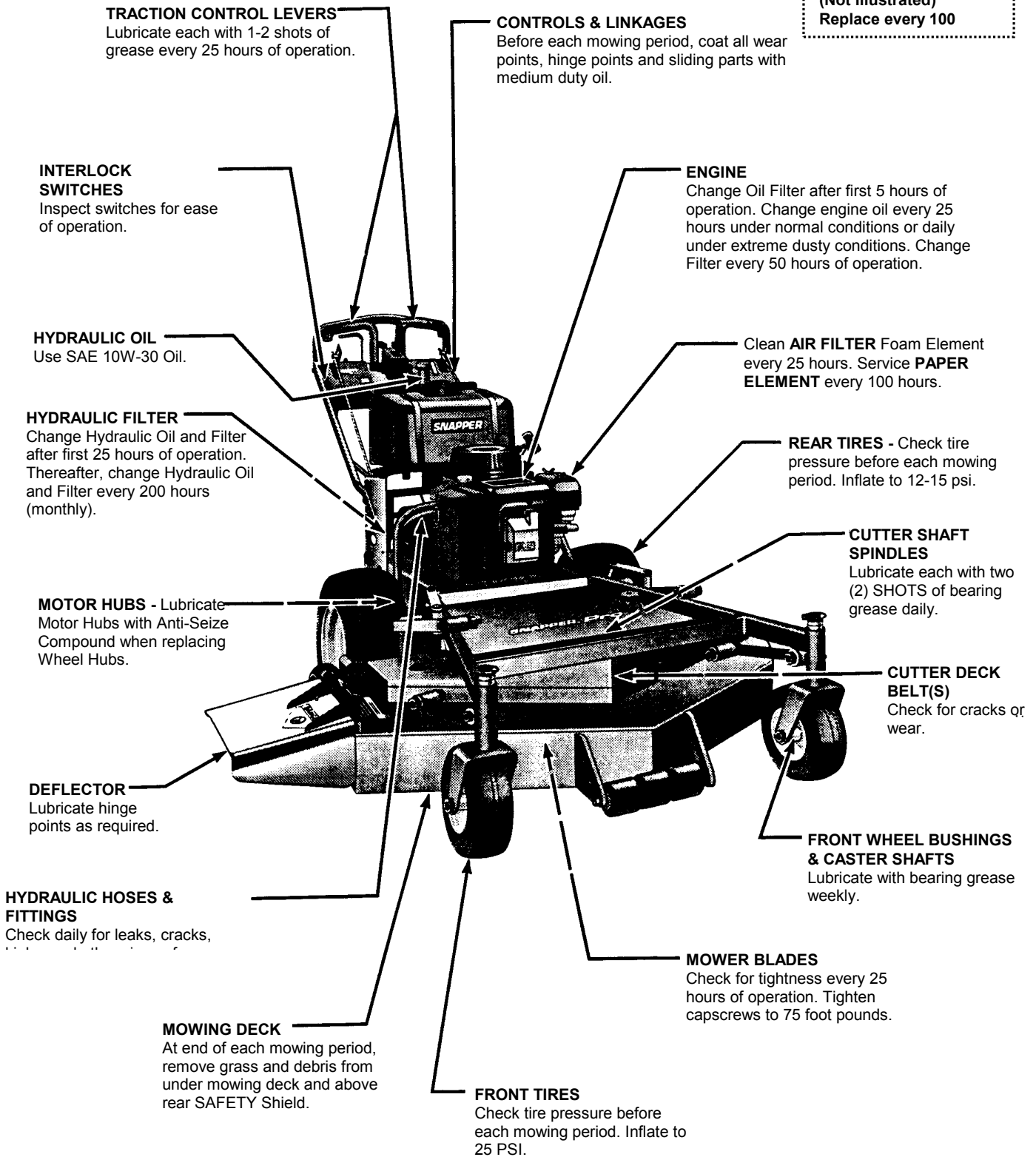

FIGURE 4.1

# SECTION 4 - SERVICE & LUBRICATION INFORMATION

HOURS	PROCEDURE	COMMENTS
BREAK-IN	Check all fasteners for proper tightness Change Engine Oil and Filter at 5 hours ..... Change Hydraulic Oil and Filter at 25 hours .....	See engine manual Use SAE 10W-30. Reservoir capacity 1 Gal.
8 HOURS (Daily)	Check/Change Engine Oil ..... Clean Air Filter..... Clean Blower screen ..... Remove Debris from under Belt Cover ..... Sharpen Cutter Blades ..... Grease Cutter Spindle Bearings..... Check Hydraulic Reservoir.....	Change oil if extreme dusty conditions More often if needed More often if needed More often if needed Tighten Cap Screw to 70 - 80 ft. lbs. Use Chevron SRI Grease (NLGI2). Add oil if needed
40 HOURS (Weekly)	Check Tire Pressure ..... Check Safety Interlock System ..... Grease Traction Control Levers ..... Inspect Traction Lock for Wear..... Change Engine Oil ..... Replace Air Filter..... Grease Caster Wheel Bearings ..... Grease Caster Wheel Pivot..... Grease Idler Arm Pivots .....	Add or adjust as Required Inspect Switches for ease of Operation General Purpose Grease Replace if Worn More often if needed More often if needed General Purpose Grease General Purpose Grease General Purpose Grease
200 HOURS (Monthly)	Fuel Filter ..... Check all Fasteners for Proper tightness ..... Change Engine Oil Filter ..... Clean and Adjust Spark Plugs ..... Check Belt Tension ..... Lube Controls and Linkages ..... Change Hydraulic Oil and Filter .....	Replace with Snapper P/N 1-4359 See Torque Specifications See Engine Manual See Engine Manual See Operator's Manual Use Medium Duty Oil Use SAE 10W-30 Oil. Reservoir capacity 1 Gal.

GREASE ZERK LOCATION	GREASE DAILY	GREASE WEEKLY
1 on the Hydro Pump Belt Idler Arm Pivot		X
1 on each Spindle Housing (Total of 2 on 36" Deck & 3 on 48", 52", 48", & 61" Decks)	X	
1 on each Idler Arm Pivot (Total of 1 on 36" Deck & 2 on 48", 52", 48", & 61" Decks)		X
1 on each Caster Support Arm (Total of 2)		X
1 on each Caster Wheel (Total of 2)		X
1 on each Traction Control Lever (Total of 2)		X

## MAINTENANCE/REPLACEMENT PARTS

MAINTENANCE PARTS	
36" Cutter Blade (Requires Two Blades)	2-9246
48" Cutter Blade (Requires Three Blades)	2-9247
52" Cutter Blade (Requires Three Blades)	2-9246
61" Cutter Blade (Requires Three Blades)	2-9251
36" Deck Engine to Cutting Deck Belt	2-9255
48" Deck Engine to Cutting Deck Belt	2-9262
48" Deck Spindle to Spindle Belt	2-9261
52" Deck Engine to Cutting Deck Belt	2-9267
52" Deck Spindle to Spindle Belt	2-9266
61" Deck Engine to Cutting Deck Belt	2-9269
61" Deck Spindle to Spindle Belt	2-9268
Parts Manual for Pro Hydro Series 1	06926



# SECTION 4 - SERVICE

**⚠ WARNING ⚠**

Once blades are disengaged, they should come to a complete stop in 7 seconds or less. If the blades continue to rotate after 7 seconds, the electric clutch must be checked. Replacement of electric clutch may be necessary. Return machine to dealer for replacement. **DO NOT CONTINUE** to operate mower if blades fail to stop in 7 seconds.

## 4.1 ELECTRIC CLUTCH ADJUSTMENT

The Pro Hydro Mowers are equipped with an Electric Blade Control. The cutter blades should STOP within 7 seconds after the BLADE SWITCH is moved to "OFF" position. If blade stopping time exceeds 7 seconds, check the clutch air gap setting as follows:

1. With the Ignition Switch moved to "STOP" and the Blade Switch moved to "OFF", locate the three air gap check "SLOTS" as shown in Figure 4.2.

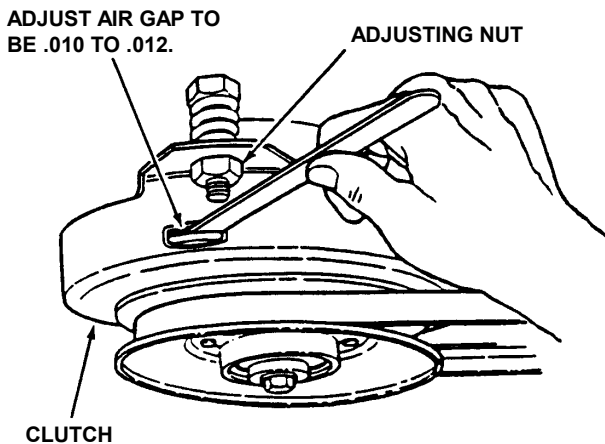

FIGURE 4.2

2. Insert a feeler gauge into each of the three slots.
3. The clearance in each slot should be NO MORE than .010 to .012.
4. If adjustment is required, keep feeler gauge in slot and turn the adjusting nut until the gap is correct.
5. Adjust all three slots.

## 4.2 HYDRAULIC SYSTEM ADJUSTMENTS & SERVICE

### 4.2.1. GENERAL HYDRAULIC SERVICING

1. The Hydraulic Oil and Filter should be changed after the initial 25 hours of use and after every 200 hours of use. Drain both compartments of the hydraulic reservoir completely. Replace filter using genuine Snapper replacement only. Fill reservoir using 1 gallon of SAE10W-30 oil. Operate machine for several minutes. Check oil level. Reservoir is properly filled when level is 1-1/2" from the top of the filler neck. See Figure 3.1.

**NOTE:** Always clean the Cap and surrounding area before checking Oil Level or adding Oil. The Hydraulic Oil Tank is FULL when the Oil is 1-1/2" from the top of the filler neck as shown in Figure 3.1.

2. Before removing parts from the Hydraulic System, check to make sure another part of the machine is not causing the problem. Look for:

- A. Loose Drive Belt.
- B. Improperly set or bad Idler Pulley.
- C. Loose or lost set screws and/or sheared Keys in Pulleys.
- D. Pump Release loose.
- E. Oil saturated Drive Belts.
- F. Loose Drive Arms on Pumps.

### 4.2.2. PUMP/MOTOR REPLACEMENT

1. Should it become necessary to replace a Pump or Motor, it is recommended that the affected Pump or Motor be replaced as a set (both Pump and Motor). Generally, when a Pump or Motor is bad, it will affect the associated Pump or Motor.
2. Relieve all pressure in the system and disconnect Spark Plug(s). See Figure 4.3.
3. Replace the affected component(s).

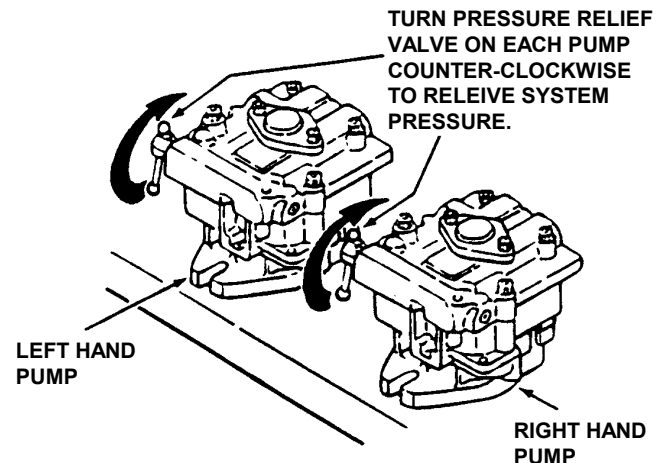

FIGURE 4.3

### 4.2.3. HYDRAULIC PUMP BELT REMOVAL

1. STOP ENGINE! Loosen and remove Nut from under the Spring Tensioner for Hydraulic Belt Idler Tensioner. Remove Spring from Bolt. See Figure 4.4.

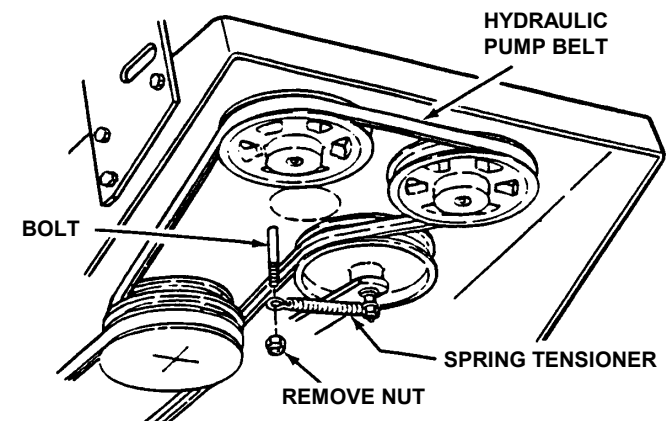

FIGURE 4.4

## SECTION 4 - SERVICE

### 4.2.3. HYDRAULIC PUMP BELT REMOVAL (Continued)

2. Loosen Nut on Belt Guide at rear of Engine Pulley and remove Cutter Deck Belt from Engine Pulley.
3. Remove Hydraulic Pump Belt.

### 4.2.4. HYDRAULIC PUMP BELT INSTALLATION

1. STOP ENGINE! Place Hydraulic Belt on Engine and Pump Pulleys.
2. Attach Idler Spring to Bolt and reattach Nut to Bolt.
3. Place Cutter Deck Belt on Engine Pulley.

### 4.2.5. REPLACEMENT PARTS

To retain the quality of your Machine, use genuine SNAPPER replacement parts only. Contact your local SNAPPER Dealer for parts and service and service assistance. For the correct part or information for your Machine, always mention Model and Serial Number of Power Unit and mower Attachment. We recommend returning your Machine to an authorized SNAPPER Dealer on a yearly basis for inspection and addition of any new devices which might upgrade the performance and SAFETY of your Machine. For the nearest SNAPPER Dealer, check the yellow pages under the heading, LAWN MOWERS. For Engine Parts and Service, look for the Engine Manufacturer's Dealers under the heading, ENGINES - GASOLINE.

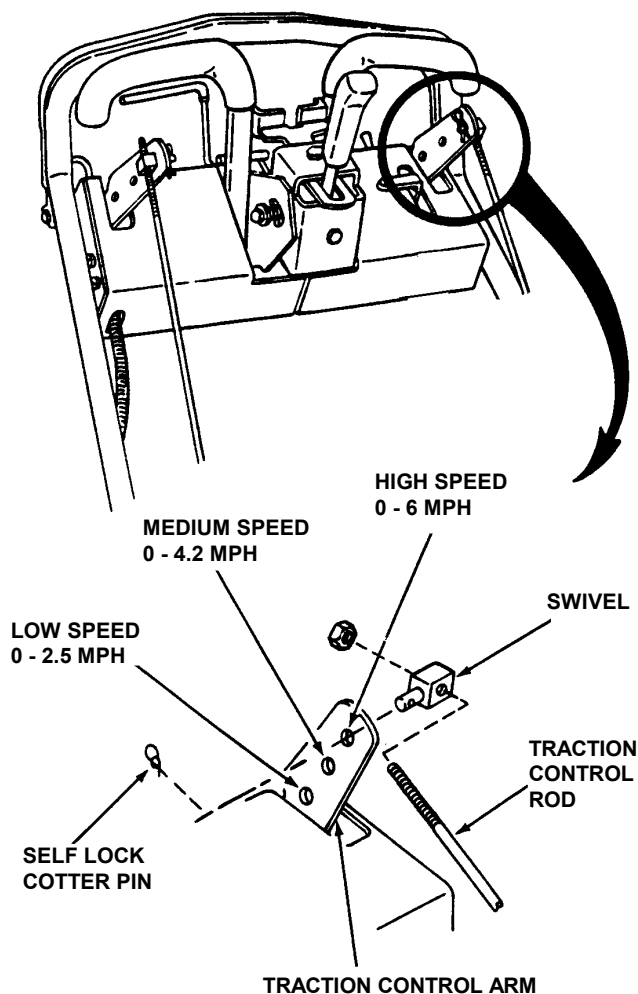

FIGURE 4.5

**WARNING**  
DO NOT attempt any maintenance adjustments or service with the engine running. Stop engine. Stop blades. Latch Traction Controls in neutral. Move Speed Control lever to SLOW. Remove key. Disconnect spark plug wires from spark plugs and secure wires away from spark plugs. Engine and components are HOT. Avoid serious burns by allowing all parts sufficient time to cool before working on machine.

**NOTE:** All Mid-Size Machines should be tilted with Engine Carburetor side UP.

## 4.3 MACHINE SPEED CONTROL RANGES

### 4.3.1. TO CHANGE MACHINE SPEED RANGES



1. Move Traction Control Levers and Neutral Latch Lever into neutral.
2. Turn Key to STOP position and remove Key from Ignition Switch.
3. Remove Hairpins from Swivels on Traction Control Arms on Right and Left Hand side. See Figure 4.5.
4. Push Swivel out from each Traction Control Arm and insert Swivel into newly selected speed range. (No adjustment should be necessary to maintain neutral setting after changing speed range.) If machine does require adjustment Refer to Section "TRACTION CONTROL NEUTRAL ADJUSTMENT".
5. Start the Engine and resume using the Machine at the newly selected speed range.

**WARNING**  
The SNAPPER Pro Hydro Mowers have a Transport Speed, which allows the machine to travel forward at a speed of 6 MPH - it is NOT to be used while walking! Use the Transport Speed ONLY when the machine is equipped with a Riding Sulky! DO NOT make sharp turns at high speed! The machine has "zero-turn" capability; DO NOT use "zero-turn" at high speed. During initial training time with machine, it is advised that the Operator(s) practice with the Speed Control Lever in the slowest travel speed position and Blade Engagement Switch in the OFF position

## SECTION 4 - SERVICE

### 4.4 TRACTION CONTROL NEUTRAL ADJUSTMENT

The Traction Control Neutral Adjustment procedure is sensitive. The following steps and WARNINGS must be followed very carefully.

	<b>WARNING</b>	
<p><b>Several steps of the Neutral Adjustment procedure require that the engine be started. Exercise extreme CAUTION while making adjustments while engine is running to avoid HOT engine components, rotating components, run over or entrapment types of injuries.</b></p>		

**IMPORTANT:** To complete this procedure a steel rod 5/16" diameter and 20" long will be required. DO NOT begin this procedure without it.

1. Place machine on smooth level surface. Stop engine and remove keys.
2. Raise rear of machine just high enough for rear wheels to clear ground. Block machine securely.
3. Latch Traction Controls in Neutral.
4. Insert rod (5/16" diameter x 20" long) through alignment holes in the left and right traction control shift lever arms and the tank support bracket. The rod should pass through both the left and right traction control shift lever arms. See Figure 3.9.
5. Disconnect left & right swivels from the left and right traction control arms and loosen swivel jam nuts. See Figure 3.8.
6. Adjust swivel (Clockwise or Counter-Clockwise) until the pin on the swivel aligns perfectly with the hole in the traction control arm. The traction control lever must be held in the Neutral Latch position when making this adjustment. Complete this adjustment for both left and right swivels. Carefully reattach and secure swivels to control arms. Tighten swivel jam nuts. **IMPORTANT:** Both the left and the right swivels must be installed in the same traction control arm speed range setting. Mid range (middle hole) setting is recommended.
7. Remove steel rod from shift lever arms.
8. Check to insure machine is securely blocked. Start engine. Drive wheels should not rotate with traction control levers latched in the Neutral position. If no rotation is observed the adjustment procedure is complete. If wheels do rotate proceed to next step. STOP ENGINE.

9. Wheel rotation will be stopped by adjusting the eccentric on the pump arms on the right and left pumps. Turning the eccentric slightly clockwise or counter-clockwise will synchronize the pump and traction controls for Neutral. See Figure 3.11. To turn the eccentric, first loosen the bolt in the pump control arm and the nut and bolt fastening the eccentric to the pump control arm. With traction controls latched in Neutral, start engine. Turn eccentric slightly clockwise or counter-clockwise until wheels stop rotating. Tighten control arm bolts and eccentric nut and bolts. Check for wheel rotation. Repeat eccentric adjustment if needed.

# SECTION 5 - MOWER ATTACHMENT SERVICE

## 5.1 CUTTER DECK BELT REMOVAL & INSTALLATION

### 5.1.1. 36" CUTTING DECK BELT REMOVAL

1. Move Mower onto a smooth, level surface. Turn Ignition Key to STOP position, remove Key, disconnect Spark Plug Wire and secure Wire away from Spark Plug.
2. Remove Mower deck belt cover.
3. Remove Idler Tension Spring and swing Idler away from belt.
4. Remove old belt from Spindle Pulleys and Electric Clutch Pulley. See Figure 5.1.

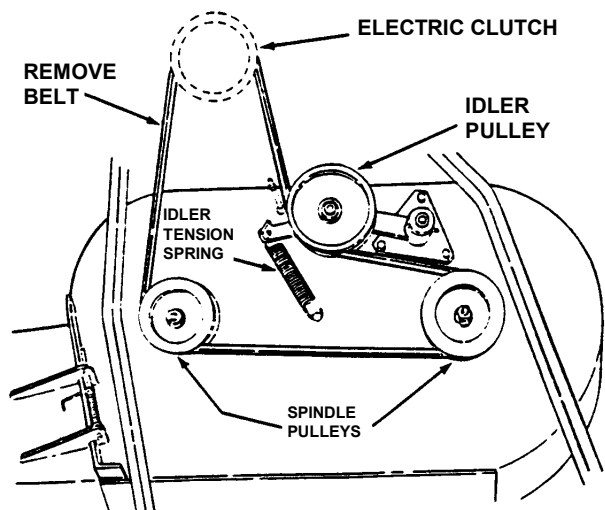

FIGURE 5.1

### 5.1.2. 36" CUTTING DECK BELT INSTALLATION

1. Route new belt to Electric Clutch Pulley.
2. Route new belt around Spindle Pulleys as shown in Figure 5.1.
3. Move Idler against belt and reattach Idler Tension Spring.

### 5.1.3. 48", 52", & 61" CUTTING DECK BELT REMOVAL

1. Move Mower onto a smooth, level surface. Turn Ignition Key to STOP position, remove Key, disconnect Spark Plug Wire and secure Wire away from Spark Plug.
2. Remove Mower deck belt cover.
3. Remove right hand Idler Tension Spring and swing Idler away from belt. See Figure 5.2.

### 5.1.4. 48", 52", & 61" CUTTING DECK BELT INSTALLATION

1. Route new belt for 48" cutting deck, for 52" cutting deck, and for 61" cutting decks, to Electric Clutch Pulley.

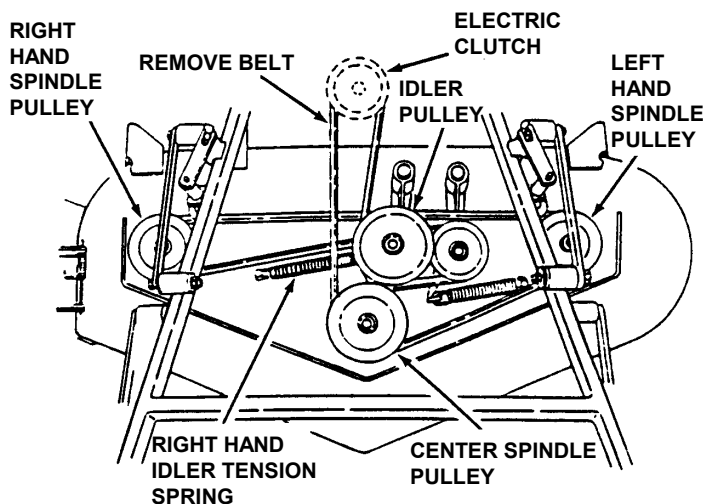

FIGURE 5.2

2. Route new belt around right and left hand Spindle Pulleys as shown in Figure 5.2.
3. Move Idler against belt and reattach right hand Idler Tension Spring.

### 5.1.5. SPINDLE TO SPINDLE DECK BELT REMOVAL - 48", 52", & 61" CUTTING DECKS

1. Move Mower onto a smooth, level surface. Turn Ignition Key to STOP position, remove Key, disconnect Spark Plug Wire and secure Wire away from Spark Plug.
2. Remove Mower deck belt cover.
3. Remove right hand Idler Spring and swing Idler away from belt.
4. Remove old belt from center and right hand Spindle Pulleys. See Figure 5.2.
5. Remove Left hand Idler Spring and swing Idler away from belt.
6. Remove old belt from left hand Spindle Pulley and center Pulley bottom groove. See Figure 5.3.

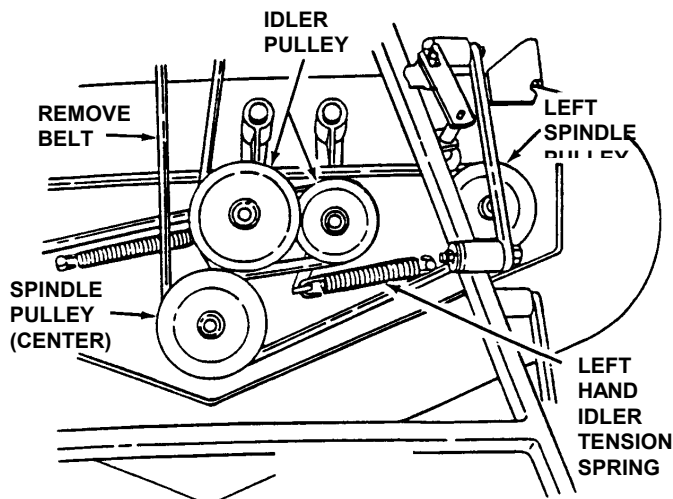

FIGURE 5.3

# SECTION 5 - MOWER ATTACHMENT SERVICE

## 5.1.5. SPINDLE TO SPINDLE DECK BELT INSTALLATION - 48", 52", & 61" CUTTING DECKS

1. Route new belt for 48" cutting deck, 52" cutting deck, and 61" cutting decks, onto bottom groove of center Spindle Pulley and left hand Spindle Pulley. See Figure 5.3.
2. Install cutting deck belt according to CUTTING DECK BELT INSTALLATION.

## 5.2 CUTTING BLADE SERVICE

Check Blades at frequent intervals to insure they are securely tightened and in good condition. Replace if chipped, bent, or notched. See Figure 5.4 for Blade wear limits.

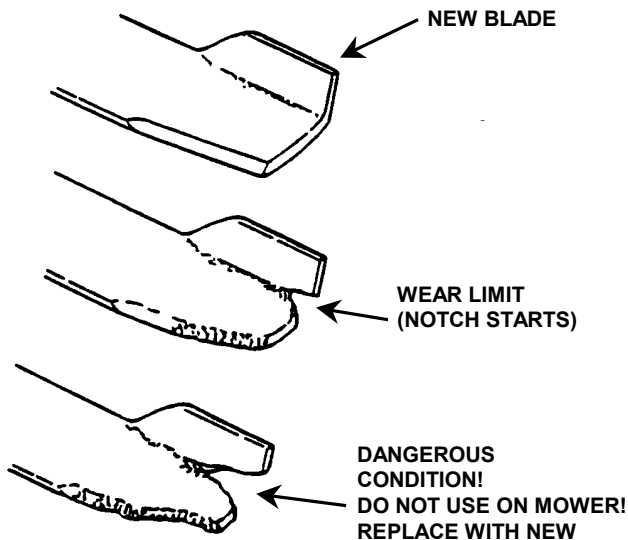

FIGURE 5.4

1. Use the following chart for ordering replacement Blades for the 36", 48", 52" and 61" cutting decks.

STANDARD BLADE REPLACEMENT			
36" DECK	48" DECK	52" DECK	61" DECK
2-9246	2-9247	2-9246	2-9251

### 5.2.1. BLADE REMOVAL AND SHARPENING

1. Move the Mower to a smooth, level surface, turn the Ignition Key to STOP position, remove Key, disconnect Spark Plug Wire from Spark Plug and secure Wire away from Plug.
2. Remove Blades.

**WARNING**

Take NOTE of the number of Blade Spacers that are under the Blade Mounting Nuts and on the Spindle side of the Blade.

3. Clean and inspect each Blade for excessive wear and damage. See Figure 5.4 for Blade wear limits.

4. Refer to the STANDARD REPLACEMENT BLADES chart above for correct SNAPPER replacement Blades.
5. Should Blades be in acceptable condition, sharpen at 22 to 28 degrees. See Figure 5.5.

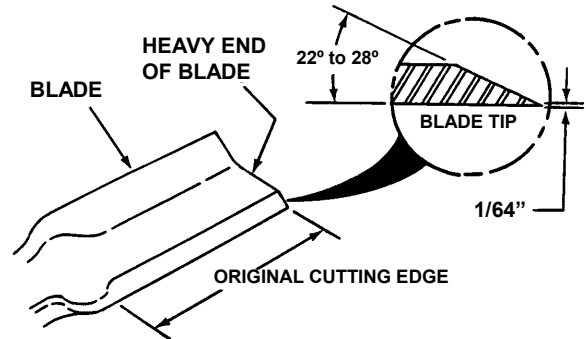

FIGURE 5.5

**NOTE:** When sharpening Blades, leave 1/64" untouched. Razor sharp Blades will chip easily and dull quickly. Commercial balancers are available and should be used in accordance with the manufacturer's instructions.

6. Balance each Blade after sharpening by grinding metal from the heavy end of the blade.
7. Place the Blade mounting bolt into Blade and place Blade spacers over bolt. Make certain each blade is installed with the same amount of spacers removed.
8. Install Blade mounting bolt with spacers and blade into spindle.
9. Install an equal amount of Blade spacers onto each Blade mounting bolt.
10. Install the Blade mounting nut on each Blade mounting bolt. See Figure 5.6.
11. Torque each Blade mounting bolt and nut to 70 - 80 foot-pounds.

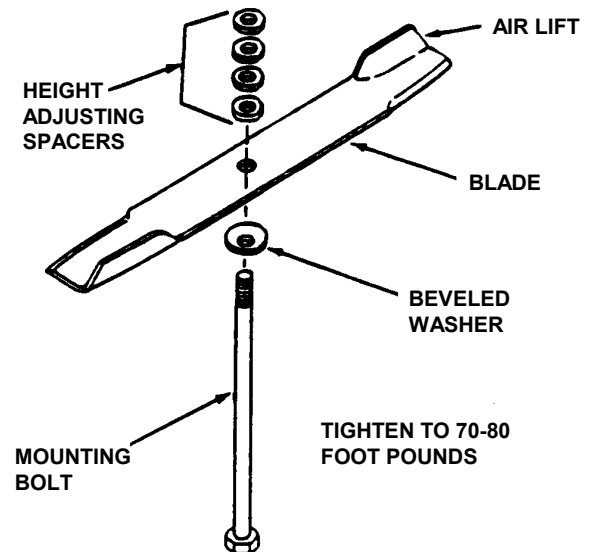

FIGURE 5.6

## SECTION 5 - MOWER ATTACHMENT SERVICE

### 5.3 MOWER SPINDLES (Field Serviceable Spindles) BEARING REPLACEMENT

In the event that a spindle bearing requires replacement, the SNAPPER Field Serviceable Spindles have been designed so that no special tools or presses are required.

1. Remove belt. Loosen blade nut and remove. Allow blade bolt, washer, blade and four spacers to drop down out of the spindle housing. See Figure 5.7.

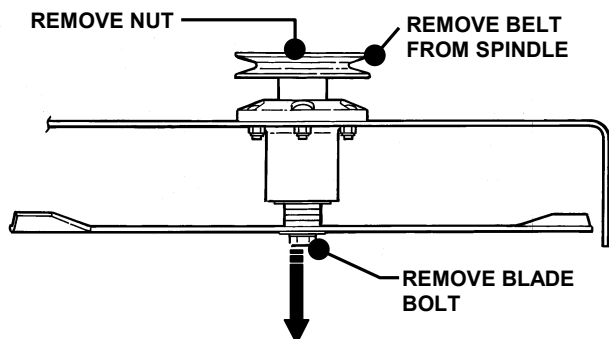

FIGURE 5.7

2. Remove spindle pulley from spindle shaft.  
3. Locate circular retaining ring on spindle shaft at top bearing. Remove retaining ring. Allow spindle shaft to drop out of housing.  
4. Top and bottom bearings are now removable. Pull out on inner race to slide bearing from housing. See Figure 5.8.

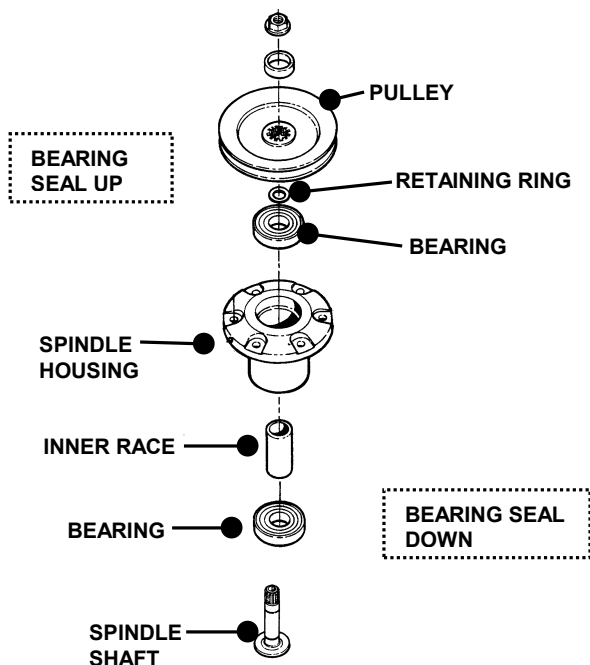

FIGURE 5.86

5. Thoroughly clean all parts removing all old contaminated grease.  
6. Install new bottom bearing first.

**NOTE:** The bearing is sealed/shielded on one side only. The bottom bearing must be installed with the sealed/shielded side DOWN.

7. Insert spindle shaft up through the bottom bearing. Slide spacer down over spindle shaft.  
8. Install new top bearing. Install the top bearing with the seal/shield UP.  
9. Slide circular retaining ring down spindle shaft until it fully locks into groove on shaft.  
10. Place spindle pulley and spacer on top of spindle shaft.  
11. Reinstall blade bolt, washer, blade and four spacers.  
12. Torque blade bolt and nut to 60 to 75 ft. lbs.

**IMPORTANT:** Spindle housing must be filled with grease before operating mower. Failure to fill housing will cause premature bearing failure.

13. Pump grease into spindle housing until grease purges from vent on housing.  
14. After the first 5 hours of operation, grease spindle housing to insure it is full, then every 25 hours.

## SECTION 6 - BATTERY SERVICE & TESTING

**WARNING**

Shield the positive terminal with terminal cover located on battery harness. This prevents metal from touching the positive terminal, which could cause sparks. Cables must be connected to battery terminals in the proper position. RED (Positive) cable must go to the ( + ) terminal. BLACK (Negative) cable must go to the ( - ) terminal.

### 6.1 BATTERY REMOVAL

1. Remove battery retainer.
2. Slide terminal cover away from positive terminal.
3. Observe and note cable positions on battery
4. Disconnect cables from battery terminals, disconnecting BLACK (Negative) cable first, then disconnect RED (Positive) last. Retain mounting bolts and nuts.

### 6.2 BATTERY INSTALLATION

1. Position battery into battery compartment.
2. Connect cables to battery terminals. Connect RED (Positive) cable first. Connect BLACK (Negative) cable last.
3. Reinstall battery retainer and positive terminal cover.

### 6.3 BATTERY SERVICE

1. Remove battery.
2. Place battery in a well ventilated area on a level surface.
3. Using distilled water, refill cells as required to cover cell plates of which can also be seen through the plastic battery case.

4. With cell caps removed, connect battery charger to battery terminals. RED to positive (+) terminal and BLACK to negative (-) terminal.
5. Slow charge battery at 1 amp for 10 hours. An alternative fast charge should be no more than 2.5 amps for four hours.
6. If battery will not accept charge or is partially charged after 10 hours of charging at 1 amp, replace with new battery.

**WARNING**

The electrolyte (acid) produces a highly explosive gas. Keep all sparks, flame and fire away from area when charging battery or when handling electrolyte or battery. Electrolyte (acid) is a highly corrosive liquid. Wear eye protection. Wash affected areas immediately after having eye or skin contact with electrolyte (acid). Battery acid is corrosive. Rinse empty acid containers with water and mutilate before discarding. If acid is spilled on battery, bench, or clothing, etc., Flush with clear water and neutralize with baking soda.

<b>Battery Condition Chart</b>			
State of Charge	Syringe Hydrometer	Digital Voltmeter	Five Ball Hydrometer
100% Charged w/ Sulfate Stop	1.280	12.80v	Five Balls Floating
100% Charged	1.265	12.60v	Four Balls Floating
75% Charged	1.210	12.40v	Three Balls Floating
50% Charged	1.160	12.10v	Two Balls Floating
25% Charged	1.120	11.90v	One Ball Floating
0% Charged	Less than 1.100	Less than 11.80v	Zero Balls Floating

### 6.4 BATTERY TESTING

There are two types of battery tests: Unloaded and Loaded. The unloaded test is the procedure that will be discussed. It's the simplest and most commonly used. An unloaded test is made on a battery without discharging current. To perform unloaded testing, check charge condition using either a hydrometer or voltmeter.

1. Using a voltmeter, voltage readings appear instantly to show the state of charge. Remember to hook the positive lead to the battery's positive terminal, and the negative lead to the negative terminal.
2. A hydrometer measures the specific gravity of each cell. The specific gravity tells the degree of charge;

generally, a specific gravity of about 1.265 to 1.280 indicates full charge. A reading of 1.230 to 1.260 indicates the battery should be charged before testing. The chart on the next page shows the charge level as measured by syringe float hydrometer, digital voltmeter and five ball hydrometer.

## SECTION 6 - BATTERY SERVICE & TESTING

### 6.5 NEW BATTERY PREPARATION

1. Remove battery from carton.
2. Place battery in a well ventilated area on a level non-concrete surface.
3. Remove battery cell caps. Fill cells as required with electrolyte (purchased separately) to proper level. Fill to 3/16" above cell plates. Filling battery with electrolyte will bring the battery to 80% charged state.
4. With cell caps removed, connect battery charger to battery terminals; RED to positive (+) and BLACK to negative (-) terminal.

**IMPORTANT:** 3/16" above cell plates is the recommended level. DO NOT place anything in battery other than specified electrolyte.

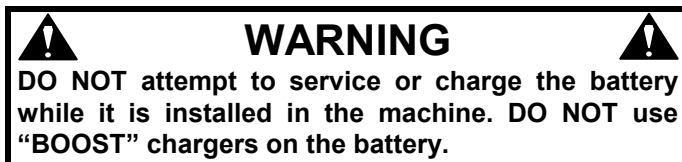

5. Slow charge the battery at 1 amp for 2 hours to bring the battery to full charge.
6. After charging, check level of electrolyte and add as needed to bring level to 3/16" above cell plates.
7. Reinstall cell caps.
8. Install battery into power unit.
9. Connect positive (+) cable (red) first, from wiring harness to the positive terminal (+) on battery using bolt and nut provided in hardware bag. Connect negative (-) cable (black) last, to negative terminal (-) on battery using bolt and nut. Apply a small amount of grease over terminals to prevent corrosion.
10. Install battery retainer and positive terminal cover.

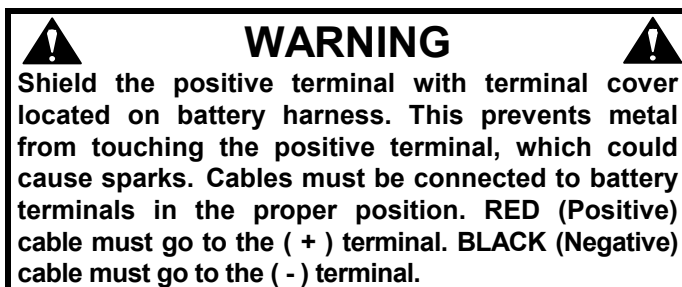



# **SNAPPER®**

## **2 YEAR LIMITED WARRANTY**

For two (2) years from purchase date for the original purchaser's use, **SNAPPER**, through any authorized **SNAPPER** dealer will replace, free of charge (except for taxes where applicable), any part or parts found upon examination by the factory at McDonough, Georgia, to be defective in material or workmanship or both.

**SNAPPER** FIELD SERVICEABLE SPINDLES and their components used on **SNAPPER PRO**® Mid Size walks and **SNAPPERZRIDER**® ride on commercial equipment have a three (3) year limited warranty against defects in material or workmanship or both.

All transportation costs incurred by the purchaser in submitting material to an authorized **SNAPPER** dealer for replacement under this warranty must be paid by the purchaser.

This warranty does not apply to engines and their components, and batteries, as these items are warranted separately. This warranty does not apply to parts that have been damaged by accident, alteration, abuse, improper lubrication, normal wear, or other cause beyond the control of **SNAPPER**. This warranty does not cover any machine or component that has been altered or modified, changing safety, performance, or durability.

Batteries have a one (1) year prorated warranty period with free replacement if required during the first ninety (90) days from the original purchase date. **SNAPPER** will not be responsible for any installation cost incurred. The battery warranty only covers original equipment batteries and does not cover damage to the battery or machine caused by neglect or abuse, destruction by fire, explosion, freezing, overcharging, improper maintenance, or use of improper electrolyte.

There is no other express warranty.

### **DISCLAIMER OF WARRANTY**

Implied warranties, including those of merchantability and fitness for a particular purpose, are limited to two (2) years from purchase date for the original purchaser's use, and up to the extent permitted by law and all implied warranties are excluded. This is the exclusive remedy. Liabilities for consequential damages, under any and all warranties are excluded.

Some states do not allow limitations on how long an implied warranty lasts, or do not allow the exclusion or limitation of incidental or consequential damages, so the above limitation or exclusion may not apply to you.

This warranty gives you specific legal rights, and you may also have other rights which vary from state to state.

**WARNING: THE USE OF REPLACEMENT PARTS OTHER THAN GENUINE SNAPPER PARTS MAY IMPAIR THE SAFETY OF SNAPPER PRODUCTS AND WILL VOID ANY LIABILITY AND WARRANTY BY SNAPPER ASSOCIATED WITH THE USE OF SUCH PARTS.**

**IMPORTANT:** Please fill out the attached **SNAPPER** Product Registration Card immediately and mail to:  
**Snapper's Product Registration Center, P.O. Box 1379, McDonough, Georgia. 30253**

PRIMARY MAINTENANCE

# SNAPPER®

## vs. DIRT!

an illustration of how dirt can damage your engine & how reasonable maintenance can protect it!

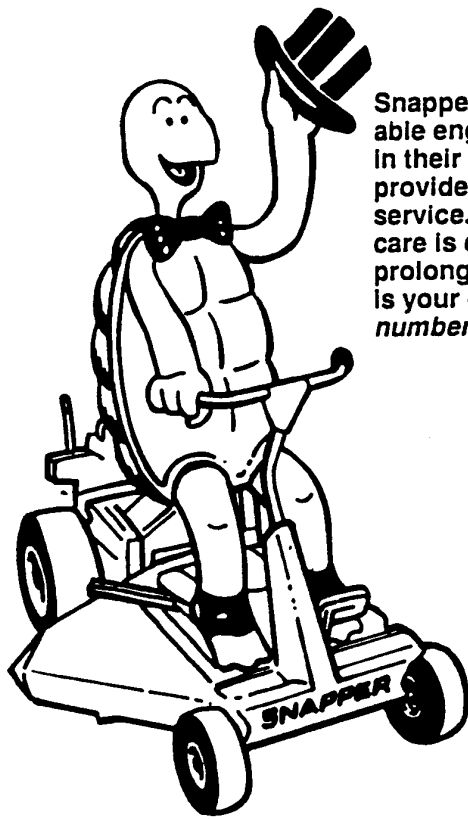
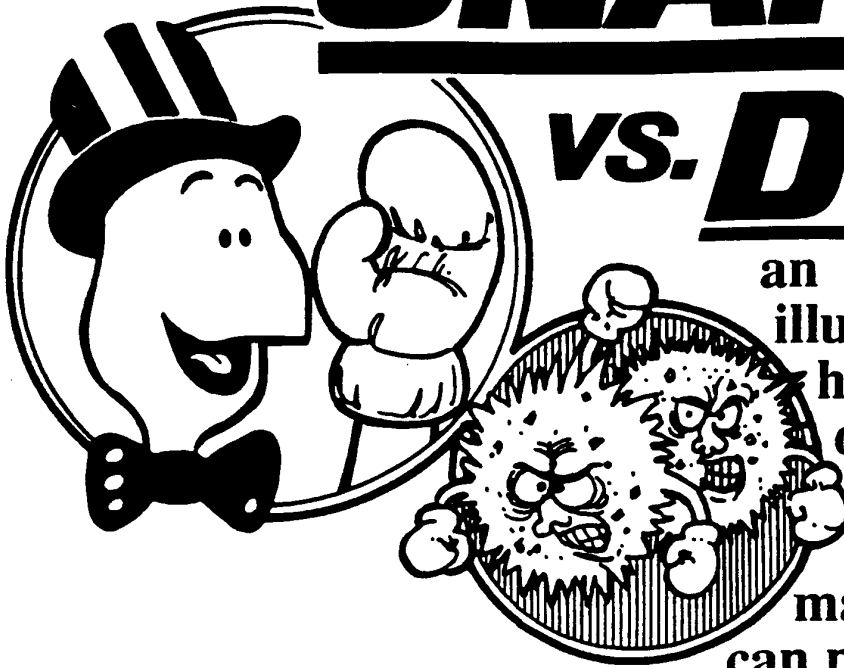

Snapper uses the best available engines and components in their products in order to provide long, satisfactory service. However, proper care is essential in prolonging engine life. Dirt is your engine's *enemy number 1!*

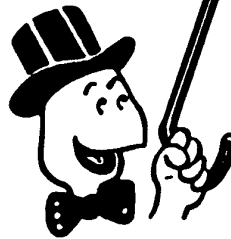
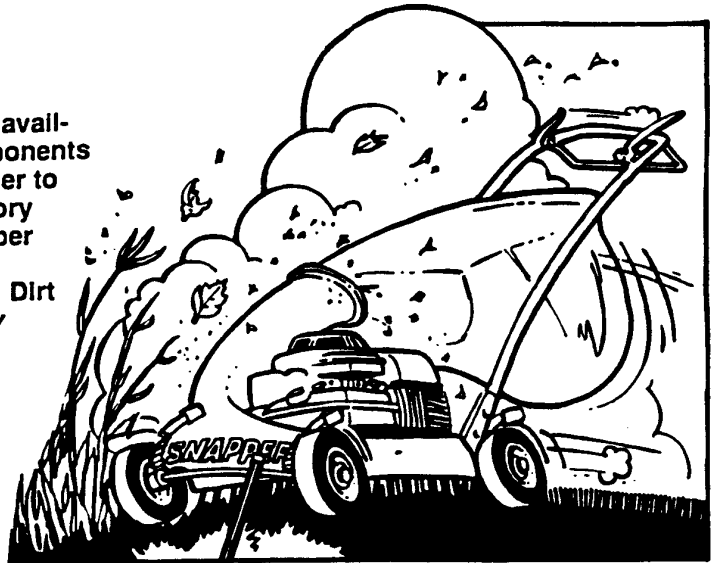

The engine on your Snapper product spends its entire life operating close to the ground at high speed creating a virtual storm of dust and dirt!

## PRIMARY MAINTENANCE

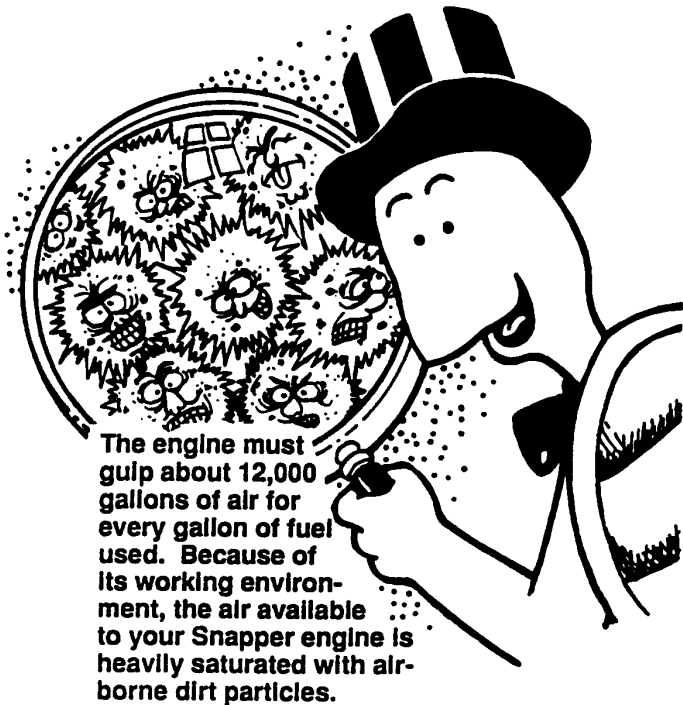

The engine must gulp about 12,000 gallons of air for every gallon of fuel used. Because of its working environment, the air available to your Snapper engine is heavily saturated with airborne dirt particles.

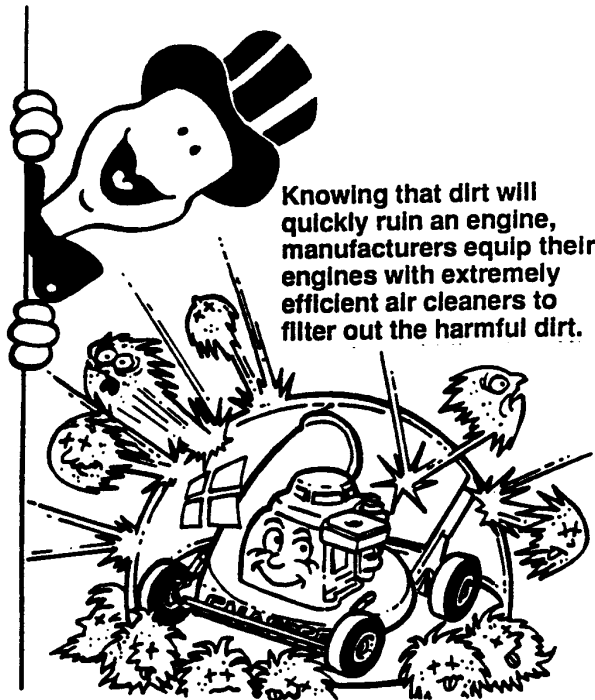

Knowing that dirt will quickly ruin an engine, manufacturers equip their engines with extremely efficient air cleaners to filter out the harmful dirt.

As the dirt particles are stopped, they build up and begin to clog the outside of the filter. This reduces the amount of air available to the engine and causes an over-rich fuel mixture which results in the following adverse effects:

An improperly serviced, dirt clogged air cleaner will:

1. Increase fuel consumption
2. cause power loss
3. result in hard starting
4. create smoke from unburned fuel
5. produce carbon build-up internally
6. foul spark plug electrodes
7. score cylinder walls
8. burn valves
9. wear out the engine prematurely
10. **COST YOU MONEY!**

Damage caused by a poorly serviced air cleaner is not covered under the engine warranties. So, save yourself unnecessary expenses and undue aggravation by keeping the air cleaner properly serviced at the intervals specified in the engine owner's manual.

It doesn't take long to service an air cleaner. Follow the specific instructions in the engine owner's manual for the type filter used. Prevent dirt from falling into the carburetor intake when servicing your air cleaner. Make sure components are installed in correct sequence after servicing to prevent unfiltered air from entering the engine. Some servicing hints on several common types are:

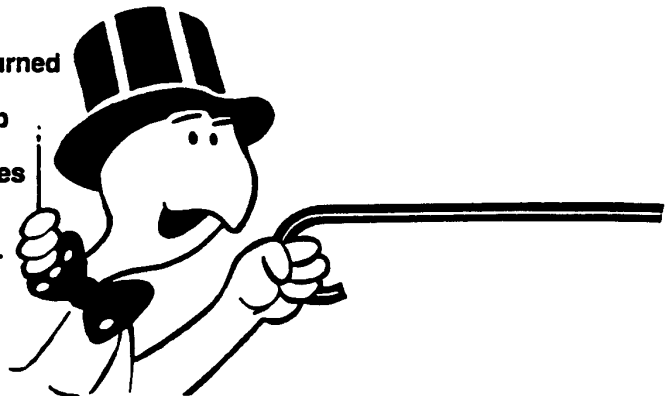
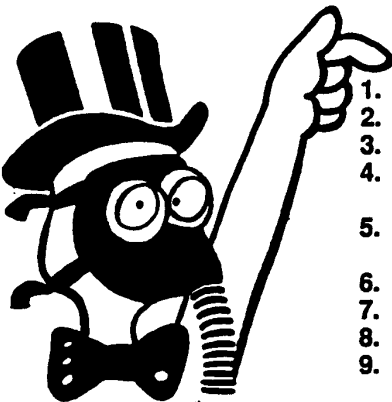

# PRIMARY MAINTENANCE

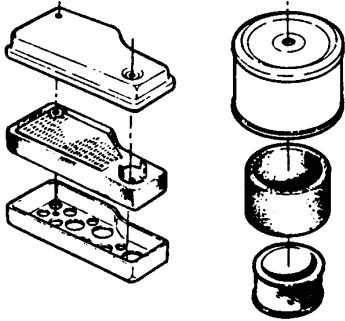

Generally, wash foam-type filters in a dishwashing detergent and water solution. Rinse and wring dry, then saturate with oil and squeeze out excess. *Failure to re-oil this type filter will ruin the engine.*

Clean paper elements by tapping lightly. Blowing with air will rupture paper elements.

Use a flashlight to detect clogged or torn paper elements - replace if damaged in any way.



Air is also needed to keep your engine cool. Dirt, dust & debris build up to restrict and clog cooling air intake screens and fins. Clean screens and fins at frequent intervals. The engine blower housing and shrouds should be removed at least once each season or more often under dry, dusty conditions for a thorough cleaning of fins.

Failure to keep external surfaces clean not only presents fire hazards, but causes overheating and resulting engine damages such as:

1. distorted valve guides
2. sticking valves
3. scuffed, scored cylinder walls
4. overspeeding
5. loss of power
6. complete failure of engine.

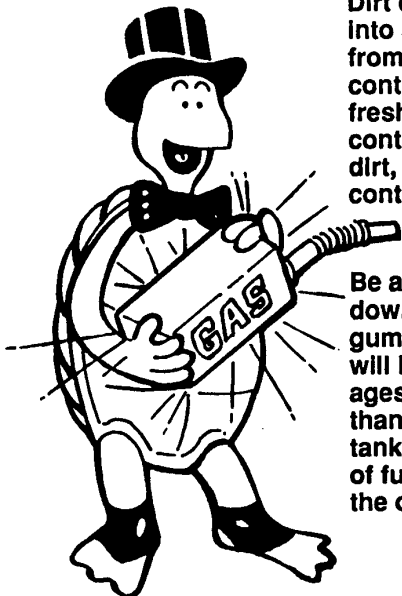
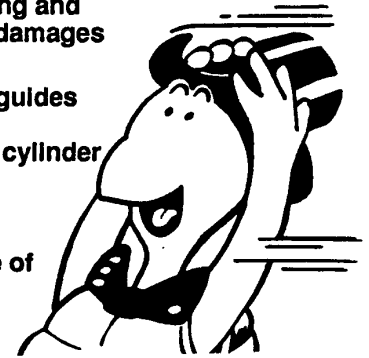

Dirt can also be introduced into an engine in dirty fuel from a contaminated container. Always use clean fresh fuel from a clean container to guard against dirt, sludge and water contamination.

Be aware that fuel breaks down in storage and forms gummy compounds which will block carburetor passages. Never use fuel more than 3 months old. Drain tank then run the engine out of fuel before storing during the off-season.

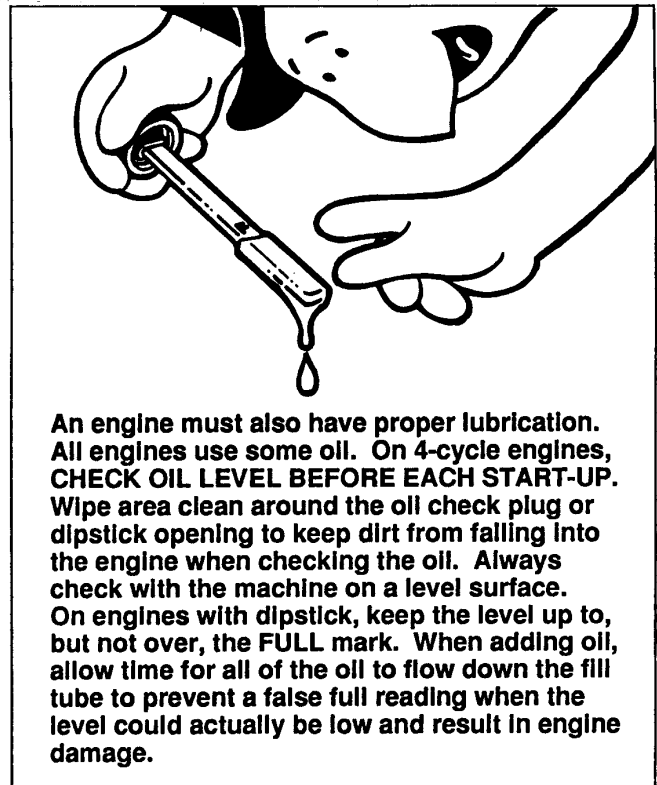

An engine must also have proper lubrication. All engines use some oil. On 4-cycle engines, **CHECK OIL LEVEL BEFORE EACH START-UP.** Wipe area clean around the oil check plug or dipstick opening to keep dirt from falling into the engine when checking the oil. Always check with the machine on a level surface. On engines with dipstick, keep the level up to, but not over, the **FULL** mark. When adding oil, allow time for all of the oil to flow down the fill tube to prevent a false reading when the level could actually be low and result in engine damage.

# PRIMARY MAINTENANCE

On 4-cycle engines with an oil level plug, don't be fooled into thinking the engine has sufficient lubricating oil if you can see "some" oil in the opening - the level should always be brought up to the point of overflowing at the top of the fill hole.

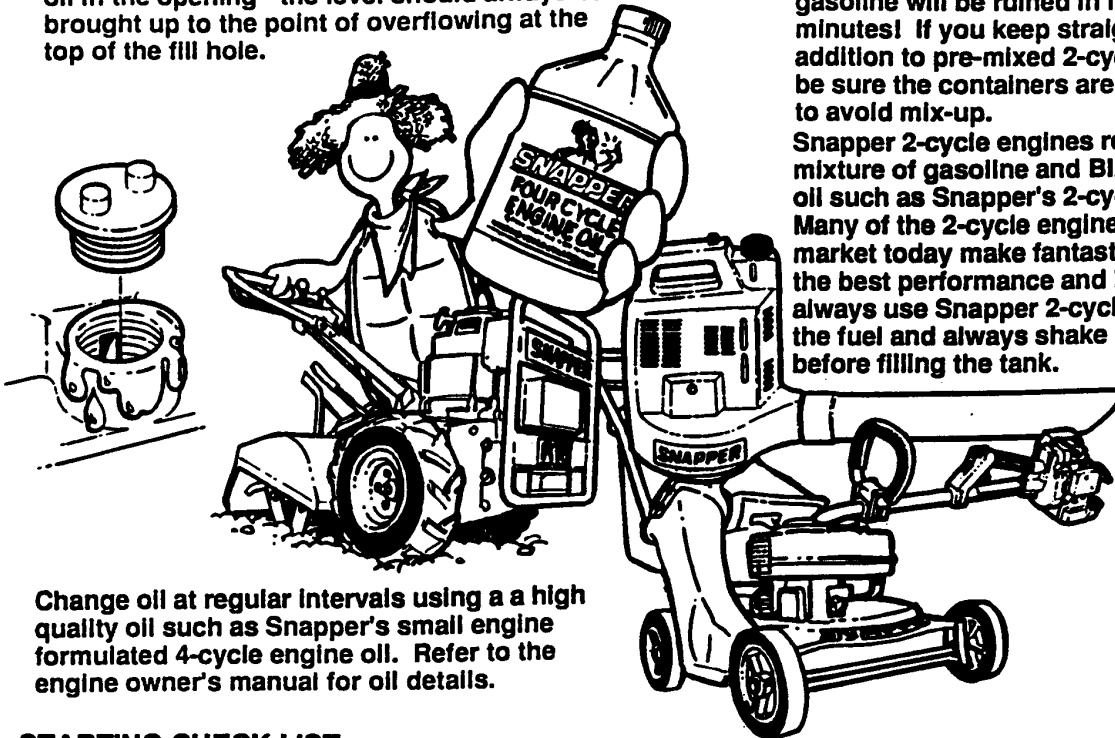

On 2-cycle engines, lubrication must be provided by an exact mixture of gasoline and 2-cycle air-cooled engine oil. A 2-cycle engine that is mistakenly run on straight gasoline will be ruined in less than 5 minutes! If you keep straight gasoline in addition to pre-mixed 2-cycle engine fuel, be sure the containers are clearly marked to avoid mix-up.

Snapper 2-cycle engines require a 32 to 1 mixture of gasoline and BIA certified TC-W oil such as Snapper's 2-cycle engine oil. Many of the 2-cycle engine oils on the market today make fantastic claims, but for the best performance and long engine life, always use Snapper 2-cycle oil. Pre-mix the fuel and always shake the container before filling the tank.

Change oil at regular intervals using a high quality oil such as Snapper's small engine formulated 4-cycle engine oil. Refer to the engine owner's manual for oil details.

## STARTING CHECK LIST

- |                              |  |
|------------------------------|--|
| 1. Engine Oil                | <ul style="list-style-type: none"> <li>• To full level (4-cycle)</li> <li>• Properly mixed with gas (2 cycle)</li> </ul>             |
| 2. Air Cleaner               | <ul style="list-style-type: none"> <li>• Clean and properly serviced</li> <li>• Full fresh clean gasoline</li> </ul>                 |
| 3. Fuel Tank                 | <ul style="list-style-type: none"> <li>• Fuel valve open</li> <li>• Cap vent open</li> <li>• Inline filter clean</li> </ul>          |
| 4. Choke                     | <ul style="list-style-type: none"> <li>• Operating properly</li> </ul>   |
| 5. Primer (on some engines)  | <ul style="list-style-type: none"> <li>• Used properly</li> </ul>  |
| 6. Safety Interlock Switches | <ul style="list-style-type: none"> <li>• In proper position</li> <li>• All wires properly connected</li> </ul>                       |
| 7. Switch & Blade Control    | <ul style="list-style-type: none"> <li>• Switch On</li> <li>• Blade control properly positioned on walk mower</li> </ul>             |
| 8. Spark plug                | <ul style="list-style-type: none"> <li>• Wire connected</li> <li>• Good connection</li> <li>• Start position</li> </ul>              |
| 9. Throttle control          |  |
| 10. Blade                    | <ul style="list-style-type: none"> <li>• Properly installed and torqued</li> <li>• Sharpened</li> </ul>                              |
| 11. Muffler                  | <ul style="list-style-type: none"> <li>• Good condition</li> <li>• Not clogged</li> <li>• Grass &amp; leaves cleaned away</li> </ul> |

Read and follow all safety instructions in safety booklets and manuals.

Keep in mind that dirt is your engine's *enemy* #1 both internally and externally! Internally, dirt will quickly ruin an engine and externally it will cause overheating and resulting internal damages. Damage caused by improper lubrication, poor air cleaner service or overheating due to dirt cannot be covered under warranty.

It only takes a few moments to service the engine (and equipment) on a routine basis but the rewards will be a quick starting, responsive engine that will provide long satisfactory service with minimum maintenance cost. The prestart checklist in the next column and instructions in your Snapper Operator's Manual are designated to help you keep your Snapper in top operating condition with minimum effort!





*Safety Instructions & Operator's Manual for*

# **SNAPPER**®

## **PRO HYDRO MID-SIZE WALK BEHIND MOWERS SERIES 1**

### **IMPORTANT**

Snapper products are built using engines that meet or exceed all applicable emissions requirements on the date manufactured. The labels on those engines contain very important emissions information and critical safety warnings. Read, Understand, and Follow all warnings and instructions in this manual, the engine manual, and on the machine, engine and attachments. If you have any questions about your Snapper product, contact your local authorized Snapper dealer or contact Snapper Customer Service at Snapper, McDonough, GA. 30253. Phone: (1-800-935-2967).

**⚠ WARNING:** The engine exhaust from this product contains chemicals known to the State of California to cause cancer, birth defects or other reproductive harm.

**SNAPPER**® McDonough, GA., 30253 U.S.A.

COPYRIGHT © 1999  
SNAPPER INC.  
ALL RIGHTS RESERVED

**MANUAL No. 7-3071 (I.R. 8/20/99)**