

MODEL 315W WINE COOLER

INSTALLATION & OPERATION





CONTENTS

Model 315W Features	4
Model 315W Installation	5
Installation Checklist	13
Model 315W Operation	14
Troubleshooting Guide	17
Service Information	18
Sub-Zero Warranty	19

Features and specifications indicated herein and on the website are subject to change at any time without notice. Check our website, subzero.com, for the most up-to-date specifications.

As you follow these instructions, you will notice **WARNING** and **CAUTION** symbols. This blocked information is important for the safe and efficient installation of Sub-Zero equipment. There are two types of potential hazards that may occur during installation.

⚠ CAUTION

signals a situation where minor injury or product damage may occur if you do not follow instructions.

⚠ WARNING

states a hazard that may cause serious injury or death if precautions are not followed.

Another footnote we would like to identify is **IMPORTANT NOTE**: This highlights information that is especially relevant to a problem-free installation.



THANK YOU

Congratulations on the purchase of your Sub-Zero Model 315W wine cooler. This unit is designed and manufactured in the Sub-Zero tradition of superior quality and reliability.

The importance of the installation of the Model 315W wine cooler cannot be overemphasized. Installation should be done by a qualified installer.

Before you begin the installation process, it is recommended that you read the entire installation instructions. There are key details that you should take special care to observe during the installation. By reading these instructions carefully, you will make the installation process easier, problem-free and, most importantly, safe.

Any questions or problems about the installation should be directed to your Sub-Zero dealer or the Sub-Zero Customer Service Department at 800-222-7820. You can also visit our website at subzero.com.

The Model 315W wine cooler is protected by a warranty that is one of the finest in the industry. Take a moment to read the warranty statement on page 19 and refer to it should service become necessary.

The Operation information in this book will answer most of your questions about the features, operation and maintenance of your wine cooler. If you have questions that are not addressed here, call Sub-Zero Customer Service at 800-222-7820 or visit our website, subzero.com.

CONTACT INFORMATION

**Sub-Zero
Customer Service:
800-222-7820**

**Website:
subzero.com**



MODEL 315W FEATURES

- Undercounter wine cooler with 26 (750 ml) bottle capacity
- Overlay and stainless steel design options
- Ideal humidity and temperature range of 45°F (7°C) to 55°F (13°C).
- Sturdy, rustproof wire shelves accommodate standard 750 ml bottles, half-bottles, as well as magnums
- Roller-glide shelves faced with natural cherry wood have a three-quarter extension for easy access
- Full-view glass door with UV resistant glass protection
- High altitude glass door
- Discreet low voltage interior lighting
- UL approved for US and Canada
- Two, five and twelve year residential warranty – exclusions apply, see warranty at the end of this guide

WARRANTY

Sub-Zero products are covered by a two, five and twelve year residential warranty (exclusions apply). See warranty details at the end of this guide.

MODEL 315W

Wine cooler

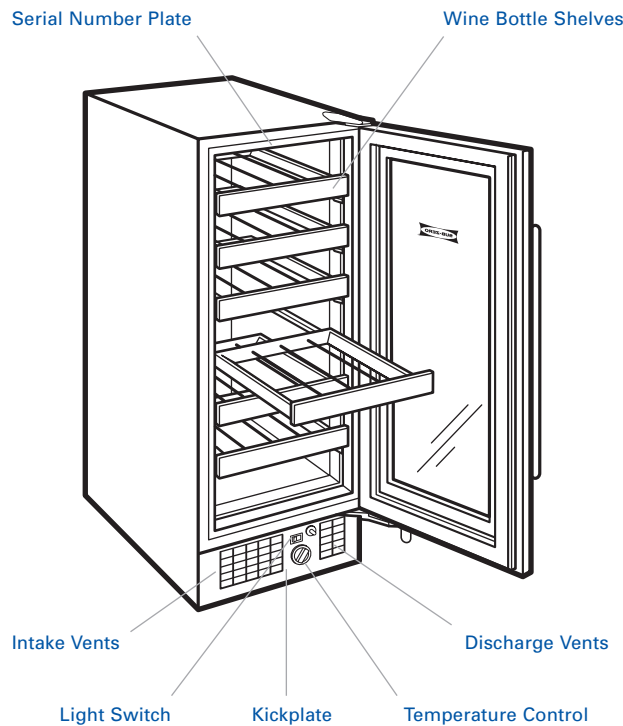



INSTALLATION SPECIFICATIONS

MODEL 315W DIMENSIONS

Overall Width	15 1/8" (384)
Overall Height	34 1/16" (865)
Overall Depth – 315W/S	23 5/32" (588)
Overall Depth – 315W/O	22 3/8" (568)
Rough Opening Width	15 1/4" (387)
Rough Opening Height	34 1/2" (876)
Minimum Height Required (levelers in)	34 1/16" (865)
Rough Opening Depth	24" (610)

Dimensions may vary ± 1/8" (3).

OVERALL DIMENSIONS

Stainless steel unit shown

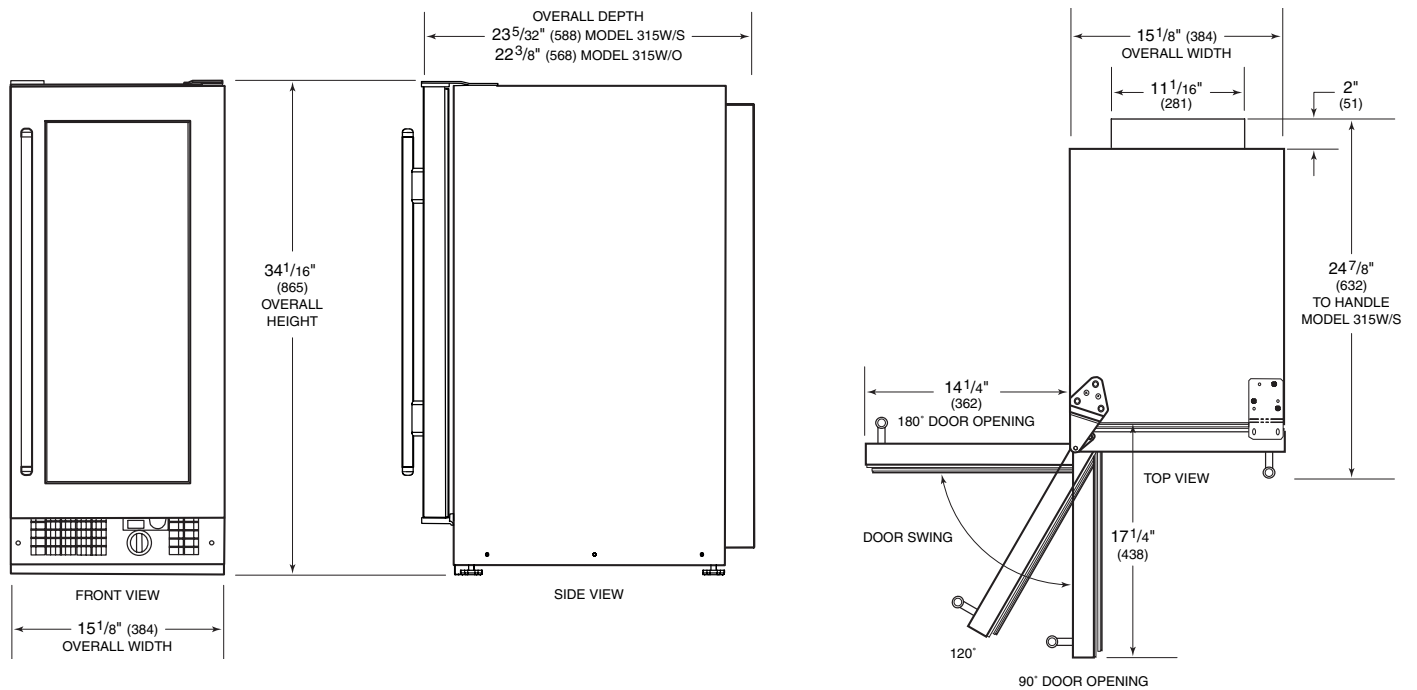

Dimensions may vary ± 1/8" (3).

NOTE: Door swing not reversible.

Dimensions in parentheses are in millimeters unless otherwise specified.



INSTALLATION SPECIFICATIONS

AREA REQUIREMENTS

Before moving the unit into place, be sure that the rough opening dimensions, electrical location, and minimum door clearances are accurate. Refer to the illustration below. Also Refer to page 5 for overall dimensions.

Be sure your electrician and cabinet installer have this information before finishing work is completed.

IMPORTANT NOTE: Make sure the floor under the unit is level with the surrounding finished floor.

IMPORTANT NOTE: For corner installations, door swing may be limited due to handle contact with the adjacent wall or cabinet face. You must allow a minimum of 2" (51) from the wall for a 90° door opening. This will ensure that the wine shelves can be fully extended.

⚠ CAUTION

Wine bottles are heavy. A fully loaded unit will weigh over 200 lbs (91 kg). Be sure the subflooring is adequate for the weight of both the unit and its contents.

⚠ WARNING

The Model 315W is intended for indoor use only.

ROUGH OPENING DIMENSIONS

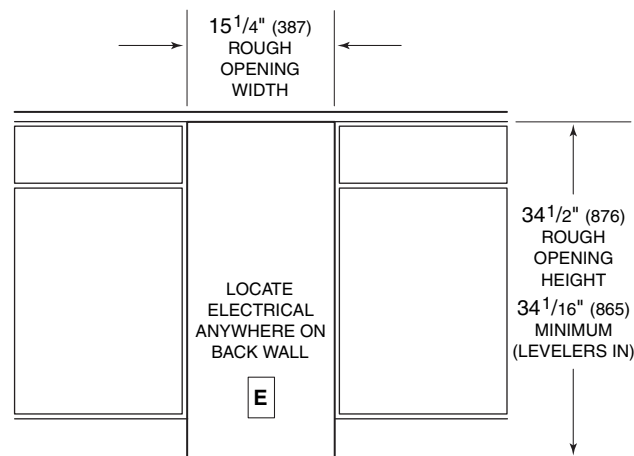

FRONT VIEW

NOTE: ROUGH OPENING DEPTH IS 24" (610)

Dimensions in parentheses are in millimeters unless otherwise specified.



ELECTRICAL REQUIREMENTS

A 115 V AC, 60 Hz, 15 amp circuit breaker and electrical supply are required. A separate circuit is required for each unit.

The Model 315W is equipped with a power supply cord with a 3-prong grounding plug, which must be plugged into a mating 3-prong grounding-type wall receptacle. Refer to the illustration below. Follow the National Electrical Code and local codes and ordinances when installing the receptacle. For location of the electrical supply, refer to the Rough Opening Dimensions illustration on page 6.

IMPORTANT NOTE: A ground fault circuit interrupter (GFCI) is not recommended and may cause interruption of operation.

⚠ WARNING

Do not use an extension cord or two-prong adapter. Electrical ground is required on this appliance. Do not remove the power supply cord ground prong.

KICKPLATE AIRFLOW

The wine cooler uses a fan to take in room air through vents in the left side of the kickplate, and discharges warm air through vents in the right side. These vents must be kept clear of obstructions or decorative panels. Blocking or obstructing the kickplate will restrict air flow and cause a decrease in performance and efficiency. Refer to the illustration below.

IMPORTANT NOTE: The minimum air temperature the wine cooler will operate in is 50°F (10°C), and the maximum is 100°F (38°C).

MOVING THE UNIT

IMPORTANT NOTE: When you move the unit using a hand truck or dolly, position the dolly on the side of the unit and secure the door so it does not open while transporting.

IMPORTANT NOTE: When moving and installing the Model 315W/S, be sure to protect all stainless steel surfaces from scratches.

Once the unit is in place, remove any tape or other packaging material from the inside. Check that all wine shelves fully extend.

⚠ CAUTION

Any finished flooring should be protected with appropriate material to avoid any damage from moving the unit.

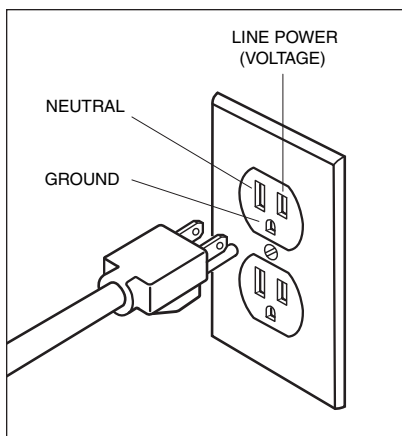

Grounded electrical outlet

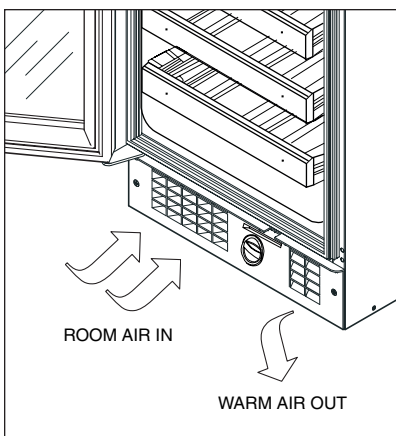

Kickplate airflow



BLOCKING FOR SAFETY

⚠ WARNING

To prevent the unit from tipping forward if multiple loaded bottle racks are pulled out at one time, and to provide a stable installation, the unit must be secured in place with an anti-tip device.

A metal anti-tip bracket and screws are provided with the unit. Attach the anti-tip bracket to the top of the unit, opposite the hinge side. The bracket offset flange should be facing up with the two oblong holes also in the front. Once the unit is moved into position, open the door and secure the anti-tip bracket to the countertop. Refer to illustration below.

LEVELING THE UNIT

⚠ WARNING

Shut off the power to the electrical outlet.

IMPORTANT NOTE: The unit must be leveled prior to placing it in the rough opening.

There are four leveling legs on the Model 315W, one at each corner. To assist you in adjusting the front leveling legs up or down, tip the unit back slightly to allow access to leveling legs. Use a pliers and place around the leveling leg, or use a screwdriver and turn the front leg to make necessary adjustments.

To level the unit, turn the leveling legs counter-clockwise to raise the unit, or clockwise to lower it. Refer to the illustration below.

To assist you in proper leveling, we recommend using a 2' (.6 m) level. There are two recommended level locations: along the top of the unit or on either exterior side of the unit. These positions will help determine the vertical and horizontal level point. In order to access these leveling positions, the unit will have to be slightly out of the opening.

Place the unit in the rough opening. Make sure the power cord is plugged in before positioning the unit. Turn the power back on to the electrical outlet.

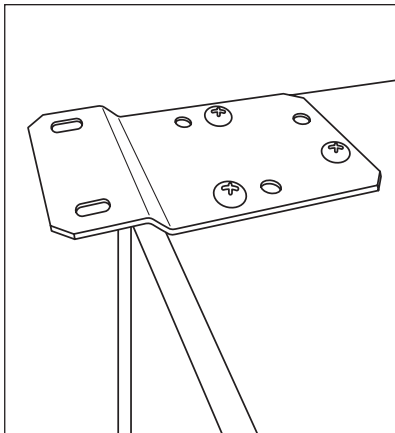

Anti-tip bracket

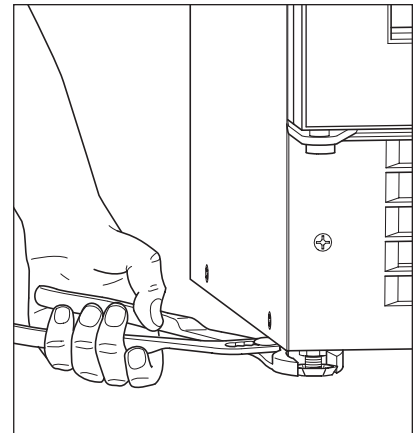

Adjusting leveling legs

Dimensions in parentheses are in millimeters unless otherwise specified.



KICKPLATE INSTALLATION

Once the Model 315W is in place, you can install the kickplate. There is some adjustment to the mounting assembly so that the kickplate will fit flush with the surrounding area. Be sure that nothing obstructs the vents of the kickplate. Refer to the illustration below.

The kickplate can be painted another color, if you choose. Follow these easy steps:

- Rough up surface to be painted with fine grit sandpaper
- Wipe with alcohol to ensure it is clean and dry
- Use an appliance or industrial grade oil base, or high gloss enamel paint

⚠ CAUTION

DO NOT cover the kickplate area.

IMPORTANT NOTE: The Model 315W has been designed to be serviced in place, but in some cases it may be necessary to pull the unit out for service. For this reason, do not restrict access to the cabinet at the front top and bottom.

If a floor is to be installed after the unit has been installed, spacing shims equal to the thickness of the floor should be installed under the unit to keep it level with the floor.

PANEL CONSIDERATIONS

The Model 315W offers two door panel design alternatives; stainless steel (/S) or overlay (/O). Both of these design options are available with glass (G) doors.

Model 315W/S (classic stainless steel) is shipped from the factory with the decorative stainless steel door panel and matching handle in place.

The Model 315W/O (overlay) door is designed to accept a decorative door panel to match surrounding cabinetry. The door panel and the handle will be provided by the customer.

For overlay panel handle hardware, we recommend a D-style handle, centered top to bottom along the edge opposite the hinge. You may have to countersink screw heads to ensure hardware does not interfere with panels fitting flush with unit doors.

Before beginning installation, check for the correct components for the fit and finish desired.

If you have questions, contact your Sub-Zero dealer or cabinet supplier. Additional panel information can be found in the Sub-Zero Design Guide. Check our website at subzero.com.

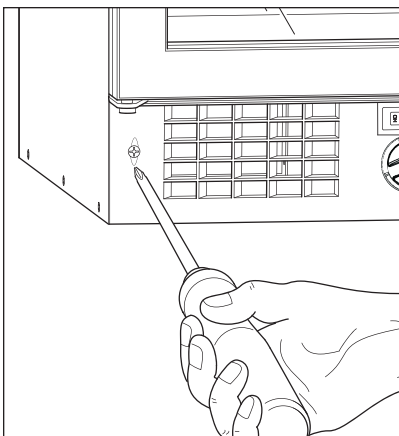

Kickplate installation



OVERLAY PANELS

OVERLAY PANEL SPECIFICATIONS

Door Panel Width – 1/8" (3) reveal*	15" (381)
Door Panel Height – 7/16" (11) reveal** 4" (102) toe space	30 1/16" (764)
Width of Rails and Stiles	2 1/4" (57) min
Door Panel Thickness	5/8" (16) min
Door Panel Weight	10 lbs (4.5 kg) max

Dimensions may vary ± 1/8" (3).

**1/8" reveal is required if two units are placed side by side.*

***7/16" (11) reveal from top of door panel to top of hinge.*

Inspect the door panel for the minimum 5/8" (16) thickness, the finished inside edge and the 10 lbs (5 kg) weight limit. See the Wine Storage section of the Sub-Zero Design Guide for additional panel information. Check our website at subzero.com.

Decide if the handle will be attached through the glass door frame or just through the decorative door panel. If it is just through the door panel, the handle must be attached first.

If you choose not to use the pre-drilled handle mounting holes, it will be necessary to fasten the handle from the rear of the door panel only, or drill one or more additional holes through the metal frame of the glass door.

PANEL DESIGN

Additional panel design information can be found in the Sub-Zero Design Guide. Check our website at subzero.com.

⚠ CAUTION

A solid panel must not be installed on a glass door unit, as this may cause moisture to form behind the panel.

OVERLAY DOOR DIMENSIONS

Overlay unit shown

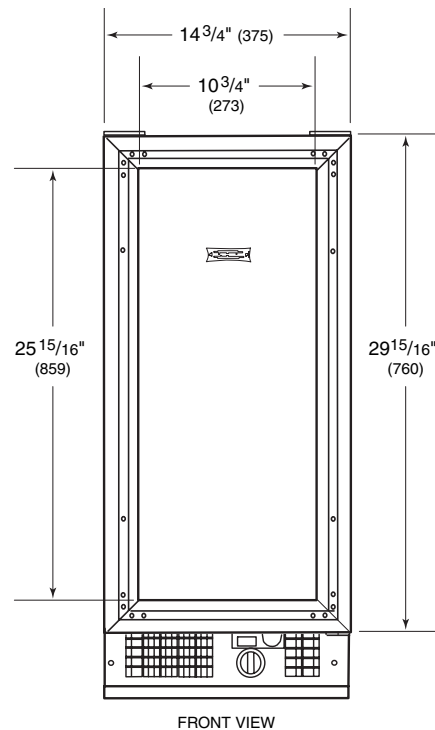

Dimensions in parentheses are in millimeters unless otherwise specified.



OVERLAY PANEL INSTALLATION

A decorative panel is attached to the Model 315W door using #8 x $\frac{5}{8}$ " (16) square drive screws passing through the door frame from the rear, behind the gasket into the panel. The door panel is marked for screw locations by the use of 'tenon centers', which are temporarily inserted into the $\frac{1}{4}$ " (6) diameter holes in the front of the glass door frame. Refer to the illustration below.

With the unit secured in position and the door closed, the panel is held in the desired position on the door and rapped by hand from the front, putting center marks on the rear surface of the panel. If the door panel is made of such a material that pre-drilling is needed, all of the mounting holes should be marked. If not, only enough holes to hold the panel in place temporarily are necessary.

The door panel is then removed from the door frame, tenon centers removed, the door opened and the screws driven into the panel through the black tape on the door frame, using the center marks to locate the screws.

The screw holes inside the door, are hidden under a cover flap on the door gasket. It is necessary to lift the flap to insert the screws. Use as many screws as necessary to hold door panel in place properly.

IMPORTANT NOTE: After the first three or four mounting screws are in place, but not completely tightened, close the door and check your panel fit. This is the time to make small adjustments. Once you are satisfied with the appearance, open the door and apply the remainder of the screws. Check all screws for tightness.

The metal frame on the glass door has numerous mounting holes on each side of the door. This is to accommodate the Sub-Zero accessory handles and provide for easy attachment of the handle through the door frame.

The illustration below shows how the holes pass through the door frame. The hole center is on the small locator groove in the front of the frame. A $\frac{1}{4}$ " (6) diameter hole is made in the front wall of the extrusion and a $\frac{13}{32}$ " (11) diameter hole through the rest of the frame.

⚠ CAUTION

Exercise caution when drilling holes for mounting the panel to the door frame.

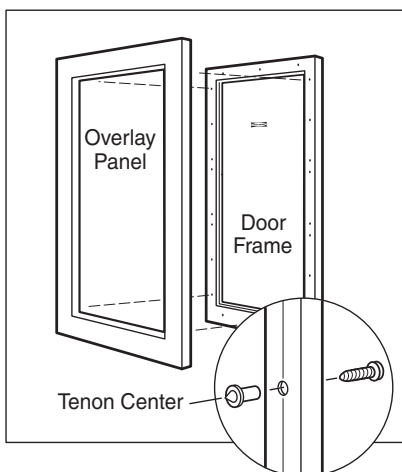

Overlay door panel

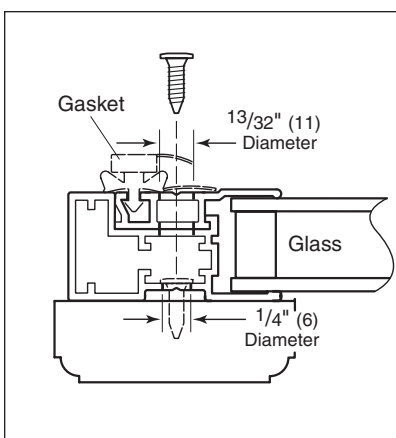

Door frame cross-section



OVERLAY PANEL INSTALLATION

IMPORTANT NOTE: Install screws in all the mounting holes in the door frame. The nature of the door panel with a narrow outer rim and no connecting center member requires the support provided by the glass door.

After the door panel installation is complete, apply the cover patches or plugs provided over the holes on the inside surface of the door.

PANEL DESIGN

Additional panel design information can be found in the Sub-Zero Design Guide. Check our website at subzero.com.

⚠ CAUTION

The wine cooler door is made with a sealed double wall tempered glass core. The drill must not contact this core when drilling. Be sure the hole is centered on the small groove in the front of the door frame and the drill passes squarely through the frame. If you are inexperienced with drilling, fasten the handle from the rear of the door panel only.

⚠ CAUTION

The cover patches or plugs are part of the insulation system on the door of the wine cooler. Be sure to cover all the holes in the door that were used.



INSTALLATION CHECKLIST

IMPORTANT NOTE: To ensure a safe and proper installation, the following checklist should be completed by the installer to ensure that no part of the installation has been overlooked.

Any questions or problems about the installation should be directed to your Sub-Zero dealer or the Sub-Zero Customer Service Department at 800-222-7820. You can also visit our website at subzero.com.

- Is the unit operating? If not, is the unit plugged in? Check to see if the unit is operating before you install.
- Has the unit been properly uncrated, and have all packing materials and tape been removed from inside the product?
- Have the installation instructions been followed?
- Has the unit been leveled?
- Is the kickplate installed?
- If applicable, is the door panel installed properly?
- Does the customer understand the unit's operation?
- Have any installation or service problems been noted on the product registration card? Instruct the owner to register the product.

⚠ WARNING

If you are storing or disposing of your old refrigerator or freezer, please do it safely. Remove the doors or tightly secure the doors closed. Child entrapment accidents can be tragic.

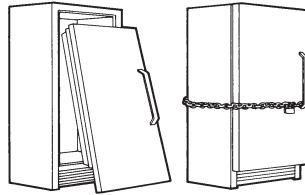

CONTACT INFORMATION

**Sub-Zero
Customer Service:
800-222-7820**

**Website:
subzero.com**



USING YOUR WINE COOLER

Your wine cooler is extremely simple to use, just turn the control knob to the ON position. The Model 315W will automatically begin to cool and will continue to do so until the set temperature is reached.

The Model 315W operates on this principal; the unit will run to achieve the set temperature. Run time will vary based upon the amount of usage, room temperature and amount of wine added.

SETTING THE TEMPERATURE

Rotate the temperature adjustment knob until the desired temperature is achieved. Turn the knob clockwise to make the unit colder. Refer to the illustration below. Interior cabinet temperatures may be a slightly warmer at the top or front of unit and cooler at the bottom and back.

IMPORTANT NOTE: The wine cooler will not cool down immediately upon initial start-up. Allow approximately 24 hours for unit to reach desired temperature.

When fully loaded with room temperature wine, the Model 315W will operate continuously for as long as 24 hours to reach the desired temperature. After reaching the set temperature, the unit will begin to cycle on and off.

IMPORTANT NOTE: A unit fully loaded with wine will run less than a unit which is partially full.

LIGHT SWITCH

The display light automatically switches on when the door is opened. To have the light on when the door is closed, move the light switch to the ON position. Refer to the illustration below.

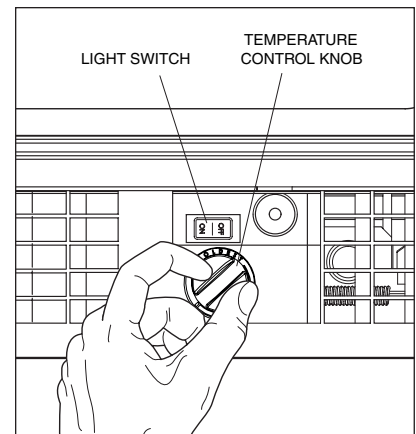

Temperature control and light switch



WINE SHELVES

Model 315W has roller-assembly shelves with a full three-quarter extension for easy access to wine bottles. Each wine shelf holds four (750 ml) bottles. An additional two (750 ml) bottles may be placed on the bottom stationary shelf for a total capacity of 26 bottles. Refer to the illustration below.

IMPORTANT NOTE: Never keep anything other than wine bottles on the wine shelves; smaller beverage bottles are unstable and may easily fall out and break.

The shelves have a solid natural cherry wood facing that can be replaced with other wood to match your cabinetry. Details on how to replace the shelves' wood facing can be found in the Sub-Zero Design Guide. Check our website at subzero.com.

IMPORTANT NOTE: If you choose to stain or seal the shelves' natural cherry wood facing, be aware that some of these substances are hazardous and will damage wine.

⚠ CAUTION

Be sure to unload all bottles from the wine shelf before removing it.

WINE SHELF REMOVAL

To remove a wine shelf, pull the shelf out to its full extension, gently and evenly lift up on both sides of the front of the shelf and remove. Reverse the procedure to reinstall the shelf.

IMPORTANT NOTE: Wine shelf removal will be more difficult if the door cannot open to a minimum of 120°, as in a corner application.

LIGHT BULB REPLACEMENT

The light bulb located in the top of the cabinet will last for a long time, however when it does fail or burn out, it can be replaced. Replacement bulbs (part #12288801) are available from your Sub-Zero authorized service center.

To replace the light bulb, unplug the unit. Remove the top wine shelf. Pull the plug from the socket in the top of the unit as shown in the illustration below. Remove the bulb from its holder and install the new bulb.

⚠ WARNING

Shut off power to the unit before replacing light bulbs. Wear protective gloves when handling bulbs.

DESIGN GUIDE

Details on how to replace the wine shelves' cherry wood facing can be found in the Sub-Zero Design Guide. Check our website at subzero.com.

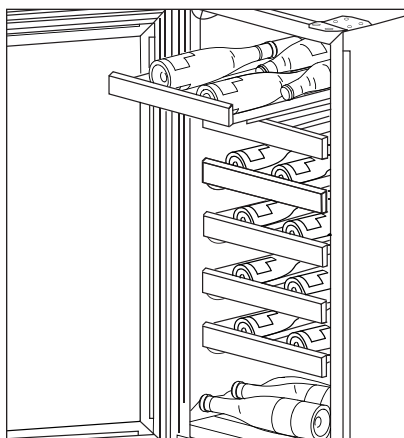

Wine shelves

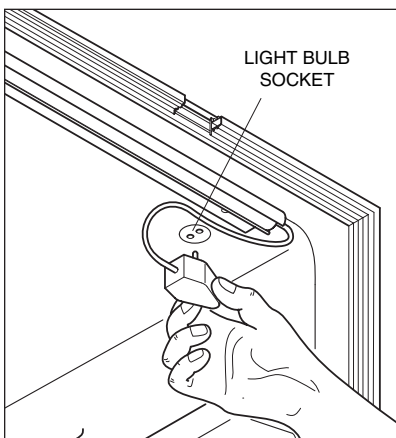

Light bulb replacement



CLEANING

SIGNATURE POLISH

Signature Polish is available from Signature Limited Laboratory, P. O. Box 13436, Dayton, Ohio 45413-0436, or call 877-376-5474 (toll free).

EXTERIOR CLEANING

To clean the classic stainless steel exterior of the Model 315W/S, use a soft, nonabrasive stainless steel cleaner like Signature Polish (see side note) and apply with a soft 100% lint-free cloth.

If anything spills onto the door gasket, wash with soap and warm water to remove. Rinse and dry thoroughly.

GLASS DOOR CLEANING

The glass door panel can be cleaned using any standard glass cleaner available on the market today.

INTERIOR CLEANING

To clean interior surfaces and removable parts, wash with a mild solution of soap and luke-warm water with a little baking soda. Do not use vinegar. Rinse and dry thoroughly. Avoid getting water on lights, control panel and the solid cherry wood facing on the shelves.

Do not use abrasive cleaners or cloths on any of the interior or exterior surfaces, including the glass door panel.

CLEANING THE CONDENSER

⚠ WARNING

Before cleaning the condenser and other routine maintenance, shut off power at the circuit breaker supplying power to the electrical outlet.

The air-cooled condenser should be vacuumed two to three times per year to remove any lint that may have been drawn into the condenser. To access the condenser, use a phillips head screw driver to remove the kickplate as shown in the illustration below. Then using a soft bristle brush, vacuum to remove dust and lint from the condenser. Refer to the illustration below.

IMPORTANT NOTE: To avoid bending the condenser fins, be sure to vacuum in the direction of the fins (up and down).

⚠ CAUTION

Failure to clean the condenser could result in temperature loss or mechanical failure or damage.

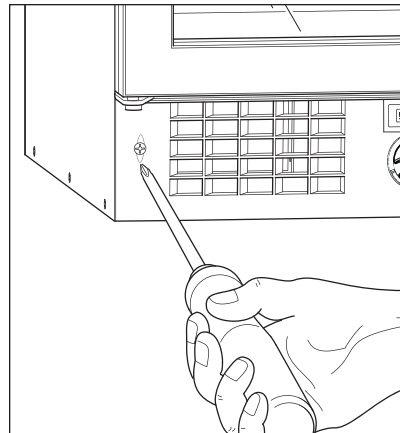

Kickplate removal

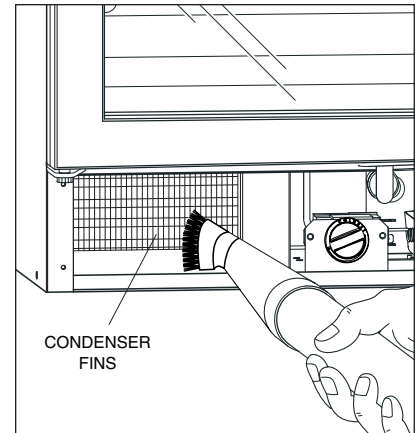

Cleaning the condenser



TROUBLESHOOTING GUIDE

PROBLEM	POSSIBLE CAUSE	POSSIBLE SOLUTION
Cabinet too warm	Unit switched off	Check temperature control
Cabinet temperature changed	Temperature control setting changed	Check temperature setting
Excessive operating time	Dirty condenser	Clean condenser
	Cabinet full of warm wine	Unit must operate for up to 24 hours to cool warm wine
	Door gasket not sealing tightly	Check gasket fit
	Thick frost on evaporator (see below)	Shut unit off until frost melts, (see below)
	Unit in warm room conditions	Sunlight or high room temperatures will increase operating time
Excessive noise	Fan will make some noise	May be normal
Unit will not cool	Fan blade contacting fan shroud	Check for free fan blade rotation
	Dirty condenser	Clean condenser
	Fan motor not turning blade	Contact authorized service center
	Low on refrigerant	Contact authorized service center
	Compressor not operating	Contact authorized service center
Thick frost on evaporator	Door gasket not sealing tightly	Check gasket fit
	Door not closing	Check door for obstructions
	Thermostat not keeping unit off long enough	Contact authorized service center
	Excessive operating time	Check for cause (see above)
Cabinet light does not work properly	Light bulb burned out	Replace light bulb (see page 15)
	Door switch does not close	Check door switch
	Cannot switch light on with door closed	Check rocker switch
Water running inside unit	Drain trough hose plugged	Contact authorized service center
Water leaking under unit	Drain hose out of position	Contact authorized service center
	Drain pan over filling	Check door or door gasket

SERVICE CENTER

Contact your Sub-Zero dealer or check the Locator section of our website, subzero.com, for the authorized service center nearest you.



SERVICE INFORMATION

SERVICE INFORMATION

If you do need service, be sure to have the model and serial number of your unit when you call. You'll find these numbers on the model and serial number plate located on the underside of the top wall. For warranty purposes, you will also need the date of installation and the name of your Sub-Zero dealer. Record this information below for future reference.

Model Number _____

Serial Number _____

Installation Date _____

Sub-Zero Authorized Service Center and Phone

Sub-Zero Dealer and Phone

BEFORE CALLING FOR SERVICE

Before calling a Sub-Zero authorized service center, refer to the Troubleshooting Guide on page 17. Check the household fuse or circuit breaker to see if it has been blown or tripped and that the electrical connection to the appliance has not been disconnected. A power outage may also have caused a disruption in service.

PRODUCT REGISTRATION

Register your new Sub-Zero today so that we may ensure your satisfaction. You may register by one of the following options:

- 1) Mail in the completed Sub-Zero Product Registration Card.
- 2) Register online at **subzero.com**.
- 3) Register by phone by calling the Sub-Zero Customer Service Department at **800-222-7820**.

The model and serial numbers of your unit are printed on the enclosed Sub-Zero Product Registration Card. Your registration information will allow us to send you exciting new product updates and recipes as they become available, along with information on special events.

The information and images in this guide are the copyright property of Sub-Zero Freezer Company, Inc. Neither this book nor any information or images contained herein may be copied or used in whole or in part without the express written permission of Sub-Zero Freezer Company, Inc.

©Sub-Zero Freezer Company, Inc. all rights reserved.

CONTACT INFORMATION

**Sub-Zero
Customer Service:
800-222-7820**

**Website:
subzero.com**

SUB-ZERO FREEZER COMPANY PRODUCTS LIMITED WARRANTY

RESIDENTIAL USE ONLY

FULL FIVE YEAR SEALED SYSTEM WARRANTY LIMITED SIXTH THROUGH TWELFTH YEAR WARRANTY ON THE SEALED SYSTEM FULL TWO YEAR WARRANTY ON TOTAL PRODUCT*

FULL FIVE YEAR SEALED SYSTEM WARRANTY

For five years from the date of original installation, your Sub-Zero warranty covers all parts and labor to repair or replace any components that prove to be defective in materials or workmanship in the sealed system. The sealed system consists of the compressor, condenser, evaporator, drier and all connecting tubing.

FULL TWO YEAR WARRANTY*

For two years from the date of original installation, your Sub-Zero warranty covers all parts and labor to repair or replace any part of the product, that proves to be defective in materials or workmanship.

LIMITED SIXTH THROUGH TWELFTH YEAR SEALED SYSTEM WARRANTY

From the 6th through the 12th year from the date of original installation, your Sub-Zero warranty covers all parts that prove to be defective in materials or workmanship in the sealed system (parts only). The sealed system consists of the compressor, condenser, evaporator, drier and all connecting tubing.

TERMS APPLICABLE TO EACH WARRANTY

All service provided by Sub-Zero under the above warranty must be performed by an authorized Sub-Zero service center, unless otherwise specified by Sub-Zero. Service will be provided in the home during the normal business hours. This warranty applies only to products installed for normal residential use. Details regarding a non-residential warranty are available upon request.

The warranty applies only to products installed in any one of the fifty states of the United States, the District of Columbia or the ten provinces of Canada. This warranty does not cover any parts or labor to correct any defect caused by negligence, accident or improper use, maintenance, installation, service or repair, including but not limited to improper removal and reinstallation (whether in the unit or at a remote location) of the condensing unit.

THE REMEDIES DESCRIBED ABOVE FOR EACH WARRANTY ARE THE ONLY ONES THAT SUB-ZERO WILL PROVIDE, EITHER UNDER THESE WARRANTIES OR UNDER ANY WARRANTY ARISING BY OPERATION OF LAW. SUB-ZERO WILL NOT BE RESPONSIBLE FOR ANY CONSEQUENTIAL OR INCIDENTAL DAMAGES ARISING FROM THE BREACH OF THESE WARRANTIES OR ANY OTHER WARRANTIES, WHETHER EXPRESS, IMPLIED OR STATUTORY.

Some states do not allow the exclusion or limitation of incidental or consequential damages, so the above limitation or exclusion may not apply to you. This warranty gives you specific legal rights and you may also have other legal rights, which vary from state to state.

To receive parts and/or service and the name of the Sub-Zero authorized service center nearest you, contact your Sub-Zero dealer, distributor or Sub-Zero Freezer Company, Customer Service Department, P.O. Box 44130, Madison Wisconsin, 53744-4130; check the Locator section of our website, subzero.com, or call 800-222-7820.

* Stainless Steel (classic, platinum and carbon) doors, panels, product frames and stainless interior surfaces are covered by a limited 60 day parts and labor warranty for cosmetic defects.

* Replacement water filter cartridges are not covered by the product warranty.



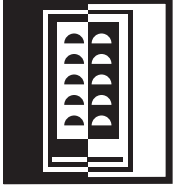

SUB-ZERO FREEZER COMPANY, INC. P. O. BOX 44130 MADISON, WI 53744-4130 800-222-7820 SUBZERO.COM

