

*Parts Manual for*

# **SNAPPER®**

## **21" STEEL DECK WALK BEHIND MOWERS SERIES 19**



### **MODEL**

2167519B (7800031)  
2167519B (7800174)  
2167519B (7800217)  
N2167519B (7800133)  
NP2167519B (7800134)  
NP2187519BV (7800131)  
P216019KWV (7800034)  
P216019KWV (7800193)  
P2167519B (7800032)  
P2167519B (7800175)  
P2167519B (7800218)  
P217019BV (7800033)  
P217019BVE (7800035)  
P2187519BV (7800176)  
P2187519BVE (7800178)  
RP216019KWV (7800029)  
RP216019KWV (7800199)  
RP2167519B (7800027)  
RP2167519BDV (7800066)  
RP217019BV (7800028)  
RP217019BVE (7800030)  
RP2187519BV (7800172)  
RP2187519BVE (7800173)

**Briggs & Stratton Yard Power Products Group**

535 Macon Road  
McDonough, GA, 30253 U.S.A.  
800-935-2967

**Revision B, 7/8/2008**

**Manual No. 7006149**

**TP 400-5187-B-WB-N**



<b>PAGE</b>	<b>GROUP</b>
4	HANDLES & CONTROLS
8	CUTTING DECKS, BLADES
10	WHEEL BRACKETS, LATCHES (Push)
12	WHEEL BRACKETS, LATCHES (Self-Propelled)
14	WHEELS, FRONT & REAR
16	DRIVE SYSTEM SELF-PROPELLED
20	TRANSMISSION (DIFFERENTIAL)
22	SIDE CHUTE ADAPTER
24	GRASS BAG COMPONENTS
26	DECALS
28	ELECTRIC START COMPONENTS
30	RECYCLING KITS ACCESSORY
32	SNAPPERIZER ACCESSORY
34	THATCHERIZER ASSEMBLY

# HANDLES & CONTROLS

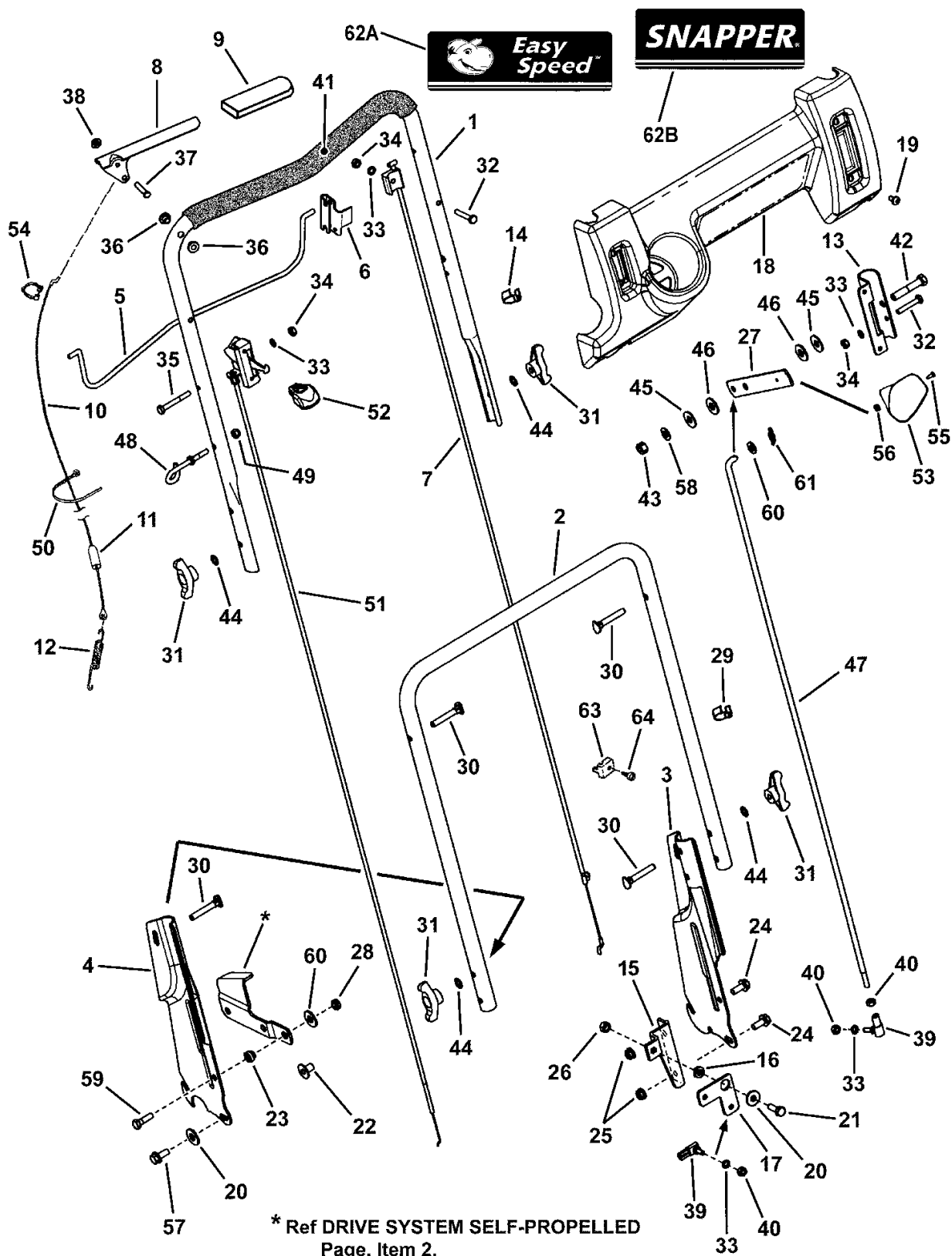

## HANDLES & CONTROLS

Item	Part No	Qty	Description	Note
1	7074411	1	HANDLE, Upper	
2	7074156	1	HANDLE, Middle	
3	7033985	1	HANDLE, Lower LH (Adjustable)	
4	7033986	1	HANDLE, Lower RH (Adjustable)	
5	7074418	1	BAIL, OPC Control	
6	7034872	1	CLIP, Zone Control	
7	7034608	1	* CABLE, Zone Control (52-63/64" Long)	
7	7074141	1	* CABLE, Zone Control (56-5/16" Long)	
7	7078078	1	* CABLE, Zone Control (50-31/64" Long)	
7	7100976	1	* CABLE, Zone Control (53-47/64" Long)	
8	7074473	1	HANDLE, Clutch	
9	7028407	1	GRIP, International Symbol	
10	7034604	1	CABLE, Clutch Control (41-1/4" Long)	
11	7012121	1	COVER, Vinyl	
12	7012122	1	SPRING, Clutch - 21S	
13	7074003	1	BRACKET, Shift	
14	7024641	2	TIE, Wire, 1.29 long, black	
15	7073822	1	BRACKET, Bell Crank	
16	7013849	1	SPACER, .33 x .63 x .156	
17	7073913	1	BELL CRANK	
18	7074140	1	CONTROL PANEL (w/o Electrical Switch Hole)	<i>Used on Manual Start Models</i>
18	7074469	1	CONTROL PANEL (w/Electrical Switch Hole)	<i>Used on electric start models</i>
18	7073826	1	CONTROL PANEL (w/o wheel drive slot)	<i>used on 2167519BFC &amp; 2167519B</i>
19	7091200	4	SCREW, 1/4-20 x 1/2" Pan Head Self-Tap (Torx)	
20	7091130	2	WASHER, .33 x .88 x .09 Flat	
21	7091904	1	SCREW, 5/16-18 x 7/8" Hex Head Cap, GR 5	
22	7090895	1	TEENUT, 5/16-18	<i>or 7090538</i>
23	7012114	1	BUSHING, Differential, .328 x .625 x .41	
24	7090595	2	BOLT, 5/16-18 x 3/4" Hex Flange Lock GR 5	
25	7091070	2	NUT, 5/16-18 Hex Flange Lock, GR 5	<i>or 7090585 or 7091601</i>
26	7091067	1	NUT, 5/16-18 Hex Center Lock	
27	7074113	1	LEVER, Shift	
28	7091606	1	NUT, 5/16-24 Hex Center Lock GR 5	<i>or 7091074</i>
29	7023813	1	CLIP, Wiring Harness	
30	7091189	4	SCREW, 5/16-18 x 1-7/8" Curved Head GR 2	<i>or 7091740</i>
31	7035744	4	KNOB, 5/16-18 Wing (Black)	
31	720727	4	KNOB, 5/16-18 Wing (Black)	<i>Briggs part</i>

### Footnotes:

NOTE: \* Part number and revision is stamped on cable.

# HANDLES & CONTROLS

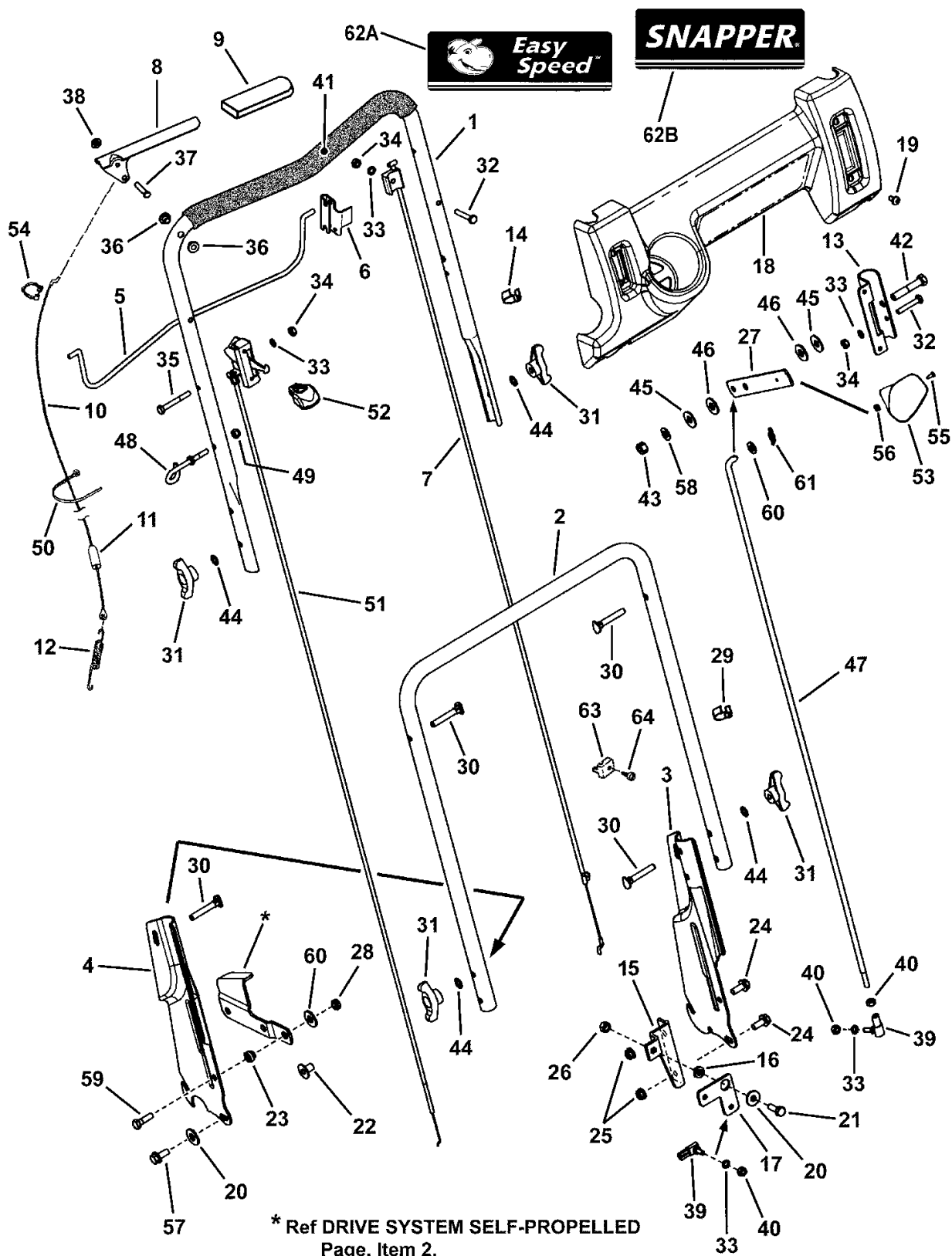

\* Ref DRIVE SYSTEM SELF-PROPELLED  
Page, Item 2.

## HANGLES & CONTROLS

Item	Part No	Qty	Description	Note
32	7079577	2	SCREW, 1/4-20 x 1-1/2" Hex Head Cap GR 5	
33	7090053	5	WASHER, 1/4" Internal Tooth Lock	<i>or 7091023</i>
34	7091100	3	NUT, 1/4-20 Hex	<i>or 7091576</i>
35	7090505	1	SCREW, 1/4-20 x 2" Hex Head Cap, GR 5	
36	7014343	2	BUSHING, .27 x .35 x .4 Flange	
37	7023792	1	PIN, 1/4 x 1-1/2"	
38	7091020	1	PUSH-NUT, 1/4"	
39	7015753	2	BALL JOINT, 1/4-28	
40	7090095	4	NUT, 1/4-28 Hex	
41	7023810	1	FOAM GRIP, 18.75" long	
42	7091305	1	SCREW, 3/8-16 x 2" Hex Head Cap, GR 5	
43	7091585	1	NUT, 3/8-16 Hex Center Lock	
44	7090391	4	WASHER, 5/16" Internal Tooth Lock	
45	7031961	8	WASHER, 7/16" Flat	
46	7028465	2	WASHER, Nylon	
47	7074133	1	ROD, Speed Control (1/4-28 thread)	
48	7028488	1	GUIDE, Rope (1/4-20 thread)	
49	7076978	1	NUT, 1/4-28 Hex GR 5 or B	
50	7012080	1	CABLE-TIE, 7"	
51	7074460	1	THROTTLE CONTROL, (48.5")	<i>used on Briggs models</i>
51	7074138	1	THROTTLE CONTROL, 6.0 KWV (53.25")	<i>used on Kawasaki models</i>
51	7100975	1	THROTTLE CONTROL, RP, D.O.V. Engine (50.0")	<i>used on Briggs DOV engines</i>
52	7075308	1	THROTTLE KNOB (Red)	
53	7075182	1	KNOB, Shift (Red)	
54	7026219	1	CLAMP, 7/8" Double Cable	
55	7091167	1	SCREW, #8-32 x 1/2" Cross Recess Filister Head Machine	
56	7091018	1	NUT, #8-32 Hex	
57	7091151	1	SCREW, 5/16-18 x 1-1/4" Hex Washer Head Self-Tap	
58	7028568	1	WASHER, Belleville	
59	7090238	1	SCREW, 5/16-24 x 1" Hex Head Cap GR 5	
60	7090188	1	WASHER, 11/32" Flat	
61	7034162	1	COTTER PIN, 5/16 Self Lock	
62A	7100183	1	DECAL, Easy Speed, Control Panel	
62B	7100182	1	DECAL, Snapper Control Panel	<i>used on Push models</i>
63	7023153	1	CLAMP, Casing	
64	7023154	1	SCREW, #10-32 x 5/8" Self-Tap	

### Footnotes:

NOTE: \* Part number and revision is stamped on cable.

# CUTTING DECKS, BLADES

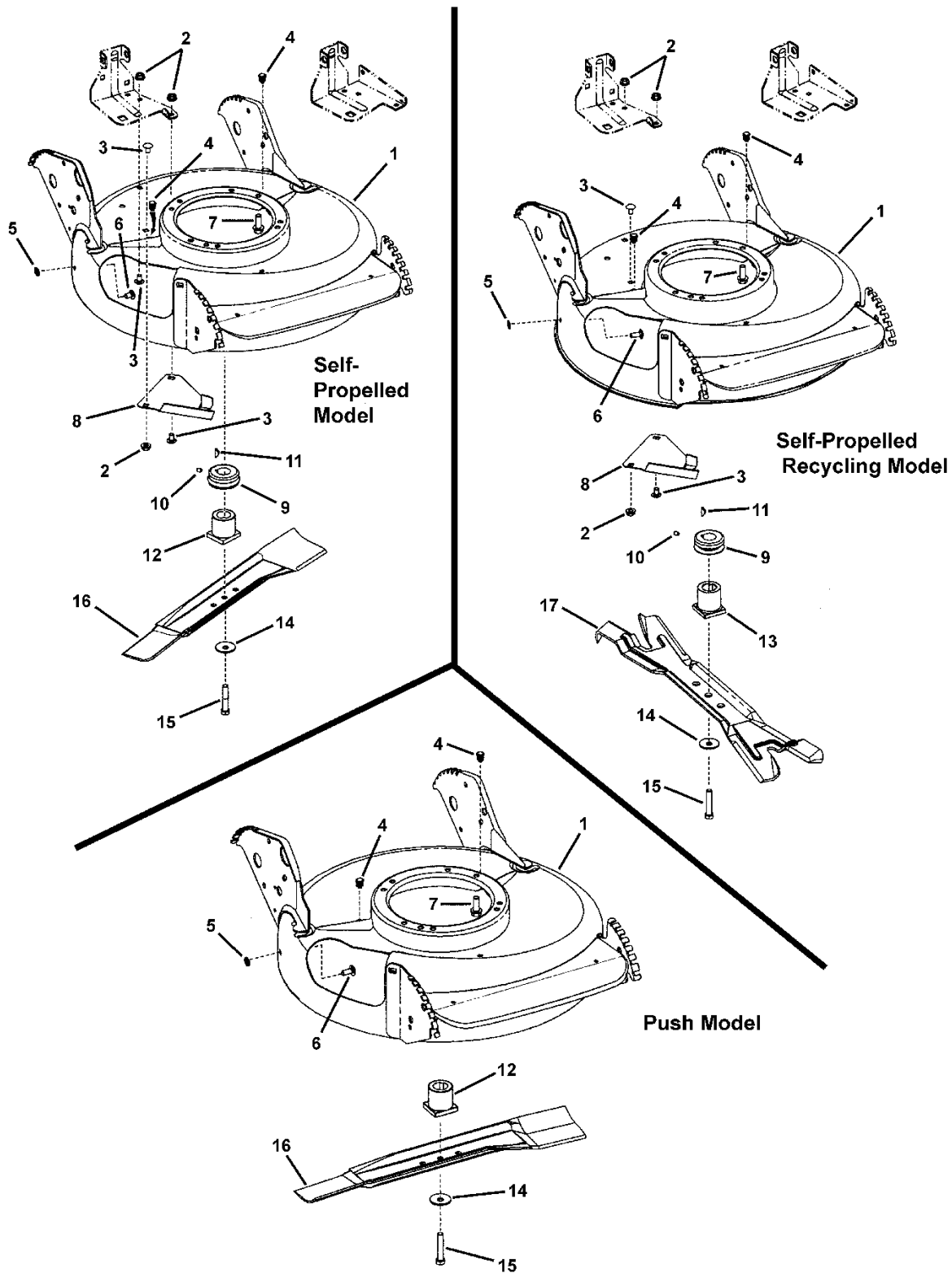



## CUTTING DECKS, BLADES

Item	Part No	Qty	Description	Note
--		1	* ENGINE, Kawasaki 6.0 HP, Mod. FJ180V-DS13-R	<i>used on RP216019KWV</i>
--		1	* ENGINE, Kawasaki 6 HP Mod. FJ180V-BS23-R	<i>used on P216019KWV</i>
--		1	* ENGINE, B&S 675 Series Mod. 126L02-0113-F1	<i>used on N2167519B &amp; NP2167519B</i>
--		1	* ENGINE, B&S 675 Series XRM, B1 Mod. 126T02-0200-B1	<i>used on 2167519B &amp; P2167519B</i>
--		1	* ENGINE, DOV 700 Series Mod. 100602-0121-B1	<i>used on RP2167519BDV</i>
--		1	* ENGINE, B&S 875 Series XIC, F1 Mod. 12S602-0110-F1	<i>used on NP2187519BV</i>
--		1	* ENGINE, B&S 875 Series, Intek 12S502-0112-B1	<i>used on RP2187519BV &amp; P2187519BV</i>
--		1	* ENGINE, B&S 875 Series, Intek, ES, 12S507-0115-B1	<i>used on RP2187519BVE &amp; P2187519BVE</i>
1	7400026	1	WELDMENT, Deck, 21" Non-Adjust Air	<i>finish: red painted but w/o decals</i>
1	7400027	1	WELDMENT, Deck, 21" S.P., HV, Core Model	<i>finish: red painted but w/o decals</i>
1	7400029	1	WELDMENT, Deck, 21" Push, HV, Core Model	<i>finish: red painted but w/o decals</i>
2	7091070	3	NUT, 5/16-18 Hex Flange Lock, GR 5	
3	7090731	3	BOLT, 5/16-18 x 1/2", Short Neck Carriage, GR 5	
4	7046780	2	PLUG, Hole, Polyethylene	
5	7011791	1	RETAINER, 5/16" Bolt	
6	7090001	1	BOLT, 5/16-18 x 3/4" Short Neck Carriage GR 5	<i>or 7091508</i>
7	7090324	3	SCREW, 3/8-16 x 1" Self-Tapping	<i>engine mount bolts</i>
8	7074568	1	COVER, Belt	
9	7015780	1	PULLEY, Engine (25mm I. D. x 2-1/8" O.D.)	
10	7090201	1	SET SCREW, 5/16-18 x 5/16" Hex Socket	
11	7091214	1	KEY, Woodruff #HP-506 Hi-Pro	
12	7015626	1	HUB, Blade Drive, 25 mm I.D.	
13	7101414	1	HUB, Blade, 21" WBM, RD, 2 Position	
14	7012063	2	WASHER, Cone	
15	7090167	1	SCREW, 3/8-24 x 2" Hex Head Cap, GR 5	
16	7026691	1	BLADE, 21" Standard Lift	
17	7026407	1	BLADE, 21" Ninja (Quad Edge)	<i>Used on Recycling Models</i>

### Footnotes:

NOTE: \* Purchase engine parts from engine manufacturer dealer.

**WHEEL BRACKETS, LATCHES (Push)**

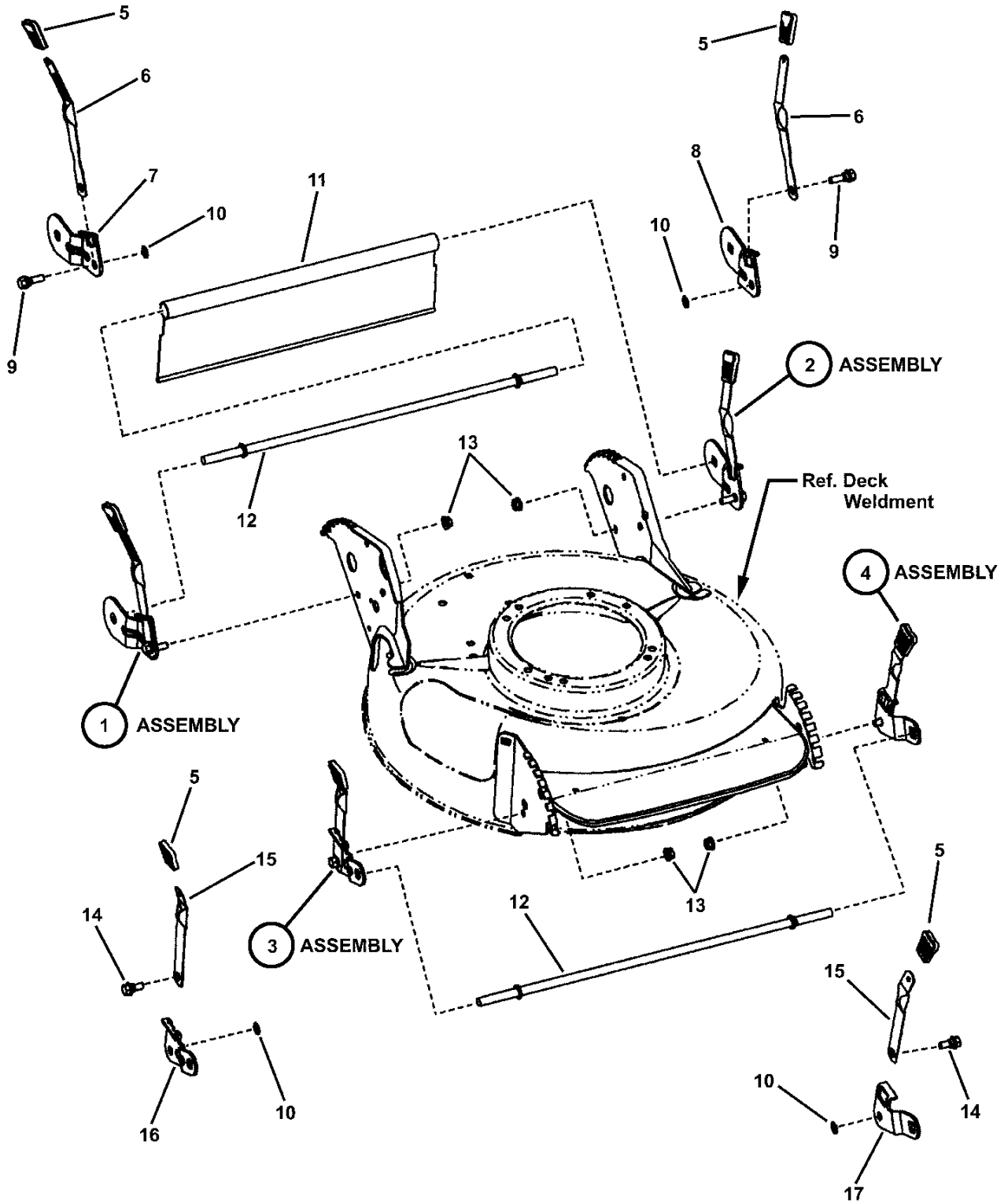

## **WHEEL BRACKETS, LATCHES (Push)**

<b>Item</b>	<b>Part No</b>	<b>Qty</b>	<b>Description</b>	<b>Note</b>
1	7054228	1	ASSY, Wheel Arm, Right Rear (Push)	
2	7054229	1	ASSY, Wheel Arm Left Rear Long (Push)	
3	7051886	1	ASSEMBLY, Right Wheel Arm	
4	7051885	1	ASSEMBLY, Left Wheel Arm	
5	7100633	4	GRIP, Height Latch	
6	7035717	2	LATCH, Height Adjusting (long)	
7	7033776	1	ARM, Wheel, Right Rear	
8	7033775	1	ARM, Wheel, Left Rear	
9	7011078	2	BOLT, 5/16-18 x 1" Hex Washer Face Shoulder	
10	7011791	4	RETAINER, 5/16" Bolt	
11	7035741	1	FOOT GUARD, Long Rear (21 Push)	
12	7021119	2	AXLE, 21"	
13	7091070	4	NUT, 5/16-18 Hex Flange Lock, GR 5	<i>or 7090585 or 7091601</i>
14	7015761	2	BOLT, 5/16-18 x 3/4" Hex Washer Face Shoulder	
15	7012325	2	LATCH, Height	
16	7031017	1	WHEEL ARM, R.H. Front (Round Hole)	
17	7031016	1	WHEEL ARM, L.H. Front (Square Hole)	

### **Footnotes:**

**WHEEL BRACKETS, LATCHES (Self-Propelled)**

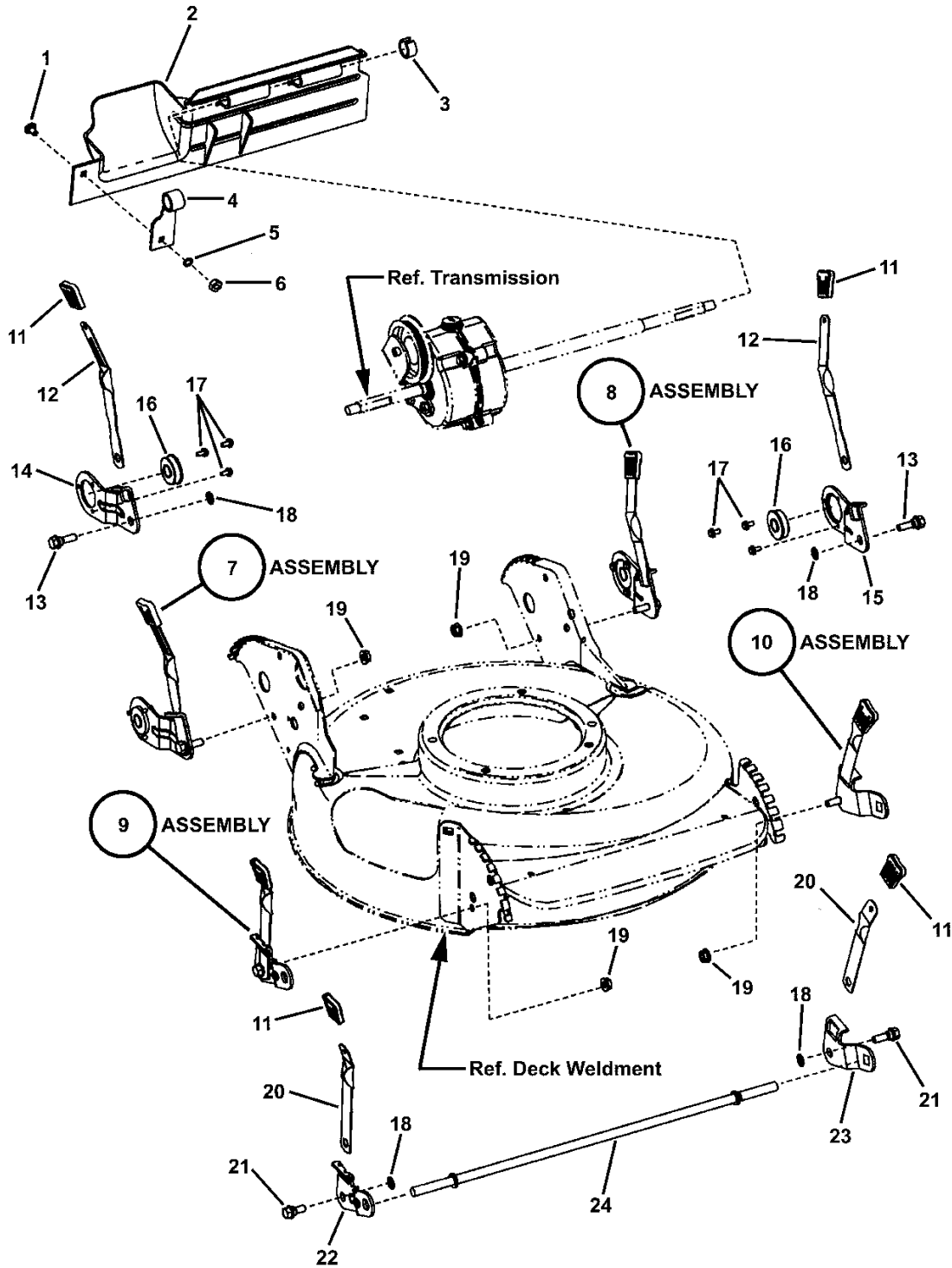

## **WHEEL BRACKETS, LATCHES (Self-Propelled)**

<b>Item</b>	<b>Part No</b>	<b>Qty</b>	<b>Description</b>	<b>Note</b>
1	7090005	1	BOLT, 1/4-20 x 1/2" Short Neck Carriage GR 5	<i>or 7091604</i>
2	7029008	1	FOOT GUARD, Rear	
3	7023791	1	RING, Split (Black)	
4	7012616	1	SUPPORT, Foot Guard	
5	7090053	1	WASHER, 1/4" Internal Tooth Lock	<i>or 7091023</i>
6	7090063	1	NUT, 1/4-20 Hex, GR 5 or B	
7	7054230	1	ASSY, Wheel Arm, Right Rear (S.P.)	
8	7054231	1	ASSY, Wheel Arm Left Rear Long SP21S	
9	7051886	1	ASSEMBLY, Right Wheel Arm	
10	7051885	1	ASSEMBLY, Left Wheel Arm	
11	7100633	4	GRIP, Height Latch	<i>replaces 7027702 (voided)</i>
12	7035717	2	LATCH, Height Adjusting (long)	
13	7011078	2	BOLT, 5/16-18 x 1" Hex Washer Face Shoulder	
14	7032722	1	ARM, Wheel, Right Rear	
15	7032723	1	ARM, Wheel, Left Rear	
16	7012312	2	BEARING, 9/16" I.D.	
17	7091012	6	SCREW, #10-32 x 3/8" Hex Washer Self-Tap	
18	7011791	4	RETAINER, 5/16" Bolt	
19	7091070	4	NUT, 5/16-18 Hex Flange Lock, GR 5	
20	7012325	2	LATCH, Height	
21	7015761	2	BOLT, 5/16-18 x 3/4" Hex Washer Face Shoulder	
22	7031017	1	WHEEL ARM, R.H. Front (Round Hole)	
23	7031016	1	WHEEL ARM, L.H. Front (Square Hole)	
24	7021119	1	AXLE, 21"	

### **Footnotes:**

**FRONT WHEELS**

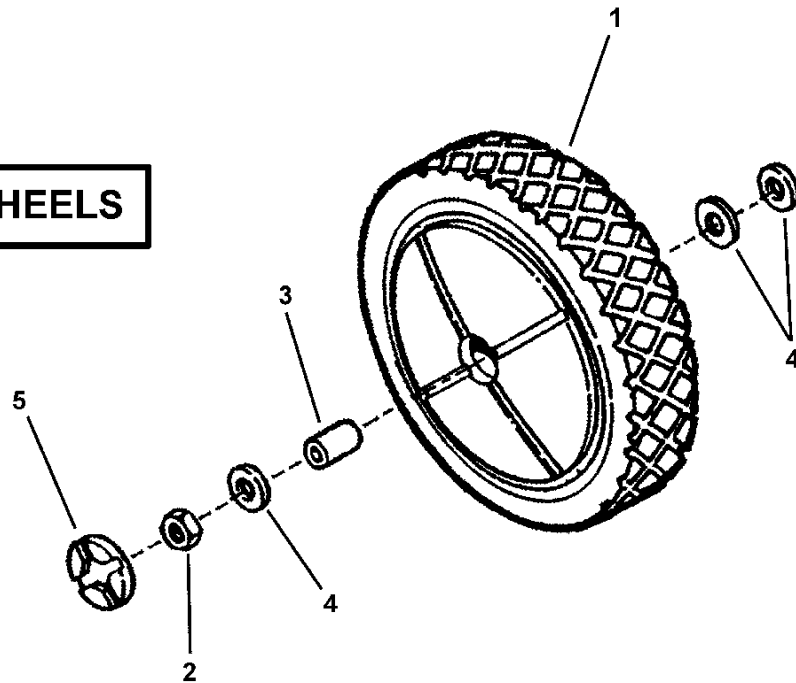

---

**REAR WHEELS**

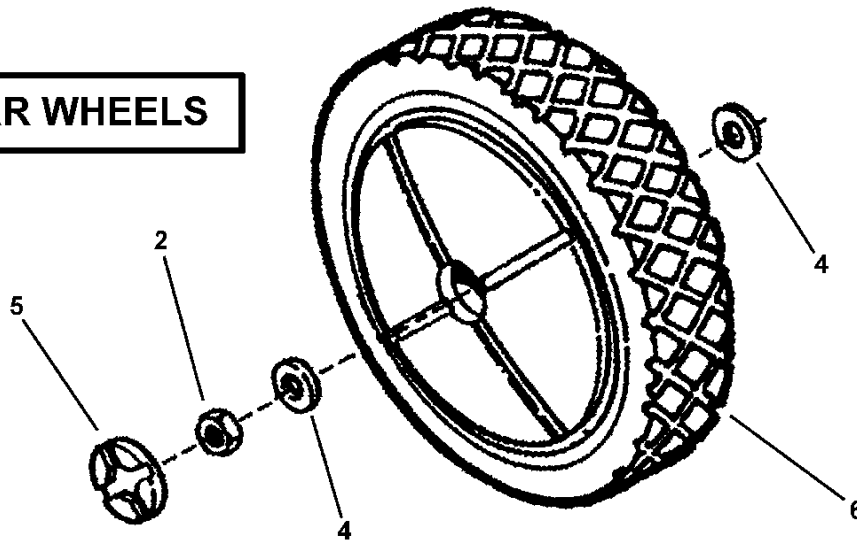

**NOTE:** Always replace wheel nut #7090377 when removing or replacing wheel.

## **WHEELS, FRONT & REAR**

---

<b>Item</b>	<b>Part No</b>	<b>Qty</b>	<b>Description</b>	<b>Note</b>
1	7029010	2	WHEEL, 8 x 1.75" Plastic	
2	7090377	4	NUT, 7/16-20 Hex Center Lock Jam	
3	7012309	2	BUSHING, Axle	
4	7031961	10	WASHER, 7/16" Flat	
5	7017829	4	PLUG, Wheel	
6	7074924	2	WHEEL, 10 x 1.75" Plastic (push)	
6	7029011	2	WHEEL, 10 x 1.75" Plastic (self-propelled)	

### **Footnotes:**

**DRIVE SYSTEM SELF-PROPELLED**

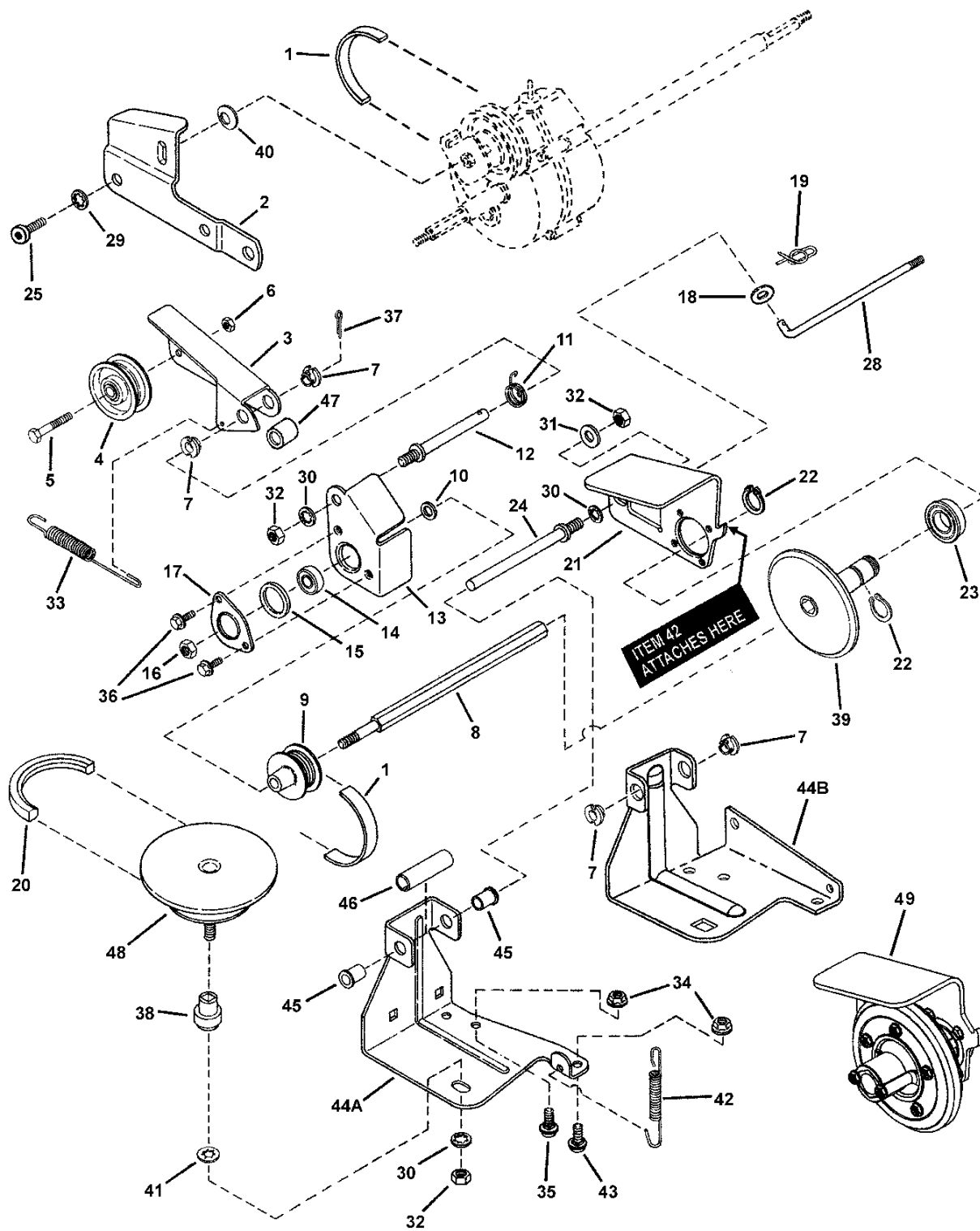



## DRIVE SYSTEM SELF-PROPELLED

Item	Part No	Qty	Description	Note
1	7012354	1	BELT, Poly-V	
2	7034179	1	LINK, Differential (Comm.)	
--	7051921		ASSEMBLY, Clutch Idler (Includes items 3 thru 7)	
3	7032832	1	ARM, Clutch Idler	
4	7012124	1	PULLEY, Idler, V21	
5	7091025	1	SCREW, 1/4-28 x 1-3/8" Hex Head Cap, GR 5	
6	7090303	1	NUT, 1/4-28 Hex Top Lock	
7	7012117	4	BUSHING, 3/8" I.D. Nylon	
8	7072284	1	SHAFT, Hex Drive	
9	7024521	1	PULLEY, Poly-V (2" O.D.)	<i>for non-Commercial models</i>
10	7090188	1	WASHER, 11/32" Flat	
11	7012126	1	SPRING, Idler- Torsion	
12	7012111	1	STUD, Idler (3/8-24 thread)	
13	7031873	1	HOLDER, Bearing (Inner Half)	
14	7028014	1	BALL BEARING, Spherical O.D., .38 I.D.	
15	7011025	1	O-RING, V21	
16	7090289	1	NUT, 3/8-24 Hex Center Lock, GR 5	
17	7031809	1	HOLDER, Bearing (Outer Half)	
18	7091294	1	WASHER, .28 x .63 x .06 Flat	
19	7091629	1	COTTER PIN, .06 x .50 YZ	<i>or 7090673</i>
20	7046784	1	BELT, Engine Drive (Stretch)	
21	7300977A	1	THRUST PLATE, Short	<i>was 7034281</i>
22	7010746	2	RETAINING RING, .625 External	
23	7026693	1	BALL BEARING- 3/4" Bore	
24	7012125	1	GUIDE, Thrust Plate (3/8-24 thread)	
25	7091542	1	SCREW, 5/16-18 x 1/2" Pan Head Self-Tap (Torx)	
26	7015753	1	BALL JOINT, 1/4-28 (not shown)	<i>see Handles &amp; Controls page (item 39)</i>
27	7090095	2	NUT, 1/4-28 Hex (not shown)	<i>see Handles &amp; Controls page (item 40)</i>
28	7074145	1	LINK, Transfer (1/4-28 thread)	
29	7090391	1	WASHER, 5/16" Internal Tooth Lock	
30	7090390	3	WASHER, 3/8" Internal Tooth Lock	
31	7090122	1	WASHER, 3/8" Flat	
32	7091630	3	NUT, 3/8-24 Hex	
33	7012122	1	SPRING, Clutch - 21S	
34	7090585	2	NUT, 5/16-18 Hex Flange Lock, GR 5	<i>or 7091601</i>
35	7090731	1	BOLT, 5/16-18 x 1/2", Short Neck Carriage, GR 5	
36	7090539	2	SCREW, 1/4-20 x 1/2" Hex Flange Self-Tap	<i>or 7091122</i>

### Footnotes:

NOTE: \* Includes Steel Drive Disc Assy (7073528), Bushing (7013893), 3/8-16 Hex Nut (7091302) & item 38.

**DRIVE SYSTEM SELF-PROPELLED**

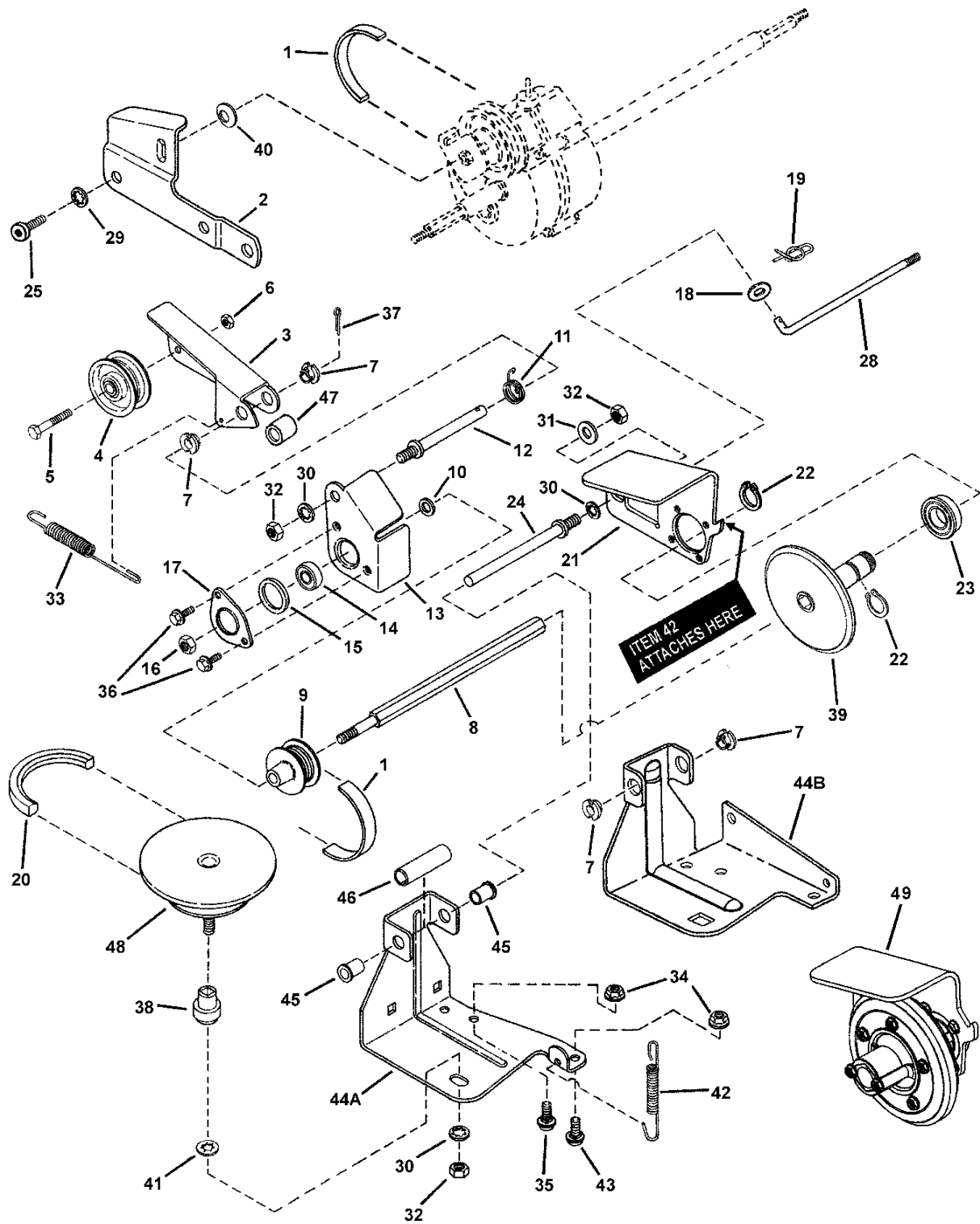

## **DRIVE SYSTEM SELF-PROPELLED**

<b>Item</b>	<b>Part No</b>	<b>Qty</b>	<b>Description</b>	<b>Note</b>
37	7090555	1	COTTER PIN, 3/32 x 1/2"	<i>or 7091597</i>
38	7017696	1	BUSHING, Powdered Metal	
39	7041855	1	DISC, Driven (Cantilever)	
40	7011724	1	WASHER, 44 x .78 x .025 Curved	
41	7013847	1	RETAINER, 3/8" Bolt	
42	7029025	1	SPRING, Wheel Drive	
43	7091026	1	BOLT, 5/16-18 x 5/8" Short Neck Carriage GR 5	<i>or 7090799</i>
--	7059462	1	ASSEMBLY, Deck Bracket (Incl. items 7 & 44A)	<i>Used on RP2167519B, RP2167519BDVFC, RP217019BV, RP2187519BV, RP216019KWV &amp; RP2167519BDV</i>
--	7052987	1	ASSEMBLY, Deck Bracket (Incl. items 44B, 45 & 46)	<i>Used on RP217019BVE, P2167519B, P2167519BFC, P2187519BV, P2187519BVE, P2187519BVFC &amp; RP2187519BVE</i>
44A	--	1	BRACKET, Deck, (Use 7033774 & 7017696)	<i>used on early models</i>
44B	7033774	1	BRACKET, Deck	
45	7012306	2	BUSHING, Flange, .381 x .625 x .62	
46	7021758	1	SPACER, .500 x .65 x 1.75	
47	7100447	1	SPACER, Idler Arm	
48	7061275		* KIT, Drive Disc Assembly	
49	7501000		ASSEMBLY, Driven Disc (replaces items 21-24, 30-32, & 39)	<i>was 7073390 or 7053225</i>

### **Footnotes:**

NOTE: \* Includes Steel Drive Disc Assy (7073528), Bushing (7013893), 3/8-16 Hex Nut (7091302) & item 38.

# TRANSMISSION (DIFFERENTIAL)

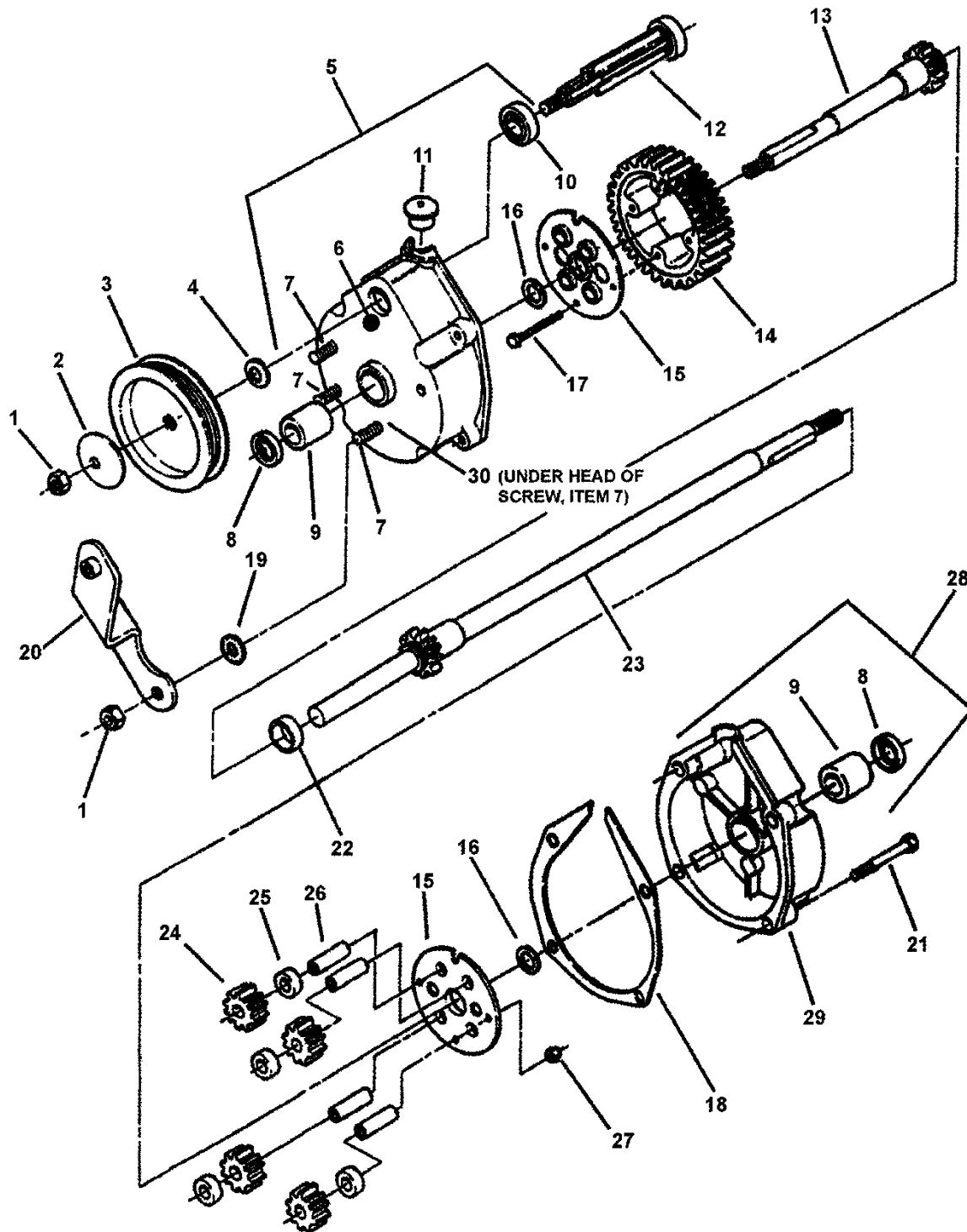

## TRANSMISSION (DIFFERENTIAL)

Item	Part No	Qty	Description	Note
--	7053943	1	ASSEMBLY, Transmission (Incl. items 1 thru 30)	<i>was 7059070</i>
1	7092062	4	NUT, 5/16-18 Hex Lock	<i>or 7011201</i>
2	7092063	1	WASHER, Cone	
3	7019213	1	PULLEY, Poly-V Belt (3.5" O.D.)	
4	7011724	2	WASHER, 44 x .78 x .025 Curved	
5	7053942	1	ASSEMBLY, Right Housing (Incl. items 6, 7, 8, 9, 10 & 30)	<i>was 7053941</i>
6	7029034	1	HOUSING, Right Side	
7	7014155	3	SCREW, 5/16-24 x 1-1/8" Rib Neck, GR 5	
8	7012314	1	SEAL, 5/8" Internal Diameter	
9	7029035	1	BEARING, Tapered - (Differential Housing)	
10	7073963	1	BALL BEARING, 7/16 I.D., 1/1/8" O.D.	<i>was 7011767</i>
11	7016544	1	PLUG, Transmission Housing	
12	7050767	1	ASSEMBLY, Input Gear	
13	7051932	1	ASSEMBLY, Short Axle	
14	7012495	1	GEAR, Differential (46 Tooth)	
15	7031970	2	PLATE, 46T Gear	
16	7031965	2	WASHER, Thrust, 3/4" I.D.	
17	7090557	4	SCREW, #10-32 x 1-1/2" Hex Head Cap GR 5	
18	7011774	1	GASKET, Housing	
19	7090189	3	WASHER, 5/16" Internal/External Tooth Lock	
20	7051903	1	WELDMENT, Differential Bracket	
21	7092064	4	SCREW, 1/4-20 x 1" Hex washer Self-Tap	<i>or 7091825</i>
22	7012543	1	SPACER, Axle Gear	
23	7051933	1	ASSEMBLY, Long Axle	
24	7021115	4	GEAR, Pinion (12 tooth)	
25	7012500	4	SPACER, Pinion Gear	
26	7011110	4	SHAFT, Pinion	
27	7090376	4	NUT, #10-32 Hex Nyloc	
28	7053939	1	ASSY, Left Housing (Incl. items 8, 9 & 29)	<i>was 7053938</i>
29	7029033	1	HOUSING, Left	
30	7024442	3	GASKET, 5/8" O. D.	
--	7061017	32 oz.	* "00" Grease	<i>not shown</i>

### Footnotes:

NOTE: \* Maximum capacity of transmission case is 4 oz. DO NOT OVERFILL!

# SIDE CHUTE ADAPTER

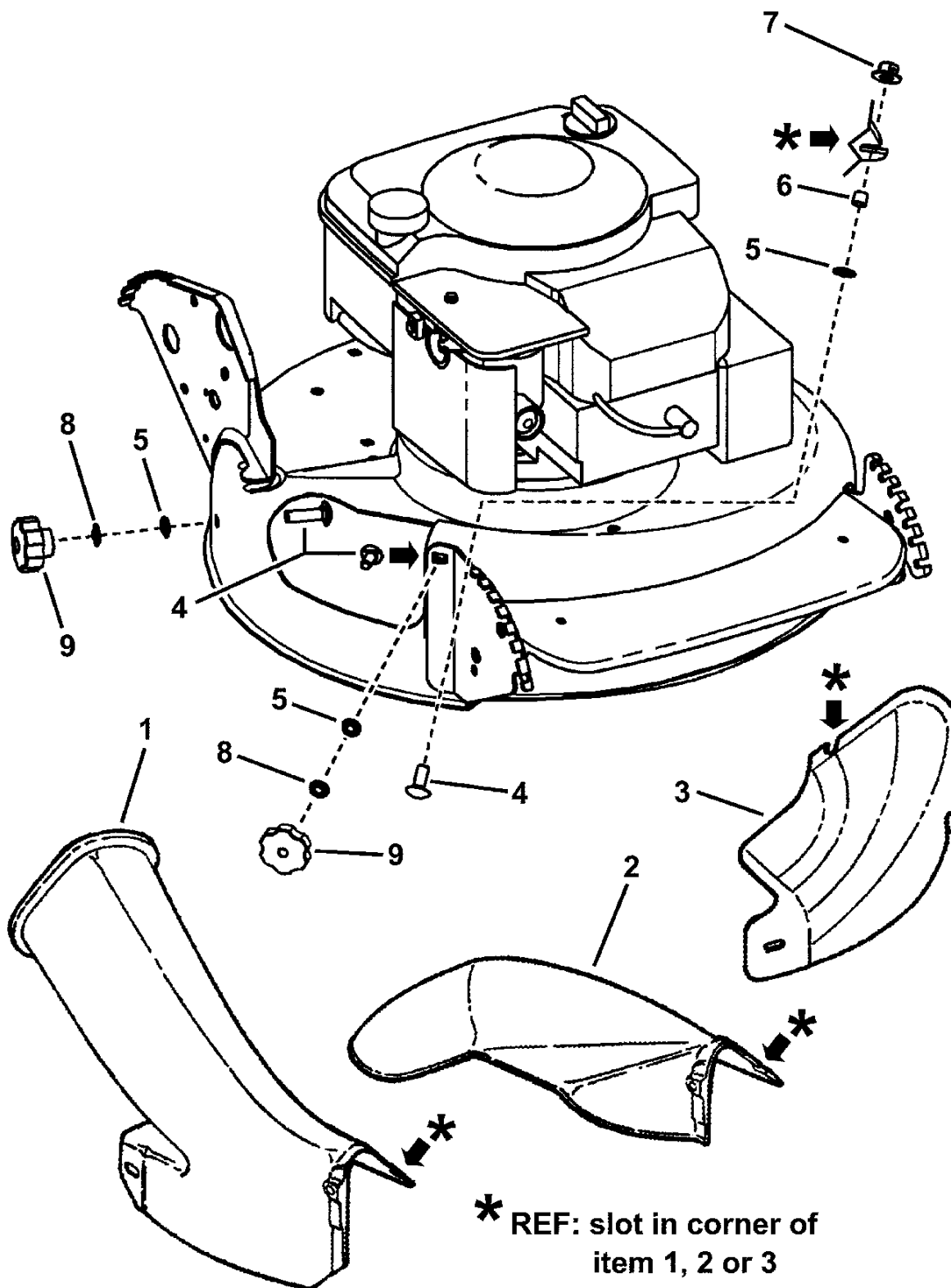

## **SIDE CHUTE ADAPTER**

---

<b>Item</b>	<b>Part No</b>	<b>Qty</b>	<b>Description</b>	<b>Note</b>
1	7047081	1	ADAPTER, Grass Bag	<i>see Grass Bag Accessory page</i>
2	7042965	1	CHUTE, 21" Side	
3	7029149	1	COVER, 21" Deck	
4	7090001	3	BOLT, 5/16-18 x 3/4" Short Neck Carriage GR 5	
5	7011791	3	RETAINER, 5/16" Bolt	
6	7024340	1	SPACER, .316 I.D. x .375 O.D. x .310 thick	
7	7090951	1	NUT, 5/16-18 Hex Large Flange Center Lock	
8	7090189	2	WASHER, 5/16" Internal/External Tooth Lock	
9	7101022	2	KNOB, Fluted, 5/16-18 x 1/2"	

### **Footnotes:**

# GRASS BAG COMPONENTS

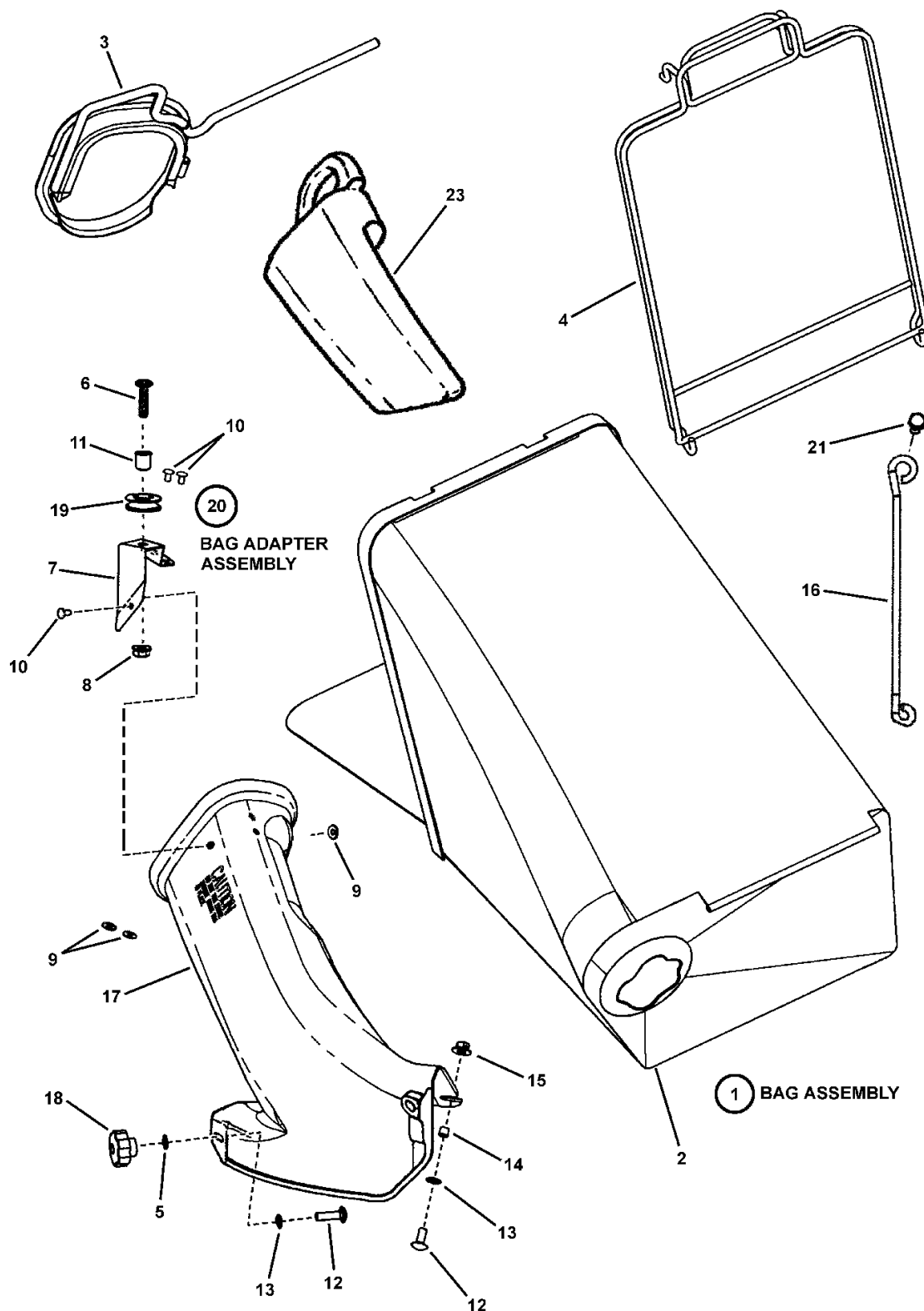



## GRASS BAG COMPONENTS

Item	Part No	Qty	Description	Note
1	7058571	1	BAG ASSEMBLY, (Door)	<i>includes items 2, 3 &amp; 4</i>
2	7075765	1	GRASS BAG, (Door w/Gray Letters)	
3	7042489	1	CONNECTOR, Grass Bag (weldment)	
4	7051906	1	ASSEMBLY, Bag Wire (12" Wide)	
5	7090189	2	WASHER, 5/16" Internal/External Tooth Lock	
6	7091984	1	SCREW, 5/16-18 x 1-1/4" Pan Head Machine	
7	7047082	1	BRACKET, Rope Guide	
8	7090585	2	NUT, 5/16-18 Hex Flange Lock, GR 5	<i>or 7091601</i>
9	7072107	3	WASHER, 15/32" Flat	
10	7013860	3	RIVET, 3/16 x .344	
11	7012306	1	BUSHING, Flange, .381 x .625 x .62	
12	7090001	3	BOLT, 5/16-18 x 3/4" Short Neck Carriage GR 5	<i>or 7091508</i>
13	7011791	3	RETAINER, 5/16" Bolt	
14	7024340	1	SPACER, .316 I.D. x .375 O.D. x .310 thick	
15	7090951	1	NUT, 5/16-18 Hex Large Flange Center Lock	
16	7043327	1	BRACE, Bag Adapter	<i>Kawasaki models only</i>
17	7047081	1	ADAPTER, Grass Bag	
18	7100516	2	KNOB, Fluted, 5/16-18 x .633	
19	7024228	1	PULLEY, Nylon	
20	7058037	1	ASSY, Grass Bag Adapter	<i>includes items 6, 7, 8, 9, 10, 11, 17 &amp; 19</i>
21	7078102	1	SCREW, M6 x 1.0 x 30MM Hex Head Cap	<i>Kawasaki models only</i>
22	7078101	1	SLEEVE, .237/.242 ID x .3135/.3185 x .748 (not shown)	<i>Kawasaki models only</i>
23	7016814	1	PLUG, Chute Adapter	

### Footnotes:

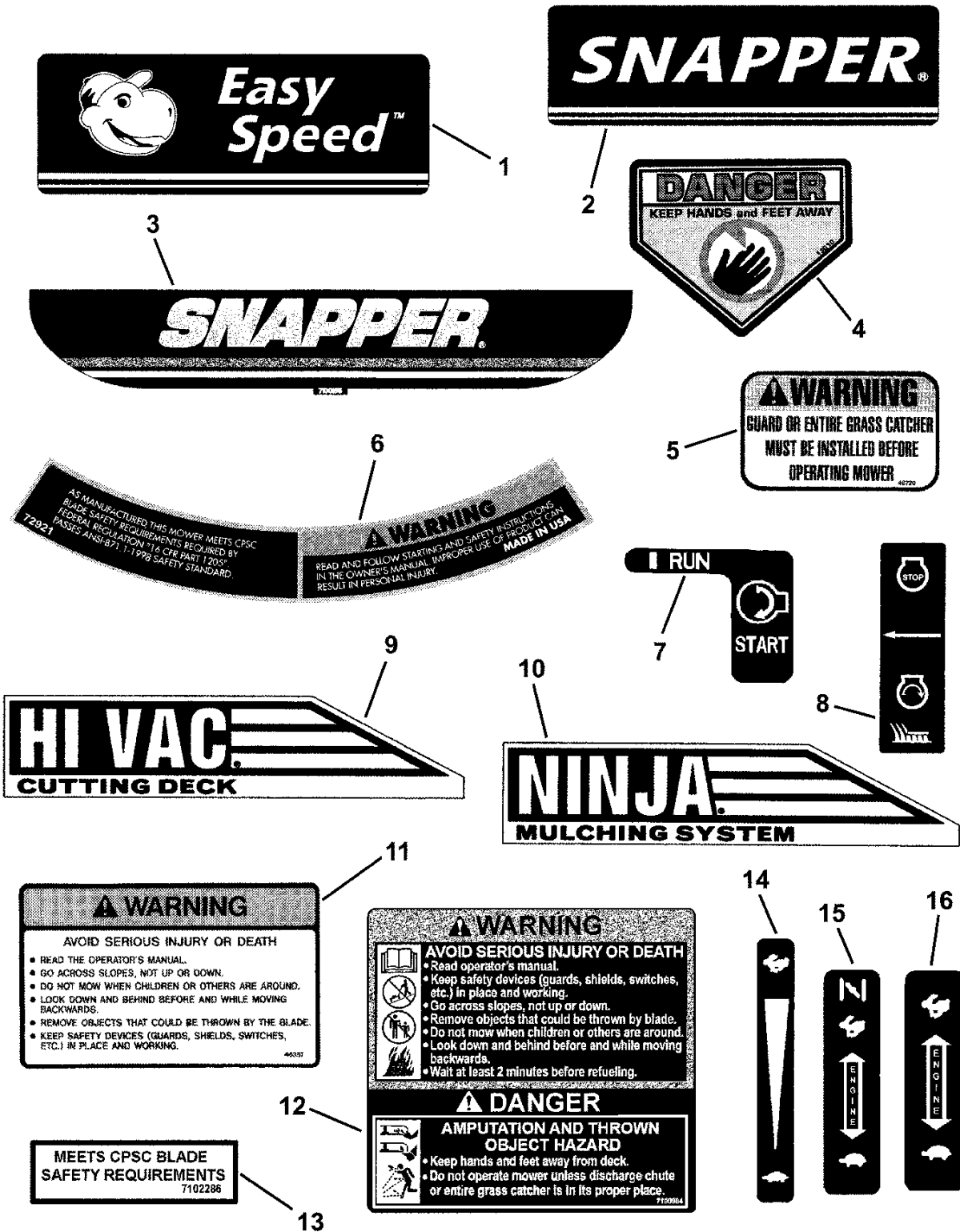

## DECALS

Item	Part No	Qty	Description	Note
1	7100183	1	DECAL, Easy Speed, Control Panel	
2	7100182	1	DECAL, Snapper Control Panel	
3	7100185	1	DECAL, SNAPPER, Steel Decks	
4	7013010	1	DECAL, Danger, Cut Finger	
5	7046720	1	DECAL, Chute/Deflector	
6	7072921	1	DECAL, Warning (Deck)	
7	7075688	1	DECAL, Ignition Switch	
8	7029782	1	DECAL, OPC Bail (International Symbol)	
9	7100398	1	DECAL, Hi Vac Cutting Deck	
10	7100410	1	DECAL, NINJA, Mulching System	
11	7046357	1	DECAL, Warning	
12	7100984	1	DECAL, Warning/Danger Walk-Behind Mowers	
13	7102286	1	DECAL, CPSC Blade	
14	7075471	1	DECAL, Speed Shift	
15	7075524	1	DECAL, Throttle Control, KWV	
16	7075532	1	DECAL, Throttle Control, B&S	

### Footnotes:

# ELECTRIC START COMPONENTS

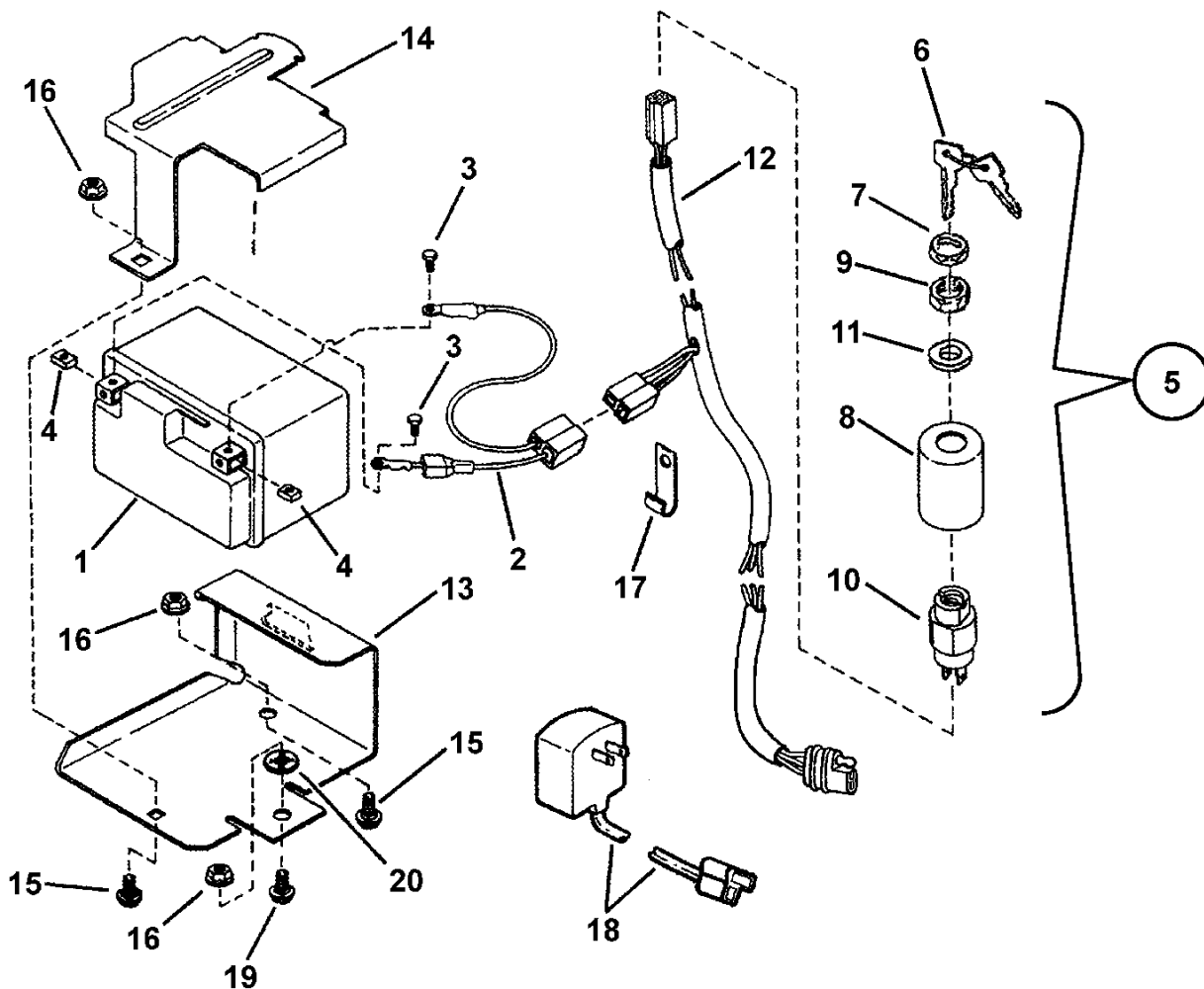

STARTER MOTOR

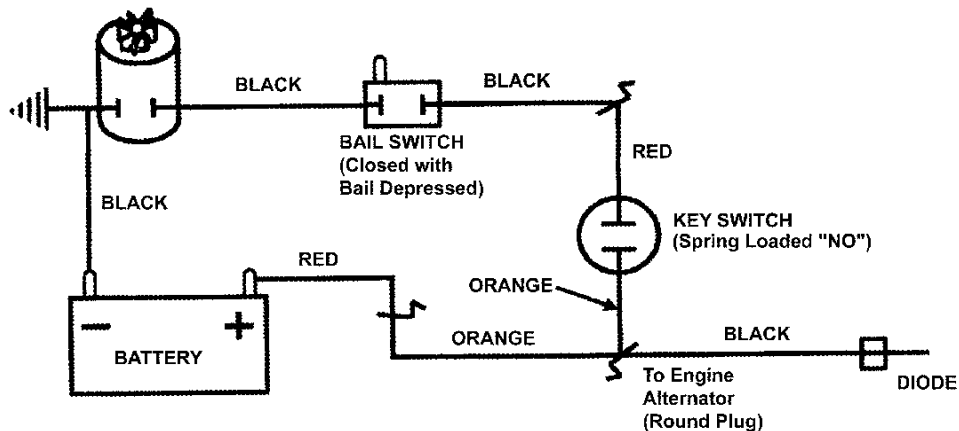

BATTERY WIRING SCHEMATIC FOR BRIGGS ENGINE

## ***ELECTRIC START COMPONENTS***

---

<b>Item</b>	<b>Part No</b>	<b>Qty</b>	<b>Description</b>	<b>Note</b>
1	7067012	1	* KIT, Battery 12V	
1	7067012	1	BATTERY, 12 Volt, 35 CCA	<i>or 7019763</i>
2	7015488	1	HARNESS, Battery	
3	7043977	2	SCREW, #10-24 x 1/2" Pan Head Machine	
4	7090932	2	NUT, #10-24 Square	
5	7041710	1	SWITCH ASSEMBLY (Incl. items 6 thru 11)	
6	7011138	1	KEY, (Set of Two)	
7	7023506	1	BEZEL, (Seal & Face Nut)	
8	7029080	1	COVER, Switch	
9	7012685	1	NUT, 5/8-32 Hex Lock	
10	7028765	1	SWITCH, Ignition (spring loaded ON/OFF 2 prong)	
11	7016132	1	SPACER	
12	7078025	1	WIRING HARNESS, B&S WBM	<i>similar to 7074383</i>
13	7032906	1	BRACKET, Battery	
14	7036132	1	COVER, Battery	
15	7090731	2	BOLT, 5/16-18 x 1/2" Short Neck Carriage GR 5	
16	7090585	3	NUT, 5/16-18 Hex Flange Lock, GR 5	<i>or 7091601</i>
17	7012652	1	CLIP, Wiring	
18	206838YP	1	CHARGER, Battery (120 Volt; 60 Hertz)	<i>or 7018834</i>
19	7091026	1	BOLT, 5/16-18 x 5/8" Short Neck Carriage GR 5	<i>or 7090799</i>
20	7011791	1	RETAINER, 5/16" Bolt	

### **Footnotes:**

NOTE: \* For battery (120V/12V) and charger kit order 7061267.

**7061200 RECYCLING COVER KIT**

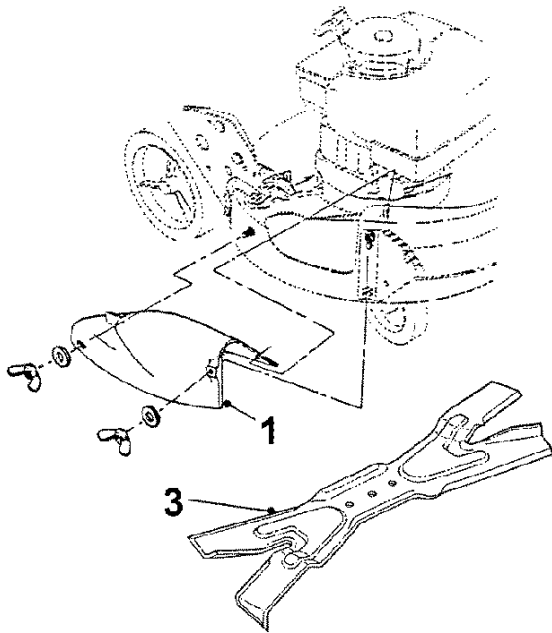

**7061201 RECYCLING PLUG KIT**

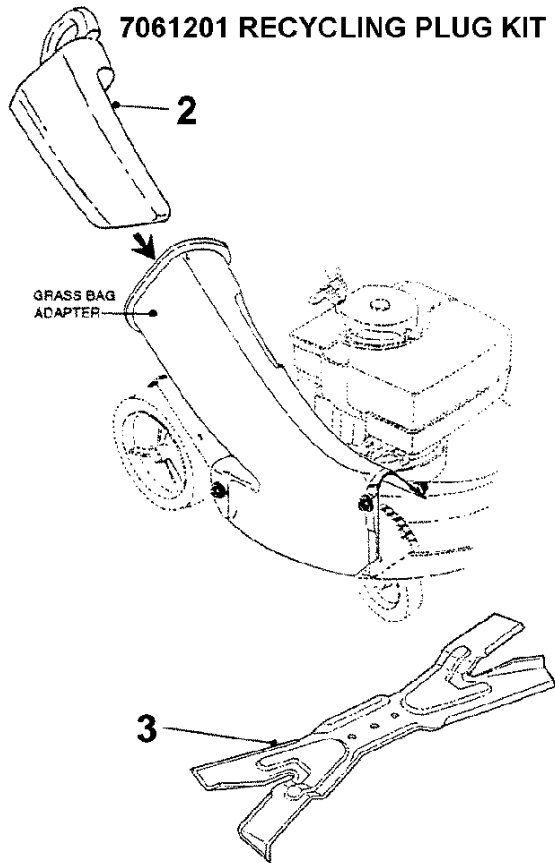

## **RECYCLING KITS ACCESSORY**

---

<b>Item</b>	<b>Part No</b>	<b>Qty</b>	<b>Description</b>	<b>Note</b>
--	7061200		KIT, Recycling Cover (Includes items 1 & 2 shown below)	<i>for 4HP &amp; above engines</i>
--	7061201		KIT, Recycling Plug (Incl. items 1 & 2 shown below)	<i>for 4HP &amp; above engines</i>
1	7029149	1	COVER, 21" Deck	
2	7016814	1	PLUG, Chute Adapter	
3	7026407	1	BLADE, 21" Quad Edge Ninja	

**Footnotes:**

**SNAPPERIZER ACCESSORY**

---

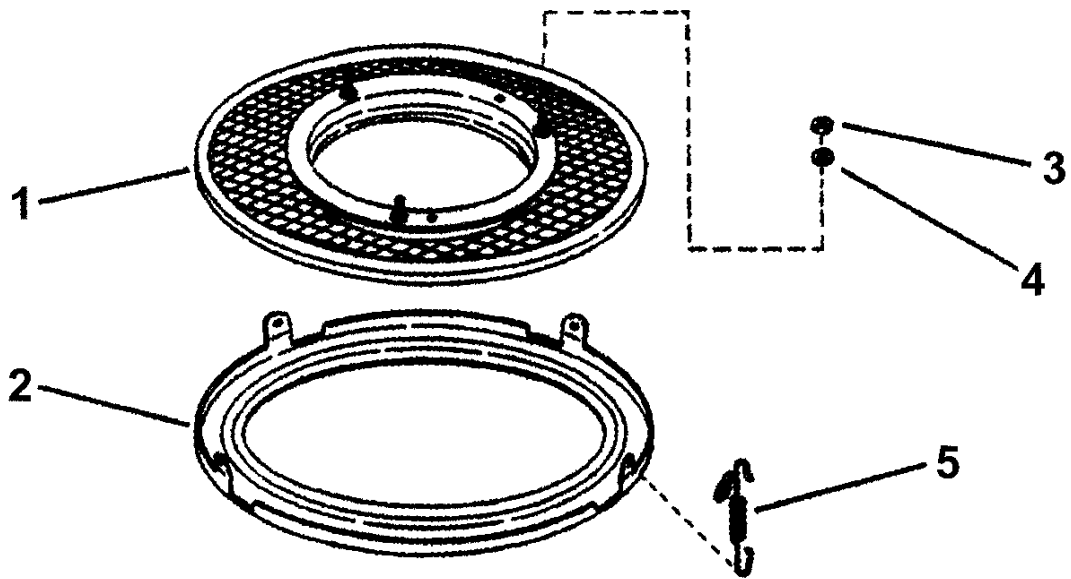



## **SNAPPERIZER ACCESSORY**

---

<b>Item</b>	<b>Part No</b>	<b>Qty</b>	<b>Description</b>	<b>Note</b>
--	7063041		KIT, Snapperizer (Incl. items 1 thru 5)	<i>(for "FR" &amp; "M" type outlip decks)</i>
1	7051243	1	SCREEN, Fastener Assembly	
2	7072002	1	RING, Bottom (22.60" Inside Diameter)	
3	7091297	3	NUT, 5/16-24 Hex, GR 5	
4	7090187	3	WASHER, 5/16" Split Lock	
5	7012587	3	SPRING	

**Footnotes:**

# THATCHERIZER ASSEMBLY

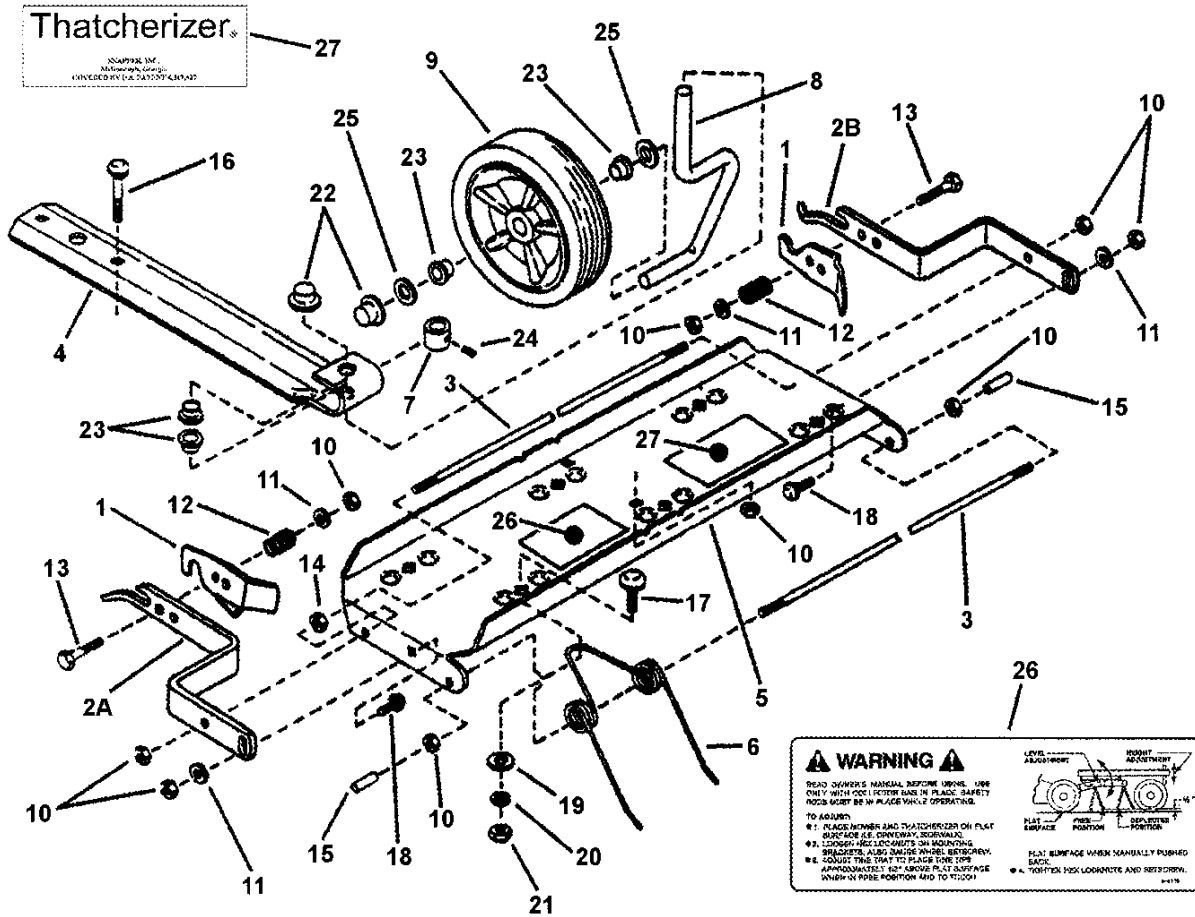

## THATCHERIZER ASSEMBLY

Item	Part No	Qty	Description	Note
--	7061256		KIT, Thatcherizer (Incl. items 1 thru 27)	
1	7032891	2	LATCH, Frame Attachment	
2A	7026572	1	BAR, Mount (Right Hand)	
2B	7026573	1	BAR, Mount (Left Hand)	
3	7018499	2	ROD, Tine	
4	7018700	1	SUPPORT, Wheel	
5	7019948	1	TRAY, Tine	
6	7018496	6	SPRING, Tine Thatching	was 7060574
7	7014100	1	BUSHING, Wheel Adjuster	
8	7018493	1	AXLE, Wheel	
9	7018189	1	WHEEL, 7.00 x 1.50 Gage	
10	7091705	10	NUT, 1/4-20 Hex Top Lock	was 7090761 (only 9 shown)
11	7091294	4	WASHER, 1/4" Flat	was 7090055
12	7022425	2	SPRING, Compression	
13	7090825	2	BOLT, 1/4-20 x 1-1/4" Hex, GR 5	
14	7091576	2	NUT, 1/4-20 Hex, GR 5	was 7090063
15	7022424	2	CAP, Vinyl	
16	7090015	2	BOLT, 1/4-20 x 2-1/2" Square Neck Carriage	only 1 shown
17	7091303	6	BOLT, 5/16-18 x 1" Square Neck Carriage, GR 5	was 7090383 (only 1 shown)
18	7091530	2	BOLT, 1/4-20 x 3/4" Square Neck Carriage, GR 5	was 7090074
19	7014098	6	WASHER, Reinforcing	only 1 shown
20	7090187	6	WASHER, 5/16" Split Lock	only 1 shown
21	7091511	6	NUT, 5/16-18 Hex, GR 5	was 7090196 (only 1 shown)
22	7014101	2	NUT, 1/2" Push	
23	7014342	4	BEARING, Nylon	
24	7014103	1	SET SCREW, 5/16-18 x 1/4"	(slotted headless, cup point)
25	7090250	2	WASHER, 1/2" Flat	
26	7014115	1	DECAL, Adjustment	
27	7014062	1	DECAL, Thatcherizer	

### Footnotes:





*Parts Manual for*

# **SNAPPER<sup>®</sup>**

## **21" STEEL DECK WALK BEHIND MOWERS SERIES 19**

IT IS THE POLICY OF BRIGGS & STRATTON CORP. TO IMPROVE ITS PRODUCTS WHENEVER IT IS POSSIBLE AND PRACTICAL TO DO SO. WE RESERVE THE RIGHT TO MAKE CHANGES OR ADD IMPROVEMENTS AT ANY TIME WITHOUT INCURRING ANY OBLIGATION TO MAKE SUCH CHANGES ON PRODUCTS MANUFACTURED

**Briggs & Stratton Yard Power Products Group**

535 Macon Road  
McDonough, GA, 30253 U.S.A.  
800-935-2967

[www.snapper.com](http://www.snapper.com)

Copyright © 2008 Briggs & Stratton Corporation  
Milwaukee, WI USA. All Rights Reserved

**Manual No. 7006149**  
**Revision B, 7/8/2008**  
**TP 400-5187-B-WB-N**