

SNAPPER®

SERIES 14

REAR ENGINE RIDING MOWERS

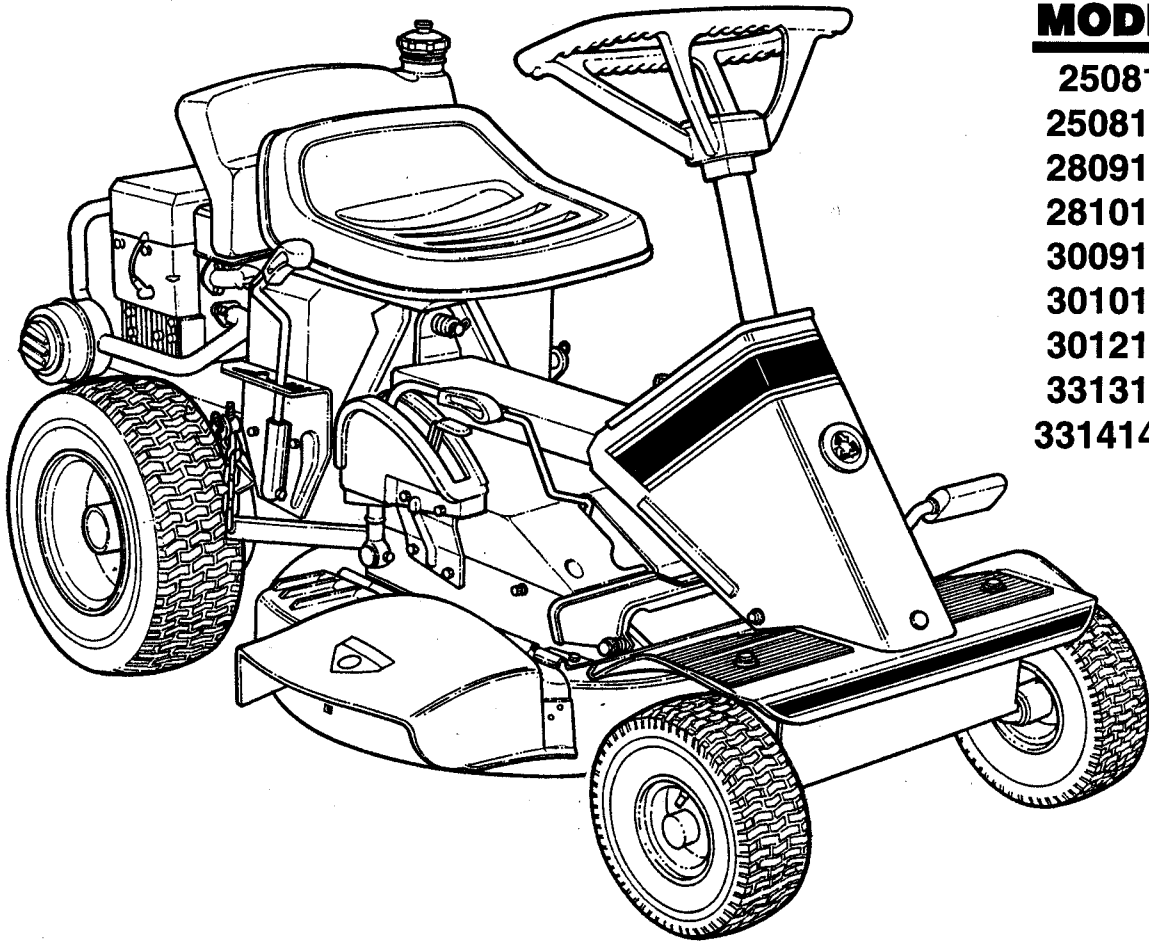

MODELS

- 250814B
- 250814BE
- 280914BE
- 281014BE
- 300914BE
- 301014BE
- 301214BE
- 331314BE
- 331414KVE

MODEL NUMBER EXPLANATION

PREFIX		BODY		SUFFIX	
33		1414		KVE	
CUTTING WIDTH	ENGINE HP	SERIES DESIGNATION	ENGINE AND OPTIONS		

PREFIX EXPLANATION		BODY EXPLANATION
25-25' Cutting Width	09-9hp Engine	14-Series Designation
28-28' Cutting Width	10-10hp Engine	
30-30' Cutting Width	12-12hp Engine	SUFFIX EXPLANATION
33-33' Cutting Width	13-13hp Engine	B-Briggs & Stratton Engine
08-8hp Engine	14-14hp Engine	K-Kohler Engine
		V-Overhead Valve Engine
		E-Electric Start

Thank you for buying a SNAPPER Product! Before operating your **SERIES 14 REAR ENGINE RIDER**, read this manual carefully and pay particular attention to the "IMPORTANT SAFETY INSTRUCTIONS" on page 2. Remember that all power equipment can be dangerous if used improperly. Also keep in mind that safety requires careful use in accordance with the operating instructions and common sense!

IMPORTANT SAFETY INSTRUCTIONS

WARNING: This powerful cutting machine is capable of amputating hands and feet and can throw objects that can cause injury and damage! Failure to observe the following SAFETY instructions could result in serious injury or death. Carefully read this manual and question your dealer if something is not clear. Should the dealer be unable to answer to your satisfaction, write or call the Customer Service Department at SNAPPER, McDonough, Georgia, 30253 (Phone 404-954-2500).

PROTECTION FOR CHILDREN

1. DO NOT allow children in yard when machine is operated (even with the blade OFF).
2. DO NOT allow children to ride on machine or on attachments (even with the blade OFF).
3. DO NOT allow pre-teenage children to operate machine.
4. Only responsible teenagers with mature judgement shall be allowed to operate machine and only under close supervision.

PROTECTION AGAINST TIPOVERS

1. DO NOT operate machine on slopes exceeding 15 degrees (27% grade).
2. On slopes above 10 degrees (18% grade), exercise extreme CAUTION. Turn blade OFF when traveling uphill, also reduce speed and avoid sharp turns.
3. Avoid uphill starts. If machine is stopped going uphill, turn blade OFF and back slowly down the slope.
4. DO NOT mow under any condition where traction or stability is doubtful without first test driving over the terrain with blade OFF.
5. Stay alert for holes and other hidden hazards. Keep away from ditches, washouts, culverts, fences and protruding objects.
6. DO NOT mow back and forth across face of slopes.
7. KEEP A SAFE DISTANCE (at least three feet) away from edge of ditches and other drop offs.

OTHER IMPORTANT PRECAUTIONS

1. Read and follow operator's manuals and instructions furnished with attachments.
2. Only mature, responsible persons shall operate the machine.
3. Mount and dismount the machine from left side.
4. Wear appropriate protective clothing when mowing, such as, long pants and substantial footwear, not barefoot or with open sandals.
5. Practice operation of machine with blade OFF to learn controls and develop skill.
6. Persons under the influence of alcohol or drugs must NOT operate machine.
7. Know how to STOP blade and engine quickly in preparation for emergencies.
8. Keep people and pets a safe distance from machine.
9. Shields, deflectors, switches, blade controls and other safety devices must be in proper position and functional.

OTHER IMPORTANT PRECAUTIONS

10. Clear area to be worked of wire, rocks and other objects that could cause injury if thrown by blade.
11. STOP blade, STOP engine and remove key when leaving machine.
12. DO NOT operate machine unless properly seated with feet on foot rests or pedal.
13. Keep hands and feet away from rotating blade underneath deck. Never place foot on ground while blade is ON or when machine is in motion.
14. Turn blade OFF, STOP engine and wait for blade to STOP before attempting to unclog grass or leaves to prevent loss of fingers or hand.
15. Blade must be switched OFF except when cutting grass. Set cutter in highest position when mowing over rough ground.
16. Deflector or grass catcher must be in position. Never point discharge at people, passing cars, windows or doors. Watch out for traffic when crossing or near roadways.
17. Operate in reverse only after careful observation of entire area behind the machine. DO NOT mow in reverse unless absolutely necessary.
18. Service machine and make adjustments only when engine is stopped.
19. Have machine serviced by an authorized SNAPPER dealer at least once a year and have the dealer install any new SAFETY devices.
20. Use only genuine SNAPPER replacement parts to assure that original standards are maintained.
21. Tighten all nuts, bolts and screws frequently, then check, adjust, repair or replace brakes as needed.
22. Lubricate machine at intervals specified in manual to prevent controls from binding.
23. Mow only in daylight or with good artificial light.
24. Handle gasoline with care! Never remove cap while engine is running. Fill tank outdoors only with engine STOPPED and cool. Clean spilled gasoline from machine. Store gasoline in approved container, out of the reach of children, in well ventilated, unoccupied building.
25. DO NOT change engine governor speed settings or overspeed engine.
26. Check grass catcher components frequently for signs of wear or deterioration and replace as needed to prevent injury from items going through weak or worn spots.
27. Exercise CAUTION when pulling loads. Limit loads to those you can safely control and attach loads to hitch plate as specified with SNAPPER attachment instructions.

Section I- FAMILIARIZATION

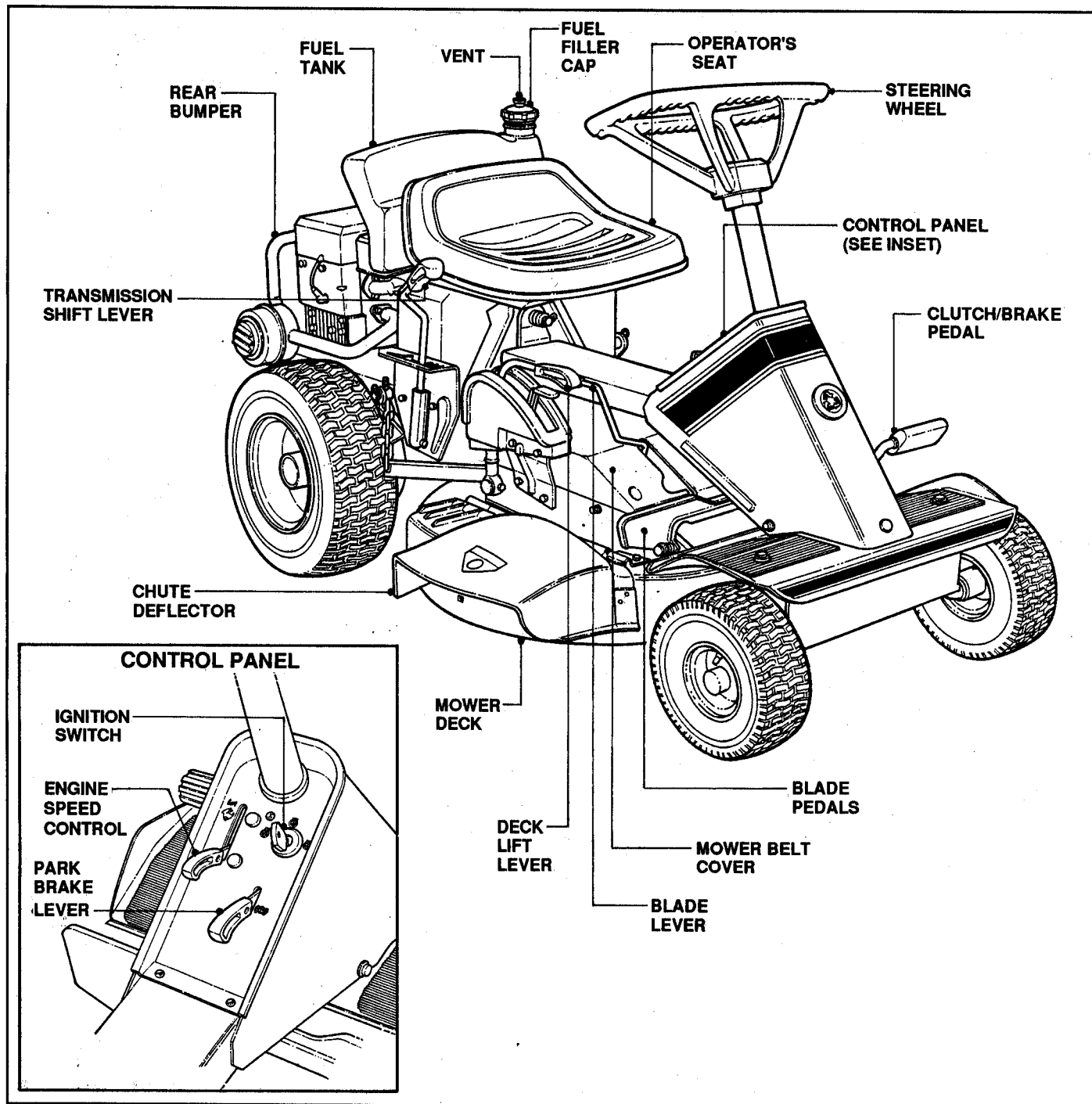

FIGURE 1.1

1.1 INTRODUCTION

This manual has been prepared for the operators of the SNAPPER Series 14 REAR ENGINE RIDER. Its purpose, aside from recommending standard operating procedures and routine service requirements, is to promote safety through the use of accepted operating practices. **Read, Understand and Follow** the **IMPORTANT SAFETY INSTRUCTIONS** on page 2 of this manual and all safety messages on the Rear Engine Rider and its attachments before operating.

1.2 NOMENCLATURE

The nomenclature drawing above, Figure 1.1, shows the essential parts of the SNAPPER Series 14 Rear Engine Rider. It is recommended that all operators of this equipment become thoroughly familiar with the controls, components and operation of this machine before operating. Specific details involving the engine are found in the separate engine owner's manual. **Study these manuals before operating and keep both handy for future reference.**

Section II- OPERATING INSTRUCTIONS

2.1 PRE-START CHECK LIST

Make the following checks and perform the service required before each startup.

- A. Check tires and add air as needed to bring pressure to 15 psi in front and 10 psi in rear tires.
- B. Check guards, deflectors and covers to make sure all are in place and securely tightened.
- C. Check engine oil and add oil as needed to bring level up to the full mark. Refer to engine owner's manual for oil specifications. See Figure 2.1.

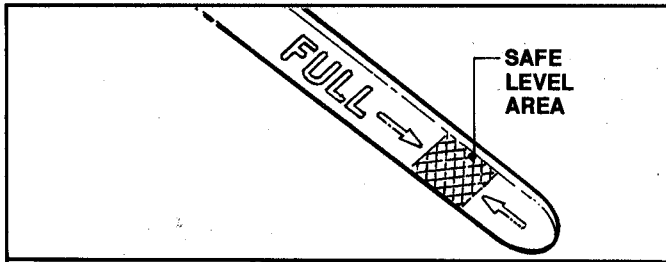

FIGURE 2.1

- D. Adjust seat as needed to most comfortable position. See Figure 2.3.
- E. Check blade control to insure it works freely. If blade pedals are depressed, blade lever can be moved manually from "ON" to "OFF" to stop blade.

CAUTION

The blade control lever must snap from "ON" to "OFF" when blade pedals are released. If blade control lever does not snap back, check mower belt tension. See 4.2 A. MOWER DRIVE BELT ADJUSTMENT.

- F. Clean exterior surfaces of cutting deck and engine of any accumulation of dirt, grass, oil etc. Keep engine air intake screen and cooling fins clear at all times.
- G. Add fuel to tank after pushing the Rear Engine Rider outside where fumes can dissipate. Make sure fuel cap is tight, vent is open and fuel valve is "ON" after refueling. Refer to engine owner's manual for fuel specifications. See Figure 2.2.

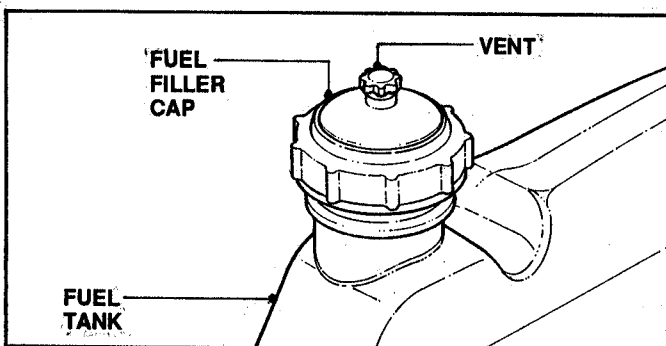

FIGURE 2.2

2.2 OPERATOR'S SEAT ADJUSTMENT

A. FRONT TO REAR ADJUSTMENT

- 1. With the engine stopped, loosen the two hand knobs and move seat to desired position. After adjustment, tighten knobs securely. See Figure 2.3.

NOTE

8hp models incorporate 4 hex head patch lock screws to mount the seat and will require a 1/2" SAE wrench for seat adjustment.

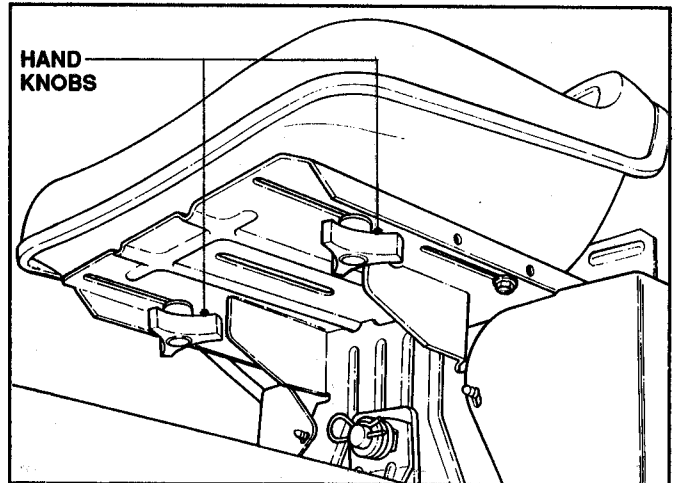

FIGURE 2.3

NOTE

If seat does not move after loosening knobs, it may be necessary to loosen the two hex head bolts at the rear of the seat bracket. Refer to Figure 2.3.

2.3 STOPPING

A. ENGINE

- 1. Stop engine by turning key to the "OFF" position. See Figure 2.4.

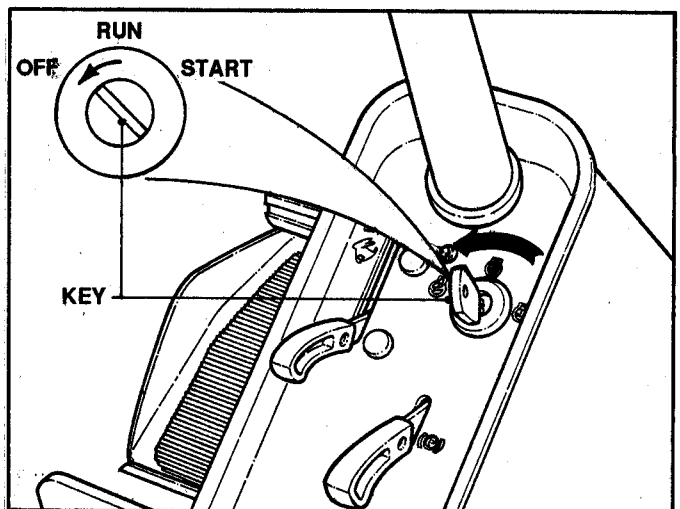

FIGURE 2.4

Section II- OPERATING INSTRUCTIONS



CAUTION



Before leaving the Rear Engine Rider with the engine running, stop the blade, shift to neutral and engage the park brake

B. WHEEL DRIVE

Stop motion of Rear Engine Rider by pushing clutch/brake pedal all the way "DOWN" to apply brake. See Figure 2.5.

NOTE

Depressing the clutch/brake pedal half way down activates the clutch to allow transmission shifting.

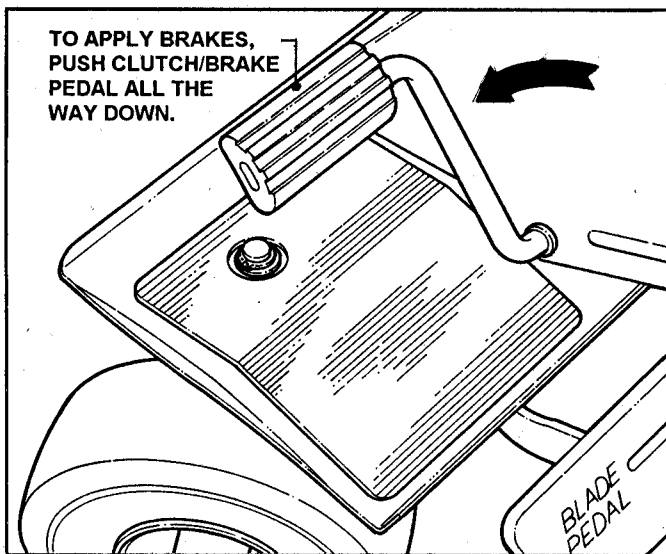

FIGURE 2.5

C. MOWER BLADE

Stop mower blade by removing feet from blade pedals or moving blade lever to the left and back to "OFF". See Figure 2.6.

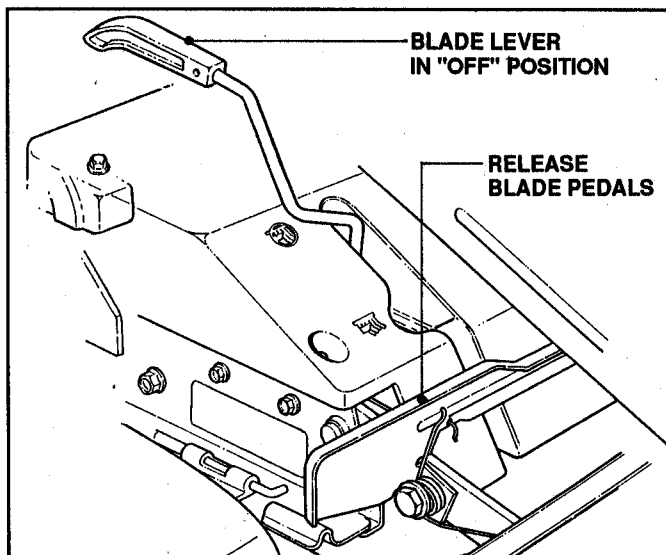

FIGURE 2.6

NOTE

Once blade is disengaged, it should come to a complete stop in 3 seconds or less. If the blade continues to rotate after 3 seconds, the blade brake should be adjusted. See 4.2, B. BLADE BRAKE ADJUSTMENT, for adjustment procedures or return machine to dealer for adjustment. DO NOT CONTINUE to operate mower until blade brake is properly adjusted.

D. PARK BRAKE

1. Engage park brake by pushing clutch/brake pedal "DOWN" and moving the park brake lever to the "ON" position. While holding the park brake lever "ON", release the clutch/brake pedal to set park brake. See Figure 2.7.

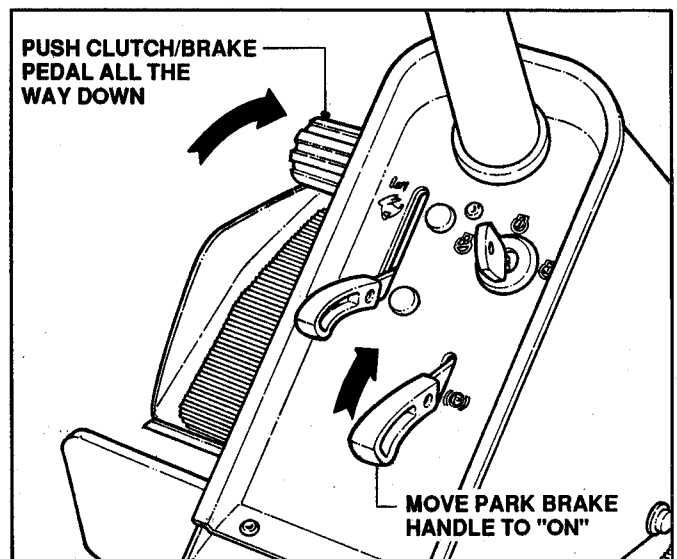

FIGURE 2.7

2. Release park brake by pushing down on clutch/brake pedal to release park brake lever.

2.4 STARTING & OPERATION

A. ENGINE (ELECTRIC START)

The 8hp electric start engines are not equipped with an interlock module, only interlock switches. When the ignition key is turned to "START", the engine will not turn over if ALL the interlock switches are not engaged! The 8hp recoil start and the 9hp, 10hp, 12hp, 13hp and 14hp electric start engines are equipped with an interlock system module. These engines will turn over when the ignition key is turned to "START", but the engine will not run if ALL interlock switches are not engaged.

B. OPERATION

Be seated on the Rear Engine Rider before attempting to start the engine with the key switch.

1. Make certain the blade lever is in the "OFF" position.

Section II- OPERATING INSTRUCTIONS

2. Push clutch/brake pedal all the way down and apply the park brake by lifting the park brake lever to the "ON" position. While holding park brake lever "ON" release clutch/brake pedal to set park brake. Refer to Figure 2.7.
3. Move the transmission shift lever to the neutral (N) position. See Figure 2.8.

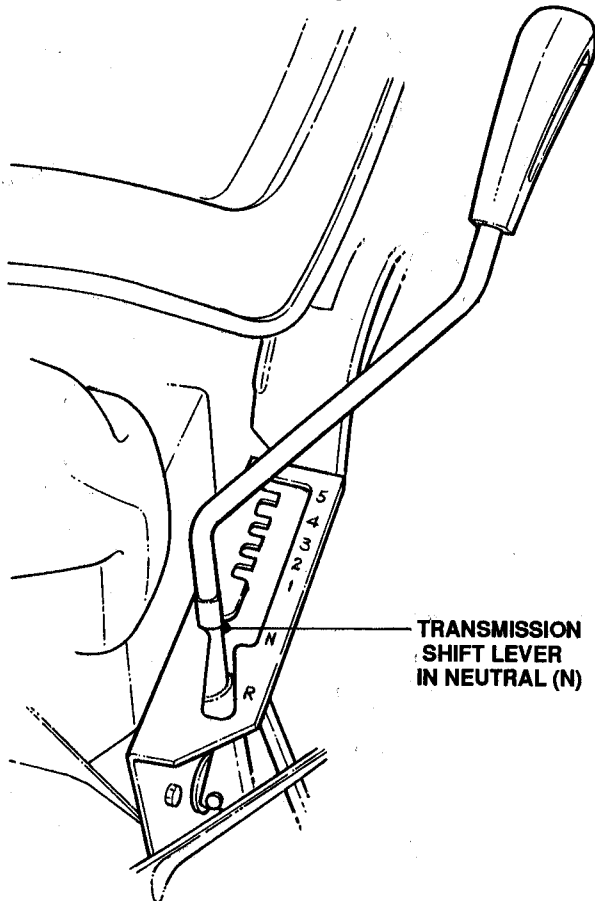

FIGURE 2.8

4. Open vent on fuel filler cap. See Figure 2.9.

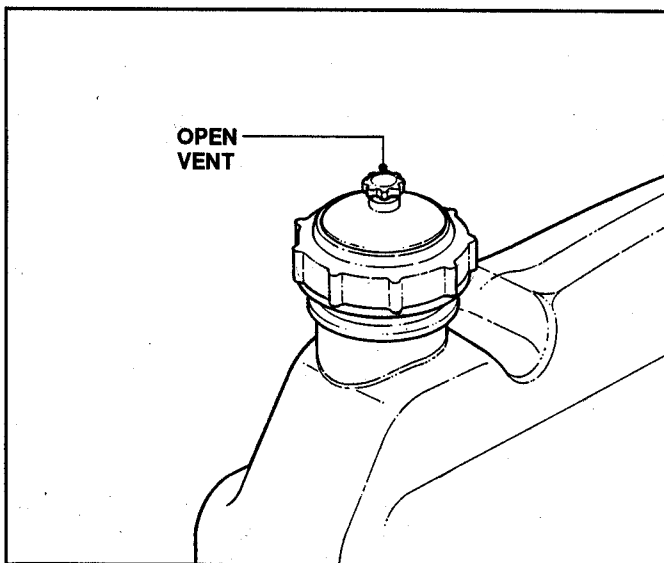

FIGURE 2.9

NOTE

Failure to open vent on the fuel filler cap or turn will cause engine to stall.

5. Move engine speed control to the choke position to start a cold engine. See Figure 2.10.

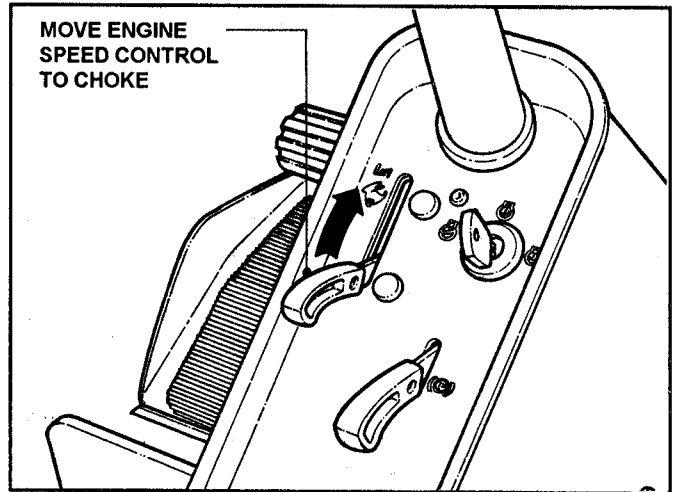

FIGURE 2.10

6. Turn key to the "START" position until engine starts. See Figure 2.11.

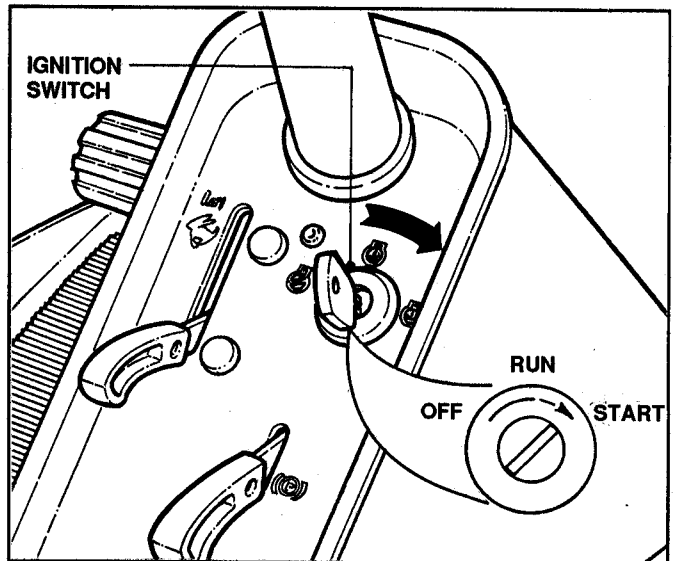

FIGURE 2.11

NOTE

If after 5 seconds of cranking the engine does not start, release the key and attempt starting again after 30 seconds.

7. After engine starts, allow a brief warmup until engine runs smooth.
8. Should the battery be too weak to start the engine, use the following instructions to manually start the 9hp, 10hp, 12hp, 13hp, and 14hp engines. Units with 8hp engines will require charging of the battery. See 4.6, D. CHARGING BATTERY.

Section II- OPERATING INSTRUCTIONS

NOTE

The engine on the Rear Engine Rider is equipped with a flywheel alternator to maintain battery charge when engine is run frequently.

C. ENGINE (MANUAL START)

1. Follow steps 1 through 5 in A. ENGINE (ELECTRIC START).
2. Turn key to "RUN" position. Refer to Figure 2.11.
3. Pull starter rope with a smooth, even motion until engine starts. Always guide the starter rope back into the recoil housing. Never allow rope to snap back. After engine starts, move engine speed control to the "FAST" position.
4. Allow a brief warmup until engine runs smoothly.

D. MOWER BLADE

1. With engine running, move engine speed control to the "FAST" position.
2. Raise and move blade lever to "ON" position and depress blade pedals. See Figure 2.12.

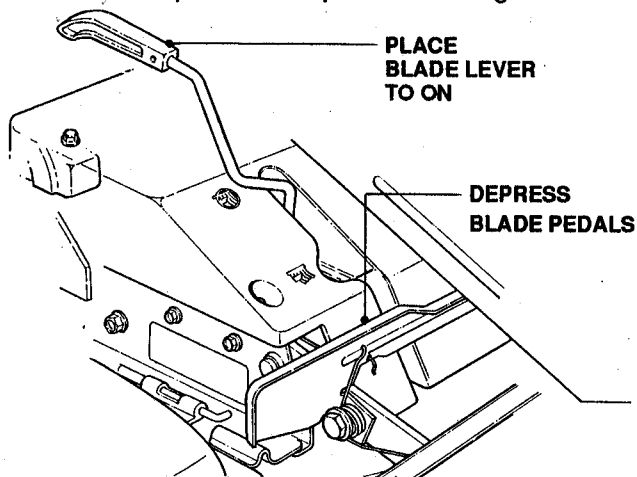

FIGURE 2.12

E. CUTTING HEIGHT ADJUSTMENT

1. Adjust cutting height as desired to any one of six positions using deck lift lever. See Figure 2.13.

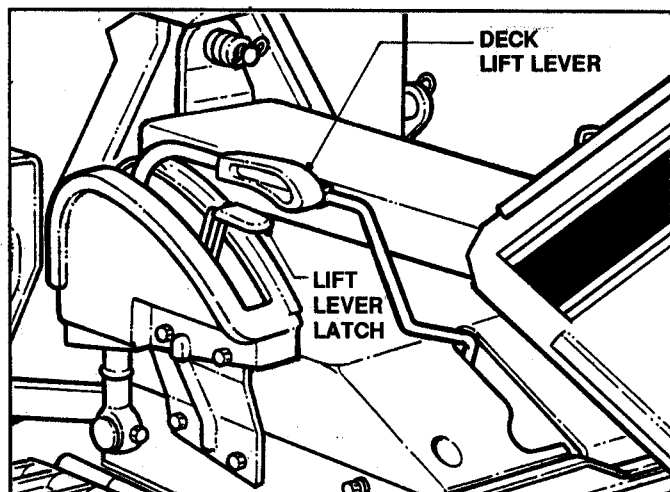

FIGURE 2.13

F. WHEEL DRIVE

1. With engine running, adjust engine speed control to desired position.
2. Depress clutch/brake pedal.
3. Place transmission shift lever in first forward speed.
4. Release clutch/brake pedal to start forward motion.
5. During forward motion, the transmission shift lever may be placed in any desired forward speed without depressing the clutch/brake pedal.

NOTE

For best cutting results, move the transmission shift lever into a slow forward speed and the engine speed control to a fast position. This combination will allow the mower blades to lift the grass while cutting smoothly and evenly.

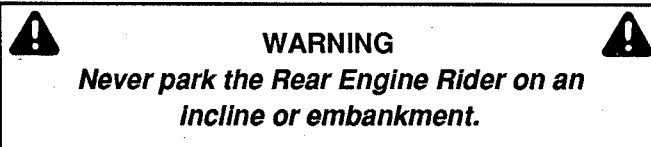

Section III- MAINTENANCE

3.1 INTRODUCTION

To retain the quality of the Rear Engine Rider, use genuine SNAPPER replacement parts only. Contact a local SNAPPER dealer for parts and service assistance. For the correct part or information for a particular Rear Engine Riding Mower, always mention the model and serial number. SNAPPER recommends returning the Rear Engine Rider to an authorized SNAPPER dealer annually for inspection and addition of any new devices which might upgrade the safety of the Rear Engine Rider.

For the nearest SNAPPER dealer, check the yellow pages under the heading LAWN MOWERS. For engine parts and service, look for the engine manufacturer's dealers under the heading ENGINES-gasoline.

3.2 SERVICE- AFTER FIRST 5 HOURS

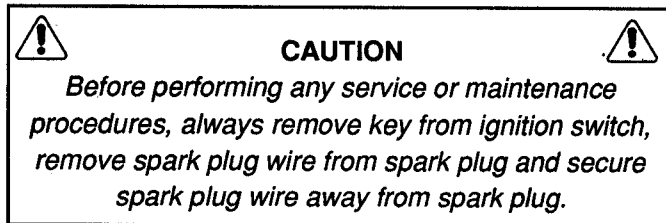

A. CHANGE ENGINE OIL

1. Change engine oil as follows:

- Place bricks or wooden blocks under front wheels to lower rear of engine.
- Loosen or remove oil fill cap on engine.
- Loosen oil drain plug.
- Place a 2 quart capacity container under the end of the oil drain. Open oil drain. See figure 3.1 for oil drains used on the Series 14 Rear Engine Riders.

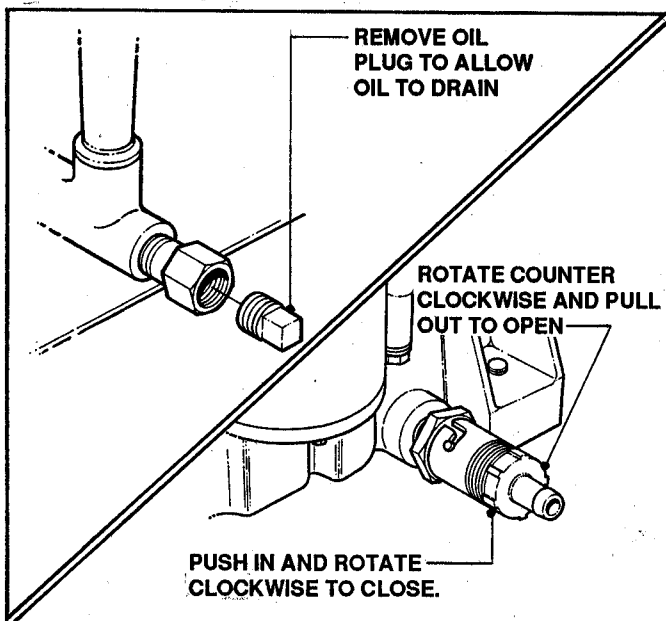

FIGURE 3.1

(e) After all oil has drained, close the drain.

Refer to Figure 3.1, and wipe up any oil that may have spilled.

(f) Fill engine crankcase with new oil. Refer to engine owner's manual for oil specifications.

(g) Change oil filter on 14hp engines at every oil change. Refer to engine owner's manual for service instructions.

B. CHECK MOWER BLADE

- Close vent on fuel filler cap.
- Apply park brake.
- Carefully stand Rear Engine Rider on rear bumper. It may be necessary to have help.

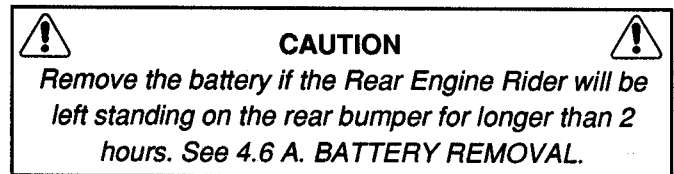

- Check torque of blade mounting bolts. As necessary torque to 45-55 ft. lbs. See Figure 3.2.

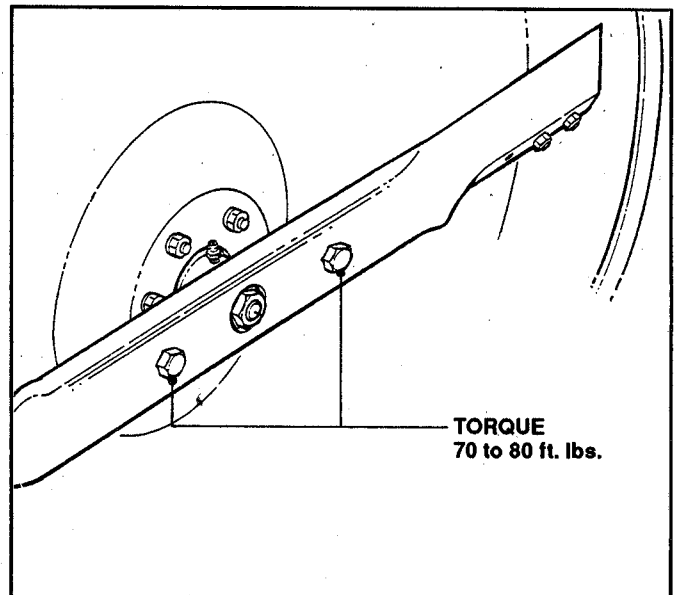
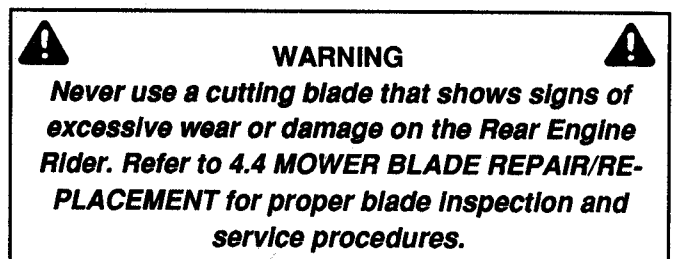

FIGURE 3.2

- Check blade for sharpness, wear and damage. See 4.4, A. BLADE WEAR LIMITS.

- Check blades for straightness. Refer to 4.2, C. ADJUSTING MOWER BLADES, steps 1 through 10.



Section III- MAINTENANCE

C. CHECK MOWER DRIVE BELT

1. Drive Belt Cover Removal

- (a) Lower deck to lowest setting.
- (b) Remove four self-tapping screws, two on each side of mower drive belt cover. See Figure 3.3.

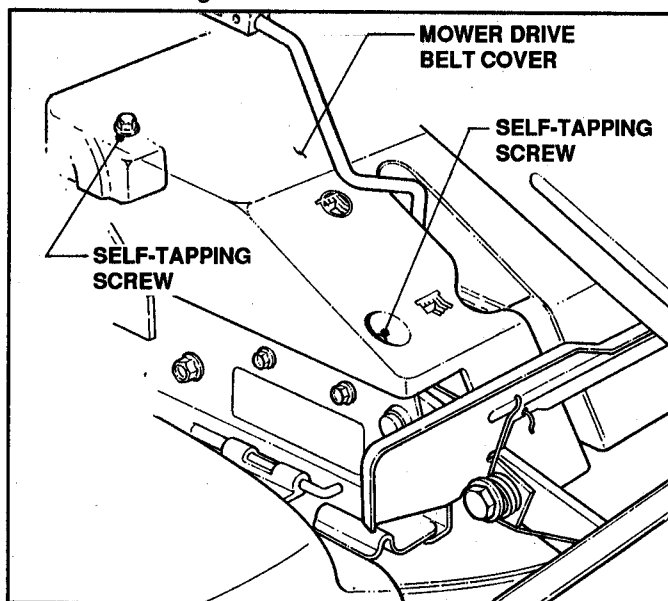

FIGURE 3.3

- (c) Slide cover back and rotate out on left side of mower deck.

3. Checking Belt Tension

- (a) Move blade lever up and over to the "ON" position and depress blade pedals. See Figure 3.4.

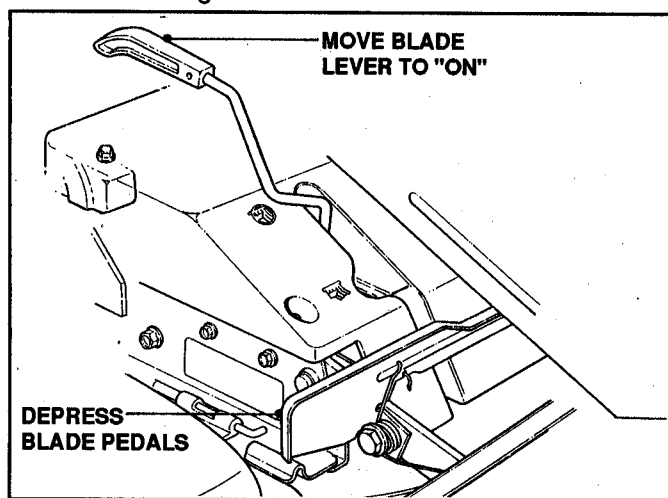

FIGURE 3.4

- (b) Measure the distance between belt at idler pulley. See Figure 3.5. The distance between belt should be 1-1/4" but no less than 1".

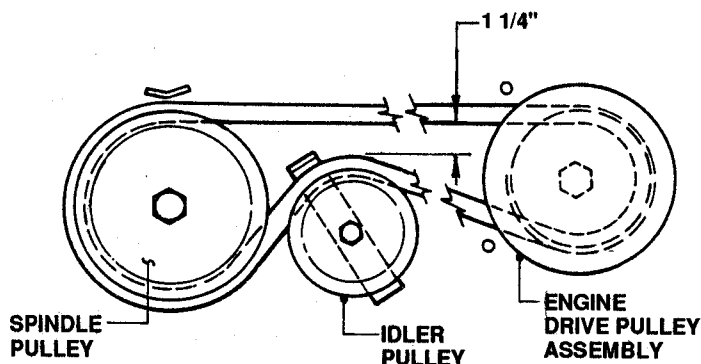

FIGURE 3.5

- (c) If the measurement is less than 1" the belt tension should be adjusted. See 4.2, A. MOWER DRIVE BELT ADJUSTMENT.

3.3 AFTER EVERY 25 OPERATING HOURS

A. ENGINE

1. Engine Oil

Change engine oil. Refer to 3.2, A. CHANGE ENGINE OIL. Refer to engine owner's manual for oil specifications.

2. Air Filter

Refer to engine owner's manual for service instructions.

B. MOWER COMPONENTS

1. Mower Drive Belt

Check belt for proper tension. Refer to 3.2, C. CHECK MOWER DRIVE BELT.

2. Mower Blade

Check blade for sharpness, wear, damage and torque. See 4.4 MOWER BLADE REPAIR/REPLACEMENT.

3. Mower Deck Level

Check mower deck for proper level. Adjust as required. See 4.2, D MOWER DECK ADJUSTMENT-LEVEL.

4. Cleaning Mower Deck

- (a) Remove key from ignition switch.
- (b) Remove spark plug wire and secure away from spark plug.
- (c) Close vent on fuel filler cap.
- (d) Carefully stand Rear Engine Rider on rear bumper.
- (e) Clean underside of mower deck, removing all accumulation of grass clippings and debris.
- (f) Lower Rear Engine Rider to ground and clean top of deck removing all grass clippings and debris.

Section III- MAINTENANCE

5. Mower Blade Spindle- Lubrication

With Rear Engine Rider standing on rear bumper, lubricate spindle with one shot of GP grease from grease gun. See Figure 3.6.

NOTE

If the Rear Engine Rider will be on its rear bumper for longer than two hours, remove the battery. See 4.6, A. BATTERY REMOVAL.

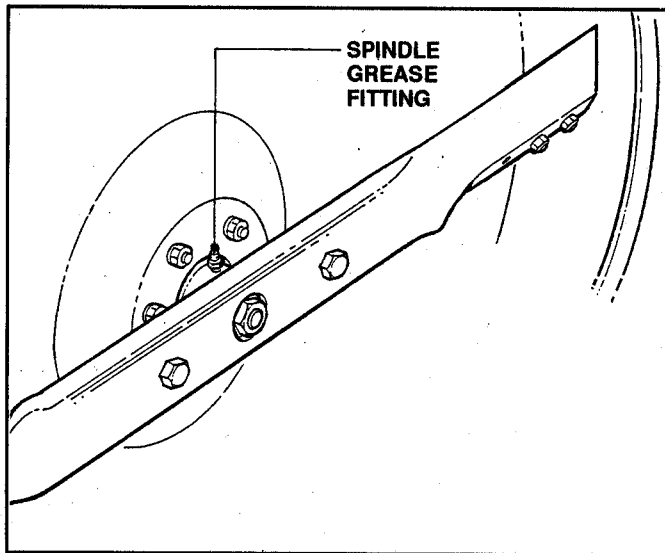

FIGURE 3.6

6. Mower Deck Linkage- Lubrication

Lubricate all mower deck linkage pivot points with a light coat of 30 wt. motor oil.

C. REAR ENGINE RIDER- LUBRICATION

1. Front Wheel Bearings

With Rear Engine Rider standing on its rear bumper, lubricate front wheel bearings with five shots of GP grease from grease gun. See Figure 3.7.

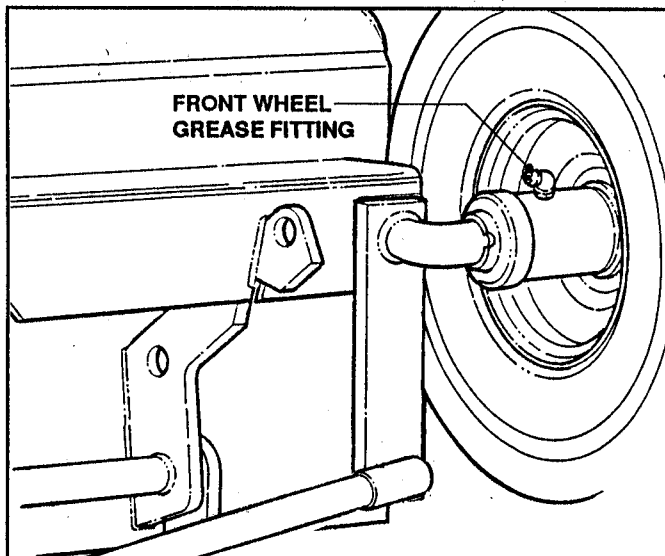

FIGURE 3.7

2. Left Rear Axle Bearing

On Rear Engine Riders powered by 13hp and 14hp engines, the left rear axle does not require lubrication.

However those powered by 8hp, 9hp, 10hp, or 12hp engines, the left rear axle bearing requires 3 shots of GP grease from a grease gun. See Figure 3.8.

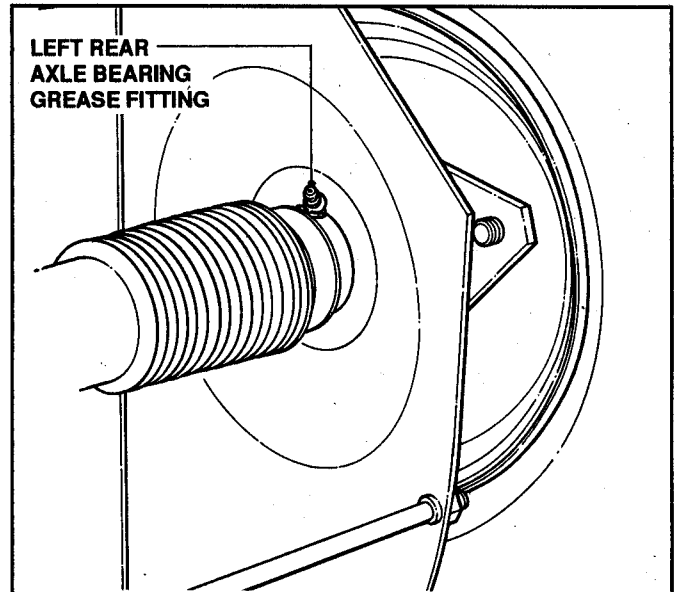

FIGURE 3.8

3. Right Rear Axle Bearing

The right rear axle bearing is lubricated by the differential lubricant.

4. Differential

(a) Check the fill plug and level plug for cracks and wear. Replace plug if signs of wear or cracks are visible.

NOTE

The SNAPPER Rear Engine Rider is shipped with additional check/fill plugs. Should more be required, contact an authorized SNAPPER dealer and order the desired quantity of plugs, part number 1-1024.

(b) To check lubricant, remove fill plug and visually inspect for lubricant on the internal parts of the differential. If no lubricant is visible on the internal parts of the differential. Contact a SNAPPER dealer for service. See Figure 3.9.

NOTE

Overfilling of the differential with lubricant will cause lubricant to leak onto drive components of the Rear Engine Rider.

Section III- MAINTENANCE

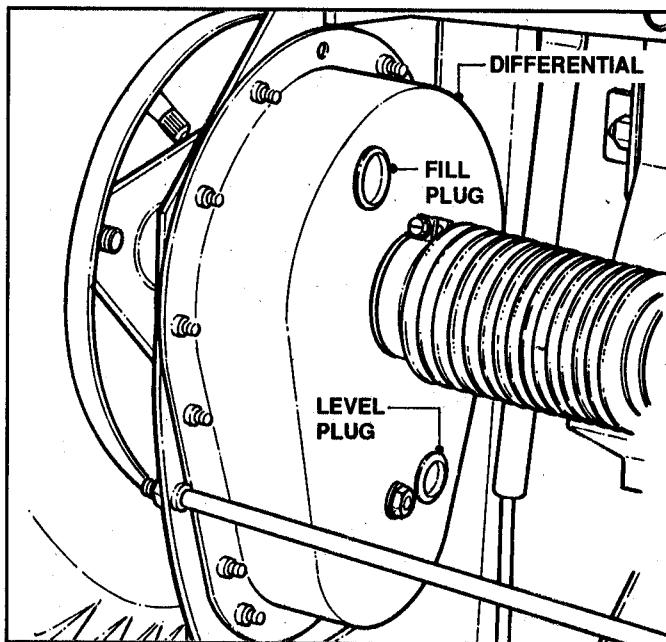

FIGURE 3.9

5. Chain Case

- (a) Check fill/level plug for damage. If signs of wear or cracks are visible, replace plug with new plug, part number 1-1024. See Figure 3.10.
- (b) To check lubricant in chain case, remove check/fill plug and look for lubricant on the internal components of the chain case. If no lubricant is visible, contact a SNAPPER dealer for service. See Figure 3.10.

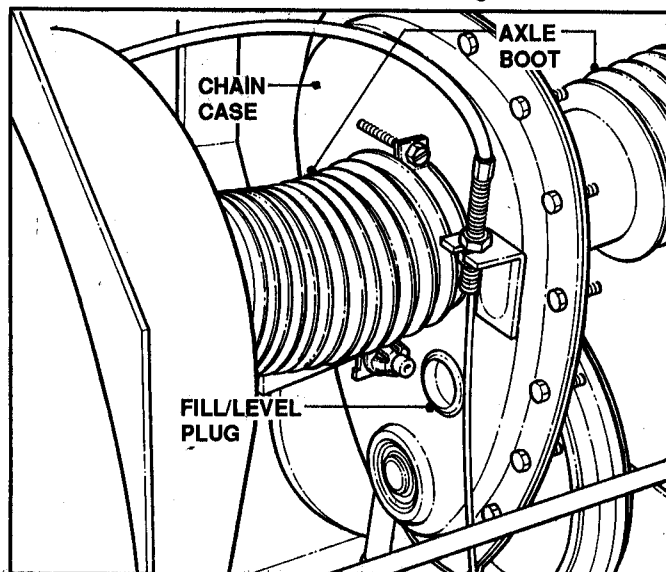

FIGURE 3.10

6. Axle Boots

Check axle boots for signs of wear or cracks. If cracks or wear is visible contact a SNAPPER dealer for service. Refer to Figure 3.10.

3.4 ANNUALLY (END OF EACH SEASON)

Perform all maintenance as described in 3.3 AFTER EVERY 25 OPERATING HOURS.

A. ENGINE

1. Service engine according to engine owner's manual.

B. FUEL FILTER

Service fuel filter as instructed below.

NOTE

To stop flow of fuel, tank may be removed from bracket and set on the floor so the fuel level will be below the filter.

1. Remove hose clamps from fuel filter.
2. Remove fuel lines from filter. Discard filter.
3. Install new fuel filter. Part number 1-4359. See Figure 3.11.
4. Reinstall fuel tank into bracket.

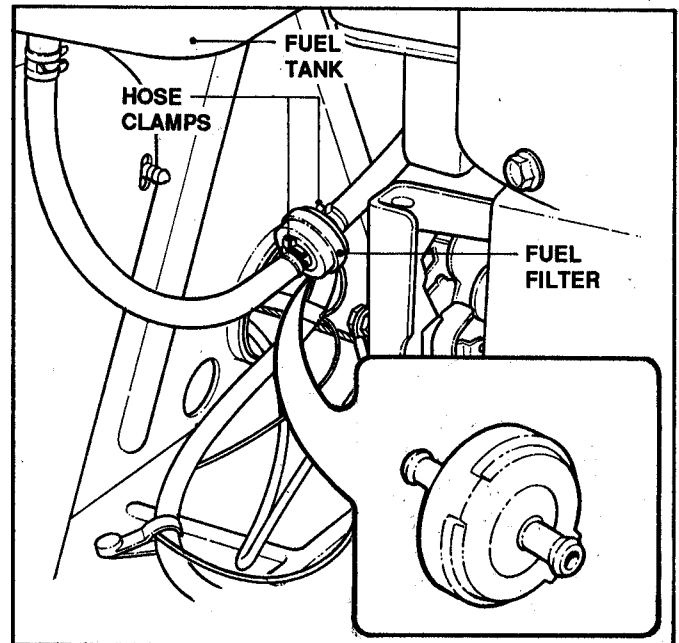

FIGURE 3.11

C. MOWER DECK

1. Clean all grass clippings and debris from deck.
2. Perform maintenance and lubrication as described in 3.3 AFTER EVERY 25 OPERATING HOURS.

3.5 EVERY TWO YEARS

In addition to regular maintenance, the following components of the Rear Engine Rider should be carefully inspected every two years for wear or damage. Replace worn or damaged parts with genuine SNAPPER replacement parts available from an authorized SNAPPER dealer.

- A. All bushings and pivot areas.
- B. King pin/Axles.

Section III- MAINTENANCE

- C. Transmission shift lever and detent.
- D. Clutch disc.
- E. Yoke.
- F. Mower deck linkage and pivot areas.

3.6 STORAGE (OUT OF SEASON)

If desired, the Rear Engine Rider can be stored on the rear bumper. Perform the following procedures to insure the Rear Engine Rider will operate properly when taken out of storage.

- A. Thoroughly clean the Rear Engine Rider removing all grass clippings and debris.
- B. Perform maintenance and lubrication as described in 3.3 AFTER EVERY 25 OPERATING HOURS.
- C. Drain fuel from fuel tank.
- D. Start engine and allow it to run until engine runs out of fuel. This allows the carburetor and fuel system to remain clean during storage.
- E. Remove battery. See 4.6, D. BATTERY STORAGE.
- F. Close vent on fuel filler cap.
- G. Carefully stand Rear Engine Rider on rear bumper in desired location for storage.

Section IV- ADJUSTMENTS & REPAIR



CAUTION



Before performing any adjustments or repairs, remove key, remove spark plug wire from spark plug and secure spark plug wire away from spark plug.

4.1 ENGINE ADJUSTMENTS & REPAIR

Refer to the engine owner's manual for those adjustments and/or repairs that can be made by the owner.

4.2 MOWER DECK & COMPONENT ADJUSTMENTS

The following mower deck and component adjustments and repairs can be made by the owner. However, it is recommended that all adjustments and repairs be made by an authorized SNAPPER dealer.

A. MOWER DRIVE BELT ADJUSTMENT

1. Remove mower drive belt cover. Refer to 3.2, C. CHECK MOWER DRIVE BELT.
2. Move blade lever up and over to the "ON" position.
3. Measure the distance between belt at idler pulley. The distance should measure 1-1/4" but no less than 1". See Figure 4.1.

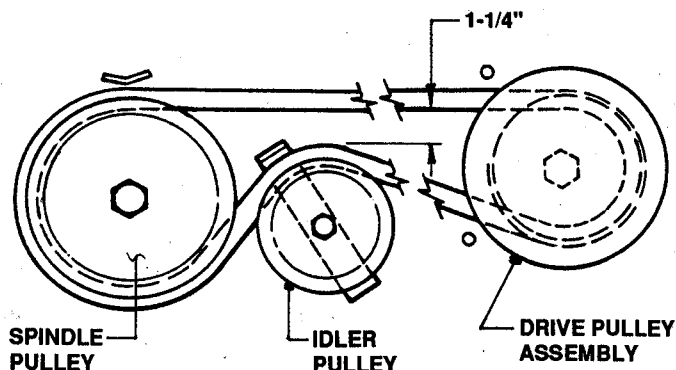

FIGURE 4.1

4. If the distance is less than 1", adjust belt tension as follows.

- (a) Remove hair pin and flat spacers from pivot stud. See Figure 4.2.
- (b) Pull front frame forward until distance between belt, with blade lever "ON", measures 1-1/4".

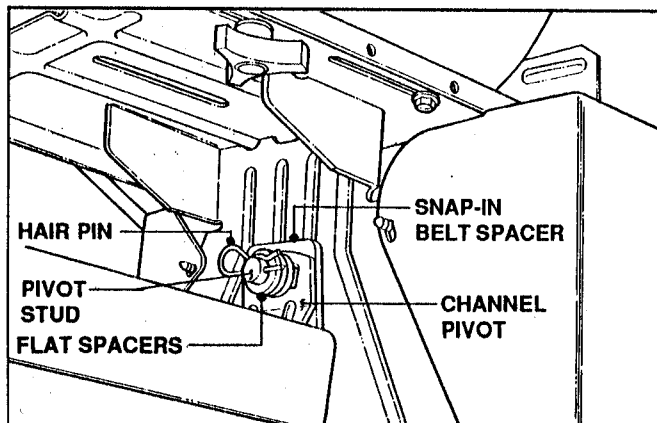

FIGURE 4.2

- (c) Install required number of snap-in belt spacers behind channel pivot until the 1-1/4" distance between belt is maintained. See Figure 4.3.

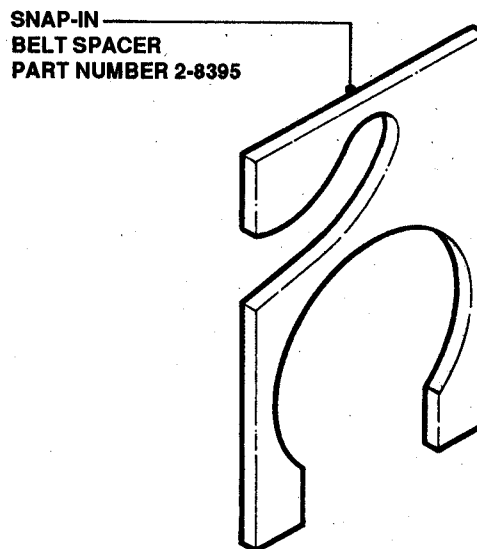

FIGURE 4.3

NOTE

The SNAPPER Series 14 Rear Engine Rider is shipped with additional spacers specifically designed for the Series 14 Rear Engine Rider. Should additional spacers be required, contact an authorized SNAPPER dealer and order the desired quantity of snap-in belt spacers, part number 2-8395.

- (d) Reinstall the required amount of flat spacers removed in step (a) and install hairpin. Refer to Figure 4.2. Retain any remaining spacers for readjustment when a new belt is installed.

Section IV- ADJUSTMENTS & REPAIR

B. BLADE BRAKE ADJUSTMENT— Early Series 14

WARNING
Do not remove the mower drive belt covers to perform testing of the blade brake.

1. Start engine. Move blade lever up and over to the "ON" position. Depress blade pedals.
2. Move engine speed control to "FAST".
3. Release blade pedals to disengage blade lever.
4. Time the stopping time of the blade by viewing belt behind mower drive belt cover. The belt should stop rotation in 3 seconds. If the belt continues rotation longer than 3 seconds, adjustment of the blade brake is required as follows, or contact an authorized SNAPPER dealer for service. DO NOT CONTINUE to operate the mower until the blade brake is properly adjusted.

CAUTION
Before attempting any adjustments or repairs, stop the engine, remove the key, remove the spark plug wire from spark plug, and secure spark plug wire away from spark plug.

- (a) Remove mower drive belt cover. Refer to 3.2, C. CHECK MOWER DRIVE BELT.
- (b) Move the blade lever up and over to the "ON" position.
- (c) Depress blade pedals to keep blade lever engaged.
- (d) Loosen jam nut on eye-bolt.
- (e) Turn the "T"-nut clockwise several complete turns. After adjustment, make certain the tab of the "T"-nut is on top of the anchor. See Figure 4.4.

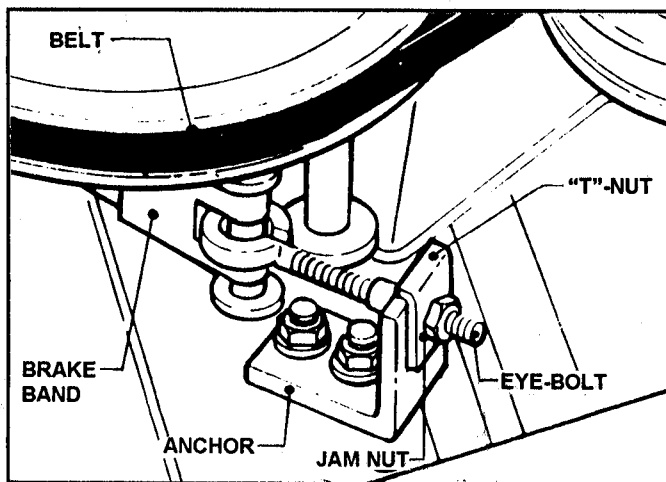

FIGURE 4.4

- (f) Release blade pedals allowing the blade lever to return to "OFF".
- (g) Depress blade pedal and measure the distance between front of blade lever and latch plate. The distance should be no greater than 1/4". See Figure 4.5.

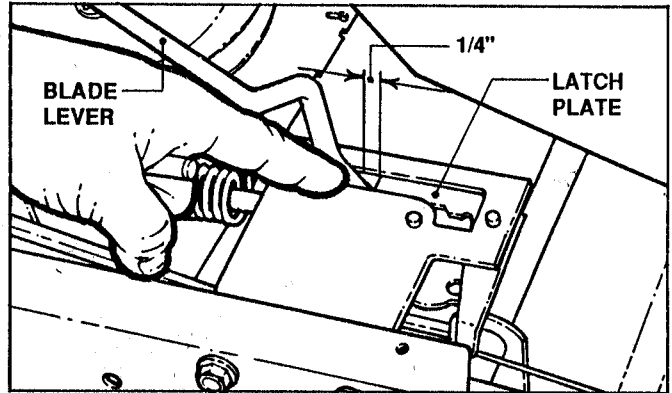

FIGURE 4.5

- (h) If measurement is greater than 1/4", continue adjustment by following steps (b) through (g).

WARNING
Never attempt to start engine with mower drive belt cover removed.

- (i) After adjustment of the blade brake is completed, tighten jam nut, replace mower drive belt cover, reconnect spark plug wire and recheck blade stopping time.

C. BLADE BRAKE ADJUSTMENT— Late Series 14

1. Follow procedures as described in B. BLADE BRAKE ADJUSTMENT— Early Series 14, steps 1 through 4, (c).
2. Remove cotter pin from eye-bolt swivel.
3. Rotate swivel clockwise several complete rotations. See Figure 4.6.

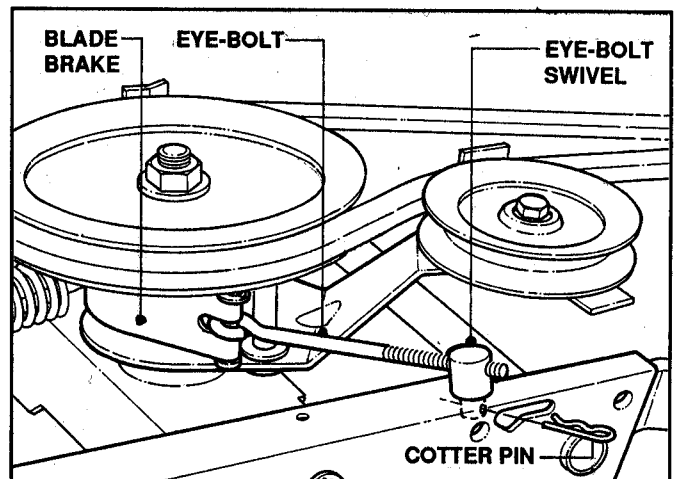

FIGURE 4.6

Section IV- ADJUSTMENTS & REPAIR

4. Reinstall swivel and cotter pin.
5. Depress blade pedals and measure the distance between front of blade lever and latch plate. The distance should be no greater than 1/4". See Figure 4.7.

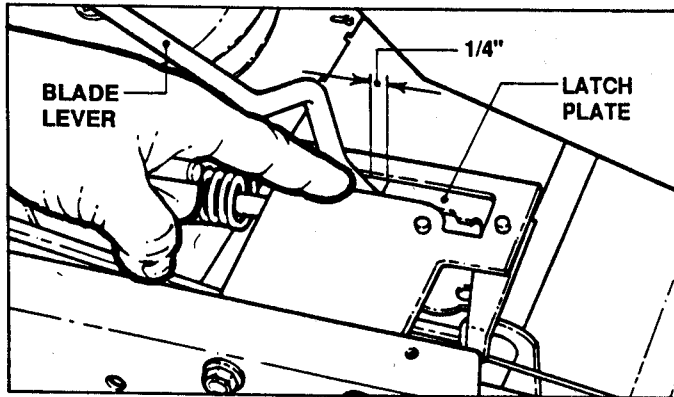

FIGURE 4.7

6. If the distance is greater than 1/4", repeat steps 2 and 3 until the 1/4" distance is achieved.
7. Reinstall belt cover, reconnect spark plug wire and recheck blade stopping time.

D. ADJUSTING MOWER BLADE

Follow procedures for standing Rear Engine Rider on rear bumper.

CAUTION

Before attempting any adjustments or repairs, stop the engine, remove the key, remove spark plug wire from spark plug, and secure spark plug wire away from spark plug.

NOTE

If the Rear Engine Rider will be on its rear bumper for longer than two hours, remove the battery.
See 4.6, A. BATTERY REMOVAL.

1. Select a point on the deck and mark for reference.
2. Mark blade tips as "A" and "B".
3. Rotate blade until blade tip "A" is at deck reference mark.
4. Measure the distance between deck lip and blade tip. Note the measurement. See Figure 4.8.

NOTE

On Hi-Vac decks the measurement between the blade tip and the deck lip should be 3/8"

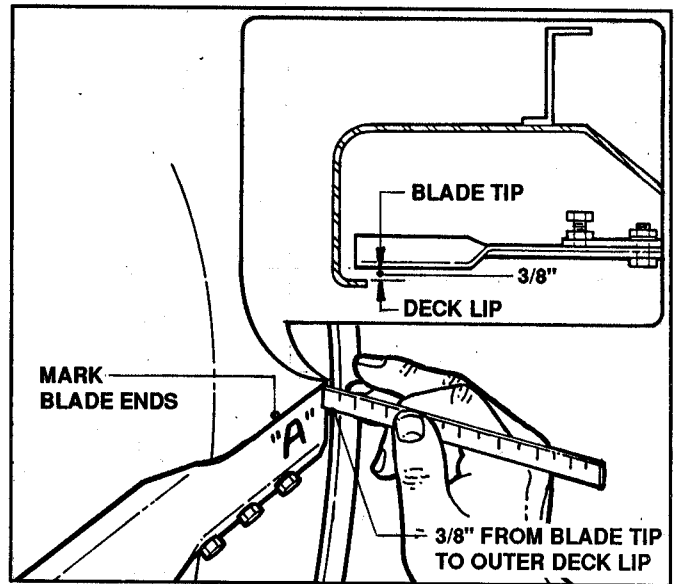

FIGURE 4.8

5. Repeat steps 3 and 4 with blade tip "B".
6. If measurement between blade tips and deck are different and there is more than 1/16" difference between blade tip measurements, adjust blade as follows:
 - (a) Loosen jam nuts on blade bar.
 - (b) Adjust jack screws "IN" or "OUT" until blade tip measurements are within 1/16" of each other and blade tips are 3/8" away from deck lip. See Figure 4.9.

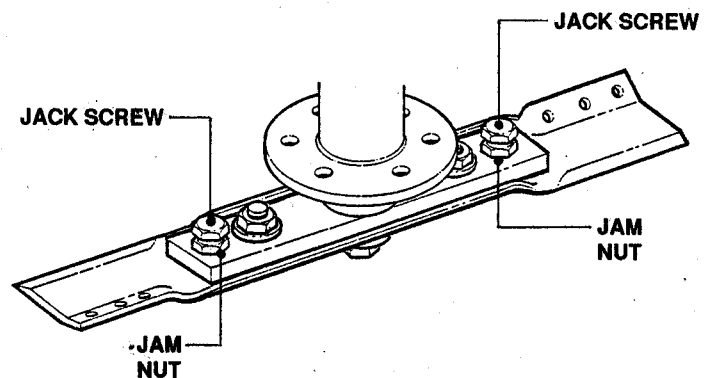

FIGURE 4.9

- (c) Tighten jam-nuts.

D. MOWER DECK ADJUSTMENT- LEVEL

1. Side-To-Side

Before making deck leveling adjustments, check the tire pressure. Front tires 15 psi, rear tires 10 psi. If tires are properly inflated and mowing is still uneven adjust side-to-side deck level as follows.

Section IV- ADJUSTMENTS & REPAIR

NOTE

SNAPPER Rear Engine Riders with 25" and 28" decks do not require side-to-side deck leveling.

- Place Rear Engine Rider on a smooth, level surface.
- Turn engine off and remove key, remove spark plug wire from spark plug and secure wire away from plug.
- Place a piece of angle iron under center of deck at the rear.
- Remove rear hanger chains and allow center, rear of deck to rest on angle iron.
- Measure the distance from blade tips to floor. If the measurement is within 1/8" from side to side the deck attitude is satisfactory. If difference from side to side is greater than 1/8", continue with adjustment.
- Loosen the shoulder bolt retaining the left side of blade pedals.
- Turn eccentric "UP" or "DOWN" as required until blade tips are within 1/8" of each other. See Figure 4.10.

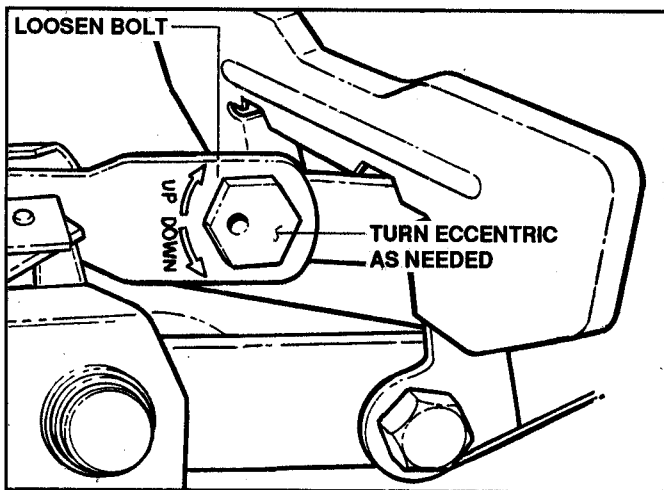

FIGURE 4.10

- Tighten shoulder bolt loosened in step (h).
- Readjust rear hanger chains to maintain level. Reinstall rear hanger chains. Refer to Figure 4.11.

2. Front to Rear Level

With the rear engine rider on a smooth, level surface, rotate blade until blade tips are at front and rear of deck. Measure the distance from blade tips to floor. The distance should be the same, or the rear 1/8" lower than the front. If the rear blade tip is higher or is more than 1/8" lower than the front, proceed with adjustment.

- Remove rear hanger chains.
- Turn each hanger pivot the same number of rotations on the eye-bolt to raise or lower the rear of the deck. See Figure 4.11.

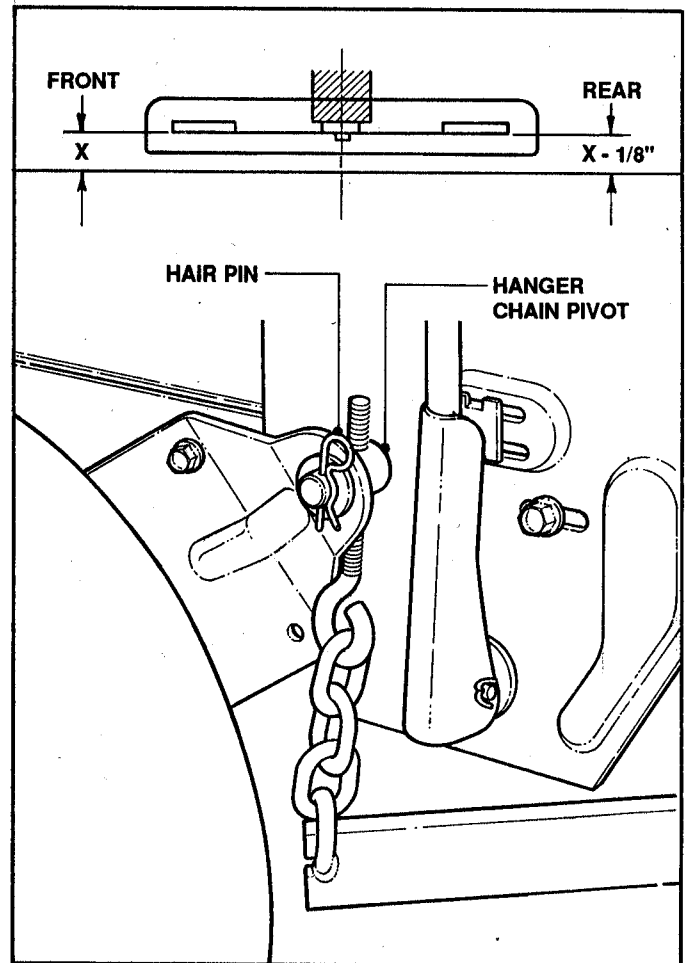

FIGURE 4.11

- Reinstall rear hanger chains and measure blade tips again.
- Repeat steps (a) through (c) until proper level is obtained.

E. MOWER DECK TIMING ROD ADJUSTMENT

The mower deck timing rod is pre-adjusted at the factory. It is set to maintain the deck in the same attitude through all heights of cut. If suspected the timing rod requires adjustment, contact an authorized SNAPPER dealer for service. See Figure 4.12.

Section IV- ADJUSTMENTS & REPAIR

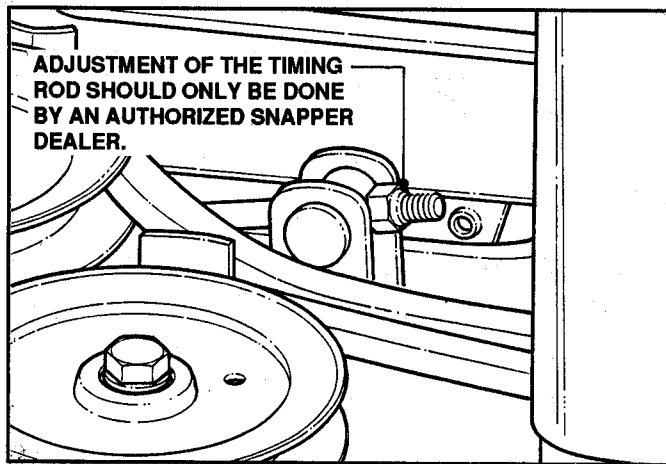
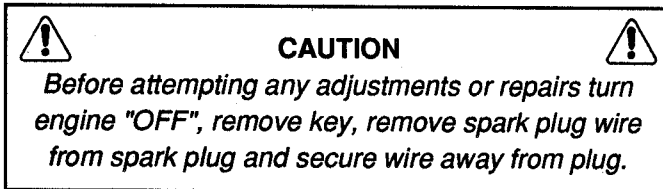

FIGURE 4.12

F. CUTTING HEIGHT ADJUSTMENT.

The deck cutting height may be adjusted to obtain desired cutting heights when using the deck lift lever.



1. Place the Rear Engine Rider on a smooth, level surface.
2. Move deck lift lever to the lowest cutting position.
3. Loosen the two lift quadrant mounting bolts. See Figure 4.12A.

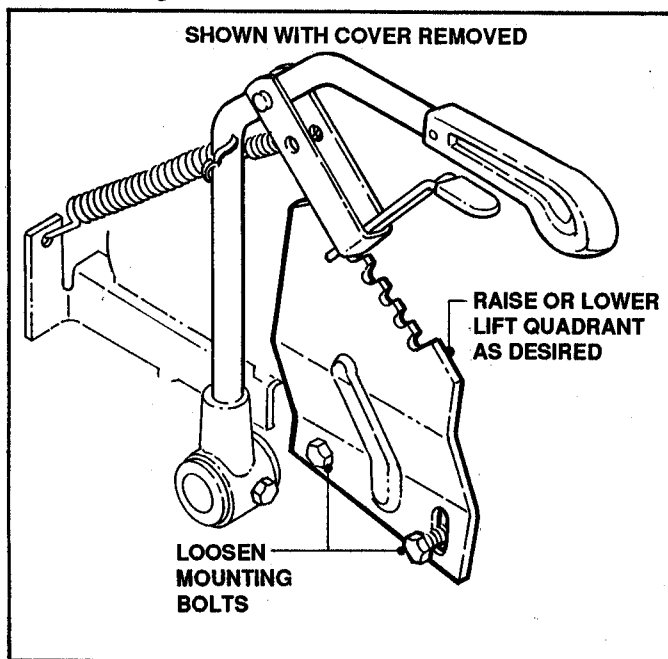

FIGURE 4.11A

4. Raise or lower lift quadrant to obtain desired cutting height.

NOTE

Lift quadrant in lowest position gives 1" to 3-1/2" cutting height. Lift quadrant in highest position gives 1-1/2" to 4" cutting height.

5. Tighten lift quadrant mounting bolts.

4.3 REAR ENGINE RIDER DRIVE COMPONENTS

The following drive components may be adjusted by the owner. However, it is recommended that all adjustments to the Rear Engine Rider be made by an authorized SNAPPER dealer.

A. CLUTCH- STARTING MOTION ADJUSTMENT

If the Rear Engine Rider clutch is too positive or slips excessively when the clutch/brake pedal is released, adjust as follows:

1. Remove key from ignition switch.
2. Remove spark plug wire from spark plug and secure wire away from plug.
3. Close vent on fuel filler cap.
4. Carefully stand Rear Engine Rider on rear bumper.
5. Locate yoke arm between chain case and differential.
6. Move spring to first hole (for positive clutch action) to 4th hole (to increase clutch slippage). See Figure 4.13.

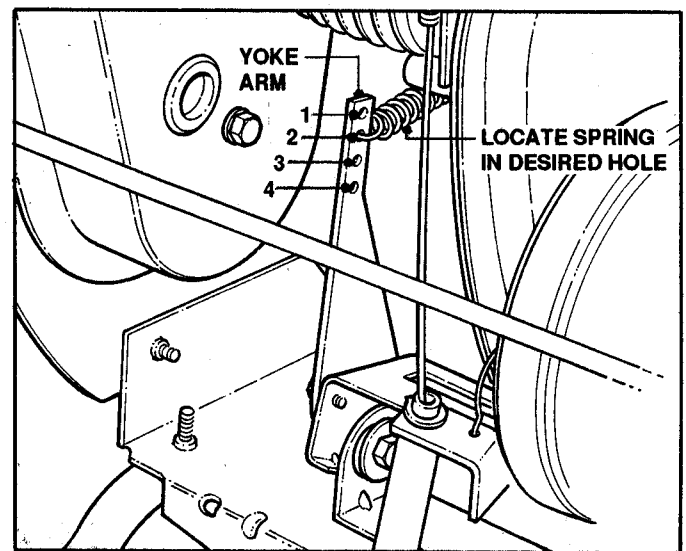

FIGURE 4.13

B. CLUTCH- SHIFTING ADJUSTMENT

Depress clutch/brake pedal, set park brake and move transmission shift lever into a forward speed. If shifting is difficult or will not shift, adjust the clearance between clutch disc and drive disc as follows:

Section IV- ADJUSTMENTS & REPAIR

1. Follow procedures for standing Rear Engine Rider on rear bumper.

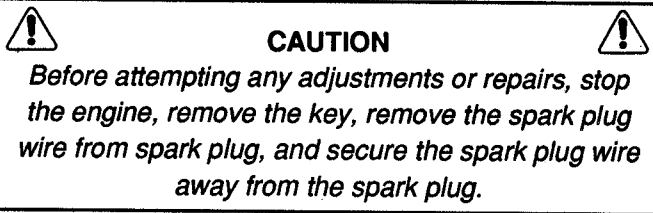

2. Depress clutch/brake pedal all the way down. Move and hold the park brake lever in the "ON" position then release clutch/brake pedal to engage the park brake.
3. Move the transmission shift lever to reverse.
4. Visually inspect to make certain there is clearance between clutch disc and drive disc. See Figure 4.14.

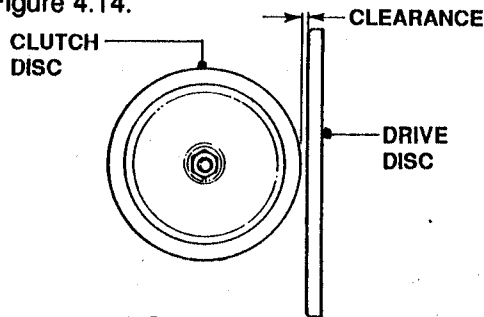

FIGURE 4.14

5. If no clearance is visible, release park brake by depressing clutch/brake pedal to release park brake lever.
6. Pull clutch/brake pedal towards operator's seat and slide one ferrule from cable through the eye in the clutch/brake pedal arm. See Figure 4.15.

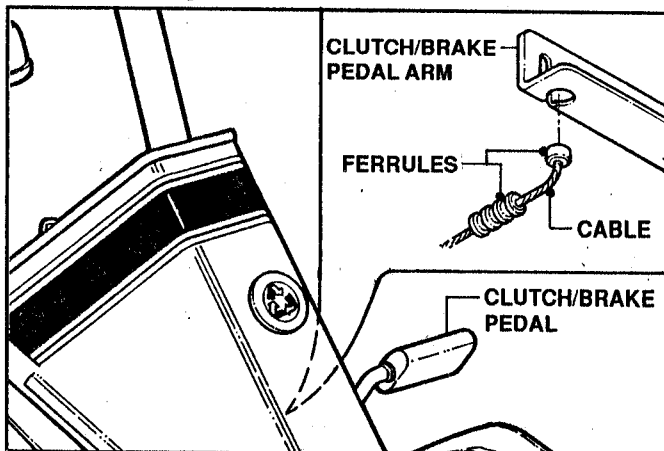

FIGURE 4.15

7. Engage park brake as described in step 2.
8. Check for clearance between clutch disc and driven disc. If no clearance is visible, repeat steps 5 and 6 until clearance is visible. Refer to Figures 4.14 and 4.15.

NOTE

If adjustment cannot be completed or made because all ferrules have been used, contact an authorized SNAPPER dealer for service.

C. WHEEL BRAKE ADJUSTMENT

Test the wheel brake on a dry concrete surface. When properly adjusted the Rear Engine Rider will stop within 3 feet from fastest speed. If stopping distance is more than 3 feet the wheel brake should be adjusted as follows.

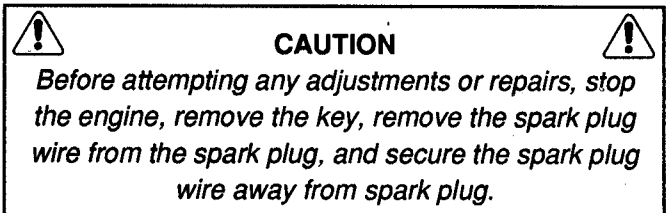

1. Follow procedures for standing Rear Engine Rider on rear bumper. Refer to 4.2, C. ADJUSTING MOWER BLADES.
2. Depress clutch/brake pedal all the way down. Move and hold the park brake lever in the "ON" position and release the clutch/brake pedal to engage park brake. See Figure 4.16.

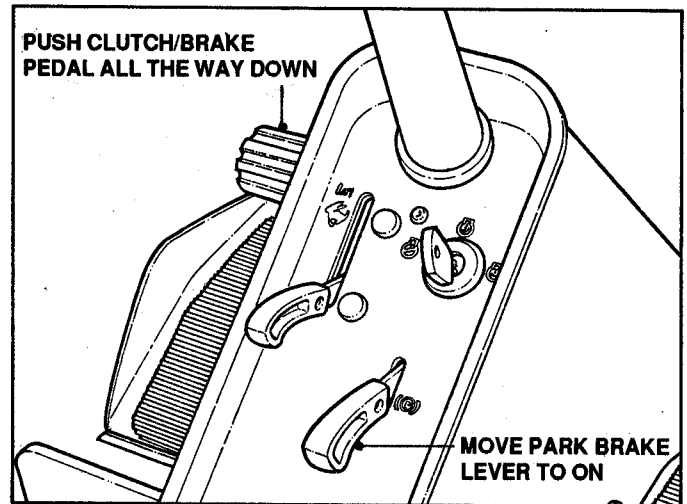

FIGURE 4.16

3. Measure the distance between end of clutch/brake cable and top of cotter pin. Measurement should be no less than 3/16" and no greater than 7/16". See Figure 4.17.

Section IV- ADJUSTMENTS & REPAIR

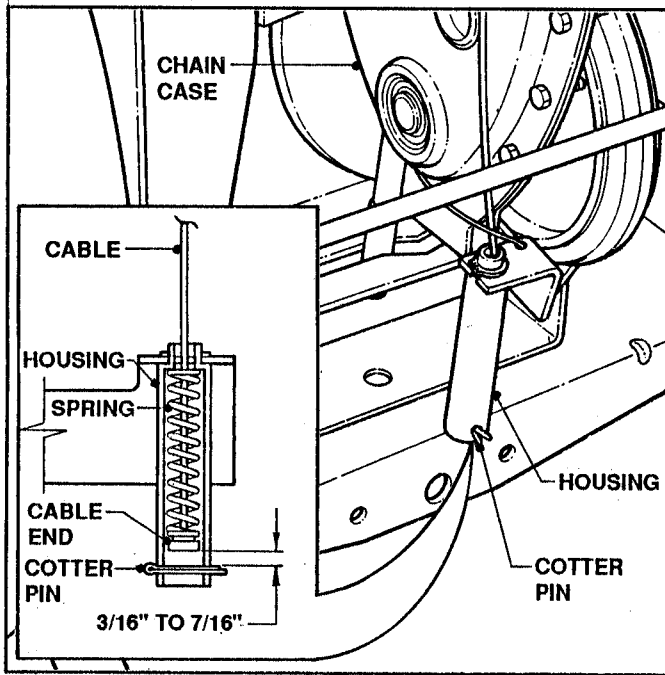

FIGURE 4.17

4. If measurement is less than $3/16$ " or greater than $7/16$ ", loosen the two jam nuts holding the clutch/brake cable to the chain case bracket. See Figure 4.18.

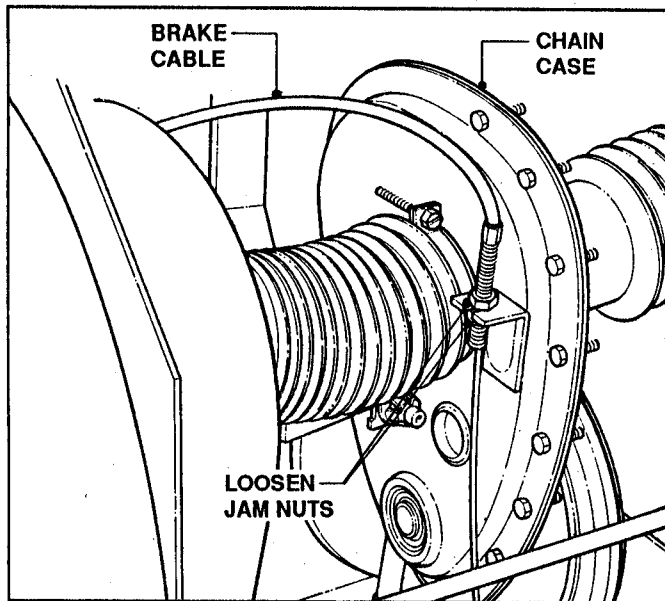

FIGURE 4.18

5. Adjust cable up or down using the jam nuts to obtain a distance of $5/16$ " between end of clutch/brake cable and top of cotter pin. Refer to Figure 4.17.
6. After adjustment is complete, securely tighten cable jam nuts.

4.4 MOWER BLADE REPAIR/REPLACEMENT

A. BLADE WEAR LIMITS

1. Inspect blade frequently for signs of excessive wear or damage. See Figure 4.19.

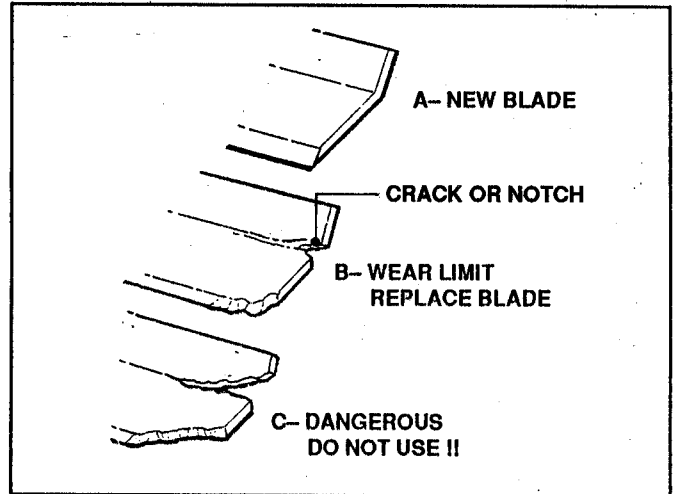

FIGURE 4.19

WARNING

Never use a cutting blade that shows signs of excessive wear or damage on the Rear Engine Rider. Refer to Figure 4.19.

B. BLADE SHARPENING

1. Follow procedures for standing Rear Engine Rider on rear bumper.

CAUTION

Before performing any service to blade, turn engine off, remove key, remove spark plug wire from spark plug, and secure spark plug wire away from spark plug.

2. Remove blade. See Figure 4.20.

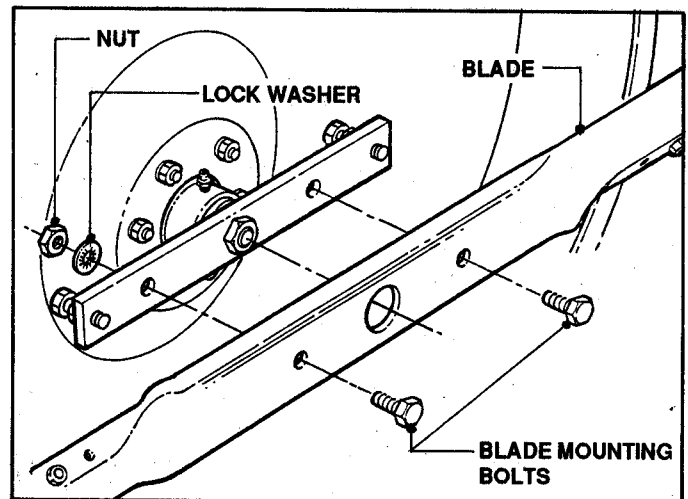

FIGURE 4.20

Section IV- ADJUSTMENTS & REPAIR

3. Inspect condition of blade. Refer to Figure 4.19.
4. If blade is in good condition, sharpen at 25° ($\pm 3^\circ$). Do not sharpen beyond existing cutting edge. See Figure 4.21.

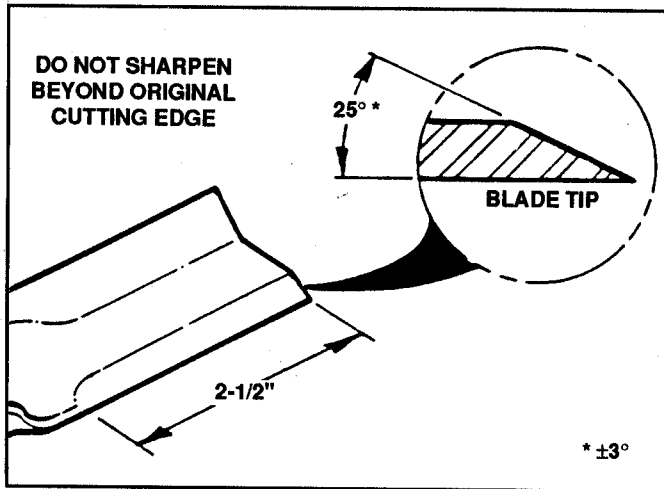

FIGURE 4.21

5. Check blade balance after sharpening. If necessary, correct blade balance by grinding the heavy end of blade.
6. Reinstall blade. Refer to Figure 4.20. Torque blade mounting bolts to 45-55 ft. lbs.

C. BLADE REPLACEMENT CHART

Deck Width	Blade Number	Air Lift Number	Air Lift Kit Number
25"	1-9518	3-7723	6-0480
28"	1-9515	3-7723	6-0480
30"	1-8069	3-1724	6-0735
33"	1-9523	3-7723	6-0480

CAUTION

On those Rear Engine Riders equipped with a grass catcher attachment, the air lifts should be replaced when the blade is replaced

4.5 MOWER DRIVE BELT REPLACEMENT

Inspect mower drive belt as described in 3.2, C. CHECK MOWER DRIVE BELT. Replace belt if signs of excessive wear and/or damage are present.

CAUTION

Before attempting any adjustments or repairs, stop the engine, remove the key, remove the spark plug wire from the spark plug and secure wire away from plug.

A. BELT REMOVAL

1. Remove mower drive belt cover. Refer to 3.2, C. CHECK MOWER DRIVE BELT.
2. Cut and remove old belt.

B. BELT REPLACEMENT

1. Remove idler. See Figure 4.22.

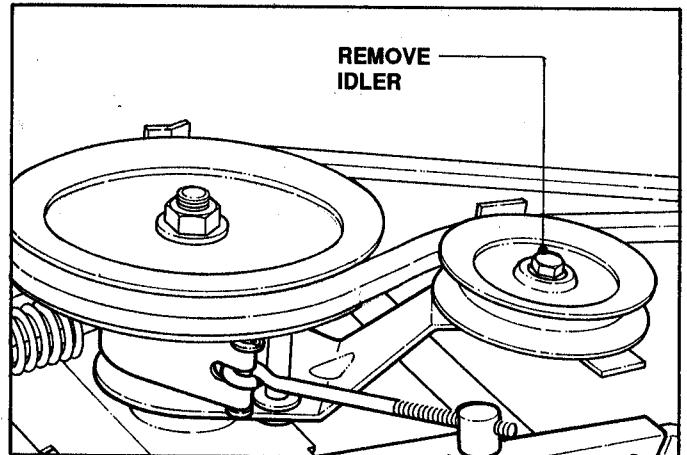

FIGURE 4.22

3. Move transmission shift lever to the neutral (N) position.
4. Follow procedures for standing the Rear Engine Rider on rear bumper. Refer to 4.2, C. ADJUSTING MOWER BLADE.
5. Route new belt, part number 2-2252, through front belt guide to engine pulley/drive disc assembly.
6. Rotate yoke out with your hand and work belt between drive and driven discs.
7. Move transmission shift lever to the #5 position and place belt over drive disc and into drive pulley belt groove. See Figure 4.23.

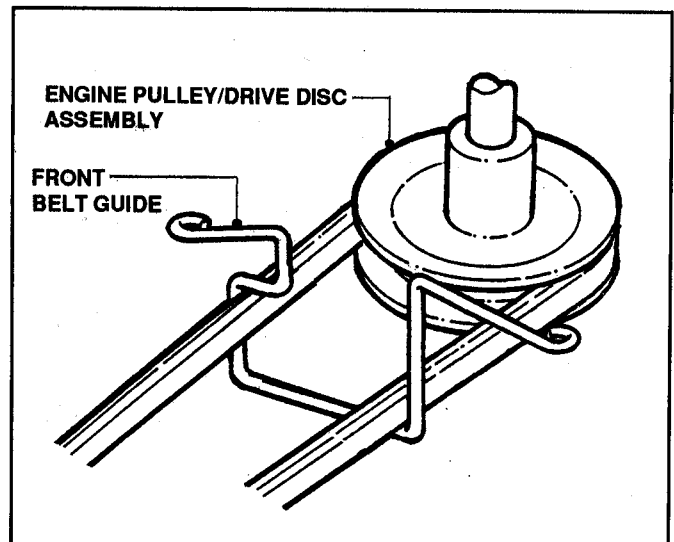

FIGURE 4.23

8. Route belt onto spindle pulley. Make sure belt is inside spindle belt guide.

Section IV- ADJUSTMENTS & REPAIR

9. Reinstall idler removed in step 1. The idler belt guide will self locate on tab. Tighten bolt securely.
10. Adjust belt guide. See Figure 4.24 for proper belt to belt guide clearances.

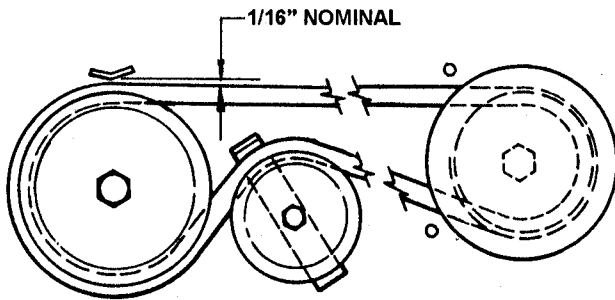
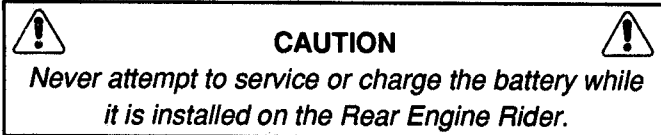

FIGURE 4.24

11. Check mower drive belt tension and adjust as necessary. Refer to 4.2, A. MOWER DRIVE BELT ADJUSTMENT.
12. Reinstall mower drive belt cover.

4.6 BATTERY

A. BATTERY REMOVAL



1. Carefully pull each side of battery cover away from ratchet fasteners and remove cover. See Figure 4.25.

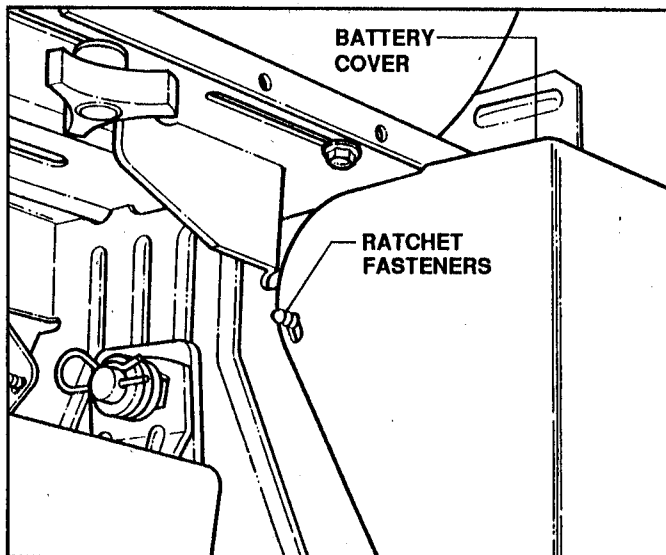

FIGURE 4.25

2. Slide battery from battery box to gain access to terminal cables.
3. Observe and note cable positions on battery. See Figure 4.26.

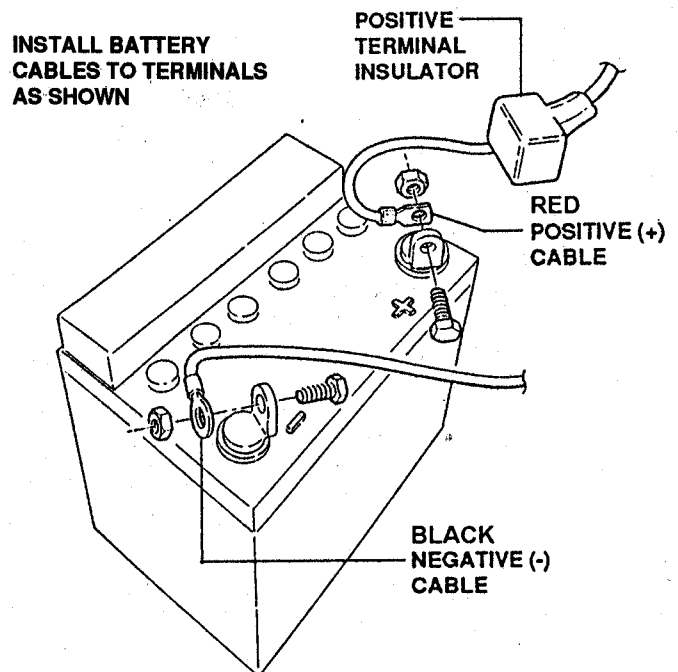
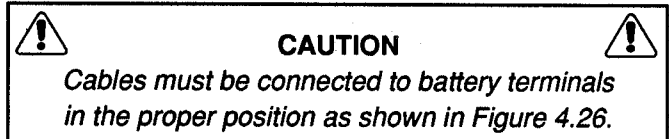

FIGURE 4.26

4. Disconnect cables from battery terminals. Retain mounting bolts and nuts.

B. BATTERY INSTALLATION

1. Slide battery partially into battery housing.
2. Connect cables to battery terminals.



3. Reinstall battery cover. Refer to Figure 4.25.

C. BATTERY SERVICE

1. Remove battery.
2. Using distilled water, refill cells as required to no more than 3/16" above cell plates.

D. CHARGING BATTERY

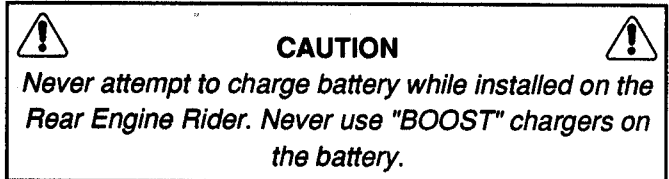

1. Remove battery.
2. Place battery in a well ventilated area on a level surface.
3. Remove battery cell caps. Check fluid level of each cell. Fill cells as required with distilled water to proper level.

SNAPPER®

2 YEAR LIMITED WARRANTY

For **two (2) years** from purchase date for the original purchaser's **residential**, non-commercial use, **SNAPPER**, through any **SNAPPER** dealer will replace, free of charge, any part or parts found upon examination by the factory at McDonough, Georgia, to be defective in material or workmanship or both.

For **ninety (90) days** from purchase date for the original purchaser's **commercial**, rental, or other non-residential use, **SNAPPER**, through any **SNAPPER** dealer will replace, free of charge, any part or parts found upon examination by the factory at McDonough, Georgia, to be defective in material or workmanship or both.

All transportation costs incurred by the purchaser in submitting material to a **SNAPPER** dealer for replacement under this warranty must be paid by the purchaser.

This warranty does not apply to engines and their components, or, Peerless® Transaxles, as these items are warranted separately by their manufacturers. This warranty does not apply to parts that have been damaged by accident, alteration, abuse, improper lubrication, normal wear, or other cause beyond our control.

There is no other express warranty.

Implied warranties, including those of merchantability and fitness for a particular purpose, are limited to two (2) years from purchase date for the original purchaser's residential, non-commercial use [ninety (90) days from purchase for the original purchaser's commercial, rental or other non-residential use], and to the extent permitted by law, any and all implied warranties are excluded. This is the exclusive remedy. Liabilities for consequential damages, under any and all warranties are excluded.

Some states do not allow limitations on how long an implied warranty lasts, or do not allow the exclusion or limitation of incidental or consequential damages, so the above limitation or exclusion may not apply to you.

This warranty gives you specific legal rights, and you may also have other rights which vary from state to state.

WARNING: THE USE OF REPLACEMENT PARTS OTHER THAN GENUINE SNAPPER PARTS MAY IMPAIR THE SAFETY OF SNAPPER PRODUCTS AND WILL VOID ANY LIABILITY AND WARRANTY BY SNAPPER ASSOCIATED WITH THE USE OF SUCH PARTS.

IMPORTANT: Please fill out the attached **SNAPPER** Product Registration Card immediately and mail to:
SNAPPER, McDONOUGH, GEORGIA 30253

Safety Instructions & Operator's Manual for

SNAPPER®

**Series 14
REAR ENGINE RIDING MOWERS**

Models:

250814B, 250814BE, 280914BE, 300914BE, 301014BE, 301214BE, 331314BE, 331414KVE

ACCESSORIES

Below is a list of popular accessories available for the SNAPPER Series 14 Rear Engine Riding Mowers. Contact an authorized SNAPPER dealer under lawnmowers in the yellow pages to obtain any of these accessories.

Rear Engine Riders with 25" Cutting Decks

ORDER NUMBER	DESCRIPTION
6-0197	Load Carrier Kit
6-0441	Commercial Axle Bearing Kit
6-0517	Wheel Weight
6-0601	Smooth Start Clutch Kit
6-0697	Dump Cart
6-0737	Gauge Wheel Kit
6-0753	Battery Kit
6-0941	Single Bag Catcher
6-1049	Recycling Kit
6-1190	Weight Kit
6-0948	Thatcherizer

Rear Engine Riders with 30" Cutting Decks

ORDER NUMBER	DESCRIPTION
6-0197	Load Carrier Kit
6-0441	Commercial Axle Bearing Kit
6-0517	Wheel Weight
6-0601	Smooth Start Clutch Kit
6-0697	Dump Cart
6-0737	Gauge Wheel Kit
6-0753	Battery Kit
6-1192	Weight Kit
6-0942	Single Bag Catcher
6-1254	Ninja™ Kit
6-0948	Thatcherizer

Rear Engine Riders with 28" Cutting Decks

ORDER NUMBER	DESCRIPTION
6-0197	Load Carrier Kit
6-0441	Commercial Axle Bearing Kit
6-0517	Wheel Weight
6-0601	Smooth Start Clutch Kit
6-0697	Dump Cart
6-0737	Gauge Wheel Kit
6-0753	Battery Kit
6-1190	Weight Kit
6-0943	Single Bag Catcher
6-0946	Twin Bag Catcher
6-0947	Bag-N-Wagon
6-0984	Wagon Cover Kit
6-1253	Ninja™ Kit
6-0948	Thatcherizer

Rear Engine Riders with 33" Cutting Decks

ORDER NUMBER	DESCRIPTION
6-0197	Load Carrier Kit
6-0441	Commercial Axle Bearing Kit
6-0517	Wheel Weight
6-0601	Smooth Start Clutch Kit
6-0697	Dump Cart
6-0737	Gauge Wheel Kit
6-0753	Battery Kit
6-1190	Weight Kit
6-0943	Single Bag Catcher
6-0946	Twin Bag Catcher
6-0947	Bag-N-Wagon
6-0984	Wagon Cover Kit
6-1255	Ninja™ Kit
6-0948	Thatcherizer

SNAPPER® McDonough, GA., 30253 U.S.A.