

*Safety Instructions & Operator's Manual for*  
**SNAPPER®**  
**22" WALK BEHIND**  
**MOWERS**



**Models**

**S2265FC (7800262)**  
**SP2265FC (7800263)**  
**SPV22675HWFC (7800264)**

NOTE: Specifications are correct at time of printing and are subject to change without notice.

\* Actual sustained engine power will likely be lower due to operating limitations and environmental factors. Please refer to 'Engine Power Rating Information' for further details.

**Thank You** for purchasing this quality-built Snapper mower. We're pleased that you placed your confidence in the Snapper brand. When operated and maintained according to the instructions in this manual, your Snapper mower will provide many years of dependable service.

**This manual contains** safety information to make you aware of the hazards and risks associated with the machine and how to avoid them. This machine is designed and intended only for finish cutting of established lawns and is not intended for any other purpose. It is important that you read and understand these instructions thoroughly before attempting to start or operate this equipment. Save these instructions for future reference.

## **PRODUCT REGISTRATION**

**IMPORTANT: KEEP THIS INFORMATION FOR YOUR PERSONAL RECORDS**  
(Complete the following information on your Snapper purchase)

**Date of Purchase** \_\_\_\_\_

**Retailer** \_\_\_\_\_

**Retailer's Phone Number** \_\_\_\_\_

### **Equipment**

Model Number \_\_\_\_\_

Serial Number \_\_\_\_\_

### **Engine**

Model \_\_\_\_\_ Type \_\_\_\_\_ Trim \_\_\_\_\_

**It is very important that you register your purchase with Snapper to ensure warranty coverage. Please mail your product registration card to:**

**Snapper at P.O. Box 1379, McDonough, Georgia 30253.**

**You can contact us at our website ([www.snapper.com](http://www.snapper.com)), or if you would like to speak with a Customer Service Representative, call us at the Snapper Customer Relations Center at 1-800-317-7833. For faster service please have your Serial Number and Model Number available.**

# Table of Contents

- Operator Safety . . . . .2**
  - Important Operator Safety Instructions . . . . .2
- Preparation . . . . .4**
  - Unpacking . . . . .4
  - Handle . . . . .4
  - Handle Height . . . . .5
  - Grass Bag . . . . .6
  - Side Discharge Deflector . . . . .8
  - Mulching Tips . . . . .9
  - How to Prepare the Engine . . . . .9
  - Final Preparation . . . . .9
- Operation . . . . .10**
  - Engine Stop Lever . . . . .10
  - Front Wheel Drive System (Self-Propelled Units) . . . . .10
  - Stopping the Engine . . . . .10
  - Starting the Engine . . . . .11
  - Rules for Safe and Effective Operation . . . . .11
- Maintenance . . . . .12**
  - Engine Maintenance . . . . .12
  - Engine Tipping . . . . .12
  - Cleaning the Mower Housing . . . . .12
  - Lubrication . . . . .12
  - Adjusting the Height of Cut . . . . .12
  - Removing the Drive Belt . . . . .13
  - Adjusting the Drive Cable . . . . .14
  - Blade Service . . . . .15
    - Removing the Blade . . . . .15
    - Sharpening the Blade . . . . .15
    - Checking the Level of Cut . . . . .15
  - Preparing the Mower for Storage . . . . .16
- Troubleshooting . . . . .17**
- Warranty . . . . .18**

WARNING

Battery posts, terminals and related accessories contain lead and lead compounds, chemicals known to the State of California to cause cancer and birth defects or other reproductive harm. Wash hands after handling.

WARNING

Engine exhaust, some of its constituents, and certain vehicle components contain or emit chemicals known to the State of California to cause cancer or other reproductive harm.



## IMPORTANT OPERATOR SAFETY INSTRUCTIONS



**WARNING:** This powerful cutting machine is capable of amputating hands and feet and can throw objects that can cause injury and damage! Failure to comply with the following SAFETY instructions could result in serious injury or death to the operator or other persons. The owner of the machine must understand these instructions and must allow only persons who understand these instructions to operate machine. Each person operating the machine must be of sound mind and body and must not be under the influence of any substance, which might impair vision, dexterity or judgment. If you have any questions pertaining to your machine which your dealer cannot answer to your satisfaction, call or write the Customer Service Department at SNAPPER, McDonough, Georgia 30253. Phone: (1-800-317-7833).

### Protection for Children

Tragic accidents can occur if the operator is not alert to the presence of children. Children are often attracted to the machine and the mowing activity. Never assume that children will remain where you last saw them.

1. KEEP children out of the mowing area and under the watchful care of a responsible adult other than the operator.
2. DO NOT allow children in yard when machine is operated and turn machine OFF if anyone enters the area.
3. DO NOT allow pre-teenage children to operate machine.
4. ALLOW only responsible adults & teenagers with mature judgment under close adult supervision to operate machine.
5. DO NOT pull mower backwards unless absolutely necessary. LOOK and SEE behind and down for children, pets and hazards before and while backing.
6. USE EXTRA CARE when approaching blind corners, shrubs, trees, or other objects that may obscure vision.

### Slope Operation

1. Slopes are a major factor related to slip and fall accidents, which can result in severe injury. All slopes require extra caution. If you feel uneasy on a slope, DO NOT mow it.
2. Mow across slopes, never up-and-down. Exercise extreme CAUTION when changing directions on slopes. DO NOT mow steep slopes or other areas where stability or traction is in doubt. Refer to the Slope Guide at the end of this manual.
3. Use extra care with grass catchers or other attachments; these affect the handling and the stability of the machine.

### Preparation

1. Read, understand, and follow instructions and warnings in this manual and on the mower, engine and attachments. Know the controls and the proper use of the mower before starting.
2. Only mature, responsible persons shall operate the machine and only after proper instruction.
3. Data indicates that operators age 60 and above, are involved in a large percentage of mower-related injuries. These operators should evaluate their ability to operate the mower safely enough to protect themselves and others from serious injury.

### Preparation

#### (Continued From Previous Column)

4. Handle fuel with extra care. Fuels are flammable and vapors are explosive. Use only an approved fuel container. DO NOT remove fuel cap or add fuel with engine running. Add fuel outdoors only with engine stopped and cool. Clean spilled fuel and oil from machine. DO NOT smoke.
5. Check the area to be mowed and remove all objects such as toys, wire, rocks, limbs and other objects that could cause injury if thrown by blade or interfere with mowing. Also note the location of holes, stumps, and other possible hazards.
6. Keep people and pets out of the mowing area. Immediately, STOP Blade, Stop engine and Stop mower if anyone enters the area.
7. Check shields, deflectors, switches, blade controls and other safety devices frequently for proper operation and location.
8. Make sure all safety decals are clearly legible. Replace if damaged.
9. Protect yourself when mowing and wear safety glasses, a dust mask, long pants, and substantial footwear. DO NOT mow barefooted or with sandals.
10. Know how to STOP blade and engine quickly in preparation for emergencies.
11. Use extra care when loading or unloading the machine into a trailer or truck.
12. Check grass catcher components frequently for signs of wear or deterioration and replace as needed to prevent injury from thrown objects going through weak or torn spots.

### Safe Handling of Gasoline

To avoid personal injury or property damage, use extreme care in handling gasoline. Gasoline is extremely flammable and the vapors are explosive.

1. Extinguish all cigarettes, cigars, pipes and other sources of ignition.
2. Use only an approved fuel container.
3. DO NOT remove fuel cap or add fuel with the engine running. Allow the engine to cool before refueling.
4. DO NOT refuel the machine indoors.
5. DO NOT store the machine or fuel container inside where there is an open flame, spark or pilot light such as on a water heater or other appliances.



## Important Operator Safety Instructions (Continued)



### Safe Handling of Gasoline (Continued From Previous Page)

6. DO NOT fill fuel containers inside a vehicle or on a truck or trailer bed with a plastic liner. Always place the containers on the ground away from the vehicle before filling.
7. Remove gas-powered equipment from the vehicle or trailer and refuel it on the ground. If this is not possible, then refuel equipment using a portable container, rather than a gasoline dispenser nozzle.
8. DO NOT start gas powered equipment in enclosed vehicles or trailers.
9. Keep the nozzle in contact with the rim of the fuel tank or container opening at all times until fueling is complete. DO NOT use a nozzle lock-open device
10. If fuel is spilled on clothing, change clothing immediately.
11. DO NOT overfill a fuel tank. Replace fuel cap and tighten securely.

### Operation

1. DO NOT put hands or feet near or under rotating parts. Keep clear of discharge area while engine is running.
2. STOP engine when crossing gravel drives, walks, or roads, and under any conditions where thrown objects might be a hazard.
3. Mow only in daylight or good artificial light.
4. DO NOT operate mower while under the influence of alcohol or drugs.
5. After striking a foreign object or if mower vibrates abnormally, STOP the engine, disconnect and secure spark plug wire. Inspect the mower for any damage and repair the damage before starting.
6. DO NOT mow near drop offs, ditches or embankments. Operator could lose footing or balance.
7. STAY ALERT for holes and other hidden hazards. Tall grass can hide obstacles. Keep away from ditches, washouts, culverts, fences and protruding objects.
8. DO NOT mow on wet grass. Always be sure of your footing. Keep a firm hold on the handle and walk, never run. Slipping could cause injury.
9. ALWAYS stay behind handle when engine (motor) is running.
10. DO NOT leave the machine with the engine running. STOP BLADE and STOP ENGINE before leaving the operators position for any reason.
11. Before cleaning, repairing or inspecting make certain engine, blade and all moving parts have STOPPED. Disconnect and secure spark plug wire away from plug to prevent accidental starting.
12. STOP engine and wait until the blade comes to complete STOP before removing grass bag and/or clearing grass.

### Operation (Continued From Previous Column)

13. DO NOT operate mower without the entire grass catcher, or guards in place discharge guard, rear guard or other safety devices in place and working. DO NOT point discharge at people, passing cars, windows or doors.
14. DO NOT discharge material against a wall or obstruction. Material may ricochet back towards the operator.
15. Slow down before turning.
16. Watch out for traffic when near or crossing roadways.
17. DO NOT operate engine in enclosed areas. Engine exhaust gases contain carbon monoxide, a deadly poison.
18. Only use accessories approved by the manufacturer. See manufacturer's instructions for proper operation and installation of accessories.

### Maintenance and Storage

1. DO NOT store mower or fuel container inside where fumes may reach an open flame, spark or pilot light such as in a water heater, furnace, clothes dryer or other gas appliance. Allow engine to cool before storing machine in an enclosure. Store fuel container out of reach of children in a well ventilated, unoccupied building.
2. Keep mower and engine free of grass, leaves or excess grease to reduce fire hazard and engine overheating.
3. When draining fuel tank, drain fuel into an approved container outdoors and away from open flame.
4. Keep all bolts, especially blade bolts, nuts and screws properly tight. Check that all cotter pins are in proper position.
5. Always provide adequate ventilation when running engine. Engine exhaust gases contain carbon monoxide, a deadly poison.
6. Service engine and make adjustments only when engine is stopped. Removed spark plug wire from spark plug and secure wire away from spark plug to prevent accidental starting.
7. DO NOT change engine governor speed settings or overspeed engine.
8. Check grass bag assembly frequently for wear or deterioration to avoid thrown objects and exposure to moving parts. Replace with new bag if loose seams or tears are evident. Replace slider or bag adapter if broken or cracked.
9. Mower blades are sharp and can cut. Wrap the blades or wear heavy leather gloves and use CAUTION when handling them.
10. DO NOT test for spark by grounding spark plug next to spark plug hole; spark plug could ignite gas exiting engine.
11. Have machine serviced by an authorized SNAPPER dealer at least once a year and have the dealer install any new safety devices.
12. Use only genuine SNAPPER replacement parts to assure that original standards are maintained.

# Preparation



**WARNING:** Before doing any assembly or maintenance to the mower, remove the wire from the spark plug.

*NOTE:* In this instruction book, left and right describe the location of a part with the operator standing behind the handle.

## Unpacking

The mower was fully assembled at the factory. When the mower was put in the carton, the handle was put in the storage position. To put the handle in the operating position, follow the steps below.

## Handle

1. Remove the mower from the carton.
2. Remove all packing material from the mower and the handle.
3. Turn the knobs **(A, Figure 1)** on either side of the lower handle **(B)** to retract the locking pins. Raise the lower handle, aligning it with one of the three sets of holes in the handle brackets **(C)**. Turn the knobs to release the locking pins and secure the lower handle.
4. Put the upper handle **(A, Figure 2)** in the operating (upright) position. Tighten the wingnuts **(B)**.

*NOTE:* The height of the handle can be set for operator comfort. See "Handle Height".

**CAUTION:** Be careful when you fold or raise the handle. Do not damage the cables. A cable that is bent will not work correctly. Before you use the unit, replace a bent or damaged cable.

5. Hold the engine stop lever against the handle. (Refer to section entitled 'Engine Stop Lever'.) Slowly pull the recoil-start grip **(A, Figure 3)**. To attach the recoil-start grip to the rope guide **(B)**, twist the rope through the rope guide mounted on the right side of the handle.

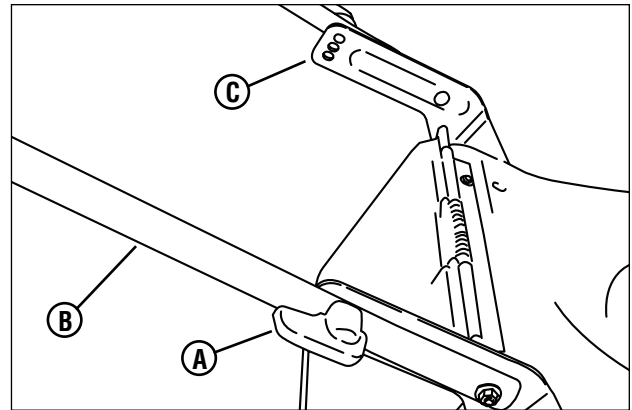

Figure 1: Unfolding the lower handle

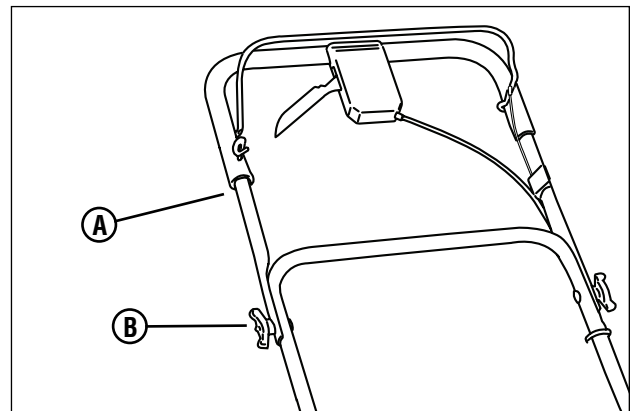

Figure 2: Unfolding the upper handle

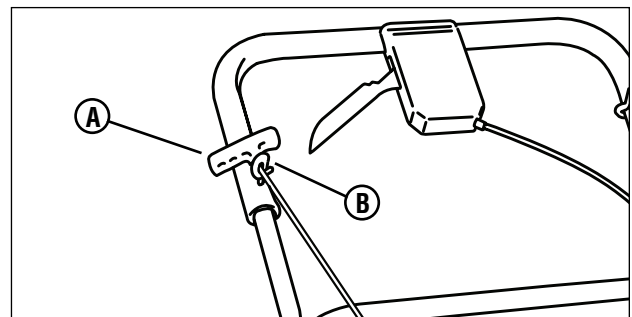

Figure 3: Attaching the recoil-start grip

## Preparation (Continued)

### Handle Height

1. Turn the knobs **(A, Figure 4)** on either side of the lower handle **(B)** to retract the locking pins. Align the lower handle with the desired set of holes in the handle brackets **(C)**. Turn the knobs to release the locking pins and secure the lower handle.

*Note: Do not remove the lower set of bolts and nuts securing the lower handle.*

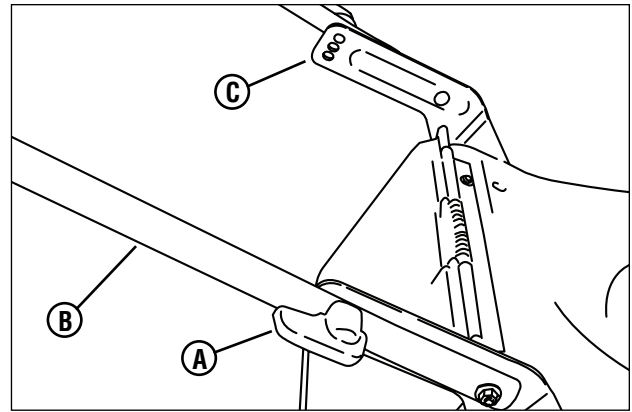

Figure 4: Adjusting the handle height

# Preparation (Continued)

## Assembling the Grass Bag

*Note: On some models, the side mounted discharge deflector is temporarily attached (for shipping purposes) to the rear of the mower. Before assembly of the grass bag, remove the side mounted discharge deflector.*

Preparation

1. Slide the frame assembly **(A, Figure 5)** into the grass bag **(B)**.

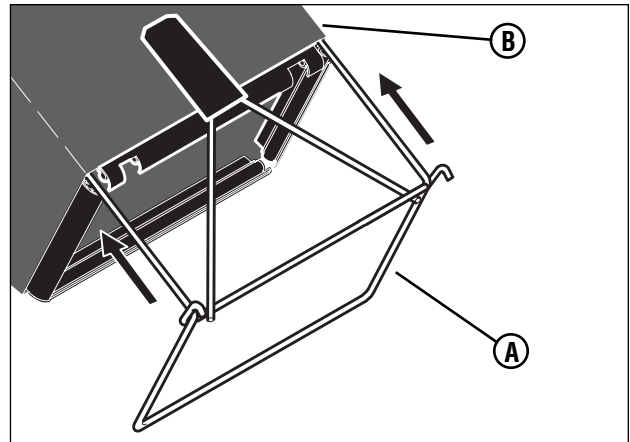

Figure 5: Installing the frame assembly

2. Make sure the handle **(A, Figure 6)** is on the outside of the grass bag.
3. First, attach the clips **(B, Figure 6)** to the side of the frame assembly **(C)**. Next, attach the clips to the top and bottom of the frame assembly.

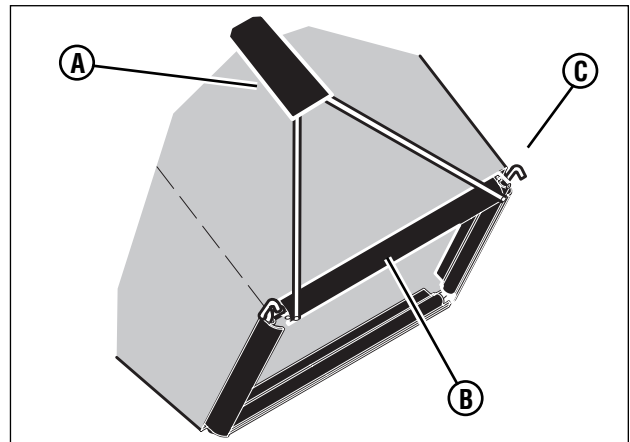

Figure 6: Installing the bag clips



## Preparation (Continued)

### Mounting the Grass Bag

1. To mount the grass bag on the mower, raise the rear door (A, Figure 7). Holding the grass bag by the handle (B), mount the hooks (C) on either end of the grass bag frame assembly onto the rear door pivot rod (D). Lower the grass bag against the rear of the mower. Lower the rear door.

*Important: Make sure both grass bag hooks are mounted on the pivot rod.*



**WARNING:** Check the condition of the grass bag for wear or deterioration. If worn or damaged, replace the parts only with approved factory replacement parts.

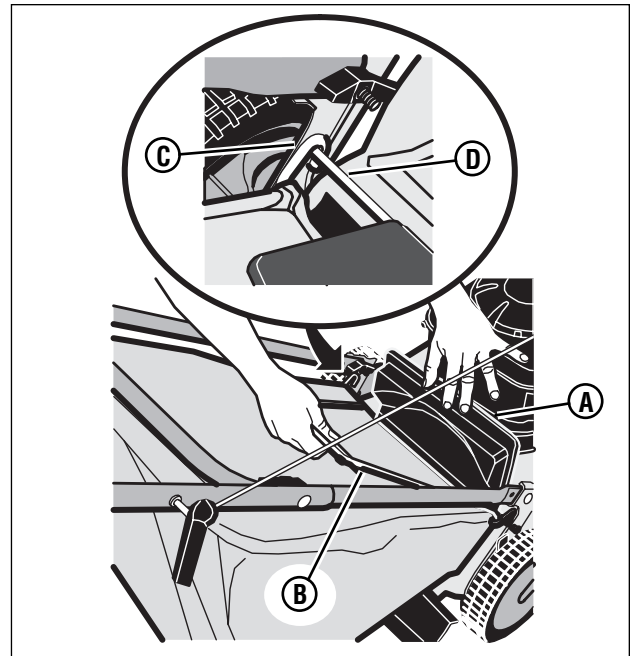

Figure 7: Mounting the grass bag

### Emptying the Grass Bag



**WARNING:** Before you remove the grass bag, stop the engine. Before you remove any grass from the mower housing, disconnect the wire from the spark plug.

1. Raise the rear door to a vertical position.
2. Hold the handle of the grass bag and lift the frame assembly. Continue to lift the frame assembly until the hooks are no longer mounted on the pivot rod. Remove the grass bag.
3. Empty the grass from the grass bag.
4. To mount the grass bag on the mower, see "Mounting The Grass Bag".

## Preparation (Continued)

### Attaching the Side Mounted Discharge Deflector



**WARNING:** To prevent the engine from starting, disconnect the wire from the spark plug.

For shipping purposes, the side deflector was not installed. Locate the side deflector and install as follows.

1. Raise the mulcher cover (**A**, **Figure 8**).
2. Slide the two tabs (**B**) on the side deflector (**C**) under the pivot pin.
3. Lower the side deflector. Make sure the locking tab (**A**, **Figure 9**) goes through the slot in the side deflector.
4. Lower the mulcher cover (**A**, **Figure 10**).
5. Attach the wire to the spark plug.

Preparation

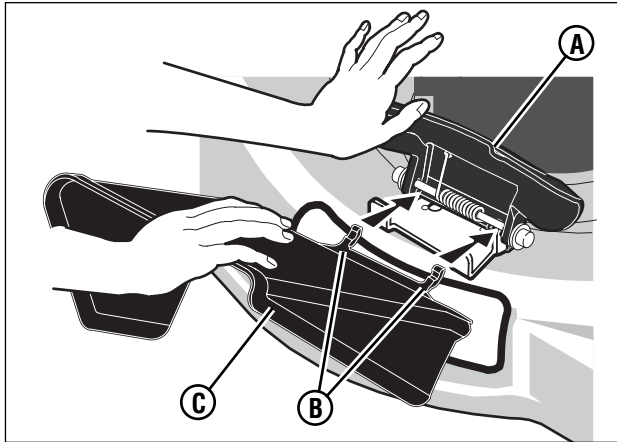

Figure 8: Installing the side discharge deflector

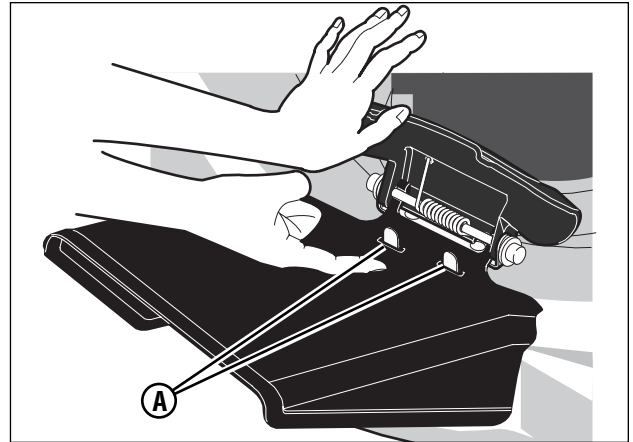

Figure 9: Side discharge deflector locking tabs

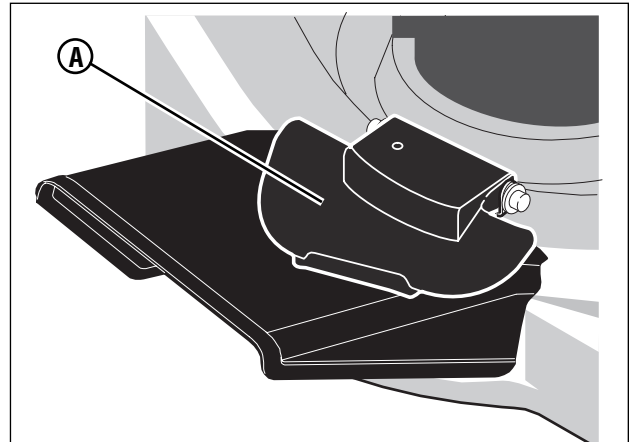

Figure 10: Releasing the mulcher cover

## Preparation (Continued)

### Mulching Tips

Mulching finely cuts the grass so that the grass can be easily recycled. Because the nutrients are returned to the soil, the lawn will need less fertilizer. To correctly mulch the lawn, follow the tips below.

- The grass must be dry. If the grass is wet, it will be difficult to cut and cause heavy clumps of grass.
- The grass must not be too tall. The maximum height to effectively cut is 4 1/2 inches. Set the height adjusters so that only the top third of the grass is cut.
- If the grass is more than 4 1/2 inches high, two mowings will be necessary. For the first mowing, set the height adjusters in the highest position. Then, lower the height adjusters for the second mowing.

- Keep a sharp edge on the blade. A blade that is not sharp will cause the ends of the grass to become brown.
- Clean the underside of the mower housing. Grass and other debris can keep the mower from working correctly.

If the quality of cut is marginal, try the following:

- Set the height adjusters at a higher cutting height.
- Cut the grass more frequently.
- Operate the mower at a slower ground speed.
- Overlap the cutting swaths instead of cutting a full swath with each pass.
- Mow across the marginal areas a second time.

### Preparing the Engine

#### ENGINE DOES NOT CONTAIN OIL OR GASOLINE

Using the bottle of oil supplied in the carton, fill the engine with the proper amount of oil. See the engine manufacturer's instructions for the type of gasoline and oil to use. Before you use the unit, read the information on safety, operation, maintenance, and storage.



**WARNING: Follow the engine manufacturer's instructions for the type of gasoline and oil to use. Always use a safety gasoline container. Do not smoke when adding gasoline to the engine. When inside an enclosure, do not fill with gasoline. Before you add gasoline, stop the engine. Let the engine cool for several minutes.**

*Note: The operation of a new engine will sometimes result in a slight amount of smoke. This smoke is caused by paint or oil on or around the muffler. This is normal and only expected during initial operation.*

**IMPORTANT:** This unit is equipped with an internal combustion engine and must not be used on or near any unimproved forest-covered, brush-covered or grass-covered and unless the engine's exhaust system is equipped with a spark arrester meeting applicable local or state laws (if any). If a spark arrester is used, it must be maintained in effective working order by the operator.

In the State of California the above is required by law (Section 4442 of the California Public Resources Code). Other states may have similar laws. Federal laws apply on federal lands. See an Authorized Service Center for a spark arrester for the muffler.

*Note: Actual sustained engine power will likely be lower due to operating limitations and environmental factors.*

### Final Preparation

Before you use the mower, check the assembly of the wheels, the handle, and the controls. Make sure all the fasteners are tight. Make sure the throttle control (if equipped) and the engine stop lever work correctly.

If the mower is equipped with height adjusters, make sure the height adjusters function properly. Before starting the engine, make sure each height adjuster is set at the desired height. See "Adjusting The Height Of Cut" in the Maintenance sections.

# Operation

## Engine Stop Lever

Release the engine stop lever (**A**, **Figure 11**) and the engine and the blade will automatically stop. To run the engine, hold the engine stop lever in the Operating position (**B**).

Before you start the engine, operate the engine stop lever several times. Make sure the cable moves easily.

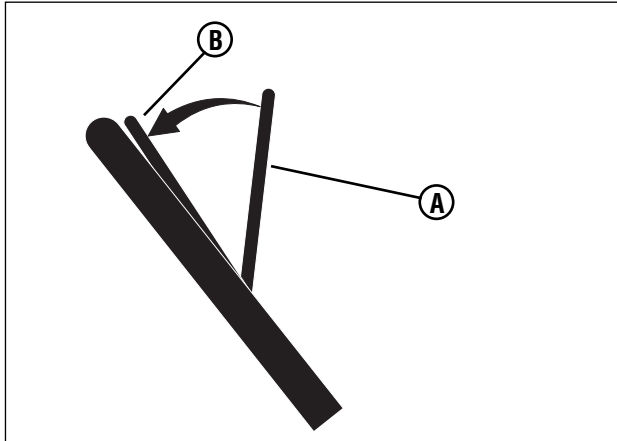

Figure 11: Operating the engine stop lever



**WARNING:** For safe operation, the drive system must immediately disengage when the drive lever is released. If the drive system does not disengage correctly, do not operate the mower until the drive system is adjusted or repaired by an authorized service center.

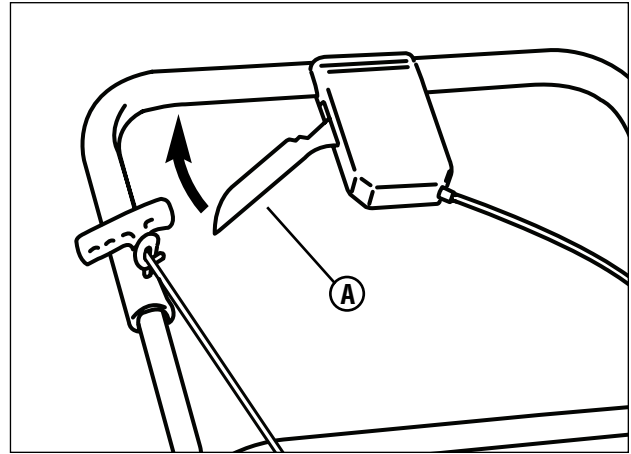

Figure 12: Operating the front wheel drive system

## Front Wheel Drive System (Self-Propelled Units Only)

The mower has a front wheel drive system. Operate the drive system as follows.

1. Hold the engine stop lever (**A**, **Figure 11**) in the Operating Position (**B**).
2. **Model SP2265FC:** Pull the drive lever (**A**, **Figure 12**) completely back. The drive system is now engaged.  
**Model SPV22675HWFC:** Slowly pull the drive lever back. The drive system is now engaged. To increase ground speed, slowly pull the drive lever farther back. To decrease ground speed, slowly release the drive lever.
3. To disengage the drive system and stop the engine, completely release the engine stop lever.
4. To disengage only the drive system, release the drive lever. The drive system will disengage but the engine will continue to run.

*Note: When the drive system is disengaged on a new unit, it is possible for the front wheels to rotate if lifted off the ground. This is normal and will stop after one or two hours of operation.*

## Stopping the Engine

To stop the engine, release the engine stop lever. Disconnect the wire from the spark plug to prevent the engine from starting.

If the engine will not stop, hold a screwdriver against the spark plug and against the engine cooling fins. The spark will go to ground and the engine will stop. Before you start the engine, check the engine stop cable. Make sure the engine stop cable is assembled correctly. Before you operate the unit, replace a bent or damaged engine stop cable.

# Operation (Continued)

## Starting the Engine



**WARNING:** The blade will rotate when the engine runs.

**IMPORTANT:** Before you start the engine, operate the engine stop lever several times. Make sure the engine stop cable moves freely.

*Note: The engine design does not include a throttle control or an engine speed adjustment. The engine is set at the best speed for cutting grass, bagging grass, and for extended engine life.*

1. Check the oil.
2. Fill the fuel tank with regular unleaded gasoline. Make sure the gasoline is clean. Leaded gasoline will increase deposits and shorten the life of the valves.

*Note: Do not use gasohol or methanol. Do not use premium unleaded gasoline.*



**WARNING:** Always use a safety gasoline container. Do not smoke when adding gasoline to the fuel tank. When inside an enclosure, do not add gasoline. Before you add gasoline, stop the engine and let the engine cool for several minutes.

3. Make sure the spark plug wire is connected to the spark plug.
4. *Self-Propelled Models Only* - Make sure the drive lever is in the disengaged position.



**WARNING:** To prevent an accident, make sure the drive lever is in the **DISENGAGED** position. When the drive lever is in the **ENGAGED** position, do not start the engine.

5. The primer button (**A, Figure 13**) is on the side of the engine. Push the primer button. Every time you push the primer button, wait two seconds. For the number of times required to push the primer button, see the engine manufacturer's instructions.

*Note: Do not use the primer button to start a warm engine.*

*Note: Models equipped with Ready Start™ engines do not feature a primer button. See the engine manufacturer's instructions for further information.*

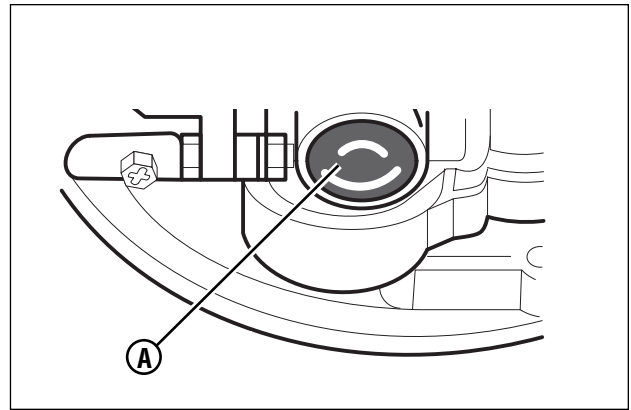

Figure 13: The engine primer button

6. Stand behind the mower. Use one hand to hold the engine stop lever in the operating position (**A, Figure 14**). Use the other hand to hold the recoil-start grip (**B**).
7. Make sure the recoil-start rope is not obstructed or caught between the upper and lower handles. Rapidly pull the recoil-start grip. Slowly return the recoil-start grip.
8. If the engine does not start in 5 or 6 tries, see the "Problem and Repair" Instructions.

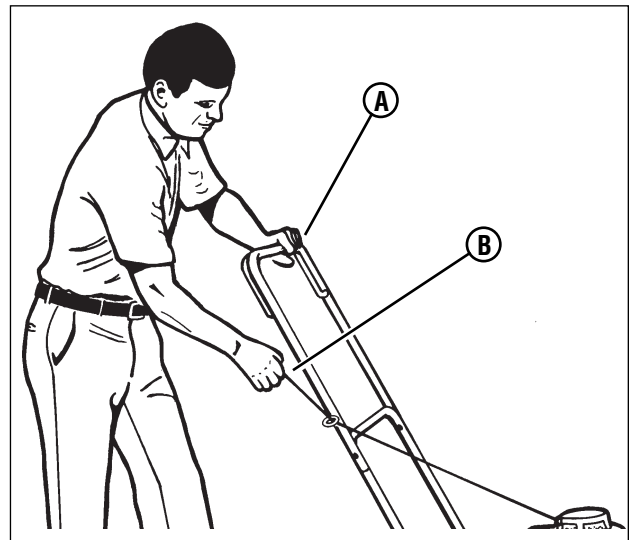

Figure 14: Starting the engine

## Rules for Safe and Effective Operation

Refer to the 'Operator Safety' section of this manual for important rules concerning safe and effective mower operation.

# Maintenance

## Engine Maintenance

Use the following maintenance section to keep your unit in good operating condition. All the maintenance information for the engine is in the “Engine Instruction Book”. Before you start the engine, read this book.



**WARNING:** Before you make an inspection, adjustment (except carburetor), or repair, stop the engine and disconnect the wire from the spark plug.

## Engine Tipping

When you service the engine, inspect the blade, or clean the underside of the mower housing; make sure to always tip the engine with the spark plug up (**Figure 15**). Transporting or tipping the engine with the spark plug down will cause:

- Hard starting.
- Engine smoking.
- Spark plug fouling.
- Oil or gas saturation of the air filter.



Figure 15: No forward engine tipping

## Cleaning the Mower Housing



**WARNING:** The blade will rotate when the engine runs. Before you clean the mower housing, stop the engine and disconnect the wire from the spark plug.

Grass and other debris can keep the mower from working correctly. After you mow, clean the mower housing as follows.

1. Stop the engine.
2. Disconnect the wire from the spark plug.
3. Clean dirt and debris from the top and the bottom of the mower housing. Clean with soap and water. Wipe off excess water before storage.

## Lubrication

1. For maximum performance, lubricate the wheels and all pivot points with engine oil every 25 hours.
2. To lubricate the engine, refer to the “Engine Instruction Book”.

*Note: Do not lubricate the engine stop cable. Lubricants will damage the cable and prevent the cable from moving freely. Replace the cable if bent or damaged.*

## Adjusting the Height of Cut



**WARNING:** The blade will rotate when the engine runs. Before you change the height of cut, stop the engine and disconnect the wire from the spark plug.

To change the height of cut, move the position of the adjuster arm at each wheel (**A, Figure 16**). Make sure each adjuster arm is in the same position so that the mower will cut level.

1. Disengage the adjuster arm.
2. Move the adjuster arm to another position.

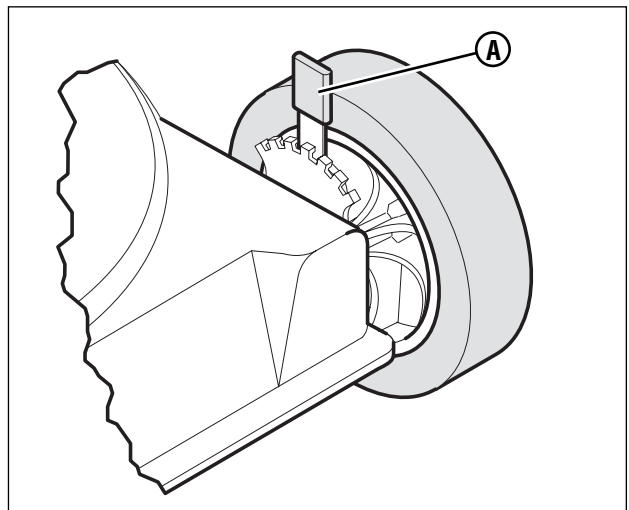

Figure 16: Adjusting the height of cut

## Maintenance (Continued)

### Removing the Drive Belt (Self-Propelled Units Only)



**WARNING:** Before you remove the belt, disconnect the wire from the spark plug.

1. Remove the screws that secure the belt cover (A, Figure 17). Remove the belt cover.

*Note:* The screws that secure the belt cover are located beneath the deck.

2. To remove the drive belt, tip the mower up. See “Engine Tipping” in the Maintenance section.
3. (SP2265FC Only): Loosen the belt tension bolt (A, Figure 18).

*Note:* Model SPV22675HWFC has a belt guide on the transmission that must be removed prior to belt removal. Be sure to replace after belt installation.

4. Remove the front of the drive belt (B) from the transmission pulley (C).
5. To remove the rear of the drive belt (A, Figure 19), slip the drive belt over the end of the blade (B).

*Note:* Model SPV22675HWFC has belt guides around the engine pulley that must be removed prior to belt removal. Be sure to replace after belt installation.

*Note:* Make sure you replace the drive belt only with a replacement belt from the factory.

6. To assemble the drive belt, reverse the above steps.
7. (SP2265FC Only): Set the belt tension.
  - a. Tighten the adjuster nut (A, Figure 20) until the nut touches the spacer (B). Try to turn the spacer. When the adjuster nut touches the spacer, the spacer will not turn.

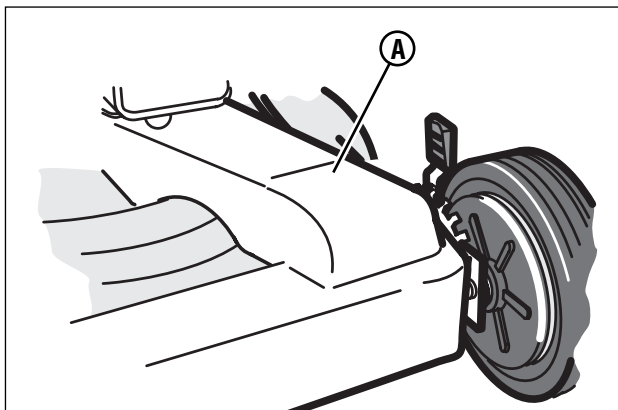

Figure 17: Removing the belt cover

b. Then, loosen the adjuster nut only enough to allow the spacer to turn. The tension on the drive belt is now correct.

8. Install the belt cover.
9. Before you begin to mow, make sure the drive system will correctly disengage and that the mower will stop. If the drive system will not disengage, take the mower to an authorized service center before you operate the mower.

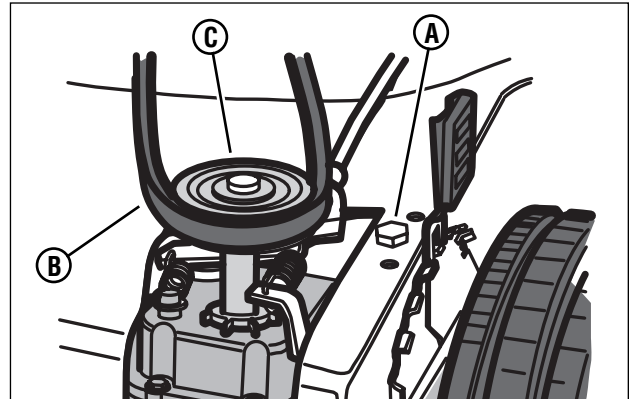

Figure 18: Loosening the belt tension bolt

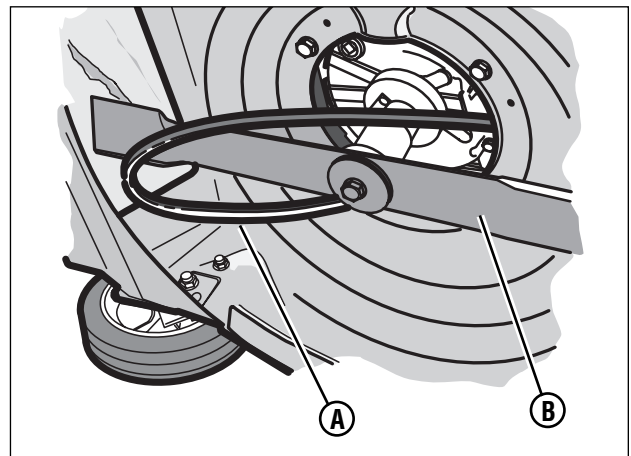

Figure 19: Removing the belt

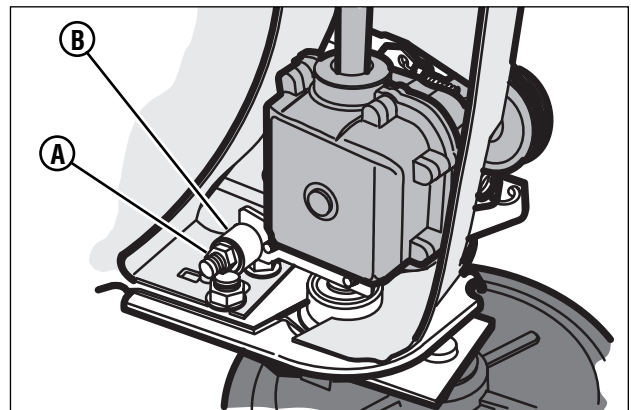

Figure 20: Setting the belt tension

## Maintenance (Continued)

### Adjusting the Drive Cable (Self-Propelled Units Only)



**WARNING:** Before you adjust the drive cable, release the engine stop lever and wait for the engine to stop.

If the drive system does not engage and disengage correctly, check the handle for correct assembly. Make sure that all parts are in good condition, not broken or bent, and that all fasteners are tight.

Worn parts and cable stretch will change the performance of the drive system. When you mow in high or thick grass or on hills, the drive system can slip. If the drive system is slipping, adjust as follows or take the mower to an authorized service center.

**IMPORTANT:** Before you start the engine, operate the engine stop lever several times. Make sure the engine stop cable moves freely.

*Note: The engine design does not include a throttle control or an engine speed adjustment. The engine is set at the best speed for cutting grass, bagging grass, and for extended engine life.*

1. If the drive system is slipping, loosen the jam nut (**B**, **Figure 21**) on the adjustment turnbuckle (**A**), and rotate the ferrule (**C**) one-half turn in the direction shown. Test the drive system and check for slippage.
2. If the drive system still slips, adjust again. Again, test the drive system.
3. Repeat the adjustment and test until the drive system does not slip.
4. Before you begin to mow, make sure the drive system will correctly disengage and that the mower will stop. If the drive system will not disengage, take the mower to an authorized service center before you operate the mower.

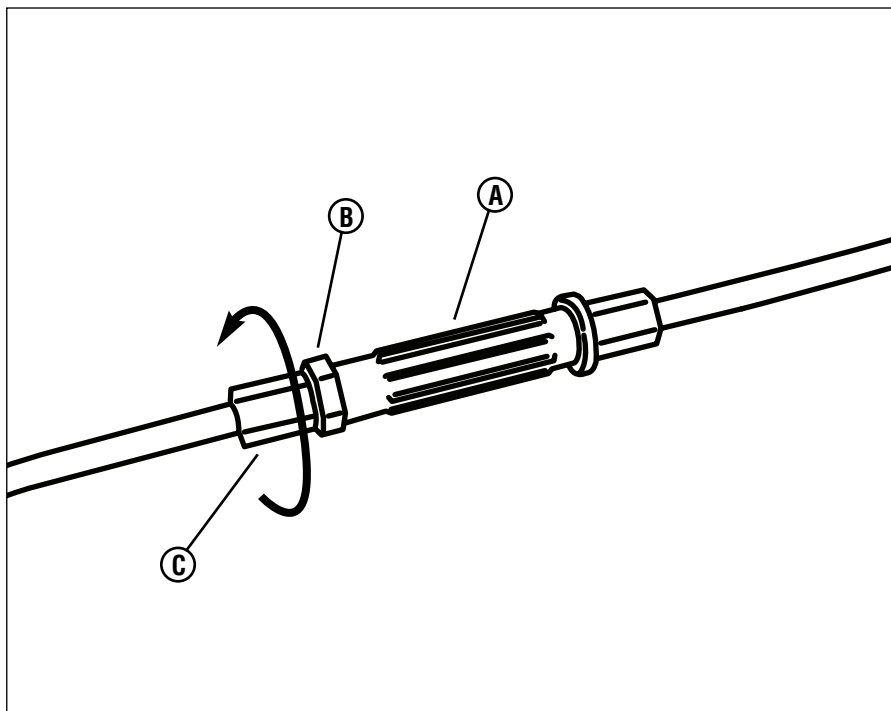

Figure 21: Adjusting the drive cable



# Maintenance (Continued)

## Blade Service



**WARNING:** Before you inspect the blade or the blade adapter, disconnect the wire to the spark plug. If the blade hits an object, stop the engine. Disconnect the wire to the spark plug. Check the unit for damage.

Frequently check the blade for wear or damage such as cracks. Frequently check the bolt that holds the blade. Keep the bolt tight. If the blade hits an object, stop the engine. Disconnect the wire to the spark plug. Check the blade adapter (**A, Figure 22**) for damage. Check for a bent or damaged blade, a badly worn blade, or other damage. Before you operate the unit, damaged parts must be replaced with factory replacement parts. For safety, replace the blade every two years. Keep a sharp edge on the blade. A blade that is not sharp will cause the ends of the grass to become brown. Remove the blade as follows.

## Removing the Blade



**WARNING:** Before you remove the blade, disconnect the wire to the spark plug. The blade has sharp edges. When you hold the blade, use gloves or cloth material to protect your hands.

1. Drain the fuel tank.
2. Lift the side of the mower that has the muffler or spark plug.
3. Use a piece of wood to keep the blade from rotating.
4. Remove the bolt (**B, Figure 22**) that holds the blade with a 9/16" (14mm) wrench.
5. Check the blade (**C**) according to the "Blade Service" instructions. Replace a badly worn or damaged blade with a factory replacement blade.
6. Mount the blade with the curved edges toward the housing. If the blade is upside down, the blade will not cut correctly and can cause an accident.
7. Fasten the blade with the original washer (**D**) and bolt. Make sure the outside rim of the Belleville washer is toward the blade.
8. Tighten the bolt that holds the blade to a torque of 30 foot pounds.



**WARNING:** Always keep the bolt that holds the blade tight. A loose bolt or blade can cause an accident.

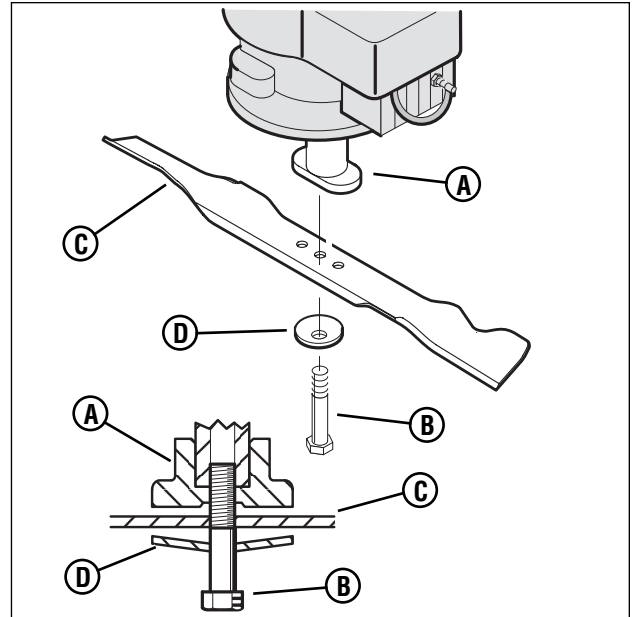

Figure 22: Removing the blade

## Sharpening the Blade



**WARNING:** Vibration is the result if the blade is not correctly balanced. A blade that is damaged with cracks can break and cause an accident.

1. Sharpen the blade two times a year or every 25 hours.
2. If the blade is on the unit, do not sharpen. Remove the blade according to the instructions in "Removing The Blade".
3. Clean the blade with a brush, soap, and water. Check the blade. Look for cracks, nicks, or other damage. Replace a blade that is badly worn, bent, or damaged with a factory replacement blade.
4. Sharpen the blade (**A, Figure 23, next page**) with a file (**B**). Make sure you keep the original beveled cutting edge.
5. Make sure the blade is balanced. Use a screwdriver (**C**) and hold the blade parallel to the ground (**D**) as shown. A blade that is balanced will stay parallel to the ground. If the blade is not balanced, the heavy end will rotate toward the ground. Sharpen the heavy end until the blade is balanced.
6. A new blade will cut better than a badly worn blade. Every two years replace the old blade with a factory replacement blade.

## Checking the Level of Cut

Test the unit in a small area. If the height of cut is not level or if the cut grass is not discharged, the cause can be: (1) the blade is bent or damaged, (2) the blade is not sharp, (3) a worn blade, (4) or a broken blade adapter. Before you use the unit, correct the problem.

## Maintenance (Continued)

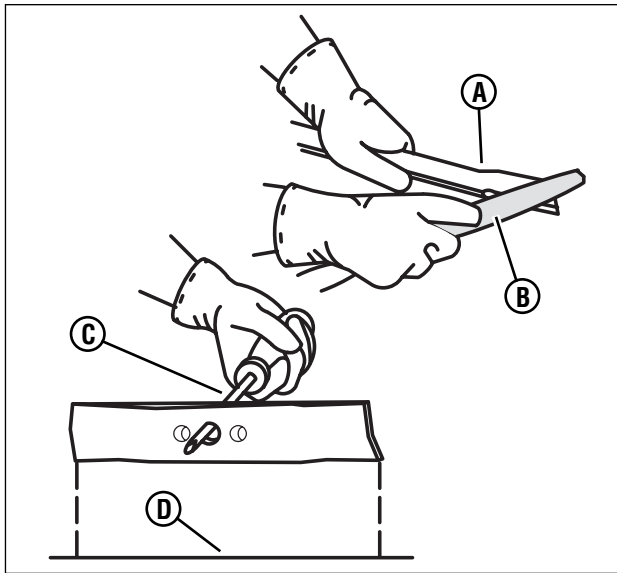

Figure 23: Sharpening the blade

### Preparing the Mower for Storage



**WARNING:** Do not remove gasoline while inside a building, near a fire, or while you smoke. Gasoline fumes can cause an explosion or a fire.

1. Drain the fuel tank.
2. Let the engine run until it is out of gasoline.
3. Drain the oil from the warm engine. Fill the engine crankcase with new oil.
4. Remove the spark plug from the cylinder. Pour one ounce of oil into the cylinder. Slowly pull the recoil-start grip so that the oil will protect the cylinder. Install a new spark plug in the cylinder.

5. Clean the dirt and debris from the cylinder cooling fins and the engine housing.
6. Clean the bottom of the mower housing.
7. Make sure the grass bag is empty of grass. Grass remaining in the bag during storage will damage the bag.
8. Completely clean the mower to protect the paint.
9. Fold the handles (if desired).

**CAUTION:** Be careful when you fold or raise the handle. Do not damage the cables. A cable that is bent will not work correctly. Before you use the unit, replace a bent or damaged cable.

10. Put the unit in a building that has good ventilation.

# Troubleshooting

## The engine will not start.

1. Make sure the fuel tank is filled with clean gasoline. Do not use old gasoline.
2. On a cold engine, push the primer button (optional on some models). For the number of times required to push the primer button, see the engine manufacturer's instructions.
3. Make sure the wire for the spark plug is connected to the spark plug.
4. Adjust the Carburetor. Refer to the engine manual.
5. There is too much gasoline in the engine cylinder. Remove and dry the spark plug. Pull the recoil-start grip several times. Install the spark plug. Connect the wire to the spark plug. Start the engine.
6. The engine is difficult to start in heavy or high grass. Move the mower to a clean dry surface.
7. Make sure the engine stop lever is in the operating position.
8. Make sure the fuel valve is in the ON position. Refer to the engine manual.

## The engine will not stop.

1. Release the engine stop lever.
2. Check the engine stop cable. Replace the cable if bent or damaged.

## Engine performance is bad.

1. Check the height of cut settings. Raise the height of cut if the grass is high.
2. Check the bottom of the blade housing. Clean the blade housing of grass and other debris.
3. Check the wire to the spark plug. Make sure the wire is connected.
4. Clean the engine cooling fins of grass and other debris.
5. Check the carburetor adjustments. Refer to the engine manual.
6. Check the spark plug gap. Set the spark plug gap at 0.030".
7. Check the amount of oil in the engine. Fill with oil if necessary.
8. Check the engine air cleaner. Refer to the engine manual.
9. The gasoline is bad. Drain and clean the fuel tank. Fill the fuel tank with clean gasoline.

## Excessive vibration.

1. Remove the blade. Check the blade and balance if necessary. See the blade maintenance instructions.
2. Check for a bent or broken blade. **A damaged blade is dangerous and must be replaced.**
3. Check the blade adapter. **Replace a broken blade adapter.**
4. If the vibration continues, take the mower to an Authorized Service Center.

## The grass will not discharge correctly.

1. Clean the bottom of the mower housing.
2. Check for a badly worn blade. Remove and sharpen the blade. For safety, replace the blade every two years with a factory replacement blade.

## The grass is not cut even.

1. Check the height adjustment at each wheel. The height adjustment must be the same for each wheel.
2. Make sure the blade is sharp.
3. Check for a bent or broken blade. **A damaged blade is dangerous and must be replaced.**
4. Check for a broken blade adapter. **Replace a broken blade adapter.**

# SNAPPER®

## 2 YEAR LIMITED WARRANTY

For two (2) years from purchase date for the original purchaser's residential, non-commercial use, SNAPPER, through any authorized SNAPPER dealer will replace, free of charge (except for taxes where applicable), any part or parts found upon examination by the factory at McDonough, Georgia, to be defective in material or workmanship or both.

For ninety (90) days from purchase date for the original purchaser's commercial, rental, or other non-residential use, SNAPPER, through any authorized SNAPPER dealer will replace, free of charge, any part or parts found upon examination by the factory at McDonough, Georgia, to be defective in material or workmanship or both.

All transportation costs incurred by the purchaser in submitting material to an authorized SNAPPER dealer for replacement under this warranty must be paid by the purchaser.

This warranty does not apply to certain transmissions, to engines and their components, and batteries, as these items are warranted separately. This warranty does not apply to parts that have been damaged by accident, alteration, abuse, improper lubrication, normal wear, or other cause beyond the control of SNAPPER. This warranty does not cover any machine or component part that has been altered or modified changing safety, performance, or durability.

Batteries have a one (1) year warranty period with free replacement if required for one (1) year from the original purchase date. SNAPPER will not be responsible for any installation cost incurred. The battery warranty only covers original equipment batteries and does not cover damage to the battery or machine caused by neglect or abuse, destruction by fire, explosion, freezing, overcharging, improper maintenance, or use of improper electrolyte.

There is no other express warranty.

---

### DISCLAIMER OF WARRANTY

**Implied warranties, including those of merchantability and fitness for a particular purpose, are limited to two (2) years from purchase date for the original purchaser's residential or other non-commercial use, and ninety (90) days from purchase for the original purchaser's commercial, rental or other non-residential use, and to the extent permitted by law, any and all implied warranties are excluded. This is the exclusive remedy. Liabilities for consequential damages, under any and all warranties are excluded.**

**Some states do not allow limitations on how long an implied warranty lasts, or do not allow the exclusion or limitation of incidental or consequential damages, so the above limitation or exclusion may not apply to you.**

---

This warranty gives you specific legal rights, and you may also have other rights which vary from state to state.

WARNING: THE USE OF REPLACEMENT PARTS OTHER THAN GENUINE SNAPPER PARTS MAY IMPAIR THE SAFETY OF SNAPPER PRODUCTS AND WILL VOID ANY LIABILITY AND WARRANTY BY SNAPPER ASSOCIATED WITH THE USE OF SUCH PARTS.

**IMPORTANT:** Please fill out the attached SNAPPER Product Registration Card immediately and mail to:  
**Snapper's Product Registration Center, P.O. Box 1379, McDonough, Georgia 30253**

# Slope Guide

## SLOPE GUIDE

SIGHT AND HOLD THIS GUIDE LEVEL WITH A VERTICAL TREE, A CORNER OF A STRUCTURE, A POWER LINE POLE, OR A FENCE.

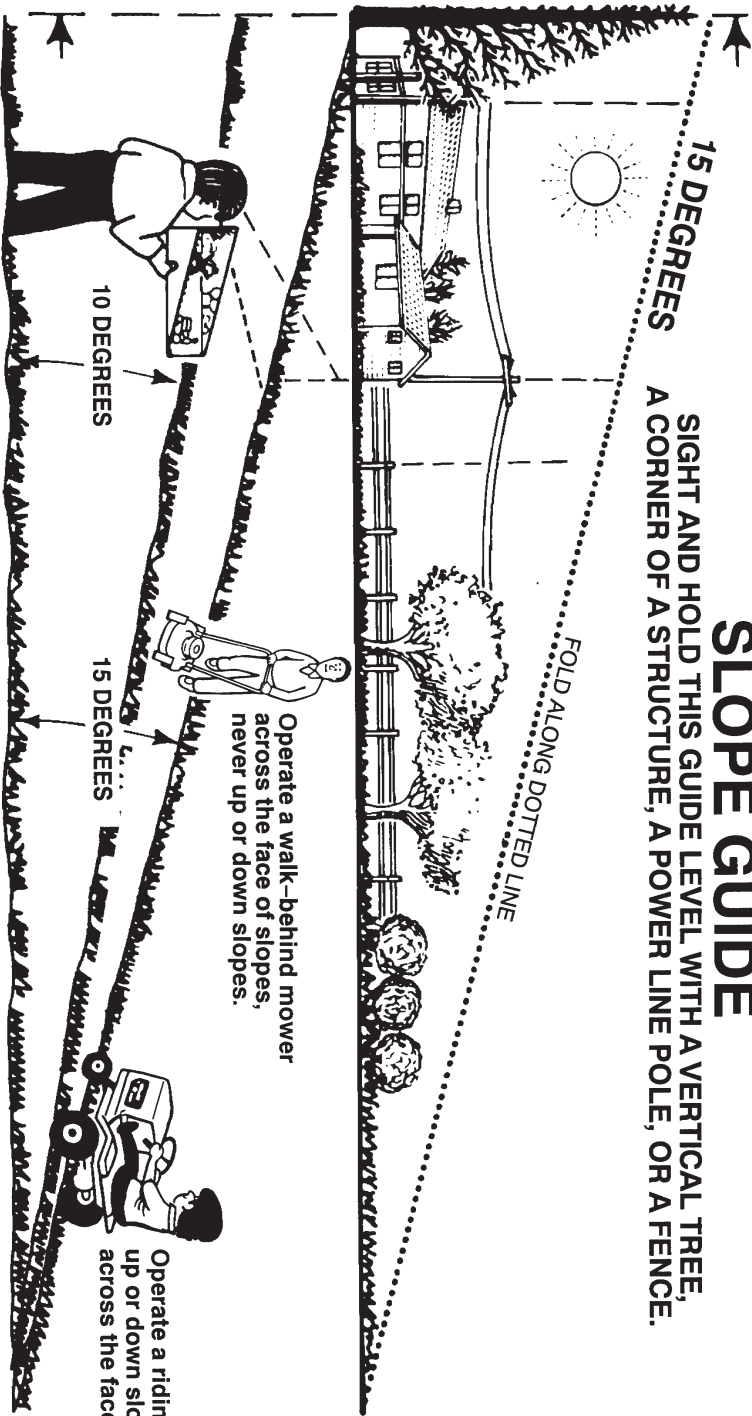

On a riding mower to determine if a slope is safe to mow: (1) disengage the blade(s), (2) put the unit in reverse, and (3) try to back straight up the slope. If you can back up the slope, it is generally safe to mow. However, if you do not feel safe, or if you are not completely sure, use this guide and do not mow a slope that is greater than 15 degrees. If the riding mower is used with a pull-behind or rear mounted attachment, do not operate the unit on a slope that is greater than 10 degrees.

A 15 degree slope is a hill that increases in height at approximately 2.5 feet in 10 feet. A 10 degree slope is a hill that increases in height at approximately 1.7 feet in 10 feet.



Use extreme care at all times, and avoid sudden turns or maneuvers. Follow other instructions in this manual for safety in mowing on slopes. Operate a riding mower up or down slopes, never across the face of slopes. Operate a walk-behind mower across the face of slopes, never up or down slopes. Use extra care when operating on or near slopes and obstructions.

CUT HERE TO USE SLOPE GUIDE





# SNAPPER®

## 22" WALK BEHIND MOWERS

---

Product Specifications	S2265FC	SP2265FC	SPV22675HWFC
Deck Size (in)	22	22	22
Height of Cut (in)	1.5 - 3.5	1.5 - 3.5	1.5 - 3.5
Transmission Type (Self-Propelled Units Only)	N/A	Single Speed/Gear	Variable Speed/Gear
Ground Speed (mph) (Self-Propelled Units Only)	N/A	2.3	0 - 4.2
Engine Power (ft lbs)	6.50	6.50	6.75
Engine Displacement (cc)	190	190	190
Fuel Tank Capacity (qt)	1.6	1.6	1.6

### Common Service Parts

Blade Control Cable (All)

Wheel Drive Cable (SP2265FC Only)

Wheel Drive Cable (SPV22675HWFC Only)

Cutter Blade (All)

Drive Belt (SP2265FC Only)

Drive Belt (SPV22675HWFC Only)

### Part Number

7101395

7101401

7101396

7100851

7101193

7100913

---

**Engine Power Rating Information:** The gross power rating for individual gas engine models is labeled in accordance with SAE (Society of Automotive Engineers) code J1940 (Small Engine Power & Torque Rating Procedure), and rating performance has been obtained and corrected in accordance with SAE J1995 (Revision 2002-05). Torque values are derived at 3060 RPM; horsepower values are derived at 3600 RPM. Actual gross engine power will be lower and is affected by, among other things, ambient operating conditions and engine-to-engine variability. Given both the wide array of products on which engines are placed and the variety of environmental issues applicable to operating the equipment, the gas engine will not develop the rated gross power when used in a given piece of power equipment (actual "on-site" or net horsepower). This difference is due to a variety of factors including, but not limited to, accessories (air cleaner, exhaust, charging, cooling, carburetor, fuel pump, etc.), application limitations, ambient operating conditions (temperature, humidity, altitude), and engine-to-engine variability. Due to manufacturing and capacity limitations, Briggs & Stratton may substitute an engine of higher rated power for this Series engine.