

Safety Instructions and Operator's Manual for

SNAPPER®

PRO GEAR EXPRESS WALK BEHIND MOWERS MID-SIZE SERIES 0



POWER UNIT MODEL
SPEL150KH

MOWER UNIT MODEL
SPE361 SPE481

MODEL NUMBER EXPLANATION				
S	P	EL	15	0 KH
MODEL DESIGNATION	MODEL TYPE	MODEL OPTION	ENGINE HORSE POWER	ENGINE TYPE
			CUTTING DECK WIDTH	SERIES DESIGNATION
				ENGINE HP
S – Snapper Commercial Model	ENGINE HORSE POWER	CUTTING DECK WIDTH	0 - Series Designation	KH – Kohler Engine
P – Pro Mid Size Model	15 – 15.0 Engine HP	361 – 36” Cutting Deck		
E – Express Model		481 – 48” Cutting Deck		
L – Loop Traction Controls				

Thank you for buying a SNAPPER Product! Before operating your PRO GEAR WALK BEHIND, read this manual carefully and pay particular attention to the “IMPORTANT SAFETY INSTRUCTIONS” on Pages 2 - 4. Remember that all power equipment can be dangerous if used improperly. Also keep in mind that SAFETY requires careful use in accordance with the operating instructions and common sense!

SNAPPER® McDonough, GA., 30253 U.S.A.



IMPORTANT SAFETY INSTRUCTIONS



WARNING: This powerful cutting machine is capable of amputating hands and feet and can throw objects that can cause injury and damage! Failure to comply with the following SAFETY instructions could result in serious injury or death to the operator or other persons. The owner of the machine must understand these instructions and must allow only persons who understand these instructions to operate machine. Each person operating the machine must be of sound mind and body and must not be under the influence of any substance, which might impair vision, dexterity or judgment. If you have any questions pertaining to your machine which your dealer cannot answer to your satisfaction, call or write the Customer Service Department at SNAPPER, McDonough, Georgia 30253. Phone: (1-800-935-2967).

PROTECTION FOR CHILDREN

Tragic accidents can occur if the operator is not alert to the presence of children. Children are often attracted to the machine and the mowing activity. Never assume that children will remain where you last saw them.

1. KEEP children out of the mowing area and under the watchful care of a responsible adult.
2. DO NOT allow children in yard when machine is operated (even with the blades OFF).
3. DO NOT allow children or others to ride on machine or on attachments (even with the blades OFF). They may fall and be seriously injured.
4. DO NOT allow pre-teenage children to operate or service the machine. Local regulations may restrict the age of the operator.
5. ALLOW only adults or responsible teenagers with mature judgment under close adult supervision to operate machine.
6. DO NOT operate blades in reverse. STOP BLADES. LOOK and SEE behind and down for children, pets and hazards before and while backing.
7. USE EXTRA CARE when approaching blind corners, shrubs, trees, or other objects that may obscure vision.

SLOPE OPERATION

1. Slopes are a major factor related to slip and fall accidents, which can result in severe injury. All slopes require extra caution and slow speed. If you feel uneasy on a slope, DO NOT mow it.
2. Mow across slopes, never up and down. Exercise extreme CAUTION when changing directions on slopes. Practice operation of machine on slopes with blades off.
3. Use extra care with grass catchers or other attachments: these affect the handling and the stability of the machine.
4. DO NOT use tow behind attachments on slopes.
5. AVOID uphill starts.
6. Turf conditions can affect the machine's stability. DO NOT operate machine under any condition where traction, steering or stability is doubtful.

PREPARATION

1. Read, understand and follow instructions and warnings in this manual and on the machine, engine, and attachments. Know the controls and the proper use of the machine before starting. If the operators or mechanics cannot read English, it is the owner's responsibility to explain this material to them.
2. Only mature, responsible persons shall operate the machine and only after proper instruction. The owner is responsible for training the operators. Further, the owner/operator can prevent and/or is responsible for accidents or injuries occurring to themselves, other people or property.
3. Data indicates that operators age 60 and above, are involved in a large percentage of mower-related injuries. These operators should evaluate their ability to operate the mower safely enough to protect themselves and others from serious injury.
4. Handle fuel with extra care. Fuels are flammable and vapors are explosive. Use only an approved fuel container. DO NOT remove fuel cap or add fuel with engine running. Add fuel outdoors only with engine stopped and cool. Clean spilled fuel from machine. DO NOT smoke.
5. Practice operation of machine with BLADES OFF to learn controls and develop skills.
6. Check the area to be mowed and remove all objects such as toys, wire, rocks, limbs and other objects that could cause injury if thrown by blade or interfere with mowing.
7. Evaluate the terrain to determine what accessories and attachments are needed to properly and safely perform the job. Only use accessories and attachments approved by SNAPPER
8. Keep people and pets out of mowing area. Immediately, STOP blades, STOP engine, and Stop machine if anyone enters the area.
9. DO NOT operate machine unless all shields, deflectors, switches, blade controls and other safety devices are in place and functioning properly.
10. Make sure all safety decals are clearly legible. Replace if damaged.



IMPORTANT SAFETY INSTRUCTIONS



PREPARATION

(Continued From Previous Page)

11. Protect yourself when mowing and wear appropriate clothing including safety glasses, long pants, ear protection, hardhat and substantial footwear with good traction. Long hair, loose clothing or jewelry may get tangled in moving parts.
12. Know how to STOP blades and engine quickly in preparation for emergencies.
13. Use extra care when loading or unloading the machine into a trailer or truck.
14. Check grass catcher components frequently for signs of wear or deterioration and replace as needed to prevent injury from thrown objects going through weak or worn spots.

OPERATION

1. DO NOT put hands or feet near or under rotating parts. Keep clear of the discharge area while the engine is running.
2. BEFORE STARTING ENGINE, blades must be OFF and Traction Levers LOCKED in the Traction Lock position.
3. Stop Blades when crossing gravel drive, walks, and under any conditions where thrown objects might be a hazard.
4. DO NOT raise deck with the blades running.
5. Mow only in daylight or good artificial light.
6. USE EXTRA CARE when approaching blind corners, shrubs, trees or other objects that may obscure vision.
7. DO NOT operate the machine while under the influence of alcohol or drugs.
8. After striking a foreign object or if the mower vibrates abnormally, STOP the blades and engine. Remove the key. Disconnect and secure the spark plug wire. Inspect the mower for any damage and repair the damage.
9. DO NOT operate machine near drop offs, ditches, embankments, washouts culverts, fences and protruding objects. STAY ALERT for holes and other hidden hazards. Tall grass can hide obstacles.
10. DO NOT operate machine on wet grass. Always be sure of your footing while operating machine, especially while backing up. Keep a firm grip on the handle. Walk: never run. Slipping and falling could cause injury.
11. DO NOT leave the machine with the engine running. STOP BLADES, STOP ENGINE and REMOVE KEY before leaving the operator position for any reason.

OPERATION

(Continued From Previous Column)

10. Before cleaning, repairing, or inspecting make certain blades, engine and all moving parts have STOPPED. Remove key and secure spark plug wire away from spark plug key to prevent accidental starting.
11. STOP MACHINE on level ground, engage parking brake (if equipped) and make sure engine and blades have stopped before leaving the operator's position for any reason including removing grass catcher or unclogging mower to prevent injury to hands or feet.
12. Blades must be OFF except when cutting grass. Set blades in highest position when mowing over rough ground.
13. Keep hands and feet away from rotating blades underneath deck.
14. DO NOT operate machine without entire grass catcher or guards in place. DO NOT point discharge at people, passing cars, windows or doors.
15. Slow down before turning.
16. Watch out for traffic when near or crossing roadways.
17. Move motion control levers SLOWLY to maintain control during speed and directional changes.
18. DO NOT operate engine in enclosed areas. Engine exhaust gases contain carbon monoxide, a deadly poison.

MAINTENANCE

1. Shut off fuel while storing or transporting. DO NOT store machine or fuel container inside where fumes may reach an open flame, spark or pilot light such as in a water heater, furnace, clothes dryer or other gas appliance. Allow engine to cool before storing machine in an enclosure. Store fuel container out of the reach of children in a well ventilated, unoccupied building.
2. Clean grass and debris from engine, mufflers, drives and cutting units to help prevent fires. Clean up fuel, oil and excess grease.
3. When draining fuel tank, drain fuel into an approved container outdoors and away from open flame.
4. Check brakes frequently (if equipped); adjust, repair or replace as needed.
5. Keep all bolts, nuts and screws properly tight. Check that all cotter pins are in proper position.
6. Always provide adequate ventilation when running engine. Exhaust gases contain carbon monoxide, an odorless and deadly poison.



IMPORTANT SAFETY INSTRUCTIONS



MAINTENANCE

(Continued From Previous Page)

7. Disconnect battery before performing maintenance or service. Cranking engine could cause injury. Disconnect negative (black) cable from battery first and positive (red) last. Reconnect positive first and negative last. Charge battery in an open well ventilated area, free from spark and flames. Unplug charger before connecting or disconnecting from battery. Wear protective clothing and insulated gloves.
8. Park machine on level ground. DO NOT work under machine without safety blocks.
9. Service engine and clean, adjust or repair only when engine and blades are stopped. Remove key. Remove spark plug wire(s) from spark plug(s) and secure wire(s) away from spark plug(s).
10. DO NOT change engine governor speed settings or overspeed engine. DO NOT make adjustments with the engine running.
11. Lubricate machine at intervals specified in manual to prevent controls from binding.
12. Mower blades are sharp and can cut. Wrap the blades or wear heavy leather gloves and use CAUTION when handling them. DO NOT straighten or weld blades, only replace them.
13. DO NOT test for spark by grounding spark plug next to spark plug hole; spark plug could ignite gas exiting engine.
14. Carefully release pressure from components with stored energy.
15. Have machine serviced by an authorized SNAPPER dealer at least once a year and have the dealer install any new safety devices. DO NOT allow untrained personnel to service the machine.
16. Use only genuine SNAPPER replacement parts to assure that original standards are maintained.

TABLE OF CONTENTS

IMPORTANT SAFETY INSTRUCTIONS.....	2-4
TABLE OF CONTENTS.....	5
SECTION 1 - FAMILIARIZATION.....	6
SECTION 2 - SAFETY MESSAGES & SYMBOLS	7-9
Controls	10
SECTION 3 - OPERATING INSTRUCTIONS.....	11-17
Before Operating	11
Stopping Machine	11
Pre-Start Checklist	11
Starting and Operating	11-14
Reverse Operation.....	14
Traction Lock Operation.....	15
Turning Mower.....	15
Mowing and Turning on Hillside.....	15
Cutting Height Adjustment (Fixed Decks)	16
Adjusting Caster Wheels	16
Adjusting Blade on Cutter Spindle	16
Adjusting Fixed Deck Attachment	17
SECTION 4 - TROUBLESHOOTING.....	18-19
Engine Troubleshooting	18
Mower Troubleshooting	18-19
Transmission Troubleshooting.....	19
Service & Lubrication.....	19
SECTION 5 - ADJUSTMENTS	20-21
Steering and Brakes.....	20
Traction Levers & Rods	20
Handle Height	21
Transmission Shift Lever Adjustment.....	21
SECTION 6 - POWER UNIT SERVICE	22
Replacement Parts	22
Transmission Parts & Service.....	22
General Transmission Servicing	22
Transmission/Lube	22
SECTION 7 - MOWER ATTACHMENT SERVICE	23-25
Transmission Belt Removal/Installation	23
Traction Belt Removal/Installation	23
Cutter Deck Belt Removal/Installation	23
Cutting Blade Service: Removal, Sharpening, Balancing & Replacement.....	24
Mower Spindles (Field Serviceable Spindles) Bearing Replacement	25
SECTION 8 – ELECTRICAL SCHEMATIC	26
WARRANTY.....	27
PRIMARY MAINTENANCE.....	28-31

SECTION 1 - FAMILIARIZATION

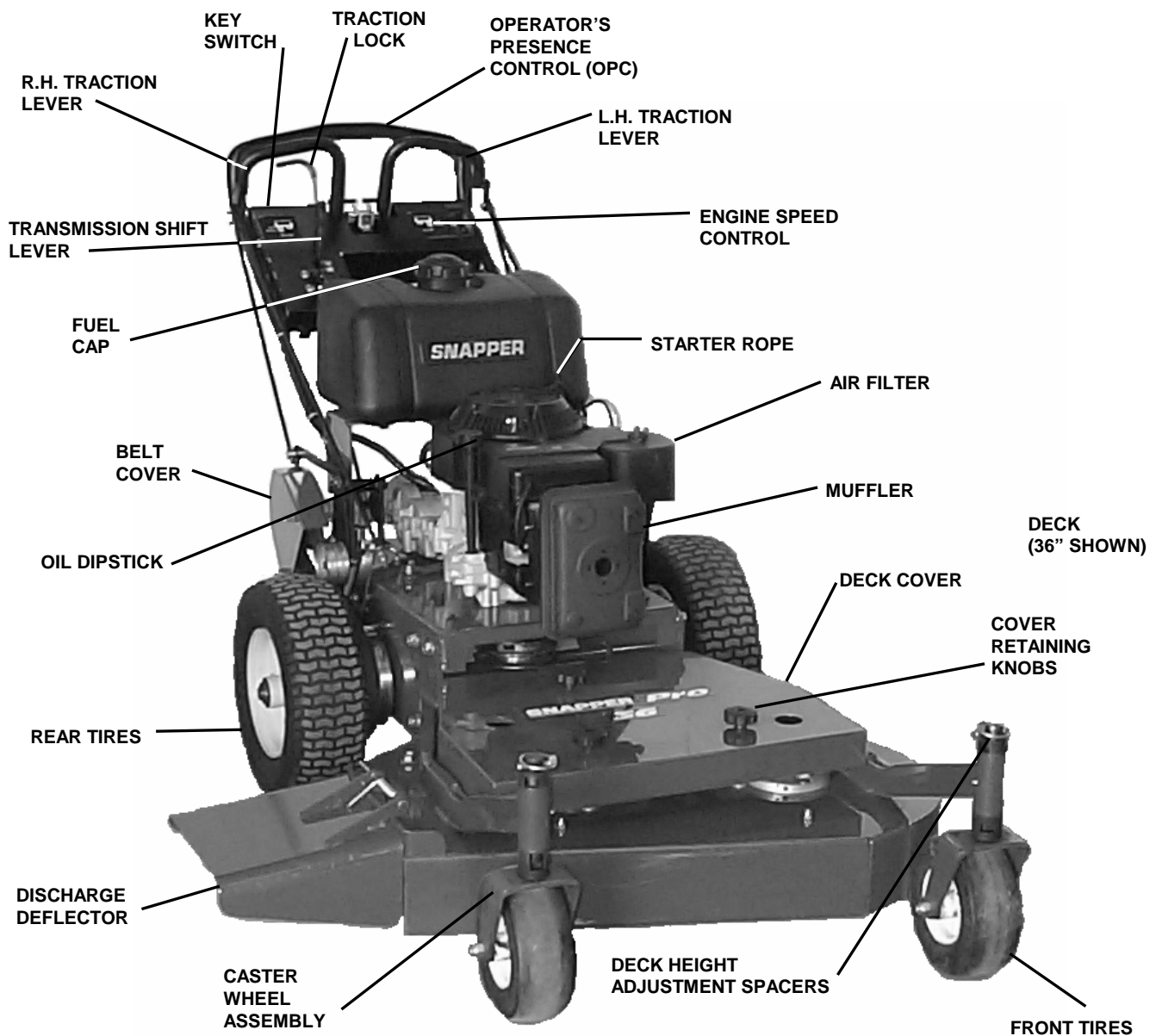

FIGURE 1.1

1.1 INTRODUCTION

This manual has been prepared for the operator's of the SNAPPER PRO GEAR WALK BEHIND MOWER. Its purpose, aside from recommending standard operating procedures and routine service requirements, is to promote SAFETY through the use of accepted operating practices. Read, Understand and Follow the IMPORTANT SAFETY INSTRUCTIONS on Pages 2 thru 4 of this manual and All SAFETY messages on the PRO GEAR WALK BEHIND MOWER and its attachments before operating. SNAPPER recommends returning the MACHINE to an authorized SNAPPER dealer annually for inspection and addition of any new devices which might upgrade the safety of the mower.

1.2 NOMENCLATURE

It is recommended that all operator's of this equipment become thoroughly familiar with the controls, components, and operation of this machine before operating. Specific details involving the engine are found in the separate engine owner's manual. Study these manuals before operating and keep both handy for future reference. For the nearest SNAPPER dealer in your area, check the yellow pages under the heading LAWN MOWERS. For engine parts and service, look for the engine manufacturer's dealers under the heading, ENGINES - gasoline.

SECTION 2 - SAFETY MESSAGES AND SYMBOLS

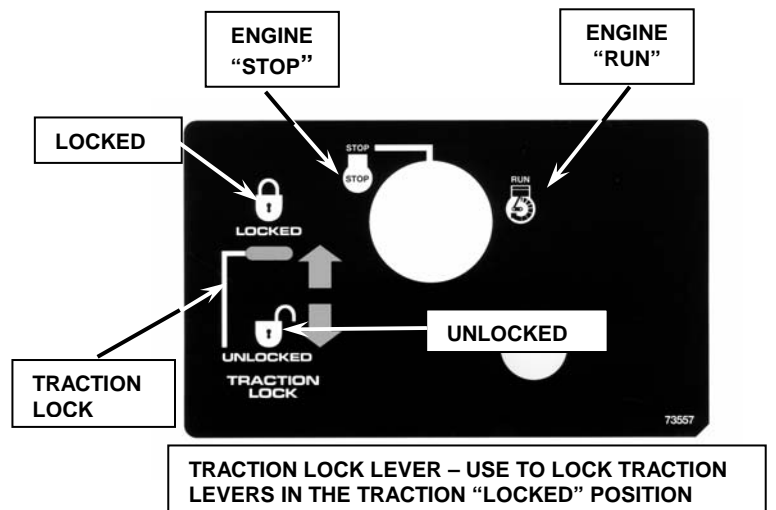
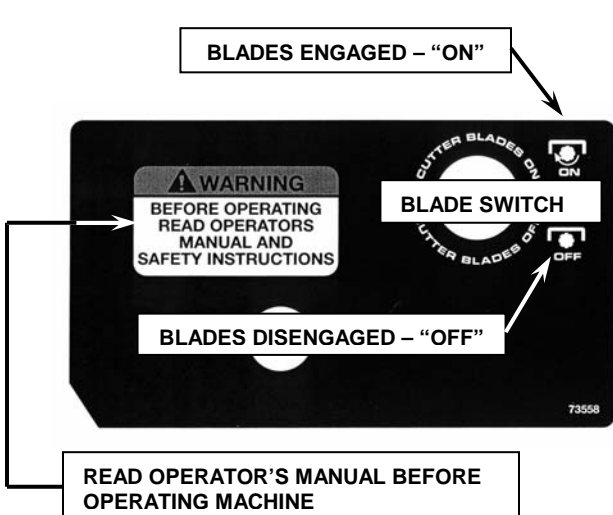
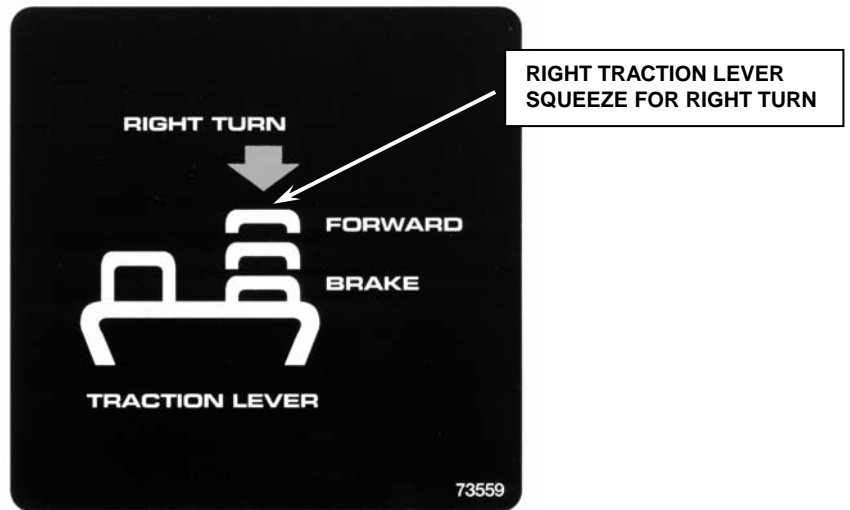
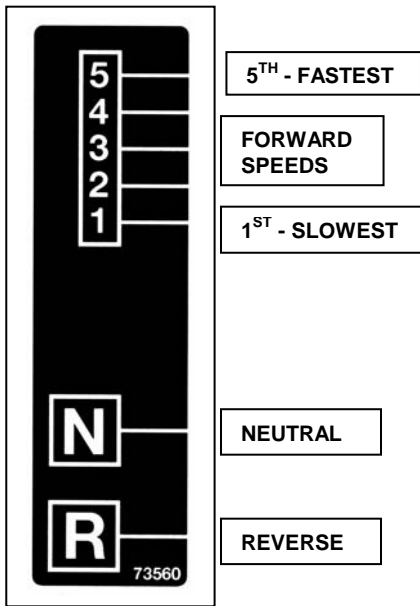
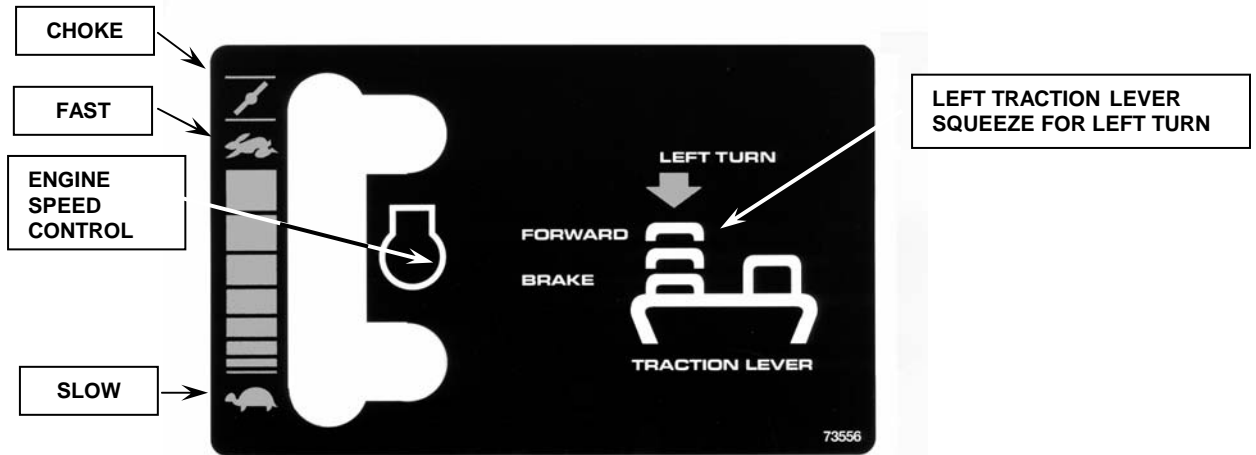

SECTION 2 - SAFETY MESSAGES AND SYMBOLS

WARNING

AVOID SERIOUS INJURY OR DEATH

READ, UNDERSTAND AND FOLLOW ALL INSTRUCTIONS AND WARNINGS IN OPERATORS MANUAL AND ON MACHINE.

- THIS MACHINE IS DESIGNED FOR PROFESSIONAL USERS. DO NOT OPERATE UNTIL THOROUGHLY TRAINED AND FAMILIAR WITH ALL CONTROLS AND PROPER USE OF THIS MACHINE.
- PRACTICE OPERATION WITH BLADES OFF IN OPEN FLAT AREA.
- DO NOT OPERATE WITHOUT GUARDS OR ENTIRE GRASS CATCHER IN PLACE.
- DO NOT BYPASS OR DISABLE ANY SAFETY DEVICES.
- OPERATOR PROTECTIVE EQUIPMENT REQUIRED: SAFETY GLASSES, LONG PANTS, AND SUBSTANTIAL FOOT WEAR.
- DO NOT LEAVE OPERATORS POSITION WITH ENGINE RUNNING. STOP BLADES, STOP ENGINE, REMOVE KEY.
- DO NOT REFUEL WITH ENGINE RUNNING OR HOT. ADD FUEL ONLY WHEN ENGINE IS COOL AND WITH MACHINE IN AN OPEN AREA.
- DO NOT ALLOW CHILDREN OR OTHERS IN MOWING AREA WHEN MACHINE IS OPERATED (EVEN WITH BLADES OFF).
- DO NOT PARK MACHINE ON SLOPES.
- DO NOT OPERATE BLADES WITH MACHINE IN REVERSE.

OPERATION

- BEFORE STARTING, CHECK THE FOLLOWING: BLADE CLUTCH SWITCH "OFF", TRANSMISSION SHIFT LEVER IN "NEUTRAL", TRACTION LEVERS LOCKED IN TRACTION LOCKED POSITION.
- SET THROTTLE TO HIGH SPEED. (CHOKE MAY BE REQUIRED). TURN KEY TO "RUN".
- START ENGINE.
- DEPRESS OPC SAFETY LEVER (S).
- TO MOW, FLIP BLADE CLUTCH SWITCH TO "ON".
- MOVE TRANSMISSION SHIFT LEVER TO A SLOW SPEED.
- SQUEEZE BOTH TRACTION LEVERS TO RELEASE TRACTION LOCK(S).
- SLOWLY RELEASE BOTH TRACTION LEVERS TO MOVE FORWARD.
- TO SHIFT INTO "REVERSE", STOP MACHINE, LOCK TRACTION LEVERS, IDLE ENGINE, SHIFT TO "REV". CAREFULLY RELEASE BOTH TRACTION LEVERS.

WARNING

TO AVOID SUDDEN AND UNEXPECTED TURNING, BOTH TRACTION LEVERS MUST BE MOVED THE SAME WAY WHEN STARTING OR STOPPING MACHINE MOTION.

STOPPING MOWER

- SQUEEZE BOTH TRACTION LEVERS TOWARDS HANDLE AND "SET" TRACTION LOCK(S).
 - SWITCH "OFF" BLADE CLUTCH SWITCH.
 - MOVE THROTTLE TO IDLE POSITION.
 - TURN KEY TO "STOP" POSITION.
 - REMOVE IGNITION KEY WHEN LEAVING MACHINE.
- TO OBTAIN OPERATOR'S MANUAL & SAFETY INSTRUCTIONS, CONTACT SNAPPER DEALER OR WRITE

SNAPPER POWER EQUIPMENT
P.O. BOX 777
MCDONOUGH, GA 30253, USA

73612

IMPORTANT SAFETY AND OPERATING INSTRUCTIONS

SECTION 2 – SAFETY MESSAGES AND SYMBOLS



DANGER! ROTATING BLADES. KEEP HANDS AND FEET AWAY.
KEEP CHILDREN AND OTHERS OUT OF THE MOWING AREA



DANGER! ROTATING BLADES

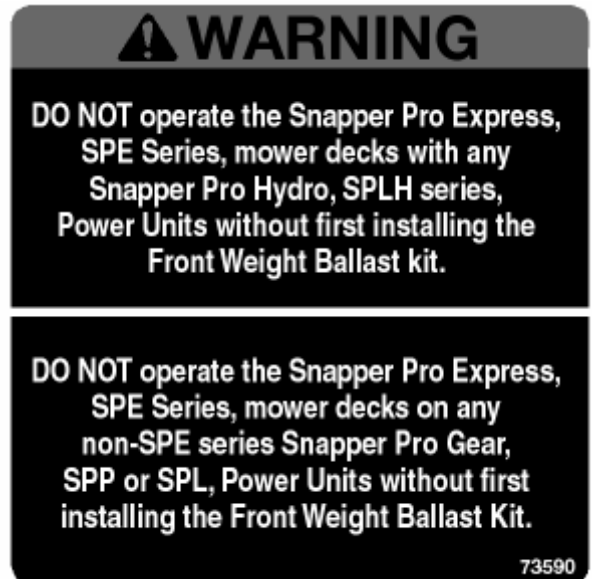

SECTION 2 - CONTROLS

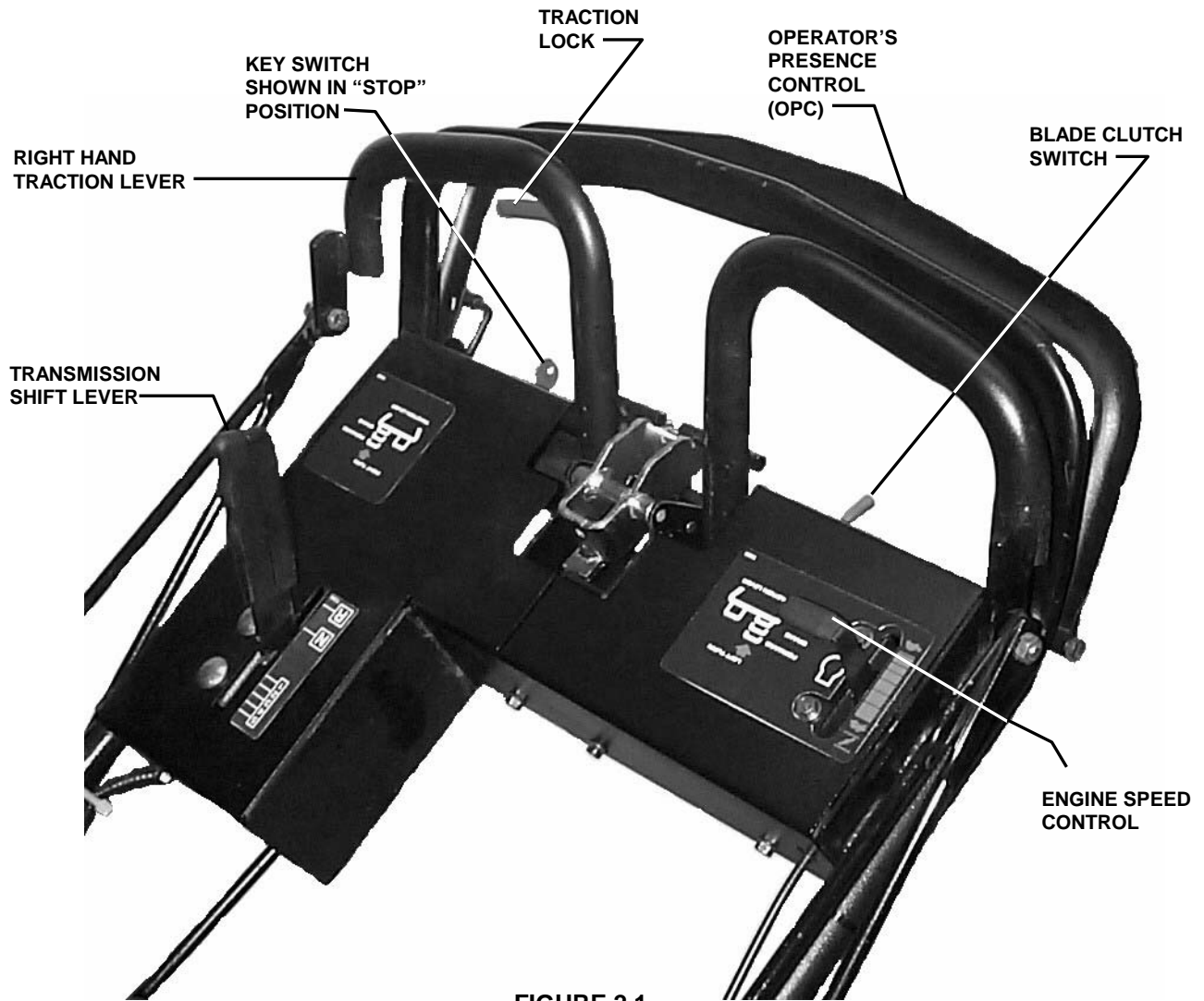

FIGURE 2.1

NOTE: TRACTION LOCK SHOWN IN THE TRACTION LEVER "LOCKED" POSITION



WARNING



To avoid sudden and unexpected turning, both Traction Levers must be moved the same way when starting or stopping machine motion.

SECTION 3 - OPERATING INSTRUCTIONS

3.1 BEFORE OPERATING

Be Thoroughly familiar with all controls and how to use them before operating the machine. Know beforehand how to **STOP** the Traction Wheel Drives, Mower Blades and Engine in preparation for possible emergencies.

3.2 STOPPING MACHINE

1. To **STOP** forward or reverse motion, firmly squeeze both Traction Levers towards the handle and hold. Using your right thumb, push Traction Lock forward to the "Locked" position and hold. See Figure 3.1.
2. Make sure that the Traction Lock has fully engaged both the right and left Traction Levers.
3. Release Traction Levers slowly and with caution. Remove thumb from Traction Lock.
4. Move Transmission Shift Lever to "Neutral".
5. Move Blade Clutch Switch down to the **OFF** position. See Figure 3.1.
6. Move Engine Speed Control Lever to **SLOW** (turtle) position. See Figure 3.1.
7. **STOP ENGINE** by turning Key Switch to "Stop" position. Remove key. See Figure 3.1.

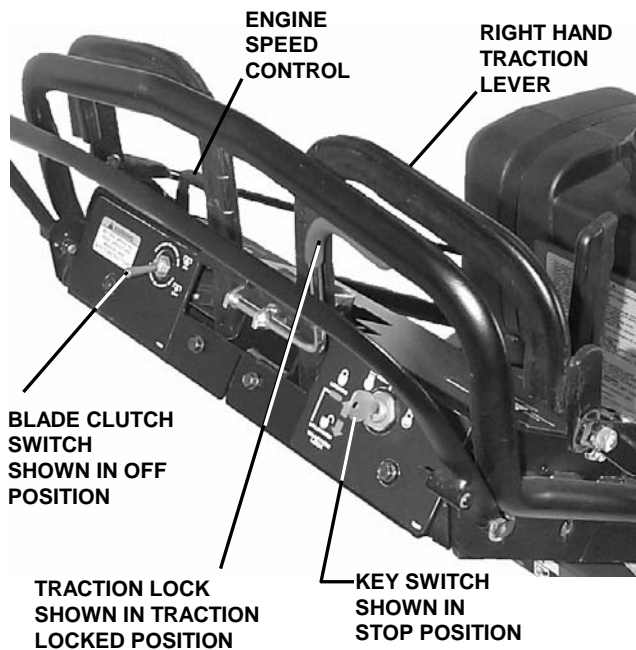



FIGURE 3.1

 WARNING 
When the Operator's Presence Control (OPC) is released, the machine will continue to operate a few feet. DO NOT use this Operator's Presence Control (OPC) to routinely stop the machine.

3.3 PRE-START CHECK LIST

Make the following checks and perform the services as required before each start-up:

1. If required, make cutting height adjustments. Refer to Section "CUTTING HEIGHT ADJUSTMENT"..
2. Check tires and adjust inflation pressure as needed. Inflate front tires to 25 psi and rear tires to 12-15 psi.
3. Check Guards, Deflector, and Belt Covers to make sure all are in place and secure.
4. Check Condition of Cutter Deck Belt(s). If damaged, replace with original part. Refer to Section "CUTTER DECK BELT REMOVAL".
5. Inspect condition of cutter blades. If worn or damaged, replace before operating machine. Refer to Section "Cutter Blade Service".
6. Clean Interior and Exterior Surfaces of cutting deck and clean Engine of any accumulation of dirt, grass, oil, etc. Keep Engine air intake screens and cooling fins clear at all times.
7. Check Engine Oil and add oil as needed to bring level up to (but not over) the **FULL** mark. (Refer to Engine manual for oil specifications).
8. Add Fuel to tank after pushing the Mower outside where **fumes** can be dissipated. Make sure Fuel Tank Cap is tightened after refueling. (Refer to Engine manual for fuel specifications).

NOTE: DO NOT add fuel while engine is running or hot. Use fresh, clean, lead-free gasoline. DO NOT use gasoline that has been stored for long periods. Leaded gasoline or gasohol is NOT recommended.

3.4 STARTING & OPERATING

3.4.1. ENGINE: START ENGINE AS FOLLOWS:

1. Turn Fuel Shut-Off Valve to the **OPEN** position. See Figure 3.2.
2. Pull both Traction Levers firmly rearward towards the handle. Using the Traction Lock Lever, lock both Traction Levers in the Traction "Locked" position. Make sure that the Traction Lock has fully engaged both Traction Levers. See Figure 3.2.
3. Place Transmission Shift Lever in **NEUTRAL (N)** position. See Figure 3.3
4. Move Blade Clutch Switch down to the **OFF** position. See Figure 3.1.
5. Move Engine Speed Control Lever to the **CHOKE** position. See Figure 3.4.
6. Turn Key Switch to **RUN** position.

SECTION 3 - OPERATING INSTRUCTIONS

3.4 STARTING & OPERATING -

(Continued from previous page)

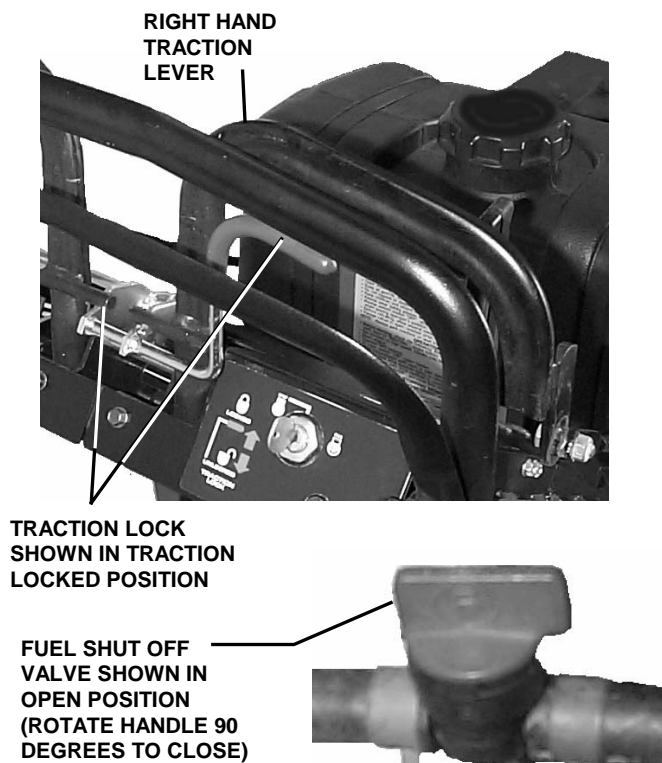

FIGURE 3.2



FIGURE 3.3

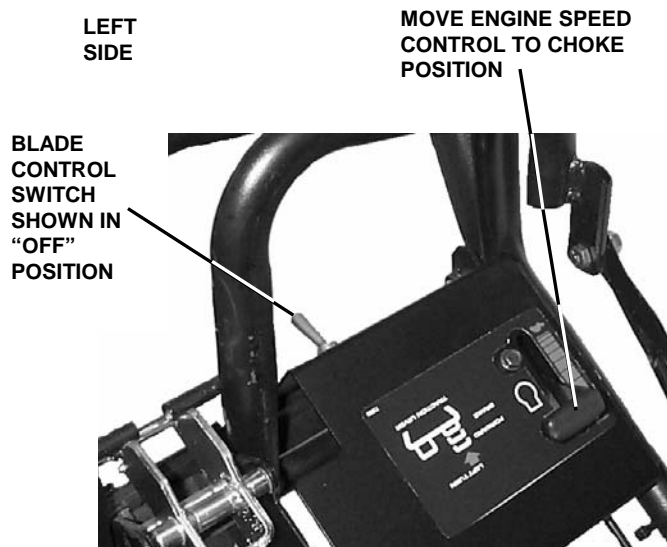

FIGURE 3.4

IMPORTANT: DO NOT jerk the engine recoil starter handle or allow it to snap back.

NOTE: Engine will not start unless the transmission is in NEUTRAL position and Blade Clutch Switch is in OFF position.

7. Pull Engine Recoil Starter Handle. If the engine starts, move engine speed control back to the **FAST** position. If the engine made a firing sound but did not start, move engine speed control back to the **FAST** position and pull the engine recoil starter again and the engine should start.
8. Depress Operator's Presence Control (OPC) against handle. See Figure 3.5.
9. Place Transmission Shift Lever in No. 1 position (first gear). See Figure 3.3.
10. To engage the blades, pull out and up on Blade Clutch Switch moving it to **ON** position. See Figure 3.4.

NOTE: Releasing the Operator's Presence Control (OPC) while Transmission is in **GEAR** and/or Blades **ON**, will Ground the Ignition Circuit and cause the Engine to **STOP**, allowing the **Machine to travel only a few feet** before coming to a complete **STOP**.

SECTION 3 - OPERATING INSTRUCTIONS

3.4 STARTING & OPERATING - (Continued from previous page)

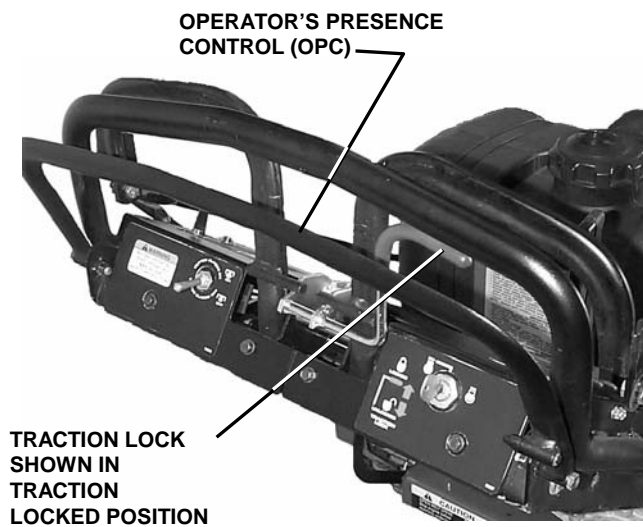

FIGURE 3.5

- The machine is **TURNED** by squeezing either the left or right Traction Lever. Squeezing the control declutches the drive belt and applies a brake. Turn left by squeezing the left Traction Lever or turn right by squeezing the right Traction Lever. See Figure 3.9. The more pressure applied while squeezing the traction lever, the sharper the machine will turn.
- TO STOP MACHINE** firmly squeeze both Traction Levers towards the handle to **STOP** forward or reverse motion. Using your right thumb, push Traction Lock forward to the "Locked" position and hold. See Figure 3.2 and 3.8.
- Make sure that the Traction Lock has fully engaged both the right and left Traction Levers.
- Release Traction Levers slowly and with caution. Remove thumb from Traction Lock.
- Pull the Blade Clutch Switch rearward to the **OFF** position. See Figure 3.6.

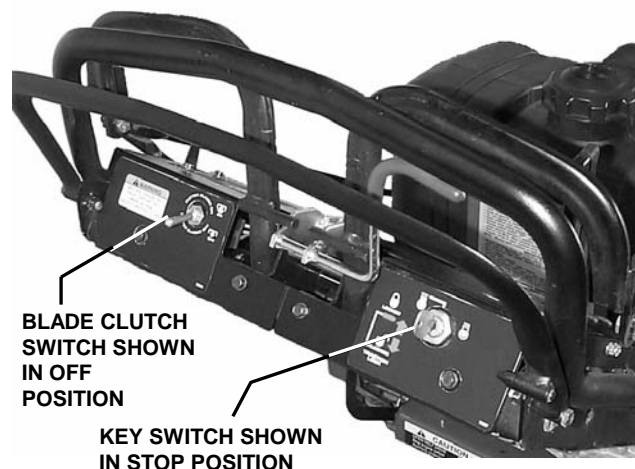

FIGURE 3.6

WARNING
Start mowing with a slow ground speed and gradually increase speed to determine the most comfortable travel speed.

- To **START MACHINE MOVEMENT**, squeeze both Traction Levers firmly against the handlebar allowing the Traction Lock to move to the "Unlocked" position. Using caution, slowly and simultaneously allow both Traction Levers to move forward. The machine will begin to move forward.

IMPORTANT: Always **STOP** machine movement and "Lock" both Traction Levers before changing to a different ground speed. Transmission damage could result if ground speed is changed when machine is moving.

WARNING
During initial training time with machine, it is advised that the operator(s) practice all mower movements while operating the mower with the transmission shift lever in no. 1 (first gear) travel speed position and blade clutch switch in off position! **DO NOT** make sharp turns at high speeds!

- Place the Transmission Shift Lever into the NEUTRAL (N) position.
- Move engine speed control to slow (Turtle) position.
- Stop engine. Turn key switch to "Stop" position. Remove key. See Figure 3.6.

WARNING
DO NOT leave machine with engine running. Stop engine. Stop blades. Lock Traction Levers. Remove key. **DO NOT** park machine on slopes.

(Continued on next page)

SECTION 3 - OPERATING INSTRUCTIONS

WARNING

DO NOT operate blades in reverse. Stop blades. **LOOK** and **SEE** behind and down for children, pets and hazards before and while backing. Engine speed must be set to **SLOW** before operating in reverse.

3.5 REVERSE OPERATION

1. To **REVERSE DIRECTION OF MACHINE**, STOP Machine and **lock** Traction Levers in the Traction Locked position.
2. Pull Blade Clutch Switch rearward to the “**OFF**” position. Move Engine Speed Control Lever to “**IDLE**”.
3. Move Transmission Shift Lever to **REVERSE (R)** position.
4. Hold Operator’s Presence Control (OPC) against handlebar.
5. To **START MACHINE MOVEMENT**, simultaneously squeeze both Traction Levers firmly against the handle allowing the Traction Lock to move to the “**Unlocked**” position. See Figure 3.7.
6. Using caution, simultaneously and slowly release both Traction Levers, allowing machine to start rearward movement.
7. **TO STOP MACHINE**, Simultaneously squeeze both Traction Levers firmly against the handle while pushing the Traction Lock forward. Lock both Traction Levers in the Traction Locked position.

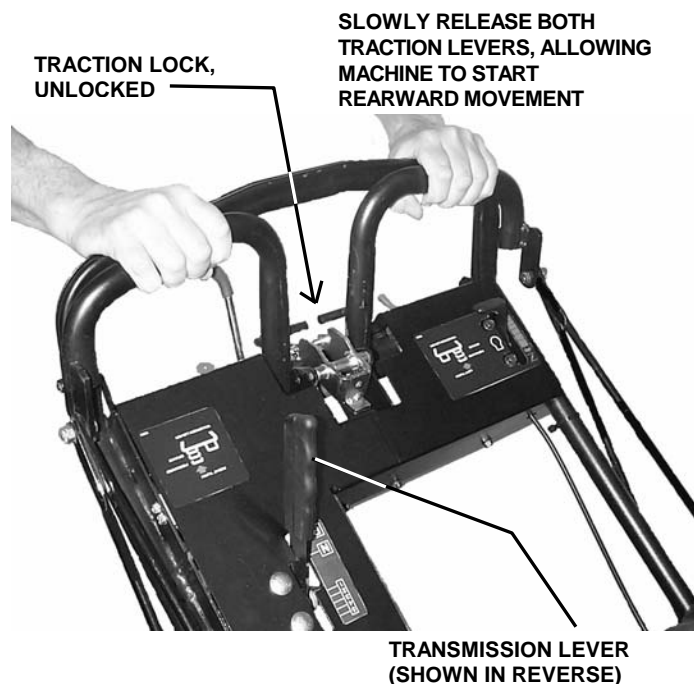

FIGURE 3.7

SECTION 3 - OPERATING INSTRUCTIONS

WARNING
Brakes require maintenance. Inspect for proper operation before operating machine. Refer to Section "ADJUSTMENTS, STEERING AND BRAKES".

3.6 TRACTION LOCK OPERATION -

1. To "Lock" the Traction Levers, simultaneously squeeze both Traction Levers toward the handle.
2. Using right thumb, push Traction Lock forward to the "Locked" position and hold. Make sure that the Traction Lock has fully engaged both Traction Levers. See Figure 3.2 and 3.8.
3. Carefully and slowly release both Traction Levers. Remove thumb from Traction Lock.
4. To "Unlock" the Traction Levers, simultaneously squeeze both Traction Levers toward the handle. The Traction Lock will move to the "Unlocked" position.

RIGHT THUMB PUSHING
TRACTION LOCK LEVER
FORWARD TO LOCK



FIGURE 3.8

WARNING
Machine should always be in forward motion before attempting a turn. DO NOT attempt a turn from a stopped position.

3.7 TURNING MOWER GRADUAL RIGHT & LEFT HAND TURN

IMPORTANT: Squeezing the right or left traction lever applies the brake to the right or left wheel. The brake turns the machine right or left.

1. With machine in Forward motion gradually squeeze the right hand traction lever. The machine will turn to the right.

2. With machine in Forward motion gradually squeeze the left hand traction lever. The machine will turn to the left.

TRACTION LEVER POSITION



FIGURE 3.9

3.8 MOWING AND TURNING ON HILLSIDES

1. Always mow hillsides starting at bottom of hill. Mow across slopes, never up and down. Exercise caution when changing directions on slopes. **DO NOT mow steep slopes!**

WARNING
DO NOT mow on steep slopes. DO NOT use with any type rider attachment on slopes. DO NOT park machine on slopes.

2. Hillside mowing is accomplished by squeezing Traction Lever on the **UPHILL SIDE** of machine. This helps reduce side slipping of mower.
3. When turning mower on hillsides, always turn toward the **UPHILL SIDE** of mower for better control and balance.

SECTION 3 - OPERATING INSTRUCTIONS

3.9 CUTTING HEIGHT ADJUSTMENT

(Fixed Decks)

Mower has three methods of adjusting cutting height:

1. Moving position of BLADE on cutter spindle.
2. Moving position of CASTER WHEEL on support.
3. Moving position of MOWER DECK on power unit.

WARNING

DO NOT attempt any maintenance, adjustments or service with the engine running. Stop engine. Stop blades. Lock Traction Levers. Remove key. Disconnect spark plug wires from spark plugs and secure wires away from spark plugs. Engine and components are HOT. Avoid serious burns by allowing all parts to cool before working on machine.

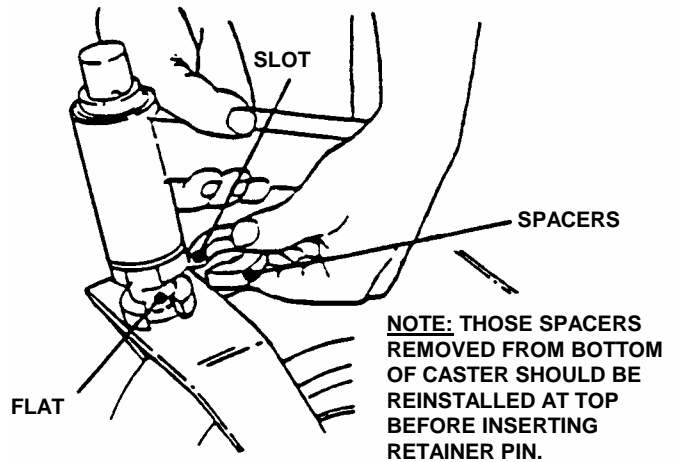

FIGURE 3.11

3.10. ADJUSTING CASTER WHEELS

The Caster Wheel Assembly has four (4) 1/2" and one (1) 1/4" thick spacer. The 1/4" thick spacer always stays on the stop side of the caster support tube. The 1/2" thick spacers are used to adjust the cutting height. When placed above or below Caster Support Tube, they raise or lower cutting height in 1/2" increments, thus providing a "Quick-Adjust" method. The deck mounting has to be changed to correspond to the caster repositioning. Refer to Section, "ADJUSTING FIXED DECK ATTACHMENT".

1. Remove Retainer Pin from Caster Shaft. See Figure 3.10.

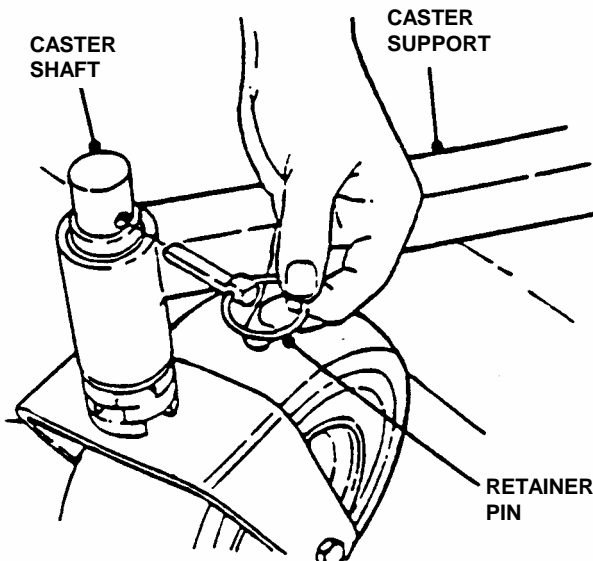

FIGURE 3.10

2. Lift Caster Support while adding or removing bottom spacer. See Figure 3.11.

NOTE: Remove (or add) spacers by rotating slots to align with flat area on caster shaft.

3.11 ADJUSTING BLADE ON CUTTER SPINDLE

To change cutting height of Blades, move the Spacers from under the Cutter Housing to above the Cutter Housing Pulley. Each Spacer moved above the Cutter Housing Pulley will provide an additional 1/4" of cutting height. **DO NOT** put any Spacers below Blade. See Figure 3.12.

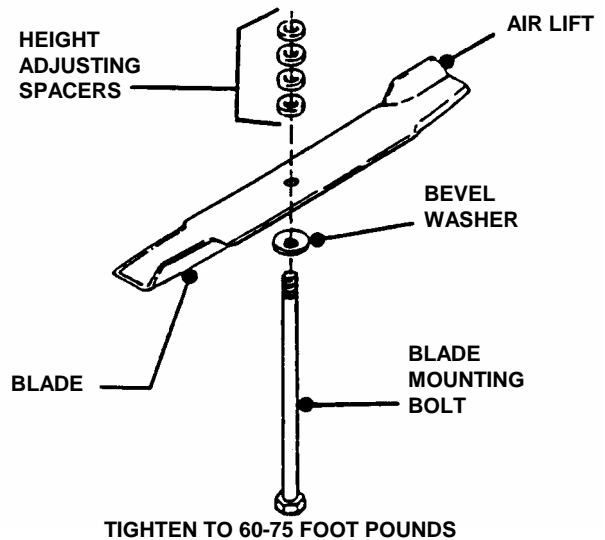

FIGURE 3.12

NOTE: Changing cutting height of blades does not change the deck ground clearance. If an undesirable cutting pattern results, then cutting height adjustment must be made by adjusting mower deck height and caster wheels.

Install Blades (Air Lift Up) with retaining hardware as shown below and tighten to 60 to 75 ft. lbs. of torque. See Figure 3.13.

(Continued on Next Page)

SECTION 3 - OPERATING INSTRUCTIONS

3.11 ADJUSTING BLADE ON CUTTER SPINDLE (Continued)

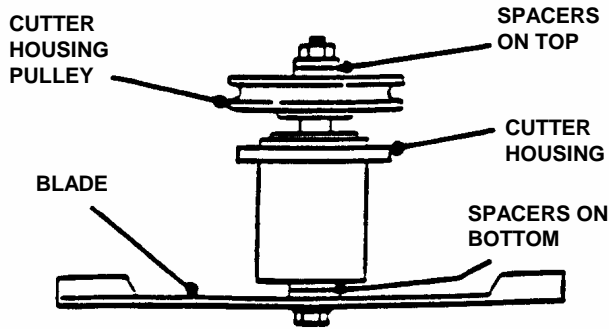

FIGURE 3.13

3.12 ADJUSTING FIXED DECK ATTACHMENT

The mower deck has four different positions for attaching it to the power unit. The lowest setting provides a cutting height range of 1-1/2" to 2-1/2", the middle low cut is 2-1/4" to 3-1/4", the middle high cut is 3" to 4", and highest cut is 3-3/4" to 4-3/4". Make sure the spacers on the caster wheels are moved up or down as shown to correspond with the bolt positions to keep deck level. Once a desired cutting height is reached, attach the mower deck to the power unit by installing 3 bolts on each side in selected height of cut holes. Tighten bolts to 70 to 80 foot pounds torque. See Figures 3.14 A-D.

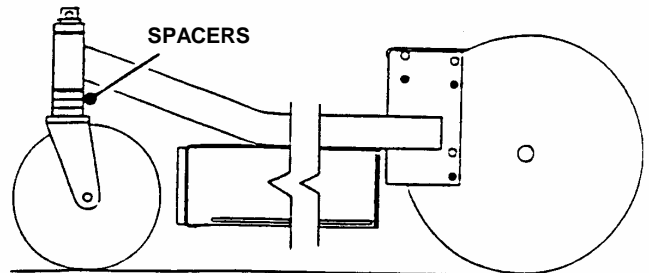

FIGURE 3.14C: MIDDLE HIGH CUT 3" TO 4"

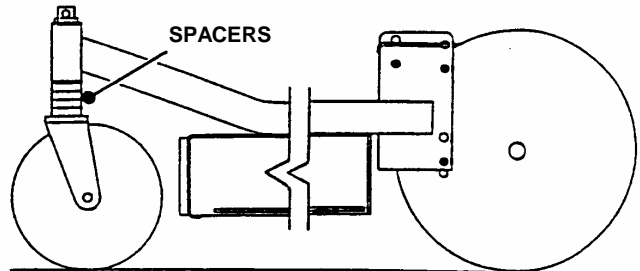

FIGURE 3.14D: HIGH CUT 3-3/4" TO 4-3/4"

FIGURES 3.14C-D

SIDE PROFILE OF UNIT

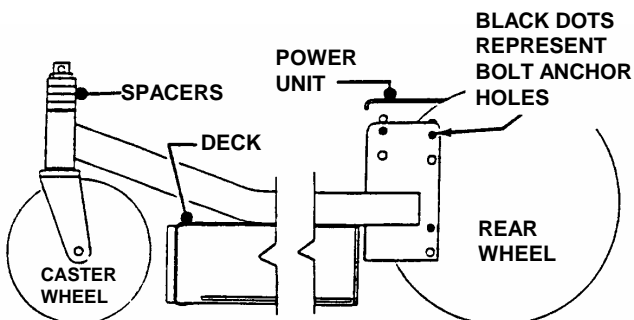

FIGURE 3.14A: LOW CUT 1-1/2" TO 2-1/2"

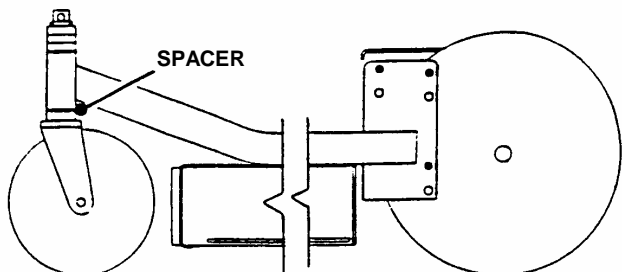

FIGURE 3.14B: MIDDLE LOW CUT 2-1/4" TO 3-1/4"

FIGURES 3.14A-B

SECTION 4 - TROUBLESHOOTING

ENGINE TROUBLESHOOTING

SYMPTOM	PROBLEM	SOLUTION
Engine does not start	Key OFF	Turn Key to Run.
	Fuel Tank empty.	Fill Fuel Tank.
	Fuel Shut-Off Closed.	Open Fuel Shut-Off.
	Engine Throttle Control not at FAST (Rabbit) position.	Put Engine Throttle Control to FAST
	Choke NOT closed.	Put Throttle Control in CHOKE position. Check choke adjustment.
	Spark Plug Wire loose or disconnected.	Connect Spark Plug Wire.
	Operator Presence Control (OPC) Switch out of adjustment	Adjust Switch
	Blade Clutch Switch in ON position.	Pull Blade Clutch Lever to OFF position.
	Spark Plug bad.	Install new Spark Plug.
	Dirty Air Filter.	Clean Air Filter.
	Transmission not in NEUTRAL.	Shift Transmission Lever to NEUTRAL.
Engine Starts Hard or Loses Power.	Dirt or water in Fuel Tank.	Drain and clean Fuel Tank. Fill with fresh Fuel.
	Vent in Gas Cap plugged.	Clean Vent or install new Gas Cap.
	Air Filter dirty.	Clean or install new Air Filter.
	Spark Plug not gapped correctly.	Check and set Spark Plug gap.
	Spark Plug bad.	Install new Spark Plug.
Engine Runs Erratically.	Spark Plug bad.	Install new Spark Plug.
	Spark Plug not gapped correctly.	Clean and set Spark Plug gap.
	Fuel Filter plugged or dirty.	Replace Fuel Filter.
Engine Idles Poorly.	Dirty Air Filter.	Clean or replace Filter.
	Fuel Filter plugged	Replace Fuel Filter.
Engine Overheats.	Engine Oil low in Crankcase.	Add Oil.
	Engine Cooling Fins clogged	Clean Engine Cooling Fins.
Machine Vibrates Excessive.	Blade Mounting Bolts loose.	Tighten Blade Mounting Bolts.
	Blade out of Balance.	Sharpen and balance Blade.
	Engine Mounting Bolts loose.	Tighten Mounting Bolts.
	Damaged or Severed Belt.	Replace Belt
Engine Dies.	Mowing grass too tall.	Adjust cutting height.
	Mowing too fast.	Reduce travel speed.

MOWER TROUBLESHOOTING

SYMPTOM	PROBLEM	SOLUTION
Mower does not move when Traction Levers released	Transmission in neutral.	Select Gear
	Traction Control Rod adjustment.	Adjust Rod
	Engine to Transmission Belt Damaged or Broken.	Replace Belt
	Idler Spring Damaged or Broken	Replace Spring
Mower does not track straight.	Slipping or broken Traction Belt.	Adjust or replace Belt.
	Tire pressure in both Traction Wheels not the same.	Adjust air pressure.
Blades DO NOT engage.	Belt slipping or broken.	Replace or adjust Belt.
	Clutch does not engage.	Check Electrical Connections & Clutch
Mower mows unevenly.	Travel speed too fast.	Reduce ground speed.
	Operator making mower turn corner too fast.	Reduce ground speed.
	Rough terrain.	Change mowing pattern.
	Unequal number of Blade Spacers on Cutter Shafts or Caster Wheels.	Install equal number of Spacers.
	Low Or No Air Pressure in Tires	Fill Tires with Correct Air Pressure
	Dull Blades	Sharpen Blades or Install new Blades

SECTION 4 - TROUBLESHOOTING

MOWER TROUBLESHOOTING (Continued)

SYMPTOM	PROBLEM	SOLUTION
Mower not cutting full width.	Broken or slipping Blade Belt. Dull, Damaged or Worn Blades	Replace Belt. Check idler and spring. Sharpen Blades or Install new Blades
Discharge	Grass wet.	Let Grass dry.
Deflector Becomes Obstructed	Mower too low. Engine overloaded.	Raise cutting height Run Engine at full Throttle and reduce travel speed.

TRANSMISSION TROUBLESHOOTING

SYMPTOM	PROBLEM	SOLUTION
Unit is Noisy.	Gearing is overly noisy - chatter, etc. Worn Gears. Worn Bearings - mainly input Shaft Ball Bearing.	Return to Authorized Snapper Dealer
Unit Jumps Out of Gear	Teeth of Gears are worn beyond tolerances. Spring in Shifter Fork weak or broken.	

SERVICE & LUBRICATION

HOURS	PROCEDURE	COMMENTS
BREAK-IN	Check all Grease Points and add if necessary Check all Fasteners for proper tightness. Change Engine Oil and Filter at 5 hours.	(See Engine Manual)
DAILY	Check Engine Oil. Clean Air Filter. Clean Air Intake Screen. Remove Debris from under Belt Cover. Sharpen Cutter Blades. Grease Cutter Spindle Bearings. Inspect Interlock Switches for Damage. Inspect Belts for Wear or Damage. Inspect brakes.	Change Oil if extreme dusty conditions. More often if needed. More often if needed. More often if needed. Tighten to 60-75 Ft.-Lbs. Use Chevron SRI Grease or equal. (NLGI No. 2) Replace if Needed. Replace if Needed. Adjust for proper steering / stopping.
WEEKLY	Check Tire Pressure. Check Safety Interlock System. Lube Traction (Drive) Levers. Inspect Traction Lock for Wear. Change Engine Oil and Filter. Replace Air Filter. Grease Caster Wheel Bearings. Grease Caster Support Arms. Grease Traction Wheels. Grease Idler Arm Pivots on Cutter Deck. Fuel Filter. Grease Traction Idler Pulley (Located on the Underside of Power Unit).	Add or Adjust as required. Inspect OPC Switch for proper Operation. One Shot General Purpose Grease. Replace if Worn. More often if needed. More often if needed. General Purpose Grease. General Purpose Grease. General Purpose Grease. General Purpose Grease. Replace with SNAPPER P.N. 1-4359 General Purpose Grease.
MONTHLY	Clean and Adjust Spark Plugs. Lube Controls and Linkages.	(See Engine Manual) Use Medium Duty Oil.

SECTION 5 - ADJUSTMENTS

5.1 STEERING/BRAKES

If machine is not as responsive as desired when either Traction Lever is squeezed, one or both brakes should be adjusted as follows:

1. Operate mower on level terrain with Transmission Shift Lever in No. 1 position. Determine which brake requires adjustment.
2. Stop engine, remove the key from switch and disconnect spark plug wire from spark plug. Secure wire away from plug.
3. Turn nut clockwise to increase brake tension. See Figure 5.1.

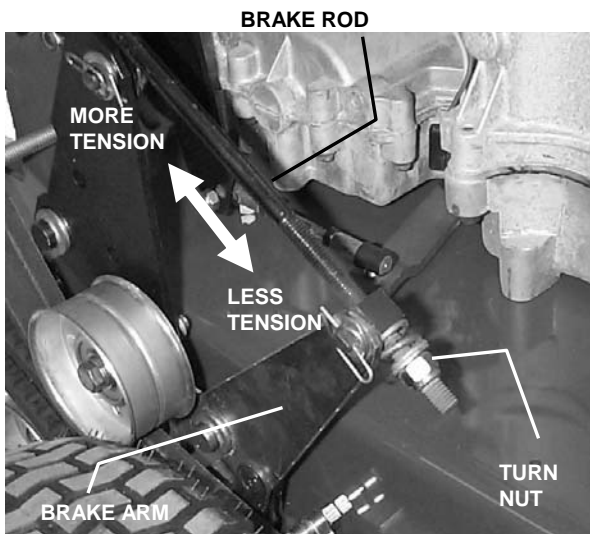

FIGURE 5.1

4. Place spark plug wire onto spark plug. Start engine and operate mower with transmission in the No. 1 position to check for proper adjustment. If further adjustment is required, repeat all steps above.

5.2 TRACTION LEVERS/RODS

If the Traction Wheel Drive Belts become slack or new belts have been installed, it will be necessary to adjust the Traction Levers as follows:

1. Move the machine to a smooth, level surface. Stop engine and remove key.
2. Remove two wing nuts from each right and left traction belt covers and remove covers.
3. Disconnect Brake Rod Swivels from right and left Brake Arms. See Figure 5.1.
4. Check for clearance between the Idler Arm and the upper traction belt cover stud. Squeeze the Traction Lever firmly against the handle. When properly adjusted the Idler Arm will just touch the stud when the Traction Lever touches the handle. There should be no gap and no interference between the arm and the stud. See Figure 5.2.

5. If adjustment is required use the threaded swivel on the Traction Rods. To reduce the gap, turn the swivel clockwise.

IMPORTANT! Traction Levers/Rod must be adjusted correctly to insure proper function of the traction belt and Traction Levers

6. Turn Traction Rod swivel one turn and recheck gap. Repeat until there is no gap between the arm and the stud.
7. Perform adjustment procedure on both right and left Traction Levers
8. Install belt covers. Tighten wing nuts securely.
9. Attach Brake Rod Swivels to right and left Brake Arms. Carefully secure with the Locking Hair Pins
10. Operate machine. Verify Traction Levers and Traction Belts function properly.

NOTE: It may be necessary to adjust the Traction Brakes after adjustment of the Traction Levers is complete. Refer to Section "ADJUSTMENTS - Steering/Brakes".

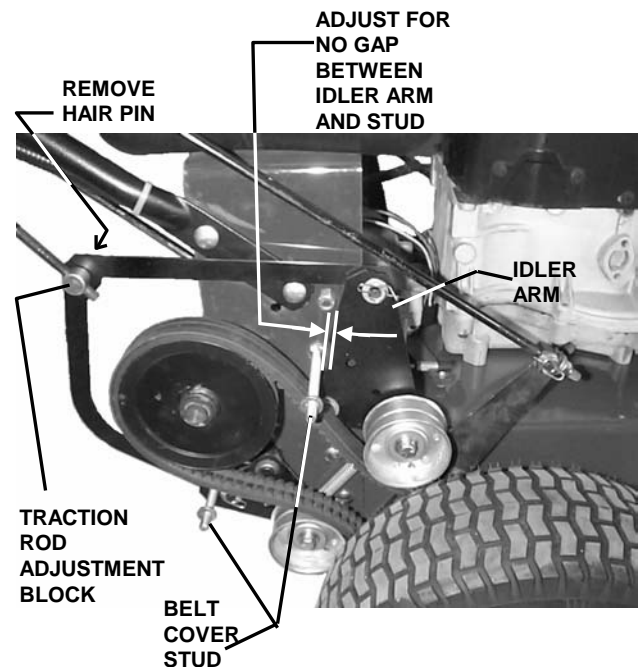

FIGURE 5.2

WARNING
DO NOT attempt to operate machine without belt cover and studs secured into the proper position.

SECTION 5 - ADJUSTMENTS

5.3 HANDLE HEIGHT

The operator handle can be adjusted for operator comfort as follows:

1. Loosen the upper carriage bolt and nut on both left and right lower handles. See Figure 5.3.
2. Remove lower carriage bolt and nut from both left and right handles.
3. Raise or lower handlebar to desired height. See Figure 5.3.
4. Align handle with one of the adjustment holes in the tank support bracket and insert the carriage bolt. See Figure 5.3.
5. Verify that the handle is still at desired height. Using nuts removed in Step 2, tighten both lower carriage bolts securely.
6. Securely tighten both upper carriage bolts and nuts.
7. The Traction Levers will require adjustment after the handle height has been adjusted. Refer to Section "ADJUSTMENTS – Traction Levers/Rods".
8. The Transmission Shift Lever linkage will require adjustment after the handle height has been adjusted. Refer to Section "ADJUSTMENTS – Transmission Shift Lever".

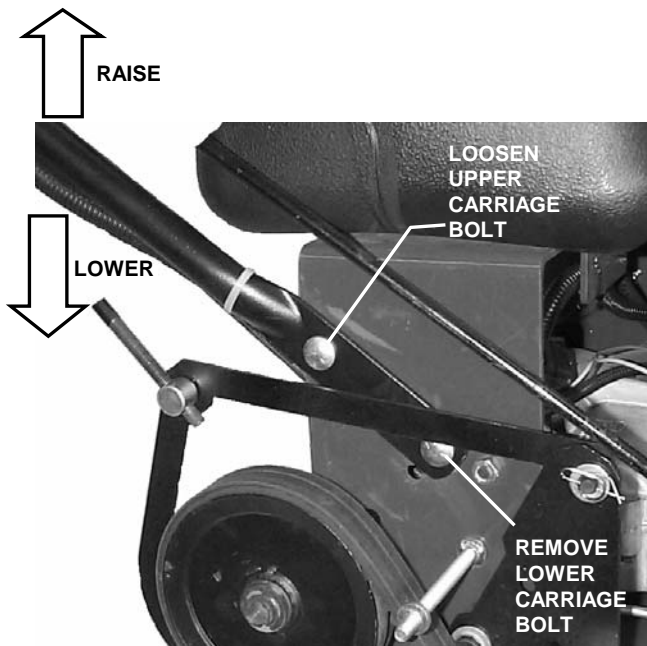

FIGURE 5.3

5.4 TRANSMISSION SHIFT LEVER ADJUSTMENT

1. Disconnect the hair pin from shift rod that connects to the Transmission Shift lever. See Figure 5.4.
2. Move the Transmission Shift lever to the neutral position. Move the shift lever, located on the transmission, to the neutral position.
3. Rotate the shift rod clockwise or counter clockwise to allow the upper portion of shift rod to be inserted into the Transmission Shift lever without moving the

speed control lever or the transmission shift lever. Reinstall hair pin. See Figure 5.5.

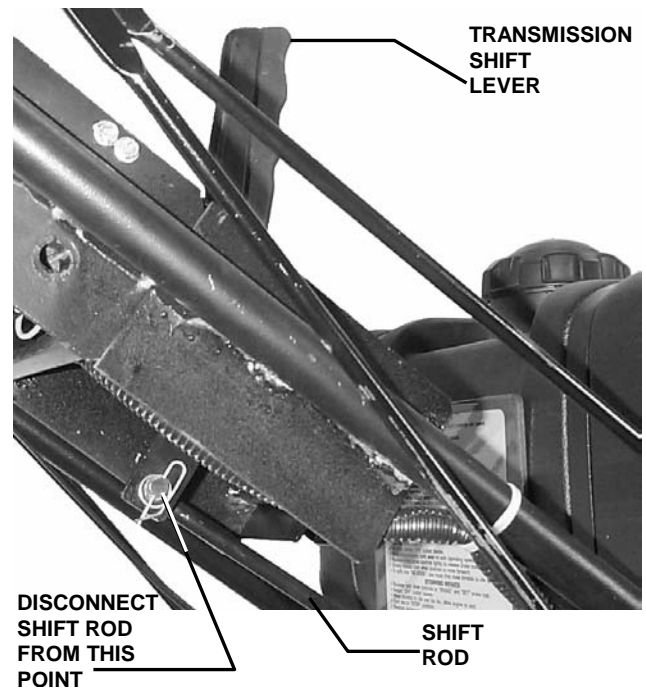

FIGURE 5.4

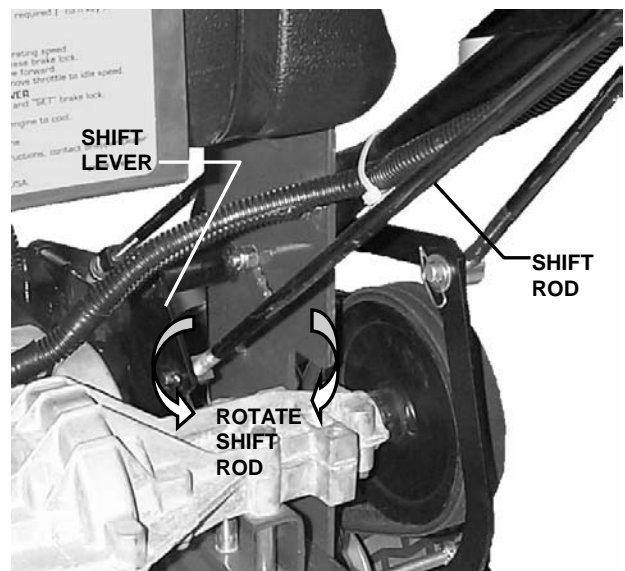

FIGURE 5.5

SECTION 6 - POWER UNIT SERVICE

6.1 REPLACEMENT PARTS

To retain the quality of your mower, use Genuine SNAPPER Replacement Parts only! Contact your local SNAPPER dealer for parts and service assistance. For the correct part or information for your mower, always mention Model and Serial Number of Power Unit and Mower Attachment. We recommend returning your mower to an authorized SNAPPER Dealer on a yearly basis for inspection and addition of any new devices which might upgrade the performance and safety of your mower. For the nearest SNAPPER Dealer, check the Yellow Pages under the heading LAWN MOWERS. For Engine Parts and Service, look for the Engine Manufacturer's Dealers under the heading ENGINES-Gasoline. For transmission parts and service, look for Tecumseh Engines & Transmission under Engines-Gasoline.

6.2.2. TRANSMISSION

The Peerless MST 205 Series Transmission requires no routine maintenance. Return machine to an authorized Snapper dealer for service, maintenance or problems.

6.2.3. TRANSMISSION LUBE

The transmission is permanently sealed. But, lubrication can be added if leakage should occur. The transmission case holds 16 ounces of 80W-90 gear oil. To Lubricate:

1. Remove transmission switch wire plug and remove the transmission interlock switch. Remove the fiber washer seated on switch.
2. Transmission oil is added through the switch hole.
3. Install new fiber washer, part number 2-9662, onto switch. Install switch into transmission and tighten securely. Attach wire plug onto switch.

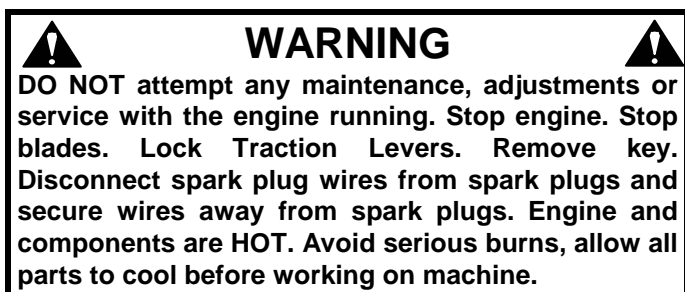

NOTE: All mid-size mowers should be tilted with engine carburetor side UP.

6.2 TRANSMISSION PARTS & SERVICE

For the nearest Peerless Transmission Dealer, check the Yellow Pages under heading, Engine-Gasoline. Look for Tecumseh Engine and Transmission under Engine-Gasoline.

6.2.1. GENERAL TRANSMISSION SERVICING

1. GENERAL TRANSMISSION SERVICING

Introduction:

The following service procedures should be understood and practiced whenever service must be performed on a Peerless MST 205 Series Transmission.

2. Before removing transmission from mower, make sure another part of machine is not causing problem, look for:
 - a) Loose drive belt.
 - b) Sheared keys in pulleys.
 - c) Oil saturated drive belts.
 - d) Transmission shift lever secure.

SECTION 7 - MOWER ATTACHMENT SERVICE

7.1 TRANSMISSION BELT REMOVAL/REPLACEMENT

Should it become necessary to replace the transmission drive belt, contact an authorized SNAPPER Dealer for service.

WARNING

DO NOT attempt any maintenance, adjustments or service with the engine running. Stop engine. Stop blades. Lock Traction Levers. Remove key. Disconnect spark plug wires from spark plugs and secure wires away from spark plugs. Engine and components are HOT. Avoid serious burns, allow all parts sufficient time to cool before working on machine.

1. Disconnect idler arm spring.
2. Remove existing belt. Replace with new belt, part no. 2-9118.
3. Reconnect idler arm spring. See Figure 7.1.

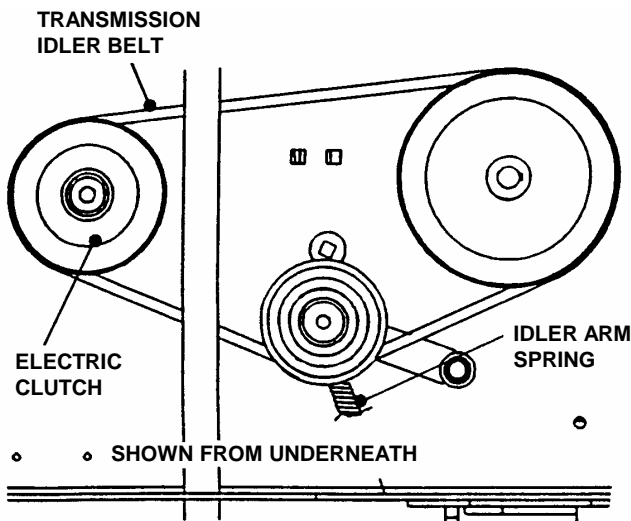

FIGURE 7.1

7.2 TRACTION BELT REMOVAL & REPLACEMENT

7.2.1. TRACTION BELT REMOVAL

1. **STOP ENGINE!** Remove two wing-nuts retaining belt cover. Remove belt cover. See Figure 7.2.
2. Remove Traction Belt from Wheel Pulley first by running Belt off as Wheel is turned. Remove belt from Transmission output Pulley next.
3. Lay Traction Belt flat on ground (around tire) and roll Mower Wheel over Traction Belt, removing Traction Belt from machine.

7.2.2. TRACTION BELT INSTALLATION

1. **STOP ENGINE!** Lay new Traction Belt, part number 4-6240, flat on ground in front of Traction Wheel. Roll Traction Wheel over Traction Belt until wheel is in middle of belt.

2. Place Traction Belt on Wheel Pulley followed by Transmission Output Pulley.
3. Reinstall belt cover and tighten two wing-nuts.
4. Adjust Traction Rod and Brake Rod as necessary. Refer to Section "ADJUSTMENTS - STEERING/BRAKES and TRACTION LEVERS/RODS".

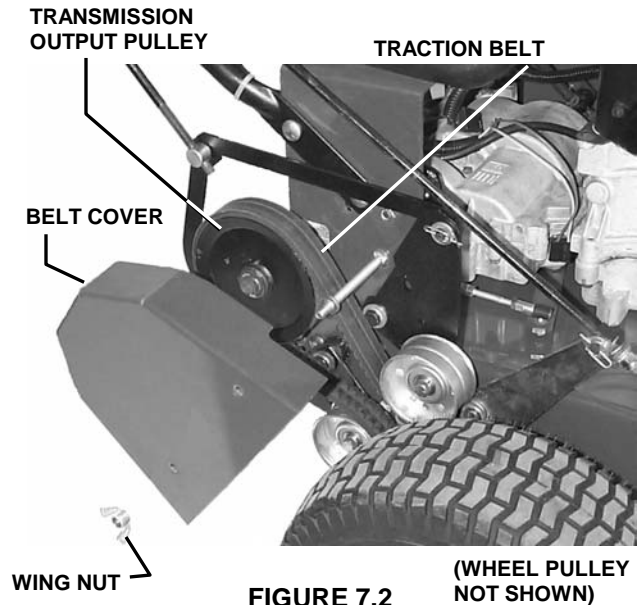

FIGURE 7.2

7.3 CUTTER DECK BELT REMOVAL & INSTALLATION

1. Remove mower deck belt cover.
 2. Remove idler spring and swing idler away from belt.
 3. Remove old belt from spindle pulleys and electric clutch pulley.
 4. Route new belt, part number 3-5710 for 36" Deck & 2-9261 for 48" Deck around spindle pulleys.
- NOTE:** 36" Deck Belt also connects to electric clutch.
5. Move idler to belt and re-attach tension spring. 48" Deck to electric clutch belt, use 2-9262.

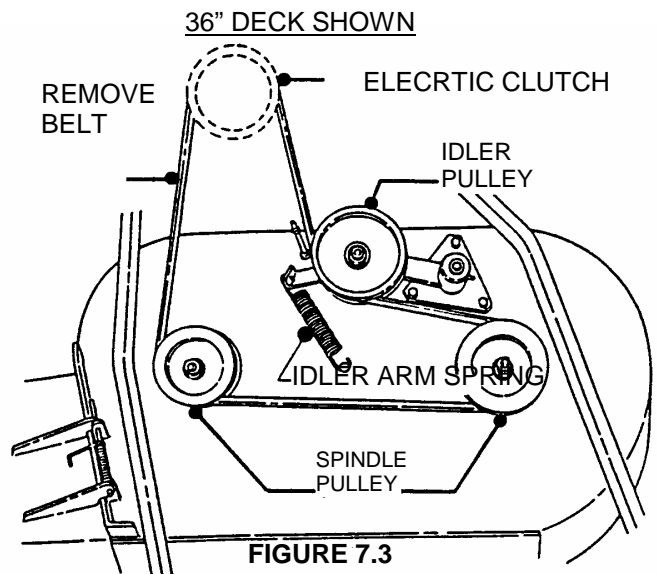

FIGURE 7.3

SECTION 7 - MOWER ATTACHMENT SERVICE

7.4 CUTTING BLADE SERVICE

Check blades after each use for signs of excessive wear and damage. See Figure 7.4 for blade wear limits.

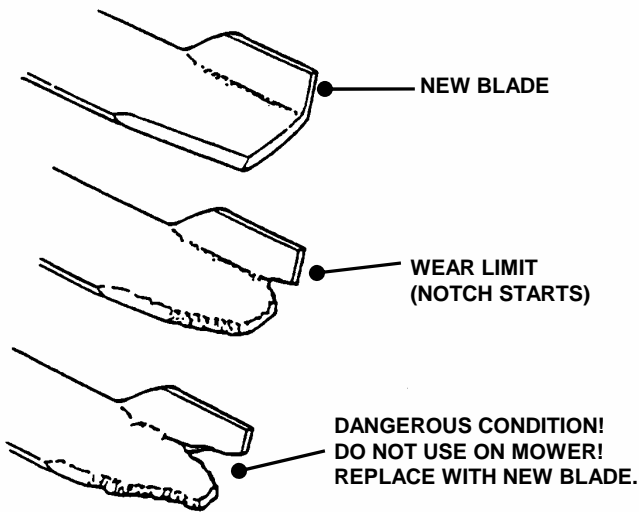

FIGURE 7.4

1. Use the following chart for ordering replacement Blades for the 36" & 48" Mowing Decks.

STANDARD REPLACEMENT BLADES

36" DECK	48" DECK
2-9246	2-9247

7.4.1. BLADE REMOVAL AND SHARPENING

1. Place the mower on a smooth level surface, turn engine **OFF**, remove key, disconnect Spark Plug Wire from Spark Plug and secure Wire away from Plug.
2. Remove blades.

IMPORTANT: Note the number of blade spacers that are under the Blade Mounting Nuts and on the Spindle side of the Blade.

3. Clean and inspect each Blade for excessive wear and damage. See Figure 7.4.
4. Refer to the STANDARD REPLACEMENT BLADE chart above for correct SNAPPER Replacement Blades.
5. Should Blades be in acceptable condition, sharpen at 22 to 28 degrees. DO NOT sharpen beyond original cutting edge. See Figure 7.5.
6. Balance each Blade after sharpening by grinding metal from the heavy end of the Blade.
7. Place the Blade mounting bolt through bevel washer and into Blade and place Blade Spacers over Bolt. Make certain each Blade is installed with the same amount of Spacers.

8.

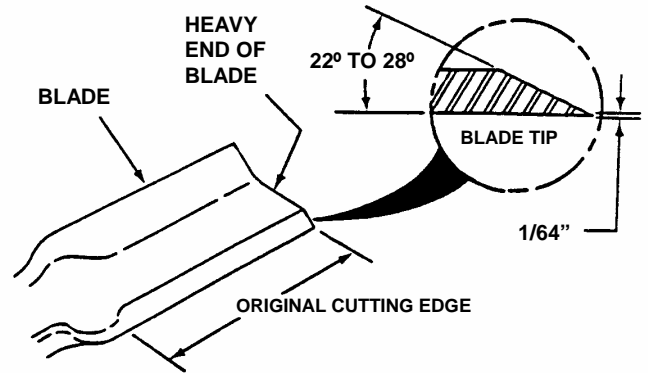
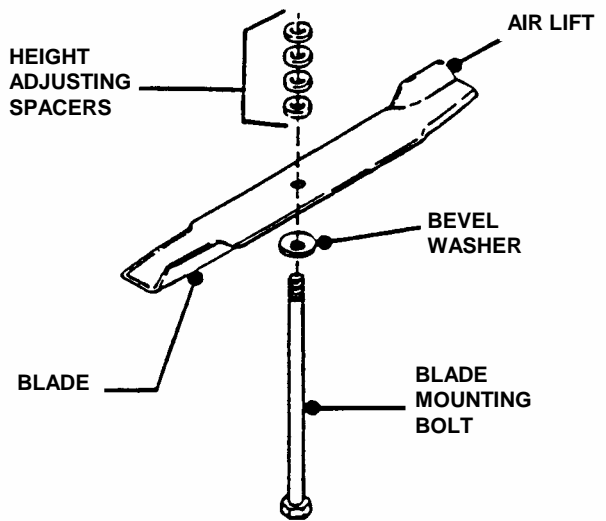

FIGURE 7.5

NOTE: When sharpening Blades, leave 1/64" untouched. Razor sharp Blades dull quicker and damage easier. Commercial balancers are available and should be used in accordance with the manufacturers instructions.

8. Install Blade Mounting Bolt with spacers and Blade into spindle.
9. Install an equal amount of Blade Spacers onto each blade mounting bolt.
10. Install the Blade Mounting Nut on each Blade Mounting Bolt. See Figure 7.6.
11. Torque each Blade Mounting Bolt and Nut to 60 to 75 ft. lbs. of torque.



TIGHTEN TO 60-75 FOOT POUNDS

FIGURE 7.6

SECTION 7 - MOWER ATTACHMENT SERVICE

7.5 MOWER SPINDLES (Field Serviceable Spindles) BEARING REPLACEMENT

In the event that a spindle bearing requires replacement, the SNAPPER Field Serviceable Spindles have been designed so that no special tools or presses are required.

1. Remove belt. Loosen blade nut and remove. Allow blade bolt, washer, blade and four spacers to drop down out of the spindle housing. See Figure 7.7.

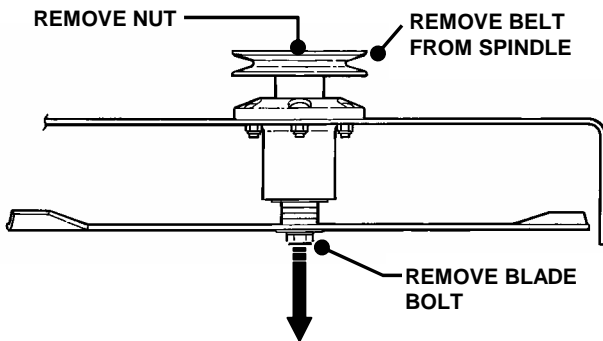

FIGURE 7.7

2. Remove spindle pulley from spindle shaft.
3. Locate circular retaining ring on spindle shaft at top bearing. Remove retaining ring. Allow spindle shaft to drop out of housing.
4. Top and bottom bearings are now removable. Pull out on inner race to slide bearing from housing. See Figure 7.8.

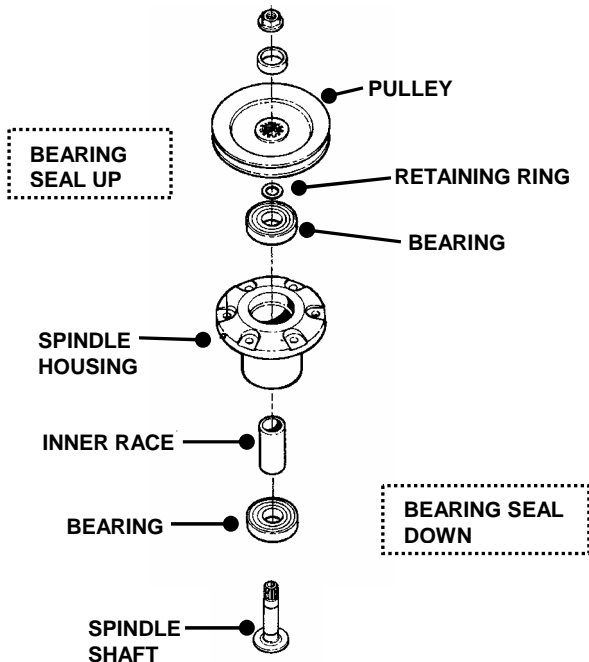

FIGURE 7.8

5. Thoroughly clean all parts removing all old contaminated grease.

6. Install new bottom bearing first.

NOTE: The bearing is sealed/shielded on one side only. The bottom bearing must be installed with the sealed/shielded side DOWN.

7. Insert spindle shaft up through the bottom bearing. Slide spacer down over spindle shaft.

8. Install new top bearing. Install the top bearing with the seal/shield UP.

9. Slide circular retaining ring down spindle shaft until it fully locks into groove on shaft.

10. Place spindle pulley and spacer on top of spindle shaft.

11. Reinstall blade bolt, washer, blade and four spacers.

12. Torque blade bolt and nut to 60 to 75 ft. lbs.

IMPORTANT: Spindle housing must be filled with grease before operating mower. Failure to fill housing will cause premature bearing failure.

13. Pump grease into spindle housing until grease purges from vent on housing.

14. After the first 5 hours of operation, grease spindle housing to insure it is full, then every 25 hours.

SECTION 8 - ELECTRICAL

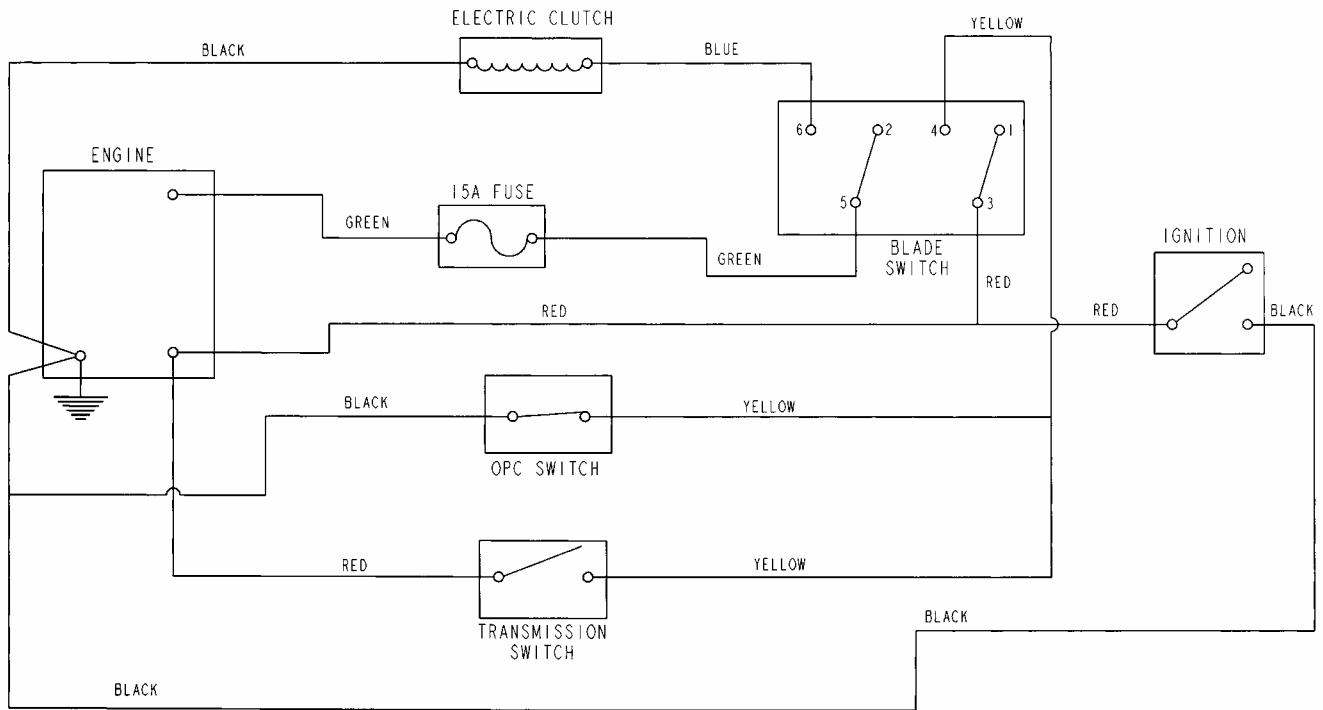

FIGURE 8.1

SNAPPER®

2 YEAR LIMITED WARRANTY

For two (2) years from purchase date for the original purchaser's use, **SNAPPER**, through any authorized **SNAPPER** dealer will replace, free of charge (except for taxes where applicable), any part or parts found upon examination by the factory at McDonough, Georgia, to be defective in material or workmanship or both.

SNAPPER FIELD SERVICEABLE SPINDLES and their components used on **SNAPPER PRO**® Mid Size walks and **SNAPPERZRIDER**® ride on commercial equipment have a three (3) year limited warranty against defects in material or workmanship or both.

All transportation costs incurred by the purchaser in submitting material to an authorized **SNAPPER** dealer for replacement under this warranty must be paid by the purchaser.

This warranty does not apply to engines and their components, and batteries, as these items are warranted separately. This warranty does not apply to parts that have been damaged by accident, alteration, abuse, improper lubrication, normal wear, or other cause beyond the control of **SNAPPER**. This warranty does not cover any machine or component that has been altered or modified, changing safety, performance, or durability.

Batteries have a one (1) year prorated warranty period with free replacement if required during the first ninety (90) days from the original purchase date. **SNAPPER** will not be responsible for any installation cost incurred. The battery warranty only covers original equipment batteries and does not cover damage to the battery or machine caused by neglect or abuse, destruction by fire, explosion, freezing, overcharging, improper maintenance, or use of improper electrolyte.

There is no other express warranty.

DISCLAIMER OF WARRANTY

Implied warranties, including those of merchantability and fitness for a particular purpose, are limited to two (2) years from purchase date for the original purchaser's use, and up to the extent permitted by law and all implied warranties are excluded. This is the exclusive remedy. Liabilities for consequential damages, under any and all warranties are excluded.

Some states do not allow limitations on how long an implied warranty lasts, or do not allow the exclusion or limitation of incidental or consequential damages, so the above limitation or exclusion may not apply to you.

This warranty gives you specific legal rights, and you may also have other rights which vary from state to state.

WARNING: THE USE OF REPLACEMENT PARTS OTHER THAN GENUINE SNAPPER PARTS MAY IMPAIR THE SAFETY OF SNAPPER PRODUCTS AND WILL VOID ANY LIABILITY AND WARRANTY BY SNAPPER ASSOCIATED WITH THE USE OF SUCH PARTS.

IMPORTANT: Please fill out the attached **SNAPPER** Product Registration Card immediately and mail to:
Snapper's Product Registration Center, P.O. Box 1379, McDonough, Georgia. 30253

PRIMARY MAINTENANCE

SNAPPER®

VS. DIRT!

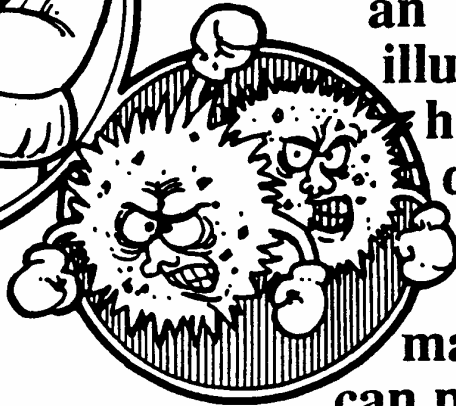
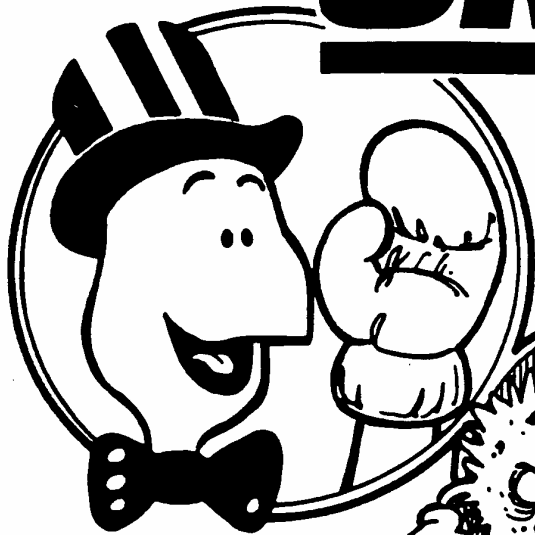

an illustration of how dirt can damage your engine & how reasonable maintenance can protect it!

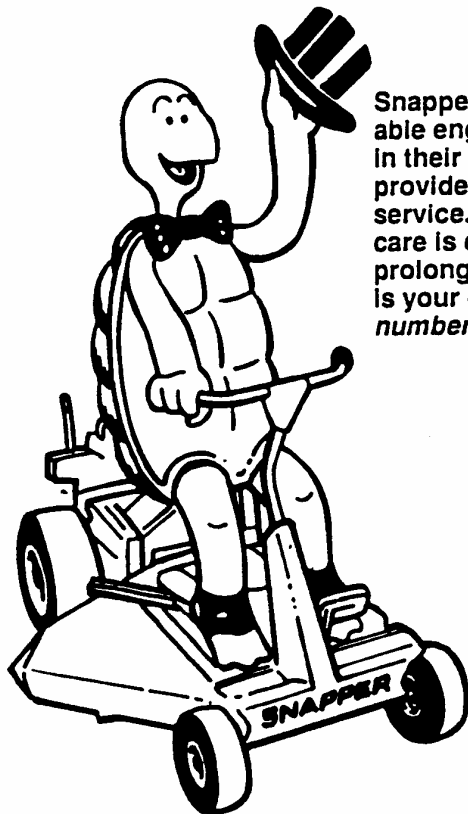

Snapper uses the best available engines and components in their products in order to provide long, satisfactory service. However, proper care is essential in prolonging engine life. Dirt is your engine's *enemy number 1!*

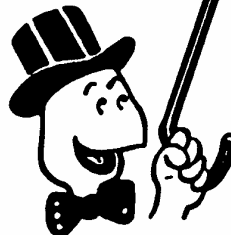
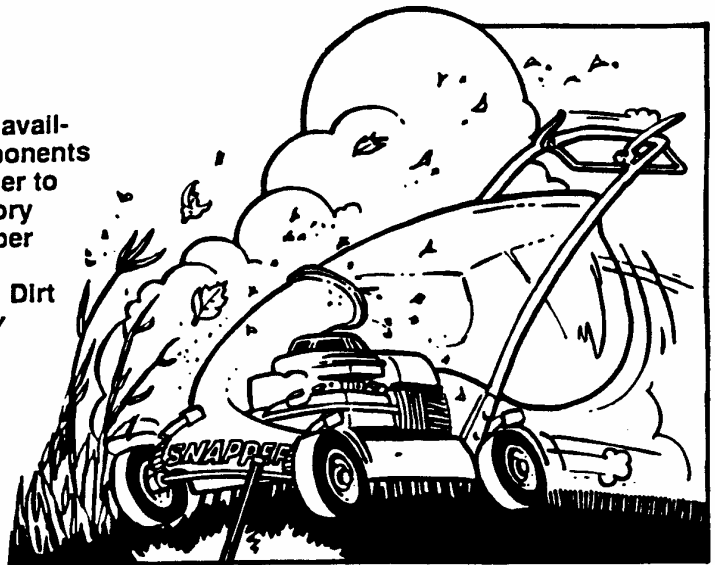

The engine on your Snapper product spends its entire life operating close to the ground at high speed creating a virtual storm of dust and dirt!

PRIMARY MAINTENANCE

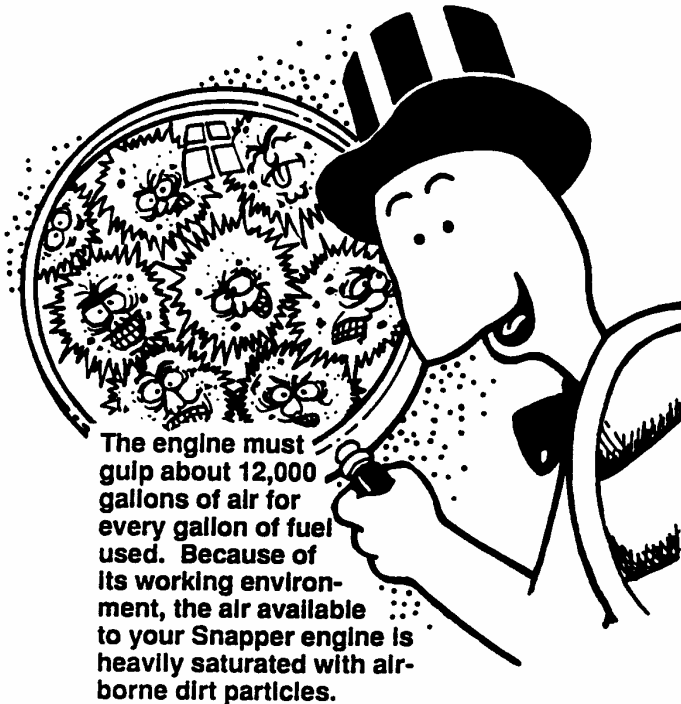

The engine must gulp about 12,000 gallons of air for every gallon of fuel used. Because of its working environment, the air available to your Snapper engine is heavily saturated with airborne dirt particles.

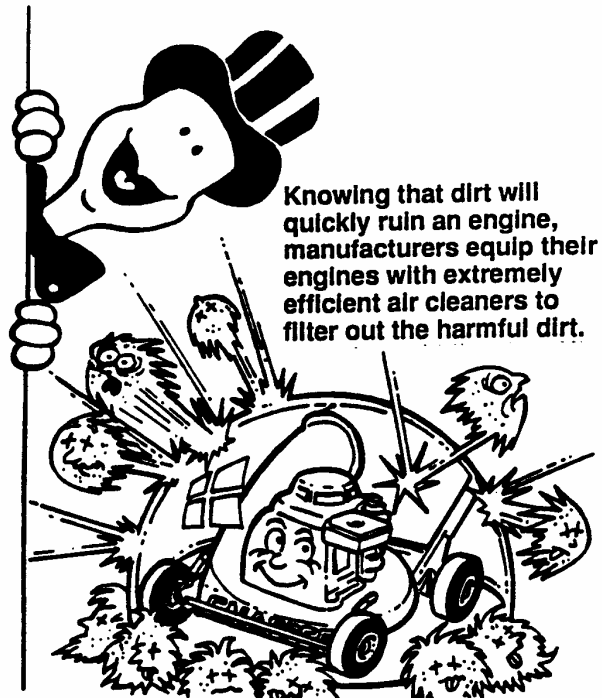

Knowing that dirt will quickly ruin an engine, manufacturers equip their engines with extremely efficient air cleaners to filter out the harmful dirt.

As the dirt particles are stopped, they build up and begin to clog the outside of the filter. This reduces the amount of air available to the engine and causes an over-rich fuel mixture which results in the following adverse effects:

An improperly serviced, dirt clogged air cleaner will:

1. Increase fuel consumption
2. cause power loss
3. result in hard starting
4. create smoke from unburned fuel
5. produce carbon build-up internally
6. foul spark plug electrodes
7. score cylinder walls
8. burn valves
9. wear out the engine prematurely
10. COST YOU MONEY!

Damage caused by a poorly serviced air cleaner is not covered under the engine warranties. So, save yourself unnecessary expenses and undue aggravation by keeping the air cleaner properly serviced at the intervals specified in the engine owner's manual.

It doesn't take long to service an air cleaner. Follow the specific instructions in the engine owner's manual for the type filter used. Prevent dirt from falling into the carburetor intake when servicing your air cleaner. Make sure components are installed in correct sequence after servicing to prevent unfiltered air from entering the engine. Some servicing hints on several common types are:

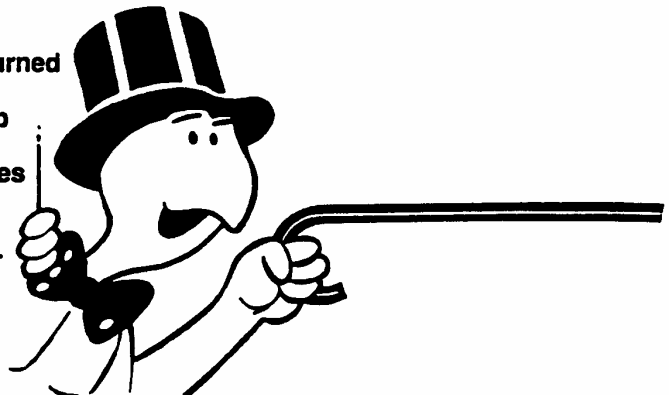
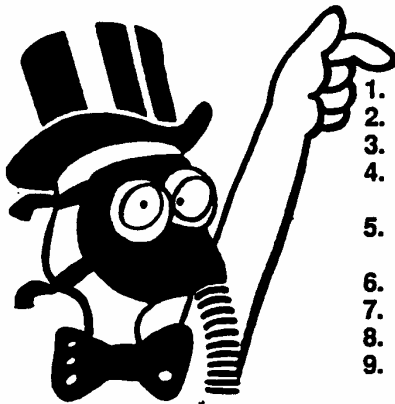

PRIMARY MAINTENANCE

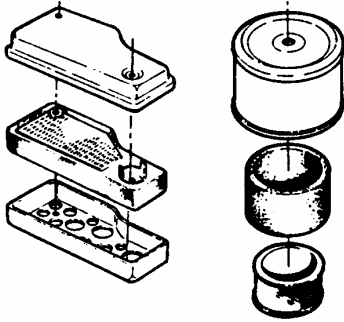

Generally, wash foam-type filters in a dishwashing detergent and water solution. Rinse and wring dry, then saturate with oil and squeeze out excess. *Failure to re-oil this type filter will ruin the engine.*

Clean paper elements by tapping lightly. Blowing with air will rupture paper elements.

Use a flashlight to detect clogged or torn paper elements - replace if damaged in any way.



Air is also needed to keep your engine cool. Dirt, dust & debris build up to restrict and clog cooling air intake screens and fins. Clean screens and fins at frequent intervals. The engine blower housing and shrouds should be removed at least once each season or more often under dry, dusty conditions for a thorough cleaning of fins.

Failure to keep external surfaces clean not only presents fire hazards, but causes overheating and resulting engine damages such as:

1. distorted valve guides
2. sticking valves
3. scuffed, scored cylinder walls
4. overspeeding
5. loss of power
6. complete failure of engine.

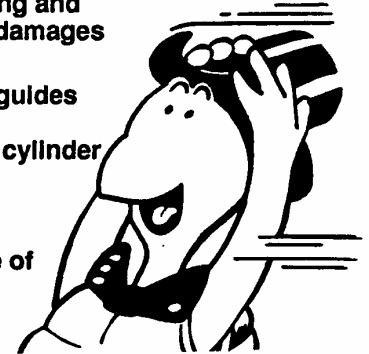

Dirt can also be introduced into an engine in dirty fuel from a contaminated container. Always use clean fresh fuel from a clean container to guard against dirt, sludge and water contamination.

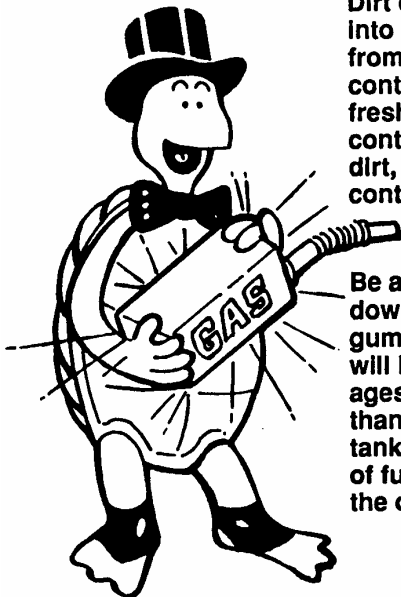

Be aware that fuel breaks down in storage and forms gummy compounds which will block carburetor passages. Never use fuel more than 3 months old. Drain tank then run the engine out of fuel before storing during the off-season.



An engine must also have proper lubrication. All engines use some oil. On 4-cycle engines, **CHECK OIL LEVEL BEFORE EACH START-UP.** Wipe area clean around the oil check plug or dipstick opening to keep dirt from falling into the engine when checking the oil. Always check with the machine on a level surface. On engines with dipstick, keep the level up to, but not over, the **FULL** mark. When adding oil, allow time for all of the oil to flow down the fill tube to prevent a false full reading when the level could actually be low and result in engine damage.

PRIMARY MAINTENANCE

On 4-cyle engines with an oil level plug, don't be fooled into thinking the engine has sufficient lubricating oil if you can see "some" oil in the opening - the level should always be brought up to the point of overflowing at the top of the fill hole.

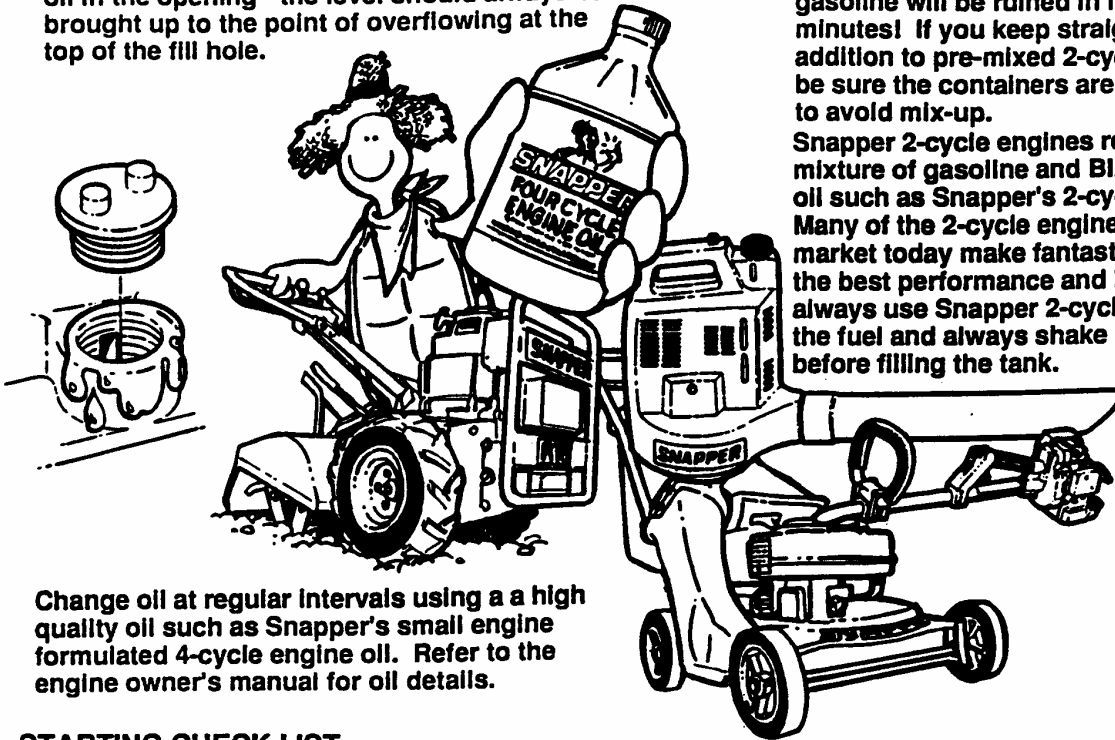

On 2-cycle engines, lubrication must be provided by an exact mixture of gasoline and 2-cycle air-cooled engine oil. A 2-cycle engine that is mistakenly run on straight gasoline will be ruined in less than 5 minutes! If you keep straight gasoline in addition to pre-mixed 2-cycle engine fuel, be sure the containers are clearly marked to avoid mix-up.

Snapper 2-cycle engines require a 32 to 1 mixture of gasoline and BIA certified TC-W oil such as Snapper's 2-cycle engine oil. Many of the 2-cycle engine oils on the market today make fantastic claims, but for the best performance and long engine life, always use Snapper 2-cycle oil. Pre-mix the fuel and always shake the container before filling the tank.

Change oil at regular intervals using a high quality oil such as Snapper's small engine formulated 4-cycle engine oil. Refer to the engine owner's manual for oil details.

STARTING CHECK LIST

- | | |
|------------------------------|--|
| 1. Engine Oil | <ul style="list-style-type: none"> • To full level (4-cycle) • Properly mixed with gas (2 cycle) |
| 2. Air Cleaner | <ul style="list-style-type: none"> • Clean and properly serviced • Full fresh clean gasoline |
| 3. Fuel Tank | <ul style="list-style-type: none"> • Fuel valve open • Cap vent open • Inline filter clean |
| 4. Choke | <ul style="list-style-type: none"> • Operating properly |
| 5. Primer (on some engines) | <ul style="list-style-type: none"> • Used properly |
| 6. Safety Interlock Switches | <ul style="list-style-type: none"> • In proper position • All wires properly connected |
| 7. Switch & Blade Control | <ul style="list-style-type: none"> • Switch On • Blade control properly positioned on walk mower |
| 8. Spark plug | <ul style="list-style-type: none"> • Wire connected • Good connection • Start position |
| 9. Throttle control | |
| 10. Blade | <ul style="list-style-type: none"> • Properly installed and torqued • Sharpened |
| 11. Muffler | <ul style="list-style-type: none"> • Good condition • Not clogged • Grass & leaves cleaned away |

Read and follow all safety instructions in safety booklets and manuals.

Keep in mind that dirt is your engine's *enemy #1* both internally and externally! Internally, dirt will quickly ruin an engine and externally it will cause overheating and resulting internal damages. Damage caused by improper lubrication, poor air cleaner service or overheating due to dirt cannot be covered under warranty.

It only takes a few moments to service the engine (and equipment) on a routine basis but the rewards will be a quick starting, responsive engine that will provide long satisfactory service with minimum maintenance cost. The prestart checklist in the next column and instructions in your Snapper Operator's Manual are designated to help you keep your Snapper in top operating condition with minimum effort!

Safety Instructions and Operator's Manual for

SNAPPER®

PRO GEAR EXPRESS

MID-SIZE

WALK BEHIND

MOWERS

SERIES 0

IMPORTANT

Snapper products are built using engines that meet or exceed all applicable emissions requirements on the date manufactured. The labels on those engines contain very important emissions information and critical safety warnings. Read, Understand, and Follow all warnings and instructions in this manual, the engine manual, and on the machine, engine and attachments. If you have any questions about your Snapper product, contact your local authorized Snapper dealer or contact Snapper Customer Service at Snapper, McDonough, GA. 30253. Phone: (1-800-935-2967).



WARNING

BATTERY POSTS, TERMINALS AND RELATED ACCESSORIES CONTAIN LEAD AND LEAD COMPOUNDS, CHEMICALS KNOWN TO THE STATE OF CALIFORNIA TO CAUSE CANCER AND BIRTH DEFECTS OR OTHER REPRODUCTIVE HARM. WASH HANDS AFTER HANDLING.



WARNING

ENGINE EXHAUST, SOME OF ITS CONSTITUENTS, AND CERTAIN VEHICLE COMPONENTS CONTAIN OR EMIT CHEMICALS KNOWN TO THE STATE OF CALIFORNIA TO CAUSE CANCER OR OTHER REPRODUCTIVE HARM.

SNAPPER® McDonough, GA., 30253 U.S.A.

COPYRIGHT © 2000
SNAPPER INC.
ALL RIGHTS RESERVED

MANUAL No. 7-3316 (I.R. 8/29/00)

Printed in U.S.A.