



Parts Manual



Prestige

4WD Series Garden Tractor & Mower Decks

27HP Product

Mfg. No.	Description
2690735	Prestige, 27HP Hydro 4WD w/PS RMO TRACTOR ONLY

Mower Decks

Mfg. No.	Description
1695424	44" Mower Deck
1695390	50" Mower Deck
1695266	54" Mower Deck

PRODUCT COMPONENTS	PAGES
Frame & Front Axle Group - 4WD	4
Steering Group - Power Steering	8
Engine & Electric Clutch Group - 23HP, 25HP & 27HP Kohler	10
Transmission Group	12
Controls Group	16
Cruise Control Group	18
Electrical Group	20
Hood, Grille & Dash Group	22
Seat & Seat Deck Group	24
Lift Group - Hydraulic Lift with Power Steering	26
Wheels & Tires Group	30
Decals Group	32
44" & 50" Mower Deck - Clutch & Support Group	34
44" Mower Deck - Electric Height Adjustment & Roller Bar Group	36
44" Mower Deck - Housing, Arbors & Blades Group	40
50" Mower Deck - Height Adjustment & Roller Group	44
50" Mower Deck - Housing, Arbors & Blades Group	48
54" Mower Deck - Clutch & Support Group	52
54" Mower Deck - Electric Height Adjustment & Roller Bar Group	54
54" Mower Deck - Housing & Arbor Group	58
Torque Specification Chart	Inside Back Cover

Frame & Front Axle Group - 4WD

987590

NOTE: Unless noted otherwise,
use the standard hardware torque
specification chart.

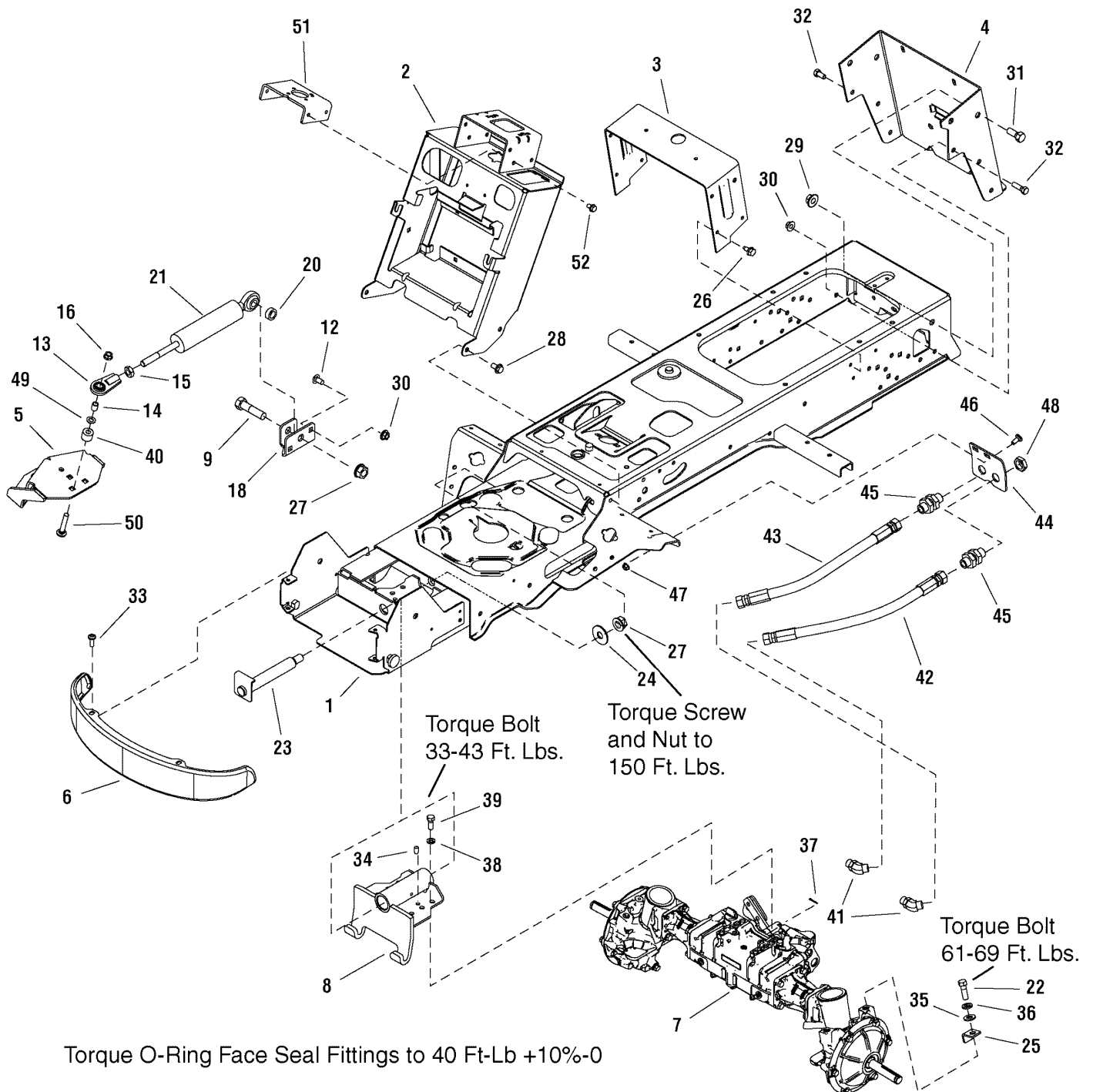

The above parts group applies to the following Mfg. Nos.:

2690735 - Prestige

Frame & Front Axle Group - 4WD

REF NO	PART NO.	QTY.	DESCRIPTION
1	1734731ASM	1	FRAME ASSEMBLY, Front & Rear 4WD
2	1733139ASM	1	TOWER & SUPPORT ASSEMBLY
3	1723528ASM	1	SUPPORT, Seat Deck
4	1722602ASM	1	BACKPLATE, Hitch
5	1733918ASM	1	BRACKET ASSEMBLY, Steering 4WD
6	1721805ASM	1	BUMPER, 4GA
7	1733480SM	1	AXLE ASSEMBLY, Front
8	1734241ASM	1	PIVOT ASSEMBLY, Axle w/Bushings
9	1960755SM	1	CAPSCREW, Hex Head, 5/8-11 x 2-1/2 G5
12	1931348SM	2	CARRIAGE BOLT, 3/9-16 x 3/4 G5
13	1702779SM	1	JOINT, Ball 1/2-20
14	1708236SM	1	SPACER
15	1919262SM	1	NUT, Hex Jam, 1/2-20
16	1930645SM	1	NUT, Hex Flange, 3/8-16 Two-Way Lock
18	1733166ASM	1	BRACKET, Cylinder Mounting
20	2172914SM	1	SPACER
21	1733759SM	1	CYLINDER, Hydraulic Steering
22	197487SM	3	CAPSCREW, Hex Head, M12-1-3/4 x 35
23	1733863SM	1	SHAFT & BRACKET ASSEMBLY, Axle Pivot
24	1960035SM	2	WASHER, 5/8
25	1734511ASM	1	STOP, "L" Steering
26	1664847SM	4	SCREW, Hex Washer Head Taptite, 5/16-18 x 3/4
27	2860646SM	2	NUT, Hex Flange 5/8-11 Two-Way Lock
28	1923683SM	4	SCREW, Hex Washer head, Taptite, 3/8-16 x 3/4
29	2860668SM	2	NUT, Hex Flange 1/2-13 Whiz Lock
30	1928352SM	4	NUT, Hex Flange 3/8-16 Whiz Lock
31	1923114SM	2	CAPSCREW, Hex Head 1/2-13 x 1 G5
32	1921210SM	2	CAPSCREW, Hex Head 3/8-16 x 1 G5
33	1960086SM	4	SCREW, Truss Head Torx Drive 5/16-18 x 7/8
34	1733581SM	2	PIN, Dowel
35	1960170SM	3	WASHER, 1/2
36	1916966SM	3	LOCKWASHER, Spring
37	1923360SM	1	PIN, Cotter
38	1960754SM	6	LOCKWASHER, Spring
39	1950036SM	6	CAPSCREW, Hex Head
40	1667812SM	1	SPACER, Powdered Metal
41	1733403SM	2	FITTING, Hose Elbow, 45 Degrees, 13/16-16 x 3/4-16
42	1733400SM	1	HOSE ASSEMBLY, Hydraulic
43	1733891SM	1	HOSE ASSEMBLY, Hydraulic
44	1733501ASM	1	BRACKET, Hose Mounting 10GA
45	1733402SM	2	FITTING, Bulkhead Union 13/16-16
46	1931333SM	2	CARRIAGE BOLT, 5/16-18 x 3/4 G5
47	1960636SM	2	NUT, Hex KEPS, 5/16-18
48	1733947SM	2	NUT, Jam 13/16-16
49	1960103SM	1	WASHER, 3/8

Footnotes

The above parts group applies to the following Mfg. Nos.:

2690735 - Prestige

Frame & Front Axle Group - 4WD

987590

NOTE: Unless noted otherwise,
use the standard hardware torque
specification chart.

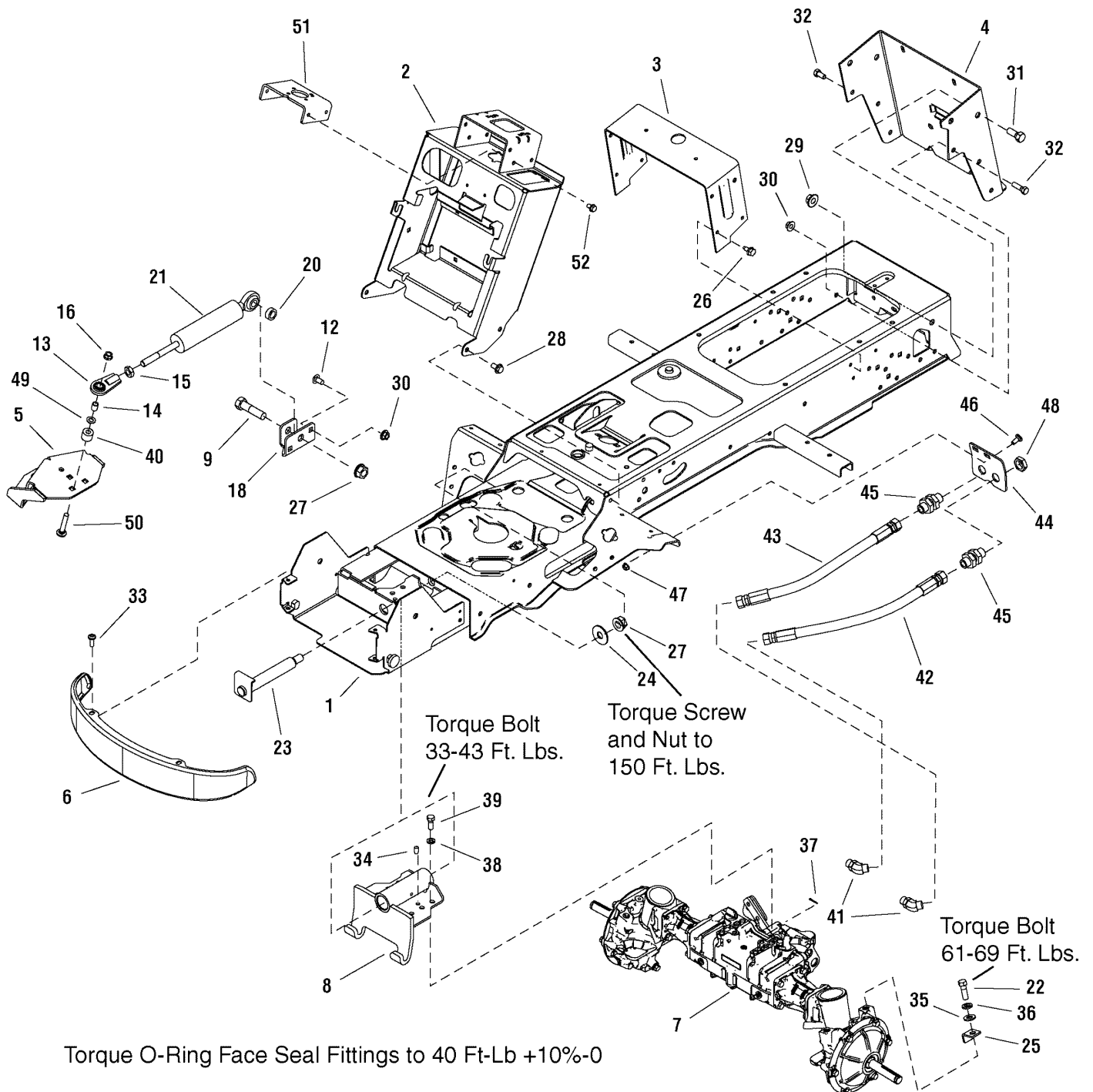

The above parts group applies to the following Mfg. Nos.:

2690735 - Prestige

Frame & Front Axle Group - 4WD

REF NO	PART NO.	QTY.	DESCRIPTION
51	1733044ASM	1	SUPPORT, Steering Unit 7GA
52	1924856SM	4	SCREW, Hex Washer Head Taptite 5/16-18 x 1/2

Footnotes

The above parts group applies to the following Mfg. Nos.:

2690735 - Prestige

Steering Group - Power Steering

987424

NOTE: Unless noted otherwise,
use the standard hardware torque
specification chart.

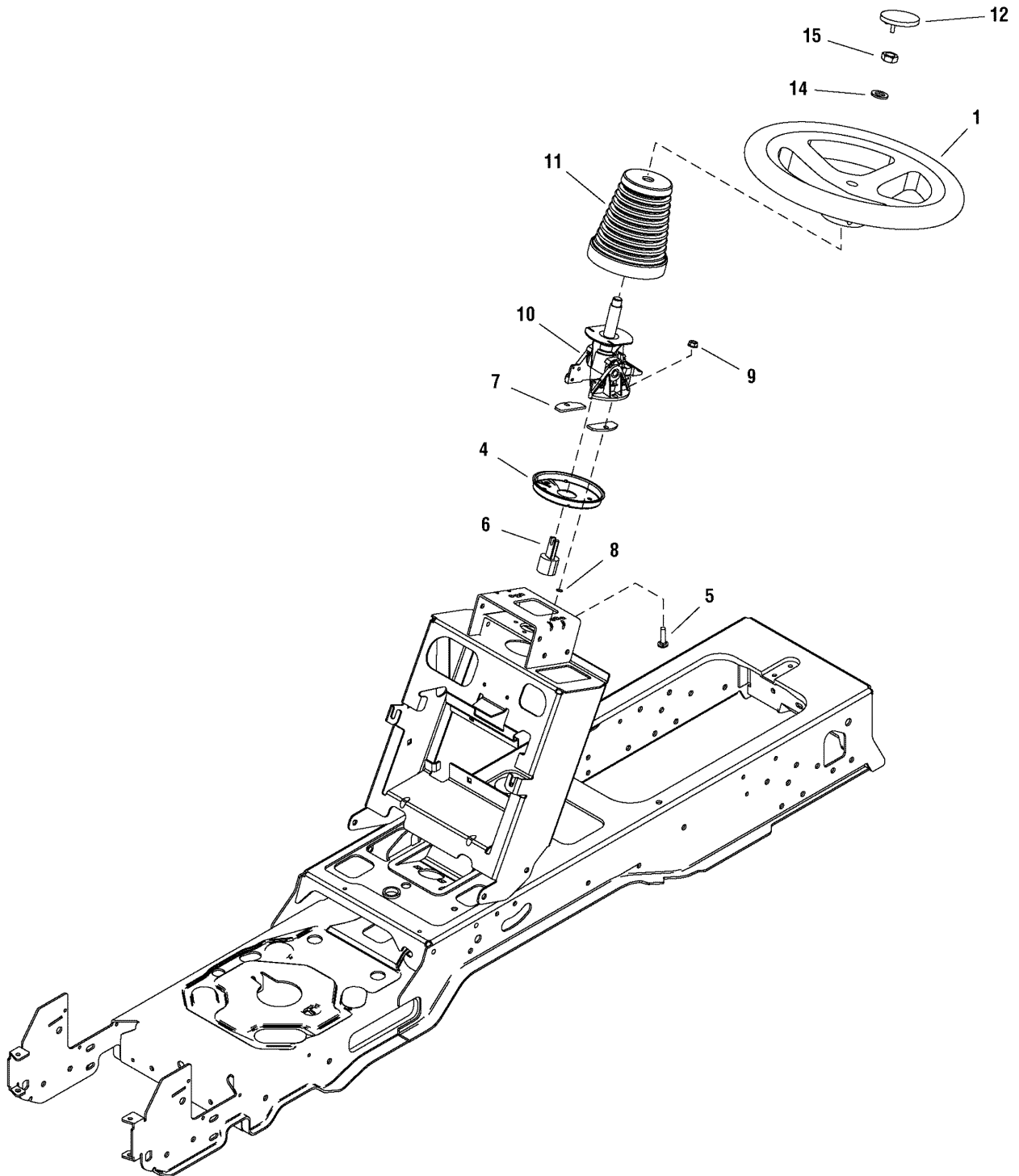

The above parts group applies to the following Mfg. Nos.:

2690735 - Prestige

Steering Group - Power Steering

REF NO	PART NO.	QTY.	DESCRIPTION
1	1733363SM	1	STEERING WHEEL
4	1724685ASM	1	PLATE, Steering Mounting
5	1960655SM	2	CARRIAGE BOLT, 5/16-18 x 1-1/4 G5
6	1725294SM	1	ADAPTER, Tilt
7	1723898SM	2	SPACER
8	1933988SM	2	NUT, Push Pal
9	1960636SM	2	NUT, Hex Keps 5/16-18
10	1733790SM	1	STEERING UNIT, Tilt
11	1686970SM	1	BELLOWS, Tilt Steering Unit w/Slot
12	1725024SM	1	CAP, Steering Wheel
13	1716518SM	2	DECAL, Power Steering (Not Shown)
14	1924366SM	1	WASHER, 5/8
15	1960576SM	1	NUT, Hex Lock ESNA Light 5/8-18

Footnotes

The above parts group applies to the following Mfg. Nos.:

2690735 - Prestige

Engine & Electric Clutch Group - 23HP, 25HP & 27HP Kohler

985906

NOTE: Unless noted otherwise, use the standard hardware torque specification chart.

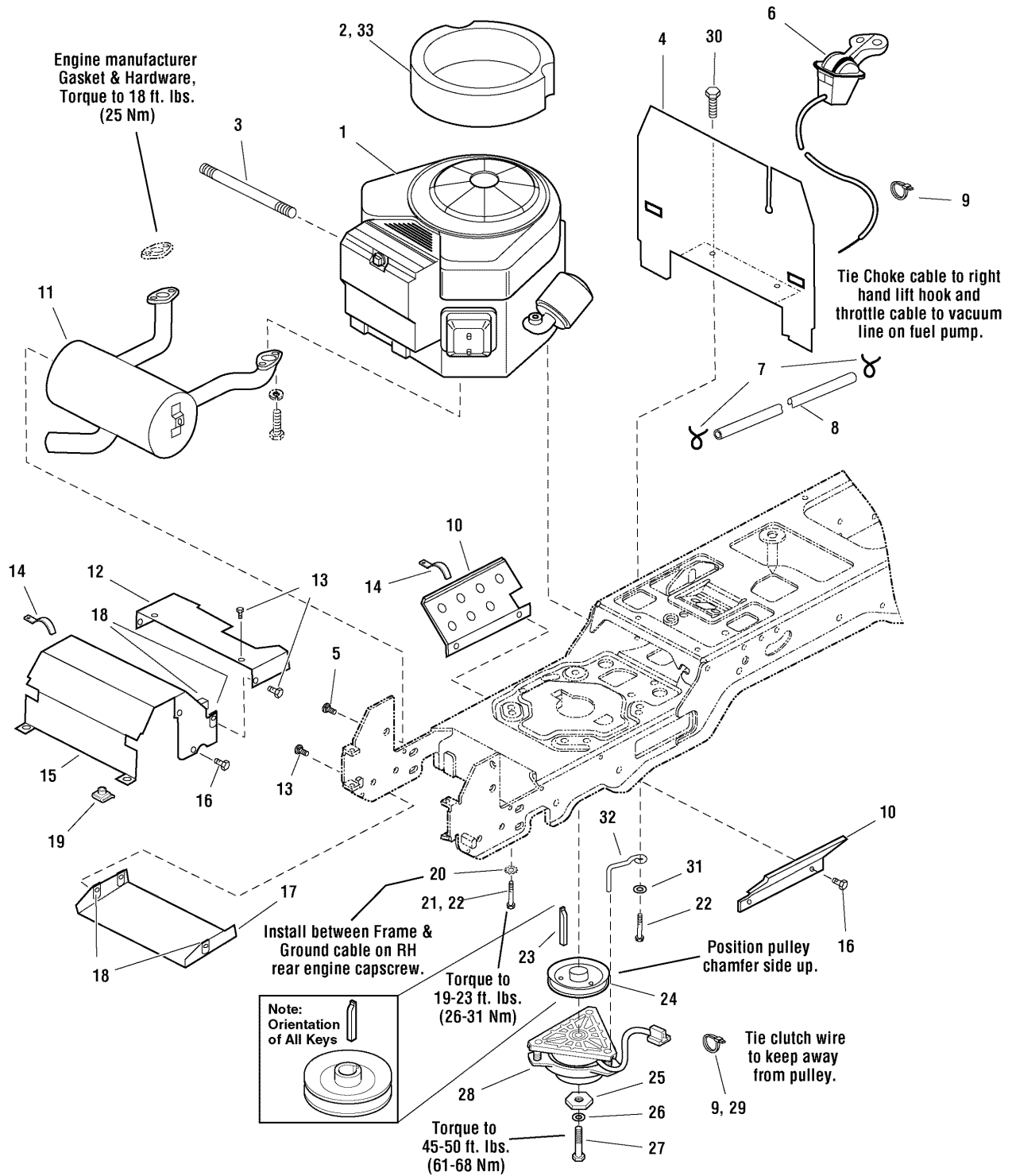

The above parts group applies to the following Mfg. Nos.:

2690735 - Prestige

Engine & Electric Clutch Group - 23HP, 25HP & 27HP Kohler

REF NO	PART NO.	QTY.	DESCRIPTION
1	*	1	ENGINE, 23HP Kohler Command - Model CV23S Spec PS-75553
1	*	1	ENGINE, 25HP Kohler Courage Twin - Model SV730S Spec PS-SV730-0020
1	*	1	ENGINE, 25HP Kohler Command Twin - Model CV730S
1	*	1	ENGINE, 27HP Kohler Command Twin - Model CV740S Spec PS-CV740-0040
2	1719847SM	1	SEAL, Foam (Only used on 23HP Models)
3	1723165SM	1	HOSE, Oil Drain
4	1722388ASM	1	BULKHEAD
5	1924856SM	2	SCREW, Hex Washer Head Taptite 5/16-18 x 1/2
6	1727223SM	1	CONTROL, Throttle Double 39.0 LG w/Knobs (Used on all models except 25HP Kohler Courage)
6	1727375SM	1	THROTTLE, Control Double 51.0 LG w/Knobs (Only used on 25HP Kohler Courage)
7	2860112SM	1	CLAMP, Hose
8	1718678SM	1	HOSE, Fuel
9	1701011SM	3	TIE, Self Locking
10	1722392ASM	2	SHIELD, Side
11	1721705SM	1	MUFFLER, Kohler Twin
12	1722390ASM	1	DUCT, Muffler (Used on all models except 25HP Kohler Courage)
12	1733884ASM	1	DUCT, Muffler (Only used on 25HP Kohler Courage)
13	1960295SM	4	SCREW, Hex Whiz Lock Flange 1/4-20 x 5/8
14	2834683SM	2	CLIP, Speed Wire
15	1722389ASM	1	DUCT, Muffler Top
16	1929000SM	8	SCREW, Hex Washer Head Taptite 1/4-20 x 3/8
17	1722414ASM	1	SHIELD, Muffler
18	1960368SM	4/8	NUT, Speed 1/4-20 Lug Type
19	1935255SM	2	NUT, Speed 5/16-18 Lug Type
20	2820427SM	1	LOCKWASHER, External Tooth 3/8
21	2827187SM	3/4	SCREW, Hex Washer Head Taptite 3/8-16 x 1 (Used only on 25HP Courage & 27HP Command)
22	2830598SM	1/4	SCREW, Hex Washer Head Taptite 3/8-16 x 1-1/2 (Used on all models except 27HP)
23	1720463SM	1	KEY, Hi-Pro
24	1722288SM	1	PULLEY & HUB ASMY
25	1708264SM	1	WASHER, Hex
26	1918199SM	1	LOCKWASHER, Spring
27	1960649SM	1	CAPSCREW, Hex Head 7/16-20 x 3-1/2 G5
28	1686883SM	1	CLUTCH, Electric
29	2832747SM	1	TIE, Self Locking (Used only on 23HP models)
30	1925003SM	2	SCREW, Hex Washer Head Taptite 1/4-20 x 1/2
31	1924940SM	1	WASHER, 3/8 (Used on all models except 23HP)
32	1732026SM	1	RETAINER, Clutch (Used on all models except 23HP)
33	1731971SM	1	EDGING, Rubber (Used on all models except 23HP)

Footnotes

Note * See your local Kohler distributor for parts and service.

The above parts group applies to the following Mfg. Nos.:

2690735 - Prestige

Transmission Group

987547

NOTE: Unless noted otherwise,
use the standard hardware torque
specification chart.

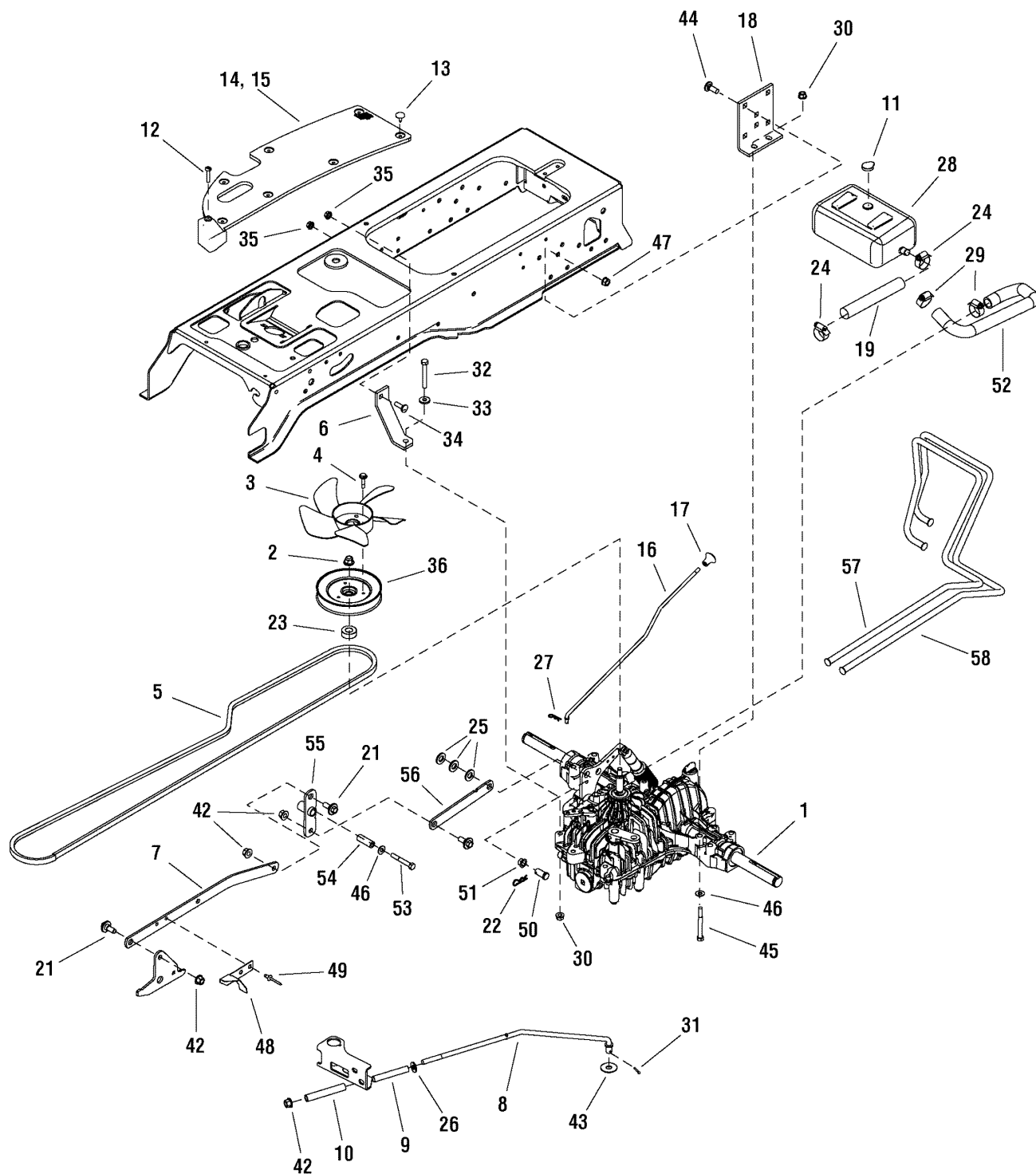

The above parts group applies to the following Mfg. Nos.:
2690735 - Prestige

Transmission Group

REF NO	PART NO.	QTY.	DESCRIPTION
1	1733478SM	1	TRANSMISSION ASSEMBLY, K664
2	1722194SM	1	PULLEY & HUB ASSEMBLY
3	1719233SM	1	FAN
4	1933958SM	3	SCREW, Hex Washer Head, Taptite, 1/4-20 x 1-1/4
5	1721392SM	1	BELT, 94.05
6	1721593ASM	1	STRAP, 4-1/4 Long
7	1733318ASM	1	ARM, Control 7GA
8	1721424SM	1	ROD, 17-27/64 Long
9	1722684SM	1	SPRING, Compression
10	1729277SM	1	SPRING, Compression
11	1722711SM	1	CAP, Expansion
12	1960676SM	2	SCREW, Pan Head Torx, 1/4-20 x 1-1/4 Taptite
13	1704351SM	15	FASTENER, Panel
14	1722174SM	1	PAD, Footrest L.H.
15	1722173SM	1	PAD, Footrest R.H.
16	1721622SM	1	ROD, Free Wheel
17	1723126SM	1	KNOB, Interior Thread
18	1721728ASM	2	SUPPORT, Transmission
19	1733531SM	1	HOSE, Hydraulic
21	1732129SM	3	BOLT, Shoulder, 3/8-16
22	1960074SM	1	CLIP, Hair Pin
23	1734337SM	1	SPACER
24	2860266SM	1	CLAMP, Hose Worm
25	1960027SM	3	WASHER, 1/2
26	1924940SM	1	WASHER, 3/8
27	1722460SM	1	PIN, Quick
28	1732989SM	1	TANK, Oil Natural
29	1723214SM	2	CLAMP, Hose Worm
30	1960686SM	6	NUT, Hex Flange 5/16-18 ESNA
31	1918447SM	1	COTTER PIN
32	1921719SM	1	CAPSCREW, Hex Head 5/16-18 x 2-1/2 G5
33	1960141SM	1	WASHER, 5/16
34	1931335SM	1	CARRIAGE BOLT, 5/16-18 x 1 G5
35	1960636SM	2	NUT, Hex KEPS 5/16-18
36	1719968SM	1	NUT, Hex Flange
42	1960687SM	4	NUT, Hex Flange 3/8-16 ESNA
43	1918267SM	1	WASHER, 7/16
44	1931350SM	6	CARRIAGE BOLT, 3/8-16 x 1 G5
45	1960590SM	4	CAPSCREW, Hex Head 5/16-18 x 3 G5
46	1919326SM	3	WASHER, 5/16
47	1960637SM	6	NUT, Hex Keps 3/8-16
48	1727215ASM	1	ACTUATOR, Switch
49	1960241SM	2	POP RIVET
50	1724107SM	1	PIN, Clevis
51	1722648SM	1	BEARING

Footnotes

The above parts group applies to the following Mfg. Nos.:

2690735 - Prestige

Transmission Group

987547

NOTE: Unless noted otherwise,
use the standard hardware torque
specification chart.

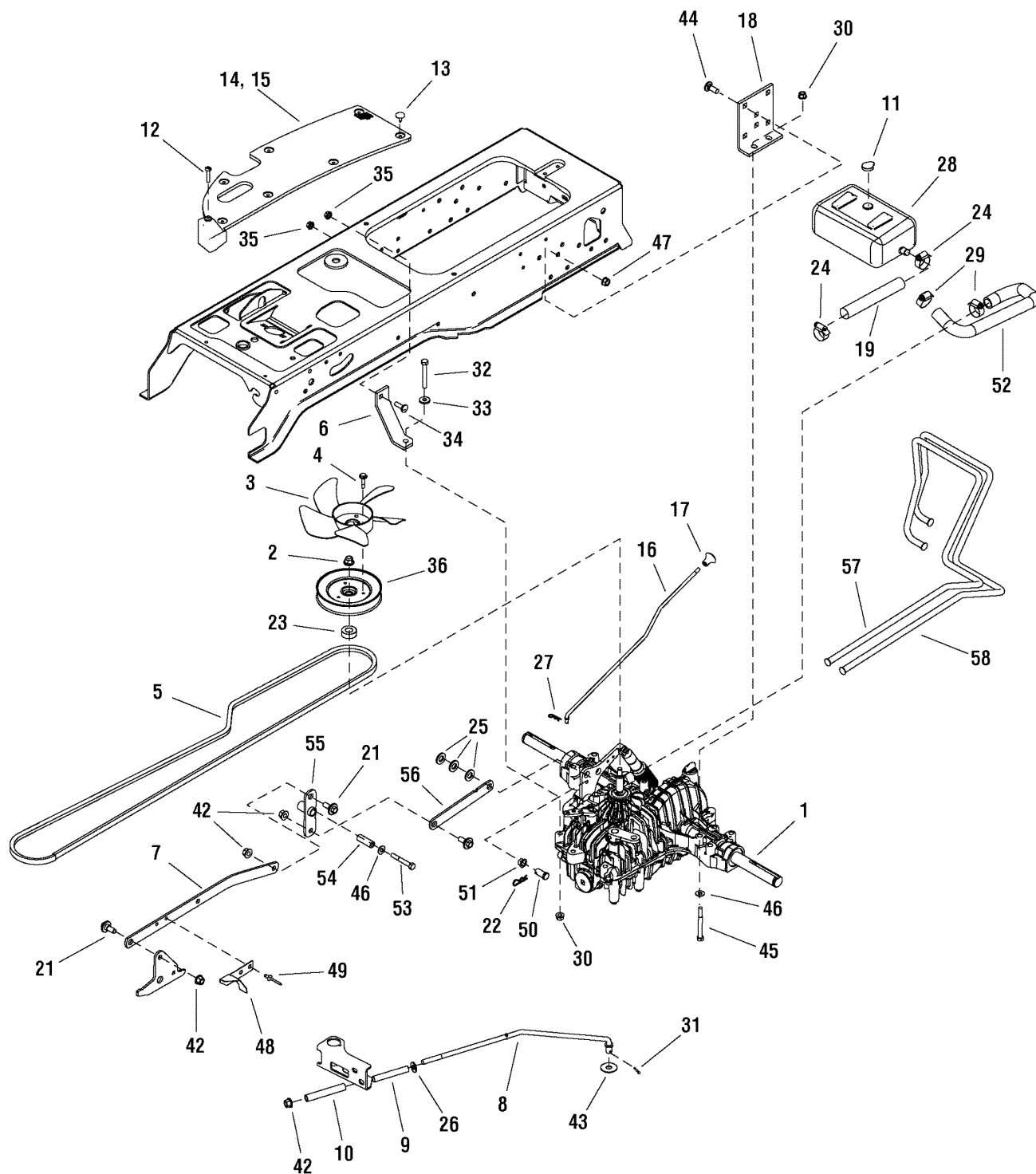

The above parts group applies to the following Mfg. Nos.:
2690735 - Prestige

Transmission Group

REF NO	PART NO.	QTY.	DESCRIPTION
53	1921160SM	1	CAPSCREW, Hex Head, 5/16-18 x 2-1/4 G5
54	1713588SM	1	SPACER
55	1733320ASM	1	PIVOT ASSEMBLY, Control
56	1733525ASM	1	ARM, Control
57	1733483SM	1	TUBE, Hydraulic 4WD
58	1733484SM	1	TUBE, Hydraulic Rear

Footnotes

The above parts group applies to the following Mfg. Nos.:

2690735 - Prestige

Controls Group

986599

NOTE: Unless noted otherwise,
use the standard hardware torque
specification chart.

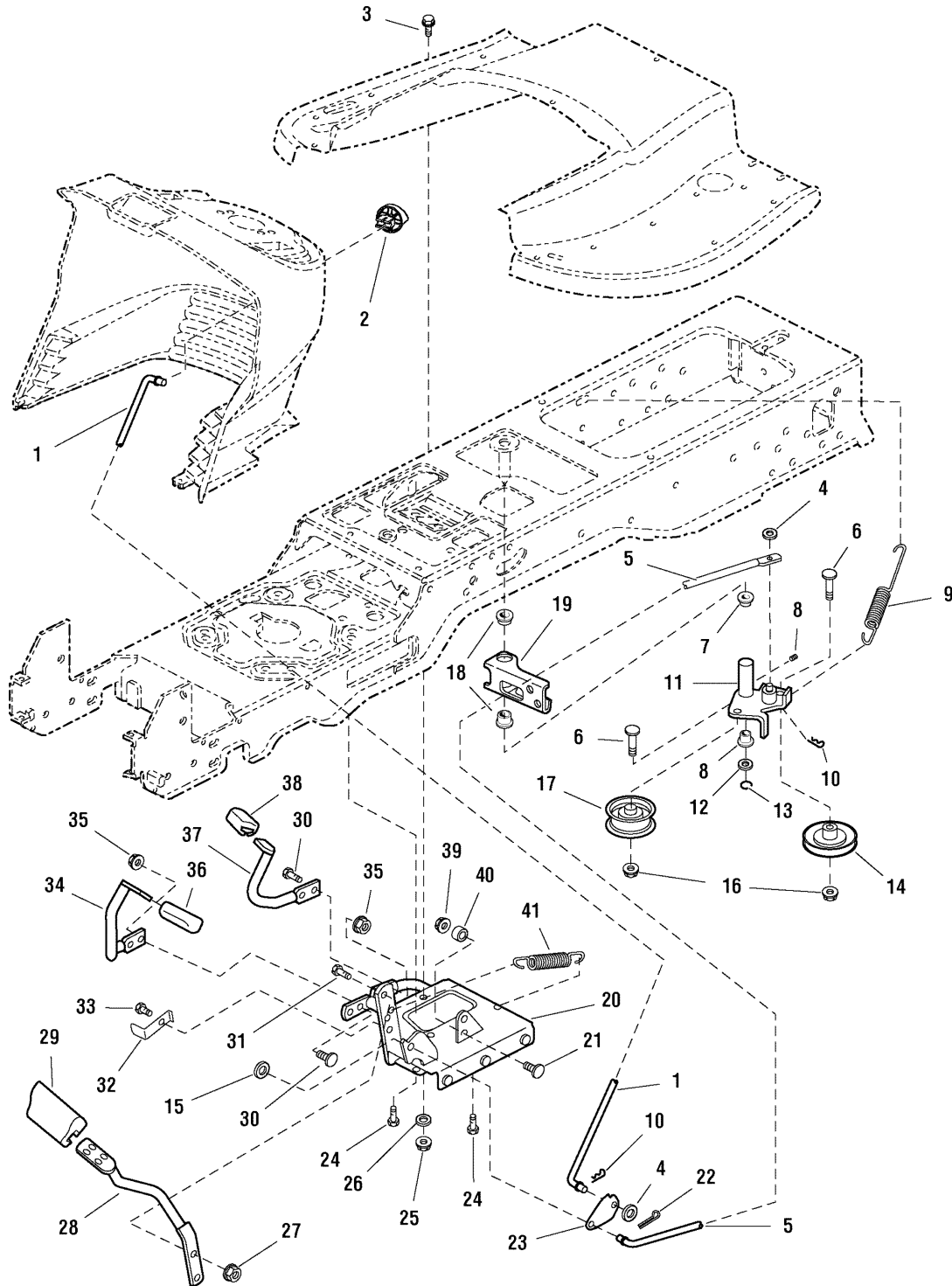

The above parts group applies to the following Mfg. Nos.:
2690735 - Prestige

Controls Group

REF NO	PART NO.	QTY.	DESCRIPTION
1	1721353SM	1	ROD, Brake Lock
2	1721891SM	1	KNOB, Push On, Red Plastic "P"
3	1930591SM	1	CAPSCREW, Hex Flange Whiz Lock, 5/16-18 x 3/4
4	1919326SM	2	WASHER, 5/16, Black
5	1721476SM	1	ROD, Brake
6	1931353SM	2	CARRIAGE BOLT, 3/8-16 x 1 3/4
7	1663114SM	2	BUSHING, 5/8 x 3/4 x 3/4, Nylon
8	2821133SM	1	FITTING, Lube, 1/4
9	1725250SM	1	SPRING, Extension
10	1722460SM	3	PIN, Quick
11	1724917SM	1	ARM & HUB ASSEMBLY, Idler
12	1960020SM	1	WASHER, 5/8
13	1704420SM	1	RING, Clipping Extension
14	1721134SM	1	PULLEY, w/Bearing
15	1924940SM	1	WASHER, 3/8
16	1960687SM	2	NUT, Hex Flange ESNA, 3/8-16
17	1721133SM	1	PULLEY, Idler
18	1723237SM	2	BUSHING, 1 x 1-1/8 x 5/8, Nylon
19	1722513SM	1	ARM, Brake
20	1726763SM	1	PEDAL ASSEMBLY, Foot
21	1931320SM	1	CARRIAGE BOLT, 1/4-20 x 1-1/4
22	1918447SM	1	PIN, Cotter, Black
23	1721354ASM	1	LATCH, Brake
24	1664847SM	3	CAPSCREW, Hex Washer Head Taptite, 5/16-18 x 3/4
25	1919438SM	1	NUT, Hex Lock ESNA Light, 5/16-18
26	1919381SM	1	WASHER, 5/16, Black
27	1927557SM	2	NUT, Hex Flange Whiz Lock Large, 5/16-18
28	1722535ASM	1	PEDAL, Brake
29	1721577SM	1	PAD, Brake Pedal
30	1931334SM	4	CARRIAGE BOLT, 5/16-18 x 7/8
31	1921333SM	2	CAPSCREW, 5/16-18 x 1
32	1722083ASM	1	ACTUATOR, Switch 2.53" Long
33	1923683SM	1	CAPSCREW, Hex Washer Head Taptite, 3/8-16 x 3/4
34	1722070ASM	1	PEDAL, Forward
35	1960636SM	4	NUT, Hex KEPS, 5/16-18
36	1721675SM	1	PAD, Foot Pedal Forward
37	1722071ASM	1	PEDAL, Reverse
38	1721674SM	1	PAD, Foot Pedal Reverse
39	1920397SM	1	NUT, Hex Lock ESNA Light, 1/4-20
40	1686612SM	1	CAM, Roller
41	1721995SM	1	SPRING, Extension

Footnotes

The above parts group applies to the following Mfg. Nos.:

2690735 - Prestige

Cruise Control Group

985883

NOTE: Unless noted otherwise, use the standard hardware torque specification chart.

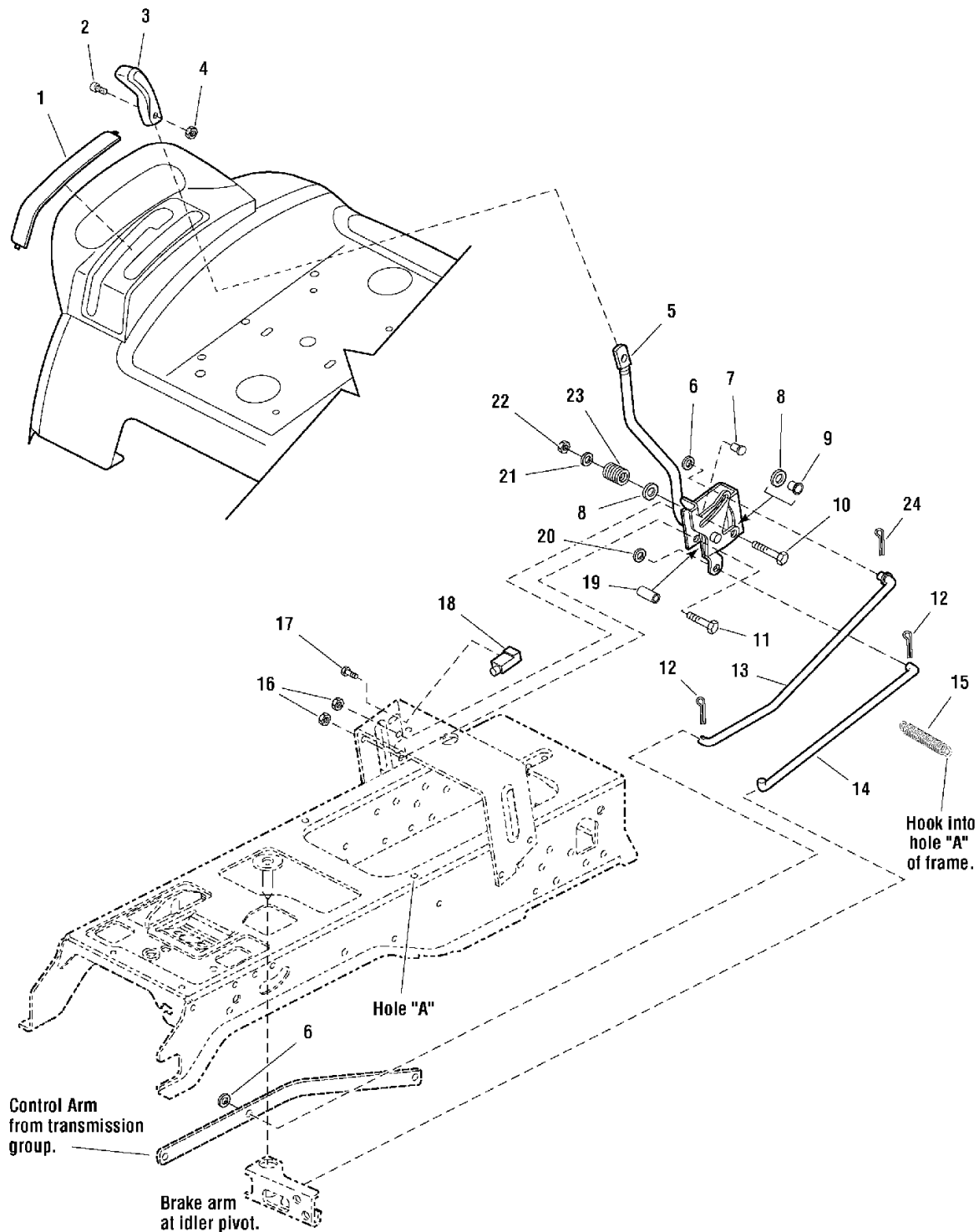

The above parts group applies to the following Mfg. Nos.:

2690735 - Prestige

Cruise Control Group

REF NO	PART NO.	QTY.	DESCRIPTION
1	1722314SM	1	COVER, w/Cruise Icon
2	1960666SM	1	SCREW, Torque Head Plus Socket Head, 1/4-20 x 7/8
3	1722303SM	1	KNOB, Cruise
4	1920397SM	1	NUT, Hex Lock ESNA Light, 1/4-20
5	1722003SM	1	LEVER & BRACKET ASSEMBLY, Cruise
6	1960103SM	2	WASHER, 3/8, Black
7	1931333SM	1	CARRIAGE BOLT, 5/16-18 x 3/4
8	1924361SM	2	WASHER, 1/2
9	1709043SM	1	SPACER, w/Flange, 11/32 x 15/32 x 3/4
10	1931342SM	1	CARRIAGE BOLT, 5/16-18 x 2-3/4
11	1960273SM	1	CARRIAGE BOLT, 5/16-18 x 2-1/4
12	1722460SM	2	PIN, Quick
13	1722117SM	1	ROD, Cruise
14	1733719SM	1	ROD, Return
15	2159106SM	1	SPRING, Cruise Return to Frame
16	1960636SM	2	NUT, Hex KEPS, 5/16-18
17	1960001SM	2	CAPSCREW, Hex Washer Head Plastite, 10-14 x 5/8
18	1717050SM	1	SWITCH, Push, Neutral Start, Gray
19	1722080SM	1	SPACER, 11/32 x 5/8 x 1-13/32
20	1919326SM	1	WASHER, 5/16, Black
21	1919381SM	1	WASHER, 5/16, Black
22	1919438SM	1	NUT, Hex Lock ESNA Light, 5/16-18
23	1677746SM	1	SPRING, Compression
24	1918447SM	1	PIN, Cotter

Footnotes

The above parts group applies to the following Mfg. Nos.:

2690735 - Prestige

Electrical Group

986606

NOTE: Unless noted otherwise, use the standard hardware torque specification chart.

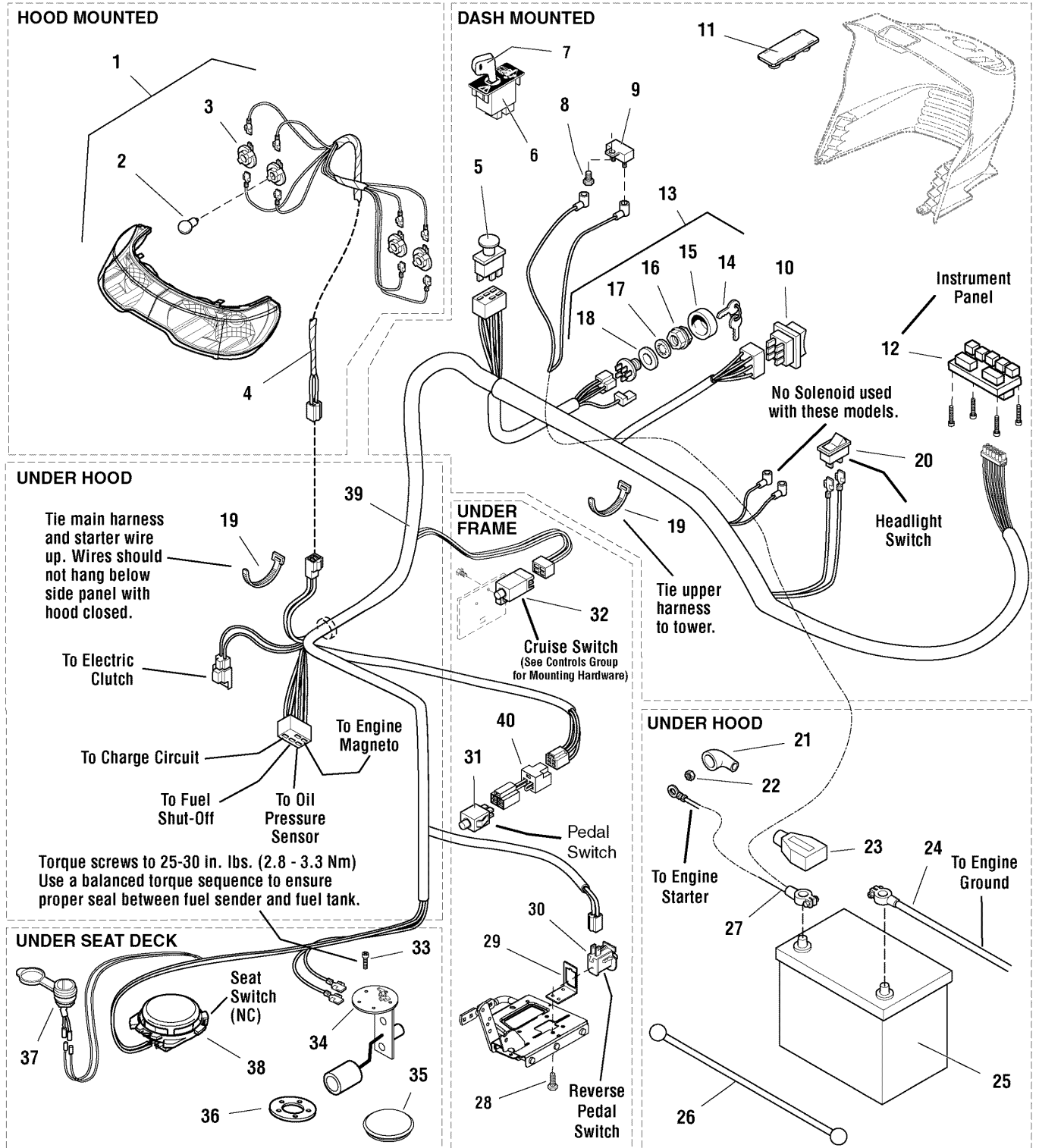

The above parts group applies to the following Mfg. Nos.:

2690735 - Prestige

Electrical Group

REF NO	PART NO.	QTY.	DESCRIPTION
1	1721810SM	1	HEADLIGHT ASSEMBLY, 4 Bulb (Includes Ref. Nos. 2 & 3)
2	1677371SM	4	BULB, Headlight, 12.8V
3	1723451SM	4	SOCKET ASSEMBLY, Headlight, Sealed
4	1722669SM	1	HARNESS, Headlight
5	1722887SM	1	SWITCH, PTO Push
6	1726556SM	1	SWITCH, Reverse Mow Option Module w/Key
7	1726557SM	1	KEY, No Mow Module
8	1925003SM	2	SCREW, Hex Washer Head Taptite 1/4-20 x 1/2
9	1665238SM	1	BREAKER, Circuit
10	1716329SM	1	SWITCH, Electric Lift Rocky (Used only on Electric HOC Models)
11	1722611SM	1	PLUG, Hole
12	1725074SM	1	PANEL, Instrument w/Fuel Gage
13	1686734SM	1	SWITCH ASSEMBLY, Ignition
14	1717163SM	1	KEY, Ignition
15	1717550SM	1	COVER, Switch
16	1717549SM	1	NUT, Hex Flange 5/8-32 Ignition Switch Die Cast
17	1960547SM	1	LOCKWASHER, Interl Tooth 5/8
18	2101025SM	1	WASHER, 5/8
19	1701011SM	5	TIE, Self Locking
20	1716951SM	1	SWITCH, Headlight
21	1724588SM	1	COVER, Terminal Red
22	2860433SM	1	NUT, Hex Flange
23	1713534SM	1	INSULATOR, Battery
24	1716333SM	1	CABLE
25	1686714SM	1	BATTERY, 12 Volt, 6 Cell, 500 Amps CCA
26	1722009SM	1	STRAP
27	1717001SM	1	CABLE
28	1929000SM	1	SCREW, Hex Washer Head Taptite, 1/4-20 x 3/8
29	1726810ASM	1	BRACKET, Switch Mounting
30	1732004SM	1	SWITCH, Push Button, Reverse Pedal
31	1732006SM	1	SWITCH, Push Button, Foot Pedal
32	1717050SM	1	SWITCH, Cruise Control
33	2860665SM	5	SCREW, Pan Head Torx #10-32 x 1/2
34	1686921SM	1	SENDER, Fuel Tank
35	1722309SM	1	PLUG, Hole
36	1685303SM	1	GASKET
37	1725302SM	1	POWER OUTLET, 12 Volt
38	1718981SM	1	SWITCH, Operator Present, Seat
39	1730192SM	1	HARNESS, Wiring w/12 Volt
39	1733220SM	1	HARNESS, Wiring w/12 Volt & Electric HOC
40	1734025SM	1	WIRING ASSEMBLY, All Conditions Shutdown (CE/Export)

Footnotes

The above parts group applies to the following Mfg. Nos.:

2690735 - Prestige

Hood, Grille & Dash Group

986608

NOTE: Unless noted otherwise,
use the standard hardware torque
specification chart.

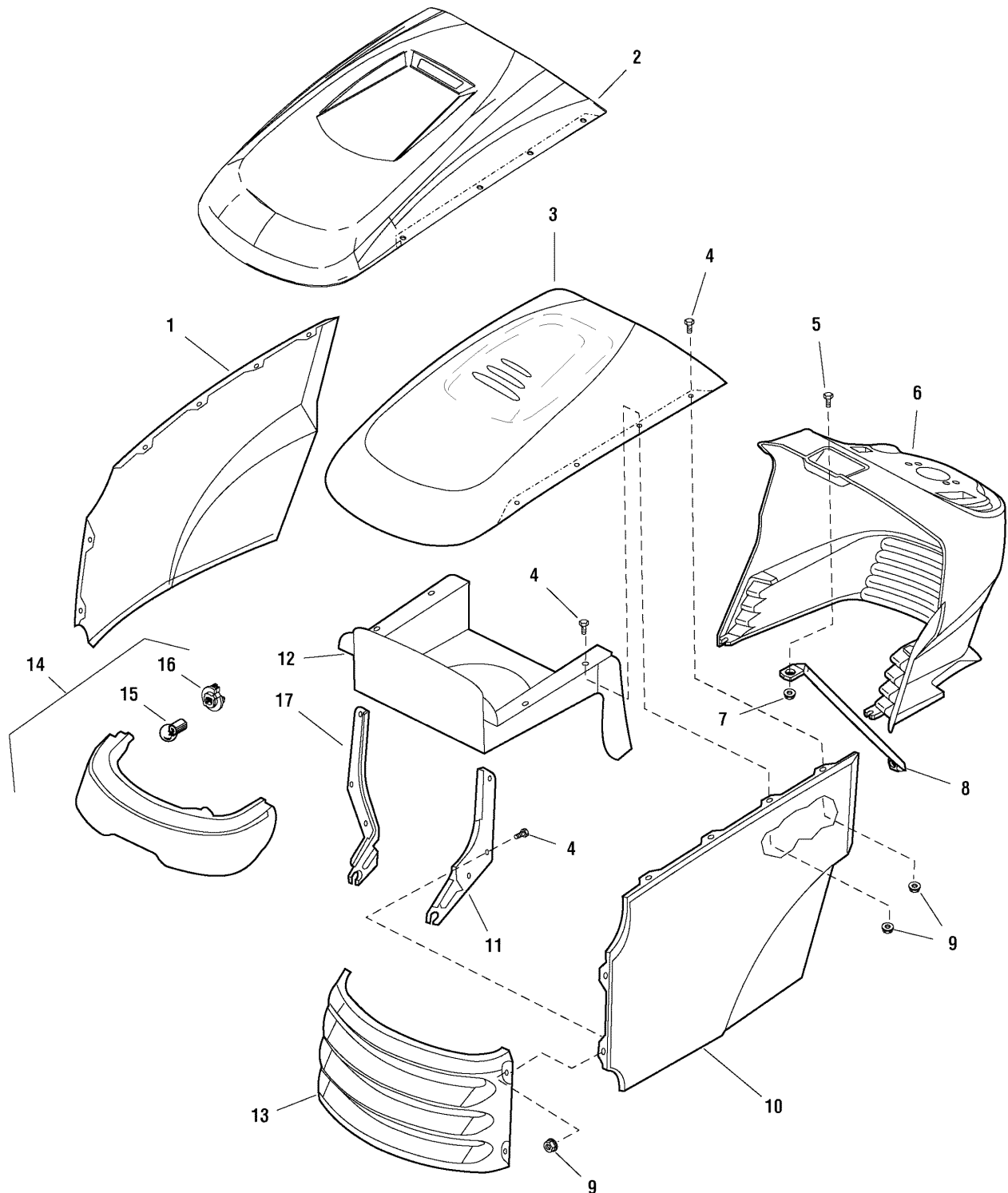

The above parts group applies to the following Mfg. Nos.:

2690735 - Prestige

Hood, Grille & Dash Group

REF NO	PART NO.	QTY.	DESCRIPTION
1	1721804CSM	1	PANEL, RH Side
1	1721804DSM	1	PANEL, RH Side, Red
2	1728031DSM	1	HOOD, with Scoop, Red
3	1722110CSM	1	HOOD, with Louvers
4	1960295SM	12	CAPSCREW, Hex Head Flange Lock, 1/4-20 x 5/8
5	1960392SM	1	SCREW, Phillips Head, #10-24 x 1/2
6	1687054SM	1	DASHBOARD, RMO, Black
6	1687055SM	1	DASHBOARD, RMO with Hydra Lift Slot, Black
7	1933896SM	1	NUT, Hex Nylock, #10-24
8	1723123SM	1	ROD, Dash Support
9	1930641SM	12	NUT, Hex Flange Lock, 1/4-20
10	1721803CSM	1	PANEL, LH Side
10	1721803DSM	1	PANEL, LH Side, Red
11	1721808ASM	1	HINGE, LH
12	1733457ASM	1	DUCT, Air Inlet
13	1721802CSM	1	GRILLE
13	1721802DSM	1	GRILLE, Red
14	1721810SM	1	HEADLIGHT ASSEMBLY (Includes Ref. Nos. 15 & 16)
15	1677371SM	4	BULB, Headligh
16	1723451SM	4	SOCKET, Headlight
17	1721809ASM	1	HINGE, RH

Footnotes

The above parts group applies to the following Mfg. Nos.:

2690735 - Prestige

Seat & Seat Deck Group

985909

NOTE: Unless noted otherwise,
use the standard hardware torque
specification chart.

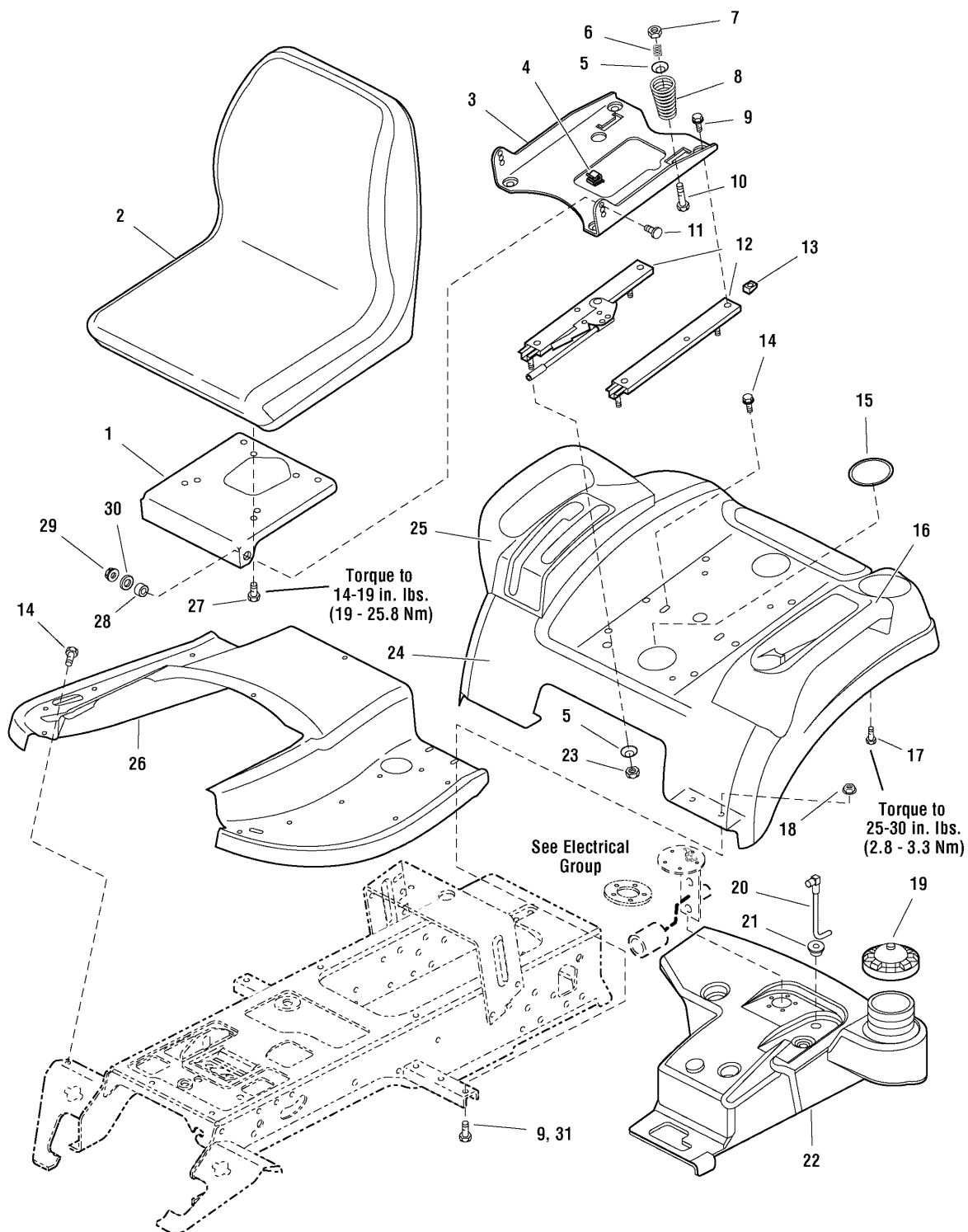

The above parts group applies to the following Mfg. Nos.:

2690735 - Prestige

Seat & Seat Deck Group

REF NO	PART NO.	QTY.	DESCRIPTION
1	1722129ASM	1	BRACKET, 1-5/8 x 1-3/4
2	1687199SM	1	SEAT, 18" Back
3	1722128ASM	1	SUPPORT, Seat
4	2172434SM	1	CLIP, Wire
5	1709256SM	2	WASHER, Spring, 5/16 x 1-1/4
6	1714263SM	2	SPRING, Compression
7	1919438SM	10	NUT, Hex Lock, ESNA Light, 5/16-18
8	1717051SM	2	SPRING, Compression
9	1930591SM	8	CAPSCREW, Hex Flange Whiz Lock, 5/16-18 x 3/4
10	1931339SM	2	CARRIAGE BOLT, 5/16-18 x 2
11	1931350SM	2	CARRIAGE BOLT, 3/8-16 x 1
12	1722356SM	1	SLIDE, Seat
13	1935255SM	4	NUT, Speed, 5/16-18, Lug Type
14	1930601SM	4	CAPSCREW, Hex Washer Head Taptite, 5/16-18 x 5/8
15	1722309SM	2	PLUG, Plastic
16	1729711SM	1	POD, with Cup Holder, LH
17	2860664SM	8	CAPSCREW, Hex Washer Head, 1/4-20 x 5/8
18	1931277SM	4	NUT, Hex Flange Whiz Lock, 5/16-18
19	1715917SM	1	CAP, Gas
20	1722340SM	1	TUBE & ELBOW ASSEMBLY
21	1654930SM	1	BUSHING, 3/8 x 9/16 x 5/8, Rubber
22	1722432SM	1	TANK, Fuel
23	1960636SM	8	NUT, Hex KEPS, 5/16-18
24	1722106CSM	1	DECK, Seat, Orange
24	1722106DSM	1	DECK, Seat, Red
25	1722108SM	1	POD, RH with 2 Slots
26	1722105CSM	1	TUNNEL, Orange
26	1722105DSM	1	TUNNEL, Red
27	1960667SM	4	SCREW, Hex Flange Whiz Lock, 5/16-18 x 1
28	1663752SM	2	SPACER, 25/64 x 5/8 x 3/16, Hardened
29	1930645SM	2	NUT, Hex Flange Two-Way Lock, 3/8-16
30	1924940SM	2	WASHER, 3/8
31	1930595SM	4	SCREW, Taptite 5/16-18 x 1-1/4

Footnotes

The above parts group applies to the following Mfg. Nos.:

2690735 - Prestige

Lift Group - Hydraulic Lift with Power Steering

987427

NOTE: Unless noted otherwise,
use the standard hardware torque
specification chart.

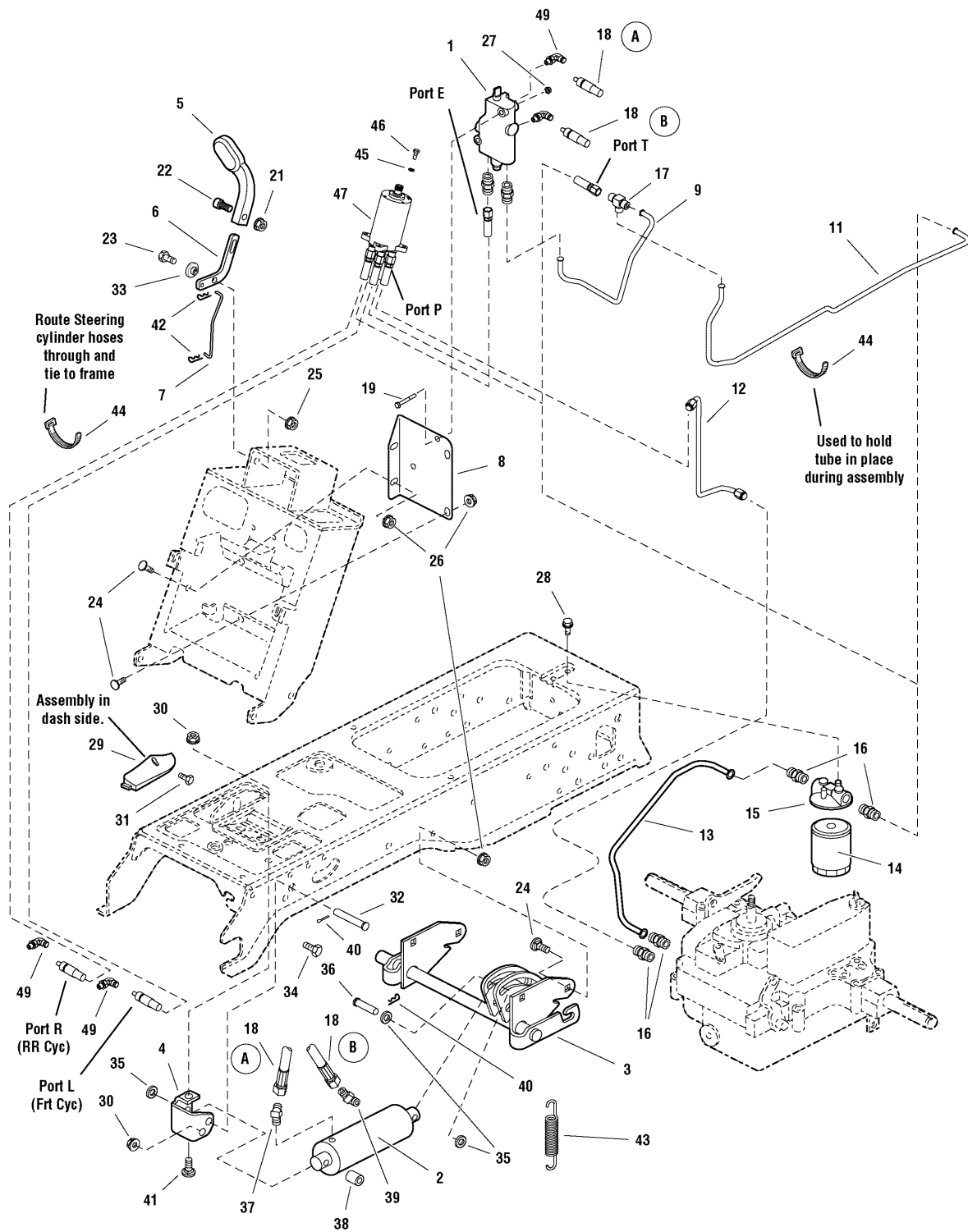

The above parts group applies to the following Mfg. Nos.:
2690735 - Prestige

Lift Group - Hydraulic Lift with Power Steering

REF NO	PART NO.	QTY.	DESCRIPTION
1	1717558SM	1	VALVE, Control
2	1722266SM	1	CYLINDER, Hydraulic
3	1727436ASM	1	SHAFT ASSEMBLY, Lift
4	1722113ASM	1	SUPPORT, Cylinder
5	1722146SM	1	HANDLE, Lift
6	1721901SM	1	LEVER, Hydraulic
7	1727557SM	1	ROD, Curved Link
8	1721904ASM	1	SUPPORT, Control
9	1722135SM	1	TUBE, Hydraulic
11	1722138SM	1	TUBE, Hydraulic
12	1733727SM	1	TUBE, Hydraulic 3 Bends
13	1733427SM	1	TUBE, Hydraulic (Used only on 4WD Hydro Lift units)
13	1722297SM	1	TUBE, Hydraulic
14	1719168SM	1	FILTER, Oil
15	1719169SM	1	BASE, Oil Filter
16	1722123SM	4	FITTING, Straight
17	1733211SM	1	FITTING, Tee, 3 Ports / Hydraulic Hose
18	1733216SM	2	HOSE ASSEMBLY, Hydraulic
19	1921963SM	2	CAPSCREW, Hex Head, 1/4-20 x 2 G5
21	1920397SM	1	NUT, Hex Lock ESNA Light 1/4-20
22	1960666SM	1	SCREW, Torx Plus Socket Head 1/4-20 x 7/8
23	1921333SM	1	CAPSCREW, Hex Head 5/16-18 x 1 G5
24	1931333SM	8	CARRIAGE BOLT, 5/16-18 x 3/4 G5
25	1919438SM	1	NUT, Hex Lock ESNA Light 5/16-18
26	1960636SM	8	NUT, Hex KEPS 5/16-18
27	2828372SM	2	NUT, Hex KEPS 1/4-20
28	1931646SM	2	SCREW, Hex Whiz Lock Flange, 1/4-20 x 1/2
29	1722285SM	1	COVER, Dash ABS (SEE NARRATIVE)
30	1960637SM	2	NUT, Hex KEPS 3/8-16
31	1722607SM	1	SCREW, Pan Head Torque, #8-16 x 1/2, Plastite
32	1722147SM	1	PIN, Clevis
33	1723244SM	1	SPACER, Hydraulic Lift Pivot
34	1921210SM	1	CAPSCREW, Hex Head 3/8-16 x 1 G5
35	1960027SM	3	WASHER, 1/2
36	1722819SM	1	PIN, Flat Head Drilled
37	1722122SM	1	FITTING, Elbow 1/2
38	1722148SM	1	SPACER
39	1722141SM	1	FITTING, Elbow 1/2
40	1960033SM	2	CLIP, Hair Pin
41	1931350SM	1	CARRIAGE BOLT, 3/8-16 x 1 G5
42	1923360SM	2	PIN, Cotter 5/8 x 3/4
43	2156302SM	1	SPRING, Extension
44	1701011SM	2	TIE, Self Locking
45	1916964SM	4	LOCKWASHER, Spring 1/4
46	2860444SM	4	CAPSCREW, Hex Head

Footnotes

The above parts group applies to the following Mfg. Nos.:

2690735 - Prestige

Lift Group - Hydraulic Lift with Power Steering

987427

NOTE: Unless noted otherwise,
use the standard hardware torque
specification chart.

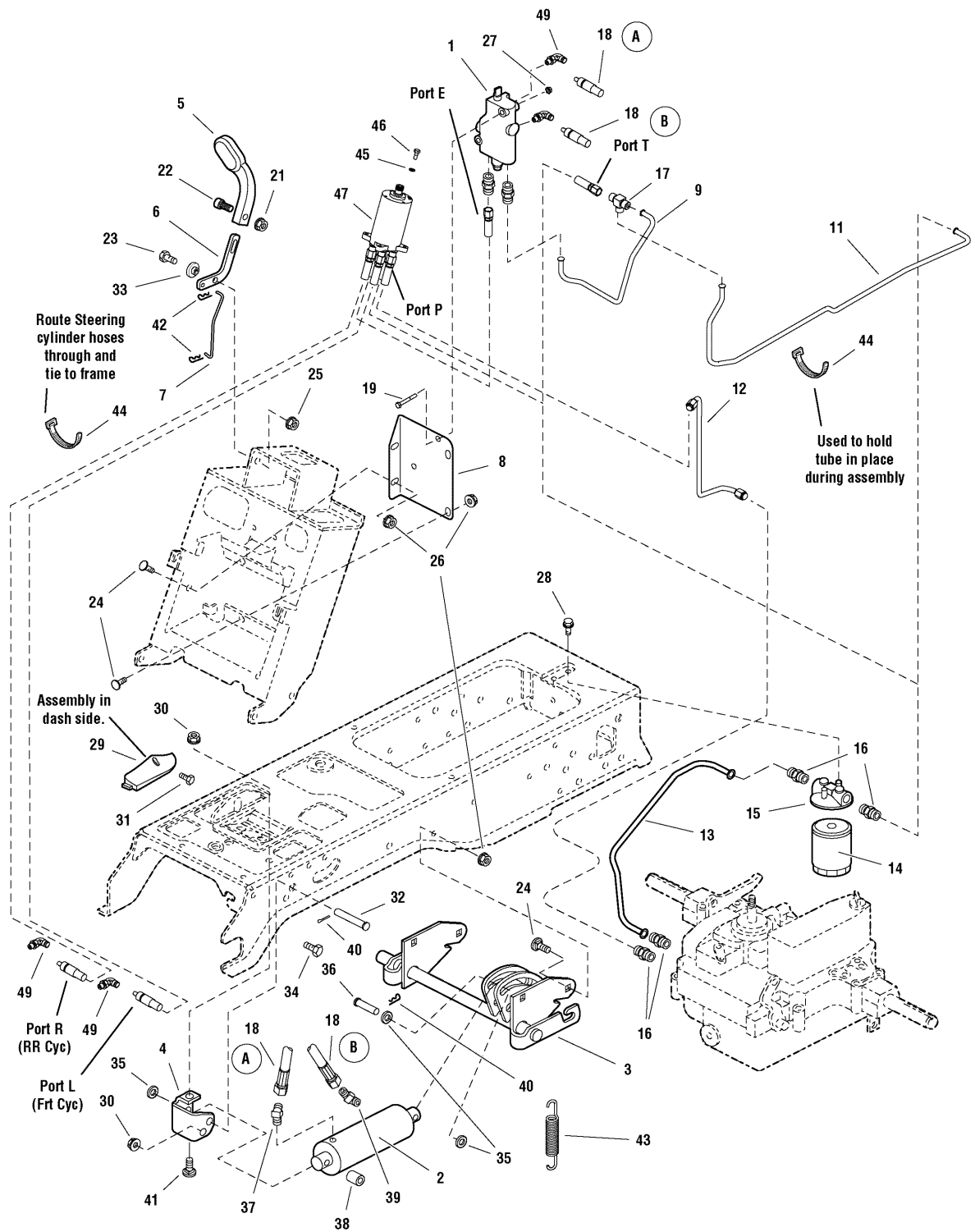

The above parts group applies to the following Mfg. Nos.:
2690735 - Prestige

Lift Group - Hydraulic Lift with Power Steering

REF NO	PART NO.	QTY.	DESCRIPTION
47	1733506SM	1	POWER STEERING UNIT, w/Hoses
47	1734134SM	1	POWER STEERING UNIT, w/Hoses (Used only on 4WD Hydro Lift units)
49	1733230SM	4	FITTING, Hose Elbow Perma Push 9/16-18

Footnotes

The above parts group applies to the following Mfg. Nos.:

2690735 - Prestige

Wheels & Tires Group

NOTE: Unless noted otherwise,
use the standard hardware torque
specification chart.

W987904

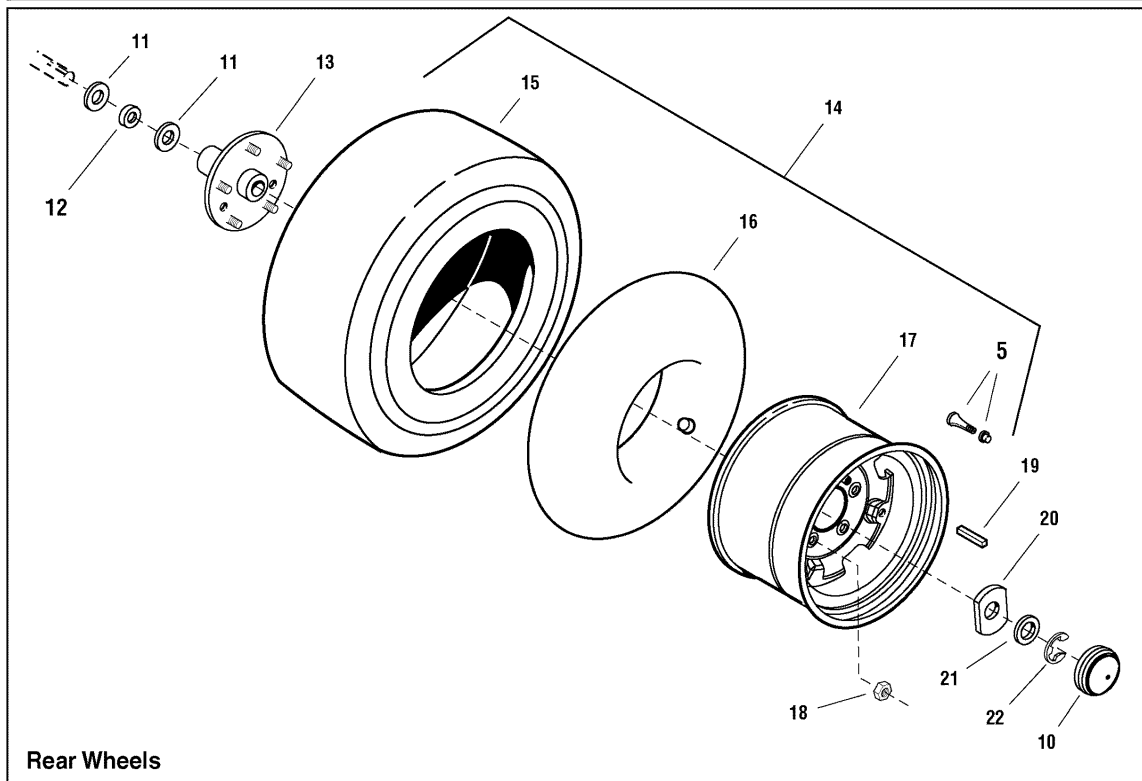
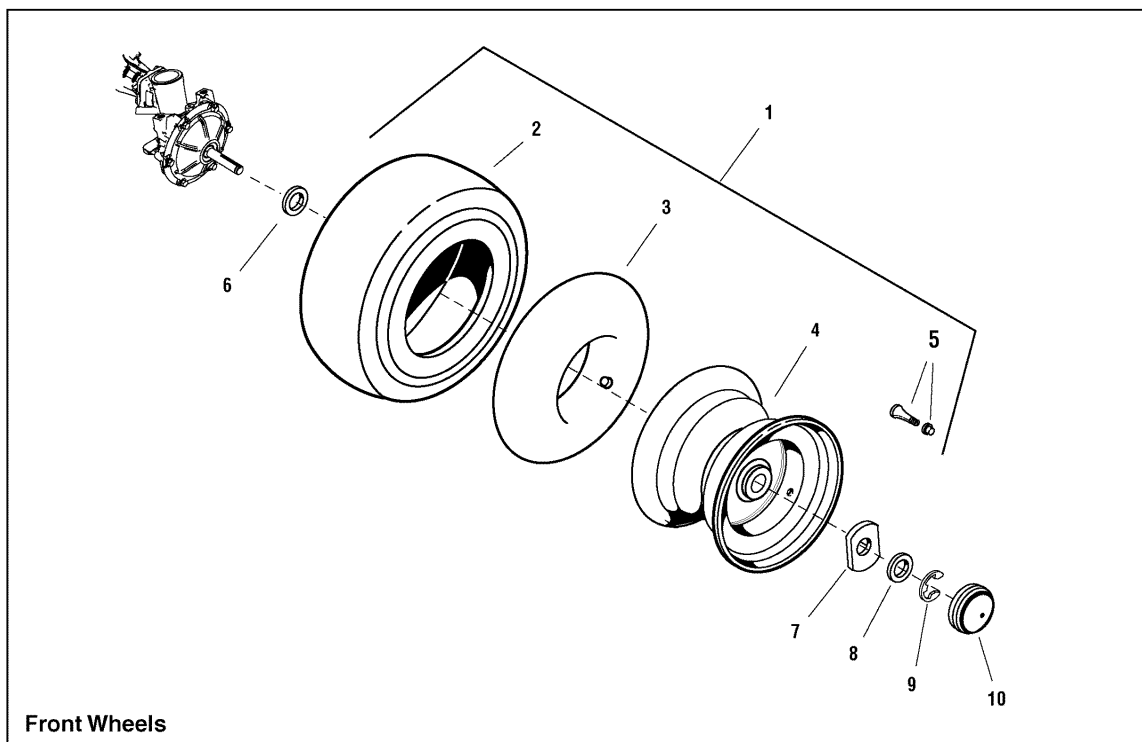

The above parts group applies to the following Mfg. Nos.:

2690735 - Prestige

Wheels & Tires Group

REF NO	PART NO.	QTY.	DESCRIPTION
1	1735010SM	2	WHEEL & TIRE ASSEMBLY (Includes Ref. Nos. 2, 3, 4 & 5)
2	1735706SM	2	TIRE, 16 x 6-1/2-8
3	2153038SM	2	TUBE, Tire
4	1733237SM	2	WHEEL ASSEMBLY
5	2172353SM	4	VALVE STEM & CAP
6	2860202SM	2	WASHER, Flat 3/4 x 1-5/8 x 1/8
7	1722717ASM	2	WASHER, Flat
8	1960114SM	2	WASHER, 3/4
9	2827794SM	2	RING
10	1722676SM	4	CAP, Hub
11	1960701SM	4	WASHER, 1 x 2-1/4 x 1/8
12	1726089SM	2	SPACER
13	1721400SM	2	PLATE & HUB WELDMENT
14	1735011SM	2	WHEEL & TIRE ASSEMBLY (Includes Ref. Nos. 5, 15, 16 & 17)
15	1735705SM	2	TIRE, 23 x 10-1/2-12
16	2157638SM	2	TUBE, Tire
17	1722831SM	2	WHEEL
18	2177725SM	10	NUT, Hex 7/16-20 For Wheel Bolt
19	2105337SM	2	KEY, Hi-Pro 1/4 x 2
20	1722726ASM	2	WASHER, Flat
21	1919394SM	2	WASHER, Flat
22	2834712SM	2	RING

Footnotes

The above parts group applies to the following Mfg. Nos.:

2690735 - Prestige

Decals Group

NOTE: Unless noted otherwise, use the standard hardware torque specification chart.

D987904

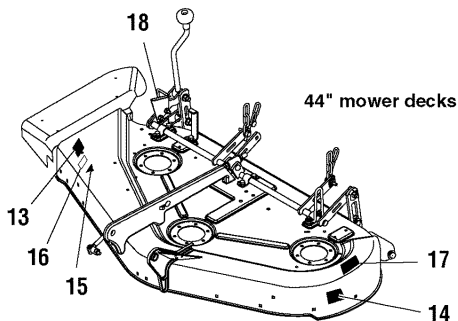
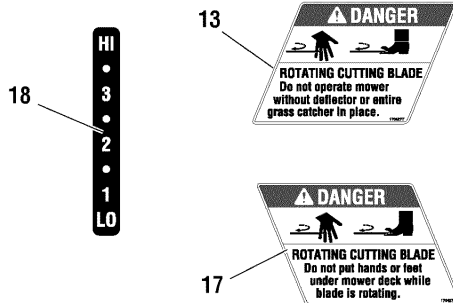
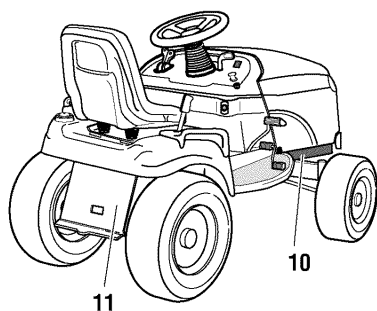
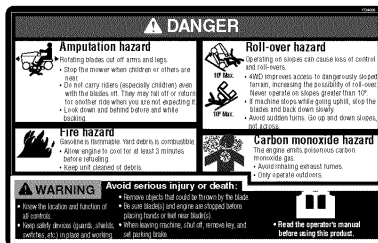
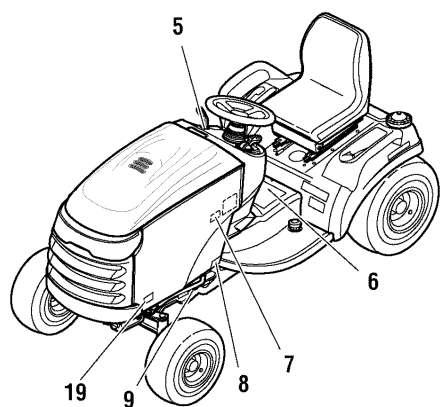
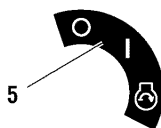
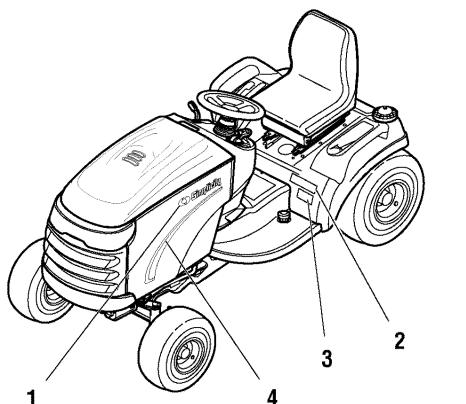

44" mower decks

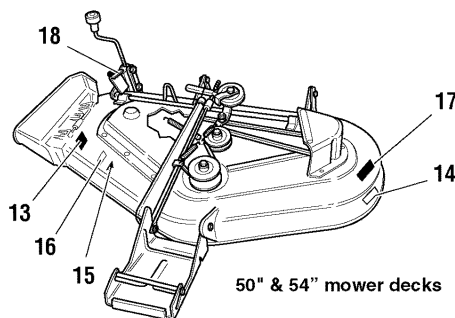

50" & 54" mower decks

The above parts group applies to the following Mfg. Nos.:
2690735 - Prestige

Decals Group

REF NO	PART NO.	QTY.	DESCRIPTION
1	1722551SM	3	DECAL, Simplicity Silver & Blue w/Icon
2	1722821SM	1	DECAL, Prestige, Silver & Blue
3	1733190SM	1	DECAL, 27HP Silver on Clear
4	1722773SM	1	DECAL, Hood Stripe R.H. SMI Blue & Silver
4	1722774SM	1	DECAL, Hood Stripe L.H. SMI Blue & Silver
5	1722806SM	1	DECAL, Ignition Switch Symbols
6	1734026SM	1	DECAL, Tunnel Cover Danger Slopes, Blades
7	1734142SM	1	DECAL, Touch Up Paint
8	1723296SM	2	STICKER, Protection
9	*	1	DECAL, I.D. Plate
10	*	1	DECAL, Patent
11	1723160SM	1	DECAL, Transmission Release Valve
13	1704277SM	1	DECAL, Danger Do Not Operate w/o Deflector
14	1722771SM	1	DECAL, Free Floating Mower (Only used on 44" & 54" Mower Decks)
15	*	1	DECAL, OPEI Certified
16	1722789SM	1	DECAL, 44" Silver on Black w/Stripe
16	1722790SM	1	DECAL, 50" Silver on Black w/Stripe
16	1722791SM	1	DECAL, 54" Silver on Black w/Stripe
17	1704276SM	1	DECAL, Danger Do Not Put Hand/Feet In Mower
18	1721197SM	1	DECAL, 1 2 3 4 5 6, Height of Cut White/Black
19	1726373SM	2	DECAL, 4x4

Footnotes

NOTE * Not a serviceable part.

The above parts group applies to the following Mfg. Nos.:

2690735 - Prestige

44" & 50" Mower Deck - Clutch & Support Group

987599

NOTE: Unless noted otherwise,
use the standard hardware torque
specification chart.

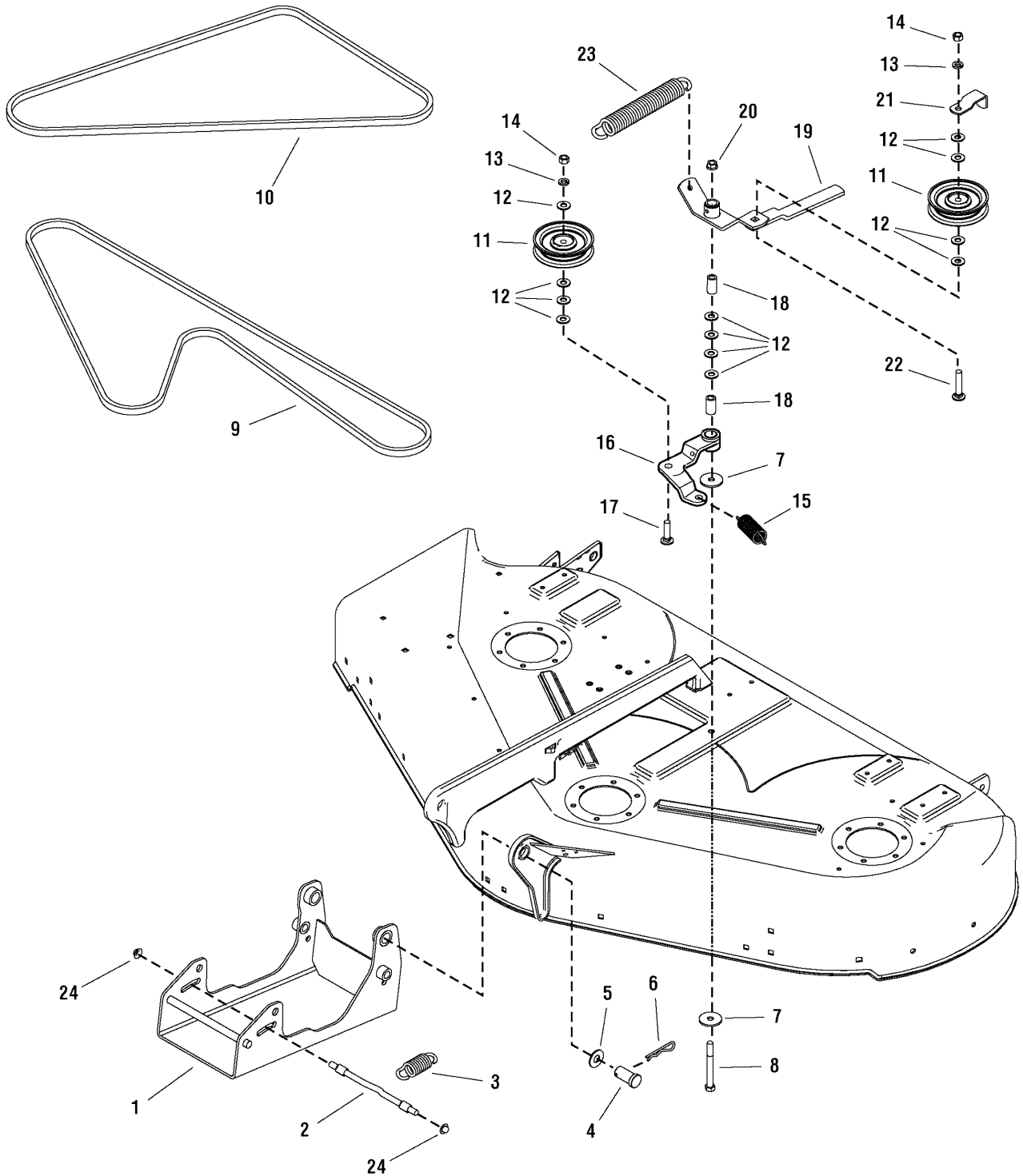

The above parts group applies to the following Mfg. Nos.:

- 1695390 - 50" Mower
- 1695424 - 44" Mower

44" & 50" Mower Deck - Clutch & Support Group

REF NO	PART NO.	QTY.	DESCRIPTION
1	1732977ASM	1	HITCH & RODS ASSEMBLY, 4WD
2	1715759SM	1	ROD
3	2156302SM	1	SPRING, Extension
4	1733830SM	2	PIN, Clevis
5	2860202SM	2	WASHER, 3/4
6	1960033SM	2	CLIP, Hair Pin
7	1924356SM	2	WASHER, 3/8
8	1923938SM	1	CAPSCREW, Hex Head 3/8-15 x 3-1/2 G5
9	1703836SM	1	V-BELT, Arbor Drive (Used only on 50" Mower)
9	1721532SM	1	V-BELT, Arbor Drive (Used only on 44" Mower)
10	1734114SM	1	V-BELT, Mower Drive 70.1 (Used only on 50" Mower)
10	1734115SM	1	V-BELT, Mower Drive 62.1 (Used only on 44" Mower)
11	1724387SM	2	PULLEY, Idler
12	1924940SM	12	WASHER, 3/8
13	1916965SM	2	LOCKWASHER, Spring 3/8
14	1916950SM	2	NUT, Hex 3/8-16
15	1656936SM	1	SPRING, Extension
16	1718561SM	1	LEVER ASSEMBLY, Idler w/Bushing & Fitting
17	1931352SM	1	CARRIAGE BOLT, 3/8-16 x 1-1/2 G5
18	1674669SM	2	SPACER
19	1704658SM	1	LEVER ASSEMBLY, Idler w/Bushings & Fitting
20	1960339SM	1	NUT, Hex Flange 3/8-16 Machine Lock
21	1677135ASM	1	GUARD, Belt
22	1960315SM	1	CARRIAGE BOLT, 3/8-16 x 2 G5
23	1715435SM	1	SPRING, Extension
24	1960093SM	2	NUT, Push Pal 3/8 Diameter Stud Capped

Footnotes

The above parts group applies to the following Mfg. Nos.:

1695390 - 50" Mower

1695424 - 44" Mower

44" Mower Deck - Electric Height Adjustment & Roller Bar Group

NOTE: Unless noted otherwise,
use the standard hardware torque
specification chart.

2987927

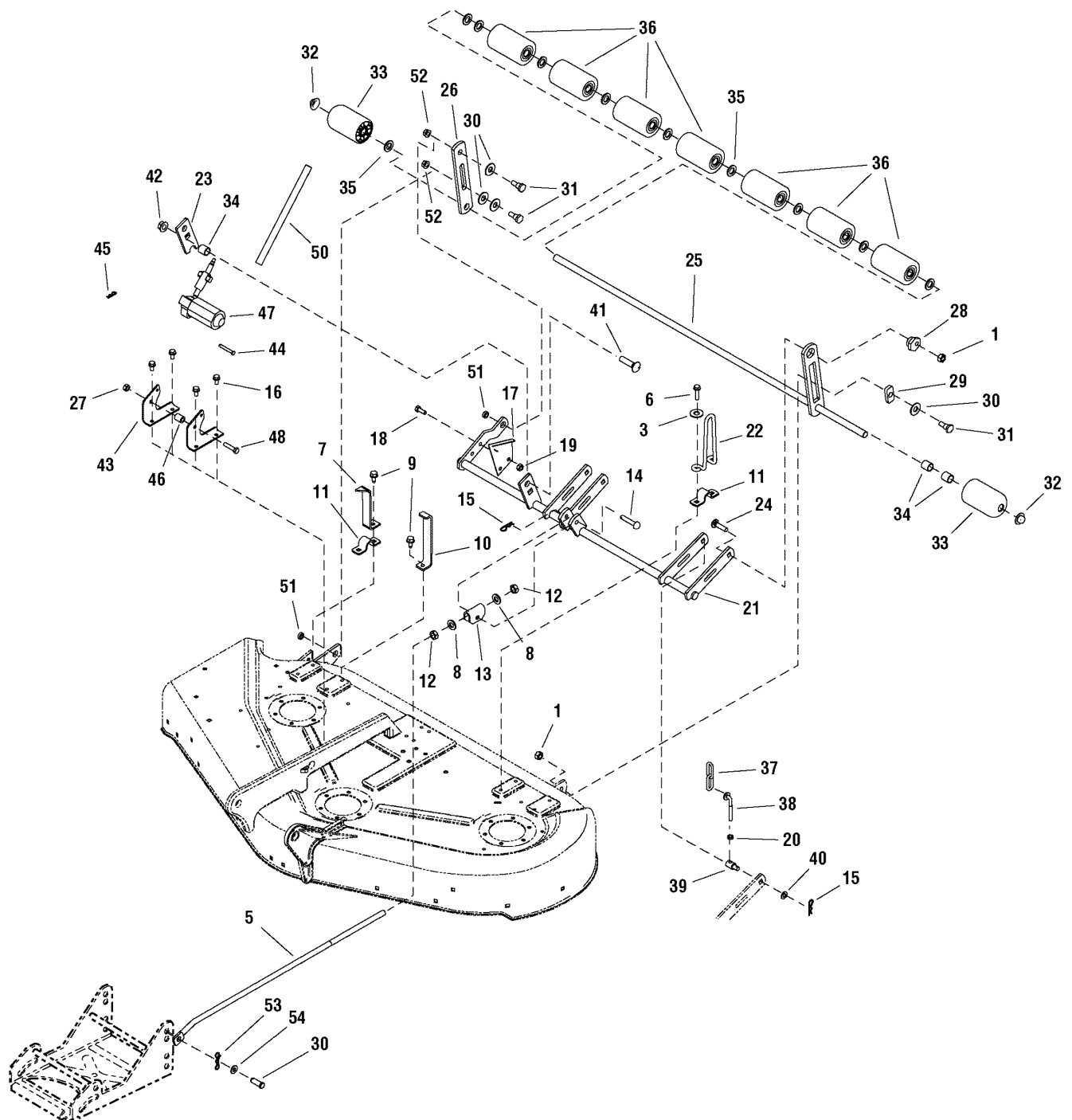

The above parts group applies to the following Mfg. Nos.:

1695424 - 44" Mower

44" Mower Deck - Electric Height Adjustment & Roller Bar Group

REF NO	PART NO.	QTY.	DESCRIPTION
1	2860681SM	2	LOCKNUT, Security 3/8-16
3	1924940SM	2	WASHER, 3/8
5	1734797SM	1	ROD, Adjustment
6	1931202SM	2	SCREW, Hex Washer Head Taptite 5/16-18 x 1-1/4
7	1720643ASM	1	INDICATOR, Height
8	1960170SM	2	WASHER, 1/2
9	1664847SM	5	SCREW, Hex Washer Head Taptite 5/16-18 x 3/4
10	1722748ASM	1	BRACKET, Up-Stop
11	1665374SM	3	STRAP, Roller E-Coat
12	1913744SM	2	NUT, Hex Jam 1/2-13
13	1704081ASM	1	TRUNNION, Rod
14	2118053SM	1	PIN, Round Head Drilled 3/8 x 2
15	1960074SM	3	CLIP, Hair Pin
16	1930601SM	4	SCREW, Hex Washer Head Taptite 5/16-18 x 5/8
17	1704116ASM	1	BRACKET, Height of Cut 16GA
18	1930591SM	2	SCREW, Hex Whiz Lock Flange 5/16-18 x 3/4
19	1931277SM	2	NUT, Hex Flange 5/16-18 Whiz Lock Small
20	1920161SM	2	NUT, Hex Jam 5/16-18
21	1733521ASM	1	SHAFT ASSEMBLY, Rocker 44"
22	1722747SM	1	UP-STOP, 6-1/4 High
23	1733386ASM	1	ARM, Rear 1/2 Thick
24	1931352SM	1	CARRIAGE BOLT, 3/8-16 x 1-1/2 G5
25	1716159ASM	1	SHAFT & BAR ASSEMBLY, Roller 44"
26	1704074ASM	1	BAR, Roller 5/16
27	1927557SM	1	NUT, Hex Flange 5/16-18 Whiz Lock Large
28	1704082SM	1	NUT, Hex Adjusting
29	1677507SM	1	SLIDE
30	1924361SM	5	WASHER, 1/2
31	2172622SM	3	BOLT, Shoulder 3/8-16 G5
32	1960520SM	2	NUT, Push for 5/8 Diameter Stud Capped
33	1722036SM	2	ROLLER
34	1602946SM	3	SPACER
35	1924366SM	10	WASHER, 5/8
36	1668513SM	7	ROLLER
37	1731383ASM	2	CHAIN, Link
38	1731384SM	2	ROD, Height Adjusting 5/16-18
39	1731382SM	2	TRUNNION
40	1960103SM	1	WASHER, 3/8
41	1960706SM	1	CARRIAGE BOLT, 1/2-13 x 2 G5
42	1960689SM	1	NUT, Hex Toplock Flange 1/2-13
43	1733828ASM	2	BRACKET, Mounting 10GA
44	1668344SM	1	PIN, Shear
45	1960221SM	1	CLIP, Hairpin
46	1733068SM	1	SPACER
47	1733513SM	1	MOTOR, Electric

Footnotes

The above parts group applies to the following Mfg. Nos.:

1695424 - 44" Mower

44" Mower Deck - Electric Height Adjustment & Roller Bar Group

NOTE: Unless noted otherwise,
use the standard hardware torque
specification chart.

2987927

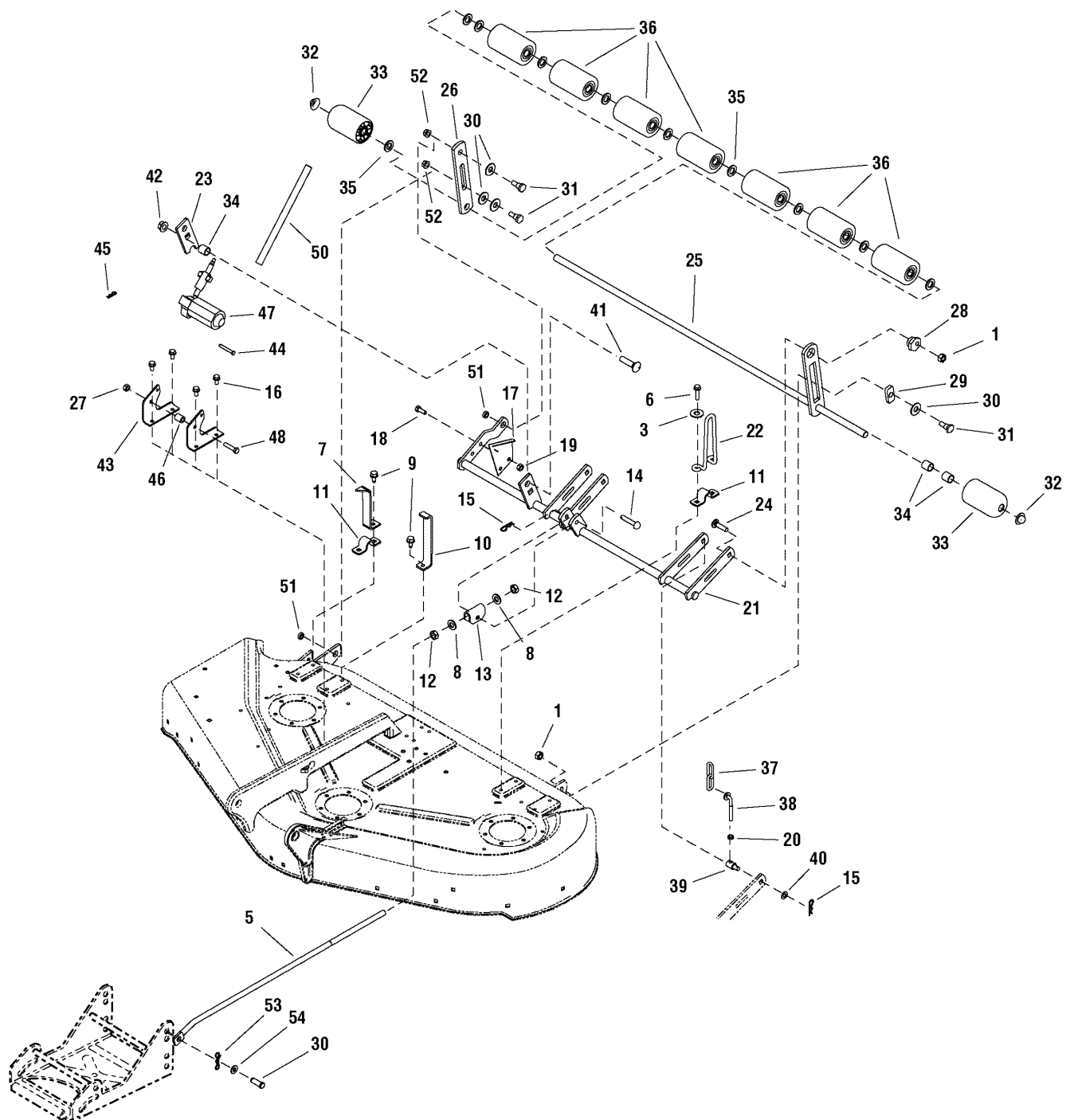

The above parts group applies to the following Mfg. Nos.:

1695424 - 44" Mower

44" Mower Deck - Electric Height Adjustment & Roller Bar Group

REF NO	PART NO.	QTY.	DESCRIPTION
50	1733895SM	1	TUBE, Flexible
51	1663752SM	2	SPACER
52	1960339SM	2	NUT, Hex Flange 3/8-16 Machine Lock Large
53	1722320SM	1	PIN, Cotter Locking
54	1960116SM	1	PIN, Yoke

Footnotes

The above parts group applies to the following Mfg. Nos.:

1695424 - 44" Mower

44" Mower Deck - Housing, Arbors & Blades Group

987515

NOTE: Unless noted otherwise, use the standard hardware torque specification chart.

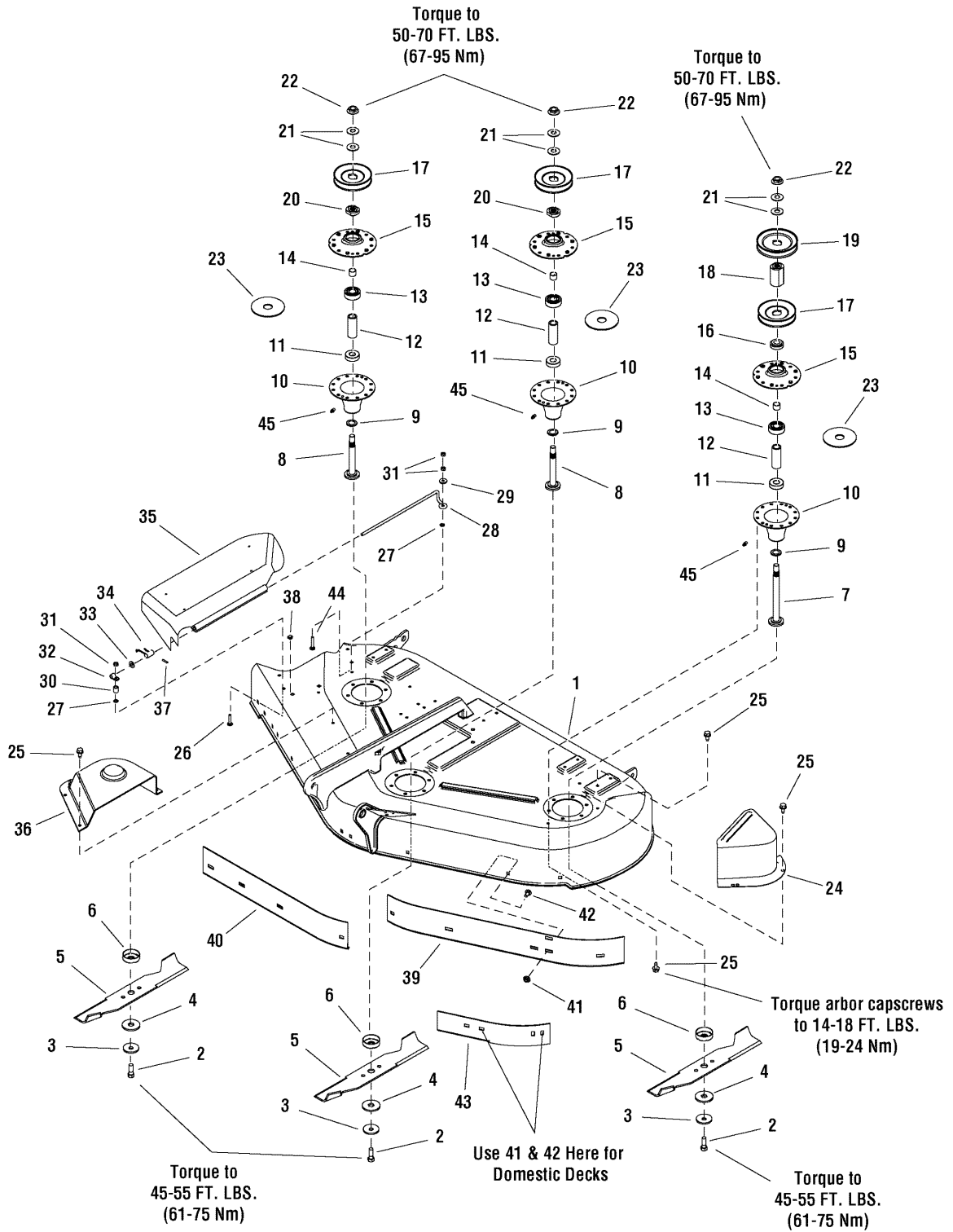

The above parts group applies to the following Mfg. Nos.:
1695424 - 44" Mower

44" Mower Deck - Housing, Arbors & Blades Group

REF NO	PART NO.	QTY.	DESCRIPTION
1	1687327SM	1	HOUSING ASSEMBLY, 44"
2	2823471SM	3	CAPSCREW, Hex Head 7/16-14 x 1-1/4 G8
3	1656916SM	3	WASHER, Spring
4	1713089SM	3	WASHER, Hex, 11/16 x 2
5	1704100SM	3	BLADE, Mower
6	1713196SM	3	SHIELD, Grass Lower Arbor Heat Treat
7	1713612SM	1	SHAFT, Arbor
8	1713195SM	2	SHAFT, Arbor
9	1713619SM	3	WASHER, Cup
10	1713338ASM	3	HOUSING, Arbor Bottom w/Lube Fitting (Includes Ref. No. 45)
11	1705897SM	3	BEARING, Ball 11/16 x 1-9/16 x 15/32
12	1732544SM	3	SPACER, Powdered Metal
13	2108202SM	3	BEARING, Ball
14	1715724SM	3	SPACER, 21/32 x 3/4 x 5/8
15	1655729ASM	3	HOUSING, Arbor Top
16	1713533SM	1	HUB, Powdered Metal
17	1713098SM	3	PULLEY
18	1713158SM	1	HUB, Hub Serated
19	1732951SM	1	PULLEY
19	1713091SM	1	PULLEY (CE/Export)
20	1713197SM	2	HUB, Pulley, Center & R.H.
21	1713675SM	6	WASHER, Bellville
22	1714419SM	3	NUT, Hex Flange 9/16-18
23	1707335SM	3	GASKET
24	1720560ASM	1	COVER, Arbor
24	1732200ASM	1	COVER, Arbor (No Ribs) (CE/Export)
25	1664847SM	27	SCREW, Hex Washer Head Taptite 5/16-18 x 3/4
26	1960633SM	2	CARRIAGE BOLT, 1/4-20 x 1-1/2 G5
27	1960518SM	2	NUT, Push for 1/4 Diameter Thread
28	1706709SM	1	ROD, Deflector
29	1710703SM	2	SPACER
30	1931320SM	2	CARRIAGE BOLT, 1/4-20 x 1-1/4 G5
31	1920397SM	2	NUT, Hex Lock ESNA Light 1/4-20
32	1704873SM	1	CLAMP, Wire, 5/16 Diameter
33	1919326SM	1	WASHER, 5/16
34	7101082SM	1	SPRING, Torsion Chute
35	1705449SM	1	DEFLECTOR
36	1715673SM	1	COVER, Arbor
37	1931277SM	1	NUT, Hex Flange 5/16-18 Whiz Lock Small
38	1705115SM	1	PLUG, Button
39	1716879ASM	1	BAFFLE, Blowout 44" LH (CE/Export)
40	1716878ASM	1	BAFFLE, Blowout 44" RH (CE/Export)
41	1927557SM	2	NUT, Hex Flange 5/16-18 Whiz Lock Large (Quantity 11 used on CE/Export Models)
42	1921333SM	2	CAPSCREW, Hex Head 5/16-18 x 1 G5 (Quantity 11 used on CE/Export Models)
43	1724538ASM	1	BAFFLE, Short Blowout

Footnotes

The above parts group applies to the following Mfg. Nos.:

1695424 - 44" Mower

44" Mower Deck - Housing, Arbors & Blades Group

987515

NOTE: Unless noted otherwise, use the standard hardware torque specification chart.

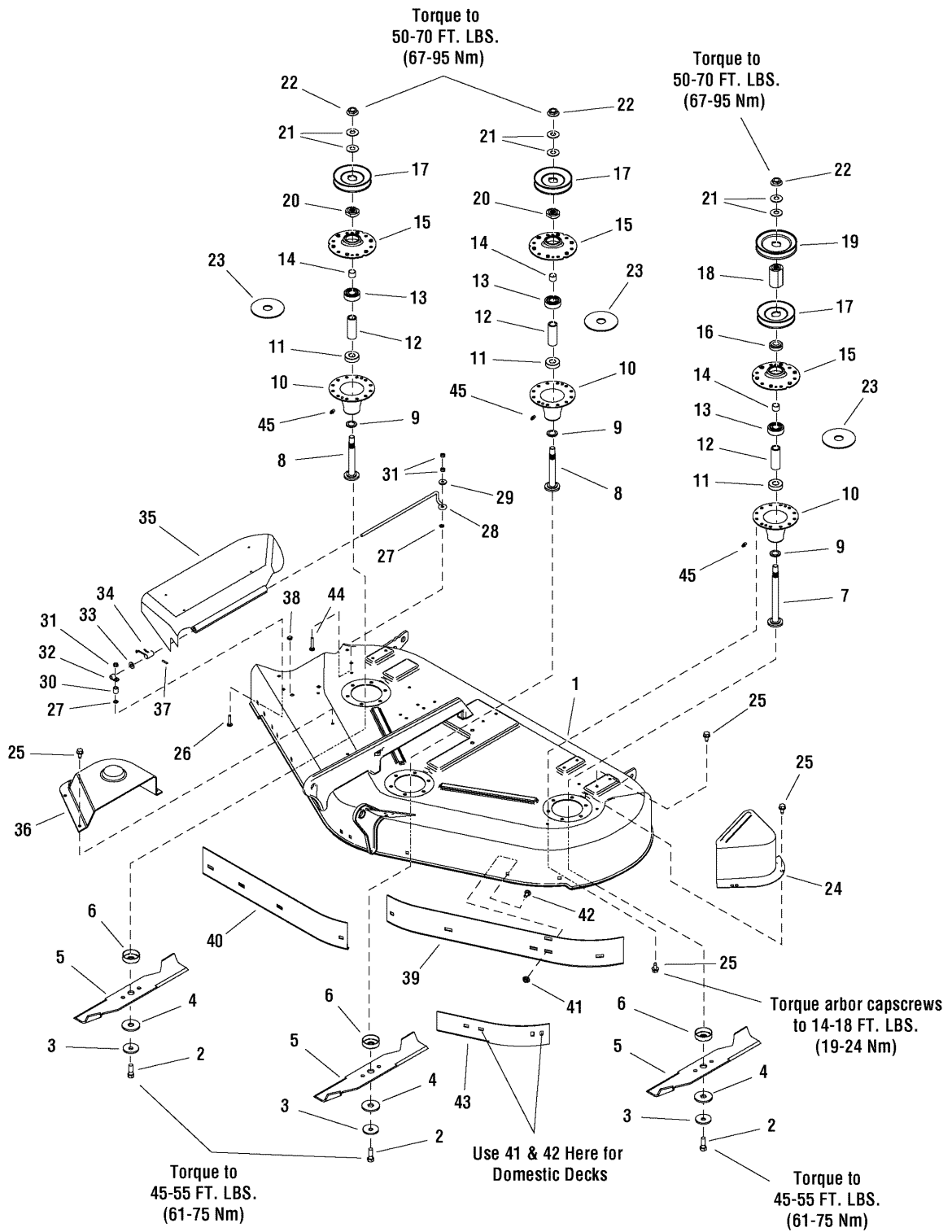

The above parts group applies to the following Mfg. Nos.:
1695424 - 44" Mower

44" Mower Deck - Housing, Arbors & Blades Group

REF NO	PART NO.	QTY.	DESCRIPTION
45	1704314SM	3	FITTING, Grease 1/4 Drive

Footnotes

The above parts group applies to the following Mfg. Nos.:

1695424 - 44" Mower

50" Mower Deck - Height Adjustment & Roller Group

REF NO	PART NO.	QTY.	DESCRIPTION
1	2860681SM	2	NUT, Hex TopLock Spiral Lock Flange 3/8-16
3	1924940SM	2	WASHER, 3/8
5	1722995SM	1	ROD, Adjusting
6	1720643ASM	1	INDICATOR, Height
7	1664847SM	6	SCREW, Hex Washer Head Taptite 5/16-18 x 3/4
8	1665374SM	3	STRAP
9	1915726SM	2	NUT, Hex 5/8-11
10	1924366SM	8	WASHER, 5/8
11	1706645ASM	1	TRUNNION
12	2118053SM	1	PIN, Round Head Drilled 3/8 x 2
13	1960074SM	3	CLIP, Hair Pin
14	1930591SM	2	SCREW, Hex Whiz Lock Flange 5/16-18 x 3/4
15	1704116ASM	1	BRACKET, Height of Cut 16GA
16	1931277SM	2	NUT, Hex Flange 5/16-18 Whiz Lock Small
18	1733386ASM	1	ARM, Rear
19	1733522ASM	1	SHAFT ASSEMBLY, Rocker 50"
20	1931352SM	1	CARRIAGE BOLT, 3/8-16 x 1-1/2 G5
21	1716155ASM	1	SHAFT & BAR ASSEMBLY, Roller
22	1704074ASM	1	BAR, Roller
23	1927557SM	1	NUT, Hex Flange 5/16-18 Whiz Lock Large
24	1704082SM	1	NUT, Hex Adjusting
25	1677507SM	1	SLIDE
26	1924361SM	5	WASHER, 1/2
27	2172622SM	3	BOLT, Shoulder 3/8-16 G5
28	1960520SM	2	NUT, Push for 5/8 Diameter Stud Capped
29	1722036SM	2	ROLLER
30	1709195SM	3	SPACER
31	1668513SM	8	ROLLER
32	1731383ASM	2	CHAIN, Link
33	1731384SM	2	ROD, Height Adjusting
34	1920161SM	2	NUT, Hex Jam 5/16-18
35	1731382SM	2	TRUNNION
36	1602946SM	1	SPACER
37	1960706SM	1	CARRIAGE BOLT, 1/2-13 x 2 G5
38	1960689SM	1	NUT, Hex Toplock Flange 1/2-13
39	1733828ASM	2	BRACKET, Mounting
40	1733068SM	1	SPACER
41	1930601SM	4	SCREW, Hex Washer Head Taptite 5/16-18 x 5/8
42	1668344SM	1	PIN, Shear
43	1960221SM	1	CLIP, Hairpin
44	1922127SM	1	CAPSCREW, Hex Head 5/16-18 x 1-3/4 G5
45	1733513SM	1	MOTOR, Electric
46	1733895SM	1	TUBE
47	1663752SM	2	SPACER
48	1960339SM	2	NUT, Hex Flange 3/8-16 Machine Lock Large

Footnotes

The above parts group applies to the following Mfg. Nos.:

1695390 - 50" Mower

50" Mower Deck - Height Adjustment & Roller Group

987888

NOTE: Unless noted otherwise,
use the standard hardware torque
specification chart.

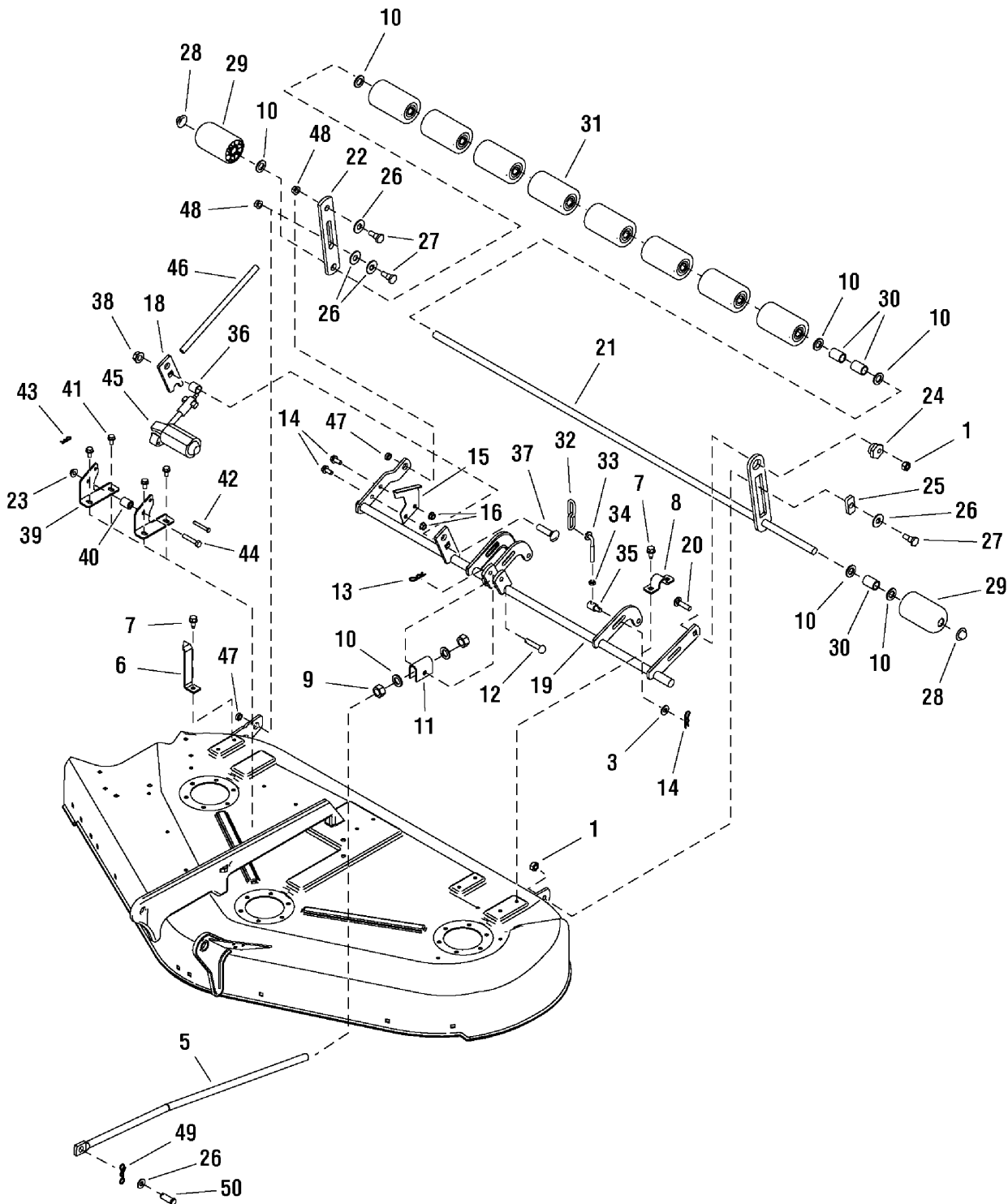

The above parts group applies to the following Mfg. Nos.:

1695390 - 50" Mower

50" Mower Deck - Height Adjustment & Roller Group

REF NO	PART NO.	QTY.	DESCRIPTION
50	1960116SM	1	PIN, Clevis 1/2

Footnotes

The above parts group applies to the following Mfg. Nos.:

1695390 - 50" Mower

50" Mower Deck - Housing, Arbors & Blades Group

987519

NOTE: Unless noted otherwise, use the standard hardware torque specification chart.

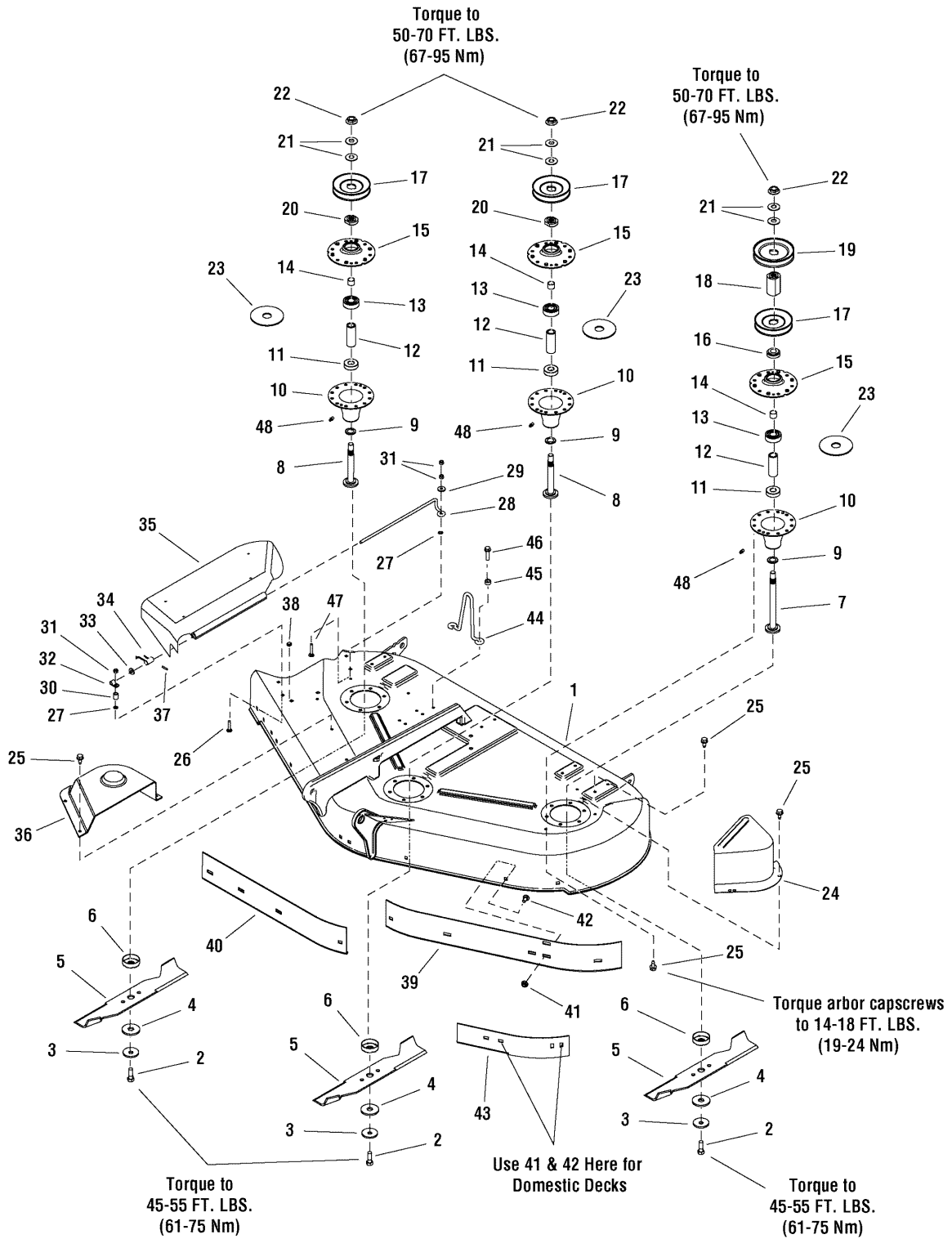

The above parts group applies to the following Mfg. Nos.:
1695390 - 50" Mower

50" Mower Deck - Housing, Arbors & Blades Group

REF NO	PART NO.	QTY.	DESCRIPTION
1	1687325SM	1	HOUSING ASSEMBLY, 50" (Orange)
1	1687326SM	1	HOUSING ASSEMBLY, 50" (Red)
2	2823471SM	3	CAPSCREW, Hex Head 7/16-14 x 1-1/4 G8
3	1656916SM	3	WASHER, Spring
4	1713089SM	3	WASHER, Hex, 11/16 x 2
5	1708229ASM	3	BLADE, Mower 50"
6	1713196SM	3	SHIELD, Grass Lower Arbor Heat Treat
7	1713612SM	1	SHAFT, Arbor
8	1713195SM	2	SHAFT, Arbor
9	1713619SM	3	WASHER, Cup
10	1713338ASM	3	HOUSING, Arbor Bottom w/Lube Fitting (Includes Ref. No. 48)
11	1705897SM	3	BEARING, Ball, 11/16 x 1-9/16 x 15/32
12	1732544SM	3	SPACER, Powdered Metal
13	2108202SM	3	BEARING, Ball
14	1715724SM	3	SPACER, 21/32 x 3/4 x 5/8
15	1655729ASM	3	HOUSING, Arbor Top
16	1713533SM	1	HUB, Powdered Metal
17	1713098SM	3	PULLEY
18	1713158SM	1	HUB, Serated Powdered Metal
19	1732951SM	1	PULLEY
20	1713197SM	2	HUB, Pulley, Center & R.H.
21	1713675SM	6	WASHER, Bellville
22	1714419SM	3	NUT, Hex Flange 9/16-18
23	1707335SM	3	GASKET, Foam Poly
24	1720560ASM	1	COVER, Arbor
25	1664847SM	27	SCREW, Hex Washer Head Taptite 5/16-18 x 3/4
26	1931320SM	2	CARRIAGE BOLT, 1/4-20 x 1-1/4 G5
27	1960518SM	2	NUT, Push for 1/4 Diameter Thread
28	1706709SM	1	ROD, Deflector E-Coat
29	1960353SM	1	WASHER
30	1710703SM	2	SPACER, Powdered Metal
31	1920397SM	2	NUT, Hex Lock ESNA Light 1/4-20
32	1704873SM	1	CLAMP, Wire
33	1919326SM	1	WASHER, 5/16
34	7101082SM	1	SPRING, Torsion Chute
35	1705449SM	1	DEFLECTOR
36	1715673SM	1	COVER, Arbor
37	1723323SM	1	CAP
38	1705115SM	1	PLUG, Button
39	1716870ASM	1	BAFFLE, Blowout 50" L.H. (CE/Export)
40	1735184ASM	1	BAFFLE, Blowout 50" R.H. (CE/Export)
41	1927557SM	2/11	NUT, Hex Flange 5/16-18 Whiz Lock Large
42	1921333SM	2/11	CAPSCREW, Hex Head 5/16-18 x 1 G5
43	1724538ASM	1	BAFFLE, Blowout (Domestic)
44	1704098SM	1	UPSTOP (Only used on Broadmoor Series)

Footnotes

The above parts group applies to the following Mfg. Nos.:

1695390 - 50" Mower

50" Mower Deck - Housing, Arbors & Blades Group

REF NO	PART NO.	QTY.	DESCRIPTION
46	1931202SM	2	SCREW, Hex Washer Taptite (Only used on Broadmoor Series)
47	1960633SM	2	CARRIAGE BOLT, 1/4-20 x 1-1/2 G5
48	1704314SM	3	FITTING, Grease, 1/4 Drive

Footnotes

The above parts group applies to the following Mfg. Nos.:

1695390 - 50" Mower

54" Mower Deck - Clutch & Support Group

987666

NOTE: Unless noted otherwise, use the standard hardware torque specification chart.

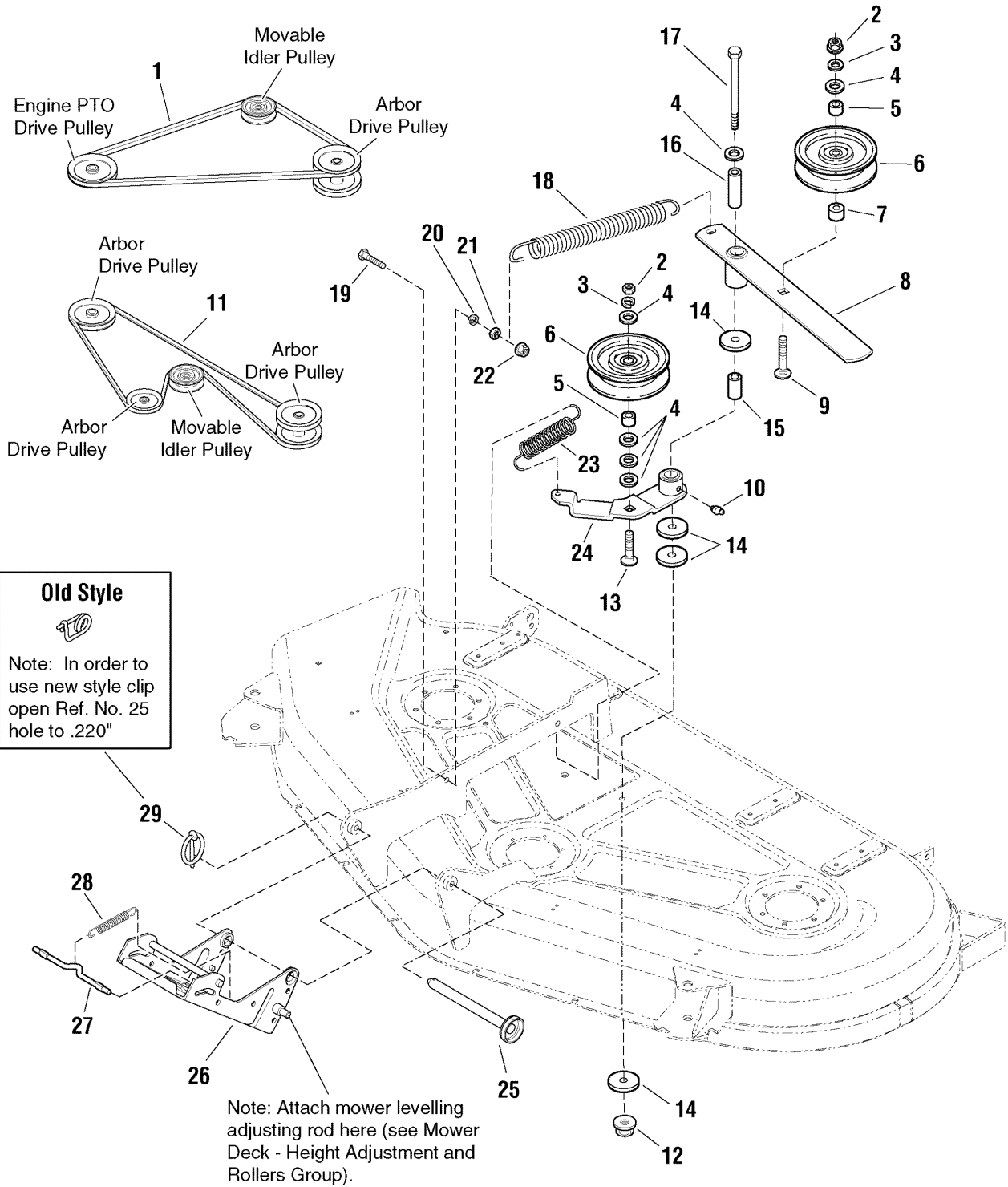

The above parts group applies to the following Mfg. Nos.:
1695266 - 54" Mower

54" Mower Deck - Clutch & Support Group

REF NO	PART NO.	QTY.	DESCRIPTION
1	1734065SM	1	V-BELT, Engine PTO
2	1916950SM	2	NUT, Hex, 3/8-16
3	1916965SM	2	WASHER, Lock, 3/8
4	1924940SM	6	WASHER, 3/8
5	1674669SM	2	SPACER
6	1724387SM	2	PULLEY
7	2157081SM	1	SPACER
8	1720379SM	1	ASSEMBLY, Lever
9	1960315SM	1	CARRIAGE BOLT, 3/8-16 x 2
10	2812808SM	1	FITTING, Lube
11	1671076SM	1	V-BELT, 54 Mower Deck
12	1960339SM	1	NUT, Hex Flange 3/8-16
13	1931352SM	1	CARRIAGE BOLT, 3/8-16 x 1-1/2
14	1924356SM	3	WASHER, 3/8
15	1674669SM	1	SPACER
16	1657242SM	1	SPACER
17	1960246SM	1	CAPSCREW, Hex Head, 3/8-16 x 4-1/2, G 5
18	1715435SM	1	SPRING
19	1921977SM	1	CAPSCREW, Hex Head, 5/16-18 x 1-1/4, G 5
20	1917356SM	1	WASHER, Lock, 5/16
21	1917372SM	1	NUT, Hex, 5/16-18
22	1923362SM	1	NUT, Hex Center-Lock 5/16-18
23	1656936SM	1	SPRING
24	1718561SM	1	ASSEMBLY, Lever
25	1720172SM	1	PIN, Hitch
26	1686873SM	1	ASSEMBLY, Hitch
27	1715759SM	1	ROD
28	2156302SM	1	SPRING
29	2176012SM	1	PIN, Safety
29	1709189SM*	1	PIN, Klik

Footnotes

The above parts group applies to the following Mfg. Nos.:

1695266 - 54" Mower

54" Mower Deck - Electric Height Adjustment & Roller Bar Group

NOTE: Unless noted otherwise,
use the standard hardware torque
specification chart.

2987667

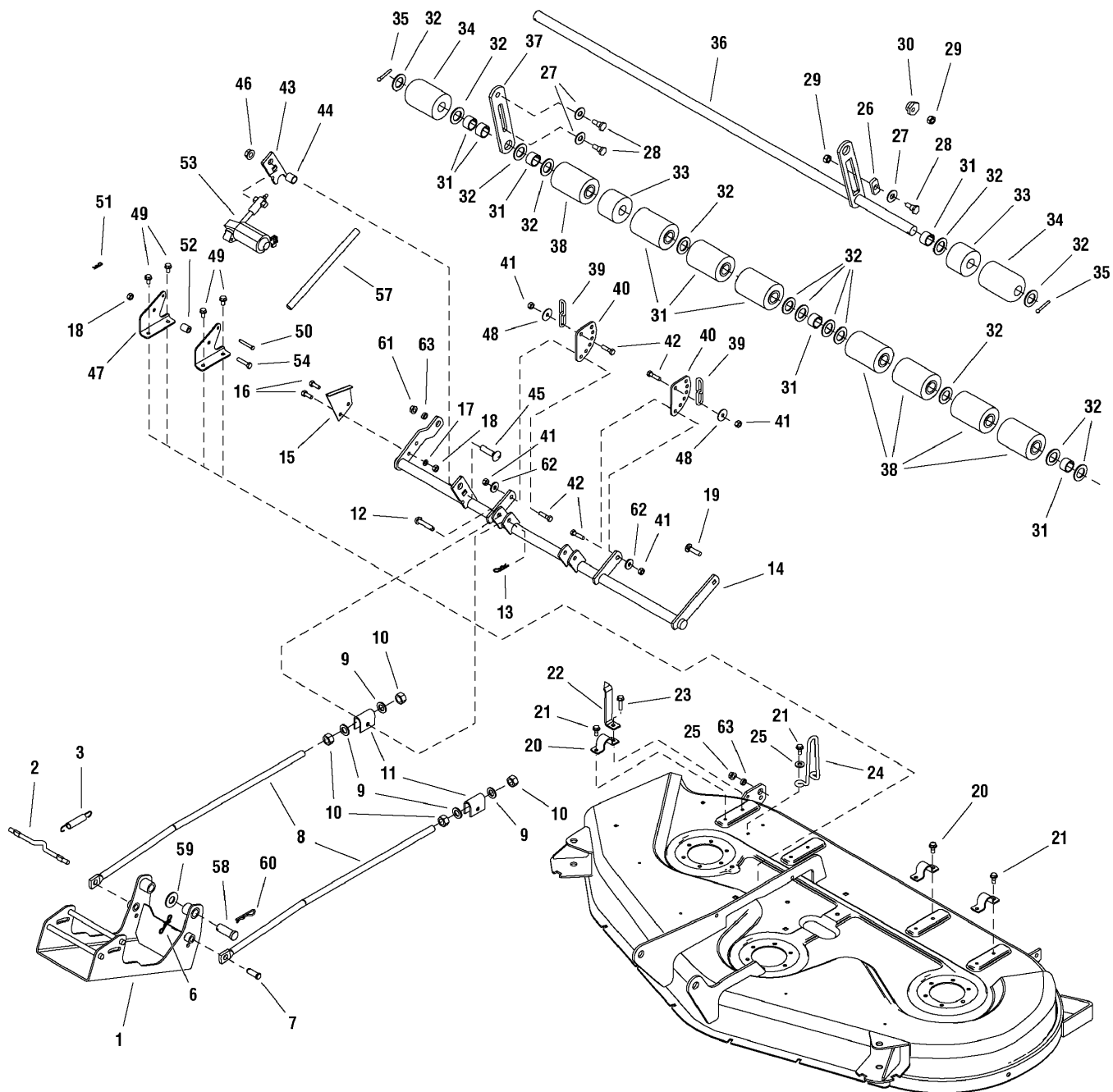

The above parts group applies to the following Mfg. Nos.:

1695266 - 54" Mower

54" Mower Deck - Electric Height Adjustment & Roller Bar Group

REF NO	PART NO.	QTY.	DESCRIPTION
1	1732977ASM	1	HITCH & ROD ASSEMBLY, 54"
2	1715759SM	1	ROD
3	2156302SM	1	SPRING, Extension
6	1722320SM	2	PIN, Cotter Locking
7	1960116SM	2	PIN, Yoke
8	1722995SM	2	ROD, Adjusting
9	1924366SM	4	WASHER, 5/8
10	1915726SM	4	NUT, Hex 5/8-11
11	1706645ASM	2	TRUNNION
12	2118053SM	2	PIN, Round Head Drilled 3/8 x 2
13	1960074SM	2	CLIP, Hair Pin
14	1733523ASM	1	SHAFT ASSEMBLY, Rocker 54"
15	1704116ASM	1	BRACKET, Height of Cut
16	1923325SM	2	CAPSCREW, Hex Head 5/16-18 x 7/8 G5
17	1917356SM	2	LOCKWASHER, Spring 5/16
18	1917372SM	3	NUT, Hex 5/16-18
19	1931352SM	1	CARRIAGE BOLT, 3/8-16 x 1-1/2 G5
20	1720147ASM	3	STRAP, Rod
21	1960541SM	7	SCREW, Hex Washer Head Taptite 5/16-18 x 3/4
22	1720643ASM	1	INDICATOR, Height
23	1931202SM	1	SCREW, Hex Washer Head Taptite 5/16-18 x 1-1/4
24	1719929SM	1	STOP, Up
25	1924940SM	4	WASHER, 3/8
26	1677507SM	1	SLIDE
27	1924361SM	4	WASHER, 1/2
28	2172622SM	3	BOLT, Shoulder, 3/8-16 G5
29	2860681SM	2	NUT, Hex Toplock Spirallock Flange 3/8-16
30	1704082SM	1	NUT, Hex Adjusting Powdered Metal
31	1701873SM	6	SPACER
32	2860626SM	14	WASHER, 1
33	1720159SM	2	ROLLER
34	1678043SM	2	ROLLER
35	1918459SM	2	PIN, Cotter
36	1723008ASM	1	SHAFT & BAR ASSEMBLY
37	1723009ASM	1	BAR, Roller
38	1678042SM	8	ROLLER W/BUSHINGS
39	1731383ASM	2	CHAIN, Link
40	1734126ASM	2	BRACKET, Roller Adjust
41	1919438SM	4	NUT, Hex Lock ESNA Light 5/16-18
42	1921977SM	2	CAPSCREW, Hex Head 5/16-18 x 1-1/4 G5
43	1733520ASM	1	ARM, Rocker
44	1602946SM	1	SPACER
45	1960706SM	1	CARRIAGE BOLT, 1/2-13 x 2 G5
46	1960689SM	1	NUT, Hex Toplock Flange 1/2-13
47	1733831ASM	2	BRACKET, Mounting

Footnotes

The above parts group applies to the following Mfg. Nos.:

1695266 - 54" Mower

54" Mower Deck - Electric Height Adjustment & Roller Bar Group

NOTE: Unless noted otherwise,
use the standard hardware torque
specification chart.

2987667

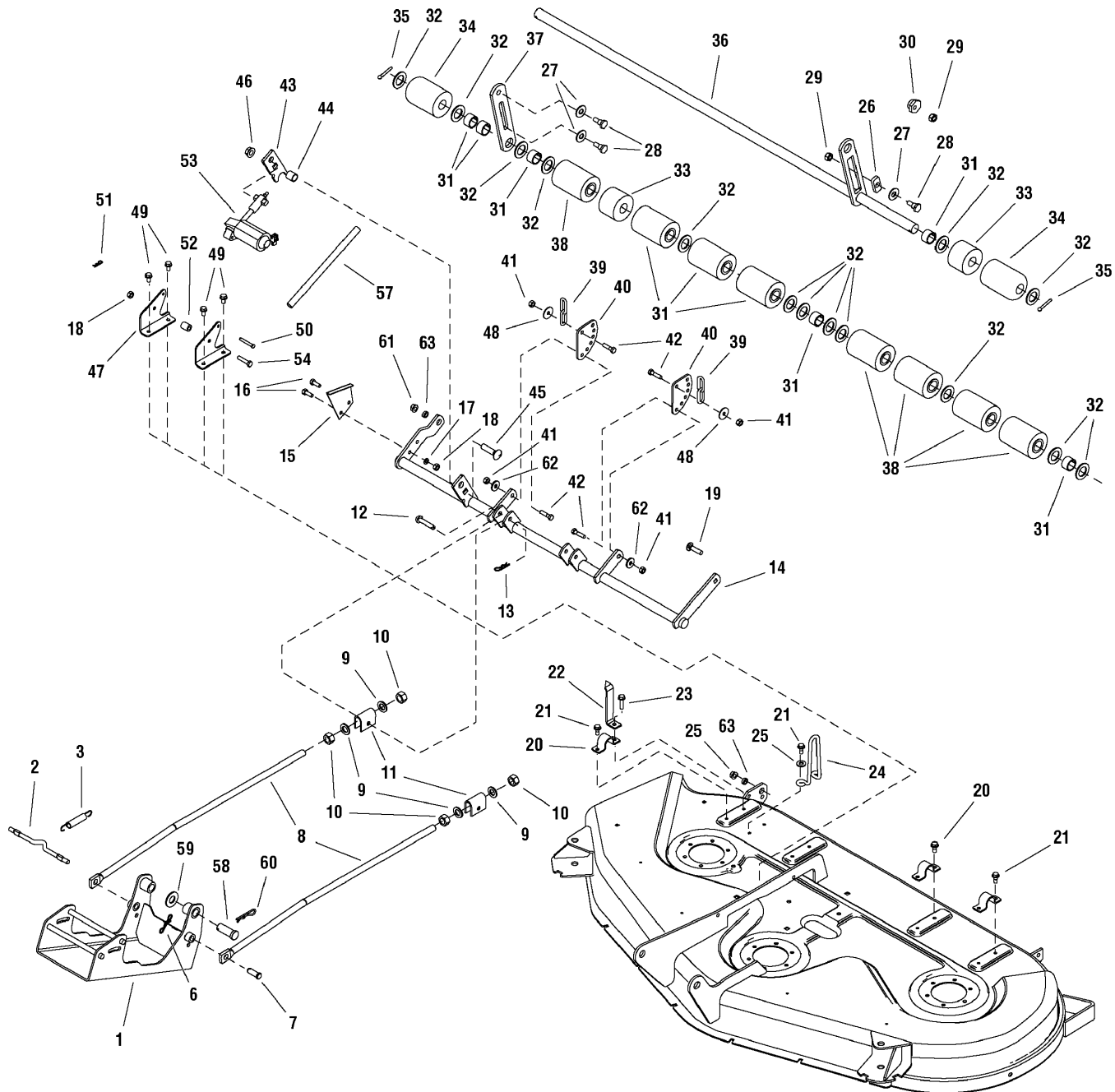

The above parts group applies to the following Mfg. Nos.:
1695266 - 54" Mower

54" Mower Deck - Electric Height Adjustment & Roller Bar Group

REF NO	PART NO.	QTY.	DESCRIPTION
49	1930601SM	4	SCREW, Hex Washer Head Taptite 5/16-18 x 5/8
50	1668344SM	1	PIN, Shear
51	1960221SM	1	CLIP, Hairpin
52	1673796SM	1	SPACER, Powdered Metal
53	1733513SM	1	MOTOR, Electric Mini Actuator
54	1921221SM	1	CAPSCREW, Hex Head 5/16-18 x 1-1/2 G5
57	1733895SM	1	TUBE, Flexible
58	1733830SM	2	PIN, Clevis
59	2860202SM	2	WASHER, 3/4
60	1960033SM	2	CLIP, Hair Pin
61	1960339SM	2	NUT, Hex Flange 3/8-16 Machine Lock
62	1919381SM	2	WASHER, 5/16
63	1663752SM	2	SPACER

Footnotes

The above parts group applies to the following Mfg. Nos.:

1695266 - 54" Mower

54" Mower Deck - Housing & Arbor Group

987553

NOTE: Unless noted otherwise,
use the standard hardware torque
specification chart.

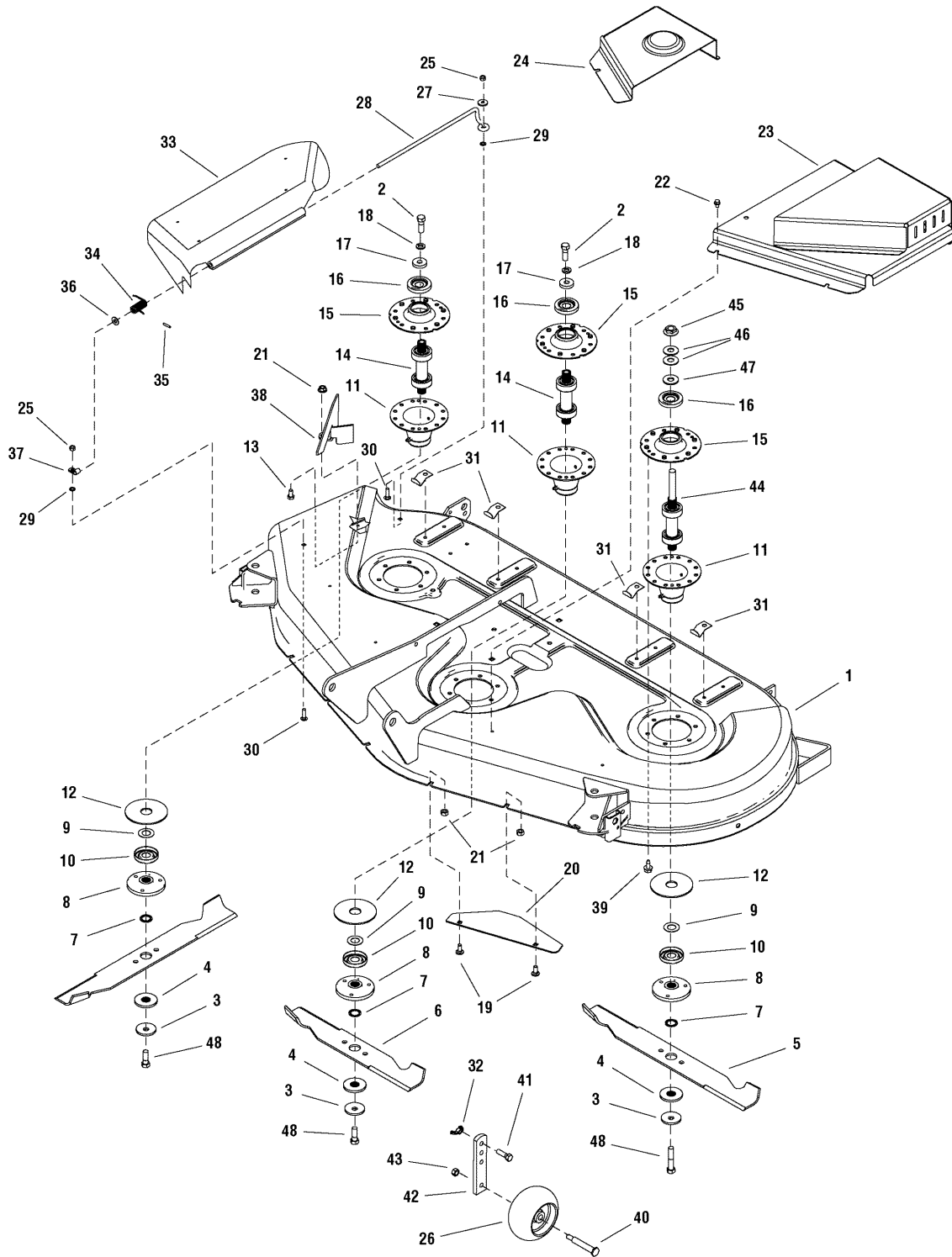

The above parts group applies to the following Mfg. Nos.:
1695266 - 54" Mower

54" Mower Deck - Housing & Arbor Group

REF NO	PART NO.	QTY.	DESCRIPTION
1	1687310SM	1	HOUSING ASSEMBLY, 54" Mower, Orange
1	1687311SM	1	HOUSING ASSEMBLY, 54" Mower, Red
2	2823471SM	5	CAPSCREW, Hex Head 7/16-14 x 1-1/4 G8
3	1656916SM	3	WASHER, Spring
4	1679711SM	3	WASHER, Splined
5	1725921SM	2	BLADE, Mower 20.56
6	1725922SM	1	BLADE, Mower 16.00
7	1657528SM	3	RETAINING RING, Self Locking
8	1655777SM	3	ADAPTER, Blade
9	1700230SM	3	WASHER, Shim
10	1700229SM	3	SHIELD, Bearing
11	1703273ASM	3	HOUSING & FITTING ASSEMBLY, Lower
12	1707335SM	3	GASKET, Foam
13	1925205SM	1	CAPSCREW, Hex Head 5/16-18 x 5/8 G5
14	1676278SM	2	ARBOR SHAFT & BEARINGS ASSEMBLY
15	1655729ASM	3	HOUSING, Arbor Top
16	1657969SM	3	SHIELD, Bearing, Mower Arbor, Upper
17	1933263SM	2	WASHER
18	1918199SM	2	LOCKWASHER, Spring
19	1931333SM	2	CARRIAGE BOLT, 5/16-18 x 3/4 G5
20	1720962ASM	1	BAFFLE, Front
21	1960684SM	3	NUT, Hex KEPS 5/16-18 Conical Washer
22	1929000SM	4	SCREW, Hex Washer Head Taptite 1/4-20 x 3/8
23	1720621CSM	1	COVER ASSEMBLY, Upper, Orange
23	1720621DSM	1	COVER ASSEMBLY, Upper, Red
24	1733373CSM	1	COVER, Arbor R.H. 54", Orange
24	1733373DSM	1	COVER, Arbor R.H. 54", Red
25	1920397SM	2	NUT, Hex Lock ESNA Light 1/4-20
26	1700184SM	2	WHEEL
27	1960353SM	1	WASHER, 1/4
28	1706709SM	1	ROD, Deflector, Front
29	1960518SM	2	NUT, Push
30	1960698SM	2	CARRIAGE BOLT, 1/4-20 x 1 G5
31	1720623SM	4	CLIP, Spring
32	7091049SM	2	NUT, Wing 3/8-16
33	1705449SM	1	DEFLECTOR
34	7101082SM	1	SPRING, Torsion, Chute
35	1723323SM	1	CAP
36	1919326SM	1	WASHER, 5/16
37	1704873SM	1	CLAMP, Wire
38	1724976ASM	1	BAFFLE, Discharge
39	1664847SM	18	SCREW, Hex Washer Head Taptite 5/16-18 x 3/4
40	7029265SM	2	BOLT, Shoulder, 3/8-16
41	1920415SM	2	CAPSCREW, Hex Head 3/8-16 x 1-1/4 G5
42	7035835SM	2	POST, Anti-Scalp

Footnotes

The above parts group applies to the following Mfg. Nos.:

1695266 - 54" Mower

54" Mower Deck - Housing & Arbor Group

987553

NOTE: Unless noted otherwise,
use the standard hardware torque
specification chart.

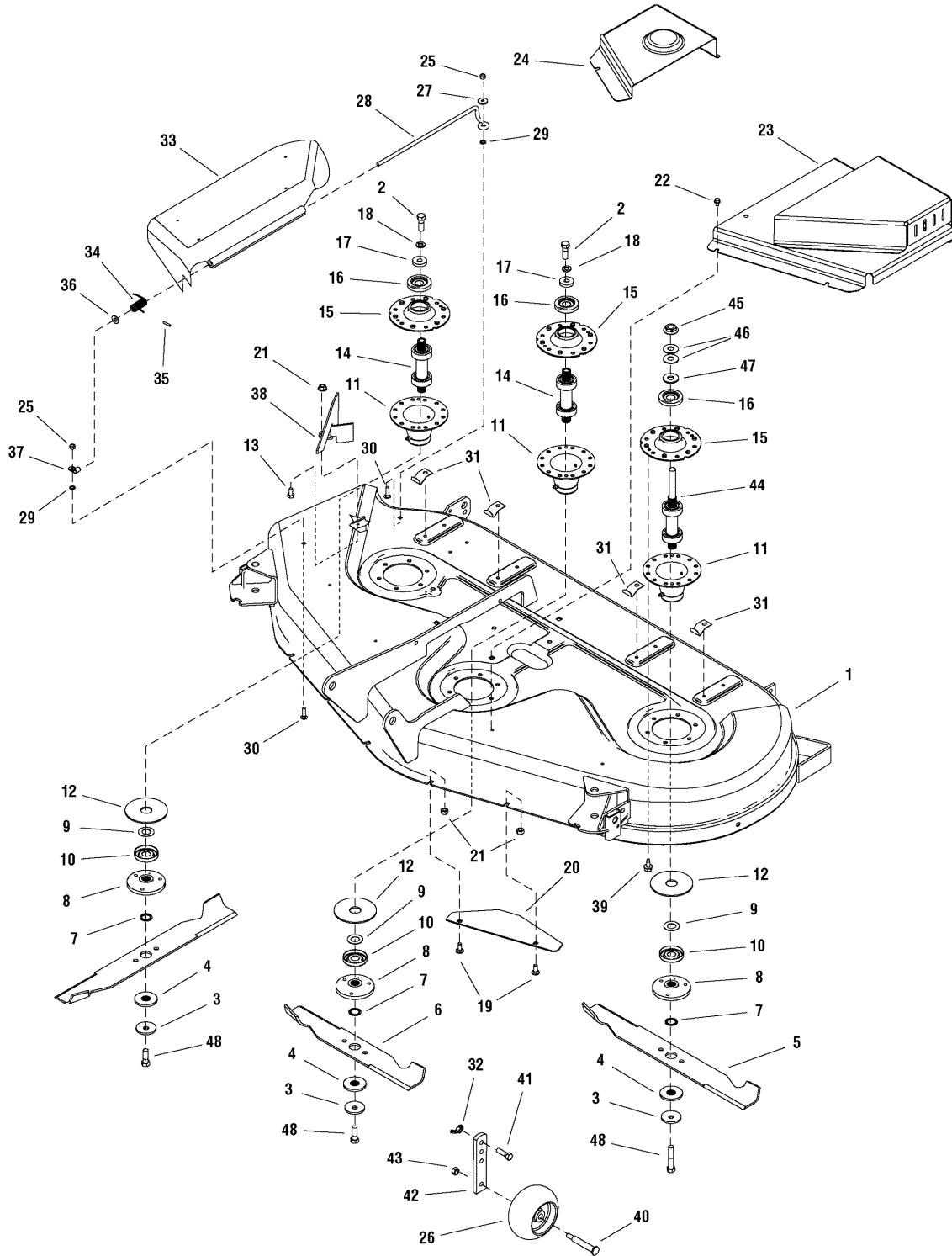

The above parts group applies to the following Mfg. Nos.:
1695266 - 54" Mower

54" Mower Deck - Housing & Arbor Group

REF NO	PART NO.	QTY.	DESCRIPTION
44	1726825SM	1	ARBOR SHAFT & BEARINGS ASSEMBLY, 40"
45	1714419SM	1	NUT, Hex Flange 9/16-18
46	1713675SM	2	WASHER, Bellville
47	1918431SM	1	WASHER, 1/2
48	2827120SM	1	CAPSCREW, Hex Head 7/16-14 x 2-1/4 G8

Footnotes

The above parts group applies to the following Mfg. Nos.:

1695266 - 54" Mower

Hardware Identification & Torque Specifications

Common Hardware Types

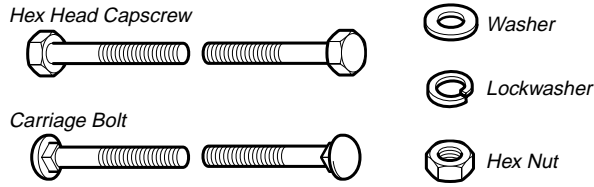

Standard Hardware Sizing

When a washer or nut is identified as 1/2", this is the *Nominal size*, meaning the *inside diameter* is 1/2 inch; if a second number is present it represents the *threads per inch*

When bolt or capscrew is identified as 1/2 - 16 x 2", this means the *Nominal size*, or *body diameter* is 1/2 inch; the second number represents the *threads per inch* (16 in this example, and the final number is the *body length* of the bolt or screw (in this example 2 inches long).

The guides and ruler furnished below are designed to help you select the appropriate hardware and tools.

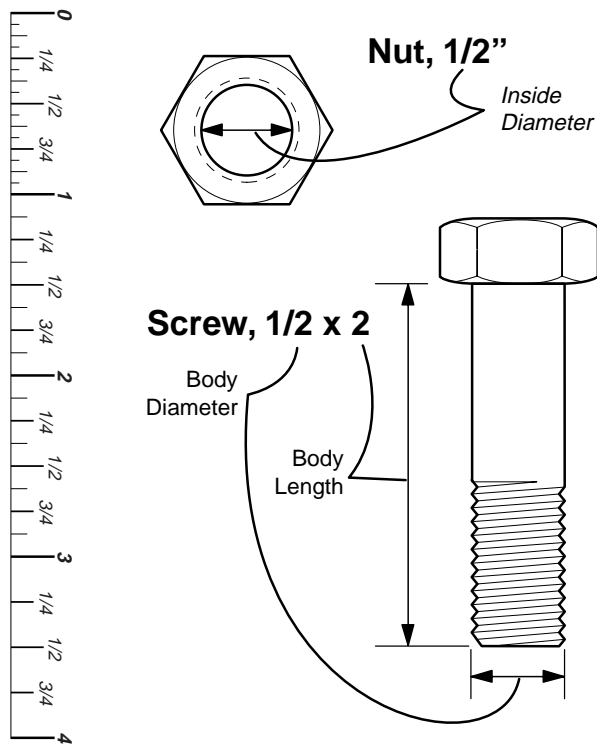

Torque Specification Chart						
FOR STANDARD MACHINE HARDWARE (Tolerance ± 20%)						
Hardware Grade	No Marks SAE Grade 2		SAE Grade 5		SAE Grade 8	
	in/lbs ft/lbs	Nm.	in/lbs ft/lbs	Nm.	in/lbs ft/lbs	Nm.
8-32	19	2.1	30	3.4	41	4.6
8-36	20	2.3	31	3.5	43	4.9
10-24	27	3.1	43	4.9	60	6.8
10-32	31	3.5	49	5.5	68	7.7
1/4-20	66	7.6	8	10.9	12	16.3
1/4-28	76	8.6	10	13.6	14	19.0
5/16-18	11	15.0	17	23.1	25	34.0
5/16-24	12	16.3	19	25.8	27	34.0
3/8-16	20	27.2	30	40.8	45	61.2
3/8-24	23	31.3	35	47.6	50	68.0
7/16-14	30	40.8	50	68.0	70	95.2
7/16-20	35	47.6	55	74.8	80	108.8
1/2-13	50	68.0	75	102.0	110	149.6
1/2-20	55	74.8	90	122.4	120	163.2
9/16-12	65	88.4	110	149.6	150	204.0
9/16-18	75	102.0	120	163.2	170	231.2
5/8-11	90	122.4	150	204.0	220	299.2
5/8-18	100	136	180	244.8	240	326.4
3/4-10	160	217.6	260	353.6	386	525.0
3/4-16	180	244.8	300	408.0	420	571.2
7/8-9	140	190.4	400	544.0	600	816.0
7/8-14	155	210.8	440	598.4	660	897.6
1-8	220	299.2	580	788.8	900	1,244.0
1-12	240	326.4	640	870.4	1,000	1,360.0

NOTES

- These torque values are to be used for all hardware excluding: locknuts, self-tapping screws, thread forming screws, sheet metal screws and socket head setscrews.
- Recommended seating torque values for locknuts:
 - for prevailing torque locknuts - use 65% of grade 5 torques.
 - for flange whizlock nuts and screws - use 135% of grade 5 torques.
- Unless otherwise noted on assembly drawings, all torque values must meet this specification.

Wrench & Fastener Size Guide



1/4" Bolt or Nut
Wrench—7/16"

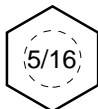

5/16" Bolt or Nut
Wrench—1/2"

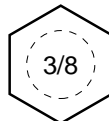

3/8" Bolt or Nut
Wrench—9/16"



7/16" Bolt or Nut
Wrench (Bolt)—5/8"
Wrench (Nut)—11/16"

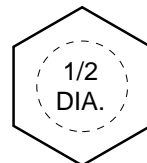

1/2" Bolt or Nut
Wrench—3/4"

Simplicity

MANUFACTURING, INC.
500 N. Spring Street / PO Box 997
Port Washington, WI 53074-0997 USA

www.simplicitymfg.com

Briggs and Stratton Yard Power Products Group
Copyright © 2008 by Briggs and Stratton Corporation
Milwaukee, WI, USA. All rights reserved

