

Safety Instructions & Operator's Manual for **SNAPPER**[®]

21" STEEL DECK WALK MOWERS SERIES 12 ELECTRIC START

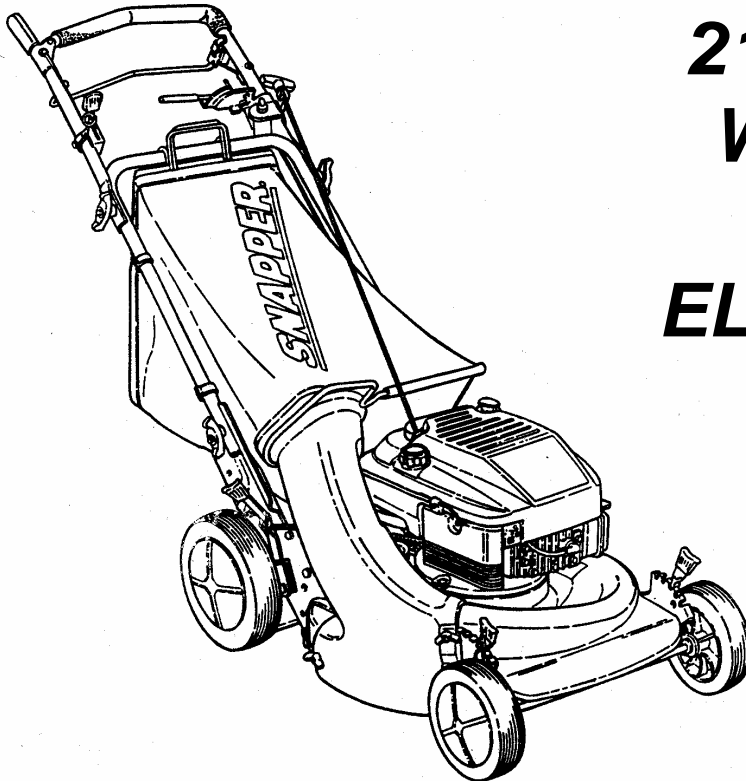

MODELS
PROPELLED MODELS
P216012E
FRP216012E
NFRP216012E

MODEL NUMBER EXPLANATION

N	F	R	P	21	60	12	E
---	---	---	---	----	----	----	---

MODEL DESIGNATION
SELF-PROPELLED
CUTTING WIDTH

ENGINE OPTIONS
SERIES DESIGNATION
ENGINE HORSE POWER

N - California Model	F - Flange Deck
R - Recycling Mower	P - Self-Propelled Mower
21 - 21" Cutting Width	
60 - 6.0 HP (Engine Horse Power)	
12 - Series Designation	
E - Electric Start	

Thank you for buying a SNAPPER Product! Before operating your Walk Behind, read this manual carefully and pay particular attention to the "IMPORTANT SAFETY INSTRUCTIONS" on Pages 2 & 3. Remember that all power equipment can be dangerous if used improperly. Also keep in mind that SAFETY requires careful use in accordance with the operating instructions and common sense.

SNAPPER[®] McDonough, GA., 30253 U.S.A.



IMPORTANT SAFETY INSTRUCTIONS



WARNING: This powerful cutting machine is capable of amputating hands and feet and can throw objects that can cause injury and damage! Failure to comply with the following SAFETY instructions could result in serious injury or death to the operator or other persons. The owner of the machine must understand these instructions and must allow only persons who understand these instructions to operate machine. Each person operating the machine must be of sound mind and body and must not be under the influence of any substance, which might impair vision, dexterity or judgment. If you have any questions pertaining to your machine which your dealer cannot answer to your satisfaction, call or write the Customer Service Department at SNAPPER, McDonough, Georgia 30253. Phone: (1-800-935-2967).

PROTECTION FOR CHILDREN

Tragic accidents can occur if the operator is not alert to the presence of children. Children are often attracted to the machine and the mowing activity. Never assume that children will remain where you last saw them.

1. **KEEP** children out of the mowing area and under the watchful care of a responsible adult.
2. **DO NOT** allow children in yard when machine is operated and turn machine **OFF** if anyone enters the area.
3. **DO NOT** allow pre-teenage children to operate machine.
4. **ALLOW** only responsible adults & teenagers with mature judgment under close adult supervision to operate machine.
5. **DO NOT** pull mower backwards unless absolutely necessary. **LOOK** and **SEE** behind and down for children, pets and hazards before and while backing.
6. **USE EXTRA CARE** when approaching blind corners, shrubs, trees, or other objects that may obscure vision.

SLOPE OPERATION

1. Slopes are a major factor related to slip and fall accidents, which can result in severe injury. All slopes require extra caution. If you feel uneasy on a slope, **DO NOT** mow it.
2. Mow across slopes, never up-and-down. Exercise extreme **CAUTION** when changing directions on slopes. **DO NOT** mow steep slopes or other areas where stability or traction is in doubt.
3. Use extra care with grass catchers or other attachments; these affect the handling and the stability of the machine.

PREPARATION

1. Read, understand, and follow instructions and warnings in this manual and on the mower, engine and attachments. Know the controls and the proper use of the mower before starting.
2. Only mature, responsible persons shall operate the machine and only after proper instruction.

PREPARATION

(Continued From Previous Column)

3. Data indicates that operators age 60 and above, are involved in a large percentage of mower-related injuries. These operators should evaluate their ability to operate the mower safely enough to protect themselves and others from serious injury.
4. Handle fuel with extra care. Fuels are flammable and vapors are explosive. Use only an approved fuel container. **DO NOT** remove fuel cap or add fuel with engine running. Add fuel outdoors only with engine stopped and cool. Clean spilled fuel and oil from machine. **DO NOT** smoke.
5. Check the area to be mowed and remove all objects such as toys, wire, rocks, limbs and other objects that could cause injury if thrown by blade or interfere with mowing. Also note the location of holes, stumps, and other possible hazards.
6. Keep people and pets out of the mowing area. Immediately, **STOP** Blade, Stop engine and Stop mower if anyone enters the area.
7. Check shields, deflectors, switches, blade controls and other safety devices frequently for proper operation and location.
8. Make sure all safety decals are clearly legible. Replace if damaged.
9. Protect yourself when mowing and wear safety glasses, long pants and substantial footwear. **DO NOT** mow barefooted or with sandals.
10. Know how to **STOP** blade and engine quickly in preparation for emergencies.
11. Use extra care when loading or unloading the machine into a trailer or truck.
12. Check grass catcher components frequently for signs of wear or deterioration and replace as needed to prevent injury from thrown objects going through weak or torn spots.



IMPORTANT SAFETY INSTRUCTIONS



OPERATION

1. **DO NOT** put hands or feet near or under rotating parts. Keep clear of discharge area while engine is running.
2. **STOP** engine when crossing gravel drives, walks, or roads, and under any conditions where thrown objects might be a hazard.
3. Mow only in daylight or good artificial light.
4. **DO NOT** operate mower while under the influence of alcohol or drugs.
5. After striking a foreign object or if mower vibrates abnormally, **STOP** the engine, disconnect and secure spark plug wire. Inspect the mower for any damage and repair the damage.
6. **DO NOT** mow near drop offs, ditches or embankments. Operator could lose footing or balance.
7. **STAY ALERT** for holes and other hidden hazards. Tall grass can hide obstacles. Keep away from ditches, washouts, culverts, fences and protruding objects.
8. **DO NOT** mow on wet grass. Always be sure of your footing. Keep a firm hold on the handle and walk, never run. Slipping could cause injury.
9. **DO NOT** leave the machine with the engine running. **STOP BLADE** and **STOP ENGINE** before leaving the operators position for any reason.
10. Before cleaning, repairing or inspecting make certain engine, blade and all moving parts have **STOPPED**. Disconnect and secure spark plug wire away from plug to prevent accidental starting.
11. **STOP** engine and wait until the blade comes to complete **STOP** before removing grass bag and/or clearing grass.
12. **DO NOT** operate mower without the entire grass catcher or guards in place. **DO NOT** point discharge at people, passing cars, windows or doors.
13. Slow down before turning.
14. Watch out for traffic when near or crossing roadways.
15. **DO NOT** operate engine in enclosed areas. Engine exhaust gases contain carbon monoxide, a deadly poison.

MAINTENANCE AND STORAGE

1. **DO NOT** store mower or fuel container inside where fumes may reach an open flame, spark or pilot light such as in a water heater, furnace, clothes dryer or other gas appliance. Allow engine to cool before storing machine in an enclosure. Store fuel container out of reach of children in a well ventilated, unoccupied building.
2. Keep mower and engine free of grass, leaves or excess grease to reduce fire hazard and engine overheating.
3. When draining fuel tank, drain fuel into an approved container outdoors and away from open flame.
4. Keep all bolts, especially blade bolts, nuts and screws properly tight. Check that all cotter pins are in proper position.
5. Always provide adequate ventilation when running engine. Engine exhaust gases contain carbon monoxide, a deadly poison.
6. Service engine and make adjustments only when engine is stopped. Removed spark plug wire from spark plug and secure wire away from spark plug to prevent accidental starting.
7. **DO NOT** change engine governor speed settings or overspeed engine.
8. Check grass bag assembly frequently for wear or deterioration to avoid thrown objects and exposure to moving parts. Replace with new bag if loose seams or tears are evident. Replace slider or bag adapter if broken or cracked.
9. Mower blades are sharp and can cut. Wrap the blades or wear heavy leather gloves and use **CAUTION** when handling them.
10. **DO NOT** test for spark by grounding spark plug next to spark plug hole; spark plug could ignite gas exiting engine.
11. Have machine serviced by an authorized **SNAPPER** dealer at least once a year and have the dealer install any new safety devices.
12. Use only genuine **SNAPPER** replacement parts to assure that original standards are maintained.

TABLE OF CONTENTS

IMPORTANT SAFETY INSTRUCTIONS.....	2&3
TABLE OF CONTENTS	4
SECTION 1 - FAMILIARIZATION.....	5
SECTION 2 - OPERATING INSTRUCTIONS.....	6-9
Pre-start Checklist	6
Starting & Stopping Engine & Blade.....	6-7
Starting & Stopping Wheel Drive	7
Handle Height Adjustment.....	7
Cutting Height Adjustment	8
Recycling Operation	8
Baffle Adjustment	8
Installation of Grass Catcher	9
SECTION 3 - MAINTENANCE INSTRUCTIONS.....	10-11
Change Engine Oil.....	10
Check Transmission Grease.....	10-11
Check Mower Blade.....	11
Check Engine Drive Belt	11
Check Transmission Poly-V Belt.....	11
Service - Annually	11
Engine.....	11
Air Filter	11
Engine Oil.....	11
Storage Procedure.....	11
SECTION 4 - ADJUSTMENTS AND REPAIR	12-20
Mower Blade Replacement	12
Blade Sharpening	12-13
Wheel Drive Control Adjustment.....	13
Driven and Drive Disc Service.....	13
Cleaning Drive Disc and Driven Disc.....	14
Drive Spring Repair/Replacement.....	14
Driven Disc Adjustment	14-15
Driven Disc Replacement.....	15-16
Driven Disc Bearing Replacement	16
Hex Shaft Bearing Replacement	17
Belt Service	17
Engine Drive Belt Replacement	17-18
Transmission Poly-V Belt Replacement.....	18
Battery Service.....	19-20
TROUBLESHOOTING	21
SERVICE SCHEDULE	22
WARRANTY	23
PRIMARY MAINTENANCE	24-27

Section 1 - FAMILIARIZATION

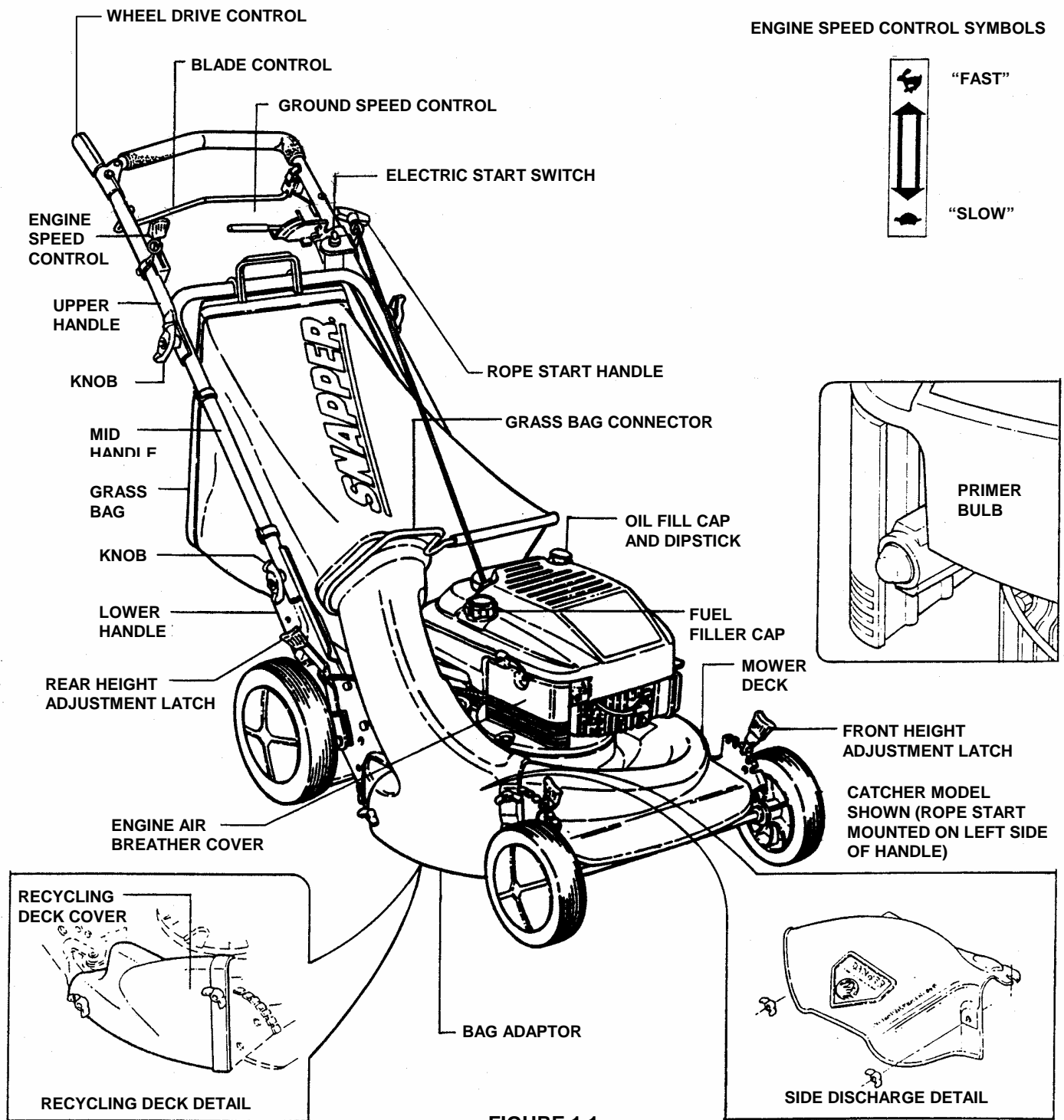

FIGURE 1.1

1.1 INTRODUCTION

This manual has been prepared for the operators of the SNAPPER WALK BEHIND MOWERS. Its purpose, aside from recommending operating and routine service requirements, is to promote safety through the use of accepted operating practices. **Read, Understand and Follow** the "IMPORTANT SAFETY INSTRUCTIONS" on Pages 2 & 3 of this manual and all safety messages on the mower and attachments before operating the mower.

1.2 NOMENCLATURE

The nomenclature drawing above, Figure 1.1, shows the essential parts of the SNAPPER WALK BEHIND MOWERS. It is recommended that all operators of the mower become thoroughly familiar with the controls, parts and operation of the mower before operating. Specific details involving the engine are found in the separate engine owner's manual. Study these manuals before operating and keep both handy for future reference.

Section 2 - OPERATING INSTRUCTIONS

2.1 PRE-START CHECK LIST

Make the following checks and perform the service required before each start-up.

2.1.1. Check guards, deflectors, grass bag, adapter and covers to make sure all are in place and securely tightened.

2.1.2. Check blade control and wheel drive control to insure they work freely. See Figure 2.1.

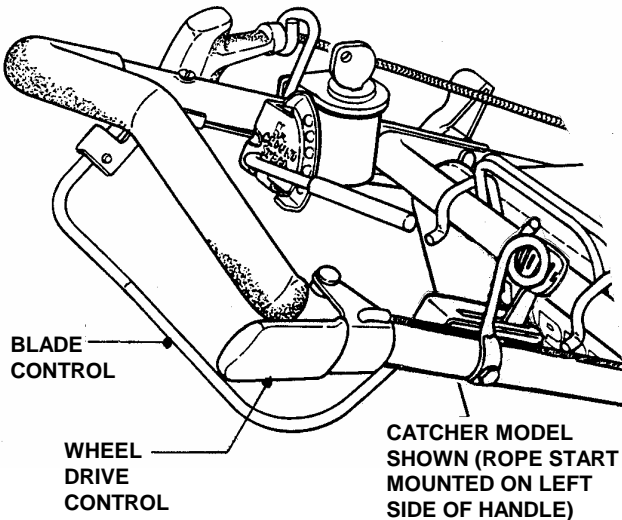

FIGURE 2.1

2.1.3. Check cutting height. Adjust to desired height.

2.1.4. Check engine oil and add oil as needed to bring level up to the full mark. Refer to Engine Owner's Manual for oil specifications. See Figure 2.2.

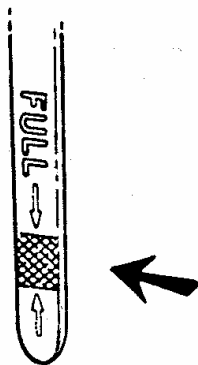

FIGURE 2.2

2.1.5. The battery should be removed from its carton and filled with electrolyte. See Section on Battery Service for battery preparation.

2.1.6. Add fuel to tank after pushing the mower outside where fumes can safely dissipate. Make sure cap is tightened after refueling. Refer to Engine Owners Manual for specifications.

2.1.7. Clean exterior surfaces of cutting deck and engine of any accumulation of spilled fuel, dirt, grass, oil, etc. Keep engine air intake screen and cooling fins clear at all times.

2.2 STARTING & OPERATION

2.2.1. ENGINE & BLADE (Primer Models) (Electric Start)

When the ignition key (Electric Start Switch) is turned to "START", the engine will not crank and will not start unless the blade control is engaged!

1. Move engine speed control to the "Fast" (Rabbit) position. See Figure 2.3.

2. Push primer button three times to start a cold engine. **NOTE:** Do not use primer button to start warm engine.

NOTE: Stop the engine (and blade) by releasing the blade control.

3. Pull blade control against handle.

4. Turn key to the start position until engine starts. See Figure 2.3.

NOTE: If after 5 seconds of cranking the engine does not start, release the key and attempt starting again after waiting for approximately 20 seconds.

5. After engine starts, allow a brief warm-up until engine runs smooth.

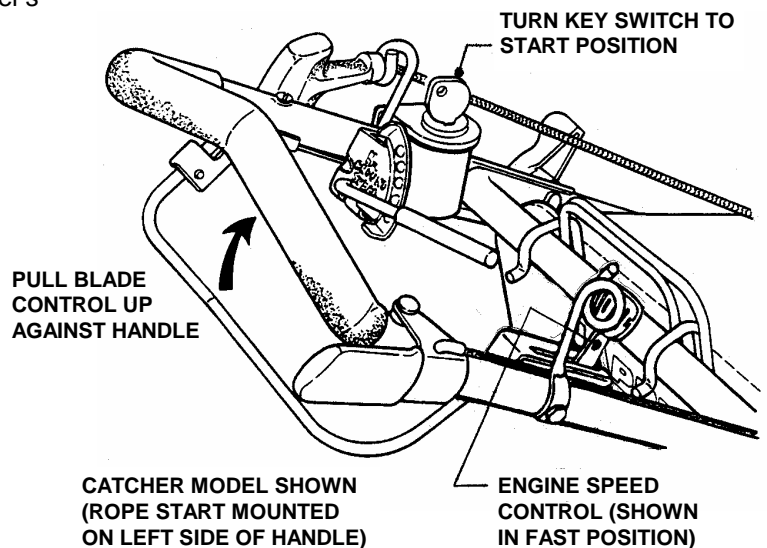

FIGURE 2.3

Section 2 - OPERATING INSTRUCTIONS

2.2 STARTING & OPERATION (Continued)

2.2.2. ENGINE & BLADE (Primer Models) (Recoil Start)

If the battery is dead or too weak to crank engine use the recoil backup. When using the recoil to start the engine, leave the key switch in the "RUN" position and pull the blade control up against the handle before pulling the rope.

1. Move engine speed control to the "Fast" (Rabbit) position. See Figure 2.4.
2. Push primer button three times to start a cold engine. **NOTE:** Do not use primer button to start warm engine.

NOTE: Stop the engine (and blade) by releasing the blade control.

3. Pull blade control against handle.
4. Pull rope start handle until engine starts. See Figure 2.4.
5. After engine starts, allow a brief warm-up until engine runs smooth.

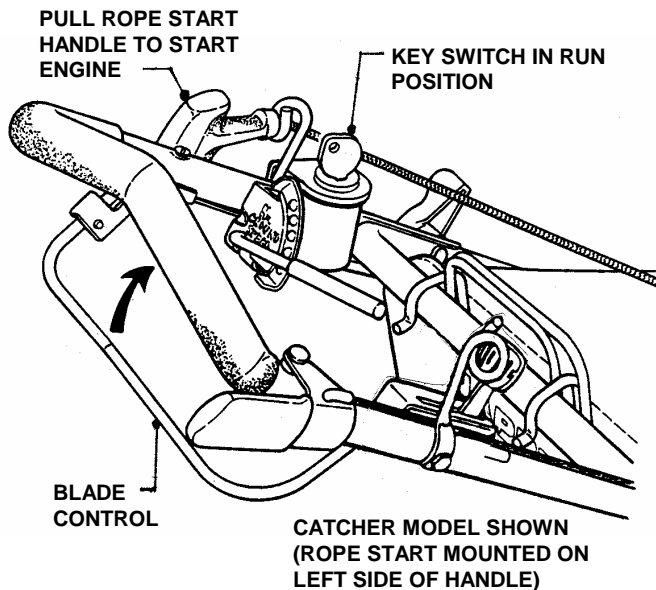

FIGURE 2.4

2.2.3. PROPELLING MOWER (Self Propelled Models)

1. Move ground speed control to the desired speed position. See Figure 2.5.
2. Move wheel drive control against handle to engage wheel drive and propel mower forward. Forward speed can be adjusted while the mower is moving by changing position of the ground speed control. See Figure 2.5.

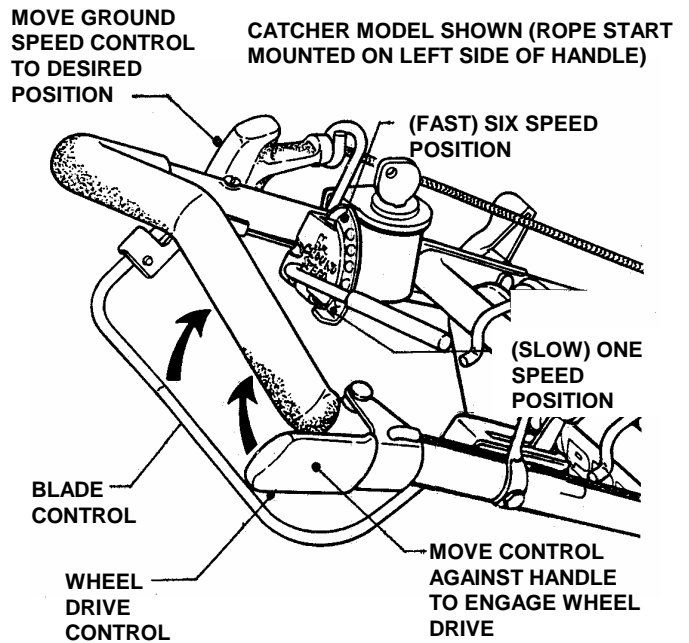

FIGURE 2.5

2.3 STOPPING

1. Stop engine and blade by releasing the blade control. Stop forward motion by releasing the wheel drive control.

WARNING

STOP engine and mower blade by releasing the blade control before adjusting cutting height or handle height.

2.4 HANDLE HEIGHT ADJUSTMENT

The height of the mower handle can be adjusted as follows:

1. Loosen the lower nuts on each lower handle as shown in Figure 2.6.

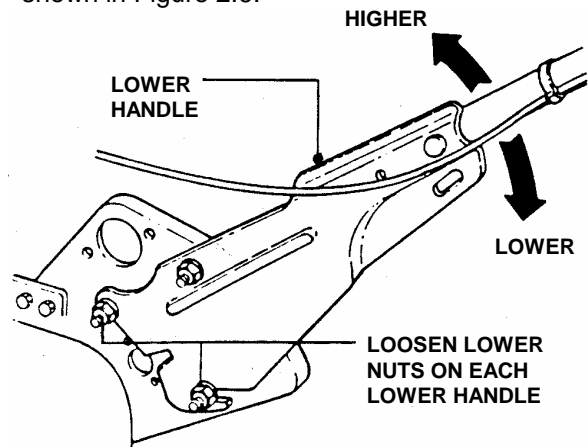

FIGURE 2.6

2. Move upper mower handle up or down until the desired position is achieved.
3. Tighten the lower nuts on each lower handle to maintain desired position.

Section 2 - OPERATING INSTRUCTIONS

WARNING

DO NOT attempt any maintenance, adjustments or service with engine and blade running. **STOP** engine and blade. Disconnect spark plug wire and secure away from spark plug. Engine and components are **HOT**. Avoid serious burns, allow sufficient time for all components to cool.

2.5 CUTTING HEIGHT ADJUSTMENT

1. Pull the height adjusting latch outward and move to desired cutting height. See Figure 2.7.

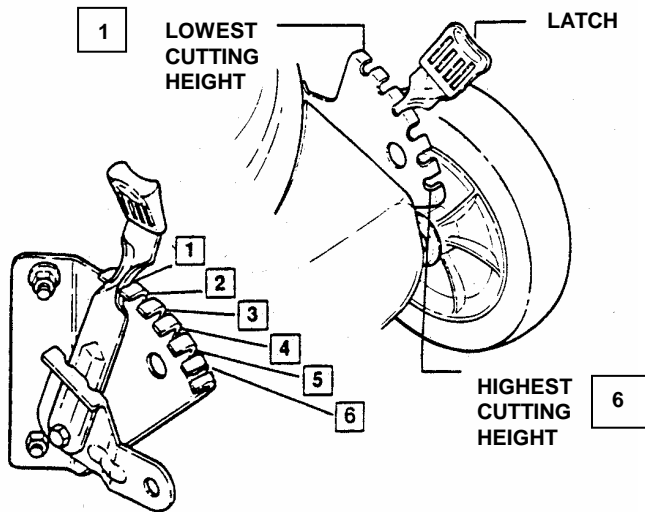
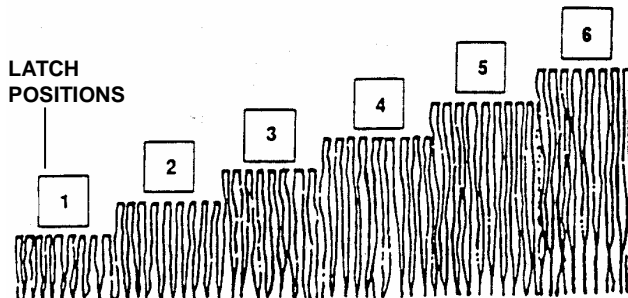

FIGURE 2.7

2. Set all wheels at the same cutting height. The highest cutting position is Notch 6. The lowest cutting position is Notch 1. See Figure 2.8.



CUTTING HEIGHT SETTINGS

FIGURE 2.8

2.6 RECYCLING OPERATION

NOTE: For best recycling results, cut up to a maximum of 1/3 of grass blade length and recycle **ONLY** when grass is dry.

1. Set all wheels in the highest cutting position (Notch 6).

2. Move engine speed control to "FAST" (Rabbit) position.
3. Move ground speed control to slowest speed setting.
4. Proceed mowing slowly. If grass is very dense, lower each rear wheel latch one notch lower than the front wheel latches to improve recycling performance.

2.7 ADJUSTING FRONT DECK BAFFLE (Models with an "F" prefix in model number) (Example: FRP216012)

The front of the cutting deck on these models has been cut out. This allows the blade to have more direct contact with the grass and allows more air flow into deck chamber. The adjustable baffle should be secured in the lowest position when using a grass bag. The baffle should be secured in the highest position when mulching grass. **NOTE:** Under certain conditions, when mulching, some grass may blow out from under front of baffle. This is normal but, the amount of grass blowing out can be reduced. Lower baffle down slightly until the smallest amount of grass blow out is present.

1. Stop engine.
2. Loosen wing nuts that secure front deck baffle. See Figure 2.9.
3. Lower the adjustable baffle to the lowest position when using a grass bag. Raise the baffle to its highest position when mulching grass. Take care to keep the baffle's lower edge parallel to the bottom of the deck. See Figure 2.9.
4. Retighten wing nuts securely.

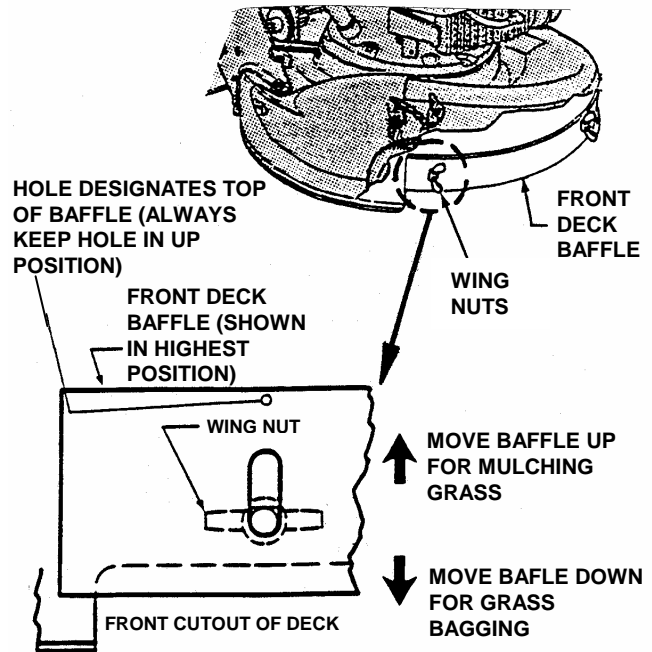

FIGURE 2.9

Section 2 - OPERATING INSTRUCTIONS

WARNING
DO NOT attempt any maintenance, adjustments or service with engine and blade running. STOP engine and blade. Disconnect spark plug wire and secure away from spark plug. Engine and components are HOT. Avoid serious burns, allow sufficient time for all components to cool.

2.8 INSTALLATION of GRASS CATCHER

Install grass catcher by sliding connector over flange of adapter. See Figure 2.10. Attach grass bag hooks over middle handle cross bar. See Figure 2.11.

POSITION BAG
BETWEEN HANDLES

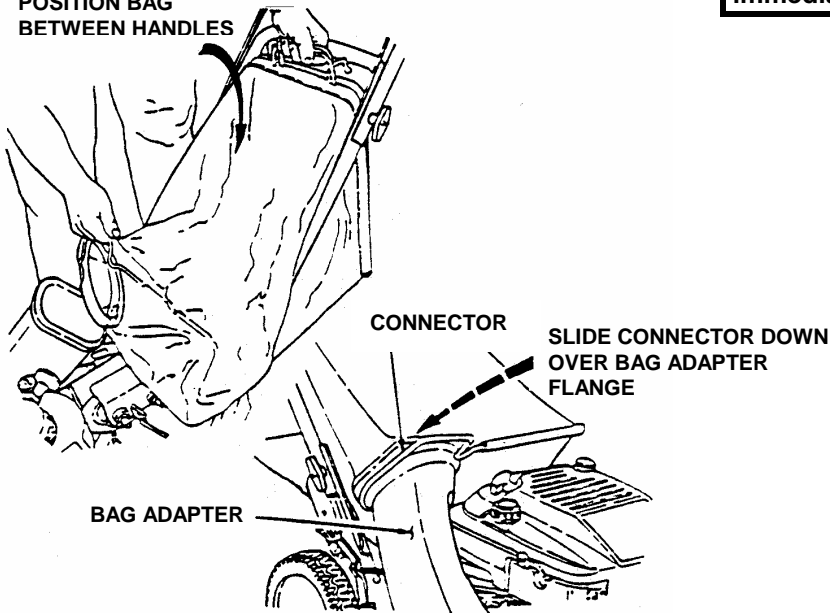

FIGURE 2.10

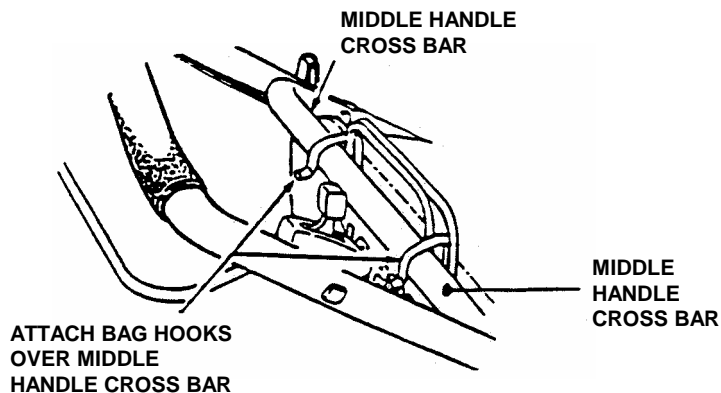

FIGURE 2.11

WARNING
DO NOT operate without entire Grass Catcher or guard in place. Grass Catcher components are subject to deterioration during normal use. Inspect frequently and replace worn or damaged components immediately.

Section 3 - MAINTENANCE

3.1 INTRODUCTION

To retain the quality of the mower, use genuine SNAPPER replacement parts only. Contact a local SNAPPER dealer for parts and service assistance. For the correct part or information for a particular mower, always mention model and serial number.

3.2 SERVICE - AFTER FIRST 5 HOURS

3.2.1. CHANGE ENGINE OIL

WARNING
DO NOT attempt any maintenance, adjustments or service with engine and blade running. STOP engine and blade. Disconnect spark plug wire and secure away from spark plug. Engine and components are HOT. Avoid serious burns, allow sufficient time for all components to cool.

1. Refer to Engine Manual for proper oil specifications and procedures.
2. For simplest/cleanest oil change, loosen lower handle wing nuts and stand mower up on lower handle as shown in Figure 3.1. Drain oil through dipstick tube into a container.

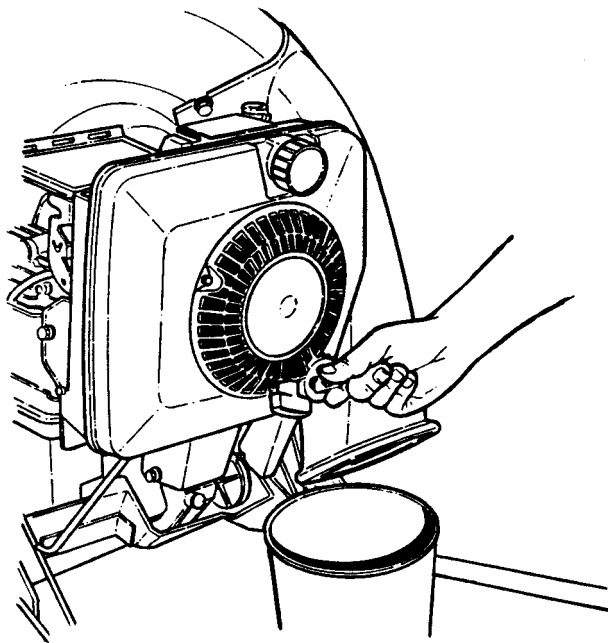

FIGURE 3.1

3.2.2. CHECK GREASE LEVEL IN TRANSMISSION

1. Remove transmission fill plug. Roll machine forward or backward while looking down into plug hole.
2. If liquid grease IS NOT visible on the input gear (the small gear below the plug hole), add an amount, to cover gear, of Snapper "00" grease. See Figure 3.2.

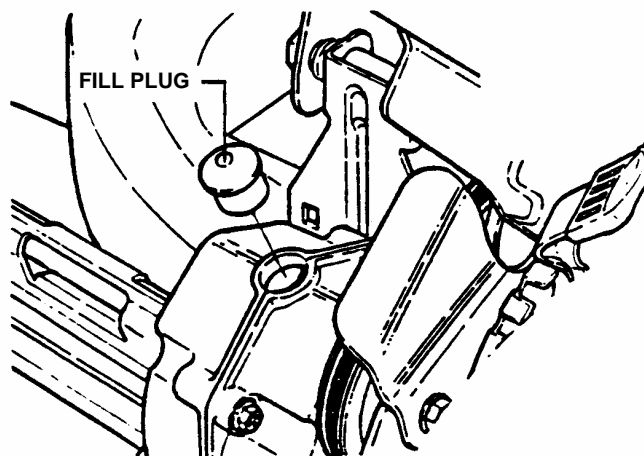

FIGURE 3.2

NOTE: Snapper "00" Grease (Part No. 2-9443) is available at your SNAPPER dealer.

(Continued on Next Page)

Section 3 - MAINTENANCE

3.2.2. CHECK GREASE LEVEL IN TRANSMISSION

NOTE: Do not spill grease or oil on surface of drive disc. See Figure 3.3.

3. Reinstall transmission plug.
4. Check grease level after each 25 hours of operation.

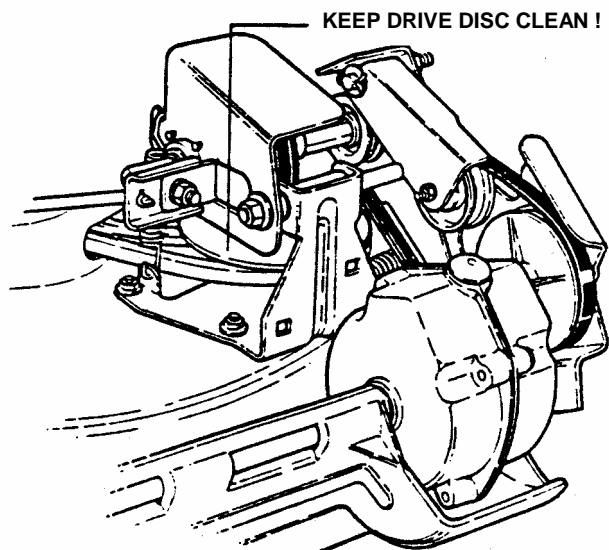

FIGURE 3.3

3.2.4 CHECK ENGINE DRIVE BELT

1. Visually check engine drive belt for cracking, fraying, severed or belt strands exposed. If worn or damaged, replace belt before operating mower.

3.2.5 CHECK TRANSMISSION POLY-V BELT

1. Visually check poly-v belt for cracking, fraying, severed or belt strands exposed. If worn or damaged, replace belt before operating mower.

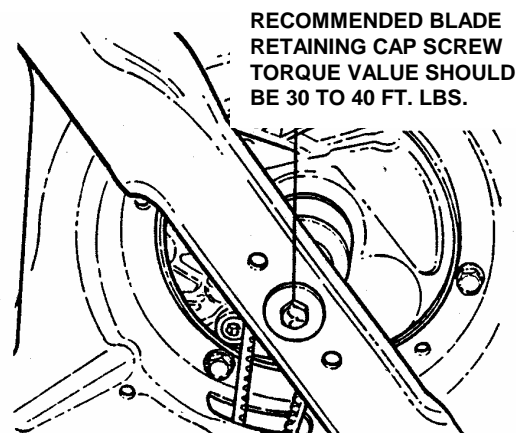

FIGURE 3.4

3.3 SERVICE - ANNUALLY

Perform all maintenance as described in the "Service Schedule" section of this manual.

3.3.1. Engine

Service engine according to engine owner's manual.

3.3.2. Air Filter

Refer to engine owner's manual for service instructions.

3.3.3. Engine Oil

Refer to engine owner's manual for service instructions.

3.4 STORAGE PROCEDURE

Refer to the Engine Owner's Manual for directions regarding engine storage preparations. Prepare the mower for "end of season" storage as follows:

1. Drain fuel from fuel tank and let engine run until all fuel is out of the carburetor.
2. **Disconnect and remove the spark plug wire away from spark plug before any other preparations are made!**
3. Tape all openings closed to prevent spraying water into exhaust or air intakes during washing.
4. Tilt mower up on its rear wheels and thoroughly clean the underside of the deck. Do not tilt mower with spark plug or carburetor down. Scrape away any accumulation of grass with a putty knife and or wire brush.
5. Lubricate all exposed metal with a light coating of oil to prevent corrosion.
6. On self-propelled models, loosen wing nuts on ground speed control rod before folding handles.
7. Loosen handle knobs. Carefully fold the handles forward, "flexing" the control cables to prevent cable damage.
8. Store the mower in a shed or other dry area, protected from weather.

WARNING

DO NOT attempt any maintenance, adjustments or service with engine and blade running. **STOP** engine and blade. Disconnect spark plug wire and secure away from spark plug. Engine and components are **HOT**. Avoid serious burns, allow sufficient time for all components to cool. Wear heavy leather gloves when handling or working around cutting blades. Blades are extremely sharp and can cause severe injury.

IMPORTANT: DO NOT tip machine with carburetor or spark plug down. Oil from crankcase will saturate the air filter and cause the engine to be hard to start or not start at all. If contamination does occur, the air filter will have to be replaced.

3.2.3 CHECK MOWER BLADE

1. Disconnect spark plug wire and secure end away from plug.
2. Tilt mower up on its rear wheels for access to the blade cap screw. Do not tilt mower with spark plug or carburetor down. See Figure 3.4.
3. Check torque of blade retaining cap screw. Recommended torque should be 30 to 40 ft. lbs. See Figure 3.4.
4. Check blade for sharpness, wear and damage. Refer to Section "Blade Wear Limits".

Section 4 - REPAIR & ADJUSTMENTS

WARNING

DO NOT attempt any maintenance, adjustments or service with engine and blade running. STOP engine and blade. Disconnect spark plug wire and secure away from spark plug. Engine and components are HOT. Avoid serious burns, allow sufficient time for all components to cool. Wear heavy leather gloves when handling or working around cutting blades. Blades are extremely sharp and can cause severe injury.

WARNING

DO NOT use a cutting blade that shows signs of excessive wear or damage. Refer to Section "MOWER BLADE REPLACEMENT" for proper blade inspection and service procedures.

4.1 MOWER BLADE REPAIR/REPLACEMENT

4.1.1. STANDARD BLADE WEAR LIMIT

1. Inspect blade frequently for signs of excessive wear or damage. See Figure 4.1.

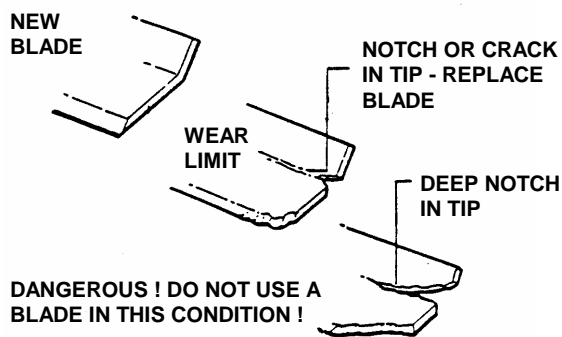

FIGURE 4.1

4.1.1A. NINJA BLADE WEAR LIMIT

1A. Inspect blade frequently for signs of excessive wear or damage. See Figure 4.2.

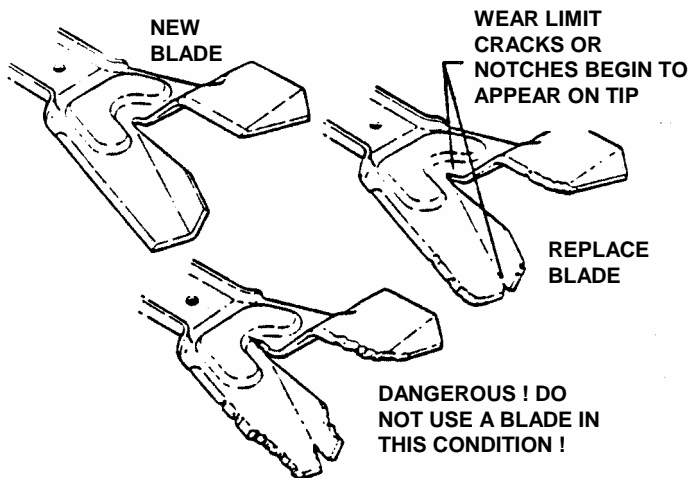

FIGURE 4.2

2. Replace the blade if it is badly chipped, bent, noticeably out of balance or has cracks or notch in either tip. See Figure 4.1. Replace with new blade.

4.1.2. BLADE SHARPENING

1. Disconnect spark plug wire and secure end away from plug.

IMPORTANT: DO NOT tip machine with carburetor or spark plug down. Oil from crankcase will saturate the air filter and cause the engine to be hard to start or not start at all. If contamination does occur, the air filter will have to be replaced.

2. Tilt mower up on its rear wheels. Do not tilt mower with spark plug or carburetor down.
3. Remove blade. See Figure 4.3.

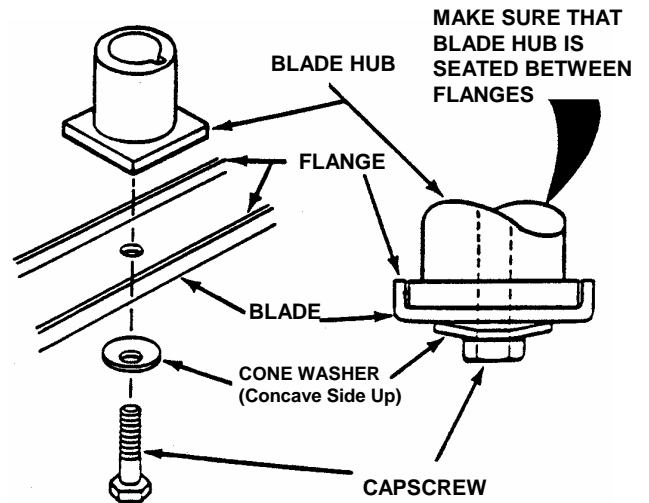

FIGURE 4.3

Section 4 - REPAIR & ADJUSTMENTS

WARNING

DO NOT attempt any maintenance, adjustments or service with engine and blade running. STOP engine and blade. Disconnect spark plug wire and secure away from spark plug. Engine and components are HOT. Avoid serious burns, allow sufficient time for all components to cool.

- Sharpen blade on a grinding wheel at an angle of 22 to 28 degrees. DO NOT sharpen blade beyond original cutting edge. See Figure 4.4.

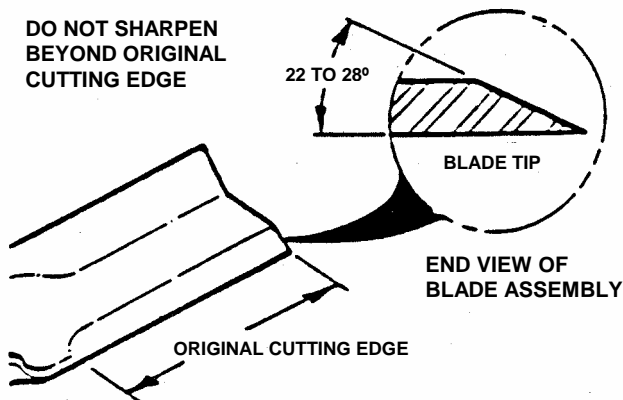

FIGURE 4.4

- Check blade for balance. If necessary, correct balance by grinding heavy end of blade.
- Reinstall blade. See Figure 4.1. Check torque of blade retaining cap screw. Recommended torque should be 30 to 40 ft. lbs.

NOTE: The following sections 4.2 through 4.4 are for self-propelled models.

4.2 WHEEL DRIVE CONTROL ADJUSTMENT

- The wheel drive control is properly adjusted when there is 1/16" to 1/8" clearance between the inside of the spring hook and the inside of the clutch cable eye with the wheel drive control released. See Figure 4.5.

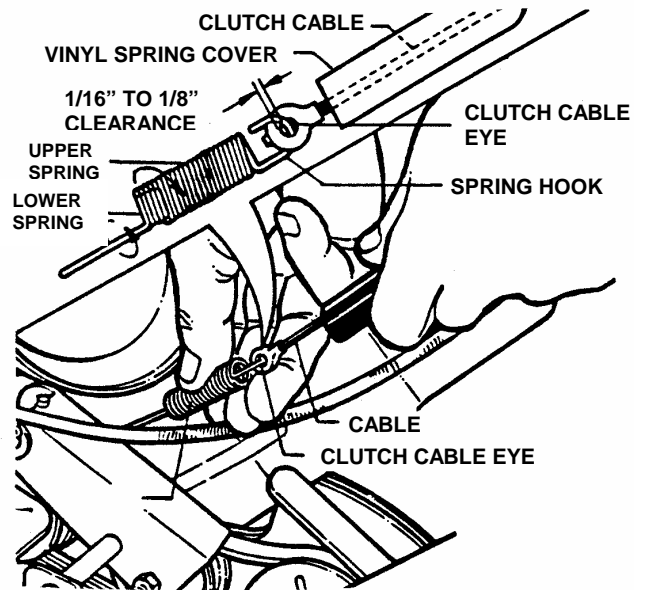

FIGURE 4.5

- To adjust, unhook upper spring from cable eye and rotate spring in direction required to extend or shorten spring length.
- Rehook upper spring to cable eye and check clearance. Repeat procedure if required.

NOTE: The vinyl spring cover should be kept over the spring at all times except for adjustments.

- If the wheel drive control fails to return quickly to the "OFF" position when released, check for binding at the cable holdings located on the side of the right handle. The upper clip should be located 2" below the upper knob; the lower clip should be 4" above the lower knob. The cable should slide freely with the clips installed at these locations.

Section 4 - REPAIR & ADJUSTMENTS

WARNING

DO NOT attempt any maintenance, adjustments or service with engine and blade running. STOP engine and blade. Disconnect spark plug wire and secure away from spark plug. Engine and components are HOT. Avoid serious burns, allow sufficient time for all components to cool.

4.3 DRIVEN DISC SERVICE

If the mower does not propel itself properly, See Figure 4.6. Check for the following problems:

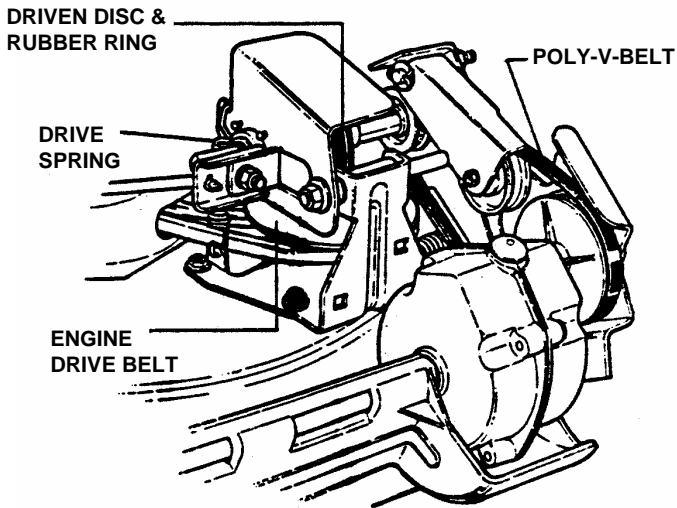

FIGURE 4.6

1. Grease on drive disc causing slippage.
2. Broken or disconnected drive spring.
3. Driven disc is out of adjustment.
4. Driven disc rubber ring is worn - does not contact drive disc properly.
5. Worn Poly-V Belt or engine drive belt.

NOTE: If any of the above (1 thru 5) are causing problems, service as follows:

4.3.1. Cleaning Drive Disc & Driven Disc.

If oil or grease on the drive disc or driven disc is causing slippage, clean discs as follows:

1. Wipe away any oil or grease with a clean cloth.
2. Use either an approved grease solvent or hot, soapy water to clean drive disc or driven disc.
3. Rinse components with clean water.
4. Dry components with a clean cloth.

4.3.2. Drive Spring Repair/Replacement

If drive spring is loose, reconnect as shown in Figure 4.7. If spring is broken, replace with new spring.

IMPORTANT: If machine drive system continues slipping see Trouble Shooting section.

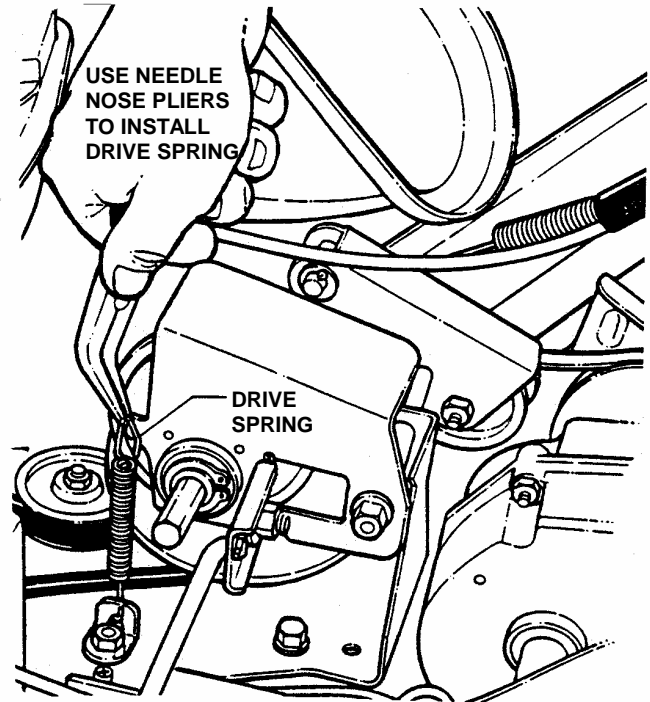

FIGURE 4.7

4.3.3. DRIVEN DISC ADJUSTMENT

If the drive disc and driven disc are clean and the mower drive is still slipping, adjust the driven disc as follows:

1. Place shift rod in the sixth speed position. See Figure 4.8.

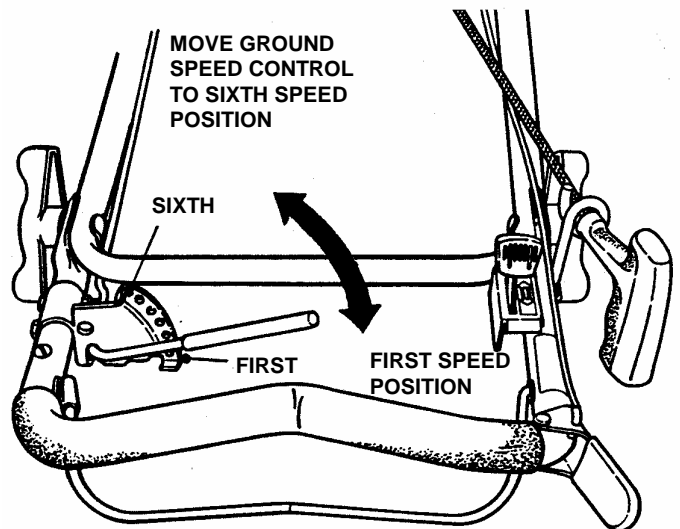

FIGURE 4.8

Section 4 - REPAIR & ADJUSTMENTS

WARNING

DO NOT attempt any maintenance, adjustments or service with engine and blade running. STOP engine and blade. Disconnect spark plug wire and secure away from spark plug. Engine and components are HOT. Avoid serious burns, allow sufficient time for all components to cool.

4.3.3. DRIVEN DISC ADJUSTMENT (Continued From Previous Page)

2. Remove driven disc spring from driven disc assembly. Loosen connector hex nut. See Figure 4.9.

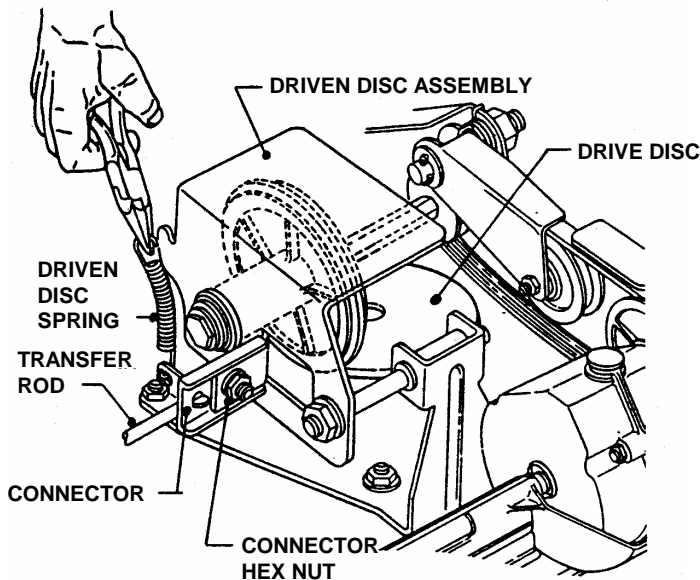

FIGURE 4.9

3. Slide driven disc assembly over to 1/8" from outside edge of drive disc. Maintaining the 1/8" measurement, remove any looseness from the linkage. This can be done by holding the transfer rod and applying pressure to the left (as viewed from operators position). Then retighten the connector hex nut securely. See Figure 4.10. Move ground speed control to the first speed position, then back to the sixth speed position. Recheck the 1/8" measurement described previously. Reinstall driven disc spring to driven disc assembly.

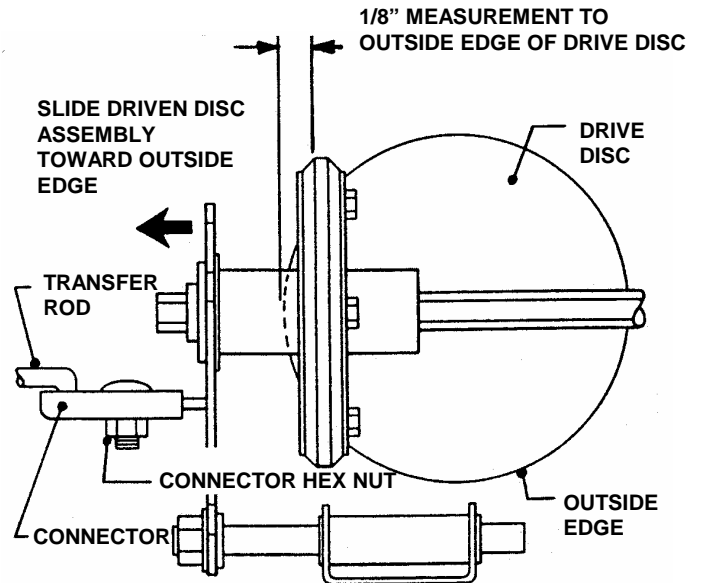

FIGURE 4.10

4.3.4. Replacing Driven Disc Rubber Ring

If the rubber ring is badly chunked or worn down to within 1/16" of the metal rim of the driven disc hub, it must be replaced. Install new rubber ring as follows:

1. Using a small flat blade screwdriver, free the clip from the transfer rod. Then remove the transfer rod from the clip and the speed control rod. See Figure 4.11.

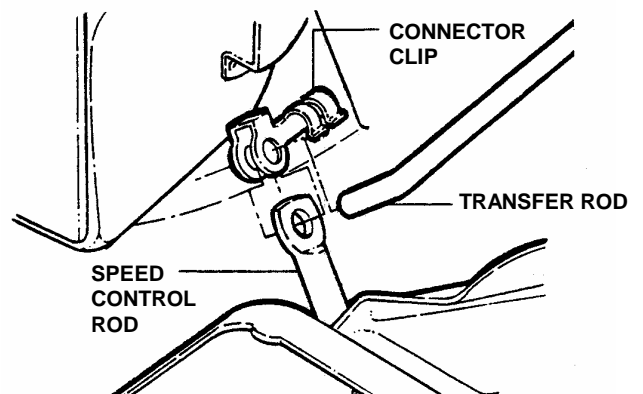

FIGURE 4.11

Section 4 - REPAIR & ADJUSTMENTS

⚠ WARNING ⚠

DO NOT attempt any maintenance, adjustments or service with engine and blade running. **STOP** engine and blade. Disconnect spark plug wire and secure away from spark plug. Engine and components are **HOT**. Avoid serious burns, allow sufficient time for all components to cool.

4.3.4. Replacing Driven Disc Rubber Ring (Continued From Previous Page)

2. Using needle nose pliers, unhook the drive spring and slide the driven disc assembly off the hex shaft. See Figure 4.12.
3. Remove the five machine screws and plate which secure the rubber ring to the driven disc hub. See Figure 4.13.
4. Install new rubber ring.
5. Reverse above procedures for reassembly and installation.

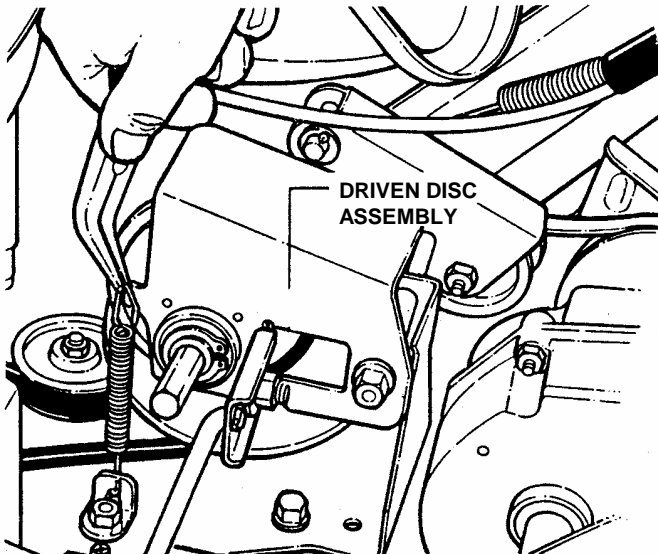

FIGURE 4.12

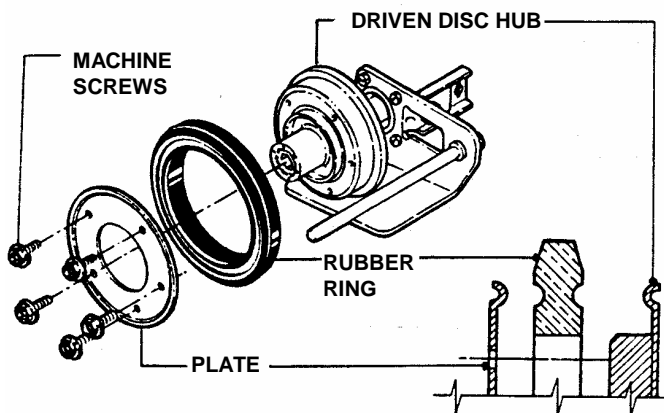

FIGURE 4.13

4.3.5. Replacing Bearing In Driven Disc Assembly

If the driven disc bearing fails, remove the driven disc assembly and replace bearing as follows:

1. Remove snap ring. See Figure 4.14.

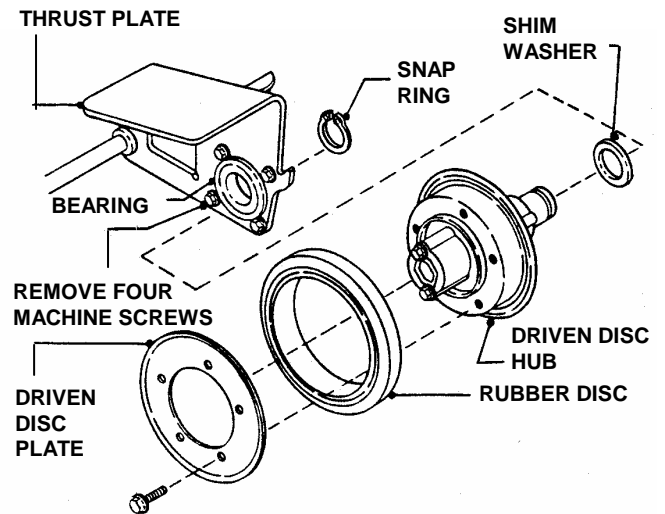

FIGURE 4.14

2. Slide the hub assembly out of the bearing.
3. Remove the four screws.
4. Remove bearing and replace with new bearing.
5. Reassemble components in reverse order.

Section 4 - REPAIR & ADJUSTMENTS

WARNING

DO NOT attempt any maintenance, adjustments or service with engine and blade running. STOP engine and blade. Disconnect spark plug wire and secure away from spark plug. Engine and components are HOT. Avoid serious burns, allow sufficient time for all components to cool.

4.3.6. Replacement Of Bearing On Pulley End Of Hex Shaft

To replace the bearing on the pulley end of the hex shaft, proceed as follows:

1. Hold the hex shaft with an adjustable wrench held next to the pulley.
2. Remove the 3/8" hex lock nut which is located on the outside of the right wheel bracket. See Figure 4.15.
3. Remove holder, O-ring and bearing.
4. Install new bearing.
5. Carefully install new O-ring over the outside of the new bearing.
6. Install bearing holder and secure with screws.
7. Install 3/8" hex lock nut.

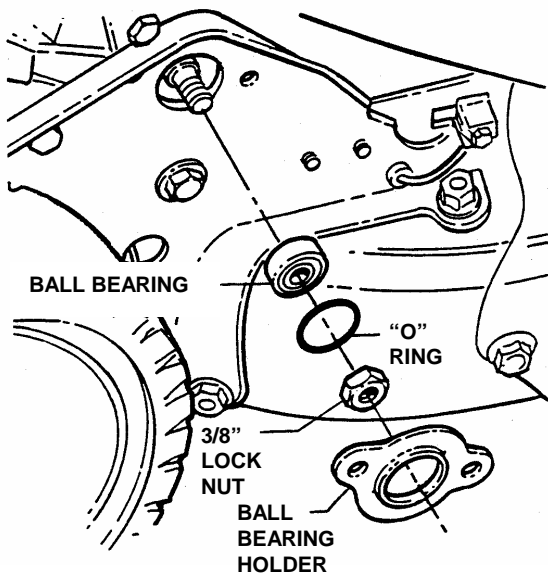

FIGURE 4.15

4.4. BELT SERVICE

On these mowers, the engine belt transmits power from engine to drive disc. The drive disc powers the poly-v belt which engages the transmission that powers the rear wheels. Should these belts become worn, they could cause slippage which would impair mower performance. The condition of the engine belt and poly-v belt should be checked after every 25 hours of mower operation.

4.4.1. Engine Drive Belt Replacement

1. Empty the fuel tank.
2. Unhook the idler spring from the right rear wheel bracket. See Figures 4.16.

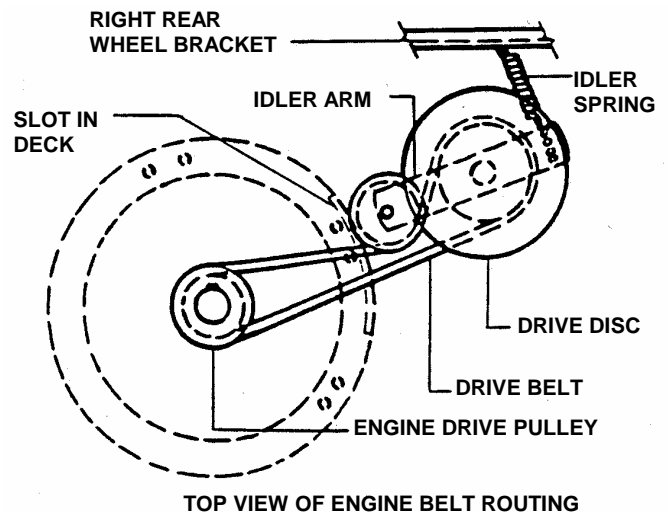

FIGURE 4.16

IMPORTANT: DO NOT tip machine with carburetor or spark plug down. Oil from crankcase will saturate the air filter and cause the engine to be hard to start or not start at all. If contamination does occur, the air filter will have to be replaced.

3. Remove the driven disc. Refer to Section "Replacing Driven Disc Rubber Ring" for driven disc removal procedure.
4. Do not tilt mower with spark plug or carburetor down. Tilt mower up on its rear wheels and remove blade and blade hub. Assistance from another person may be necessary to hold mower in the tilted position.

(Continued On Next Page)

Section 4 - REPAIR & ADJUSTMENTS

WARNING

DO NOT attempt any maintenance, adjustments or service with engine and blade running. STOP engine and blade. Disconnect spark plug wire and secure away from spark plug. Engine and components are HOT. Avoid serious burns, allow sufficient time for all components to cool.

4.4.1. Engine Drive Belt Replacement (Continued from Previous Page)

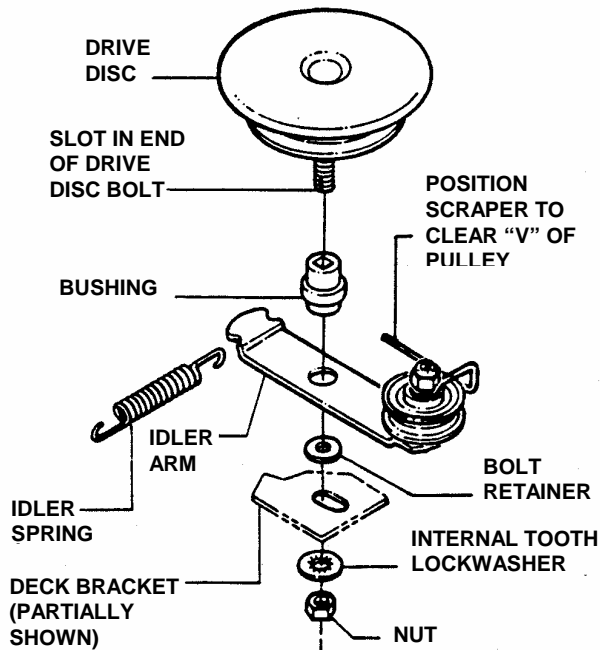

FIGURE 4.17

5. Hold the slotted end of the drive disc bolt with a screwdriver and remove the nut and internal tooth lock washer. See Figure 4.17.
6. Lift the drive disc off the idler arm and remove worn belt.
7. Loop one end of new belt over engine pulley and insert the other end through slot in deck. See Figure 4.17.
8. Loop the belt around the pulley on the bottom of the drive disc.
9. Reinstall drive disc and retaining hardware.
10. Reinstall blade hub and cutter blade. Recommended torque for blade cap screw is 30 to 40 ft. lbs.
11. Use a stiff wire, such as a coat hanger, with a hook fashioned on one end to pull the hooked end of the idler spring through the large hole in the right wheel bracket. See Figure 4.18.
12. Reinstall the driven disc assembly.

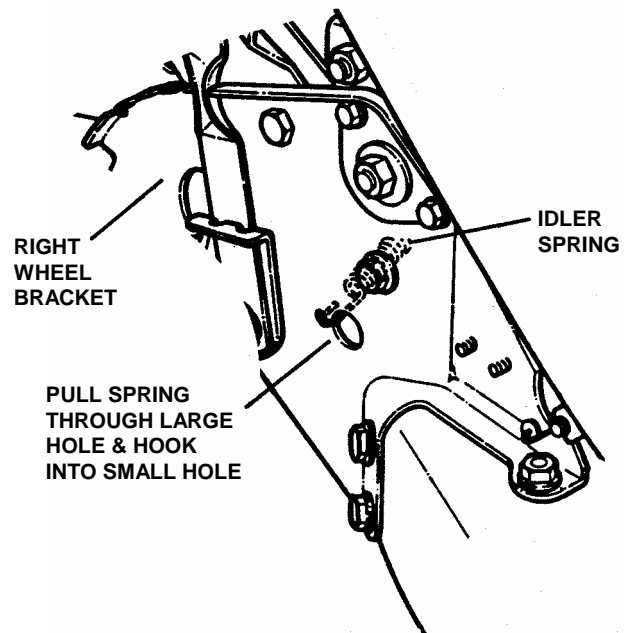
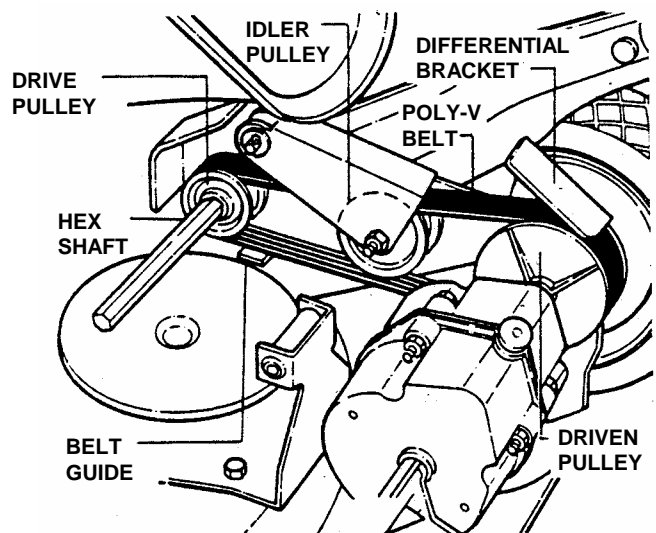

FIGURE 4.18

4.4.2. Transmission Poly-V Belt Replacement



1. Remove the driven disc. Refer to Section "Replacing Driven Disc Rubber Ring" for procedure.
2. Note the routing of the old belt around the three pulleys before removing it. See Figure 4.19.
3. Place new Poly-V Belt over end of hex shaft and onto driven pulley.
4. Work belt onto top of idler pulley.
5. Twist belt sideways and pull it upward between the differential bracket and drive pulley and then down into the pulley groove. Make sure the Poly-V Belt is above belt guide. See Figure 4.19.



ROUTING OF POLY-V BELT

FIGURE 4.19

Section 4 - REPAIR & ADJUSTMENTS

 WARNING 
<p>DO NOT attempt any maintenance, adjustments or service with engine and blade running. STOP engine and blade. Disconnect spark plug wire and secure away from spark plug. Engine and components are HOT. Avoid serious burns, allow sufficient time for all components to cool.</p>



4.5. BATTERY SERVICE

4.5.1. NEW BATTERY PREPARATION

1. Remove battery from carton.
2. Place battery in a well ventilated area on a level non-concrete surface.
3. Remove battery cell caps. Fill cells as required with electrolyte (purchased separately) to proper level. Fill to 3/16" above cell plates. Filling battery with electrolyte will bring the battery to 80% charged state.
4. With cell caps removed, connect battery charger to battery terminals; RED to positive (+) and BLACK to negative (-) terminal.

IMPORTANT: 3/16" above cell plates is the recommended level. Never place anything in battery other than specified electrolyte.

5. Slow charge the battery at 1 amp for 2 hours to bring the battery to full charge.
6. After charging, check level of electrolyte and add as needed to bring level to 3/16" above cell plates.
7. Reinstall cell caps.
8. Install battery into power unit.
9. Connect positive (+) cable (red) first, from wiring harness to the positive terminal (+) on battery using bolt and nut provided in hardware bag. Connect negative (-) cable (black) last, to negative terminal (-) on battery using bolt and nut. Apply a small amount of grease over terminals to prevent corrosion.

 WARNING 
<p>DO NOT over fill battery with electrolyte. Shield the positive terminal with terminal cover located on battery harness. This prevents metal from touching the positive terminal which could cause sparks. The electrolyte (acid) produces a highly explosive gas. Keep all sparks, flame and fire away from area when charging battery or when handling electrolyte or battery. Electrolyte (acid) is a highly corrosive liquid. Wear eye protection. Wash affected areas immediately after having eye or skin contact with electrolyte (acid). Battery acid is corrosive. Rinse empty acid containers with water and mutilate before discarding. If acid is spilled on battery, bench, or clothing, etc., Flush with clear water and neutralize with baking soda. DO NOT attempt to charge battery while installed on the walk behind. DO NOT use "BOOST" chargers on the battery.</p>

4.5.2. BATTERY SERVICE

1. Remove battery.
2. Place battery in a well ventilated area on a level surface.
3. Using distilled water, refill cells as required to cover cell plates of which can also be visualized through the plastic battery case.
4. With cell caps removed, connect battery charger to battery terminals. Red to positive (+) terminal and black to negative (-) terminal.
5. Slow charge battery at 1 amp for 10 hours.
6. If battery will not accept charge or is partially charged after 10 hours of charging at 1 amp, replace with new battery.

4.5.3. BATTERY STORAGE

If Walk Behind is to be stored out of season on its rear bumper, it is recommended the battery be removed, charged and stored.

1. Remove battery.
2. Perform battery service.
3. Bring battery to full charge, if required.
4. Store battery in an area away from the Walk Behind on a wood surface. **DO NOT STORE BATTERY ON A CONCRETE SURFACE.**

4.5.4. BATTERY TESTING

There are two types of battery tests: Unloaded and Loaded. The unloaded test is the procedure that will be discussed. It's the simplest and most commonly used. An unloaded test is made on a battery without discharging current. To perform unloaded testing, check charge condition using either a hydrometer or voltmeter.

1. Using a voltmeter, voltage readings appear instantly to show the state of charge. Remember to hook the positive lead to the battery's positive terminal, and the negative lead to the negative terminal.
2. A hydrometer measures the specific gravity of each cell. The specific gravity tells the degree of charge; generally, a specific gravity of about 1.265 to 1.280 indicates full charge. A reading of 1.230 to 1.260 indicates the battery should be charged. The chart on the next page shows the charge level as measured by syringe float hydrometer, digital voltmeter and five ball hydrometer.

Section 4 - REPAIR & ADJUSTMENTS

4.5.4. BATTERY TESTING

Battery Condition Chart			
State of Charge	Syringe Hydrometer	Digital Voltmeter	Five Ball Hydrometer
100% Charged w/ Sulfate Stop	1.280	12.80v	Five Balls Floating
100% Charged	1.265	12.60v	Four Balls Floating
75% Charged	1.210	12.40v	Three Balls Floating
50% Charged	1.160	12.10v	Two Balls Floating
25% Charged	1.120	11.90v	One Ball Floating
0% Charged	Less than 1.100	Less than 11.80v	Zero Balls Floating

TROUBLESHOOTING

PROBLEM	PROBABLE CAUSE	CORRECTIVE ACTION
Engine Will Not Start Using Electric Starter	1. Battery is dead.	1. Charge or replace battery.
	2. Wiring harness to battery disconnected.	2. Connect wiring harness and tighten securely.
	3. Spark plug wire disconnected.	3. Place spark plug wire onto spark plug.
Engine Will Not Start Using Recoil Starter	1. Fuel tank empty.	1. Fill fuel tank with fresh fuel.
	2. Engine needs choking or priming.	2. Choke/Prime engine. Check Engine Manual for instructions.
	3. Spark plug wire disconnected.	3. Place spark plug wire onto spark plug.
	4. Key switch is not in the "RUN" position.	4. Turn key switch to the "RUN" position.
Engine Stalls or Stops After Running	1. Blade control is released or is not being held securely against handle.	1. Blade control should be held securely against handle at all times during operation of mower.
	2. Fuel tank empty.	2. Fill with fuel to proper level.
	3. Engine air pre-cleaner and or air cleaner dirty.	3. Clean free of all debris.
	4. Spark plug defective or gap set improperly.	4. Service spark plug.
	5. Water, debris or stale fuel in fuel system.	5. Drain and clean fuel system.
Engine Loses Power	1. Engine air pre-cleaner or air cleaner dirty	1. Clean or replace filters.
	2. Spark plug faulty.	2. Service spark plug.
	3. Water, debris or stale fuel in fuel system.	3. Drain and clean fuel system.
Excessive Vibration	1. Damaged, out of balance or bent mower blade.	1. Service mower blade.
	2. Loose blade components.	2. Service and tighten loose parts.
	3. Loose or missing air lift (if equipped).	3. Replace air lifts. Tighten to proper torque.
	4. Lumpy or frayed belt.	4. Replace belt.
	5. Bent Idler pulley.	5. Replace pulley.
Mower Will Not Move Loss Of Traction (Self-Propelled Models)	1. Damaged transmission.	1. Contact authorized SNAPPER dealer.
	2. Traction drive belt requires replacement.	2. Replace traction drive belt.
	3. Driven disc slipping.	3. Clean or replace driven disc.
Cutting Grass Improperly	1. Cutting height too low or high.	1. Adjust cutting height.
	2. Engine speed too slow.	2. Move engine speed control to "FAST" position.
	3. Forward ground speed too fast.	3. Move ground speed control to a slower speed.
	4. Terraced cut, side to side.	4. Adjust height of cut with height adjust levers.
	5. Excessive deck pitch, front to rear.	5. Adjust height of cut with height adjust levers.
	6. Cutting blade dull or damaged.	6. Sharpen cutting edges or replace blade.
Poor Grass Discharge	1. Engine speed too slow.	1. Move engine speed control to "FAST" position.
	2. Forward speed too fast.	2. Move ground speed control to a slower speed.
	3. Grass is wet.	3. Mow when grass is dry.
	4. Excessively worn or damaged blade.	4. Service mower blade.
	5. Build up of grass clippings and debris under deck.	5. Clean deck.
	6. Improper blade installed on deck.	6. Install proper SNAPPER blade.
	7. Blade installed improperly on deck.	7. Install blade properly.
Oil Leaking	1. Leaking engine case.	1. Contact authorized SNAPPER dealer. 2. Check and tighten drain plug. 3. Make sure dip stick or oil filler cap is securely in place.

SERVICE SCHEDULE

ITEM	SERVICE PERFORMED	REF.	EACH USE	5 HRS	25 HRS	50 HRS	100 HRS	EACH SEASON
Engine Oil	Check Oil Level	Page 6	X					
	Initial Oil Change	Page 10		X				
	Periodic Oil Change	Page 11			X*			
Air Pre-Cleaner	Clean Sponge Element	Engine Manual			X**			
Air Cleaner	Clean or Replace	Engine Manual.			X**			
Spark Plug	Replace	Engine Manual.					X	
Engine Cooling System	Clean Shroud & Fins	Engine Manual & Page 6					X**	
Drive Belts	Check For Wear And Tension	Page 11			X	X		X
Mower Blades	Check For Wear, Damage & Replacement	Page 12-13	X					
Mower Deck	Clean Debris Accumulation	Page 6 & 11	X					
Transmission Grease	Check Grease Level	Pages 10-11			X			X
	Periodic Grease Check	Pages 11						X
Drive Disc	Check for Wear Damage & Replacement	Page 13-16				X		
Battery	Check Electrolyte	Pages 19			X			X
	Charge Battery	Pages 19						X
	Testing Battery	Pages 19-20						X

* Change oil every 25 hours when operating under heavy load or high temperatures.

**Clean more often under dusty conditions or when air debris is present

4.6. MAINTENANCE/REPLACEMENT PARTS

MAINTENANCE PARTS	
Engine Speed Control (Briggs Engines)	2-4136
Engine Speed Control (California Briggs Engines)	2-9036
Blade Control Cable	2-5036
Clutch Pull Cable	2-5013
Cutter Blade (Air Lift Compatible)	1-9795
Cutter Blade (Mulching)	1-7168
Cutter Blade (Not Air Lift Compatible)	2-6691
Cutter Blade (Ninja - Quad Edge)	2-6407
Wheel Drive Pulley to Transmission Pulley Belt	1-2354
Engine to Drive Disc Belt	1-2353
Rubber Drive Tire	2-3364
Parts Manual for 21" Steel Deck Electric Start Model Walk Behind Mower Series 12	06060

SNAPPER®

3 YEAR LIMITED WARRANTY

For three (3) years from purchase date for the original purchaser's residential, non-commercial use, **SNAPPER**, through any authorized **SNAPPER** dealer will replace, free of charge (except for taxes where applicable), any part or parts found upon examination by the factory at McDonough, Georgia, to be defective in material or workmanship or both.

For ninety (90) days from purchase date for the original purchaser's commercial, rental, or other non-residential use, **SNAPPER**, through any authorized **SNAPPER** dealer will replace, free of charge, any part or parts found upon examination by the factory at McDonough, Georgia, to be defective in material or workmanship or both.

All transportation costs incurred by the purchaser in submitting material to an authorized **SNAPPER** dealer for replacement under this warranty must be paid by the purchaser.

This warranty does not apply to engines and their components, and batteries, as these items are warranted separately. This warranty does not apply to parts that have been damaged by accident, alteration, abuse, improper lubrication, normal wear, or other cause beyond the control of **SNAPPER**. This warranty does not cover any machine or component part that has been altered or modified changing safety, performance, or durability.

Batteries have a one (1) year prorated warranty period with free replacement if required during the first ninety (90) days from the original purchase date. **SNAPPER** will not be responsible for any installation cost incurred. The battery warranty only covers original equipment batteries and does not cover damage to the battery or machine caused by neglect or abuse, destruction by fire, explosion, freezing, overcharging, improper maintenance, or use of improper electrolyte.

There is no other express warranty.

DISCLAIMER OF WARRANTY

Implied warranties, including those of merchantability and fitness for a particular purpose, are limited to three (3) years from purchase date for the original purchaser's residential or other non-commercial use, and ninety (90) days from purchase for the original purchaser's commercial, rental or other non-residential use, and to the extent permitted by law, any and all implied warranties are excluded. This is the exclusive remedy. Liabilities for consequential damages, under any and all warranties are excluded.

Some states do not allow limitations on how long an implied warranty lasts, or do not allow the exclusion or limitation of incidental or consequential damages, so the above limitation or exclusion may not apply to you.

This warranty gives you specific legal rights, and you may also have other rights which vary from state to state.

WARNING: THE USE OF REPLACEMENT PARTS OTHER THAN GENUINE SNAPPER PARTS MAY IMPAIR THE SAFETY OF SNAPPER PRODUCTS AND WILL VOID ANY LIABILITY AND WARRANTY BY SNAPPER ASSOCIATED WITH THE USE OF SUCH PARTS.

IMPORTANT: Please fill out the attached **SNAPPER** Product Registration Card immediately and mail to:
Snapper's Product Registration Center, P.O. Box 1379, McDonough, Georgia 30253

PRIMARY MAINTENANCE

SNAPPER®

VS. DIRT!

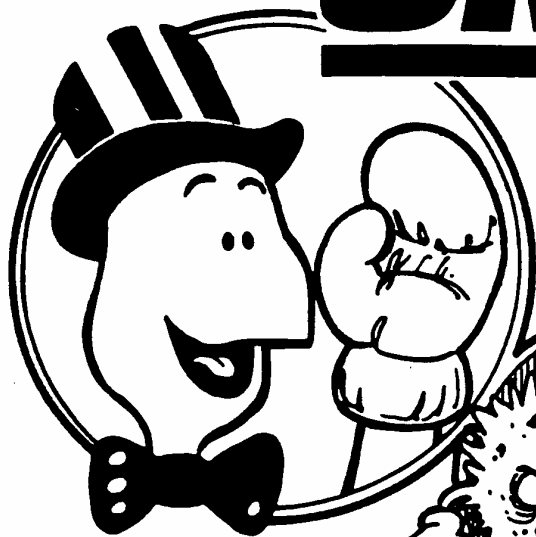

an illustration of how dirt can damage your engine & how reasonable maintenance can protect it!

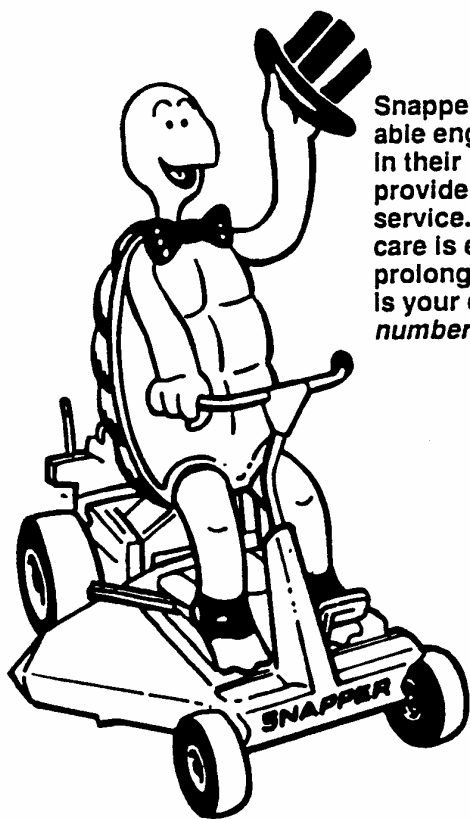

Snapper uses the best available engines and components in their products in order to provide long, satisfactory service. However, proper care is essential in prolonging engine life. Dirt is your engine's enemy number 1!

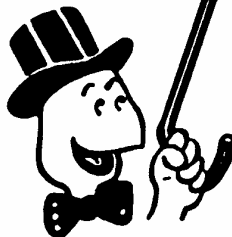

The engine on your Snapper product spends its entire life operating close to the ground at high speed creating a virtual storm of dust and dirt!

PRIMARY MAINTENANCE

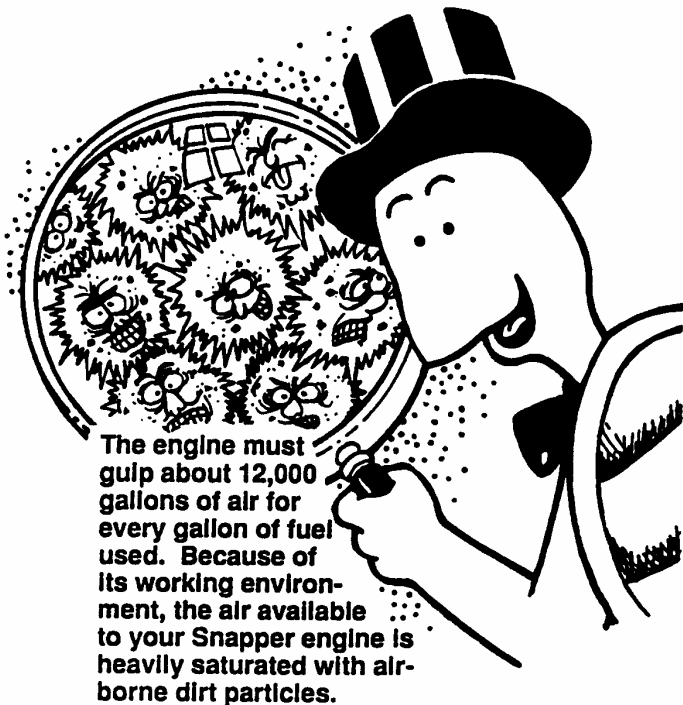

The engine must gulp about 12,000 gallons of air for every gallon of fuel used. Because of its working environment, the air available to your Snapper engine is heavily saturated with airborne dirt particles.

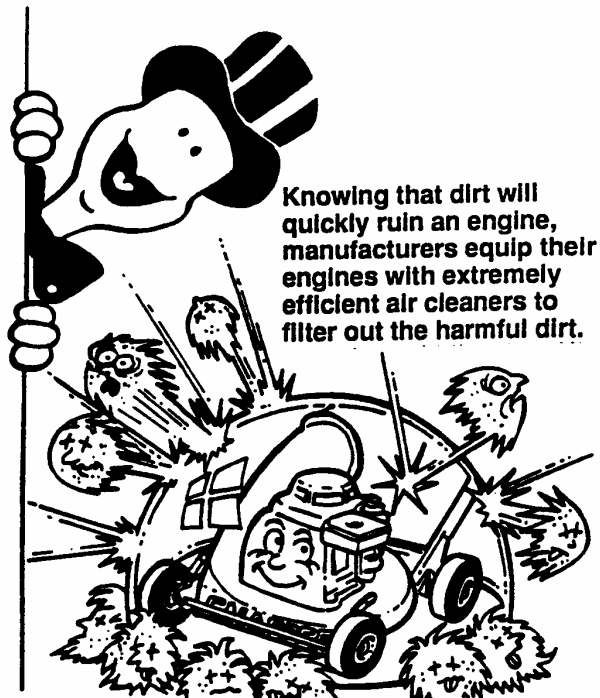

Knowing that dirt will quickly ruin an engine, manufacturers equip their engines with extremely efficient air cleaners to filter out the harmful dirt.

As the dirt particles are stopped, they build up and begin to clog the outside of the filter. This reduces the amount of air available to the engine and causes an over-rich fuel mixture which results in the following adverse effects:

An improperly serviced, dirt clogged air cleaner will:

1. Increase fuel consumption
2. cause power loss
3. result in hard starting
4. create smoke from unburned fuel
5. produce carbon build-up internally
6. foul spark plug electrodes
7. score cylinder walls
8. burn valves
9. wear out the engine prematurely
10. COST YOU MONEY!

Damage caused by a poorly serviced air cleaner is not covered under the engine warranties. So, save yourself unnecessary expenses and undue aggravation by keeping the air cleaner properly serviced at the intervals specified in the engine owner's manual.

It doesn't take long to service an air cleaner. Follow the specific instructions in the engine owner's manual for the type filter used. Prevent dirt from falling into the carburetor intake when servicing your air cleaner. Make sure components are installed in correct sequence after servicing to prevent unfiltered air from entering the engine. Some servicing hints on several common types are:

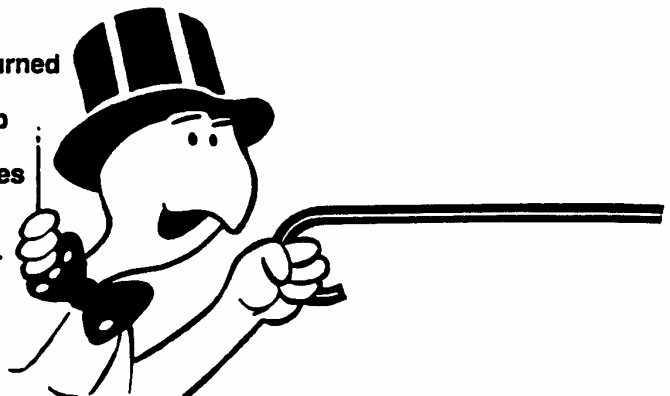
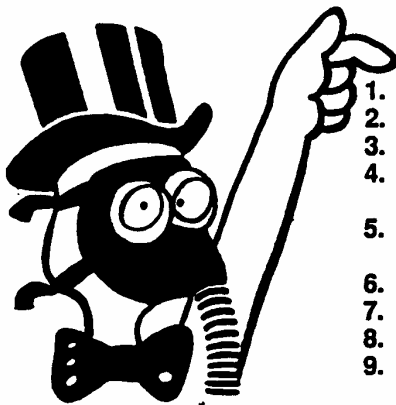

PRIMARY MAINTENANCE

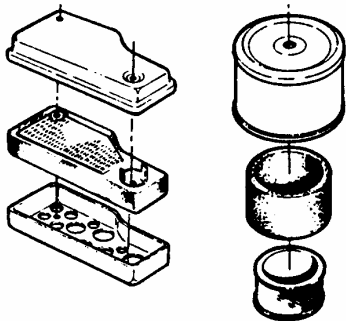

Generally, wash foam-type filters in a dishwashing detergent and water solution. Rinse and wring dry, then saturate with oil and squeeze out excess. *Failure to re-oil this type filter will ruin the engine.*

Clean paper elements by tapping lightly. Blowing with air will rupture paper elements.

Use a flashlight to detect clogged or torn paper elements - replace if damaged in any way.



Air is also needed to keep your engine cool. Dirt, dust & debris build up to restrict and clog cooling air intake screens and fins. Clean screens and fins at frequent intervals. The engine blower housing and shrouds should be removed at least once each season or more often under dry, dusty conditions for a thorough cleaning of fins.

Failure to keep external surfaces clean not only presents fire hazards, but causes overheating and resulting engine damages such as:

1. distorted valve guides
2. sticking valves
3. scuffed, scored cylinder walls
4. overspeeding
5. loss of power
6. complete failure of engine.

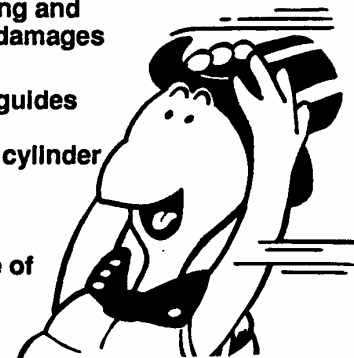
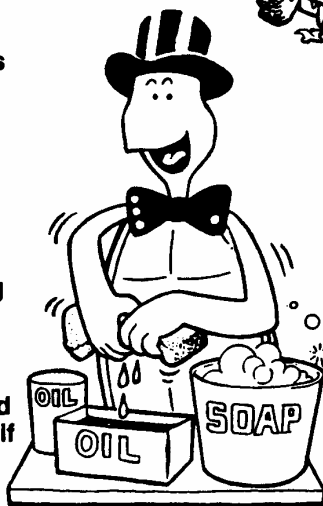

Dirt can also be introduced into an engine in dirty fuel from a contaminated container. Always use clean fresh fuel from a clean container to guard against dirt, sludge and water contamination.



Be aware that fuel breaks down in storage and forms gummy compounds which will block carburetor passages. Never use fuel more than 3 months old. Drain tank then run the engine out of fuel before storing during the off-season.

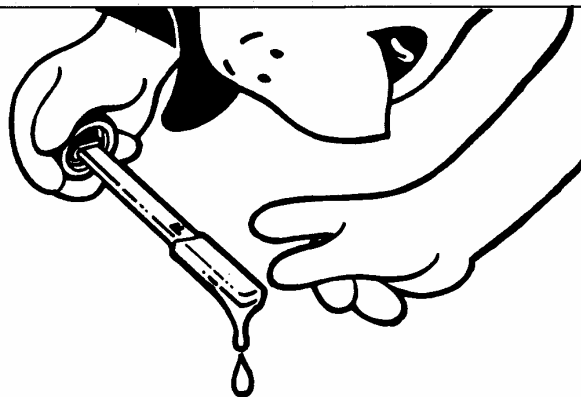

An engine must also have proper lubrication. All engines use some oil. On 4-cycle engines, **CHECK OIL LEVEL BEFORE EACH START-UP.** Wipe area clean around the oil check plug or dipstick opening to keep dirt from falling into the engine when checking the oil. Always check with the machine on a level surface. On engines with dipstick, keep the level up to, but not over, the FULL mark. When adding oil, allow time for all of the oil to flow down the fill tube to prevent a false full reading when the level could actually be low and result in engine damage.

PRIMARY MAINTENANCE

On 4-cyle engines with an oil level plug, don't be fooled into thinking the engine has sufficient lubricating oil if you can see "some" oil in the opening - the level should always be brought up to the point of overflowing at the top of the fill hole.

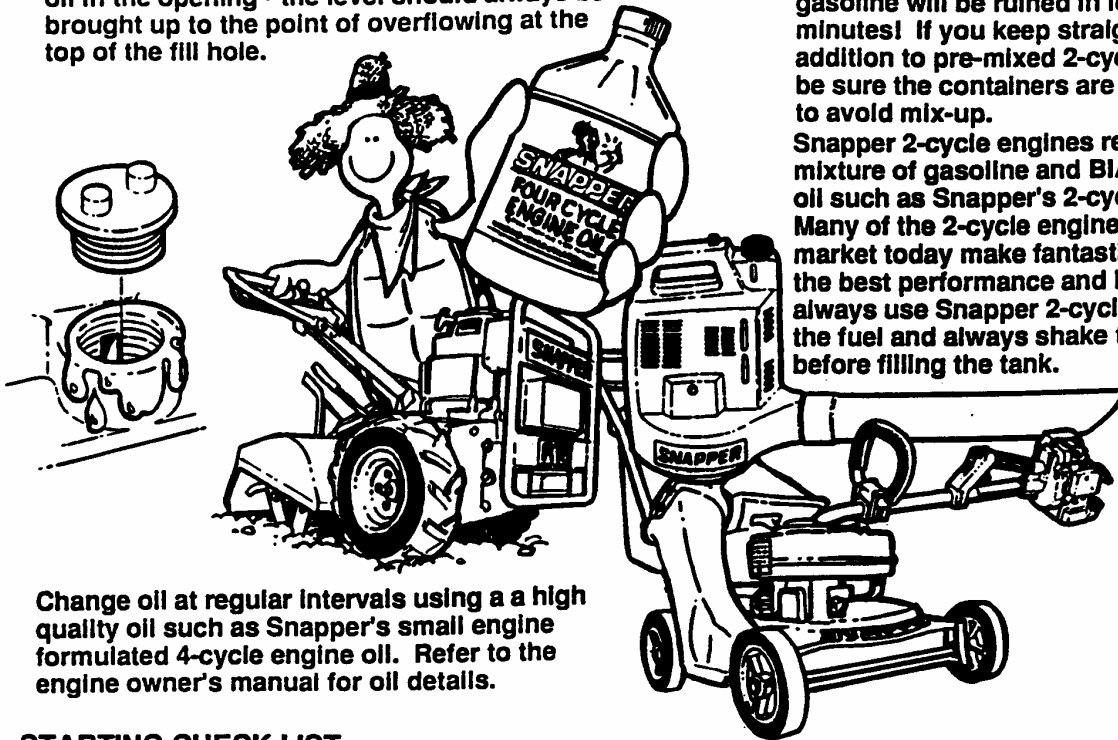

On 2-cycle engines, lubrication must be provided by an exact mixture of gasoline and 2-cycle air-cooled engine oil. A 2-cycle engine that is mistakenly run on straight gasoline will be ruined in less than 5 minutes! If you keep straight gasoline in addition to pre-mixed 2-cycle engine fuel, be sure the containers are clearly marked to avoid mix-up.

Snapper 2-cycle engines require a 32 to 1 mixture of gasoline and BIA certified TC-W oil such as Snapper's 2-cycle engine oil. Many of the 2-cycle engine oils on the market today make fantastic claims, but for the best performance and long engine life, always use Snapper 2-cycle oil. Pre-mix the fuel and always shake the container before filling the tank.

Change oil at regular intervals using a high quality oil such as Snapper's small engine formulated 4-cycle engine oil. Refer to the engine owner's manual for oil details.

STARTING CHECK LIST

- | | |
|-------------------------------|--|
| 1. Engine Oil | <ul style="list-style-type: none"> • To full level (4-cycle) • Properly mixed with gas (2 cycle) |
| 2. Air Cleaner | <ul style="list-style-type: none"> • Clean and properly serviced • Full fresh clean gasoline |
| 3. Fuel Tank | <ul style="list-style-type: none"> • Fuel valve open • Cap vent open • Inline filter clean |
| 4. Choke | <ul style="list-style-type: none"> • Operating properly |
| 5. Primer (on some engines) | <ul style="list-style-type: none"> • Used properly |
| 6. Safety Inter-lock Switches | <ul style="list-style-type: none"> • In proper position • All wires properly connected |
| 7. Switch & Blade Control | <ul style="list-style-type: none"> • Switch On • Blade control properly positioned on walk mower |
| 8. Spark plug | <ul style="list-style-type: none"> • Wire connected • Good connection • Start position |
| 9. Throttle control | |
| 10. Blade | <ul style="list-style-type: none"> • Properly installed and torqued • Sharpened |
| 11. Muffler | <ul style="list-style-type: none"> • Good condition • Not clogged • Grass & leaves cleaned away |

Read and follow all safety instructions in safety booklets and manuals.

Keep in mind that dirt is your engine's *enemy* #1 both internally and externally! Internally, dirt will quickly ruin an engine and externally it will cause overheating and resulting internal damages. Damage caused by improper lubrication, poor air cleaner service or overheating due to dirt cannot be covered under warranty.

It only takes a few moments to service the engine (and equipment) on a routine basis but the rewards will be a quick starting, responsive engine that will provide long satisfactory service with minimum maintenance cost. The prestart checklist in the next column and instructions in your Snapper Operator's Manual are designated to help you keep your Snapper in top operating condition with minimum effort!

Safety Instructions & Operator's Manual for

SNAPPER[®]

**21" STEEL DECK
WALK MOWERS
ELECTRIC START
SERIES 12**

IMPORTANT

Snapper products are built using engines that meet or exceed all applicable emissions requirements on the date manufactured. The labels on those engines contain very important emissions information and critical safety warnings. Read, Understand, and Follow all warnings and instructions in this manual, the engine manual, and on the machine, engine and attachments. If you have any questions about your Snapper product, contact your local authorized Snapper dealer or contact Snapper Customer Service at Snapper, McDonough, GA. 30253. Phone: (1-800-935-2967).

⚠ WARNING: The engine exhaust from this product contains chemicals known to the State of California to cause cancer, birth defects or other reproductive harm.

SNAPPER[®] McDonough, GA., 30253 U.S.A.