

Safety Instructions & Operator's Manual

SNAPPER®

—TOTAL PROTECTION—
WALK MOWERS

BBC

*BLADE
BRAKE
CLUTCH
EQUIPPED

21" HI-VAC --SERIES 8

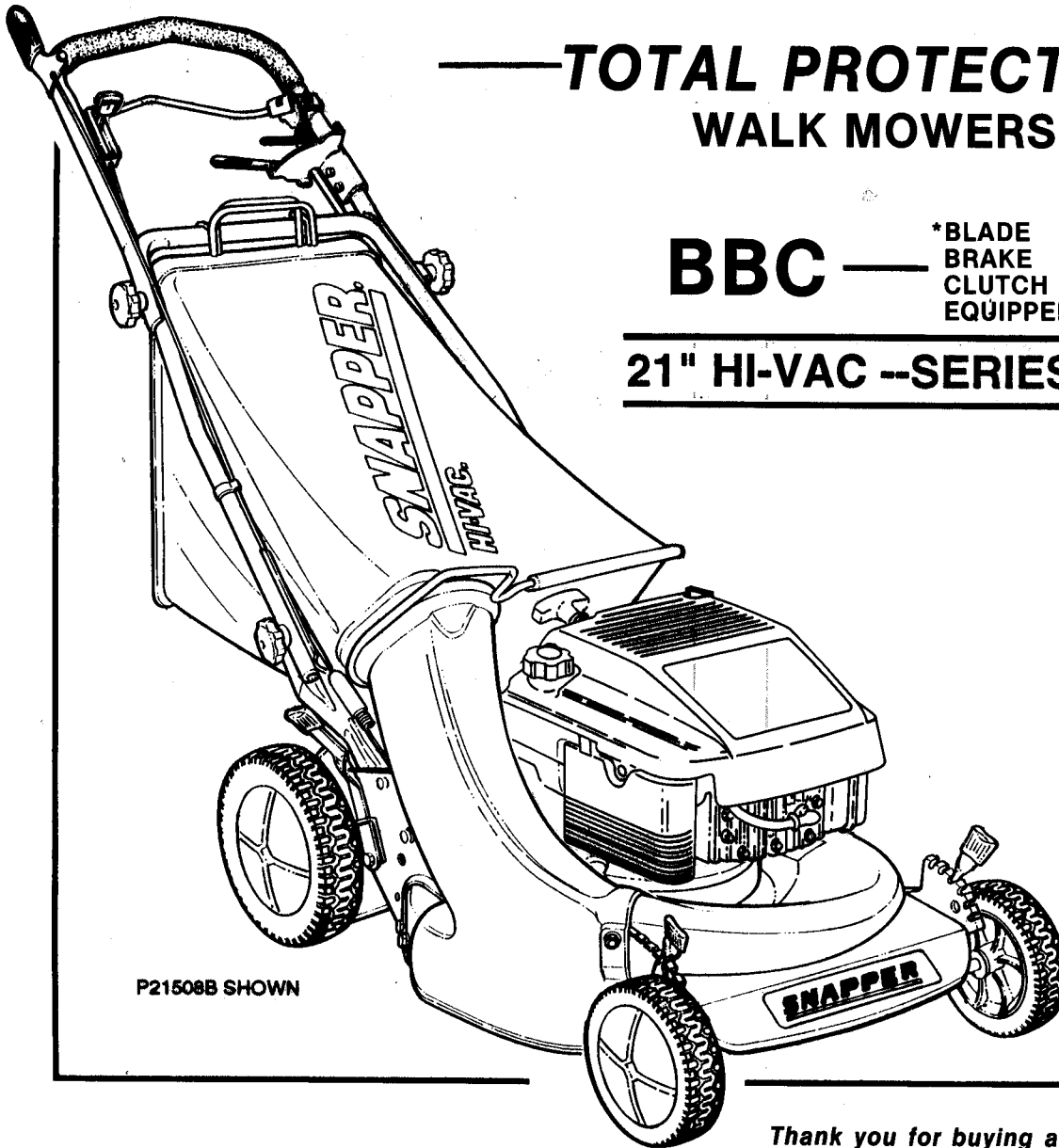

P21508B SHOWN

P21508B

P21558BV

***PRECAUTION: ALTHOUGH THESE BBC MOWERS ARE DESIGNED TO STOP THE BLADE AFTER THE BLADE CONTROL HANDLE IS RELEASED, NEVER PLACE YOUR HANDS OR FEET NEAR THE BLADE WHILE THE ENGINE IS RUNNING!**

*Thank you for buying a SNAPPER product! Before operating your mower, read this manual carefully and pay particular attention to the **Important Safety Instructions** on page 2. Remember that mowers and all power equipment can be dangerous if used improperly and keep in mind that safety requires careful use in accordance with the instructions andcommon sense!*

This manual covers SNAPPER 21" HI-VAC BBC SERIES 8 (last numeral in the five digit model designation) walk behind mowers. Models having a "P" prefix are self-propelled. Models with a "B" suffix are Briggs and Stratton powered. A "V" suffix denotes overhead valve equipped engines.

SNAPPER POWER EQUIPMENT

McDonough, GA., 30253 U.S.A.



#2-2668 (Rev. 1, 3/92)

PRINTED IN U.S.A.

IMPORTANT SAFETY INSTRUCTIONS

WARNING: Failure to comply with the following instructions may result in serious injury to the operator or other persons. The owner of the mower must understand these instructions and, furthermore, must allow only persons who understand these instructions to operate the mower. Each person operating the mower must be of sound mind and body and must not be under the influence of any substance which might impair vision, dexterity, or judgement. If you have any questions pertaining to your mower which your dealer cannot answer to your satisfaction, call or write the Customer Service Department at SNAPPER POWER EQUIPMENT, McDonough Georgia, 30253. (Phone 404-957-9141).

TRAINING

1. Read this Manual carefully and question your dealer if something is not clear. Should the dealer be unavailable or unable to answer to your satisfaction, write or call our Customer Service Department at the factory. Be thoroughly familiar with the controls and proper use of the equipment.
2. DO NOT allow children in yard when mower is operated.
3. DO NOT allow pre-teenager children to operate mower.
4. Allow only responsible teenagers with mature judgement to operate mower and only under close supervision.
5. Keep the area clear of all persons, particularly children.

PREPARATION

1. Never operate mower without proper guards, plates, safety switches, or other safety protective devices in place and properly connected. Inspect to determine that these safety devices are installed properly, are in good repair, and operate properly. If the condition or operation of these devices are questionable, they must be repaired or replaced before using the mower.
2. Thoroughly inspect the area where the mower is to be used and remove all stones, sticks, wire, bones and other foreign objects. Also note the location of holes, stumps, and other possible hazards.
3. Do not operate mower when barefoot or wearing open sandals. Always wear substantial footwear and long pants.
4. Fill gasoline tank before starting engine. Use approved gasoline container. Do not smoke near open gasoline container. Do not fill gasoline tank indoors or when engine is running. Allow engine to cool for at least ten minutes before refilling. Wipe off any spilled gasoline before starting engine. Do not run engine indoors.
5. Make sure that the traction drive clutch control is disengaged before starting engine.
6. Never attempt to make a wheel height adjustment while the engine is running.
7. When mowing over rough ground or in tall grass, mower must be set in highest cutting position.
8. Mow only in daylight or in good artificial light.
9. Never operate mower in wet grass. Always be sure of your footing; keep a firm hold on the handle and walk; never run.
10. Do not operate mower without the grass bag and adapter or the side discharge chute in place.

OPERATION

1. Do not change engine governor settings or overspeed engine.
2. Do not put hands or feet near or under rotating parts. Keep clear of discharge area while engine is running.
3. Stop blade when crossing gravel drives, walks, or roads, and under any conditions where thrown objects might be a hazard.
4. After striking a foreign object or if mower vibrates abnormally, stop the engine, disconnect and secure spark plug wire. Inspect the mower for any damage and repair the damage.
5. Stop engine whenever you leave the operating position behind the handle for any reason, including emptying grass bag and making any adjustments, repairs, or inspections.
6. Before cleaning, repairing or inspecting, make certain blade and all moving parts have stopped. Disconnect and secure spark plug wire away from plug to prevent accidental starting.
7. Stop engine and wait until the blade comes to complete stop before removing grass bag and/or unclogging adapter.
8. Mow across steep slopes, never up-and-down. Exercise caution when changing directions on slopes. Do not mow excessively steep slopes.

MAINTENANCE AND STORAGE

1. Keep all nuts, bolts, and screws tight to be sure mower is in safe operating condition.
2. Never store mower with gasoline in the tank inside of a building where fumes may reach an open flame or spark. Allow engine to cool before storing in any enclosure.
3. To reduce fire hazard, keep mower free of grass, leaves or excessive grease.
4. Check grass bag assembly frequently for wear or deterioration. Replace with new bag if loose seams or tears are evident. Replace broken or cracked parts.
5. Have your mower inspected and serviced each year by an authorized SNAPPER dealer. Determine if any additional devices are available which might upgrade the safety of your mower.
6. Factory specified SNAPPER replacement parts must be used to assure adequate protection against injury.

INTRODUCTION

This manual covers **SNAPPER** BBC Series 8 21" walk behind push & self-propelled mowers. The Series 8 models can (with the proper attachments) bag clippings (GRASS BAG), dislodge and vacuum thatch (THATCHERIZER & GRASS BAG), or vacuum clippings and leaves (SNAPPERIZER & GRASS BAG).

The THATCHERIZER is recommended for self-propelled models. For more complete descriptions, refer to the POPULAR ACCESSORIES section.

KNOW AND OBSERVE THE IMPORTANT SAFETY INSTRUCTIONS WHEN OPERATING THE MOWER!

WARNING: Never place your hands or feet near the blade while the engine is running!
Always disconnect the spark plug wire before inspecting/servicing the blade or mower!

OPERATING PROCEDURE

Know how to stop the mower in preparation for possible emergencies **BEFORE** the first start-up!

For easier starting, move the mower to an area where the blade can turn freely without being restricted by tall grass.

The blade is stopped by releasing the **BLADE CONTROL** (7). Stop the engine by pulling the **ENGINE CONTROL** lever (10) rearward to the **STOP** position. Releasing the **WHEEL DRIVE** control (20) stops the forward movement of the mower. Refer to **FIG. 1** for locations of controls.

OPERATING/SERVICE POINTS

- 1 : ADJUSTING LATCH (HEIGHT)
- 2 AIR BREATHER (COVER)
- 3 BAG
- 4 BAG ADAPTOR
- 5 BAG CONNECTOR
- 6 BAG WIRE SUPPORT
- 7 BLADE CONTROL
- 8 DECK
- 9 ENGINE
- 10 ENGINE CONTROL LEVER
- 11 FUEL FILLER CAP
- 12 GROUND SPEED CONTROL
- 14 LOWER HANDLE
- 15 OIL FILLER (DIPSTICK)
- 16 PIVOT
- 17 ROPE START HANDLE
- 19 UPPER HANDLE
- 20 WHEEL DRIVE CONTROL
- 21 KNOB
- 22 HUBCAP

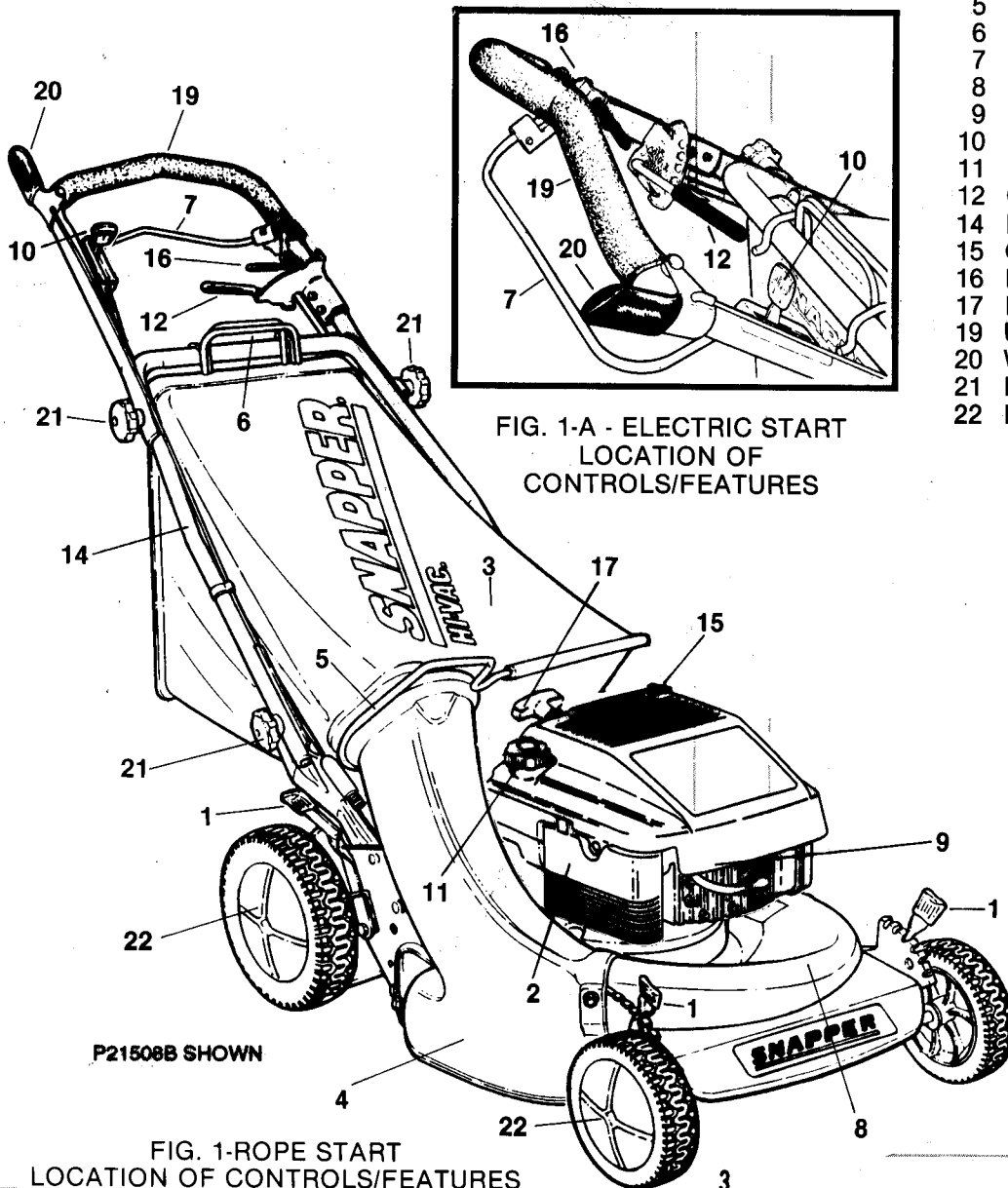

FIG. 1-A - ELECTRIC START
LOCATION OF
CONTROLS/FEATURES

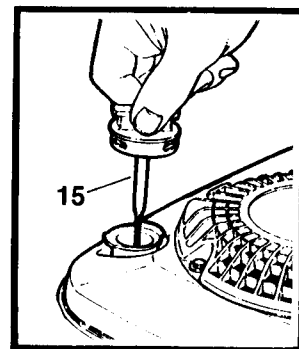

FIG. 2
DIPSTICK
LOCATION

FIG. 1-ROPE START
LOCATION OF CONTROLS/FEATURES

PRE-START CHECKS

Prior to each start-up, check/service as needed:

•**CHECK** guards, BAG (3) BAG ADAPTOR (4) or side discharge chute for proper position and tightness.

•**NOTE:** The "tab" on the inside rear edge of the adapter or side chute must push the interlock spring in toward the center of the mower. If the tab is improperly installed, the engine **CAN NOT** be started.

•**CLEAN** surfaces to remove dust, dirt, and clippings - particularly from the cooling air intake screen on engine to prevent overheating.

•**CHECK** oil level in 4-cycle engines and add oil as needed to bring the level up to but not over the dipstick (15) "FULL" mark. Refer to FIG. 2.

•**CHECK** cutting height and adjust as needed, to suit the prevailing grass conditions. Refer to FIG. 5.

•**CHECK** fuel level in tank after pushing mower outdoors where fumes will safely dissipate.

STARTING/STOPPING ENGINE

NOTE: Stop the blade by releasing the **BLADE CONTROL**. Stop the engine by moving the **ENGINE CONTROL** rearward to **STOP** position.

ROPE START:

1. Move **ENGINE CONTROL** lever to **CHOKE** position.
2. Place left foot on top of left rear tire with toes pointing forward.
3. Bend at waist to reach **ROPE START HANDLE** (17) and straighten up as you pull handle—using back muscles more than arm muscles.
4. Continue pulling **ROPE START HANDLE** until the engine starts. Guide rope slowly back into engine shroud to prevent rope breakage which could result if the handle is allowed to snap back.

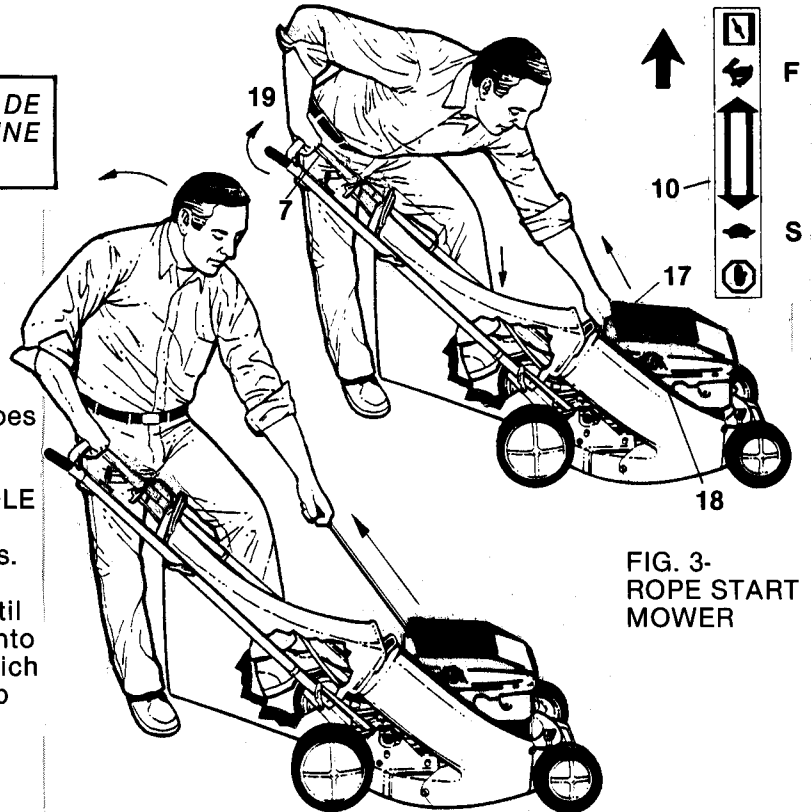

FIG. 3-
ROPE START
MOWER

STARTING/STOPPING BLADE

NOTE: Two separate and deliberate actions are required to start the blade. Refer to FIG. 6 and start the blade as follows:

1. Move the mower to an area which has short or sparse grass.
2. Push the **PIVOT** (16) down to the bottom of the slot and hold.
3. Pull the **BLADE CONTROL** (7) back against the **UPPER HANDLE** (19). Set the **ENGINE CONTROL LEVER** (10) in the fast (F) position.
4. Permit the engine 3 seconds to reach maximum RPM before starting to mow, thus avoiding slippage of the clutch which could result in excessive wear.

FIG. 6
MOWING CONTROLS

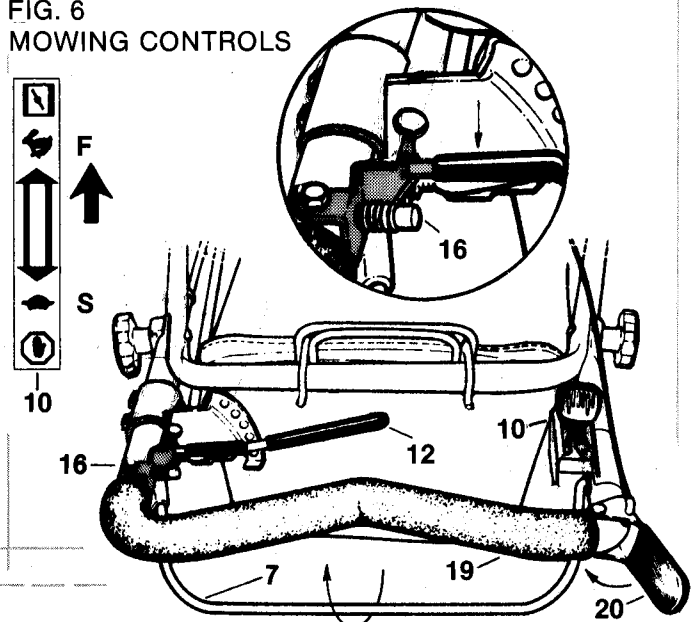

CUTTING HEIGHT ADJUSTMENT

ALWAYS STOP THE ENGINE BEFORE RE-ADJUSTING CUTTING HEIGHT!

It is recommended that no more than 1/3 the height be cut from the grass.

EXAMPLE: If the grass is 4" tall, set the four ADJUSTING LATCHES (1) in notch 6 (the highest blade setting) which will leave the grass at approximately 3-3/8" tall after cutting—well within the 1/3 off limit. If you prefer shorter grass, wait a few days before recutting at a lower setting. If cut short too frequently, the root system will be more subject to burning, due to energy being expended toward the development of new leaf structures rather than the necessary development and reinforcement of a good healthy root system!

If allowed to grow too tall, the lower portion (which will then be shaded) will discolor.

To re-adjust mower cutting height, pull each of the four height ADJUSTING LATCHES (1) outward toward the wheel and then slide into the desired notch. Set both latches on one side and then set the two on other side into corresponding notches. When setting the rear latches into LOWER notches, raise the rear wheels off the ground to ease operation.

NOTE: The highest cutting position is attained with the four latches set in notch 6. The lowest cutting position is with latches set in notch 1. Refer to FIG. 5.

Changing your mowing pattern from time to time creates a smoother cut lawn. Finely chopped clippings add nutrients to the soil—promoting grass growth! However, if accumulation becomes too heavy, matting can develop and "thatch" forms and prevents breathing, holds excessive moisture, and can destroy root structure! The **SNAPPER** Thatcherizer Kit #6-0476 can prevent the development of thatch. Dislodged thatch can be vacuumed with your mower if it is equipped with the grass bag. If your **SNAPPER** is side discharge equipped, it can be easily converted to a bagger and back to a side discharge unit as often as desired! Refer to the ACCESSORIES section for kits available for your mower!

MOWING PROCEDURE

Set the ENGINE CONTROL lever (10) in the fast (F) position for thick grass, AND slow down (reduce "Ground Speed") OR narrow the cut to less than the full blade width.

Set the GROUND SPEED CONTROL lever (12) in the desired setting and then grasp the WHEEL DRIVE CONTROL (20) and hold against the UPPER HANDLE (19) to engage clutch. To stop the mower's forward movement, release the WHEEL DRIVE CONTROL - the mower can then be pushed forward or pulled for trimming.

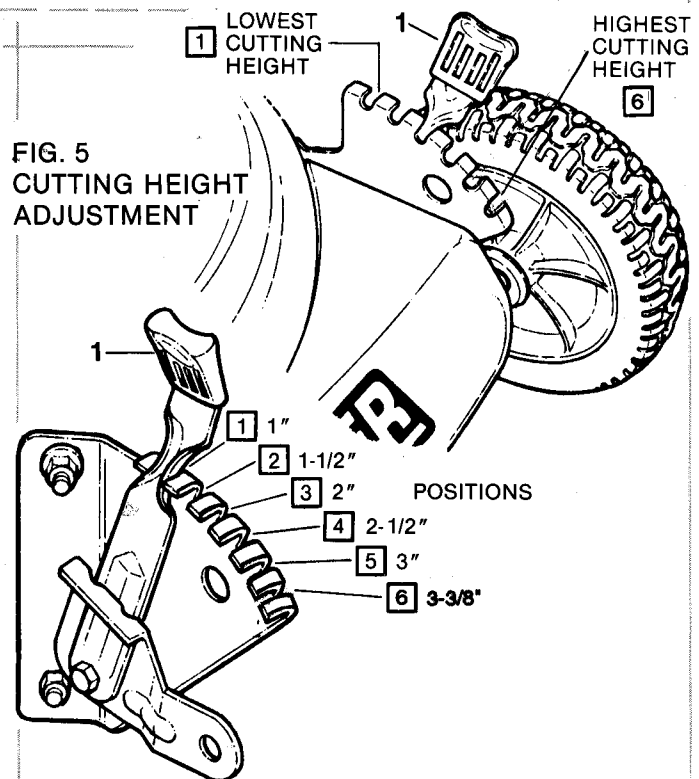

FIG. 5
CUTTING HEIGHT
ADJUSTMENT

During dry seasons, allow the grass to grow taller than normal. Refer to FIG. 5-A.

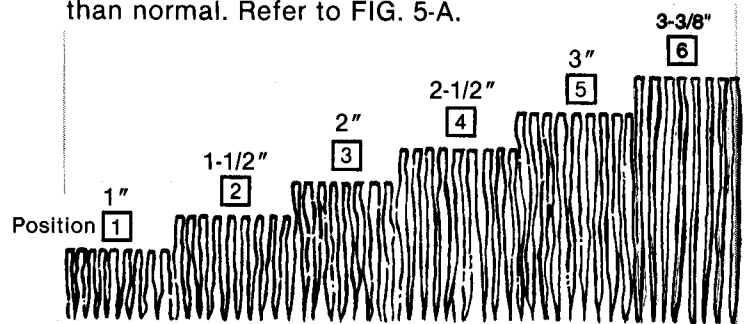

FIG. 5-A CUTTING HEIGHT SETTINGS

MOWING/VACUUMING HINT: THE MOWING DECK SHOULD BE LEVEL UNDER ALL CONDITIONS.

NOTE: Following the use of a dry-type fertilizer, it is recommended that the lawn be sprinkled BEFORE using the mower - to avoid vacuuming up the fertilizer.

Experiment and adjust the ENGINE CONTROL lever and the GROUND SPEED CONTROL until the mower functions best for your turf conditions. The speed of forward movement can be varied while the mower is moving by changing the GROUND SPEED CONTROL setting as desired. Remember - PIVOT (16) and BLADE CONTROL (7) engages the blade.

NOTE: Stop the blade by releasing the BLADE CONTROL. Stop the engine by moving the ENGINE CONTROL rearward to the STOP position.

NOTE: When mowing down-hill, use a "low" setting on the GROUND SPEED CONTROL lever, and brake by engaging and disengaging the WHEEL DRIVE CONTROL (CLUTCH).

EMPTYING GRASS BAG

When the grass bag becomes full, stop engine and lift the BAG WIRE SUPPORT hooks (6) up over the LOWER HANDLE (14) and then lift the BAG CONNECTOR (5) off the adaptor flange and continue lifting while moving the bag forward until it clears the mower. To empty the bag, raise the connector end up and release the handle of the door flap. Shake the bag back and forth to dump the clippings. Refer to FIG. 7.

To re-install the bag, slide the BAG CONNECTOR down over the adaptor flange, then lower the BAG WIRE SUPPORT hooks onto the LOWER HANDLE.

TO EMPTY INTO TRASH BAG: After removing the grass bag from the mower, place CONNECTOR end on ground, open door flap, slip a trash bag over the end (BAG WIRE SUPPORT end), and then turn the mower bag over so that the large opening is inside trash bag. Lift bag- by the CONNECTOR and door handles and shake until clippings are dumped into the trash bag.

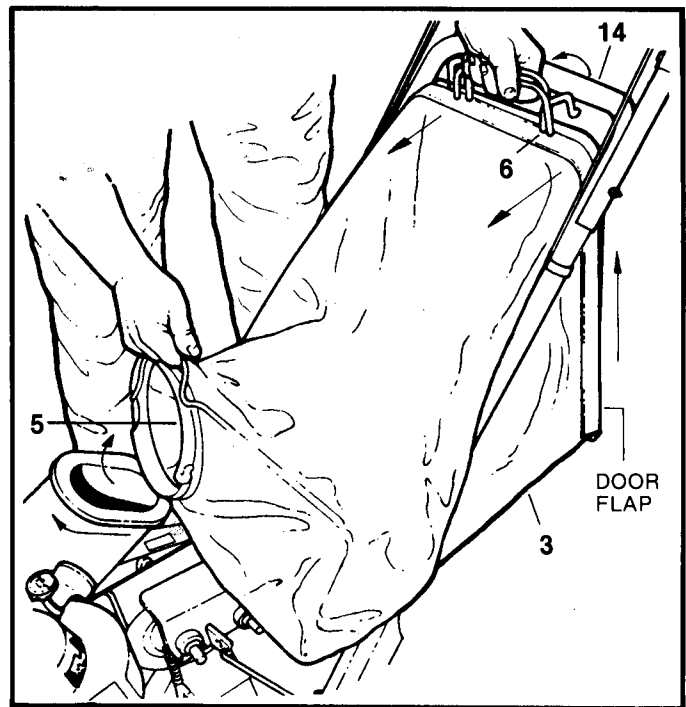

FIG. 7-EMPTYING GRASS BAG

SERVICE PROCEDURE

Your **SNAPPER** mower requires very little service, however, it is important that the engine be serviced at the intervals specified in the engine manual furnished with your mower.

To retain the integrity of your mower, only use Genuine **SNAPPER** Replacement Parts.

By returning your mower to an Authorized **SNAPPER** Dealer on a yearly basis for inspection and addition of any new devices to upgrade your mower, the reliability of the unit's functions will be assured.

Check the yellow pages under **LAWN MOWERS** for the nearest **SNAPPER** Dealer. Always mention the model and serial number of your mower when contacting the dealer for information, parts, or service.

LUBRICATION SCHEDULE

• **ENGINE:** Change oil every 25 hours as specified in engine manual; check oil level before each use.

Always disconnect the spark plug wire BEFORE draining the oil!

To drain oil from series 8 BBC model, tip the mower over on its **LEFT** side and permit the **UPPER HANDLE** to touch the ground surface. Place a shallow container under the dipstick/filler tube area and remove the dipstick, allowing the oil to drain into the container.

NOTE: Due to the location of the blade brake clutch mechanism, the oil drain plug (in the underside of engine) cannot be used to drain oil in the conventional manner.

WARNING: Always disconnect the spark plug wire from the spark plug when inspecting/servicing the mower - to prevent unintentional engine start-ups.

NOTE: When tipping the mower to work on the underside, always tilt it on the **LEFT** side to prevent flooding the engine with gasoline and/or oil, which would cause hard starting after servicing.

For engine parts/service, check the yellow pages under the heading **ENGINES - gasoline**, for the nearest engine manufacturer's dealer.

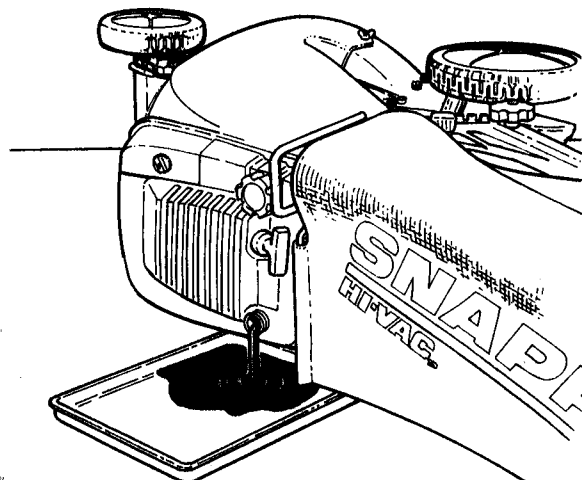

FIG. 8 - OIL DRAIN PROCEDURE

• **TRANSMISSION (on the self-propelled models):**

The transmission is filled with 4 ounces of *SNAPPER* "00" grease at the factory and under normal usage, will not require additional grease. It is recommended that plug (A) be removed after every 25 hours of operation, and a visual determination of the lubrication condition of the transmission be made. If grease IS NOT visible on the INPUT GEAR (the small gear below the plug opening), add a small amount of *SNAPPER* "00" grease. Reinstall the plug (A) after servicing the transmission. Refer to FIG. 8-A.

SNAPPER "00" grease is available in a convenient squeeze container (Part No. 6-1017) at your *SNAPPER* Dealer.

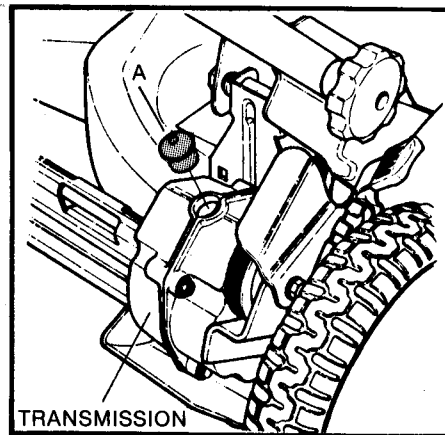
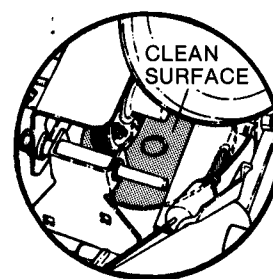

FIG. 8-A - TRANSMISSION PLUG A



NOTE: DO NOT spill oil on the surface of drive disc.

CUTTING BLADE SERVICE

WARNING: Always disconnect the spark plug wire and secure the end away from the plug before inspecting/servicing the blade, to prevent unintentional start-ups.

Inspect blade at frequent intervals for tightness and condition.

Refer to FIG. 9 for blade condition. Replace the blade if it is badly chipped, bent, noticeably out of balance, or has a notch worn in either tip - as shown in example B.

The B wear pattern occurs more rapidly under sandy soil conditions and appears between the flat surface and upturned "lift" lip at each end of blade tip.

WARNING: Never operate the mower with a blade worn to the extent shown in example C - the "tip" could fly off and cause personal injury or property damage.

BE CAREFUL: AVOID CUTTING YOURSELF ON A SHARP BLADE! Wear gloves to protect your hands while handling the blade.

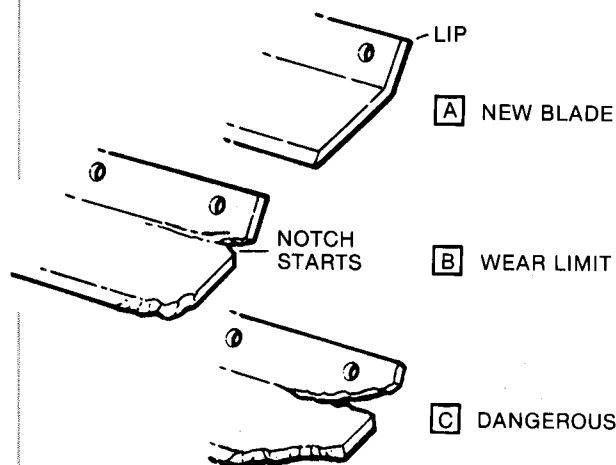

FIG. 9-BLADE WEAR PATTERNS

When the blade's cutting edges have become dull (while in otherwise good condition), sharpen on a grinding wheel at an angle of 22 to 28 degrees. The cutting surface (on each end) should extend inward about 3-1/2" from the tip. After sharpening, check the blade for balance - a blade "out of balance" will cause excessive vibration. Re-balance as required.

Re-install the blade with the components in proper sequence as shown in FIG. 10.

DO NOT substitute any components! When re-installing the blade, be sure the two special blade spacers (A) sit on the upper surface of the blade BETWEEN flange (X) and flange (Y). Then fasten the blade to the underside of the clutch assembly using the two cone washers (B) with the widest part UP, and the two special capscrews (C) - and tighten to 20/30 FOOT POUNDS.

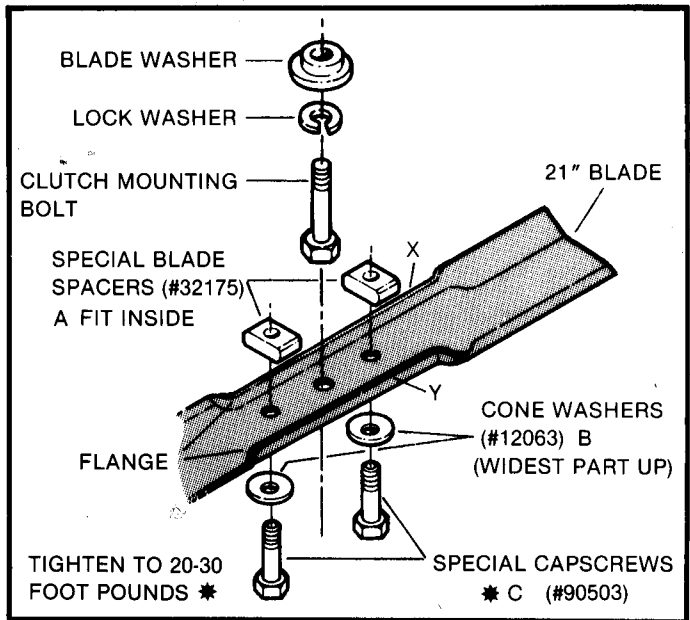

FIG. 10 - BLADE RETENTION DETAIL

CLUTCH LINKAGE

The vinyl (tube type) cover (A) should always conceal outer (B) and inner (C) clutch cable springs. The spring combination connects the clutch cable to the clutch idler components (refer to FIG. 11). The cover (A) prevents accumulation of dirt on the springs and eliminates the possibility of their wearing a hole through a grass bag.

ADJUSTMENT: Should excessive pressure be required to hold the WHEEL DRIVE CONTROL lever (20) against the UPPER HANDLE (19), spring adjusting is needed! Refer to FIG. 11.

When properly adjusted, there should be 1/16" to 1/8" clearance between the INSIDE of spring (B) hook and the INSIDE of the clutch cable "eye". Stop the engine and release the WHEEL DRIVE CONTROL lever/and pull back cover (A) to check clearance.

To adjust, unhook springs from cable (at "eye") and rotate springs in opposite directions and re-hook to cable and check clearance. Repeat procedure if needed.

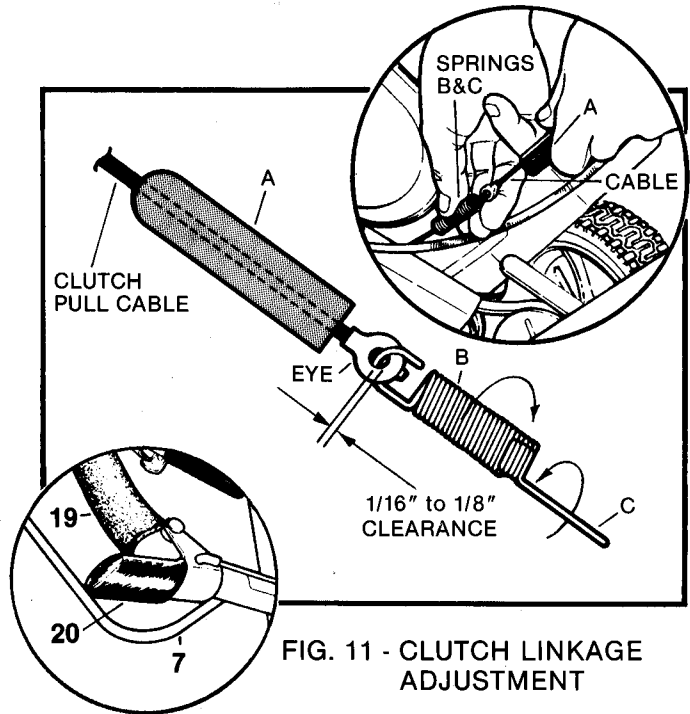
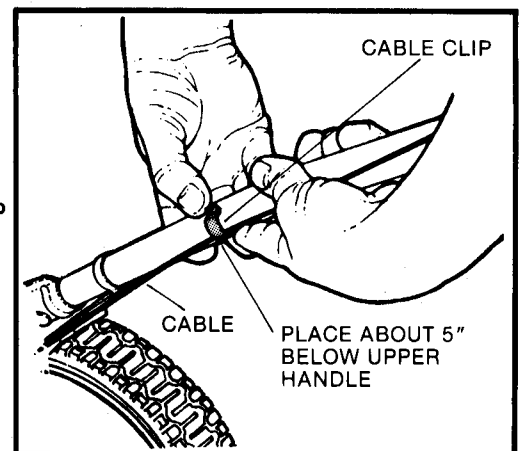

FIG. 11 - CLUTCH LINKAGE ADJUSTMENT

If the WHEEL DRIVE CONTROL lever fails to "snap" back when released, check for binding at the cable holding clip located on side of handle - it should be about 5" below the upper handle and permit the cable to slide freely. Refer to FIG. 11-A.

FIG. 11-A CABLE CLIP



DRIVEN DISC SERVICE

If the mower does not pull properly, refer to FIG. 12, and check for the following:

- Grease on drive disc (C)-causing slippage.
- Broken or disconnected DRIVE SPRING (D) (also refer to FIG. 14).
- Driven disc rubber ring (B-1) worn - not contacting drive disc (C) properly.
- Driven disc (B) out of adjustment
- Worn belts

DRIVEN DISC ADJUSTMENT

The driven disc should be properly adjusted for optimum operation, minimum rubber ring wear, smooth shifting, and to prevent the mower from jumping out of gear due to misadjustment. If the clutch is properly adjusted, and both belts are in good condition (or are new), check the two adjustments and correct if necessary.

Check the "**DISTANCE**" from the **CENTER** of the driven disc's rubber ring to the **left EDGE** of the drive disc.

1. Shift the **GROUND SPEED CONTROL** into the highest setting, and **STOP** engine. The **CENTER** of the rubber ring should be $1/8"$ to $1/4"$ from the **left EDGE** of drive disc as shown. To re-adjust, loosen connector hex nut (A-1) then slide the driven disc **LEFT** or **RIGHT** (on hex shaft) as required. Re-tighten connector hex nut.

Check the "**TRACKING POINT**". The rubber ring should contact the drive disc's surface at a point $1/8"$ **in front of** an imaginary reference centerline crossing through the center of the drive disc. You may wish to draw the centerline with a pencil.

When properly adjusted, the rubber ring will "Track" (run) **in place** approximately half way between the center of the drive disc and its **left EDGE**, with the transfer rod (F) disconnected and the engine running. Perform this test before making adjustment number 2.

DRIVEN DISC REPLACEMENT: If the driven disc rubber ring (B-1) is found to be badly chunked or worn down to within $1/16"$ of the metal rim of the driven disc hub (B), it must be replaced. Remove the clip (E) at end of speed control rod, and then turn the transfer rod (F) to a upright (vertical) position and detach from the connector (A) (FIG. 14 & 15). Unhook drive spring (D) (use needle nose pliers) and slide the driven disc assembly off hex-shaft.

Remove the five machine screws (G) and plate securing the driven disc rubber ring (B-1) to the hub (B) and replace the ring as shown in FIG. 15. Reverse procedures for re-assembly and installation.

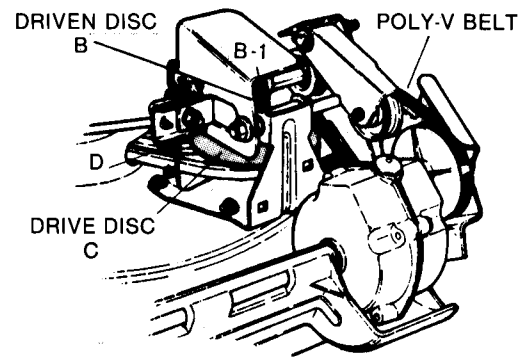

FIG. 12 -DRIVEN DISC

2. Re-adjust "Tracking", by imagining (or drawing) a reference line **across** drive disc center; loosen hex nut (W) securing thrust plate guide (X) to thrust plate (Y) at slot (Z).

Move driven disc (with thrust plate Y) **FORWARD** or **REARWARD** until the rubber ring contacts the drive disc surface $1/8"$ **in front of** the imaginary reference centerline. Re-tighten hex nut (W). Perform the test again before reattaching transfer rod (F).

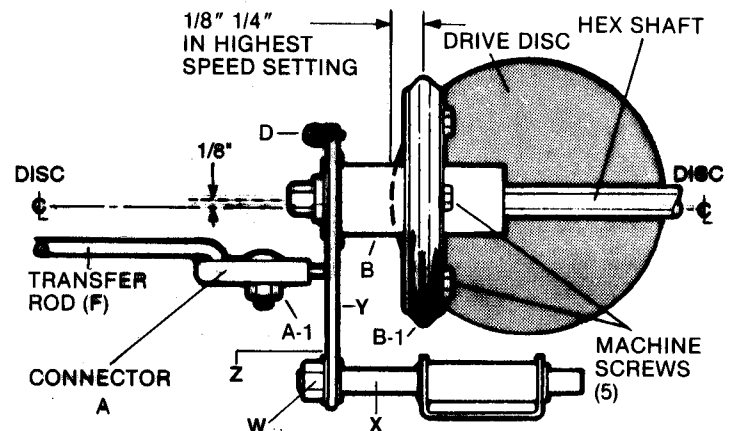

FIG. 13 -DRIVEN DISC COMPONENTS

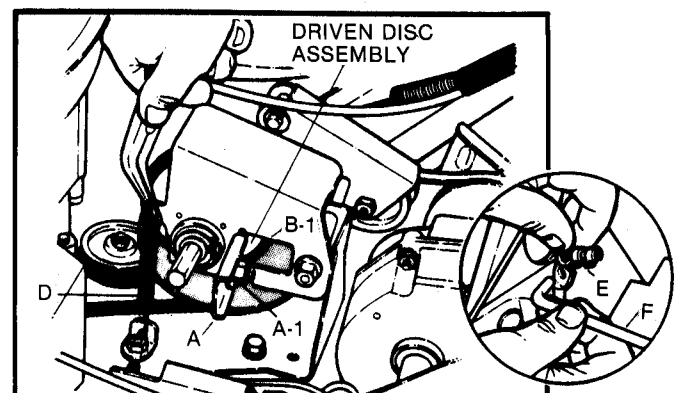

FIG. 14 -DRIVEN DISC ASSEMBLY

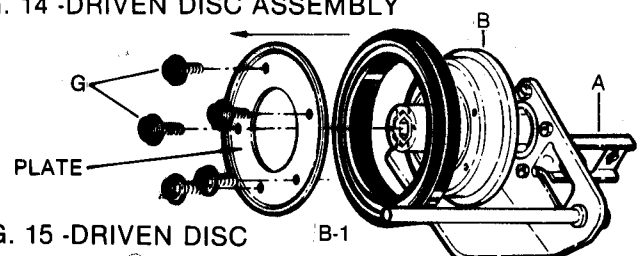

FIG. 15 -DRIVEN DISC

BEARING REPLACEMENT: If the driven disc bearing fails, remove the complete driven disc assembly as previously described. Then remove the snap ring (H) (special pliers are required) and slide the driven disc assembly out of bearing.

Remove the four retaining screws (I) and then the bearing (J). Re-assemble in reverse order. Refer to the illustration FIG. 16.

To replace the bearing on pulley end of hex-shaft, hold the shaft with an adjustable wrench (next to the pulley). Then remove the 3/8" retaining hex lock nut (located on outside of right rear wheel bracket). Carefully remove holder, O-ring, and bearing and replace the bearing. Re-assemble and carefully re-install the O-ring over the outside of new bearing -securely tighten the two retaining screws as shown in FIG. 16-A.

BELT SERVICE

Slippage (from worn belts) can prevent a mower from maintaining optimum performance! The engine belt transmits power to the Poly-V-Belt, which in turn, engages the clutch to drive the transmission and rear drive wheels.

ENGINE BELT REPLACEMENT

NOTE: It is recommended that individuals who **ARE NOT** mechanically inclined, consult their **SNAPPER** dealer concerning belt replacement on BBC mowers.

Disconnect the spark plug wire and empty the fuel tank (or tape the vents in the filler cap closed to prevent fuel spillage).

Unhook the idler arm spring (A) from the right rear wheel bracket. Remove the driven disc assembly (see DRIVEN DISC section). Tilt the mower on its **RIGHT** side and remove the cutting blade, spacers, bowl & brake assembly, clutch bearing assembly, and flywheel assembly. Remove drive disc retaining nut (B) and lockwasher (C). Raise the drive disc from its position on the idler arm and remove the worn belt. Loop one end of the replacement belt over the engine drive pulley (D); and insert the other end through the deck opening and loop it around the driven pulley (on underside of drive disc). Lower the disc into position on the idler arm and through deck. **NOTE:** The idler must press against the belt-**after** (A) has been re-attached to the wheel bracket.

Re-install (C) and then (B) on drive disc stud-securely tighten (B). Test arm pivoting action- **IT MUST PIVOT FREELY!** Use a coat hanger or a piece of stiff wire with a hooked end to pull spring A's hooked end through the large hole, and then the smaller hole in wheel bracket. Re-install flywheel assembly, clutch bearing assembly, and re-attach the bowl & brake assembly to the stand-offs with the (3) 3/8" hex flange locknuts. Follow the explanation in the **BLADE SERVICE** section to re-attach the blade. If the Poly-V-Belt is **NOT** going to be replaced, re-install the driven disc assembly.

DRIVEN DISC ASSEMBLY

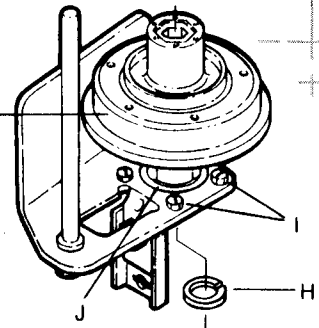

FIG. 16
BEARING REPLACEMENT

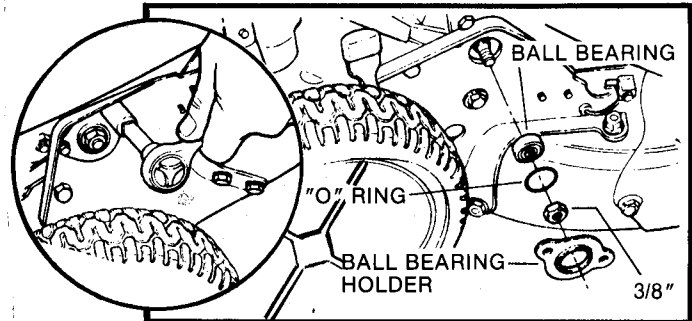
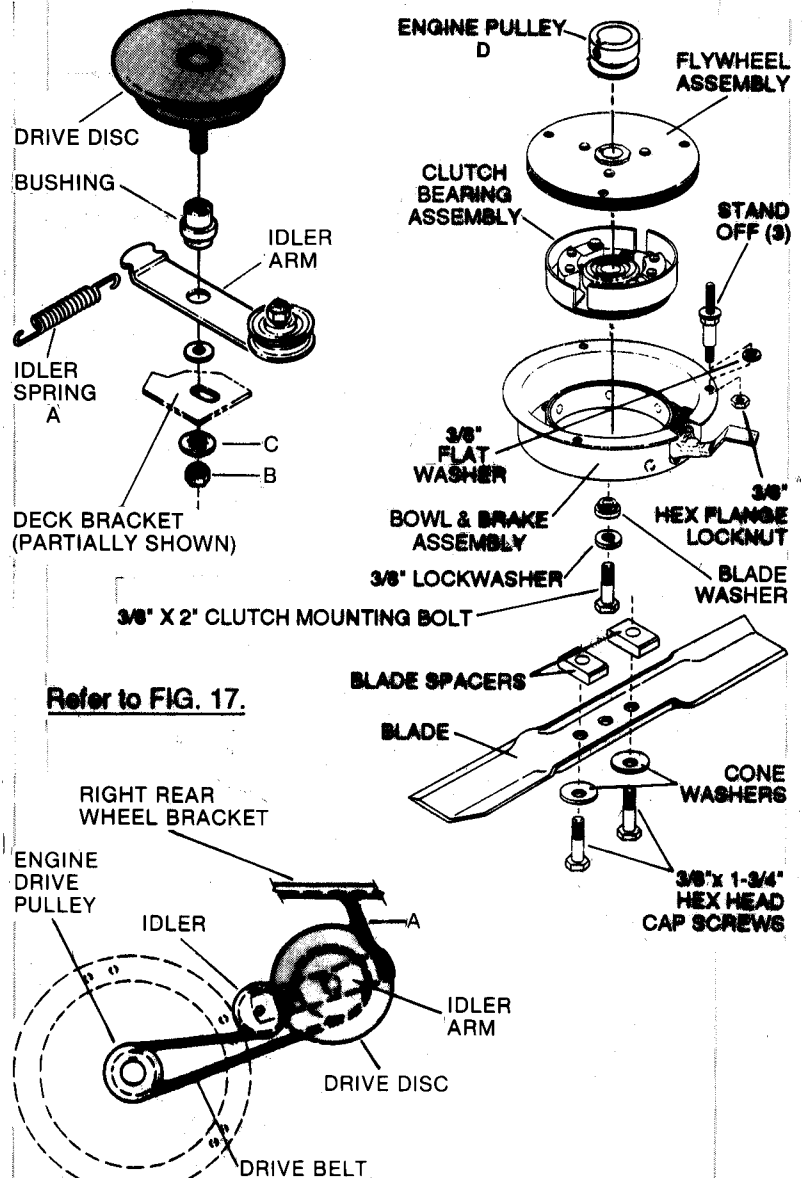

FIG. 16-A BEARING REPLACEMENT



Refer to FIG. 17.

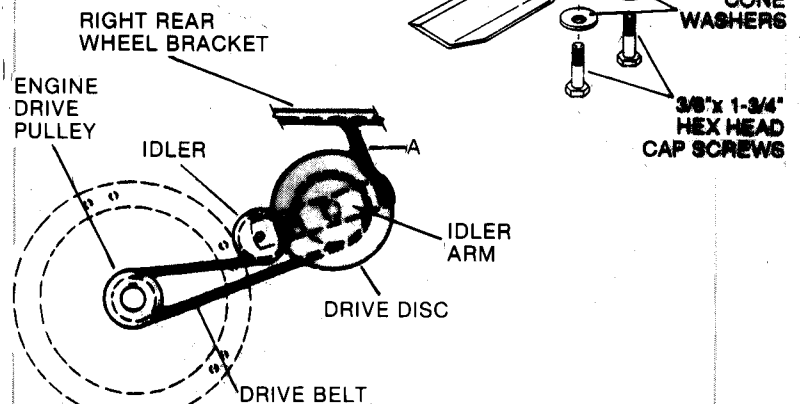

FIG. 17 -IDLER & ENGINE BELT DETAIL

POLY-V-BELT REPLACEMENT: The driven disc assembly must be removed first. Note the arrangement of the old belt around the three pulleys before cutting and removing it. Slip the replacement belt over the end of hex-shaft and onto pulley (A). Then work it onto idler pulley (B) and twist it sideways and pull upward between the differential bracket and transmission pulley (C) and then down into the pulley's groove. Make sure the belt is in each pulley's groove! Refer to FIG. 18.

NOTE: When properly installed, the lower span of Poly-V-Belt will be ABOVE the belt guide - below pulley (A).

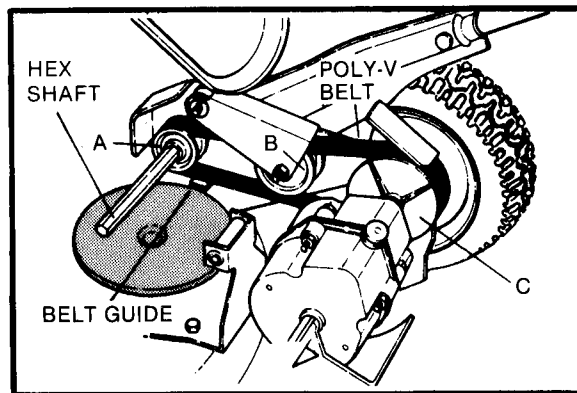

FIG. 18 -POLY-V BELT REPLACEMENT

STORAGE PROCEDURE

Refer to the engine manual for directions regarding engine storage preparations.

Prepare the mower for "end of season" storage as follows:

1. **DISCONNECT THE SPARK PLUG WIRE BEFORE ANY OTHER PREPARATIONS ARE MADE!**
2. Tape all openings closed to prevent spraying water into exhaust or air intakes during washing.
3. Turn the mower on its **LEFT** side and thoroughly clean the underside of the deck. Scrape away any accumulation of grass with a putty knife and/or wire brush. Then use a hose to wash down the underside of deck and allow to dry. Clean all external surfaces of mower and allow to dry.
4. Lubricate all exposed metal with a light coating of oil to prevent corrosion.
5. Empty the grass bag to prevent decay of debris and formation of mold while in storage. The grass bag may be washed in detergent, but allow it to dry thoroughly!
6. Store the mower in a shed or other dry area, protected from weather.
7. Handles may be tilted forward for storage by loosening knobs (21). Remove the grass bag and adaptor and then loosen knobs (21). Carefully tilt the handles forward, flexing control cables so they are not damaged. (Refer to FIG. 19).

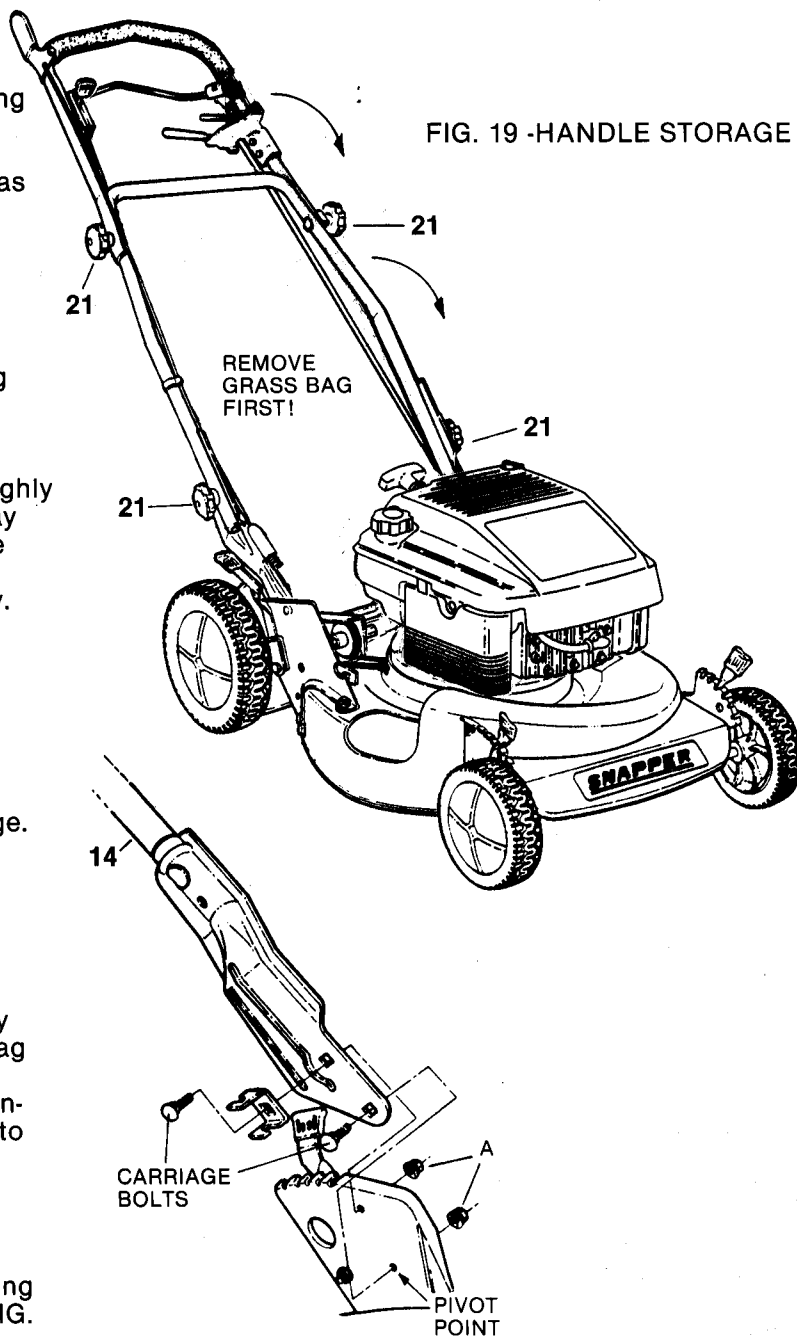

FIG. 19 -HANDLE STORAGE

HANDLE HEIGHT ADJUSTMENT

To raise or lower handle (14), loosen the adjusting locknuts (A) on both sides of handle shown in FIG. 20. Re-set handle to desired position and re-tighten the locknuts.

FIG. 20 -HEIGHT ADJUSTMENT

HUBCAP REMOVAL/INSTALLATION- ON PLASTIC WHEEL

To remove the hubcap, slip a small *flat* blade screwdriver under the hubcap lip and gently pry the hubcap from the wheel hub.

Reinstall the hubcap by aligning the four ribs with the corresponding notches in the wheel hub and then press the hubcap into place.

WHEEL COVER REMOVAL/INSTALLATION- ON STEEL WHEELS

To remove the wheel cover, hold the tire with one hand while rotating the wheel cover to the **RIGHT** (clockwise) with the other hand.

Reinstall the wheel cover by inserting each of the four prongs (on back of the cover) into the widest area of each tapered slot in the wheel. Rotate the cover to the **LEFT** (counter-clockwise) to lock into place.

POPULAR ACCESSORIES

Your **SNAPPER** mower is very versatile and can, with the addition of the fine accessories described below, perform various lawn care duties. See your **SNAPPER** Dealer for additional information on these popular kits and the complete line of quality **SNAPPER** products!

GRASS BAG KIT: A side discharging mower can be easily converted for bagging operations whenever desired with this kit. Specify mower model when ordering.

SIDE CHUTE KIT: SNAPPER mowers which are grass bag equipped, can be easily and quickly converted to side chute discharge units - to broadcast clippings. When it is once again desirable to bag grass clippings, they can be converted back to baggers in just a few minutes!

SNAPPERIZER KIT: This kit converts your mower into an outdoor vacuum "shredder". The mower will then broadcast "shredded" grass clippings and leaves out a side discharge chute or into a grass bag. Specify mower model when ordering.

SNAPPERIZER

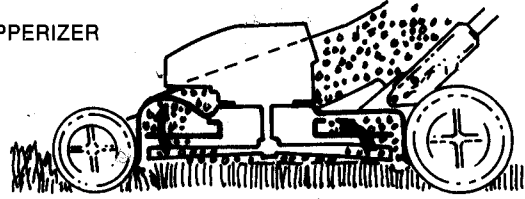

THATCHERIZER KIT: To prevent harmful "thatch" from occurring due to excessive accumulation of clippings, it is recommended that the lawn be dethatched periodically. The debris may then be vacuumed into the grass. The kit fits all 21" models.

THATCHERIZER

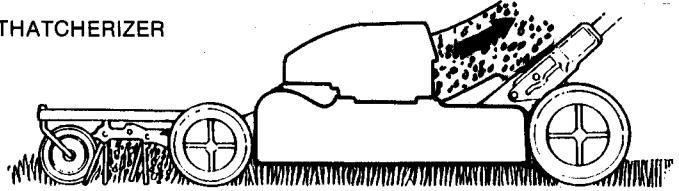

SNAPPER TOTAL PROTECTION

FULL TWO-YEAR WARRANTY - NON-COMMERCIAL USERS -

FOR TWO YEARS FROM THE ORIGINAL PURCHASE DATE OF THIS PRODUCT FOR YOUR NON-COMMERCIAL USE, SNAPPER POWER EQUIPMENT, THROUGH A SNAPPER DEALER, WILL REPAIR THE PRODUCT FREE OF CHARGE, IF IT DOES NOT WORK FOR ANY REASON.

RETURN THE PRODUCT TO A SNAPPER DEALER FOR REPAIR UNDER THIS WARRANTY.

YOU PROVIDE THE USUAL MAINTENANCE AS SPECIFIED IN THE OWNER/OPERATOR MANUALS.

THERE IS NO OTHER EXPRESS WARRANTY.

LIABILITY FOR INCIDENTAL AND CONSEQUENTIAL DAMAGES ARE EXCLUDED. SOME STATES DO NOT ALLOW THE EXCLUSION OF INCIDENTAL OR CONSEQUENTIAL DAMAGES, SO THIS EXCLUSION MAY NOT APPLY TO YOU.

THIS WARRANTY GIVES YOU SPECIFIC LEGAL RIGHTS, AND YOU MAY ALSO HAVE OTHER LEGAL RIGHTS WHICH VARY FROM STATE TO STATE AND COUNTRY TO COUNTRY.

LIMITED WARRANTY - COMMERCIAL USERS -

FOR NINETY (90) DAYS FROM THE ORIGINAL PURCHASE DATE OF THIS PRODUCT FOR YOUR COMMERCIAL USE, SNAPPER POWER EQUIPMENT, THROUGH AN AUTHORIZED SNAPPER DEALER, WILL REPAIR THE PRODUCT FREE OF CHARGE, IF IT IS FOUND TO BE DEFECTIVE IN MATERIAL OR WORKMANSHIP.

RETURN THE PRODUCT TO A SNAPPER DEALER FOR REPAIR UNDER THIS WARRANTY.

YOU PROVIDE THE USUAL MAINTENANCE AS SPECIFIED IN THE OWNER/OPERATOR MANUALS.

THERE IS NO OTHER EXPRESS WARRANTY.

IMPLIED WARRANTIES, INCLUDING THOSE OF MERCHANTABILITY AND FITNESS FOR A PARTICULAR PURPOSE, ARE LIMITED TO NINETY (90) DAYS FROM THE ORIGINAL PURCHASE DATE. SOME STATES DO NOT ALLOW LIMITATIONS ON HOW LONG AN IMPLIED WARRANTY LASTS, SO THE ABOVE LIMITATION MAY NOT APPLY TO YOU.

LIABILITY FOR INCIDENTAL AND CONSEQUENTIAL DAMAGES ARE EXCLUDED. SOME STATES DO NOT ALLOW THE EXCLUSION OR LIMITATION OF INCIDENTAL OR CONSEQUENTIAL DAMAGES, SO THE ABOVE EXCLUSION MAY NOT APPLY TO YOU.

THIS WARRANTY GIVES YOU SPECIFIC LEGAL RIGHTS, AND YOU MAY ALSO HAVE OTHER LEGAL RIGHTS WHICH VARY FROM STATE TO STATE AND COUNTRY TO COUNTRY.

PLEASE COMPLETE THE ATTACHED SNAPPER PRODUCT REGISTRATION CARD AND PROMPTLY MAIL IT TO SNAPPER POWER EQUIPMENT, McDONOUGH, GEORGIA 30253.

SNAPPER POWER EQUIPMENT

McDonough, GA., 30253 U.S.A.



#2-2668 (Rev. 1, 3/92)

PRINTED IN U.S.A.