

Parts Manual for
SNAPPER[®]

OUT FRONT Z-RIDER[™]
ZERO TURNING HYDRO DRIVE
KUBOTA SERIES 0

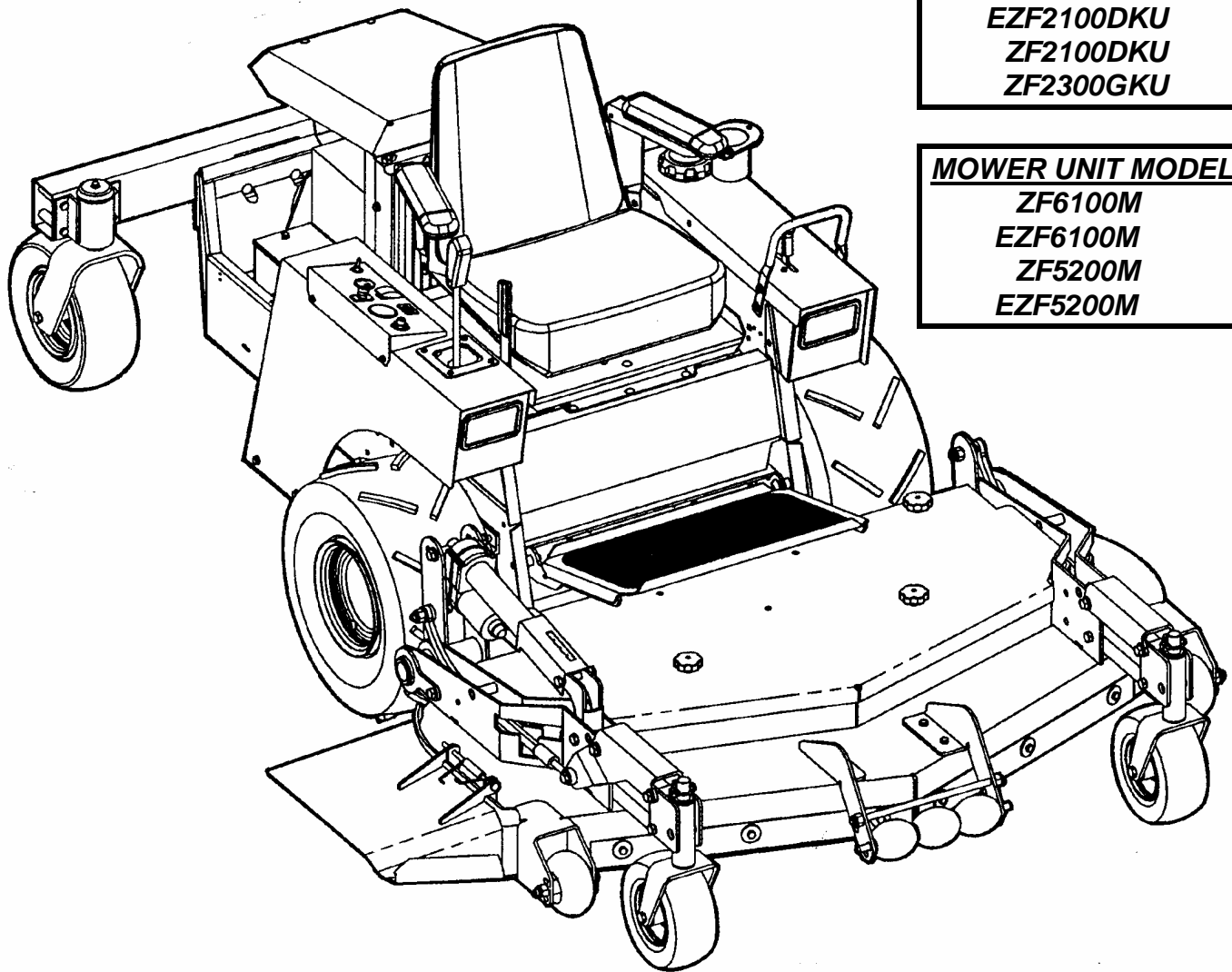

POWER UNIT MODELS

EZF2100DKU
ZF2100DKU
ZF2300GKU

MOWER UNIT MODELS

ZF6100M
EZF6100M
ZF5200M
EZF5200M

SNAPPER[®] McDonough, GA., 30253 U.S.A.

CONTENTS

<u>GROUP</u>	<u>PAGE</u>
FUEL TANK ASSEMBLY	3
ENGINE & ENGINE MOUNT ASSEMBLIES.....	4, 5
ENGINE HOOD & RADIATOR ASSEMBLIES	6, 7
TANDEM HYDRO TRANSAXLE ASSEMBLY	8, 9
DRIVE TIRE/WHEEL ASSEMBLY.....	10
FOOTREST ASSEMBLY	11
HYDRO RESERVOIR ASSEMBLY.....	12
UPPER CHASSIS AND SEAT LATCH ASSEMBLY	13
LOWER CHASSIS ASSEMBLY	14, 15
WIDE-STANCE CASTER ASSEMBLY.....	16, 17
JOYSTICK CONTROL ASSEMBLY.....	18, 19
PARKING BRAKE ASSEMBLY.....	20, 21
SEAT SUPPORT ASSEMBLY	22
FENDER ASSEMBLY	23
REAR PTO ASSEMBLY	24
TRACTION DRIVE IDLER ASSEMBLY	25
FRONT DRIVE SHAFT ASSEMBLY	26, 27
DECK DRIVE SHAFT ASSEMBLY.....	28, 29
SEAT ASSEMBLY (5-4117).....	30, 31
52" MOWER DECK ASSEMBLY	32-35
61" MOWER DECK ASSEMBLY	36-39
52" & 61" DECK IDLER ASSEMBLIES	40, 41
CUTTER HOUSING ASSEMBLY	42, 43
DECALS	44-47
ELECTRICAL COMPONENTS (except wiring)	48, 49
WIRING COMPONENTS	50, 52
WIRING SCHEMATICS.....	53, 55

FUEL TANK ASSEMBLY

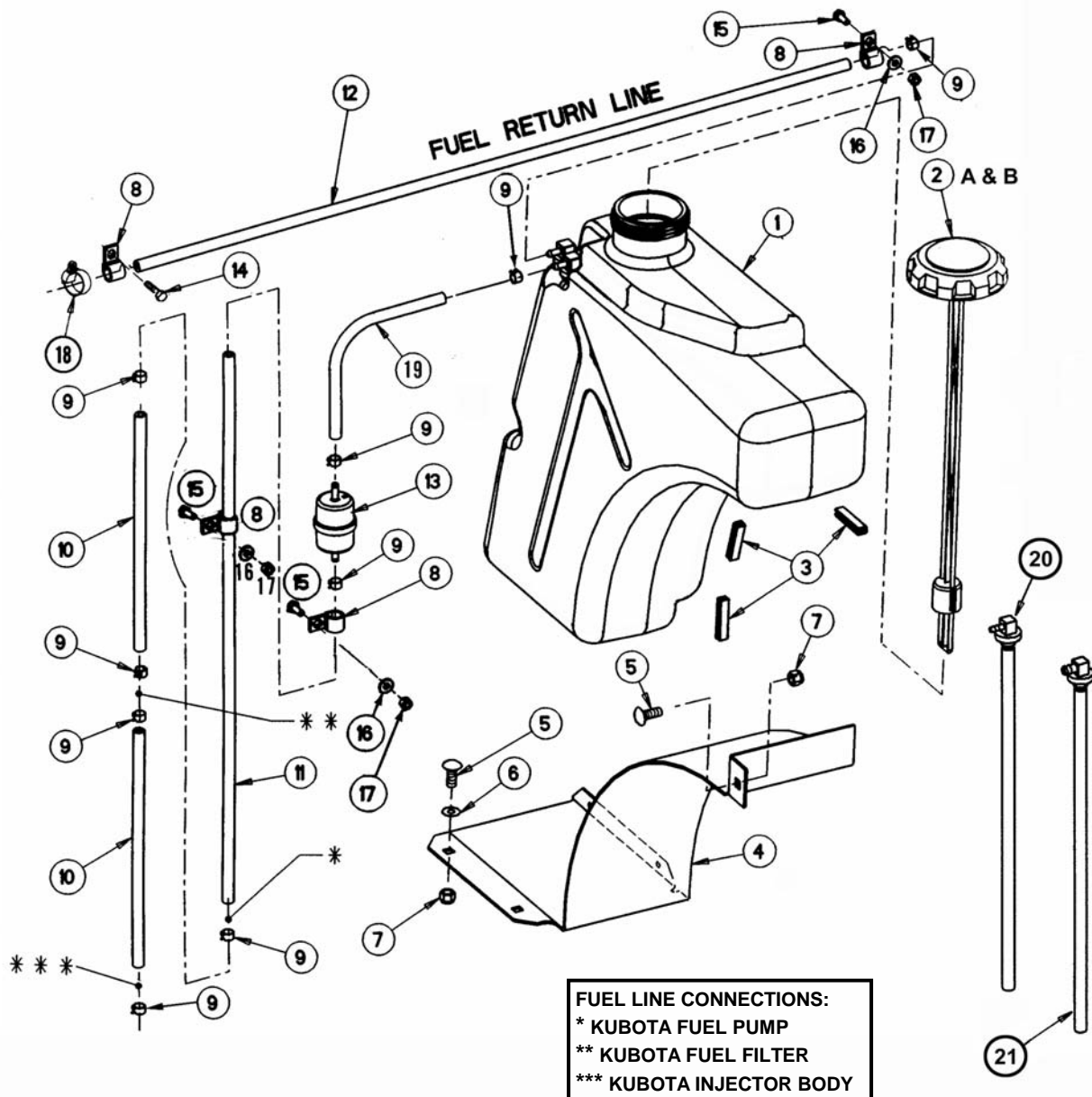

ITEM	PART NO.	DESCRIPTION	ITEM	PART NO.	DESCRIPTION
1	5-4626	TANK, Fuel (Incl.2A, 20 & 21)	11	4-6347	HOSE, Fuel (8mm x 28")
--	5-8017	TANK, Fuel (Incl. 2B & 20) (23 HP Gas Engine)	12	4-6349	HOSE, Fuel (8mm x 36") (21 HP Diesel Engine)
2A	5-4654	ASSEMBLY, Cap/Gauge	13	4-6364	FILTER, Fuel, 5/16" Hose (Kohler Part No. 240 050 02) (Hayes-Dana Part No. G81)
2B	5-4119	ASSEMBLY, Cap/Gauge (23 HP Gas Engine)	14	9-1523	SCREW, 5/16-18 x 5/8" Hex Washer Self-Tap
3	2-6746	TRIM, 2 Inch (3)	15	2-7172	SCREW, 1/4-20 x 5/8" Hex Head Cap, Grade 5 (3)
4	3-5504	BRACKET, Fuel Tank Support	16	9-1294	WASHER, 1/4" Flat (3)
5	9-1640	BOLT, Square Neck Carriage, Grade 5 (3)	17	9-1603	NUT, 1/4-20 Hex Nyloc (3)
6	1-3847	RETAINER, 3/8" Bolt (2)	18	9-1958	CLAMP, Hose 3/8" (2)
7	9-1299	NUT, 3/8-16 Hex Nyloc (3)	19	4-6348	HOSE, Fuel (6-1/2")
8	9-1959	HARNESS CLIP, 3/8" (2)	20	5-7692	FUEL PICKUP (5/16")
9	9-1957	CLAMP, 9/16" Hose (8)	21	5-7693	FUEL PICKUP (5/32")
10	4-6346	HOSE, Fuel (8mm x 12") (2)			

ENGINE & ENGINE MOUNT ASSEMBLIES

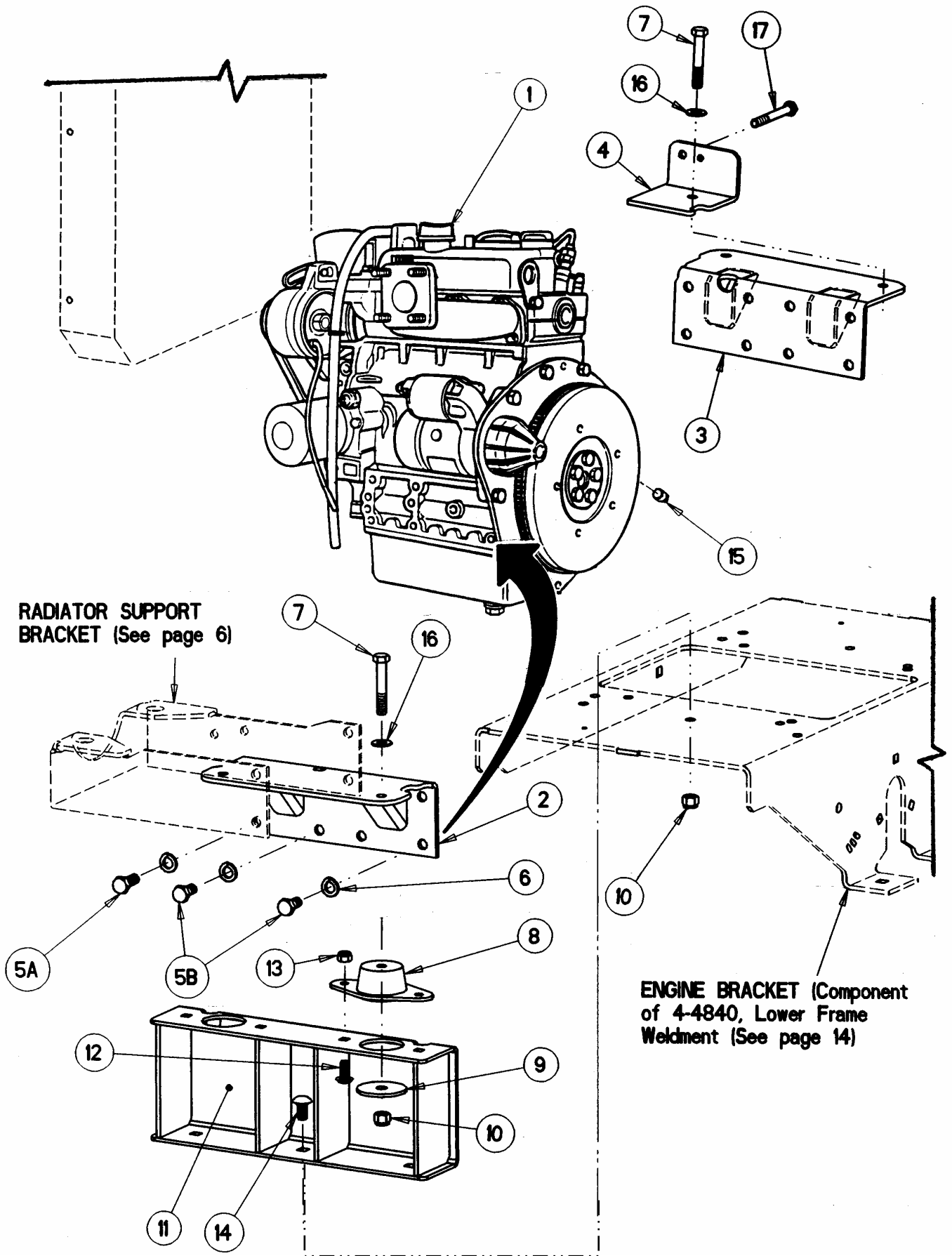

ENGINE & ENGINE MOUNT ASSEMBLIES

ITEM	PART NO.	DESCRIPTION
1	4-5147	ENGINE, 21HP Kubota Diesel (Kubota Model D722B-I/D 722EB-1)
--	4-7214	ENGINE, 23HP Kubota Gas (Kubota Model WG750ELP-1)
2	4-5351	MOUNT, Engine, Left Hand
3	4-5352	MOUNT, Engine, Right Hand
4	4-1826	BRACKET, Fuel Filter
5A	9-1935	SCREW, M10-1.25 x 25mm (4)
5B	9-1934	SCREW, M10-1.25 x 20mm (8)
6	9-1301	WASHER, 7/16" Split Lock (12)
7	9-1501	SCREW, 3/8-16 x 2-1/2" Hex Head Cap, Grade 5 (4)
8	4-5263	MOUNT, Isolator (4)
9	4-5265	WASHER, Snubbing (4)
10	9-1299	NUT, 3/8-16 Nyloc (10)
11	4-5353	SUPPORT, Lower Channel (2)
12	9-1508	BOLT, 5/16-18 x 3/4" Short Neck Carriage, Grade 5 (8)
13	9-1298	NUT, 5/16-18 Nyloc (8)
14	2-7181	BOLT, 3/8-16 x 1-1/4" Short Neck Carriage, Grade 5 (6)
15	2-9039	PLUG, 1/4 Pipe
16	9-1514	WASHER, 3/8" Flat (4)
17	9-1944	SCREW, 5/16-18 x 2-3/4" Hex Head Cap, Grade 5

**NOTE: FOR ALL PARTS NOT REFERENCED BY A SNAPPER PART NUMBER:
SEE YOUR AUTHORIZED KUBOTA ENGINE DEALER.**

ENGINE HOOD & RADIATOR ASSEMBLIES

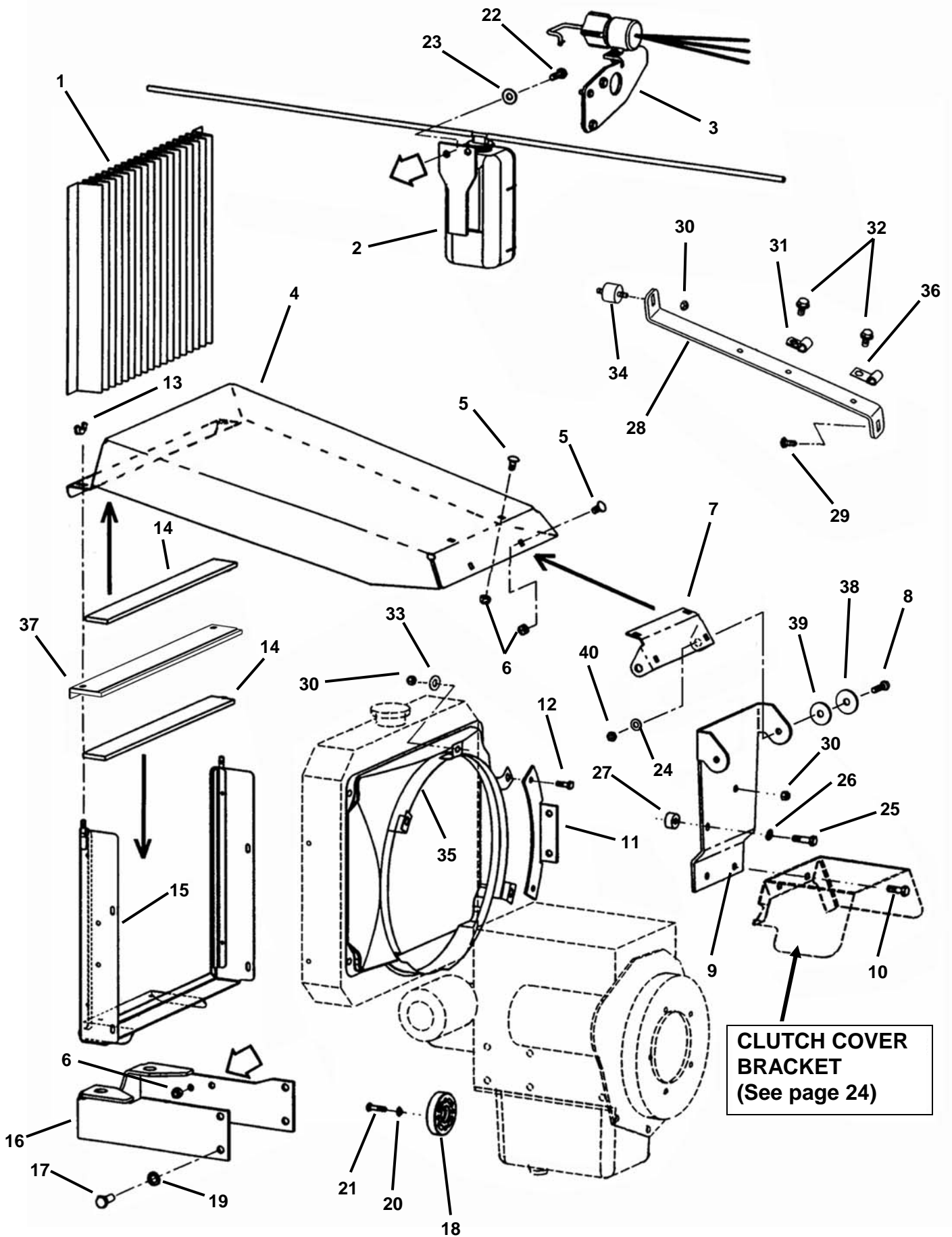

ENGINE HOOD & RADIATOR ASSEMBLIES

ITEM	PART NO.	DESCRIPTION
1	4-5294	SCREEN, Radiator
2	-----	TANK, Coolant Recovery (Includes Tank, Bracket and Hoses) (Kubota part no. 19059-72091)
3	-----	KIT, Solenoid (Includes Solenoid, Bracket and Mounting Hardware) (Kubota kit no. 1A)
4	4-5289	WELDMENT, Engine Hood
5	9-1918	BOLT, 5/16-18 x 5/8" Short Neck Carriage, Grade 5 (4)
6	9-1298	NUT, 5/16-18 Hex Nyloc (5)
7	7-3478	BRACKET, Hood Hinge
8	9-1527	SCREW, 5/16-18 x 1-1/4" Hex Head Cap, Grade 5 (2)
9	4-5290	SUPPORT, Engine Hood
10	9-1933	SCREW, M8-1.25 x 25mm Hex Head Cap (2)
11	4-5291	BRACKET, Air Cleaner
12	9-1931	SCREW, M6-1.00 x 20mm Hex Head Cap (2)
13	9-0997	WINGNUT, 1/4-20 Locking (2)
14	4-5297	STRIP, Sponge Rubber (2)
15	4-5296	WELDMENT, Radiator Screen Support
16	4-5329	BRACKET, Radiator Support
17	9-1935	SCREW, M10-1.25 x 25mm Hex head Cap (4)
18	4-5316	SPACER, Fan
19	9-1301	WASHER, 7/16 Split Lock (4)
20	2-7223	WASHER, 1/4" Split Lock (4)
21	9-1932	SCREW, M6-1.00 x 25mm Hex Head Cap (4)
22	2-7168	SCREW, 5/16-18 x 1" Hex Head Cap, Grade 5 (2)
23	9-1528	WASHER, 3/8" Flat (2)
24	9-1088	WASHER, 5/16" Flat (2)
25	9-1924	SCREW, M8-1.25 x 30mm Hex Head Cap (2)
26	9-1315	WASHER, .32 I.D. Split Lock (3)
27	4-1991	SPACER, .33 I.D. x .75 O.D. x .459 Long
28	4-1993	BRACE, Radiator
29	9-1776	BOLT, 1/4-20 x 3/4" Square Neck Carriage, Grade5
30	9-1705	NUT, 1/4-20 Hex Top Lock (3)
31	9-1959	HARNESS CLIP, 3/8"
32	9-1523	SCREW, 5/16-18 x 5/8" Hex Washer Face Self-Tap (2)
33	9-1294	WASHER, 1/4" Flat
34	4-6227	ISOLATOR, Stud Mount
35	4-5318	SHROUD, Kubota Diesel Radiator
36	3-5638	J-CLIP, 3/8"
37	5-8878	ASSEMBLY, Radiator Seal (Incl. adhesive weather strip, Snapper 7-3350)

NOTE: See page 5 for Engine Components.

TANDEM HYDRO TRANSAXLE ASSEMBLY

NOTE:
HYDRO TRANSAXLE MAINTENANCE
SHOULD ONLY BE PERFORMED BY
AN AUTHORISED SNAPPER DEALER.

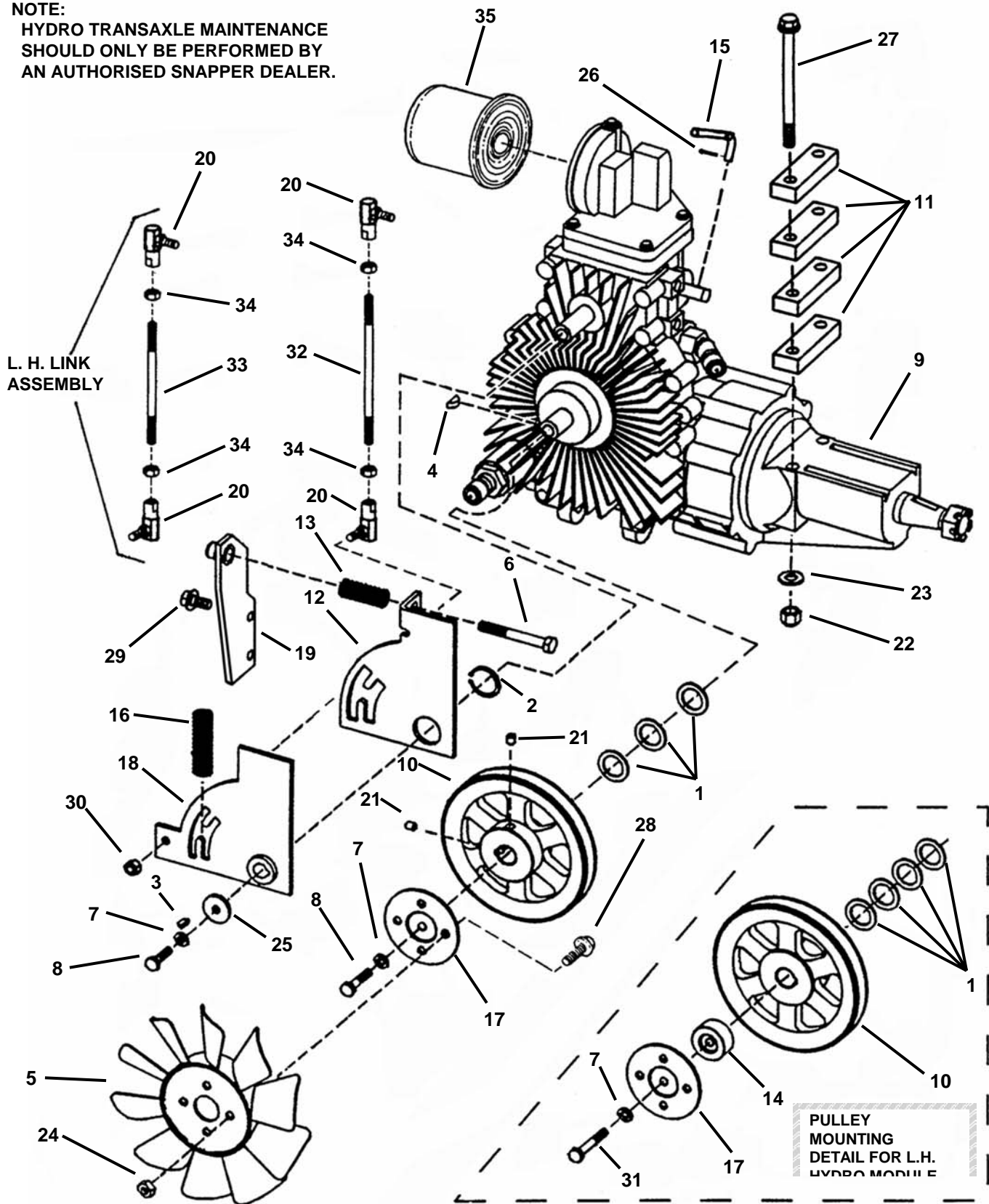

TANDEM HYDRO TRANSAXLE ASSEMBLY

ITEM	PART NO.	DESCRIPTION
1	1-0935	WASHER, 3/4 I.D. x 1-1/8" O.D. Flat (7)
2	1-2709	RETAINING RING, 1" External (2)
3	1-4264	WOODRUFF KEY, #404 (2)
4	1-5894	WOODRUFF KEY, #605 (2)
5	1-8978	FAN, 10 Blade 7" Dia. (2)
6	2-7175	BOLT, 5/16-18 x 2-1/2" Hex Head (2)
7	2-7223	WASHER, 1/4 Split Lock (4)
8	9-1814	SCREW, 1/4-20 x 1-1/4", Hex Head Cap (3)
9	5-8190	ASSEMBLY, Transaxle 771B (R.H.) Side (shown)
--	5-8189	ASSEMBLY, Transaxle 771A (L.H.) Side
10	3-5547	PULLEY, Transmission Input (2)
11	7-2017	SPACER, Eaton Transaxle (8)
12	3-5910	PLATE, Neutral Adjust (2)
13	3-5915	SPRING, Neutral Return Adjust (2)
14	3-5923	SPACER/ADAPTER, Fan
15	3-5925	ROD, Roll Release (2)
16	3-5927	SPRING, Neutral Return (2)
17	4-2612	SPACER, Fan (Weldment) (2)
18	4-2639	CAM, Neutral Return (Weldment) (2)
19	5-9441	PLATE, Neutral Return (Weldment) (2)
20	1-5753	BALL-JOINT (4)
21	9-1802	SET SCREW, 5/16-18 x 5/8" Hex Recess (4)
22	9-1299	NUT, 3/8-16, Hex Nyloc (4)
23	9-1514	WASHER, 13/32 I.D. x 13/16 O.D. Flat (4)
24	9-1603	NUT, 1/4-20 Hex Nyloc (8)
25	9-1627	WASHER, 1/4 I.D. x 1" O.D. (2)
26	9-1629	COTTER-PIN, 1/16 x 1/2" (2)
27	9-1786	BOLT, 3/8-16 x 4-3/4" Grade 5 (4)
28	9-1787	SCREW, 1/4-20 x 5/8", Hex Flange Lock, Grade 5 (8)
29	9-1811	BOLT, 5/16-18 x 5/8", Hex Flange Lock (4)
30	9-1812	NUT, 1/4-28, Hex Nyloc (4)
31	9-0505	SCREW, 1/4-20 x 2", Hex Head Cap, Grade 5
32	3-5914	ROD, Threaded 1/4-28 x 5-3/8"
33	3-5916	ROD, Threaded 1/4-28 x 4-3/8"
34	9-1605	NUT, 1/4-28 Hex, Grade 5 or B (4)
35	4-2715	FILTER, Oil (EATON No. 103144)

DRIVE TIRE/WHEEL ASSEMBLY

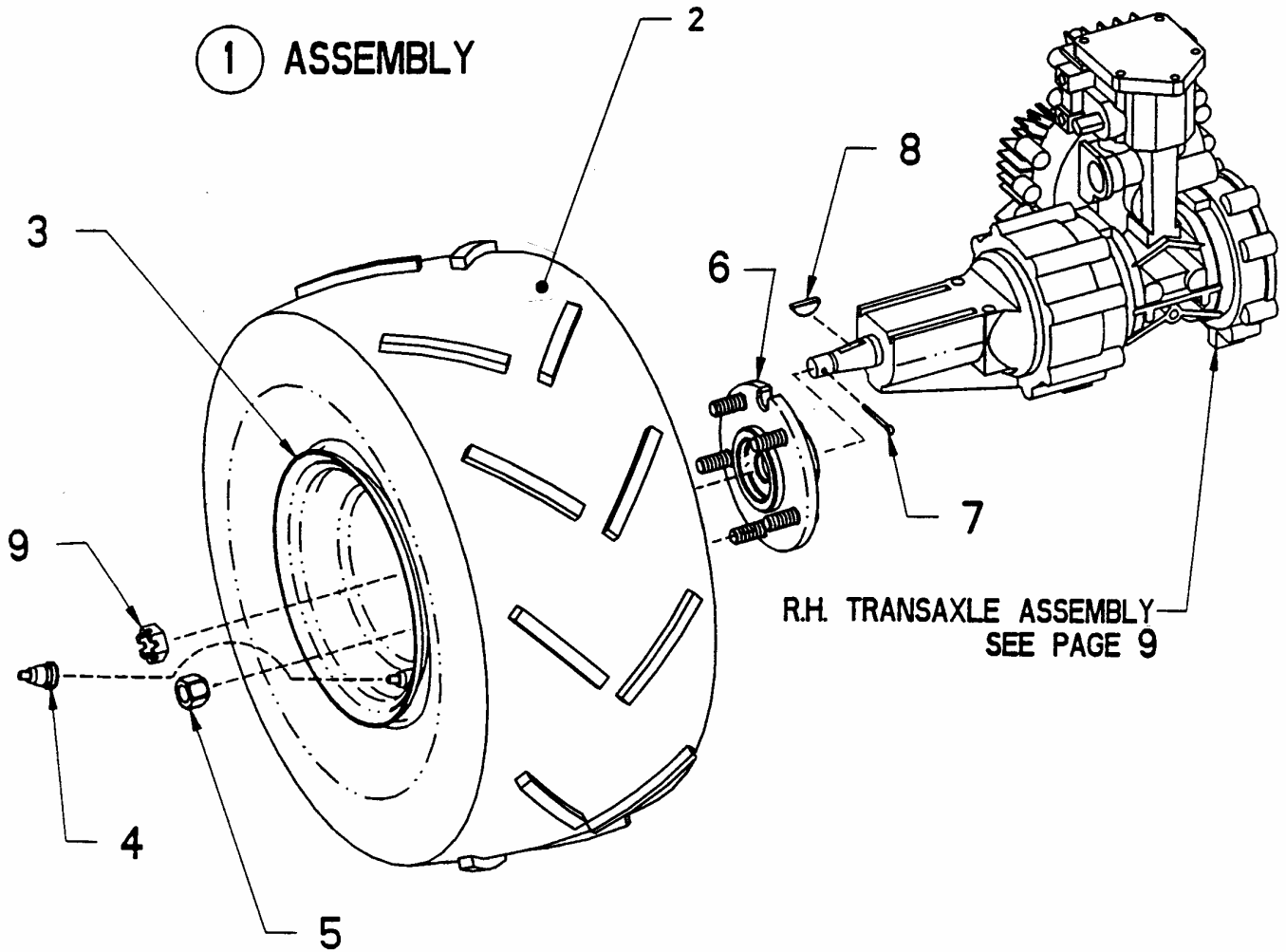

ITEM	PART NO.	DESCRIPTION
1	5-4509*	ASSEMBLY, Rear Tire & Rim L.H. (Not Shown)
--	5-4510*	ASSEMBLY, Rear Tire & Rim R.H. (Shown)
2	4-4707	TIRE, 21 x 11.00-8 4 ply "All Terrain"
3	5-4111	RIM, 8" Dia. X 7-3/4"
4	1-2234	VALVE, Air
5	2-7192	NUT, 1/2-20 Lug (10)
6	5-4461	ASSEMBLY, Wheel Hub (2)
7	9-1793	PIN, Cotter, 9/64 x 1-1/2" (2)
8	9-1778	KEY, #808 Woodruff (2)
9	9-1828	NUT, 3/4-20 Slotted Hex (2)

*(Includes items 2, 3 & 4.)

FOOTREST ASSEMBLY

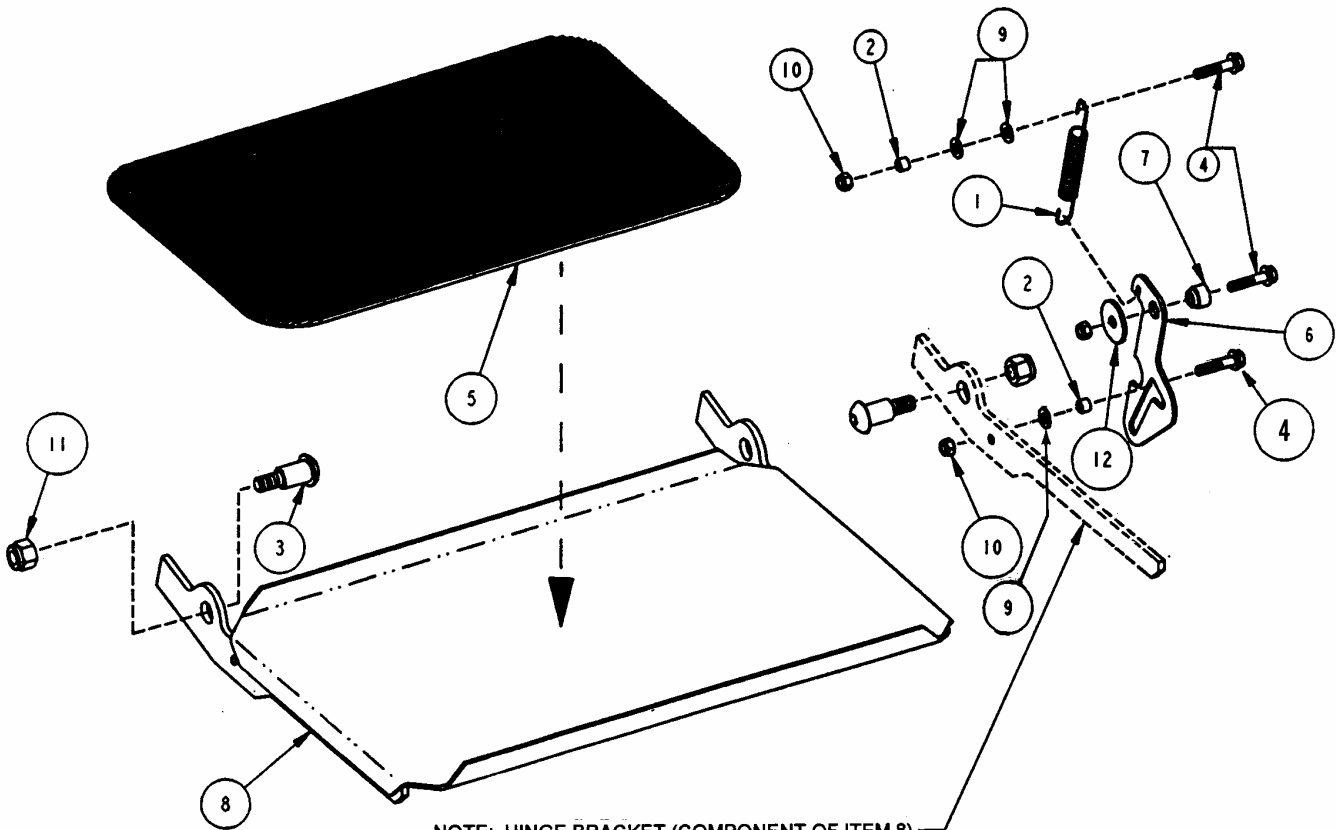

NOTE: HINGE BRACKET (COMPONENT OF ITEM 8)
SHOWN "DETACHED" FOR CLARITY
OF ASSEMBLY

ITEM	PART NO.	DESCRIPTION
1	2-2696	SPRING
2	2-8810	BUSHING, 5/16 I.D. x 7/16 O.D. x 3/16 (2)
3	3-5849	BOLT, 1/2-13, 3/4 Dia. X 1-1/16 Shoulder (2)
4	9-1602	BOLT, 5/16-18 x 1-1/2 Hex Flange Lock, Grade 5 (3)
5	3-5855	FOOT PAD, Rubber
6	3-5978	PLATE, Footrest Latch
7	3-5979	SPACER, Shoulder (Latch)
8	4-2630	FOOTREST (Weldment)
9	9-1296	WASHER, 11/32 I.D. x 11/16 O.D. x 1/16" Flat (3)
10	9-1298	NUT, 5/16-18 Nyloc (3)
11	9-1894	NUT, 1/2-13 Hex Center Lock, Grade 5 (2)
12	9-1331	WASHER, 13/32 I.D. x 1-1/2 O.D. x 1/8" Flat

HYDRO RESERVOIR ASSEMBLY

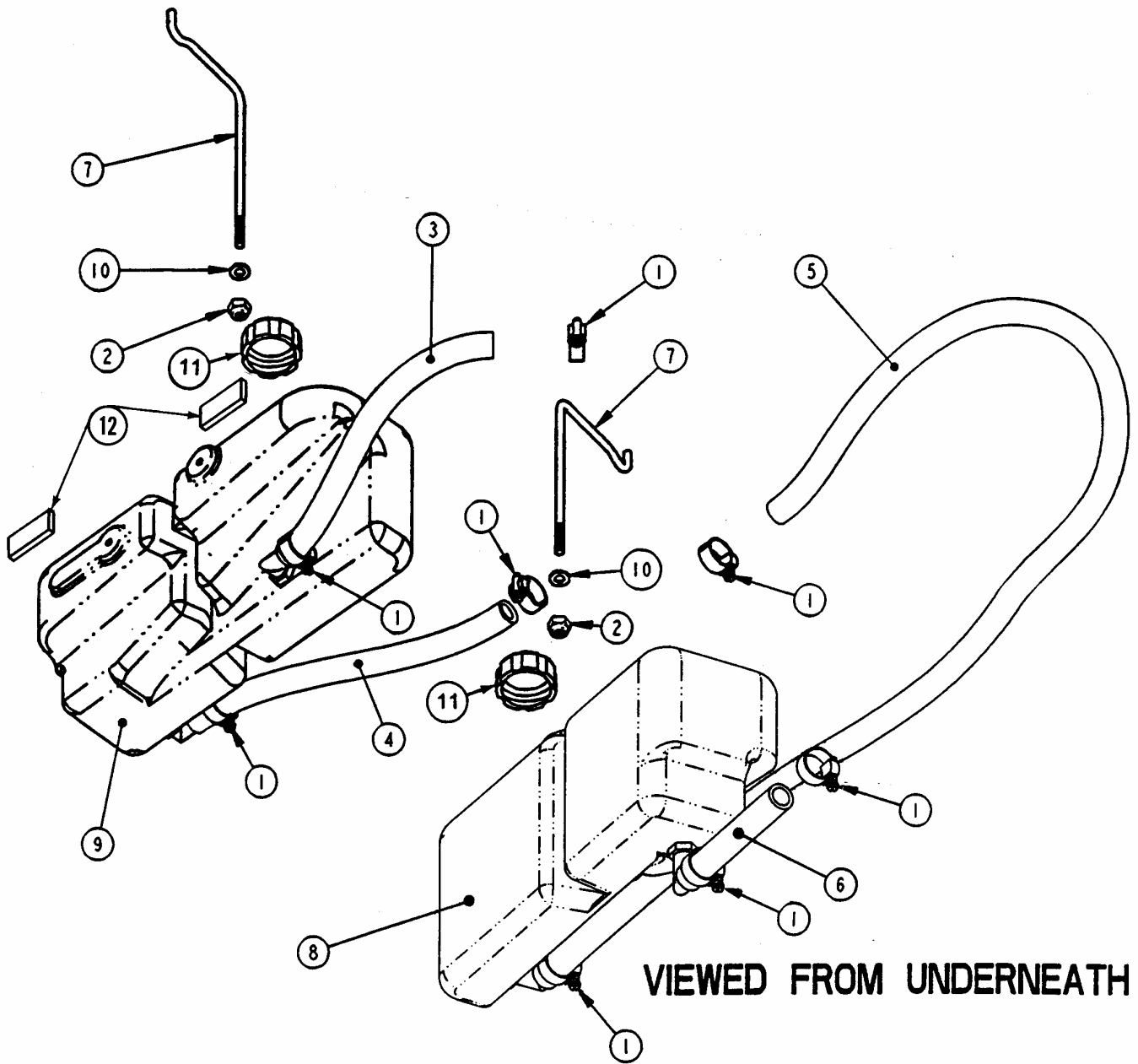

ITEM	PART NO.	DESCRIPTION
1	1-6130	CLAMP, Hose 13/16" (8)
2	9-1298	NUT, 5/16-18 Nyloc (2)
3	3-5514	HOSE, Rubber R.H. Front (13-1/2")
4	3-5515	HOSE, Rubber R.H. Back (16")
5	4-1834	HOSE, Rubber L.H. Front (34")
6	4-1833	HOSE, Rubber L.H. Back (6")
7	3-5639	BRACKET, Reservoir (2)
8	5-4703	RESERVOIR, L.H. Hydro (includes cap, item 11)
9	5-4103	RESERVOIR, R.H. Hydro (includes cap, item 11)
10	9-1296	WASHER, 11/32" I.D. x 11/16" O.D. (2)
11	3-5512	CAP, Reservoir
12	7-7345	PAD, Tank (4)

UPPER CHASSIS AND SEAT LATCH ASSEMBLY

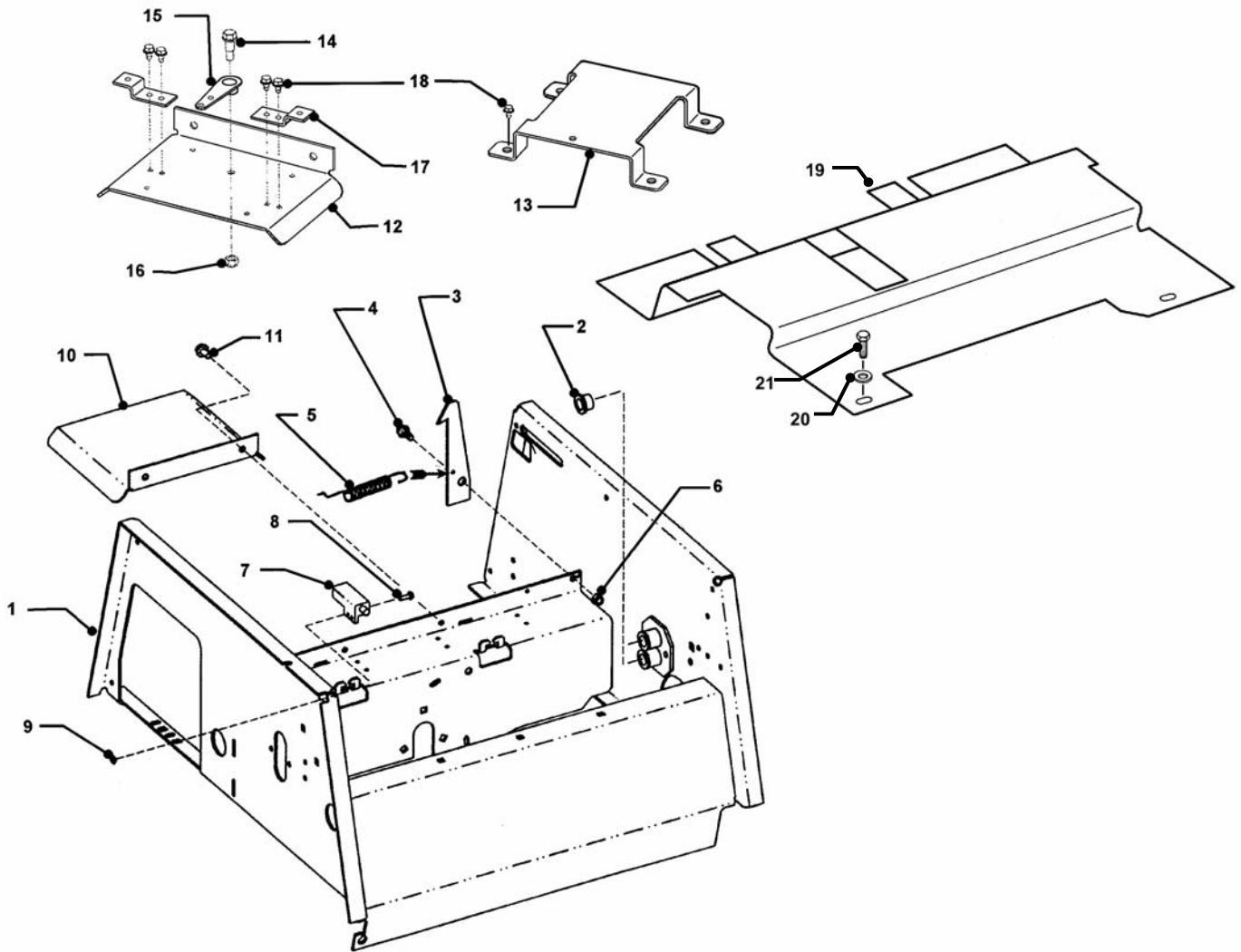

ITEM	PART NO.	DESCRIPTION	ITEM	PART NO.	DESCRIPTION
1	4-2601	UPPER CHASSIS	11	9-1523	SCREW, 5/16-18 x 5/8" Hex (2)
--	5-8674	UPPER CHASSIS (European Model)	12	7-1986	GUARD, Driveshaft (Model ZF2300GKU)
2	1-3874	BUSHING, 5/8" (2)	13	7-1992	COVER, Cable
3	3-5993	LATCH, Seat Support	14	1-4664	BOLT, 5/16-18 Shoulder
4	9-1800	BOLT, 5/16-18 Shoulder	15	5-8243	LEVER, Cable Control
5	2-6292	SPRING	16	9-1298	NUT, 5/16-18 Hex Nyloc
6	9-1298	NUT, 5/16-18 Hex Nyloc	17	7-1987	BRACKET, Cable Anchor (2)
7	4-5345	SWITCH, DPDT	18	9-1084	SCREW, 1/4-20 x 3/8" Self-Tap (8)
8	9-1240	SCREW, #10-32 x 5/8" Gr. 5 (2)	19	7-2276	SHIELD, Drive (European Model)
9	9-0376	NUT, #10-32 Hex Nyloc (2)	20	9-1294	WASHER, 1/4 Flat (2)
10	4-5292	GUARD, Driveshaft (Model ZF2100DKU)	21	9-1819	SCREW, 1/4-20 x 5/8" Self-Tap (2)

LOWER CHASSIS ASSEMBLY

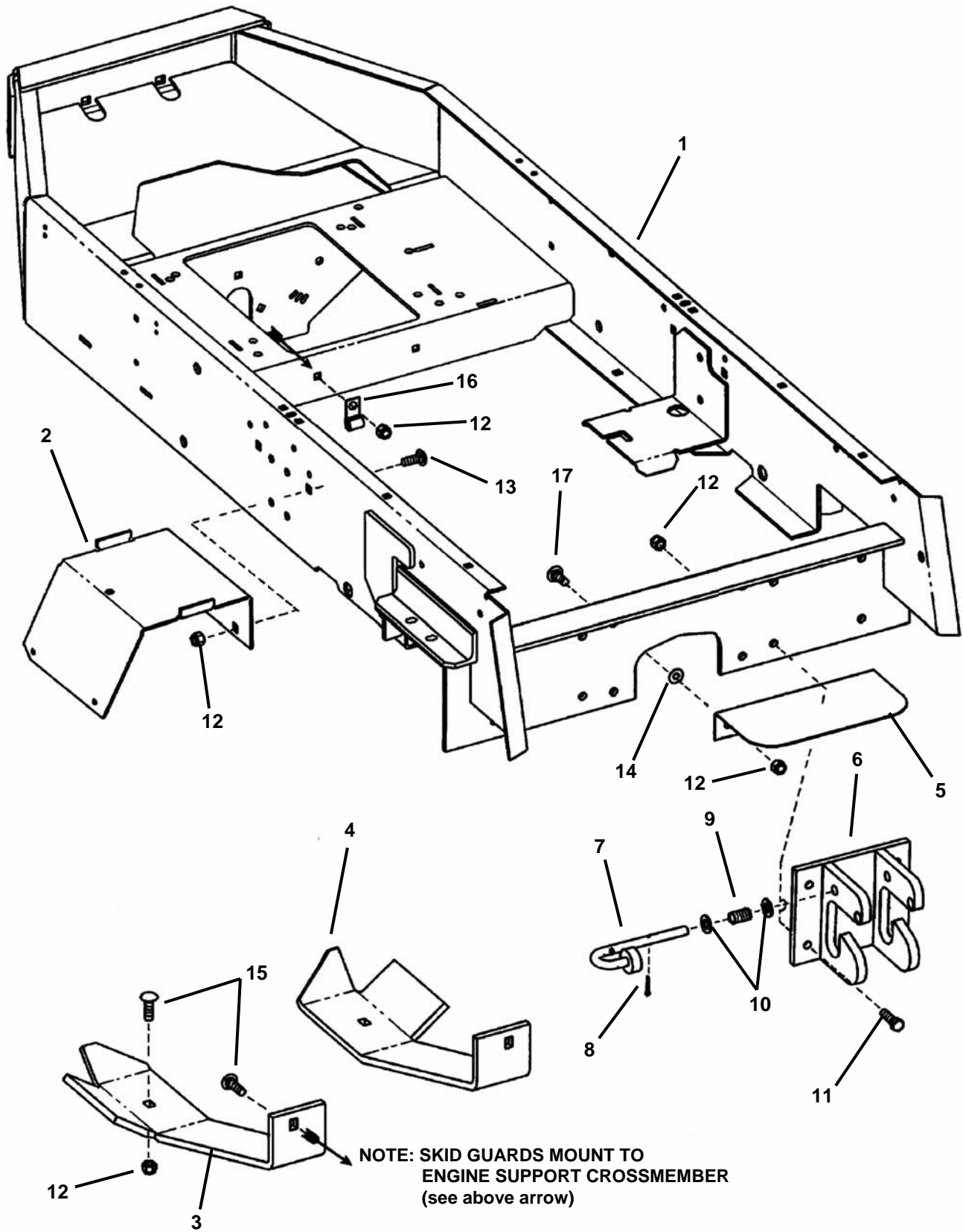

LOWER CHASSIS ASSEMBLY

ITEM	PART NO.	DESCRIPTION
1	4-4840	CHASSIS, Lower
--	5-8670	CHASSIS, Lower (Euro)
2	3-6406	BRACKET, Battery Support
3	4-5227	SKID GUARD, R.H.
4	4-5226	SKID GUARD L.H.
5	4-2777	SHIELD, Grass
6	4-2628	PLATE, Hitch (2)
7	4-2629	PIN, Hitch (2)
8	9-1598	PIN, Cotter, 1/8 x 3/4" (2)
9	1-4432	SPRING (2)
10	9-1595	WASHER, 15/32 I.D. x 15/16" O.D., Flat (4)
11	9-1328	SCREW, 3/8-16 x 1-1/4", Hex Hd. Cap, Gr. 5 (8)
12	9-1299	NUT, 3/8-16 Hex Nyloc (16)
13	9-1640	BOLT, 3/8-16 x 1" Carriage, Grade 5 (4)
14	1-3847	RETAINER, 3/8" Bolt (2)
15	9-1790	BOLT, 3/8-16 x 1-1/4", Carriage, Grade 5 (4)
16	3-5638	J-CLIP, Open Cushioned (2)
17	2-7181	BOLT, 3/8-16 x 1-1/4" Short Neck Carriage, Grade 5 (4)

WIDE-STANCE CASTER ASSEMBLY

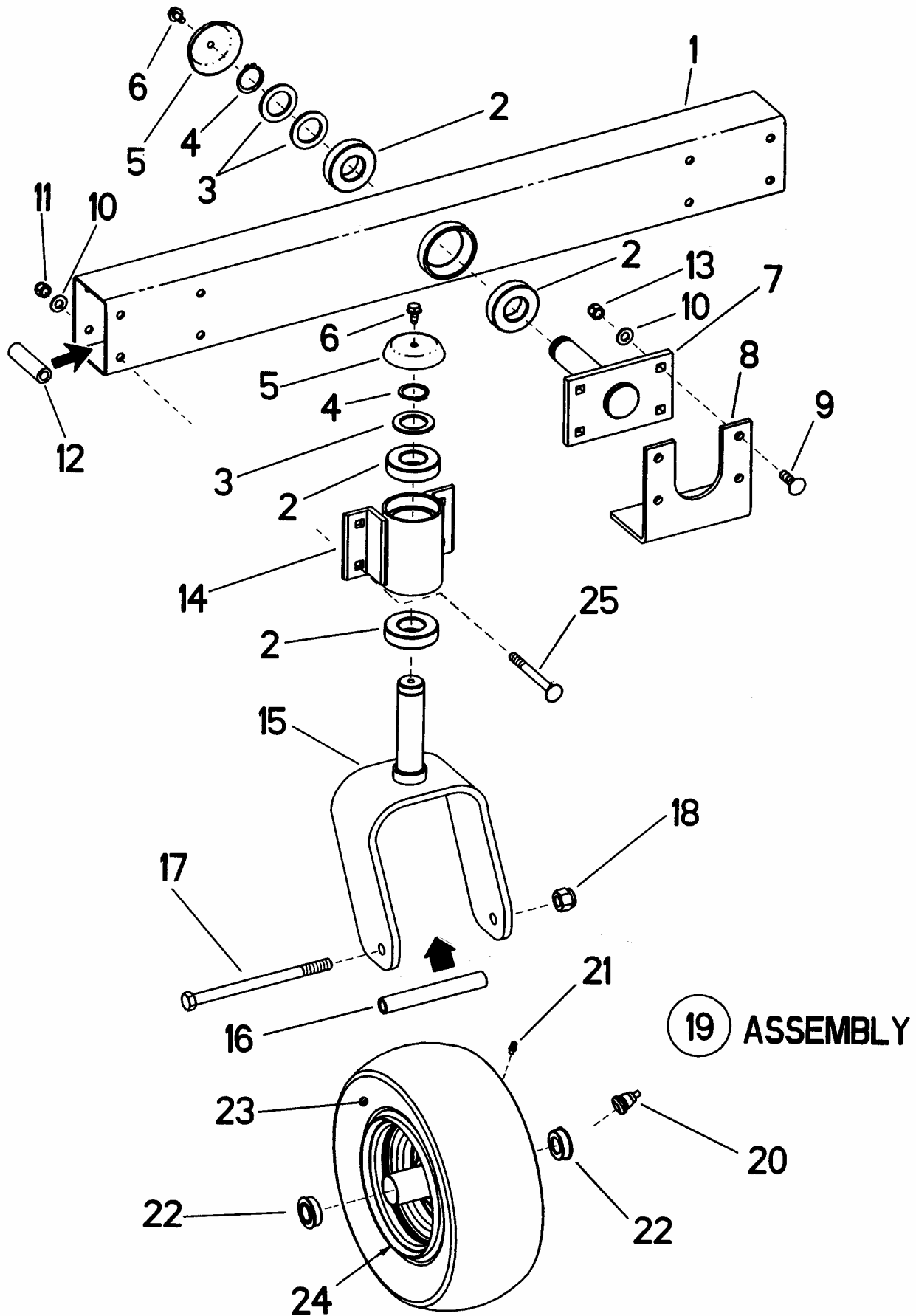

WIDE-STANCE CASTER ASSEMBLY

ITEM	PART NO.	DESCRIPTION
1	4-2961	WELDMENT, Axle
2	3-5602	BEARING, 30mm x 62mm (6)
3	9-1795	WASHER, 1-1/4 I.D. x 1-7/8" O.D. Flat (4)
4	1-0965	RING, 1-3/16 External Retaining (3)
5	3-6578	CAP, Caster Shaft (3)
6	9-0361	SCREW, 5/16-18 x 5/8" Self-Tapping (3)
7	4-5212	WELDMENT, Front Axle Pivot
8	4-2978	BRACKET, Axle Stop
9	9-1945	BOLT, 3/8-16 X 1-1/2" Short Neck Carriage, Grade 5 (4)
10	9-1514	WASHER, 3/8 Flat (12)
11	9-1299	NUT, 3/8-16 Hex Nyloc (8)
12	4-2928	TUBE, 13/32 I.D. x 3/4 O.D. x 2.70 (8)
13	9-1585	NUT, 3/8-16 Hex Center Lock, Grade B or 5 (4)
14	4-2590	WELDMENT, Caster Support (2)
15	4-2591	WELDMENT, Caster Yoke (2)
16	3-5476	SPACER, Bearing (2)
17	9-1773	SCREW, 1/2-13 x 7-1/4" Hex Head Cap, Grade 5 (2)
18	9-1325	NUT, 1/2-13 Nyloc (2)
19	5-4087	ASSEMBLY, Tire & Rim (Includes 20 thru 24) (2)
20	1-2234	VALVE, Air
21	1-2700	FITTING, Lube
22	2-8722	BEARING (2)
23	3-5474	TIRE, 13 x 5.00-6, 4 Ply
24	3-5475	RIM
25	9-1888	BOLT, 3/8-16 x 4" Square Neck Carriage, Grade 5 (8)

JOYSTICK CONTROL ASSEMBLY

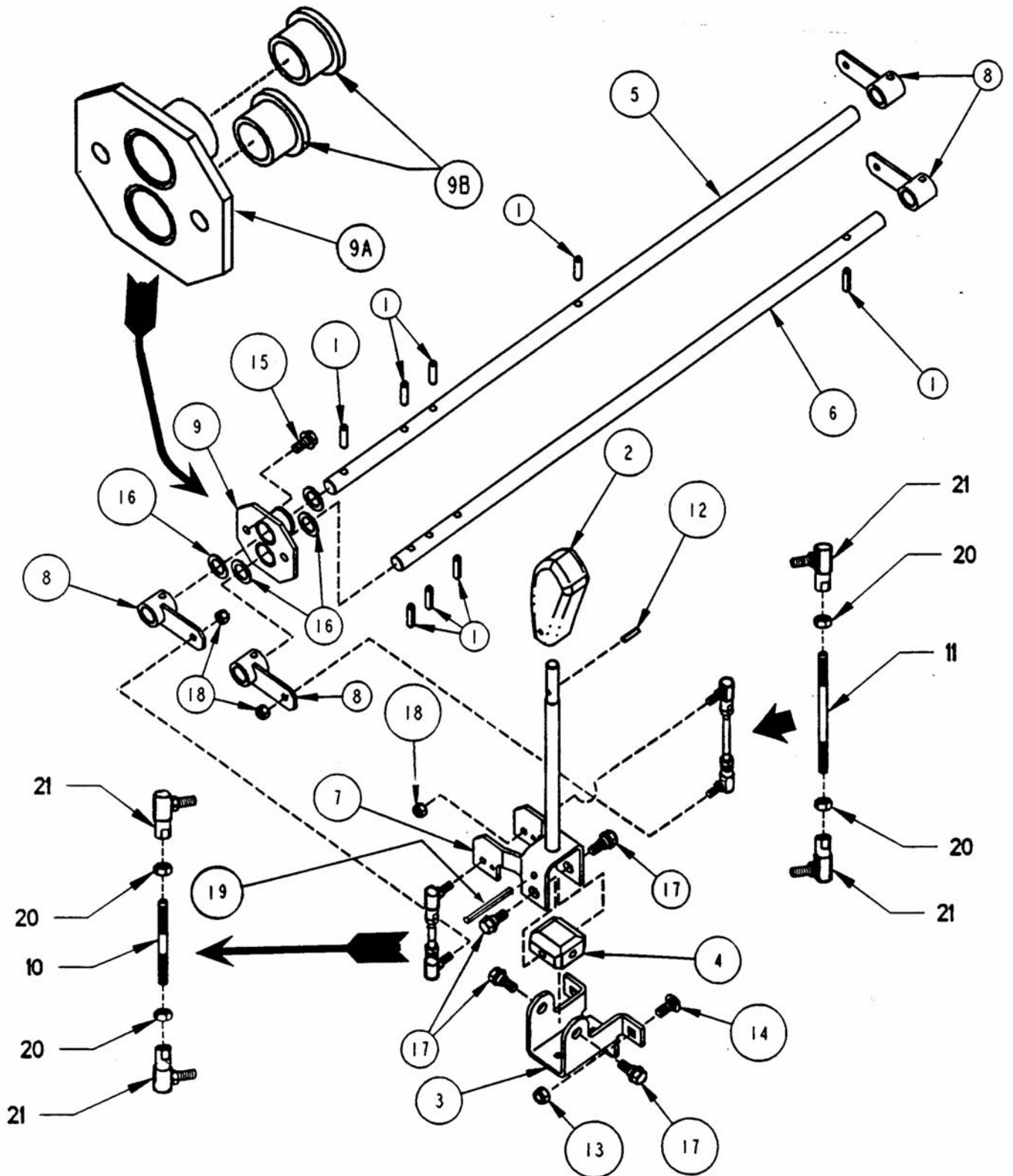

JOYSTICK CONTROL ASSEMBLY

ITEM	PART NO.	DESCRIPTION
1	1-3072	ROLL PIN, 1/4 x 1" (8)
2	2-3656	HANDLE, Plastic
3	3-5532	BRACKET, Joystick Mounting
4	3-5533	BLOCK, Pivot Joystick Control
5	3-5897	SHAFT, Upper Cross
6	3-5898	SHAFT, Lower Cross
7	4-2599	HANDLE, Joystick Control (Weldment)
8	4-2638	ARM/HUB Weldment (4)
9	5-4237	ASSEMBLY, Cross Shaft Support (includes one 9A & two 9B)
9A	4-2623	SUPPORT, Cross Shaft (Weldment)
9B	1-3874	BUSHING (2)
10	3-5908	ROD, Threaded 1/4-28 x 2.71 long
11	3-5909	ROD, Threaded 1/4-28 x 3.85 long
12	9-0844	ROLL PIN 3/16 x 3/4"
13	9-1298	NUT, 5/16-18 Hex Nyloc (3)
14	9-1508	BOLT, 5/16-18 x 3/4" Sq.Nk. Carriage, Grade 5 (3)
15	9-1523	SCREW, 5/16-18 x 5/8" Hex Washer Self-Tap (2)
16	9-1628	WASHER, 41/64 I.D. x 1" O.D. Flat (4)
17	9-1800	BOLT, 5/16-18 Shoulder (4)
18	9-1812	NUT, 1/4-28 Hex Nyloc (4)
19	9-1816	ROLL PIN, 1/4 x 2-3/4"
20	9-1605	NUT, 1/4-28 Hex, Grade 5 or B (4)
21	1-5753	BALL-JOINT (4)

PARKING BRAKE ASSEMBLY

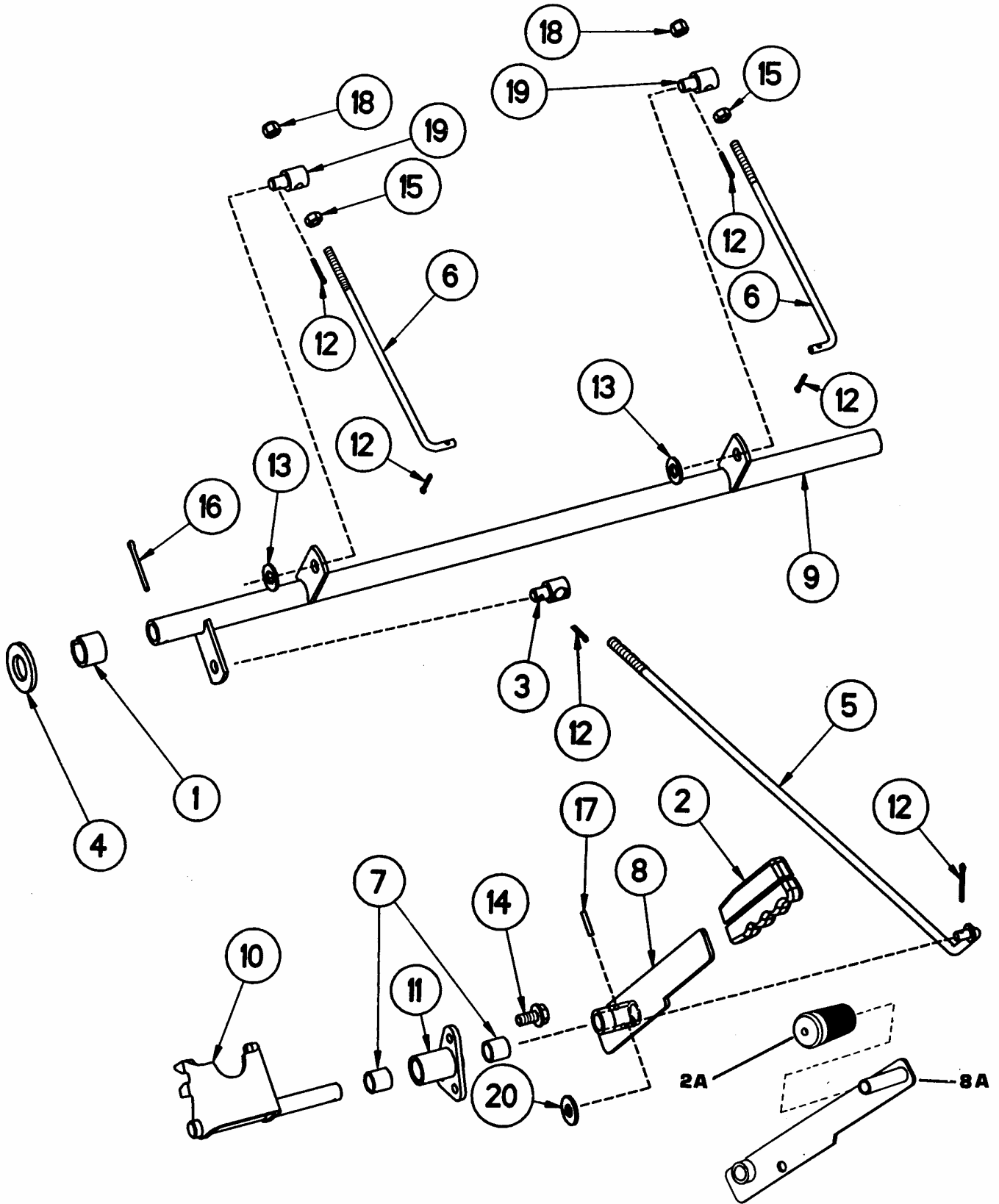

PARKING BRAKE ASSEMBLY

ITEM	PART NO.	DESCRIPTION
1	1-2068	RING, Rear Lift Arm
2	2-6420	GRIP, Flat Bar (21 HP Diesel Engine)
2A	7-2222	GRIP, Round Bar (23 HP Gas Engine)
3	4-6451	SWIVEL, Adjustable
4	3-4453	WASHER, 3/4 I.D. x 1-1/2 O.D. x 9/64" Flat
5	4-6456	ARM, Brake Lift
6	3-5888	ROD, Hydrostatic Brake (2)
7	3-6399	SLEEVE Bearing, 1/2 I.D. x 5/8 (2)
8	4-6469	ARM, Parking Brake (21 HP Diesel Engine)
8A	5-8082	ARM, Parking Brake (23 HP Gas Engine)
9	4-2635	SHAFT, Brake
10	4-2647	BRACKET, Joystick Lockout
11	4-2648	PLATE, Support
12	9-1597	COTTER PIN, 3/32 x 3/4" (6)
13	9-1514	WASHER, 13/32 I.D. x 13/16 O.D. x 5/64 Flat (3)
14	9-1523	SCREW, 5/16-18 x 5/8" Hex Washer Face Self-Tap (3)
15	9-1605	NUT, 1/4-28 Hex, Grade 5 or B (2)
16	9-1809	COTTER PIN, 1/8 x 1-1/4
17	1-4001	PIN, Roll 1/8 x 3/4"
18	9-1812	NUT, 1/4-28 Hex Nyloc (2)
19	9-1832	SWIVEL, 1/4" Smooth (2)
20	9-0692	WASHER, 3/8" I.D. x 7/8" O.D. Flat

SEAT SUPPORT ASSEMBLY

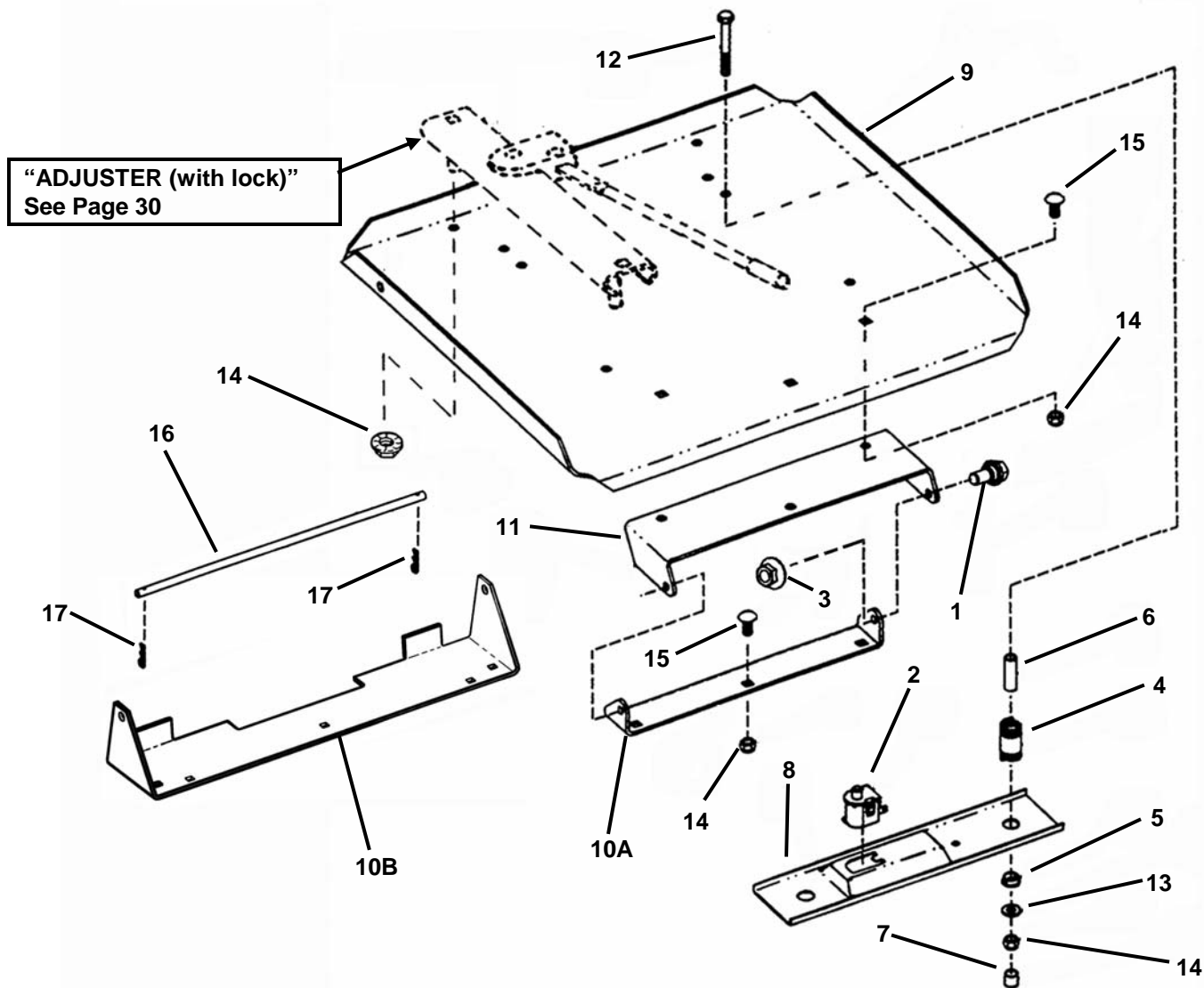

ITEM	PART NO.	DESCRIPTION
1	1-5761	BOLT, 5/16-18 Shoulder (2)
2	1-5707	SWITCH, Seat (Normally Open)
3	9-0951	NUT, 5/16-18 Hex Center Lock (2)
4	3-6492	SPRING, .106 Wire Dia., .68 I.D. x 1-1/2" (2)
--	9-2007	SPRING (Model EZF2100DKU)
5	2-2793	BUSHING, Molded Seat, 1/2 I.D. x 5/8" O.D. (2)
6	2-2794	SPACER, .31 I.D., 1-3/8" Long (2)
7	2-3606	CAP, Vinyl, 1/4 I.D. x 1/5 O.D. (2)
8	3-3362	HOLDER, Seat Switch
9	3-5827	PLATE, Seat Support (shown)
--	7-2015	PLATE, Seat Support (Model EZF2100DKU)
10A	7-2210	BRACKET, Lower Seat Hinge
10B	7-2034	BRACKET, Seat Hinge (Model EZF2100DKU)
11	3-5839	BRACKET, Upper Seat Support Hinge
12	9-1046	SCREW, 5/16-18 x 2-1/2" Hex Head Cap, Grade 5 (2)
13	9-1296	WASHER, 5/16 x 11/16 O.D. Flat (2)
14	9-1298	NUT, 5/16-18 Hex Nyloc (12)
15	9-1508	BOLT, 5/16-18 x 3/4 Short Sq. Nk. Carriage, Grade 5 (6)
16	1-9035	ROD, 5/16 x 13" Long (Item 1 used on later models)
17	9-1503	HAIRPIN, 3/32 x 1-1/2" (2) (used with item 16)

FENDER ASSEMBLY

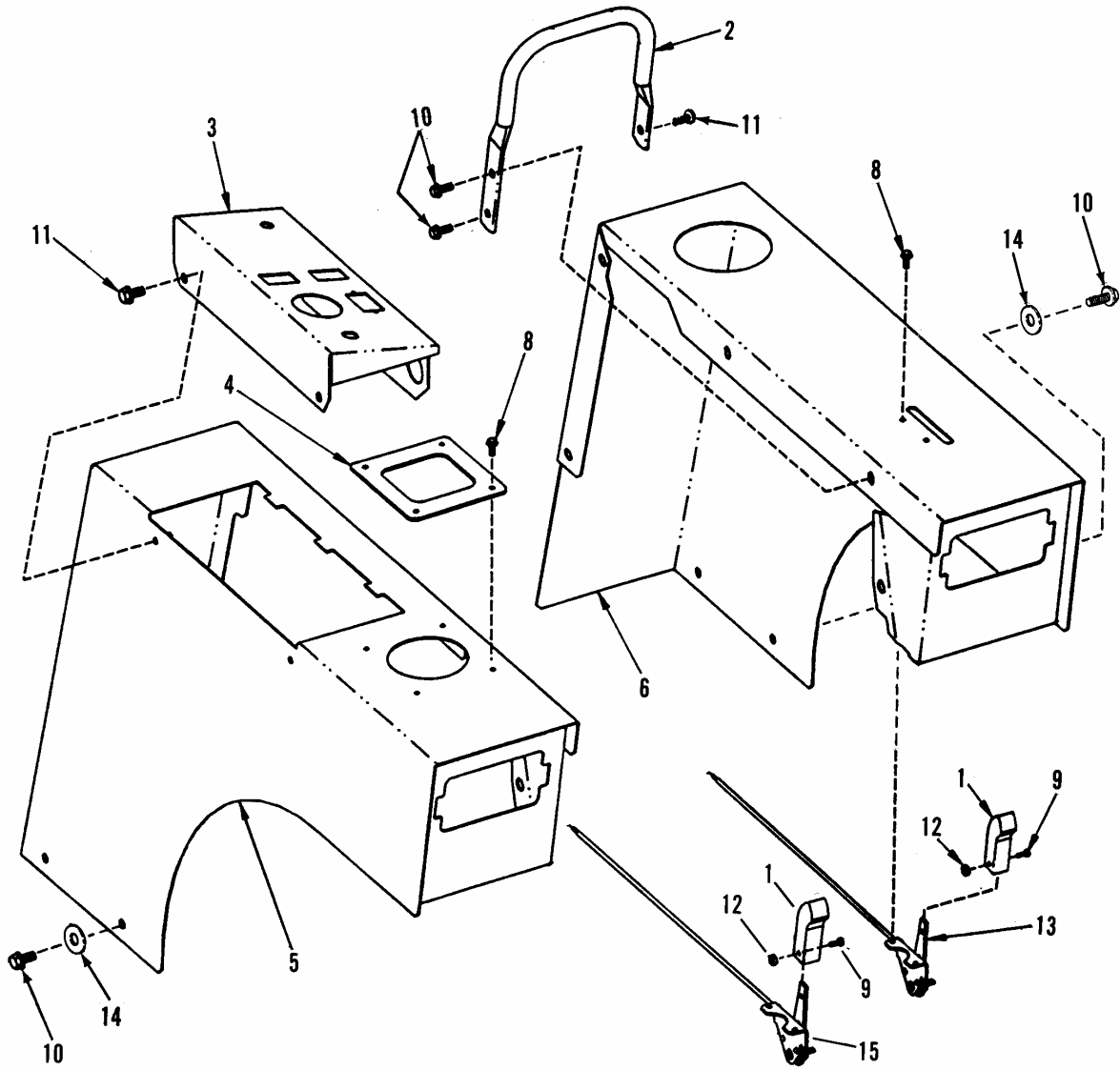

1	2-3655	LEVER, Throttle Control
2	3-5548	HANDLE, 5/8" Tubing
3	4-1909	PANEL, Instrument
4	3-5940	PLATE, Joystick Control
5	4-2642	FENDER, Right Hand
6	4-4933	FENDER, Left Hand (21 HP Diesel Engine)
--	4-2643	FENDER, Left Hand (23 HP Gas Engine)
7	2-4649	WIRE Tie, 11" (Not Shown)
8	9-0913	SCREW, #10-24 x 1/2" Hex Self-Tapping (6)
9	9-1017	SCREW, #8-32 x 3/8" Machine
10	9-1523	SCREW, 5/16-18 x 5/8" Hex Self-Tapping (15)
11	9-1787	SCREW, 1/4-20 x 5/8" Hex Flange Lock (3)
12	9-1018	NUT, #8-32 Hex
13	4-5213	CONTROL, Engine Speed (21 HP Diesel Engine)
--	7-1988	CONTROL, Engine Speed (23 HP Gas Engine)
14	9-1130	WASHER, 5/16 I.D. Flat (12)
15	7-2054	CONTROL, Choke (23 HP Gas Engine)
--	7-1989	CABLE, Engine Speed (23 HP Gas Engine) (Not Shown)

REAR PTO ASSEMBLY

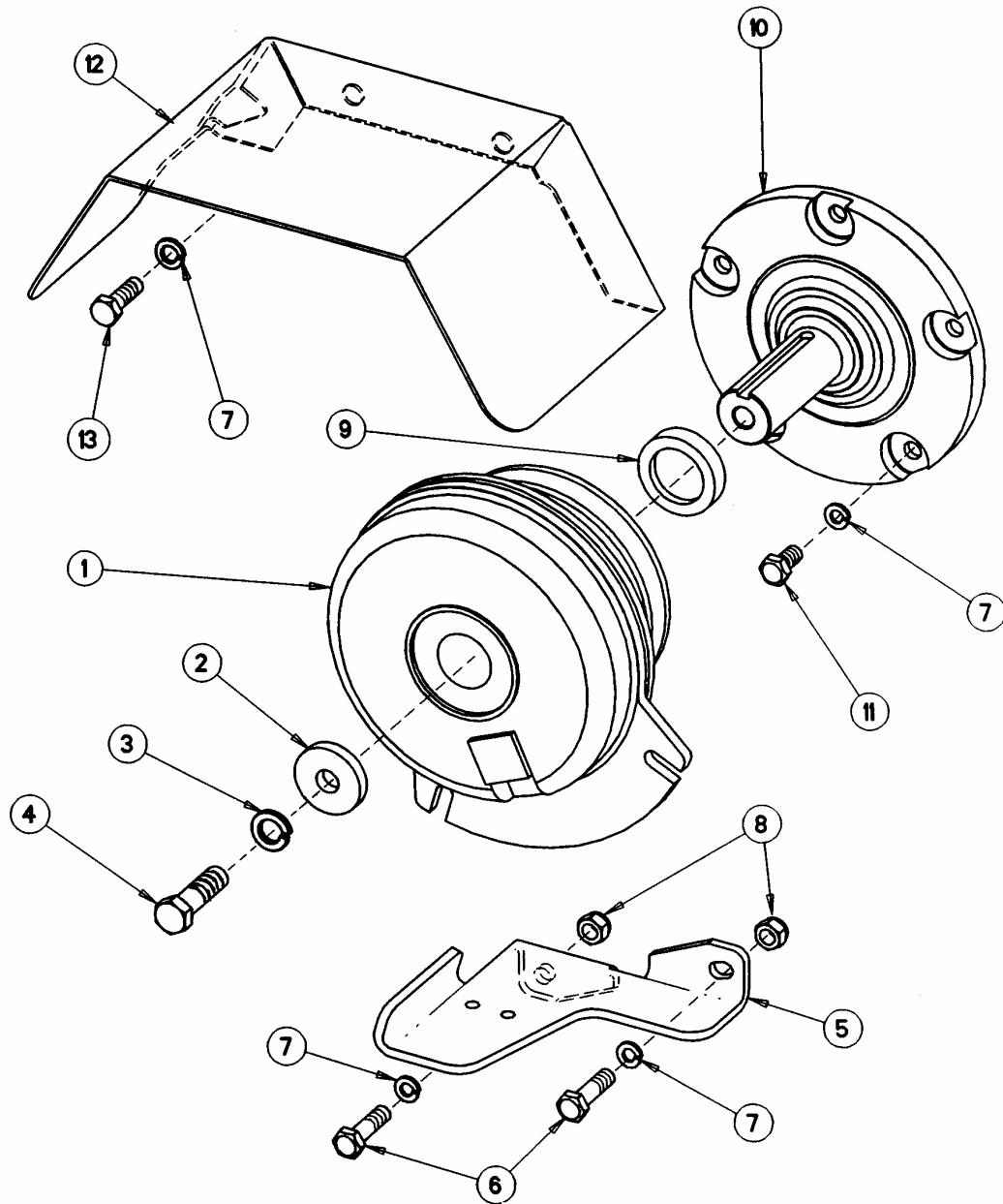

1	3-5520	ELECTRIC CLUTCH
--	5-8925	ELECTRIC CLUTCH (same as above but has spun steel pulley)
2	9-1807	SPACER, Clutch
3	9-1301	WASHER, 7/16 Split Lock
4	9-1763	SCREW, 7/16-20 x 1-1/2" Hex Head Cap, Grade 5
5	4-5253	BRACKET, Clutch Torque
6	9-1924	SCREW, M8-1.25 x 30 Hex Head Cap (2)
7	9-1315	WASHER, .32 Split Lock (9)
8	7-6975	NUT, M8-1.25 Hex Nyloc (2)
9	4-5232	SPACER, Clutch
10	4-5231	SHAFT, PTO
11	9-1925	SCREW, M8-1.25 x 16mm Hex Head Cap (5)
12	4-5293	BRACKET, Clutch Guard
13	9-1933	SCREW, M8-1.25 x 25mm Hex Head Cap (2)

TRACTION DRIVE IDLER ASSEMBLY

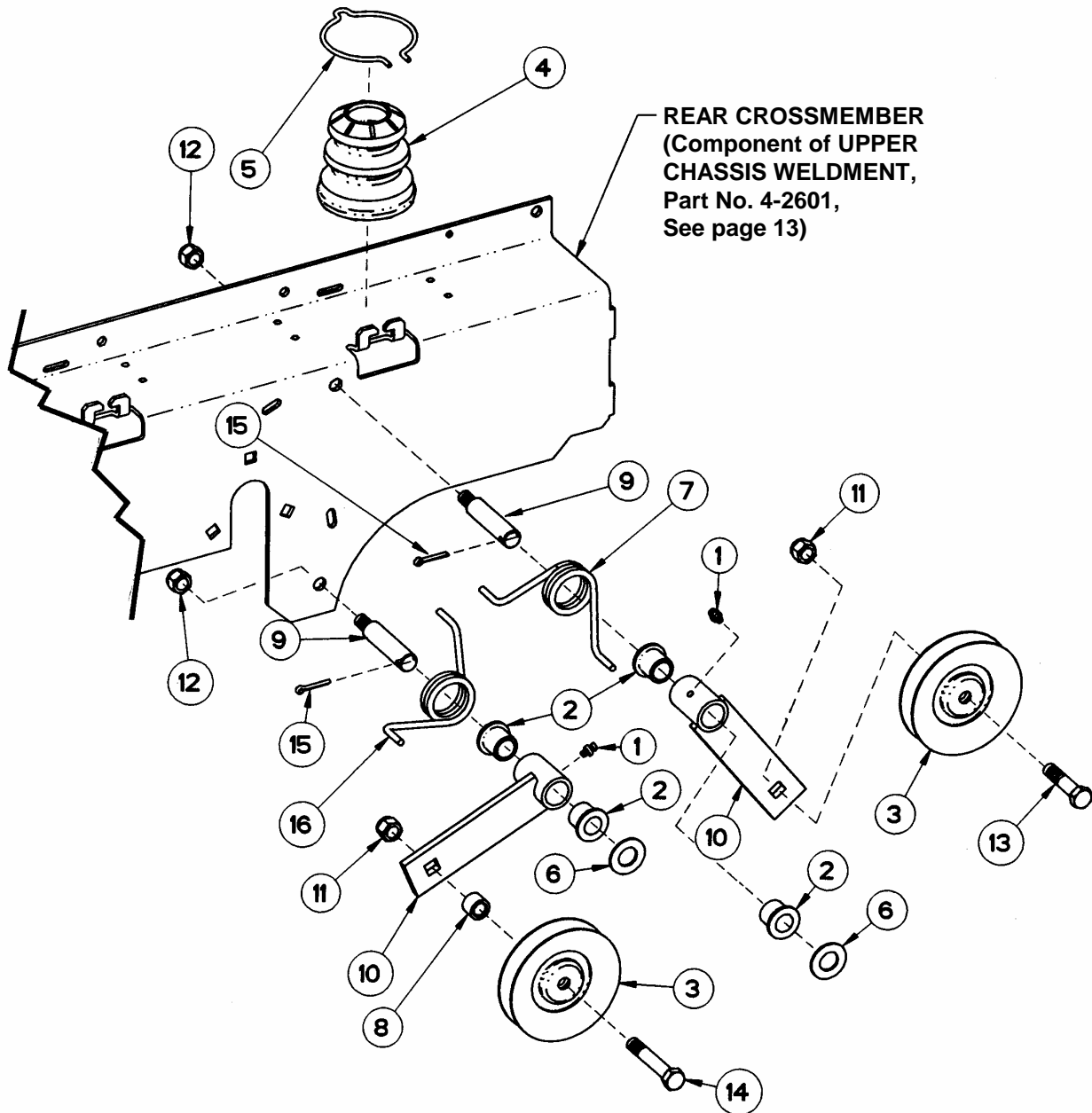

REAR CROSSMEMBER
(Component of UPPER
CHASSIS WELDMENT,
Part No. 4-2601,
See page 13)

ITEM	PART NO.	DESCRIPTION
1	1-3324	FITTING, 3/16 Lube (2)
2	1-4409	BUSHING, 9/16 I.D., 3/4" O.D. (4)
3	1-8573	PULLEY, Idler 3.48 O.D. (2)
4	1-9109	COVER, Spring (Rubber) (2)
5	1-9348	CLIP, Seat Cushion (2)
6	9-1804	WASHER, 9/16 Flat (2)
7	3-5713	SPRING, Torsion
8	3-5812	SPACER, 3/8 I.D. 5/8 O.D. x 5/8" Long
9	3-5816	PIN, 3/8-24 (2)

ITEM	PART NO.	DESCRIPTION
10	4-2622	IDLER ARM (Weldment) (2)
11	9-1299	NUT, 3/8-16 Hex Nyloc (2)
12	9-1518	NUT, 3/8-24 Hex Nyloc (2)
13	9-1553	SCREW, 3/8-16 x 1-3/4" Hex Head Cap, Grade 5
14	9-1560	SCREW, 3/8-16 x 2-1/4" Hex Head Cap, Grade 5
15	9-1598	COTTER PIN, 1/8 x 3/4" (2)
16	3-6562	SPRING, Torsion

FRONT DRIVE SHAFT ASSEMBLY

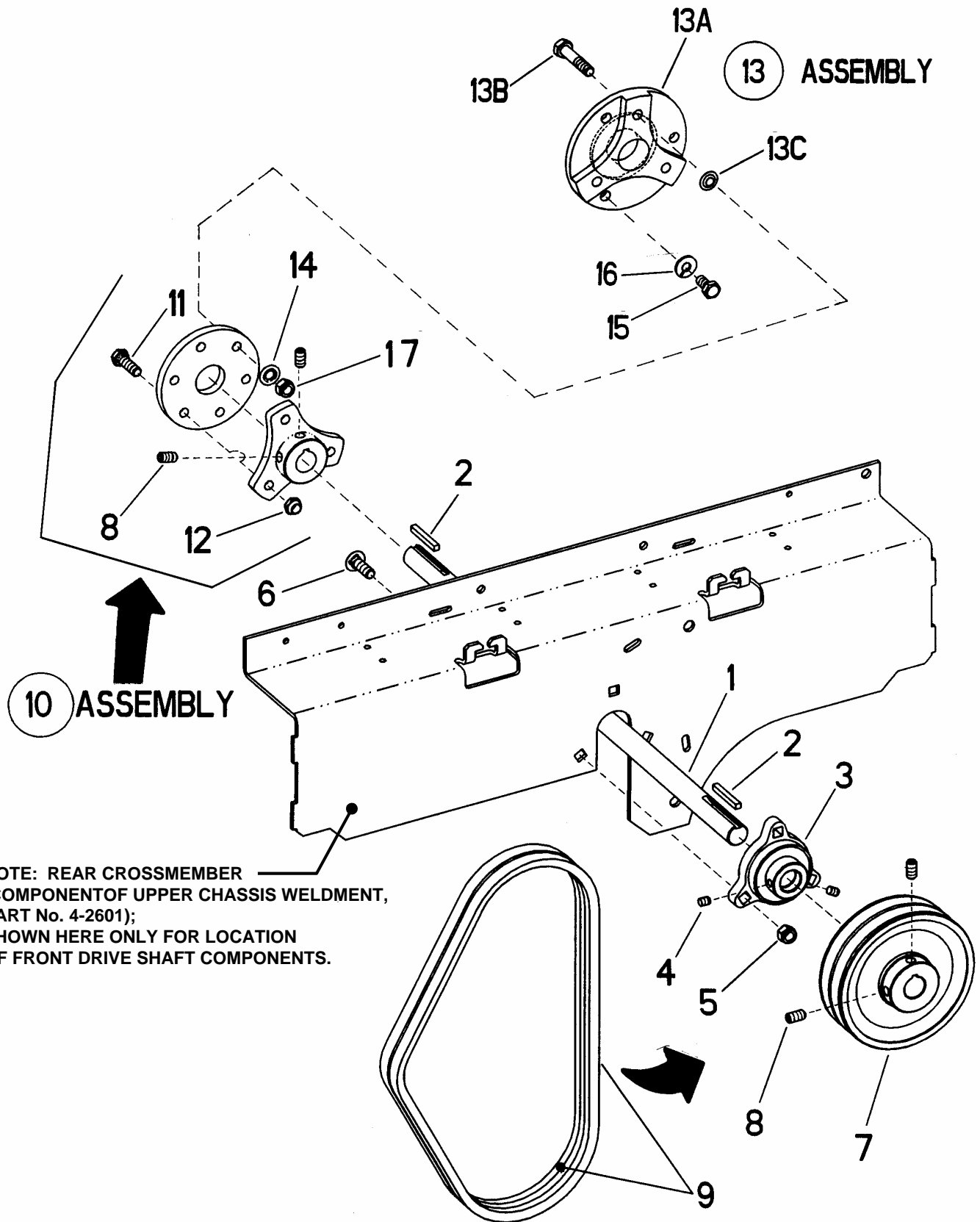

FRONT DRIVE SHAFT ASSEMBLY

ITEM	PART NO.	DESCRIPTION
1	4-5307	DRIVE SHAFT, 3/4"
2	9-1803	KEY, 3/16 Square x 1-1/2" Long (2)
3	5-4655	ASSEMBLY, Bearing/Lock Collar (Includes item 4 (2))
4	9-0471	SET-SCREW, 1/4-20 x 5/16" Socket-Head (2)
5	9-1298	NUT, 5/16-18 Hex Nyloc (3)
6	9-1714	BOLT, 5/16-18 x 1" Round Head Square Neck, Grade 5 (3)
7	3-5564	PULLEY, Cast Iron Dual V, 49.5 Effective O.D.
8	9-1802	SET-SCREW, 5/16-18 x 5/8", Socket-Head (4)
9	3-5544	BELT, 36-1/2" (2) (Upper Drive Shaft to Hydro Pump)
10	4-5221	FLEX COUPLING, 3/4" Shaft (Includes Item 8 (2), item 11 (3) & item 12 (3))
11	9-0238	SCREW, 5/16-24 x 1" Hex Head Cap, Grade 5 (3)
12	1-1201	NUT, 5/16-24 Hex Lock (3)
13	5-4678	ASSEMBLY, Coupling Adapter (Includes items 13A, 13B & 13C)
13A	4-5317	ADAPTER, Coupling
13B	9-1540	SCREW, 5/16-18 x 1-1/2" Hex Head Cap, Grade 5 (3)
13C	1-1791	RETAINER, 5/16 Bolt (3)
14	9-1936	WASHER, 5/16 Double Beaded (6)
15	9-1953	SCREW, M8-1.25 x 20 Hex Head Cap (3)
16	9-1315	WASHER, .32 I.D. Split Lock (3)
17	9-1706	NUT, 5/16-18 Hex Top Lock, Grade B (3)

DECK DRIVE SHAFT ASSEMBLY

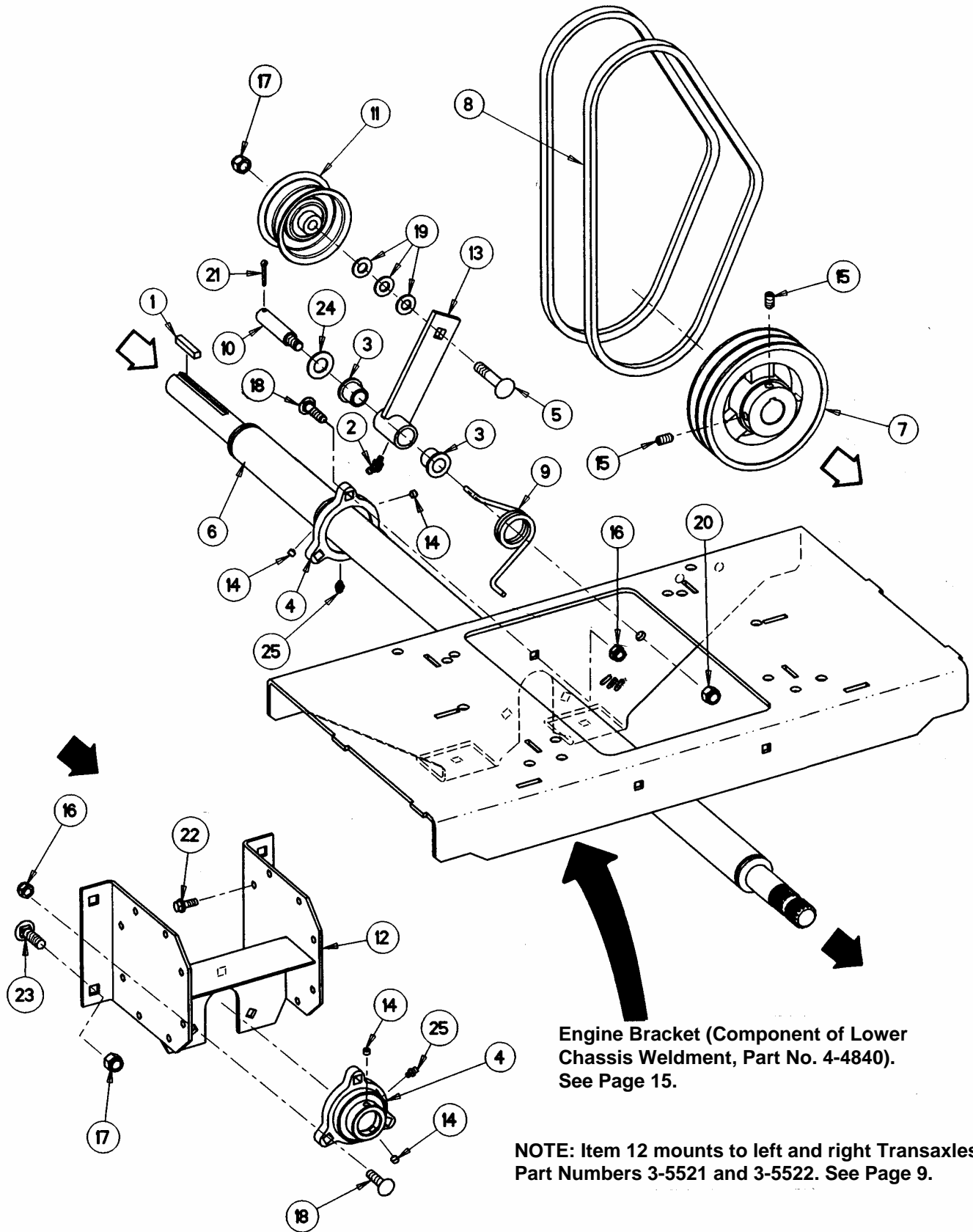

DECK DRIVE SHAFT ASSEMBLY

ITEM	PART NO.	DESCRIPTION
1	1-2315	KEY, 1/4 Square x 2"
2	1-3324	FITTING, Lube
3	1-4409	BUSHING (2)
4	5-4658	ASSEMBLY, Bearing (2)
5	9-0990	BOLT, 3/8-16 x 2" Square Neck Carriage, Grade 2
6	4-5234	DRIVESHAFT, Deck
7	3-5531	PULLEY, Double V (5.45 O.D.)
8	4-1830	BELT, Deck Drive (HA 37.25) (NOTE: Connects Deck Drive Shaft to Electric Clutch) (Sold as a pair)
9	3-5713	SPRING, Tension
10	3-5816	PIN, 3/8-24
11	3-5867	FLAT IDLER, 2.75 O.D. x 1-1/4" Wide
12	4-5229	BEARING MOUNT (Weldment)
13	4-2622	IDLER ARM (Weldment)
14	9-0776	SET SCREW, 1/4-20 x 1/4" Cone Point (4)
15	9-1802	SET SCREW, 5/16-18 x 5/8" Knurled Cup Point (2)
16	9-1298	NUT, 5/16-18 Hex Nyloc (6)
17	9-1299	NUT, 3/8-16 Hex Nyloc (5)
18	9-1928	BOLT, 5/16-18 x 1-1/4" Grade 5 (6)
19	9-1514	WASHER, 13/32 x 13/16 Flat (3)
20	9-1518	NUT, 3/8-24 Hex Nyloc
21	9-1598	COTTER-PIN, 1/8 x 3/4"
22	9-1787	SCREW, 1/4-20 x 5/8", Hex Flange Lock, Grade 5 (16)
23	2-7181	BOLT, 3/8-16 x 1-1/4" Short Neck Carriage, Grade 5 (4)
24	9-1804	WASHER, 9/16 Flat
25	1-3864	FITTING, Lube (2)

SEAT ASSEMBLY (5-4117)

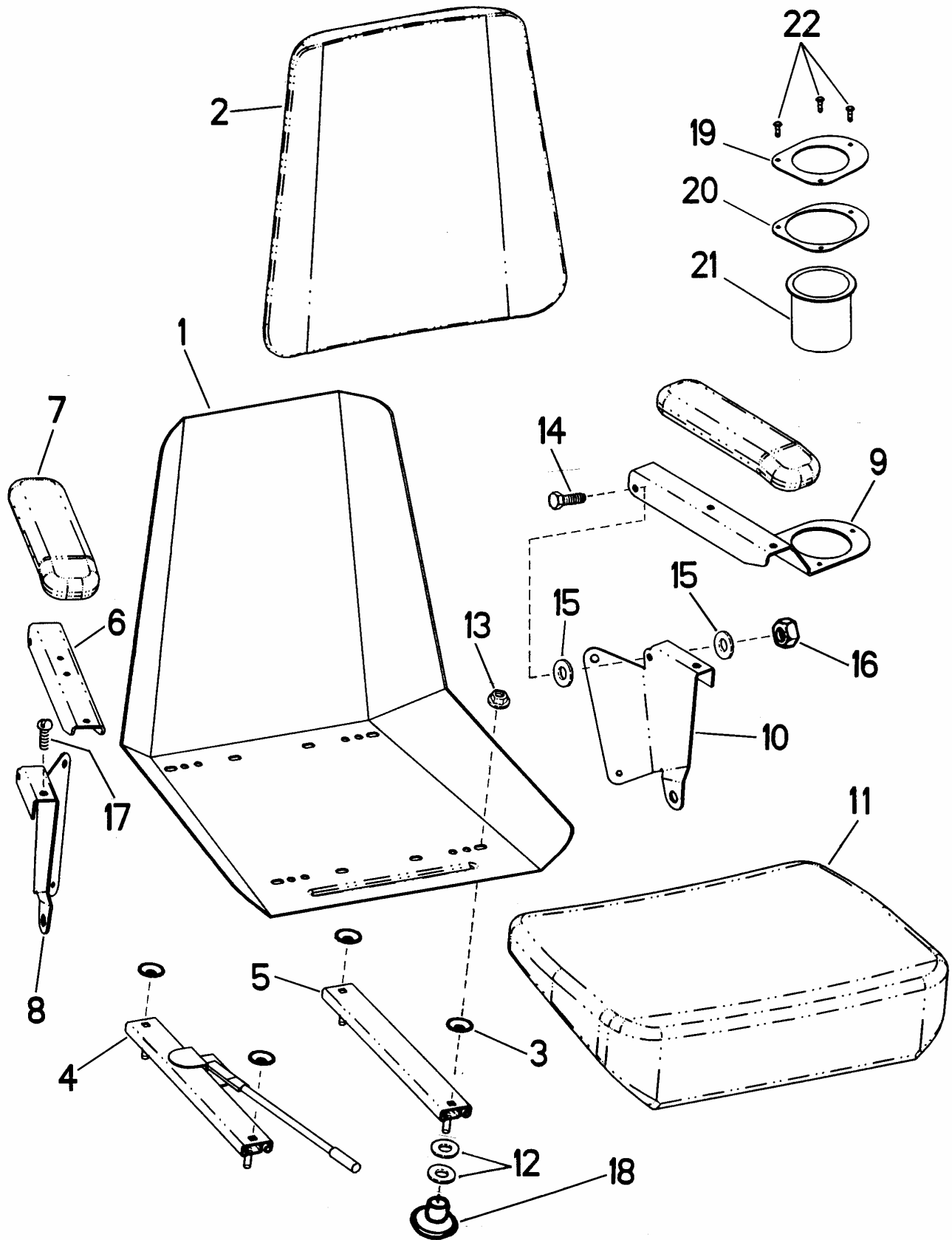

SEAT ASSEMBLY (5-4117)

ITEM	PART NO.	DESCRIPTION
1*	--	PAN, Seat
2	3-6477	SEAT CUSHION, Back
3	3-6486	SPACER, Bell (4)
4	3-6484	SLIDE ADJUSTER, Seat (w/lock)
5	3-6485	SLIDE ADJUSTER, Seat (w/o lock)
6	3-6478	CHANNEL, Armrest
7	3-6479	PAD, Armrest (2)
8	3-5567	BRACKET RH, Armrest
9	4-4904	BRACKET, Armrest Cup Holder
10	3-5568	BRACKET LH, Armrest
11	3-6476	SEAT CUSHION, Bottom
12	9-1296	WASHER, 11/32" (8)
13	9-1601	NUT, 5/16-18 Hex Flange Lock, Grade 5 (6)
14	2-7174	SCREW, 5/16-18 x 2" Hex Head Cap, Grade 5 (2)
15	3-5797	WASHER, 3/8: I.D. Poly (4)
16	9-1067	NUT, 5/16-18 Hex Head Centerlock, Grade B (2)
17	9-0683	SCREW, 5/16-18 x 1" Slotted Pan Head
18*	--	STUD GUARD (4)
19	4-4903	COVER, Cupholder
20	4-4902	SPACER, Cupholder
21	4-2968	HOLDER, Beverage
22	9-1919	RIVET, 3/16 Pan Head (3)

***NOTE: Not a part sales item.**

52" MOWER DECK COMPONENTS

(page 1 of 4)

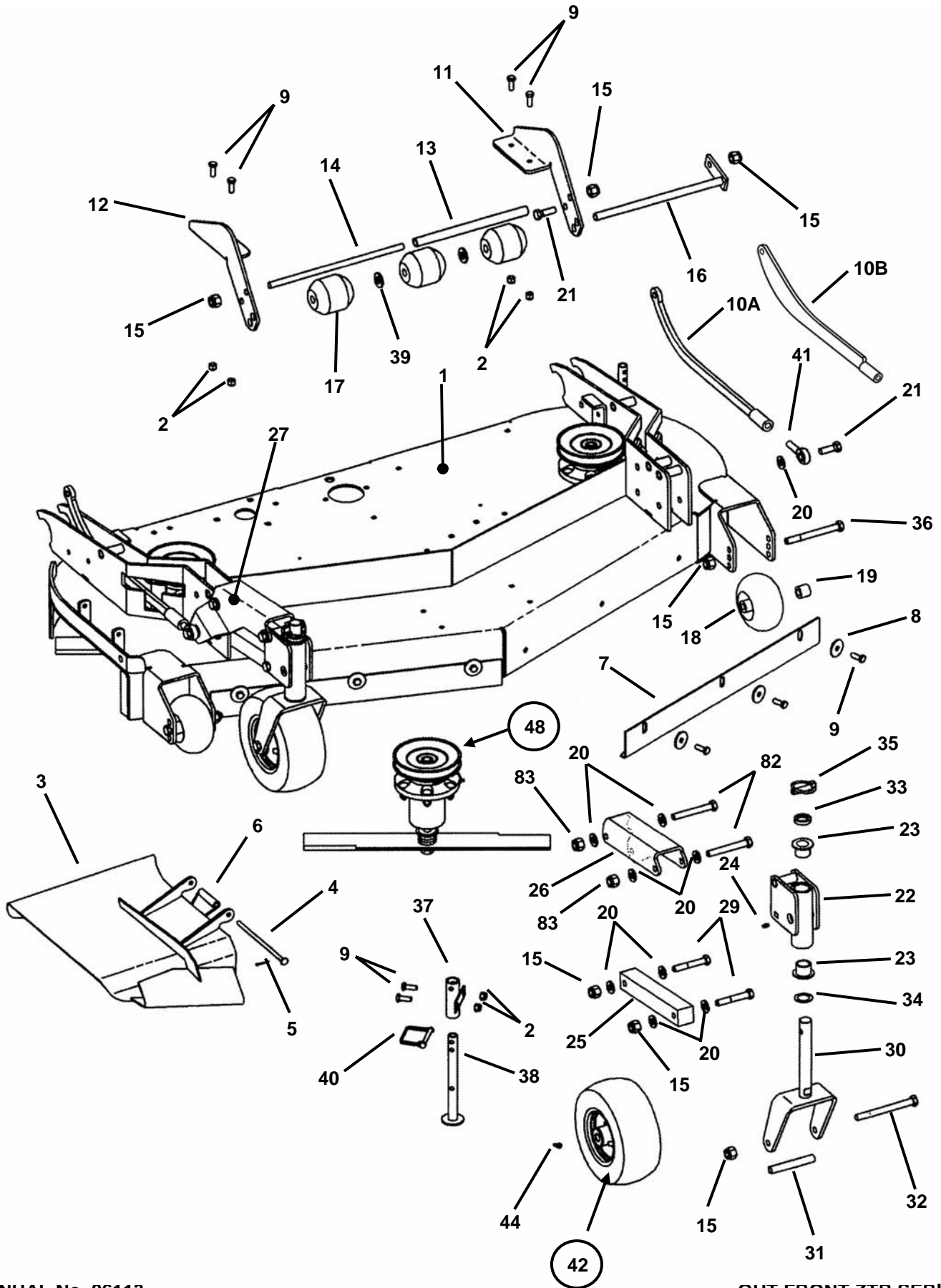

52" MOWER DECK COMPONENTS

(page 2 of 4)

ITEM	PART NO.	DESCRIPTION
1	4-2898	WELDMENT, 52" Deck- Adjustable Height
2	9-1299	NUT, 3/8-16 Hex Nyloc (23)
3	4-2903	DEFLECTOR, Chute 52"
--	5-8285	DEFLECTOR, Chute 52" Euro (Weldment)
4	2-9277	PIN, Chute Hinge
5	9-1313	PIN, 3/32 x 1" Cotter
6	2-7950	SPRING, Chute
7	4-2914	BAFFLE, Front (2)
8	9-1331	WASHER, 13/32 x 1-1/2" Flat (8)
9	9-1304	SCREW, 3/8-16 x 1" Hex Head Cap, Grade 5 (21)
10A	4-6495	LINK, Height of Cut (2)
10B	5-3437	LINK, Height of Cut, Heavy Duty (may be substituted for 4-6495)
11	3-6459	MOUNT, Roller Left Hand
12	3-6458	MOUNT, Roller Right Hand
13	3-6460	TUBE, Roller
14	3-6461	PIN, Roller
15	9-1325	NUT, 1/2-13 Hex Nyloc (15)
16	2-7327	WELDMENT, Shaft
17	7-9226	ROLLER, Low Density Polyethylene (3)
18	2-9264	WHEEL, Gage (4)
19	3-6456	SPACER, Gage Wheel (4)
20	9-1587	WASHER, 1/2" Flat (26)
21	9-1884	SCREW, 1/2-13 x 1-1/2" Hex Head Cap, Grade 2 (3)
22	4-2652	TUBE, Caster (Weldment) (2)
23	2-3556	BUSHING, Caster (4)
24	7-6998	FITTING, Lube 1/4-28 Straight (4)
25	3-6444	ARM, Lower Caster (2)
26	4-2655	ARM, Caster Support Left Hand
27	4-2653	ARM, Caster Support Right Hand
28	2-9355	BOLT, 1/2-13 x 3-3/4" Hex Head Cap, Grade 5 (2)
29	9-1821	BOLT, 1/2-13 x 3" Hex Head (9)
30	4-2780	WELDMENT, Caster (2)
31	2-2151	SLEEVE, Axle (2)
32	9-1326	SCREW, 1/2-13 x 5-1/2" Hex Head Cap, Grade 5 (2)
33	2-1960	SPACER, Powdered Metal (2)
34	2-3747	BUSHING, Machine (2)
35	1-7711	PIN, 7/16" HD Lynch (2)
36	9-1822	BOLT, 1/2-13 x 5" Hex Head Cap, Grade 5 (5)
37	4-2657	TUBE, Jack Stand (Weldment) (2)
38	4-2658	WELDMENT, Jack Stand (2)
39	2-7344	WASHER, 5/8" Flat (2)
40	9-1824	PIN, 5/16" Lynch (2)
41	3-6465	BALLJOINT, 1/2-20 (2)
42	5-7762	ASSEMBLY, Wheel/Tire (2) (Includes items 43 Thru 47)
43	4-6540	TIRE, Carefree 4.10-4
44	4-6430	FITTING, Grease 1/4"
45	4-6541	RIM, Steel (White) 1-3/8" Bore w/o Air Valve
46	2-2395	BEARING, Roller
47	2-2394	BEARING, Flanged (2)
48	5-4477	GROUP, Spindle (3) (See Page 24 for parts breakdown)

NOTE: 5-7735 (Height of Cut Linkage Assembly) is comprised of items 10A & 41.

52" MOWER DECK COMPONENTS

(page 3 of 4)

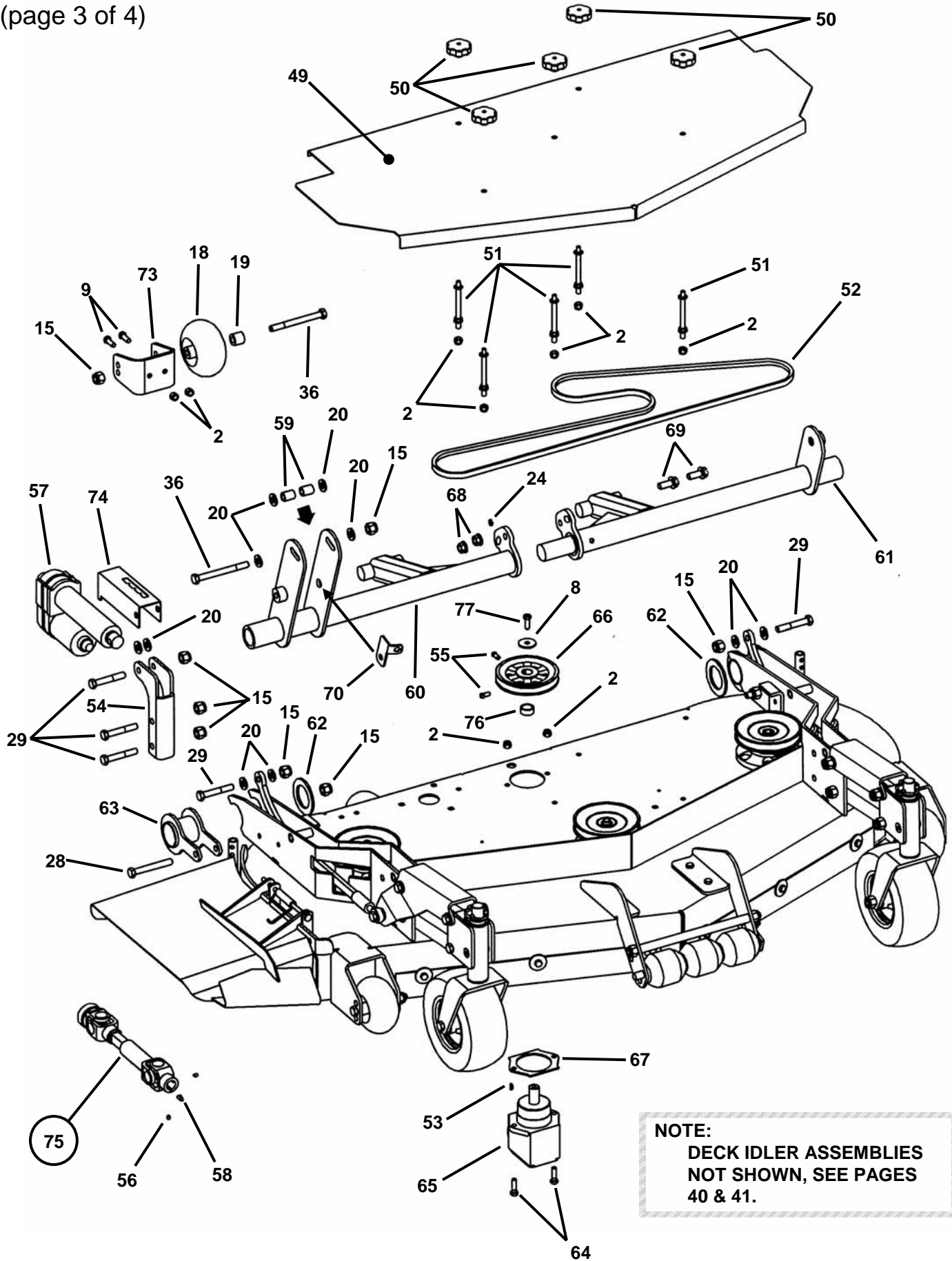

NOTE:
DECK IDLER ASSEMBLIES
NOT SHOWN, SEE PAGES
40 & 41.

52" MOWER DECK COMPONENTS

(page 4 of 4)

ITEM	PART NO.	DESCRIPTION
49	4-6728	COVER, 52" Deck
50	2-3735	KNOB, 5/16-18 Thread (5)
51	2-9303	STANDOFF, 3-1/2" (5)
52	4-2776	V-BELT, 52" Deck (122") HB
53	1-0008	KEY, #6 Woodruff
54	3-6447	MOUNT, Motor (Front)
55	9-1802	SCREW, 5/16-18 x 5/8" Square Head Set w/locking patch (2)
56	9-0132	SCREW, 3/8-16 x 3/8" Hex Recess Set (2)
57	3-6448	SCREWJACK, Warner Electric 1000 lbs.
58	1-0211	KEY, #9 Woodruff
59	3-6453	SPACER, Motor, Rear (2)
60	4-2900	MAIN LINK (Weldment)
61	4-2901	MAIN LINK (Weldment) Left Hand
62	3-6452	SPACER, Tube (2)
63	4-2660	HOLDER, Pivot (Weldment) (2)
64	9-1328	SCREW, 3/8-16 x 1-1/4" Hex Head Cap, Grade 5 (2)
65	5-8342	GEARBOX, Right Angle (Peerless P/N 1000-52)
66	4-2867	PULLEY, Cast 5.75" Outside Diameter
67	3-6455	SHIM, Gearbox
68	9-1544	NUT, 1/2-13 Hex Flange Lock, Grade 5 (2)
69	9-1323	BOLT, 1/2-13 x 1-1/4" Hex Flange Lock, Grade 5 (2)
70	3-6450	BRACKET, Strain Relief
71	3-5779	RELIEF, Strain (see page 48)
72	4-2834	HARNESS, Deck Lift (see page 50)
73	3-6457	BRACKET, Gage Wheel (2)
74	3-6454	INDICATOR, Height-of-Cut (2)
75	5-4104	ASSEMBLY, Telescoping Drive Shaft (includes two set screws, p/n 9-0201 and one 1/4-28 grease fitting, p/n 1-2700)
76	3-5668	SPACER
77	9-0160	SCREW, 3/8-24 x 1" Hex Head Cap, Grade 5
78	2-6107	GREASE, Multi-Purpose
79	6-1865	HARDWARE BAG, Drive Shaft (Incl. indented items below)
80	1-0211	KEY, #9 Woodruff
81	9-0132	SCREW, 3/8-16 Hex Recess Set (2)
82	9-0993	SCREW, 1/2-20 x 4-1/2" Hex Head Cap, Grade 5 (4)
83	9-0393	NUT, 1/2-20 Hex Nyloc (4)

61" MOWER DECK COMPONENTS

(page 1 of 4)

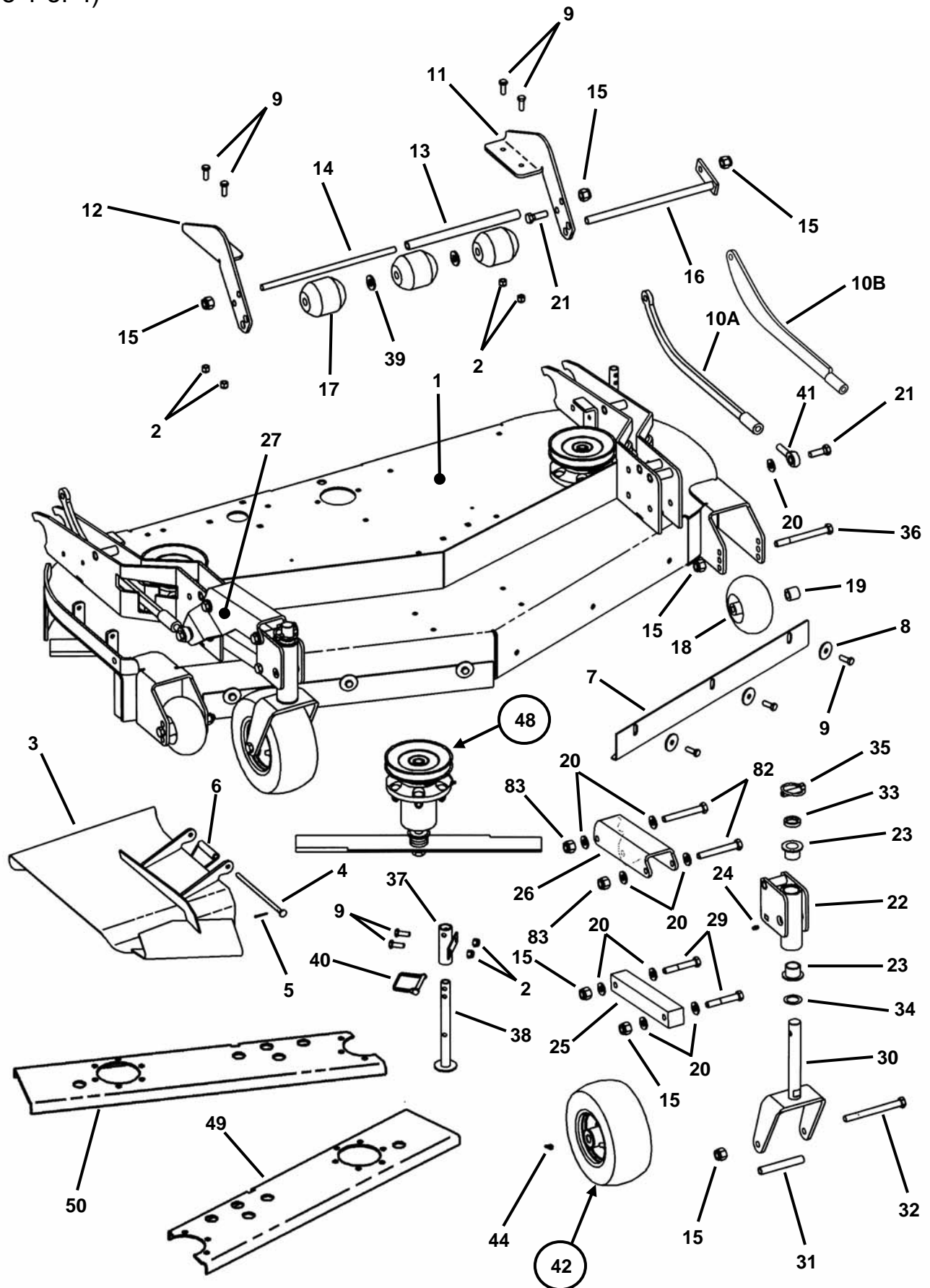

61" MOWER DECK COMPONENTS (page 2 of 4)

ITEM	PART NO.	DESCRIPTION
1	4-2651	WELDMENT, 61" Deck- Adjustable Height
2	9-1299	NUT, 3/8-16 Hex Nyloc (14)
3	4-2656	DEFLECTOR, Chute 61"
--	5-8291	DEFLECTOR, Chute 61" Euro (Weldment)
4	2-9277	PIN, Chute Hinge
5	9-1313	PIN, 3/32 x 1" Cotter
6	2-7950	SPRING, Chute
7	3-6445	BAFFLE, Front (2)
8	9-1331	WASHER, 13/32 x 1-1/2" Flat (7)
9	9-1304	SCREW, 3/8-16 x 1" Hex Head Cap, Grade 5 (18)
10A	4-6495	LINK, Height of Cut (2)
10B	5-3437	LINK, Height of Cut, Heavy Duty (may be substituted for 4-6495)
11	3-6459	MOUNT, Roller Left Hand
12	3-6458	MOUNT, Roller Right Hand
13	3-6460	TUBE, Roller
14	3-6461	PIN, Roller
15	9-1325	NUT, 1/2-13 Hex Nyloc (21)
16	2-7327	WELDMENT, Shaft
17	7-9226	ROLLER, Low Density Polyethylene (3)
18	2-9264	WHEEL, Gage (4)
19	3-6456	SPACER, Gage Wheel (4)
20	9-1587	WASHER, 1/2" Flat (26)
21	9-1884	SCREW, 1/2-13 x 1-1/2" Hex Head Cap, Grade 2 (3)
22	4-2652	TUBE, Caster (Weldment) (2)
23	2-3556	BUSHING, Caster (4)
24	7-6998	FITTING, Lube 1/4-28 Straight (4)
25	3-6444	ARM, Lower Caster (2)
26	4-2655	ARM, Caster Support Left Hand
27	4-2653	ARM, Caster Support Right Hand
28	2-9355	BOLT, 1/2-13 x 3-3/4" Hex Head Cap, Grade 5 (2)
29	9-1821	BOLT, 1/2-13 x 3" Hex Head (9)
30	4-2780	WELDMENT, Caster (2)
31	2-2151	SLEEVE, Axle (2)
32	9-1326	SCREW, 1/2-13 x 5-1/2" Hex Head Cap, Grade 5 (2)
33	2-1960	SPACER, Powdered Metal (2)
34	2-3747	BUSHING, Machine (2)
35	1-7711	PIN, 7/16" HD Lynch (2)
36	9-1822	BOLT, 1/2-13 x 5" Hex Head Cap, Grade 5 (5)
37	4-2657	TUBE, Jack Stand (Weldment) (2)
38	4-2658	WELDMENT, Jack Stand (2)
39	2-7344	WASHER, 5/8" Flat (2)
40	9-1824	PIN, 5/16" Lynch (2)
41	3-6465	BALLJOINT, 1/2-20 (2)
42	5-7762	ASSEMBLY, Wheel/Tire (2) (Includes items 43 Thru 47)
43	4-6540	TIRE, Carefree 4.10-4
44	4-6430	FITTING, Grease 1/4"
45	4-6541	RIM, Steel (White) 1-3/8" Bore w/o Air Valve
46	2-2395	BEARING, Roller
47	2-2394	BEARING, Flanged (2)
48	5-4353	GROUP, Spindle (3) (See Page 24 for parts breakdown)
49	7-4818	STIFFENER, 61" Deck, Left Hand
50	7-4819	STIFFENER, 61" Deck, Right Hand

NOTE: 5-7735 (Height of Cut Linkage Assembly) is comprised of items 10A & 41.

61" MOWER DECK COMPONENTS

(page 3 of 4)

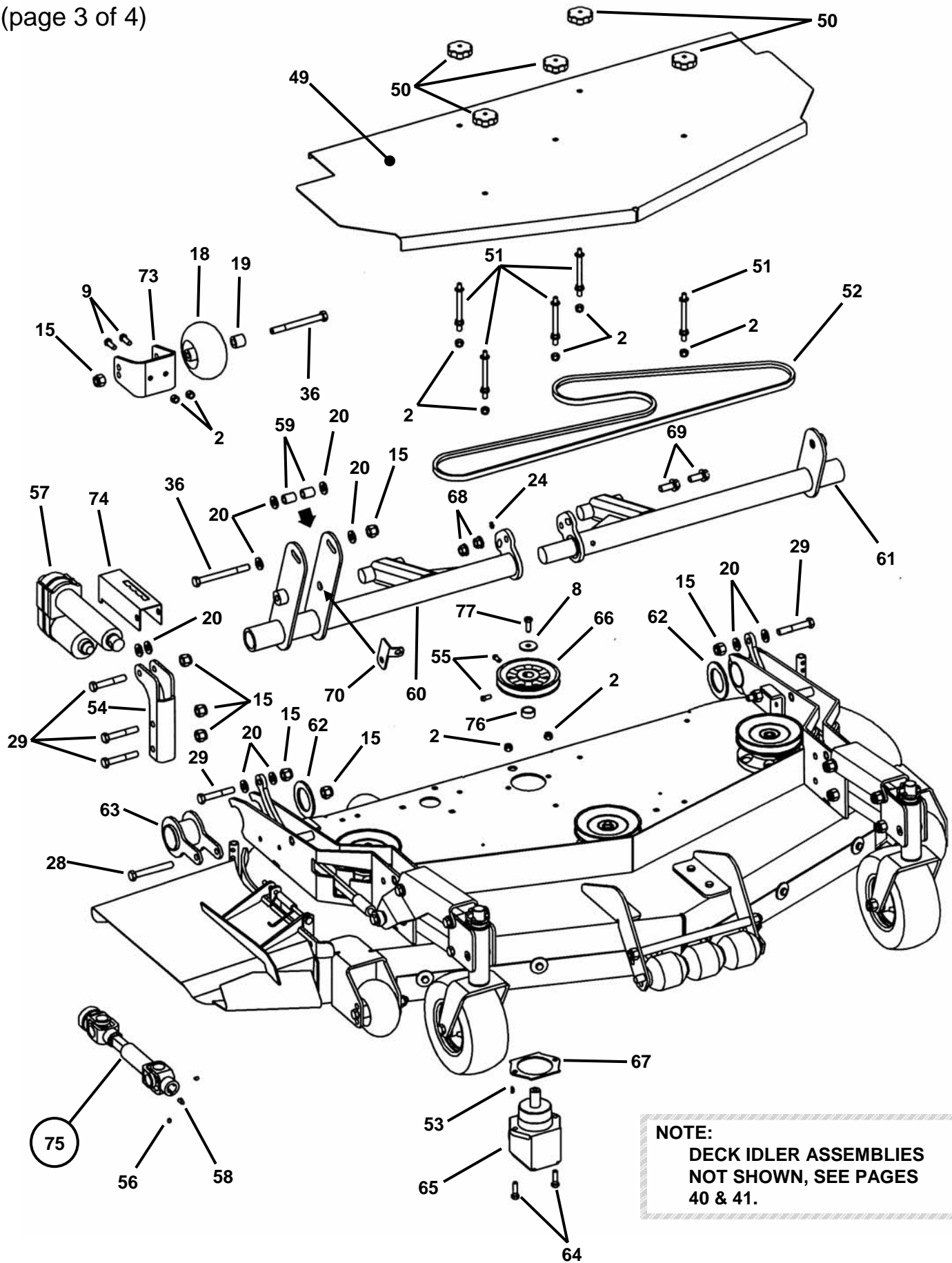

NOTE:
DECK IDLER ASSEMBLIES
NOT SHOWN, SEE PAGES
40 & 41.

61" MOWER DECK COMPONENTS

(page 4 of 4)

ITEM	PART NO.	DESCRIPTION
49	4-6729	COVER, 61" Deck
50	2-3735	KNOB, 5/16-18 Thread (4)
51	2-9303	STANDOFF, 3-1/2" (5)
52	3-5542	V-BELT, 61" (134.5") HB
53	9-1823	KEY, 5/32 x 5/8" Woodruff
54	3-6447	MOUNT, Motor (Front)
55	9-1802	SCREW, 5/16-18 x 5/8" Square Head Set w/locking patch (2)
56	9-0132	SCREW, 3/8-16 x 3/8" Hex Recess Set (2)
57	3-6448	SCREWJACK, Warner Electric 1000 lbs.
58	1-0211	KEY, #9 Woodruff
59	3-6453	SPACER, Motor, Rear (2)
60	4-2662	MAIN LINK (Weldment)
61	4-2661	MAIN LINK (Weldment) Left Hand
62	3-6452	SPACER, Tube (2)
63	4-2660	HOLDER, Pivot (Weldment) (2)
64	9-1328	SCREW, 3/8-16 x 1-1/4" Hex Head Cap, Grade 5 (2)
65	5-8342	GEARBOX, Right Angle (Peerless P/N 1000-52)
66	7-4466	PULLEY, Cast 5.45" Outside Diameter
67	3-6455	SHIM, Gearbox
68	9-1544	NUT, 1/2-13 Hex Flange Lock, Grade 5 (2)
69	9-1323	BOLT, 1/2-13 x 1-1/4" Hex Flange Lock, Grade 5 (2)
70	3-6450	BRACKET, Strain Relief
71	3-5779	RELIEF, Strain (see page 48)
72	4-2834	HARNESS, Deck Lift (see page 50)
73	3-6457	BRACKET, Gage Wheel (2)
74	3-6454	INDICATOR, Height-of-Cut (2)
75	5-4104	ASSEMBLY, Telescoping Drive Shaft (includes two set screws, p/n 9-0201 and one 1/4-28 grease fitting, p/n 1-2700)
76	3-5668	SPACER
77	9-0160	SCREW, 3/8-24 x 1", Grade 5
78	2-6107	GREASE, Multi-Purpose
79	6-1865	HARDWARE BAG, Drive Shaft (Incl. indented items below)
80	1-0211	KEY, #9 Woodruff
81	9-0132	SCREW, 3/8-16 Hex Recess Set (2)
82	9-0993	SCREW, 1/2-20 x 4-1/2" Hex Head Cap, Grade 5 (4)
83	9-0393	NUT, 1/2-20 Hex (4)

52" & 61" DECK IDLER ASSEMBLIES

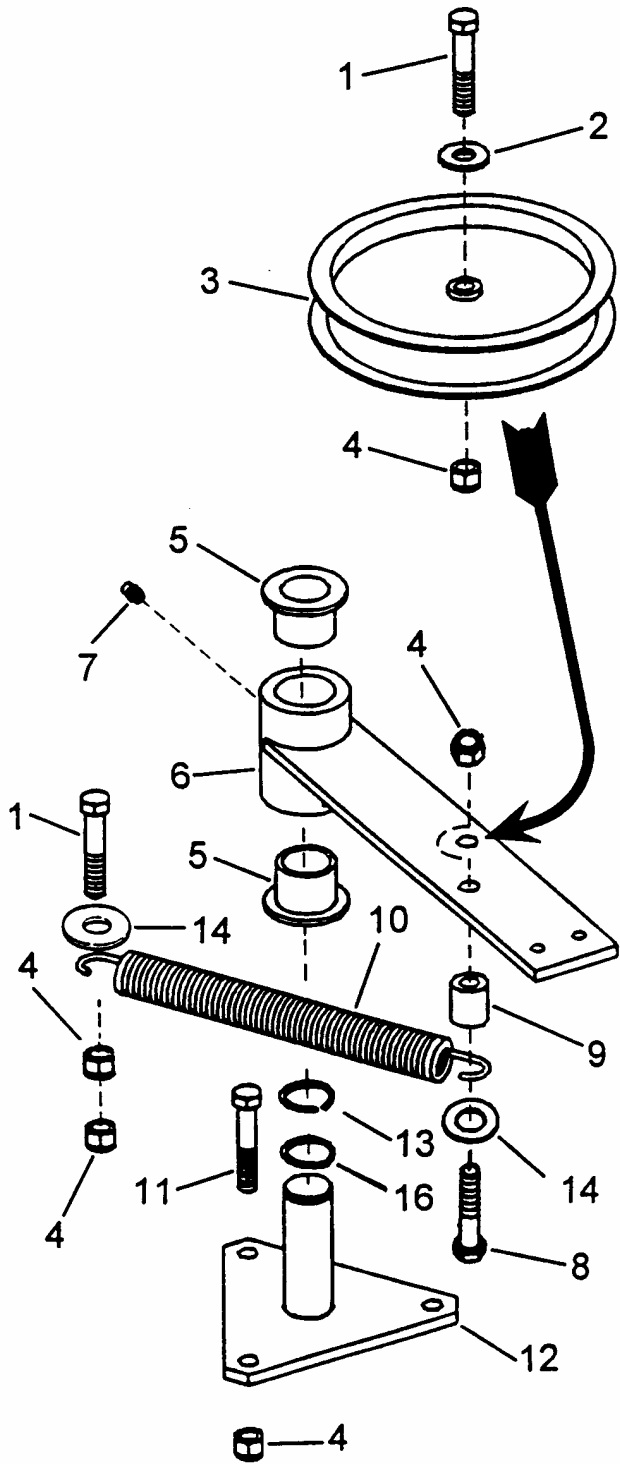

SPRING LOADED IDLER ASSEMBLY

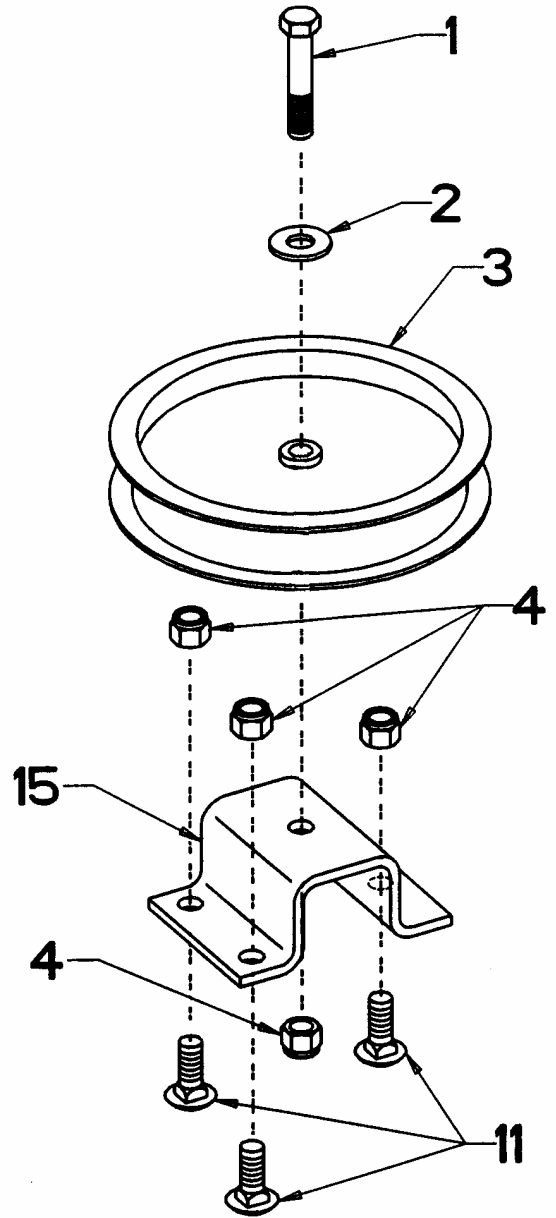

FIXED IDLER ASSEMBLY

52" & 61" DECK IDLER ASSEMBLIES

ITEM	PART NO.	DESCRIPTION
1	9-1305	SCREW, 3/8-16 x 2" Hex Head Cap, Grade 5 (2)
2	9-1300	WASHER, 3/8" Flat (2)
3	3-5789	PULLEY, Idler 5-1/2" O.D. (2)
4	9-1299	NUT, 3/8-16 Hex Nyloc (11)
5	2-3556	BUSHING (2)
6	4-2619	ARM, Idler (Weldment)
7	7-6998	FITTING, Lube 1/4-28 Straight
8	9-1553	SCREW, 3/8-16 x 1-3/4" Hex Head Cap, Grade 5 (2)
9	3-5858	SPACER, .50 I.D. x .75 O.D. x .83
10	3-5667	SPRING, Extension
11	9-1640	BOLT, 3/8-16 x 1" Square Neck Carriage, Grade 5 (6)
12	4-1295	PLATE, Tri-Mount (Weldment)
13	1-2709	E-RING 1"
14	9-1331	WASHER, .406 x 1.5 x .120 Yellow Zinc (2)
15	3-6449	STAND, Fixed Idler
16	3-2031	WASHER, 1.031 x 1.25

CUTTER HOUSING ASSEMBLY

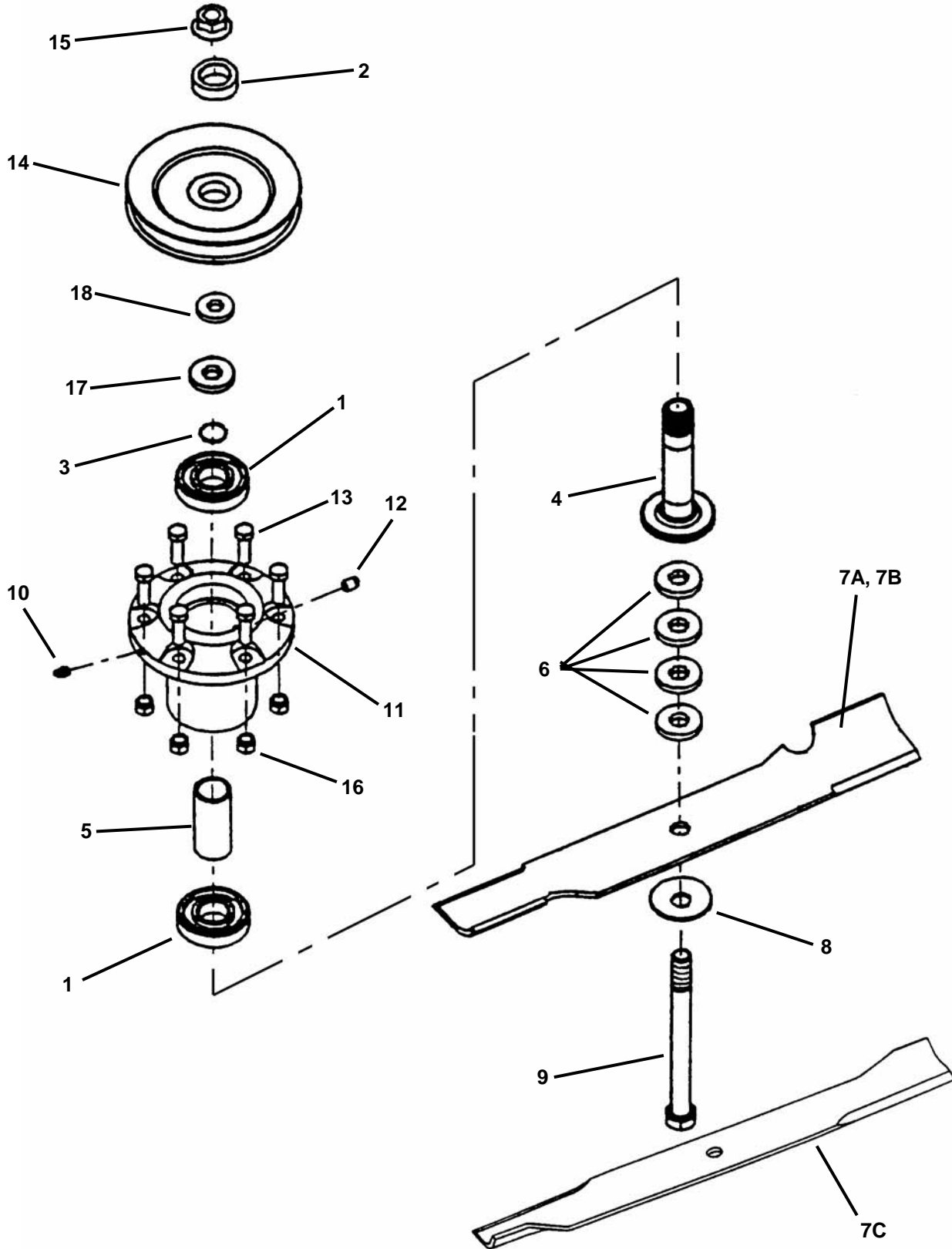

CUTTER HOUSING ASSEMBLY

ITEM	PART NO.	DESCRIPTION
1	2-9422	BEARING, Sealed (2)
2	2-9270	WASHER, Spindle
3	2-9274	SNAP-RING, Spindle Shaft
4	5-9311	SHAFT, Spindle
5	2-9254	SPACER, Bearing
6	2-9271	SPACER, Blade (4)
7A	2-9251	BLADE, 21" (61" Deck) (High Lift)
7B	2-9246	BLADE, 18" (52" Deck)
7C	1-7081	BLADE, 21" (61" Deck) (Low Lift)
8	1-6440	WASHER, Beveled
9	6-3234	BOLT, 5/8-11 x 7-1/2" Hex Head Cap, Grade 5
10	2-9275	FITTING, Lube
11	2-9252	HOUSING, Cutter
12	2-9384	VENT, Spindle
13	2-9302	BOLT, 3/8-16 x 1-1/4" Rib Necked (6)
14	2-9249	PULLEY, 5-3/4" O.D. (61" Deck)
15	6-3237	NUT, 5/8-11 Hex Flange Lock, Grade 5
16	9-1299	NUT, 3/8-16 Hex Nyloc (6)
--	6-3240*	KIT, Bearing Seal Field Fix (incl. items 17 & 18)
17	6-3238	SEAL, Nylos
18	1-3370	WASHER

NOTE: Part Number 5-4017 (Spindle Housing sub-assembly) is comprised of items 11 and 12 (one each) as well as item 13 (six each).

***NOTE: For bearing pre-seal kit installation, discard item 3 & replace with items 17 & 18 as shown.**

DECALS

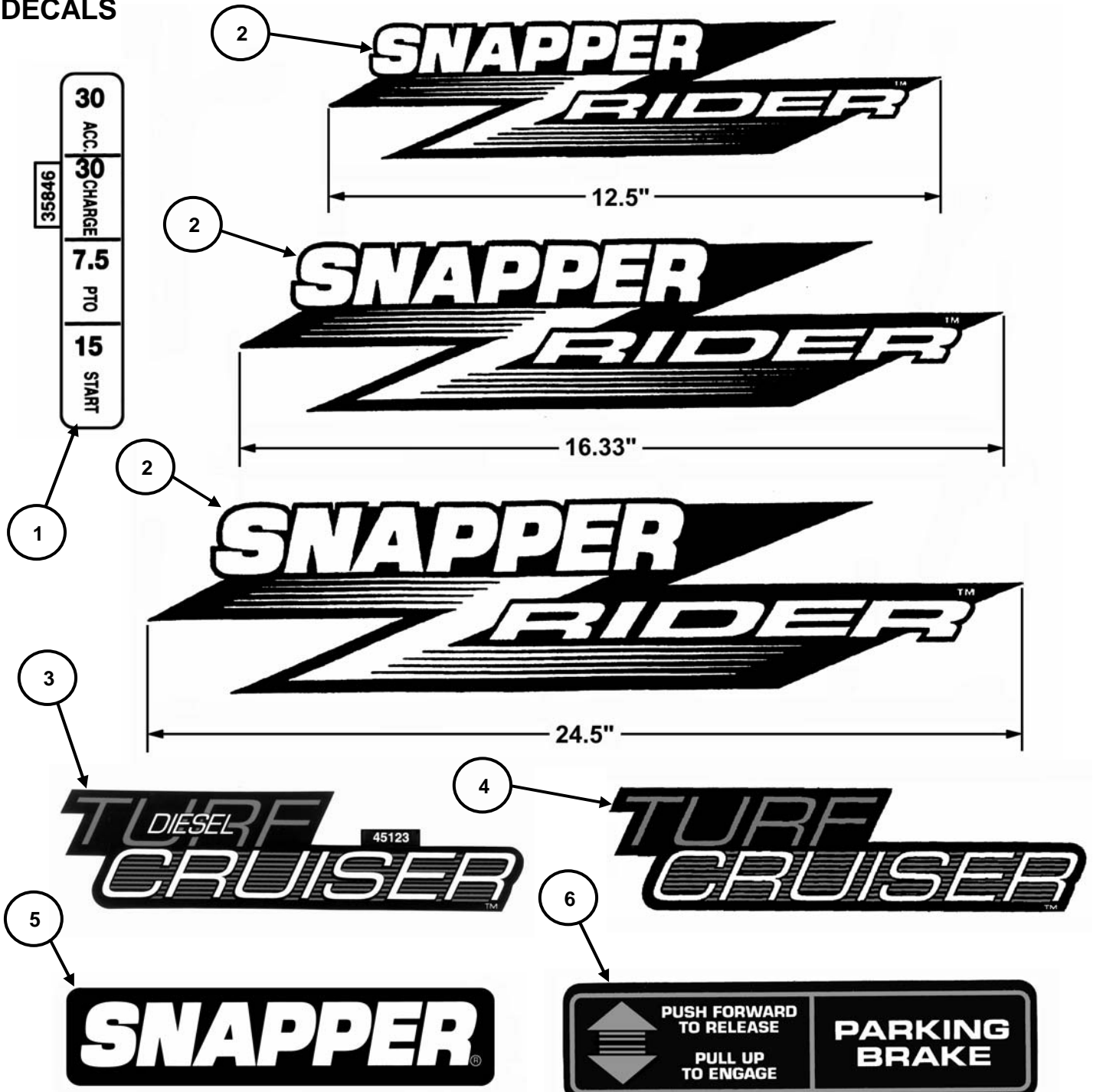

This Product may be covered by one or more of the following patents:

4,158,279	4,164,112
4,189,903	4,248,034
4,430,848	4,498,552
4,920,733	4,936,886
4,989,400	5,042,241
5,146,735	5,195,308
5,297,379	5,303,534
5,353,581	5,488,818
5,526,635	D358,400
Other Patents Pending.	29470

ITEM	PART NO.	DESCRIPTION
1	3-5846	DECAL, Fuse
2	4-5347	DECAL, Snapper Z-Rider (12-1/2" Long)
--	3-5848	DECAL, Snapper Z-Rider (16.33" Long)
--	3-5847	DECAL, Snapper Z-Rider (24-1/2" Long)
3	4-5123	DECAL, Turf Cruiser- OFD (Model ZF2100DKU)
4	4-4677	DECAL, Turf Cruiser- OFG (Model ZF2300GKU)
5	4-4640	DECAL, Snapper
6	4-5107	DECAL, Parking Brake
7	2-9470	DECAL, Patent Numbers

8

5
4
3
2

73602

SNAPPER RIDER

WARNING
BEFORE OPERATING
READ OPERATORS
MANUAL AND
SAFETY INSTRUCTIONS

UP
DECK
LIFT
DOWN

10

13

12

29776

11

14

15

17

16

73433

ITEM	PART NO.	DESCRIPTION
8	7-3602	DECAL, Instrument Panel OFD (replaces 4-6191)
9	2-9295	DECAL, Height-of-Cut
10	7-2247	DECAL, Height-of-Cut (Euro)
11	1-3010	DECAL, Warning (CPSC Cut-Finger)
12	7-3596	DECAL, Danger (Rotating Parts)
13	2-9776	DECAL, European Community (EC)
14	4-5348	DECAL, Liquid Cooled Diesel
15	7-2195	DECAL, Liquid Cooled
16	7-3433	DECAL, 2001 Year of Manufacture
17	7-2253	DECAL, Diesel Fuel

DECALS

⚠ WARNING

TO AVOID SERIOUS INJURY OR DEATH

- READ OPERATOR'S MANUAL AND OTHER INSTRUCTIONAL MATERIALS PROVIDED.
- KNOW LOCATION AND FUNCTION OF ALL CONTROLS.
- NEVER START BLADES UNLESS PROPERLY SEATED ON MACHINE.
- KEEP SAFETY DEVICES (GUARDS, SHIELDS AND SWITCHES) IN PLACE.
- REMOVE OBJECTS THAT COULD BE THROWN BY THE BLADES.
- DO NOT MOVE MOTION CONTROL LEVERS RAPIDLY. AVOID SUDDEN TURNS.
- DO NOT OPERATE BLADES IN REVERSE.
- LOOK DOWN AND BEHIND BEFORE AND DURING REVERSE MOVEMENT.
- DO NOT MOW IN ANY AREA WHERE STABILITY AND TRACTION IS IN DOUBT. DO NOT MOW ON SLOPES STEEPER THAN 15°.
- REDUCE SPEED ON SLOPES. GO FORWARD DOWN SLOPES. GO REVERSE UP SLOPES. NEVER TRAVEL ACROSS SLOPES.
- AVOID UPHILL STARTS. IF MACHINE STOPS GOING UPHILL, STOP BLADES AND BACK DOWN SLOWLY.
- DO NOT MOW WHEN CHILDREN OR OTHERS ARE AROUND. NEVER CARRY CHILDREN DURING OPERATION EVEN WITH BLADES OFF.
- BE SURE ALL MOVING PARTS ARE STATIONARY BEFORE PLACING HANDS AND FEET NEAR BLADES OR SERVICING MACHINE.

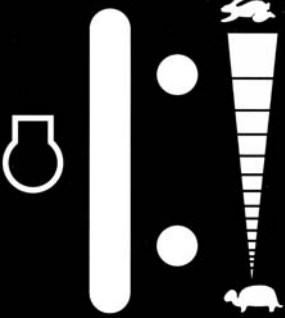

TO START:
MAKE SURE OPERATOR IS SEATED PROPERLY.
PLACE MOTION CONTROL LEVERS IN CENTER/NEUTRAL POSITION.
PULL UP ON BRAKE LEVER TO SET BRAKE.
PUSH BLADE SWITCH DOWN TO MAKE SURE BLADE IS DISENGAGED.
SET THROTTLE TO SLOW SPEED.
TURN KEY TO START ENGINE.

TO OPERATE:
ADJUST THROTTLE TO FULL SPEED.
PULL BLADE SWITCH UP TO ENGAGE BLADE.
PUSH PARKING BRAKE LEVER DOWN TO RELEASE BRAKE.
MOVE MOTION CONTROL LEVERS IN THE DIRECTION OF TRAVEL REQUIRED.
INCREASE / DECREASE SPEED WITH AMOUNT OF MOTION CONTROL LEVERS TRAVEL FROM CENTER / NEUTRAL POSITION.

TO STOP:
MOVE MOTION CONTROL LEVERS TO CENTER / NEUTRAL POSITION.
PUSH BLADE SWITCH DOWN TO DISENGAGE BLADE.
PULL UP ON BRAKE LEVER TO SET BRAKE.
TURN KEY TO OFF POSITION AND REMOVE.
MAKE SURE ALL MOVEMENT HAS STOPPED BEFORE DISMOUNTING. 73600

18

⚠ CAUTION ⚠

DO NOT OPERATE MOWER WITHOUT CHUTE DEFLECTOR OR COMPLETE GRASS CATCHER ASSEMBLY IN POSITION. DO NOT REMOVE GRASS CATCHER OR RAISE CHUTE DEFLECTOR UNTIL ENGINE AND BLADE(S) HAVE STOPPED.

22522

19

24

23



De machine niet gebruiken zonder de grasopvangzak of de beschermkap.

Do not operate without entire Grass Catcher or Guard in place.

Ne pas utiliser sans le bac de ramassage ou la protection en place.

Betreiben sie dieses gerät nicht ohne grasfängkorb oder abdeckschutz.

20

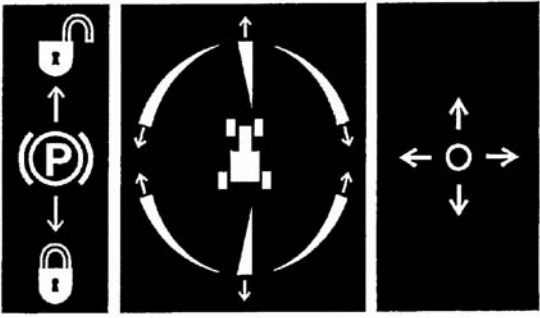



21

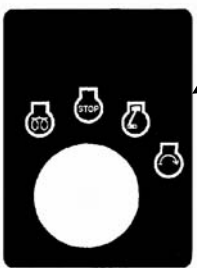

22

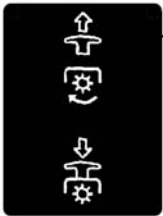

25

ITEM	PART NO.	DESCRIPTION
18	7-3600	DECAL, Throttle (shown)
--	7-3601	DECAL, Throttle w/choke (not shown)
--	4-4935	DECAL, Throttle Control (voided) (not shown)
--	3-5844	DECAL, Throttle Control (not shown)
19	2-2522	DECAL, Caution
20	4-4793	DECAL, Deck Size 52"
21	4-4794	DECAL, Deck Size 61"
22	7-2307	DECAL, Key Switch
23	7-2254	DECAL, Joystick Operation
24	7-2748	DECAL, Warning 4 Language (shown)
--	7-2916	DECAL, Warning (Span/Ital/Port/Eng) (not shown)
--	7-2917	DECAL, Warning (Swedish/Danish/Finnish/Norwegian) (not shown)
25	7-2747	DECAL, PTO Switch

DECALS

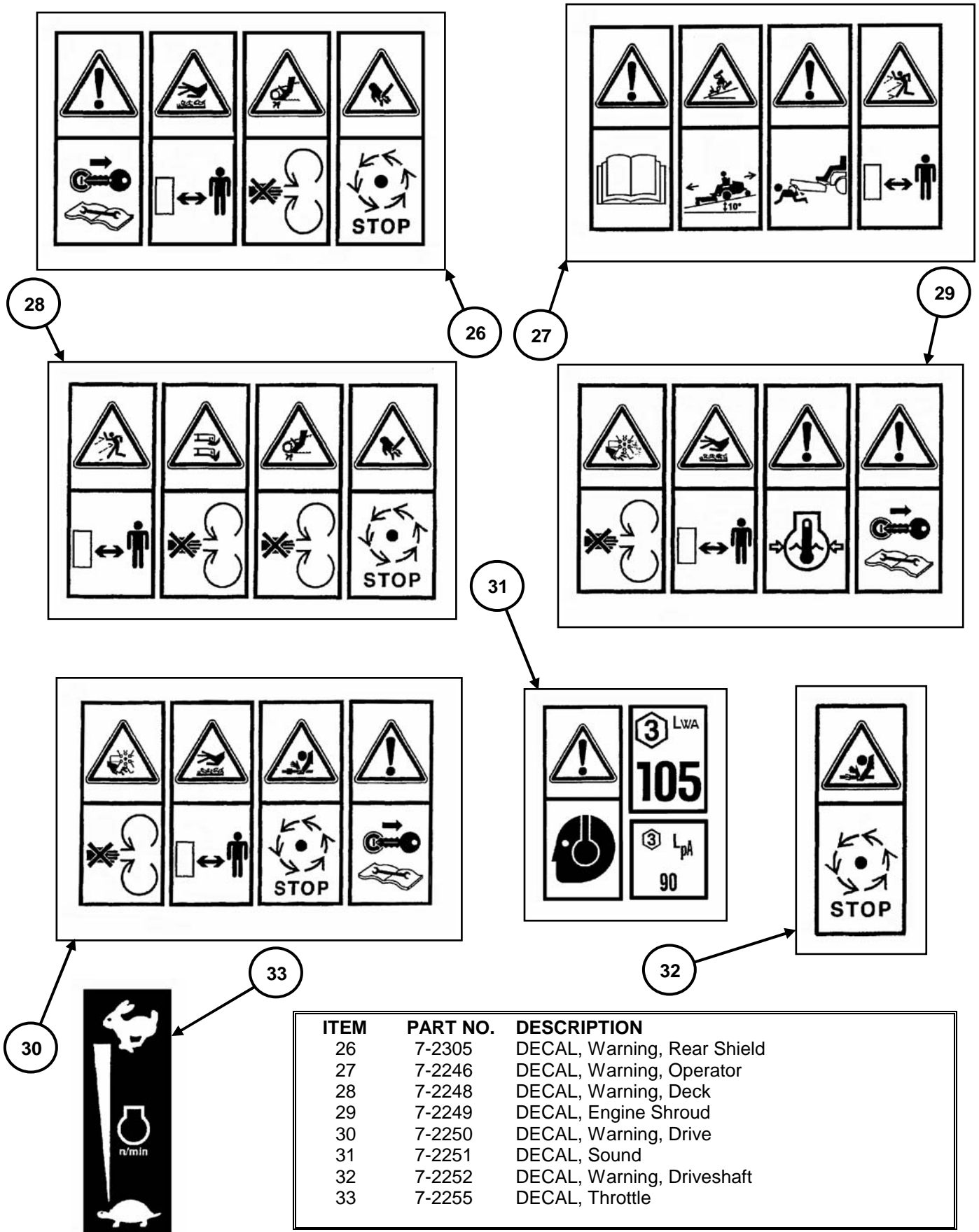

ELECTRICAL COMPONENTS (except wiring)

NOTE:
 THE KEYSWITCH ASSEMBLY (ITEM 1)
 INCLUDES THE FOLLOWING:
 STARTER SWITCH (shown)
 SWITCH KEYS, PAIR (not shown)
 SWITCH LABEL (not shown)
 LOWER RUBBER BOOT (not shown)
 UPPER RUBBER COVER (not shown)

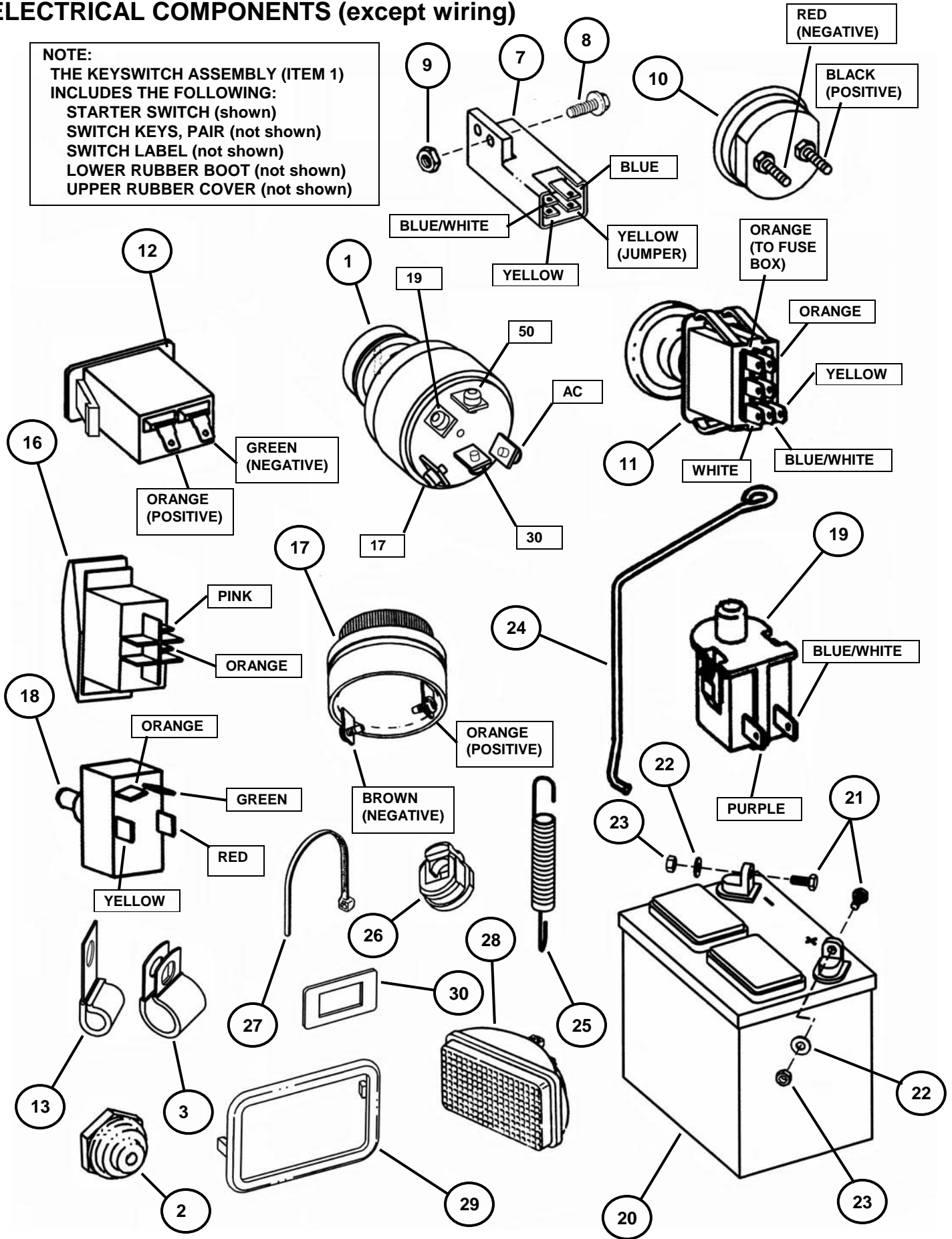

ELECTRICAL COMPONENTS (except wiring)

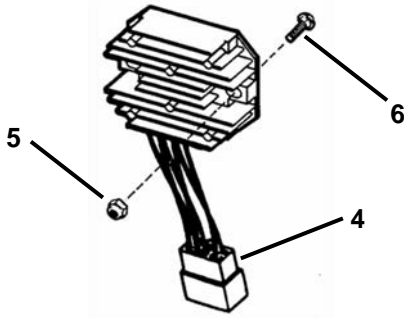

ITEM	PART NO.	DESCRIPTION
1	4-6424	KEYSWITCH, Diesel (Kubota # RC101-53602)
--*	--	KEYSWITCH, Gas (Kubota # 12581-55121)
2	3-5702	SEAL, Switch
3	1-5861	CLIP, Harness
4*	--	REGULATOR (Kubota Part No. RP201-53711)
5	9-1603	NUT, 1/4-20 Hex Nyloc (2)
6	9-1321	BOLT, 1/4-20 x 1" Short Square Neck Carriage (2)
7	4-5345	SWITCH, DPDT, NO/NO
8	9-1240	SCREW, #10-32 x 5/8" Hex Wash. Hd. Machine, Grade 5 (2)
9	9-0376	NUT, #10-32 Hex Nyloc (2)
10	1-9547	ASSEMBLY, Ammeter and Clamp
11	2-8542	SWITCH, PTO
12	4-5281	HOUR METER, D.C.
13	3-5638	CLIP, Open J, 3/8" Cushioned
14	9-1523	SCREW, 5/16-18 x 5/8" Hex Washer Self-Tap (2)
15	9-0585	NUT, 5/16-18 Hex Flange Lock, Grade 5
16	3-5659	SWITCH, Lights
17	7-9208	BUZZER, Pulsing
18	3-5700	SWITCH, Self Centering, Deck Lift
19	1-5707	SWITCH, Seat NO (see page 22 for illustration)
20	3-5610	BATTERY, 11 Plate- 380CCA
21	9-0072	SCREW, 1/4-20 x 5/8", Hex Head Cap, Grade 5 (2)
22	9-0055	WASHER, .28 I.D. x .63 O.D. x .06 Flat (2)
23	9-0372	NUT, 1/4-20 Hex Center Lock, Grade 5 or B (2)
24	2-2366	BRACKET, Battery
25	2-2696	SPRING, Battery
26	3-5779	STRAIN RELIEF, Wire (2)
27	1-2080	CABLE TIE, 7" (15)
28	1-8829	HEAD LIGHT (2)
29	3-5550	BEZEL, Headlight (2)
30	3-5661	SPACER, PTO Switch

***NOTE:**
Order from engine
Manufacturer.

WIRING COMPONENTS (Diesel Only)

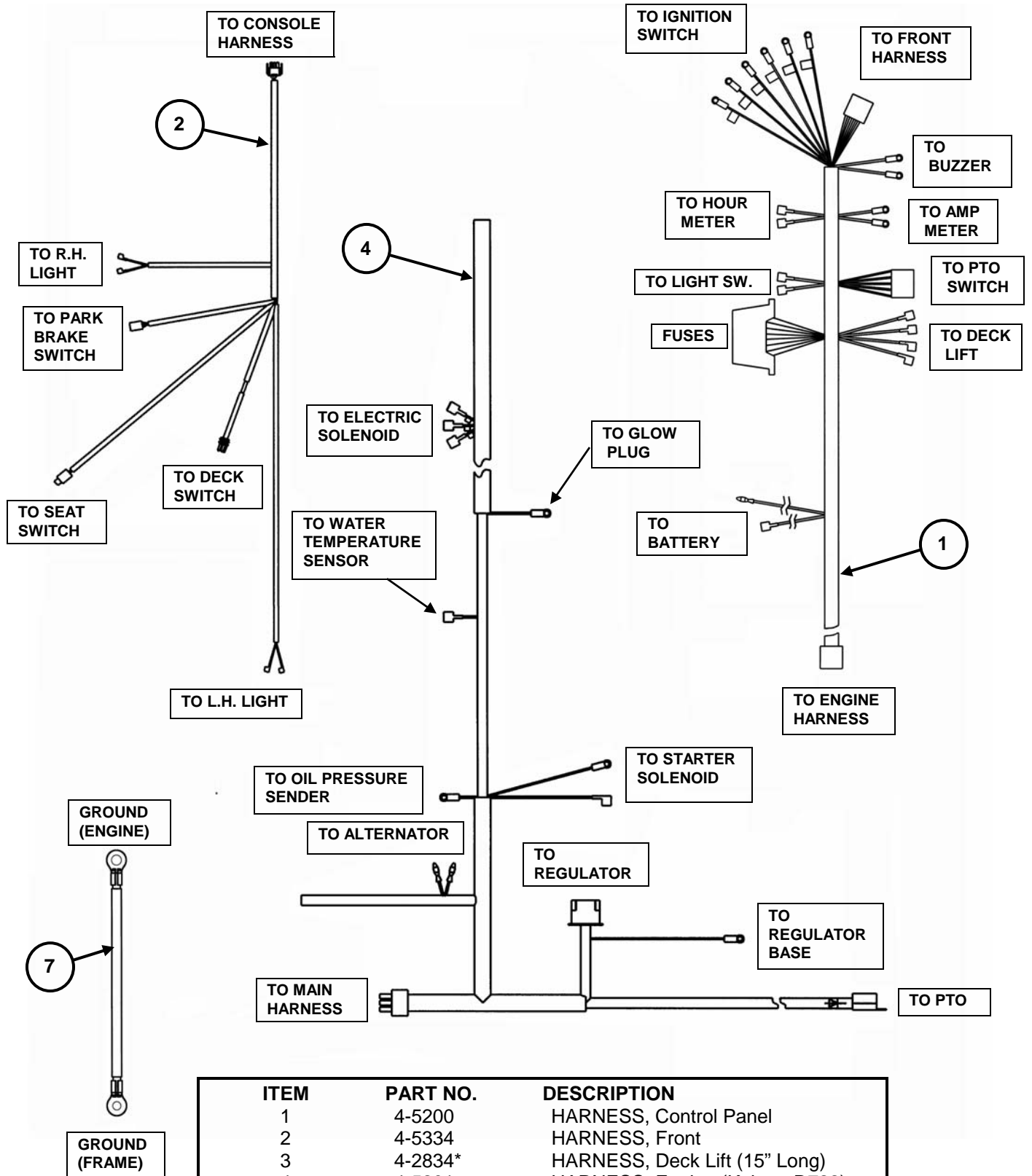

ITEM	PART NO.	DESCRIPTION
1	4-5200	HARNESS, Control Panel
2	4-5334	HARNESS, Front
3	4-2834*	HARNESS, Deck Lift (15" Long)
4	4-5201	HARNESS, Engine (Kubota D722)
5	4-5312*	CABLE, Battery- Positive (51" Long)
6	4-5311*	CABLE, Battery- Ground (38" Long)
7	4-5310	CABLE, Chassis- Ground (15" Long)

*SEE PAGE 48 FOR ILLUSTRATION

WIRING SCHEMATIC (Diesel Only)

NOTE: Switches shown with:
 PARK LEVER in PARK
 PTO in OFF position
 SEAT VACANT

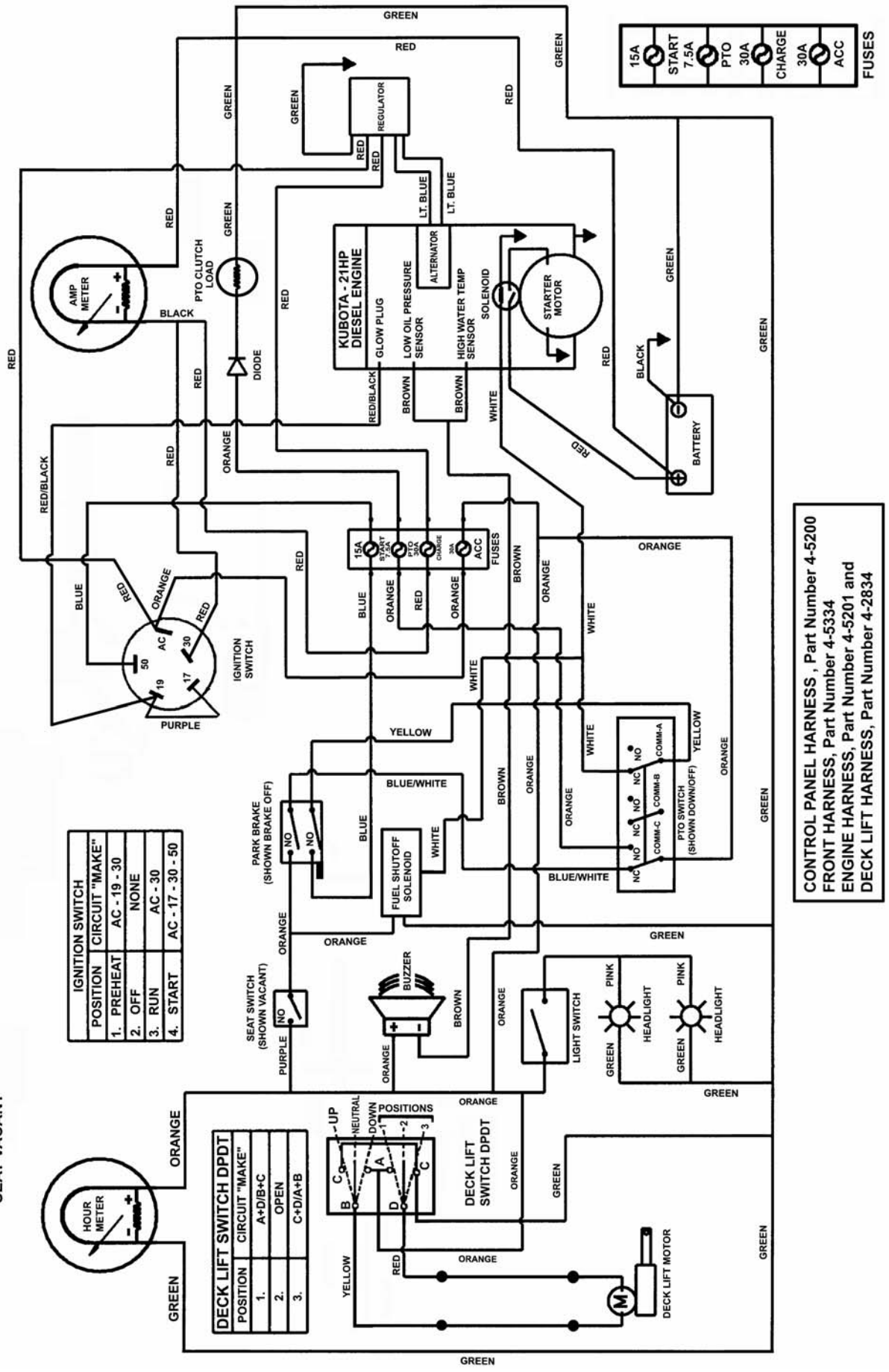

IGNITION SWITCH POSITION	CIRCUIT "MAKE"
1. PREHEAT	AC - 19 - 30
2. OFF	NONE
3. RUN	AC - 30
4. START	AC - 17 - 30 - 50

DECK LIFT SWITCH DPDT POSITION	CIRCUIT "MAKE"
1.	A+D/B+C
2.	OPEN
3.	C+D/A+B

CONTROL PANEL HARNESS, Part Number 4-5200
 FRONT HARNESS, Part Number 4-5334
 ENGINE HARNESS, Part Number 4-5201 and
 DECK LIFT HARNESS, Part Number 4-2834

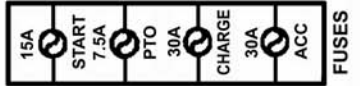

WIRING COMPONENTS (Gas Only)

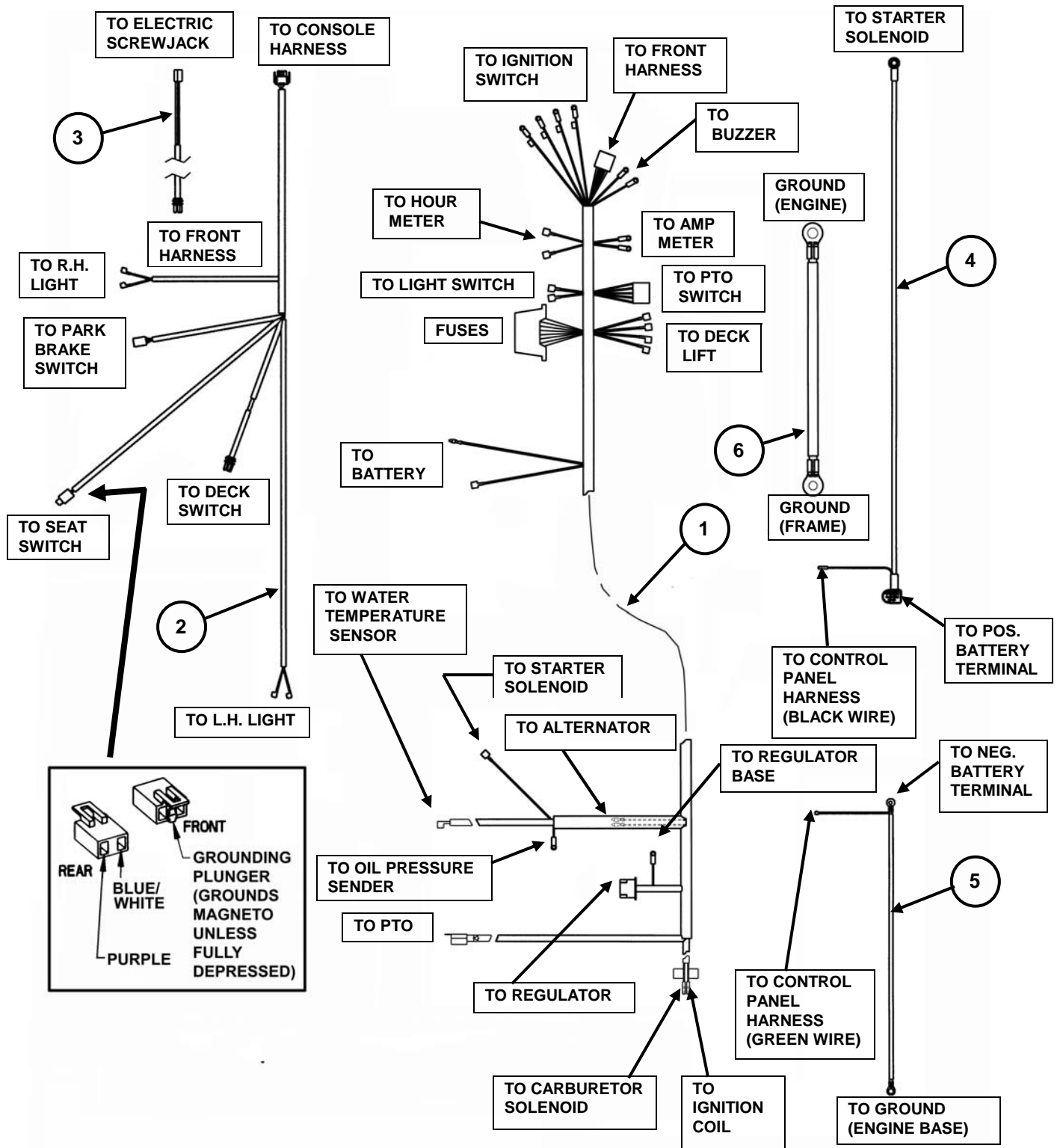

ITEM	PART NO.	DESCRIPTION
1	4-7240	HARNESS, Control Panel
2	4-5334	HARNESS, Front
3	4-2834	HARNESS, Deck Lift (15" Long)
4	4-5312	CABLE, Battery- Positive (51" Long)
5	4-5311	CABLE, Battery- Ground (38" Long)
6	5-8364	CABLE, Chassis- Ground (18" Long)

WIRING SCHEMATIC (Gas Only)

NOTE: Switches shown with:
 PARK LEVER in PARK
 PTO in OFF position
 Seat Vacant

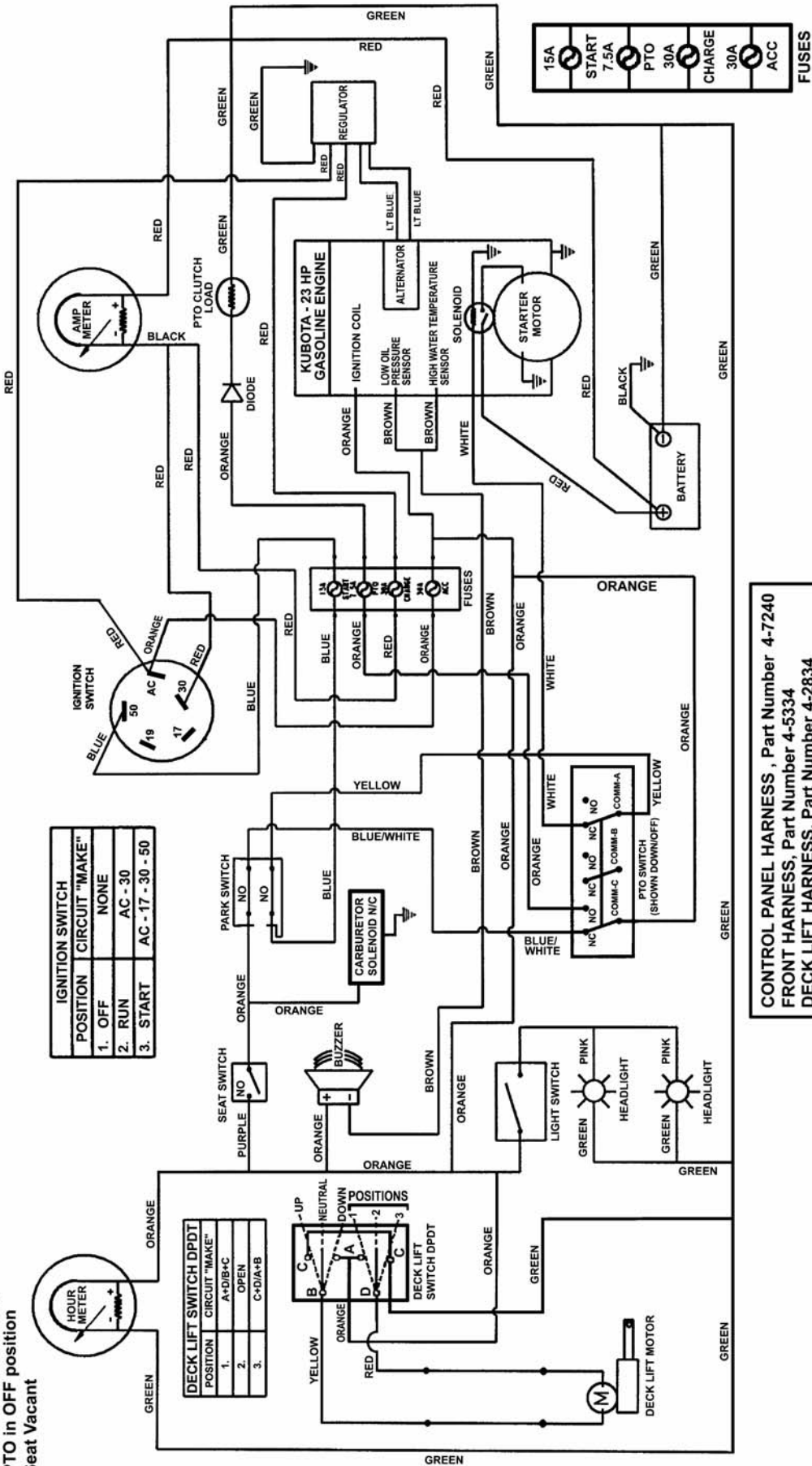

CONTROL PANEL HARNESS, Part Number 4-7240
 FRONT HARNESS, Part Number 4-5334
 DECK LIFT HARNESS, Part Number 4-2834

Parts Manual for

SNAPPER[®]

OUT FRONT Z-RIDER[™]

ZERO TURNING HYDRO DRIVE

KUBOTA SERIES 0

POWER UNIT MODELS

EZF2100DKU

ZF2100DKU

ZF2300GKU

MOWER UNIT MODELS

ZF6100M

EZF6100M

ZF5200M

EZF5200M

IT IS THE POLICY OF SNAPPER TO IMPROVE ITS PRODUCTS WHENEVER IT IS POSSIBLE AND PRACTICAL TO DO SO. WE RESERVE THE RIGHT TO MAKE CHANGES OR ADD IMPROVEMENTS AT ANY TIME WITHOUT INCURRING ANY OBLIGATION TO MAKE SUCH CHANGES ON PRODUCTS MANUFACTURED PREVIOUSLY.

SNAPPER[®] McDonough, GA., 30253 U.S.A.

COPYRIGHT © 2002
SNAPPER INC.
ALL RIGHTS RESERVED