

Safety Instructions & Operator's Manual for **SNAPPER**[®]

EUROPEAN 21" CAST ALUMINUM DECK WALK MOWERS COMMERCIAL MODEL SERIES 2



SELF-PROPELLED MODEL
ECLP21602KWV

MODEL NUMBER EXPLANATION

E	C	L	P	21	60	2	KWV
---	---	---	---	----	----	---	-----

MODEL DESIGNATION _____

SELF-PROPELLED _____

CUTTING WIDTH _____

ENGINE OPTIONS _____

SERIES DESIGNATION _____

ENGINE HORSE POWER *

E – European Model	
C – Commercial Model	
L – Aluminum Deck	
P – Self Propelled	
21 – 21" Cutting Width	

60 – 6.0 HP (Engine Horse Power)
2 – Series Designation
KW – Kawasaki Engine
V – Over Head Valve Engine

Thank you for buying a SNAPPER Product! Before operating your Walk Behind, read this manual carefully and pay particular attention to the "IMPORTANT SAFETY INSTRUCTIONS" on Pages 2 - 4. Remember that all power equipment can be dangerous if used improperly. Also keep in mind that SAFETY requires careful use in accordance with the operating instructions and common sense!

NOTE: Specifications are correct at time of printing and are subject to change without notice.

* Actual sustained equipment horsepower will likely be lower due to operating limitations and environmental factors.

SNAPPER[®] McDonough, GA., 30253 U.S.A.

COPYRIGHT © 2004
SNAPPER – A DIVISION OF SIMPLICITY MFG., INC.
ALL RIGHTS RESERVED

MANUAL No. 2-9820 (I.R. 8/16/04)



IMPORTANT SAFETY INSTRUCTIONS



WARNING: This powerful cutting machine is capable of amputating hands and feet and can throw objects that can cause injury and damage! Failure to comply with the following SAFETY instructions could result in serious injury or death to the operator or other persons. The owner of the machine must understand these instructions and must allow only persons who understand these instructions to operate machine. Each person operating the machine must be of sound mind and body and must not be under the influence of any substance, which might impair vision, dexterity or judgment. If you have any questions pertaining to your machine which your dealer cannot answer to your satisfaction, call or write the Customer Service Department at SNAPPER, McDonough, Georgia 30253. Phone: (1-800-935-2967).

PROTECTION FOR CHILDREN

Tragic accidents can occur if the operator is not alert to the presence of children. Children are often attracted to the machine and the mowing activity. Never assume that children will remain where you last saw them.

1. KEEP children out of the mowing area and under the watchful care of a responsible adult other than the operator.
2. DO NOT allow children in yard when machine is operated and turn machine OFF if anyone enters the area.
3. DO NOT allow pre-teenage children to operate machine.
4. ALLOW only responsible adults & teenagers with mature judgment under close adult supervision to operate machine.
5. DO NOT pull mower backwards unless absolutely necessary. LOOK and SEE behind and down for children, pets and hazards before and while backing.
6. USE EXTRA CARE when approaching blind corners, shrubs, trees, or other objects that may obscure vision.

SLOPE OPERATION

1. Slopes are a major factor related to slip and fall accidents, which can result in severe injury. All slopes require extra caution. If you feel uneasy on a slope, DO NOT mow it.
2. Mow across slopes, never up-and-down. Exercise extreme CAUTION when changing directions on slopes. DO NOT mow steep slopes or other areas where stability or traction is in doubt.
3. Use extra care with grass catchers or other attachments; these affect the handling and the stability of the machine.

PREPARATION

1. Read, understand, and follow instructions and warnings in this manual and on the mower, engine and attachments. Know the controls and the proper use of the mower before starting.
2. Only mature, responsible persons shall operate the machine and only after proper instruction.

PREPARATION

(Continued From Previous Column)

3. Data indicates that operators age 60 and above, are involved in a large percentage of mower-related injuries. These operators should evaluate their ability to operate the mower safely enough to protect themselves and others from serious injury.
4. Handle fuel with extra care. Fuels are flammable and vapors are explosive. Use only an approved fuel container. DO NOT remove fuel cap or add fuel with engine running. Add fuel outdoors only with engine stopped and cool. Clean spilled fuel and oil from machine. DO NOT smoke.
5. Check the area to be mowed and remove all objects such as toys, wire, rocks, limbs and other objects that could cause injury if thrown by blade or interfere with mowing. Also note the location of holes, stumps, and other possible hazards.
6. Keep people and pets out of the mowing area. Immediately, STOP Blade, Stop engine and Stop mower if anyone enters the area.
7. Check shields, deflectors, switches, blade controls and other safety devices frequently for proper operation and location.
8. Make sure all safety decals are clearly legible. Replace if damaged.
9. Protect yourself when mowing and wear safety glasses, long pants and substantial footwear. DO NOT mow barefooted or with sandals.
10. Know how to STOP blade and engine quickly in preparation for emergencies.
11. Use extra care when loading or unloading the machine into a trailer or truck.
12. Check grass catcher components frequently for signs of wear or deterioration and replace as needed to prevent injury from thrown objects going through weak or torn spots.

SAFE HANDLING OF GASOLINE

To avoid personal injury or property damage, use extreme care in handling gasoline. Gasoline is extremely flammable and the vapors are explosive

1. Extinguish all cigarettes, cigars, pipes and other sources of ignition.
2. Use only an approved fuel container.



IMPORTANT SAFETY INSTRUCTIONS



SAFE HANDLING OF GASOLINE

(Continued From Previous Page)

3. DO NOT remove fuel cap or add fuel with the engine running. Allow the engine to cool before refueling.
4. DO NOT refuel the machine indoors.
5. DO NOT store the machine or fuel container inside where there is an open flame, spark or pilot light such as on a water heater or other appliances.
6. DO NOT fill fuel containers inside a vehicle or on a truck or trailer bed with a plastic liner. Always place the containers on the ground away from the vehicle before filling.
7. Remove gas-powered equipment from the vehicle or trailer and refuel it on the ground. If this is not possible, then refuel equipment using a portable container, rather than a gasoline dispenser nozzle.
8. DO NOT start gas powered equipment in enclosed vehicles or trailers.
9. Keep the nozzle in contact with the rim of the fuel tank or container opening at all times until fueling is complete. DO NOT use a nozzle lock-open device
10. If fuel is spilled on clothing, change clothing immediately.
11. DO NOT overfill a fuel tank. Replace fuel cap and tighten securely.

OPERATION

1. DO NOT put hands or feet near or under rotating parts. Keep clear of discharge area while engine is running.
2. STOP engine when crossing gravel drives, walks, or roads, and under any conditions where thrown objects might be a hazard.
3. Mow only in daylight or good artificial light.
4. DO NOT operate mower while under the influence of alcohol or drugs.
5. After striking a foreign object or if mower vibrates abnormally, STOP the engine, disconnect and secure spark plug wire. Inspect the mower for any damage and repair the damage before starting.
6. DO NOT mow near drop offs, ditches or embankments. Operator could lose footing or balance.
7. STAY ALERT for holes and other hidden hazards. Tall grass can hide obstacles. Keep away from ditches, washouts, culverts, fences and protruding objects.
8. DO NOT mow on wet grass. Always be sure of your footing. Keep a firm hold on the handle and walk, never run. Slipping could cause injury.
9. ALWAYS stay behind handle when engine (motor) is running.
10. DO NOT leave the machine with the engine running. STOP BLADE and STOP ENGINE before leaving the operators position for any reason.

OPERATION

(Continued From Previous Column)

11. Before cleaning, repairing or inspecting make certain engine, blade and all moving parts have STOPPED. Disconnect and secure spark plug wire away from plug to prevent accidental starting.
12. STOP engine and wait until the blade comes to complete STOP before removing grass bag and/or clearing grass.
13. DO NOT operate mower without the entire grass catcher, discharge guard, rear guard or other safety devices in place and working. DO NOT point discharge at people, passing cars, windows or doors.
14. DO NOT discharge material against a wall or obstruction. Material may ricochet back towards the operator.
15. Slow down before turning.
16. Watch out for traffic when near or crossing roadways.
17. DO NOT operate engine in enclosed areas. Engine exhaust gases contain carbon monoxide, a deadly poison.
18. Only use accessories approved by the manufacturer. See manufacturer's instructions for proper operation and installation of accessories.

MAINTENANCE AND STORAGE

1. DO NOT store mower or fuel container inside where fumes may reach an open flame, spark or pilot light such as in a water heater, furnace, clothes dryer or other gas appliance. Allow engine to cool before storing machine in an enclosure. Store fuel container out of reach of children in a well ventilated, unoccupied building.
2. Keep mower and engine free of grass, leaves or excess grease to reduce fire hazard and engine overheating.
3. When draining fuel tank, drain fuel into an approved container outdoors and away from open flame.
4. Keep all bolts, especially blade bolts, nuts and screws properly tight. Check that all cotter pins are in proper position.
5. Always provide adequate ventilation when running engine. Engine exhaust gases contain carbon monoxide, a deadly poison.
6. Service engine and make adjustments only when engine is stopped. Removed spark plug wire from spark plug and secure wire away from spark plug to prevent accidental starting.
7. DO NOT change engine governor speed settings or overspeed engine.
8. Check grass bag assembly frequently for wear or deterioration to avoid thrown objects and exposure to moving parts. Replace with new bag if loose seams or tears are evident. Replace slider or bag adapter if broken or cracked.



IMPORTANT SAFETY INSTRUCTIONS



MAINTENANCE AND STORAGE

(Continued From Previous Page)

9. Mower blades are sharp and can cut. Wrap the blades or wear heavy leather gloves and use CAUTION when handling them.
10. DO NOT test for spark by grounding spark plug next to spark plug hole; spark plug could ignite gas exiting engine.
11. Have machine serviced by an authorized SNAPPER dealer at least once a year and have the dealer install any new safety devices.
12. Use only genuine SNAPPER replacement parts to assure that original standards are maintained.

TABLE OF CONTENTS

IMPORTANT SAFETY INSTRUCTIONS	2-4
TABLE OF CONTENTS.....	5
SECTION 1 - FAMILIARIZATION.....	6
SECTION 2 - OPERATING INSTRUCTIONS	7-9
Pre-start Checklist.....	7
Starting & Stopping Engine & Blades	7
Starting & Stopping Wheel Drive	8
Handle Height Adjustment	8
Cutting Height Adjustment.....	8
Recycling Operation.....	9
Installation of Grass Catcher	9
SECTION 3 - MAINTENANCE INSTRUCTIONS	10-11
Service - After First 5 Hours.....	10-11
Change Engine Oil	10
Check Transmission Grease.....	10
Check Wheel Drive Control	10
Check Mower Blade	11
Check Engine to Transmission Drive Belt.....	11
Service - Annually	11
Engine	11
Air Filter.....	11
Engine Oil.....	11
Storage Procedure	11
SECTION 4 - ADJUSTMENTS AND REPAIR	12-14
Mower Blade Replacement.....	12-13
Blade Sharpening.....	12-13
Wheel Drive Control Adjustment	13
Belt Service	14
TROUBLESHOOTING.....	15
MAINTENANCE SCHEDULE	16
Maintenance/Replacement Parts	16
DECAL IDENTIFICATION	17-19
WARRANTY	20

IMPORTANT

The figures and illustrations in this manual are provided for reference only and may differ from your specific model. Contact your Snapper dealer if you have questions.

Section 1 - FAMILIARIZATION



FIGURE 1.1

1.1 INTRODUCTION

This manual has been prepared for the operators of the SNAPPER WALK BEHIND MOWERS. Its purpose, aside from recommending operating and routine service requirements, is to promote safety through the use of accepted operating practices. **Read, Understand and Follow** the "IMPORTANT SAFETY INSTRUCTIONS" on Pages 2 & 3 of this manual and all safety messages on the mower and attachments before operating the mower.

1.2 NOMENCLATURE

The nomenclature information above, Figure 1.1, shows the essential parts of the SNAPPER WALK BEHIND MOWERS. It is recommended that all operators of the mower become thoroughly familiar with the controls, parts and operation of the mower before operating. Specific details involving the engine are found in the separate engine owner's manual. Study these manuals before operating and keep both handy for future reference.

Section 2 - OPERATING INSTRUCTIONS

2.1 PRE-START CHECK LIST

Make the following checks and perform the service required before each start-up.

2.1.1. Check guards, deflectors, grass bag, adapter and covers to make sure all are in place and securely tightened.

WARNING

DO NOT start or operate this machine without installing the recycling plug or the entire grass catcher.

2.1.2. Check blade control and wheel drive control to insure they work freely. See Figure 2.1.



FIGURE 2.1

2.1.3. Check cutting height. Adjust to desired height.

2.1.4. Check engine oil and add oil as needed to bring level up to the full mark. Refer to Engine Owner's Manual for oil specifications. See Figure 2.2.

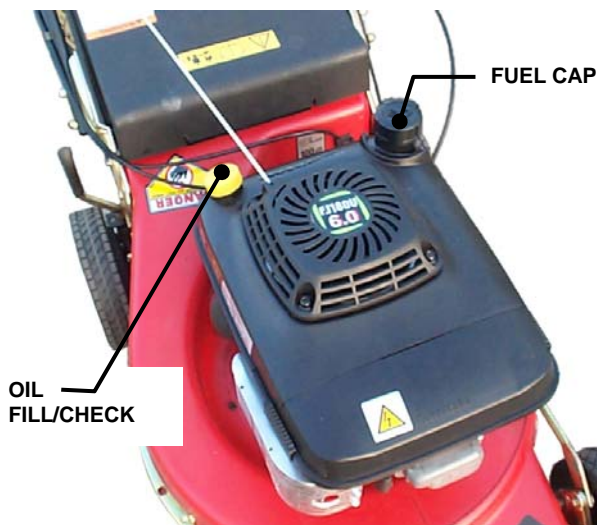

FIGURE 2.2

2.1.5. Add fuel to tank after pushing the mower outside where fumes can safely dissipate. Make sure cap is tightened after refueling. Refer to Engine Owners Manual for specifications.

2.1.6. Clean exterior surfaces of cutting deck and engine of any accumulation of spilled fuel, dirt, grass, oil, etc. Keep engine air intake screen and cooling fins clear at all times.

2.2 STARTING & OPERATION

2.2.1. ENGINE & BLADE

1. Move engine speed control past the "Fast" detent to the "Choke" position. See Figure 2.3.

IMPORTANT: Stop the engine (and blade) by releasing the blade control.

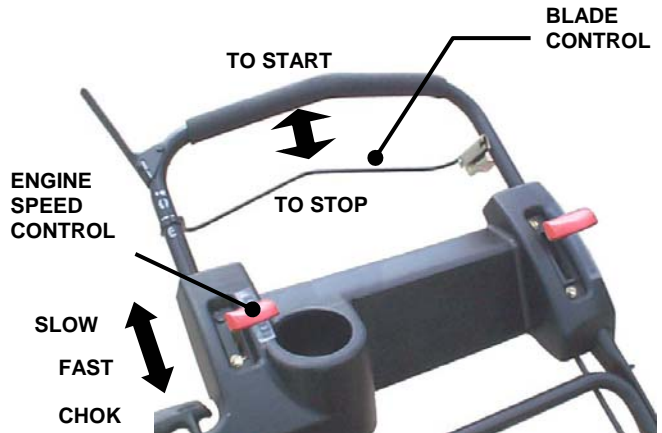

FIGURE 2.3

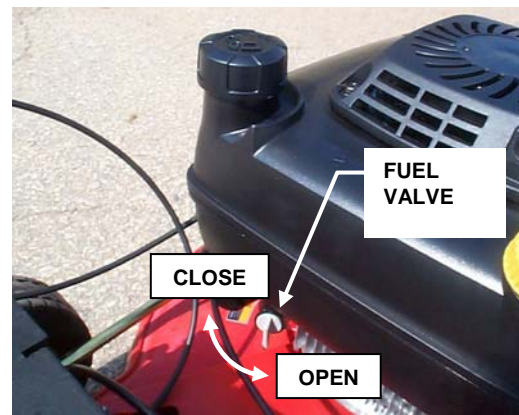

FIGURE 2.4

2. Make sure fuel valve is set to open position. See Figure 2.4.

3. Pull blade control against handle.

4. Pull rope start handle to crank engine.

5. After engine starts, allow a brief warm-up until engine runs smooth, then turn off choke.

Section 2 - OPERATING INSTRUCTIONS

2.2.2. PROPELLING MOWER

1. Move ground speed control to the desired speed position. See Figure 2.5.
2. Move wheel drive control against handle to engage wheel drive and propel mower forward.

IMPORTANT: Forward motion of machine must be stopped before changing position of the ground speed control. See Figure 2.5.



FIGURE 2.5

2.3 STOPPING

Stop engine and blade by releasing the blade control. Stop forward motion of mower by releasing the wheel drive control.

2.4 HANDLE HEIGHT ADJUSTMENT

The height of the mower handle can be adjusted as follows:

1. Loosen the lower nuts on each lower handle as shown in Figure 2.6.

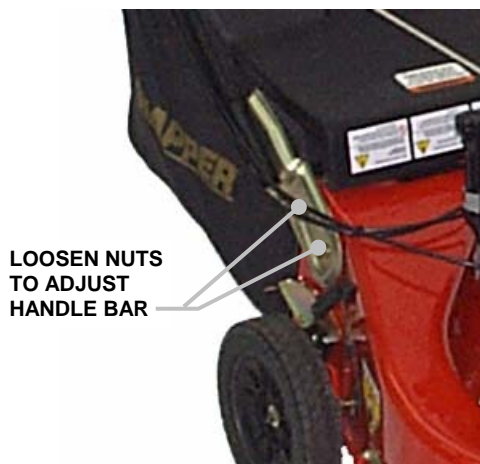

FIGURE 2.6

2. Move upper mower handle up or down until the desired position is achieved.

3. Tighten the nuts on each lower handle bracket to maintain desired position. Torque nuts to 15 to 25 ft. lbs.

WARNING

DO NOT attempt any maintenance, adjustments or service with engine and blade running. **STOP** engine and blade. Remove key. Disconnect spark plug wire and secure away from spark plug. Engine and components are **HOT**. Avoid serious burns, allow sufficient time for all components to cool.

2.5 CUTTING HEIGHT ADJUSTMENT

1. Pull the cutting height adjusting handle outward and move to desired cutting height. See Figure 2.7.

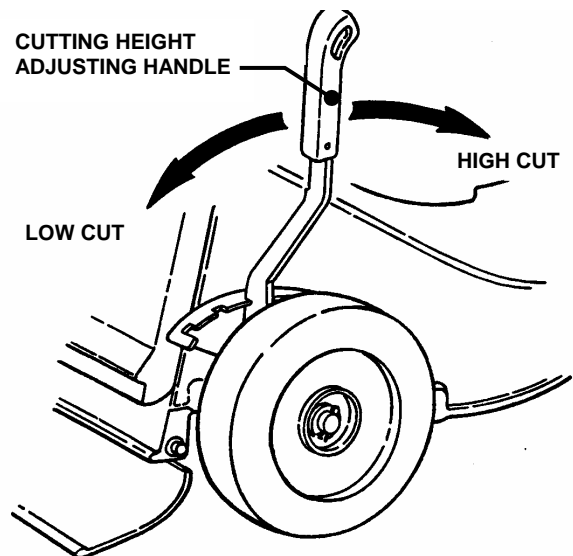

FIGURE 2.7

Section 2 - OPERATING INSTRUCTIONS

2.6 RECYCLING OPERATION

Converting this mower to the recycling operation requires no tools. First, STOP engine. Raise discharge door located at rear of machine. Remove grass catcher. Insert recycling plug fully into discharge opening. Allow discharge door to close. See Figure 2.8.

NOTE: For best recycling results, cut up to a maximum of 1/3 of grass blade length and recycle ONLY when grass is dry.

1. Set the cutting height at the highest cutting position.
2. Move engine speed control to "FAST" (Rabbit) position.
3. Move ground speed control to slowest speed setting.
4. Proceed mowing slowly. If grass is very dense, raise cutting height to improve recycling performance.



FIGURE 2.8

2.7 INSTALLATION of GRASS CATCHER

1. Follow **WARNING** statement found on this page.
2. Lift discharge door located at the rear of machine. See Figure 2.9.
3. Install grass catcher onto the rear of machine. Position the rod ends of catcher frame over the tabs located at the rear of deck. Release discharge door, which is spring loaded, onto top of grass catcher.

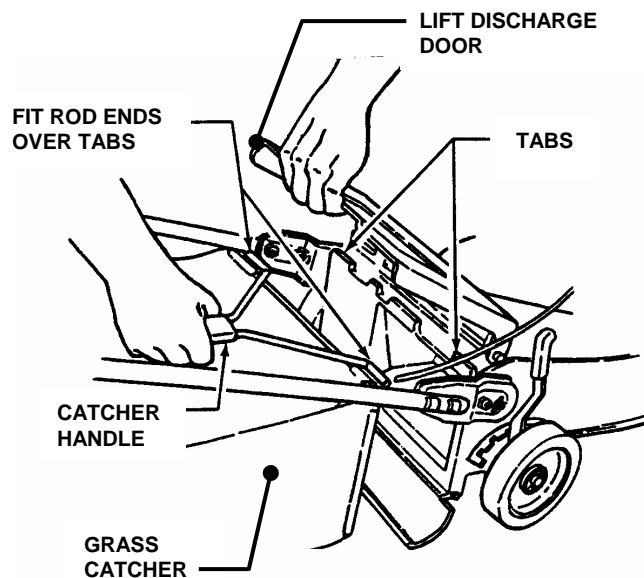





FIGURE 2.9

	WARNING	
<p>DO NOT operate mower without entire grass catcher, side chute or recycling plug in place. Grass Catcher components are subject to deterioration during normal use. Inspect frequently and replace worn or damaged components immediately.</p>		

	WARNING	
<p>Grass Catcher bags used on SNAPPER products are made of woven fabric, and are subject to deterioration and wear during normal usage. Check condition of bag before each use. Immediately replace worn or damaged catcher bags with only bags recommended by SNAPPER. The grass catcher is optional equipment on some models.</p>		

Section 3 - MAINTENANCE

3.1 INTRODUCTION

To retain the quality of the mower, use genuine SNAPPER replacement parts only. Contact a local SNAPPER dealer for parts and service assistance. For the correct part or information for a particular mower, always mention model and serial number.

3.2 SERVICE - AFTER FIRST 5 HOURS

3.2.1. CHANGE ENGINE OIL

	WARNING	
<p>DO NOT attempt any maintenance, adjustments or service with engine and blade running. STOP engine and blade. Remove key. Disconnect spark plug wire and secure away from spark plug. Engine and components are HOT. Avoid serious burns, allow sufficient time for all components to cool.</p>		

NOTE: Due to the location of the oil drain plug, perform the following procedure for the easiest oil change:

1. Disconnect spark plug wire and secure end away from plug. The items needed to perform oil change are: cloth rags and a shallow pan.
2. Tip mower on its side, with the oil fill down. Do not tip mower with spark plug or carburetor down. See Figure 3.1.

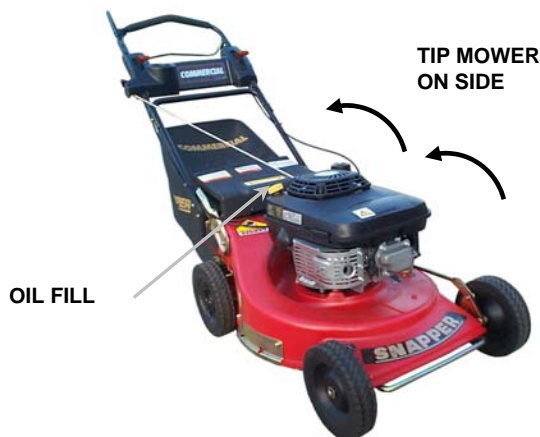

FIGURE 3.1

3. Place shallow pan underneath the approximate center of the oil fill.
4. Remove oil fill cap and allow oil to drain out completely in pan. Some oil may spill onto engine and hands, immediately wipe hands clean with cloth rags. Dispose of oil properly.
5. Tip mower back up.
6. Fill engine with oil as specified in Engine Owner's Manual. Thereafter, change oil after each 25 hours of use.

3.2.2. GREASE LEVEL IN TRANSMISSION

The transmission requires no lubrication or maintenance. If transmission leaks or malfunctions, return machine to an authorized Snapper dealer for repair.

3.2.3. WHEEL DRIVE CONTROL

The wheel drive control requires periodic adjustment to maintain proper drive function. The adjustment is performed with the thumbwheel located on the wheel drive control cable and requires no tools. Refer to Section "WHEEL DRIVE CONTROL ADJUSTMENT".

Section 3 - MAINTENANCE

WARNING

DO NOT attempt any maintenance, adjustments or service with engine and blade running. **STOP** engine and blade. Remove key. Disconnect spark plug wire and secure away from spark plug. Engine and components are **HOT**. Avoid serious burns, allow sufficient time for all components to cool. Wear heavy leather gloves when handling or working around cutting blades. Blades are extremely sharp and can cause severe injury.

3.2.4. CHECK MOWER BLADE

1. Disconnect spark plug wire and secure end away from plug.
2. Tilt mower up on its rear wheels for access to the blade cap screw. See Figure 3.2.

IMPORTANT: DO NOT tip machine with carburetor or spark plug down. Oil from crankcase will saturate the air filter and cause the engine to be hard to start or not start at all. If contamination does occur, the air filter will have to be replaced.

3. Check torque of blade retaining cap screw. Recommended torque should be 30 to 40 ft. lbs. See Figure 3.2.
4. Check blade for sharpness, wear and damage. Refer to Section "BLADE WEAR LIMITS".

3.2.5. CHECK ENGINE to TRANSMISSION DRIVE BELT

1. Visually check belt for cracking, fraying, severed or belt strands exposed. Replace belt before operating mower. Refer to Section "BELT SERVICE" for replacement instructions.

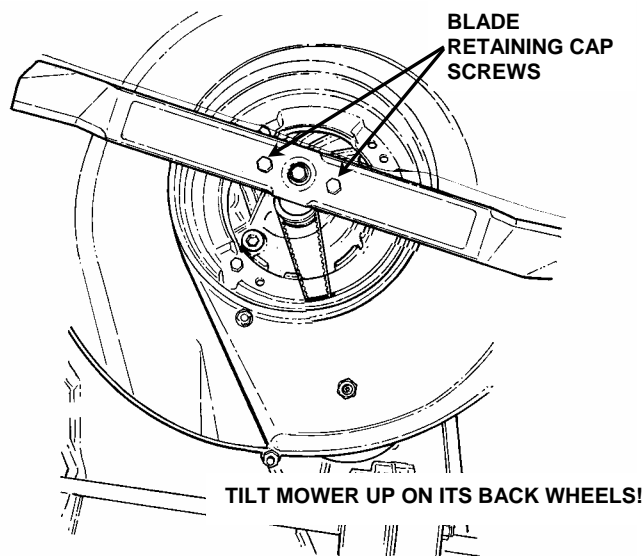

FIGURE 3.2

3.3 SERVICE - ANNUALLY

Perform all maintenance as described in the maintenance schedule.

3.3.1. Engine

Service engine according to engine owner's manual.

3.3.2. Air Filter

Refer to engine owner's manual for service instructions.

3.3.3. Engine Oil

Refer to engine owner's manual for service instructions.

3.4 STORAGE PROCEDURE

Refer to the Engine Owner's Manual for directions regarding engine storage preparations. Prepare the mower for "end of season" storage as follows:

1. Drain fuel from fuel tank and let engine run until all fuel is out of the carburetor.
2. **Disconnect and remove the spark plug wire away from spark plug before any other preparations are made!**
3. Tape all openings closed to prevent spraying water into exhaust or air intakes during washing.
4. Tilt mower up on its rear wheels and thoroughly clean the underside of the deck. Do not tilt mower with spark plug or carburetor down. Scrape away any accumulation of grass with a putty knife and or wire brush.
5. Lubricate all exposed metal with a light coating of oil to prevent corrosion.
6. Loosen handle knobs. Carefully fold the handles forward, "flexing" the control cables to prevent cable damage.
7. Store the mower in a shed or other dry area, protected from weather.

Section 4 - REPAIR & ADJUSTMENTS

WARNING

DO NOT attempt any maintenance, adjustments or service with engine and blade running. STOP engine and blade. Remove key. Disconnect spark plug wire and secure away from spark plug. Engine and components are HOT. Avoid serious burns, allow sufficient time for all components to cool. Wear heavy leather gloves when handling or working around cutting blades. Blades are extremely sharp and can cause severe injury.

4.1 MOWER BLADE REPLACEMENT

4.1.1. STANDARD BLADE WEAR LIMIT

1. Follow **WARNING** statement found on this page.
2. Inspect blade frequently for signs of excessive wear or damage. See Figure 4.1.

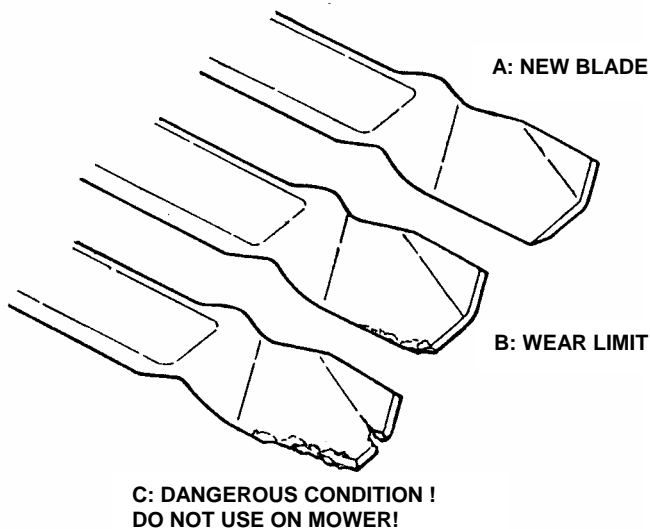

FIGURE 4.1

WARNING

DO NOT use a cutting blade that shows signs of excessive wear or damage. Refer to Section "MOWER BLADE REPLACEMENT" for proper blade inspection and service procedures.

4.1.2. BLADE SHARPENING

1. Follow **WARNING** statement found on this page.
2. Tilt mower up on its rear wheels. Do not tilt mower with spark plug or carburetor down.
3. Remove blade. See Figure 4.2.

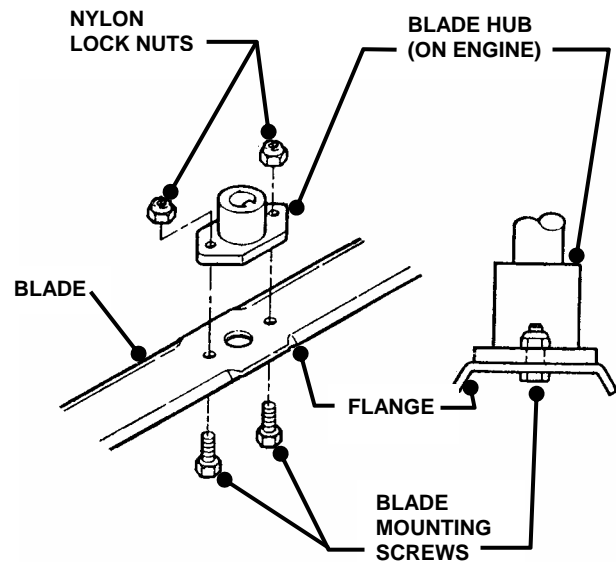

FIGURE 4.2

(Continued on Next Page)

Section 4 - REPAIR & ADJUSTMENTS

WARNING

DO NOT attempt any maintenance, adjustments or service with engine and blade running. STOP engine and blade. Remove key. Disconnect spark plug wire and secure away from spark plug. Engine and components are HOT. Avoid serious burns, allow sufficient time for all components to cool. Wear heavy leather gloves when handling or working around cutting blades. Blades are extremely sharp and can cause severe injury.

4.1 MOWER BLADE REPLACEMENT

4.1.2. BLADE SHARPENING

(Continued From Previous Page)

4. Sharpen blade on a grinding wheel at an angle of 22 to 28 degrees. DO NOT sharpen blade beyond original cutting edge. See Figure 4.3.

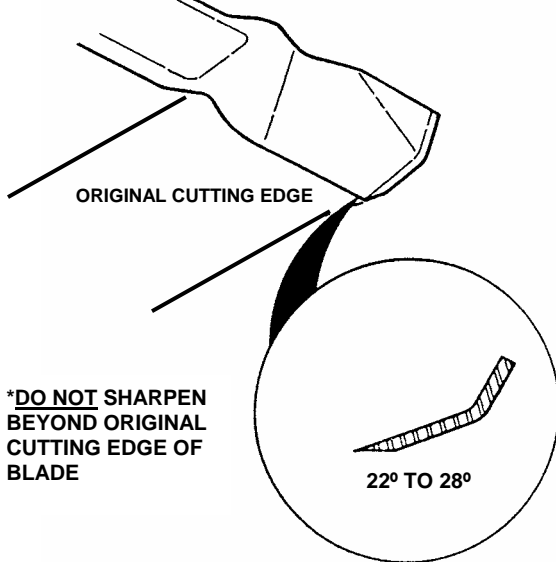

FIGURE 4.3

5. Check blade for balance. If necessary, correct balance by grinding heavy end of blade.
6. Reinstall blade. See Figures 4.2 & 4.3. Check torque of blade retaining cap screw. Recommended torque should be 30 to 40 ft. lbs.

4.2 WHEEL DRIVE CONTROL ADJUSTMENT (Engine To Transmission Drive Belt)

The wheel drive control requires periodic adjustment to maintain proper engine to transmission drive belt tension. The adjustment is located on the right handle and requires no tools. See Figure 4.4.

IMPORTANT: DO NOT operate engine when inspecting or adjusting the drive belt.

1. Visually check engine drive belt for cracking, fraying, severed or belt strands exposed. Replace belt before operating mower.
2. To check for proper drive belt tension. STOP engine. Shift ground speed control to 1st and engage the wheel drive control.
3. With the wheel drive control engaged, pull the mower handles, moving the mower rearward. Observe the rear wheels.
4. If the rear wheels slide on the surface (no rotation) the belt is properly tensioned and the control does not require adjustment.
5. If the rear wheels rotate, increase belt tension by rotating the thumb screw COUNTER-CLOCKWISE.
6. Turn thumb screw one turn at a time and recheck tension (repeating steps 3-5).
7. When proper belt tension has been set, operate machine and verify proper wheel drive control function.

IMPORTANT: DO NOT over-tighten wheel drive control. DO NOT operate if control or drive does not function properly. Contact your local SNAPPER Dealer for assistance.

IMPORTANT: If machine creeps forward after wheel drive control is released the cable is too tight and must be readjusted to eliminate all forward movement. Machine must not have any forward movement when wheel drive control is disengaged. If the wheel drive control fails to return quickly to the "OFF" position when released, check for a broken, binding, or kinked cable.

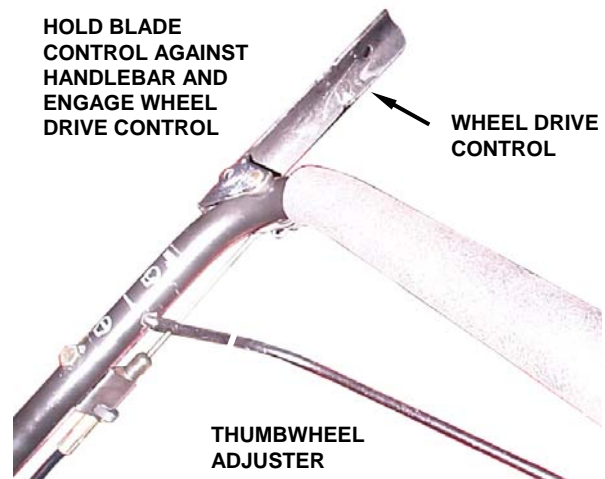

FIGURE 4.4

Section 4 - REPAIR & ADJUSTMENTS



WARNING



DO NOT attempt any maintenance, adjustments or service with engine and blade running. STOP engine and blade. Remove key. Disconnect spark plug wire and secure away from spark plug. Engine and components are HOT. Avoid serious burns, allow sufficient time for all components to cool. Wear heavy leather gloves when handling or working around cutting blades. Blades are extremely sharp and can cause severe injury.

4.3 BELT SERVICE

The condition of the engine to transmission belt should be checked after every 25 hours of mower operation.

4.3.1. Engine To Transmission Belt Replacement

1. Follow **WARNING** statement found on this page.
2. Remove the retaining screws that secure the belt cover. Remove the belt cover. See Figure 4.5
3. Disconnect belt from transmission pulley.
4. Tilt mower up on its rear wheels. Do not tilt mower with spark plug or carburetor down.
5. Remove the retaining bolts and nuts that secure the blade. Remove blade. See Figure 4.5.
6. Remove the belt from around engine pulley.
7. Install the new belt from around engine pulley. Insert belt through opening in deck.
8. Secure the blade with retaining bolts and nuts. Tighten nuts and bolts to 30 to 40 ft. lbs.
9. Install new belt over transmission pulley. Install belt cover and secure with retaining bolts. Tighten securely.

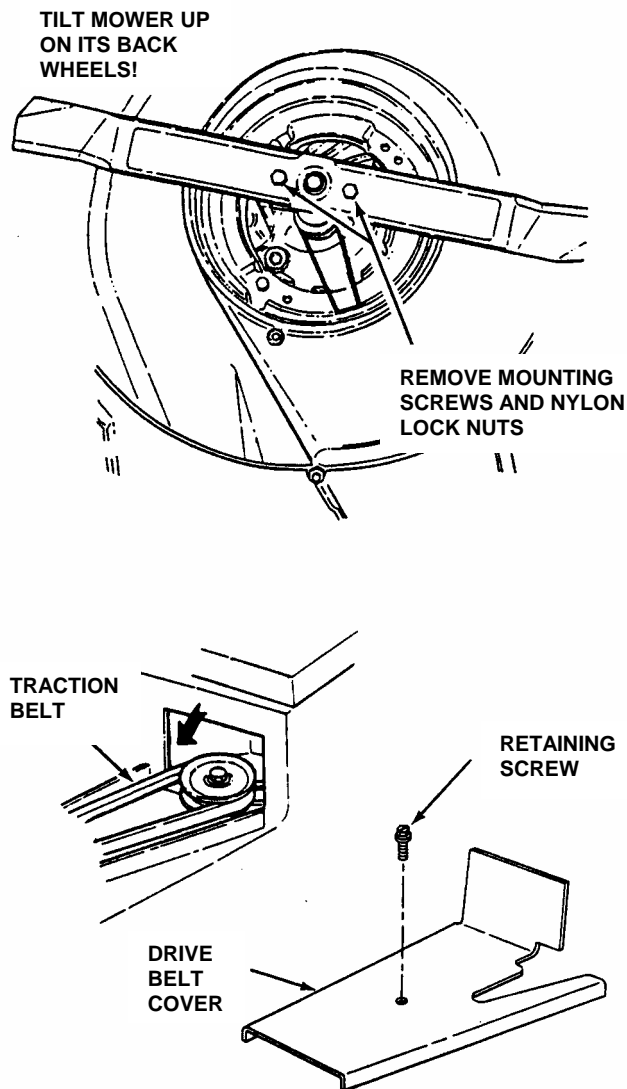

FIGURE 4.5

TROUBLESHOOTING

PROBLEM	PROBABLE CAUSE	CORRECTIVE ACTION
Engine Will Not Start Using Recoil Starter	1. Fuel tank empty.	1. Fill fuel tank with fresh fuel.
	2. Engine requires choking.	2. Choke engine.
	3. Spark plug wire disconnected.	3. Place spark plug wire onto spark plug.
Engine Stalls or Stops After Running	1. Blade control is released or is not being held securely against handle.	1. Blade control should be held securely against handle at all times during operation of mower.
	2. Fuel tank empty.	2. Fill with fuel to proper level.
	3. Engine air pre-cleaner and or air cleaner dirty.	3. Clean free of all debris.
	4. Spark plug defective or gap set improperly.	4. Service spark plug.
	5. Water, debris or stale fuel in fuel system.	5. Drain and clean fuel system.
	6. Choke on.	6. Turn off choke.
Engine Loses Power	1. Engine air pre-cleaner or air cleaner dirty.	1. Clean or replace filters.
	2. Spark plug faulty.	2. Service spark plug.
	3. Water, debris or stale fuel in fuel system.	3. Drain and clean fuel system.
	4. Debris build up on engine cooling screen.	4. Clean all debris from engine cooling screen.
	5. Choke on.	5. Turn off choke.
Excessive Vibration	1. Damaged, out of balance or bent mower blade.	1. Service mower blade.
	2. Loose blade components.	2. Service and tighten loose parts.
	3. Loose or missing air lift (if equipped).	3. Replace air lifts. Tighten to proper torque.
	4. Lumpy or frayed belt.	4. Replace belt.
Mower Will Not Move Or Loss Of Traction (Self-Propelled Models)	1. Damaged transmission.	1. Contact authorized SNAPPER dealer.
	2. Traction drive belt requires replacement or adjustment.	2. Replace/Adjust traction drive belt.
	3. Insufficient lubrication in transmission/differential.	3. Contact authorized SNAPPER dealer.
Cutting Grass Improperly	1. Cutting height too low or high.	1. Adjust cutting height.
	2. Engine speed too slow.	2. Move engine speed control to "FAST" position.
	3. Forward ground speed too fast.	3. Move ground speed control to a slower speed.
	4. Cutting blade dull or damaged.	4. Sharpen cutting edges or replace blade.
Poor Grass Discharge	1. Engine speed too slow.	1. Move engine speed control to "FAST" position.
	2. Forward speed too fast.	2. Move ground speed control to a slower speed.
	3. Grass is wet.	3. Mow when grass is dry.
	4. Excessively worn or damaged blade.	4. Service mower blade.
	5. Build up of grass clippings and debris under deck.	5. Clean underside of deck.
	6. Improper blade installed on deck.	6. Install proper SNAPPER blade.
	7. Blade installed improperly on deck.	7. Install blade properly.
Oil Leaking	1. Leaking engine block.	1. Check and tighten oil drain plug 2. Make sure dip stick or oil filler cap is securely in place. 3. Contact authorized SNAPPER dealer.

MAINTENANCE SCHEDULE

ITEM	SERVICE PERFORMED	REF.	EACH USE	5 HRS	25 HRS	50 HRS	100 HRS	EACH SEASON
Engine Oil	Check Oil Level	Page 7	X					
	Initial Oil Change	Page 10		X				
	Periodic Oil Change	Page 11			X*			
Air Pre-Cleaner	Clean Sponge Element	Engine Manual & Page 11			X**			
Air Cleaner	Clean or Replace	Engine Manual			X**			
Spark Plug	Replace	Engine Manual					X	
Drive Belt	Check For Wear And Tension	Page 11 & 14			X	X		X
Mower Blade	Check For Wear, Damage & Replacement	Page 11-13	X					
Mower Deck	Clean Debris Accumulation	Page 11	X					
Transmission Grease	Check Grease Level	Pages 10			X			X

* Change oil every 25 hours when operating under heavy load or high temperatures.

**Clean more often under dusty conditions or when air debris is present.

MAINTENANCE/REPLACEMENT PARTS

MAINTENANCE PARTS	
Engine Speed Control	7-4138
Blade Control Cable	7-4141
Wheel Drive Control Cable	4-6518
21" Cutter Blade (Mulching)	2-6428
Engine to Transmission Belt	2-9492
Parts Manual for 21" Cast Aluminum Deck Commercial Walk Behind Series 2	06203

DECAL IDENTIFICATION

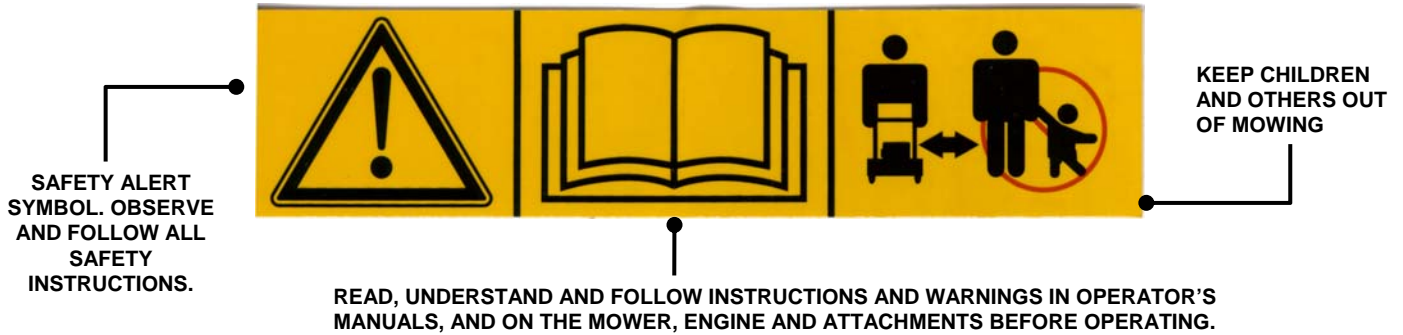

(1) WARNING INSTRUCTIONS.



(2) WARNING (DECK): Read and follow Starting and Safety Instructions in Owner's Manual. Improper use of machine can result in serious injury.

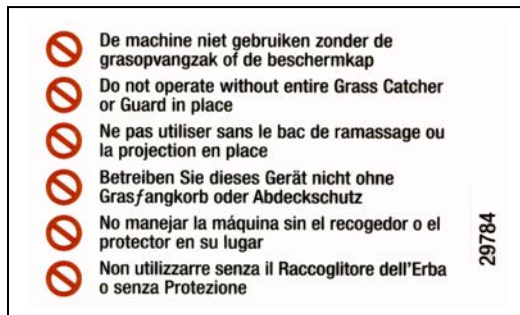

(3) WARNING: Do Not operate without entire Grass Catcher or Guard in place.



(4) WARNING: Located on the right side of the Mower Deck. It advises operator of the danger of the rotating blade.

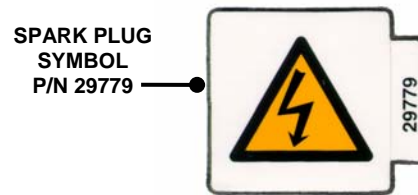

(5) SPARK PLUG: Warns of potential electrical shock from plug while engine is running.

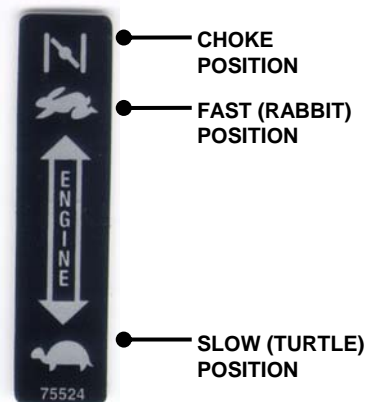

(6) ENGINE SPEED CONTROL: Indicates direction to increase Engine RPM (Rabbit), decrease Engine RPM (Turtle); also indicates position of choke.

DECAL IDENTIFICATION

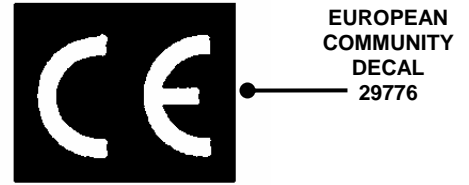
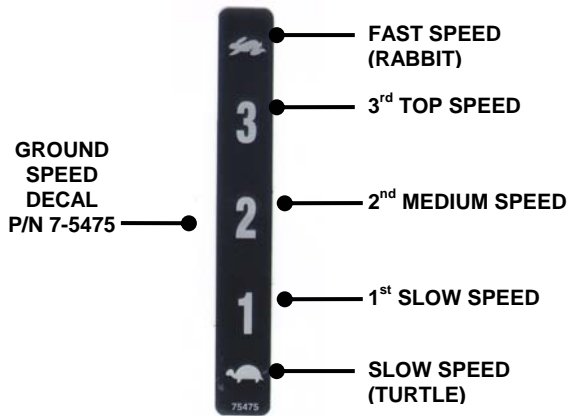

(10) **EUROPEAN PERFORMANCE:** Maximum level of vibration measured at the operators hand is 23.4 m/sec².

(7) **GROUND SPEED:** Shows direction of movement and the ability to select one of three ground speeds by moving the lever. The number 3 (Rabbit) indicates the top speed, number 2 indicates the medium speed and the number 1 (Turtle) indicates the slowest speed.

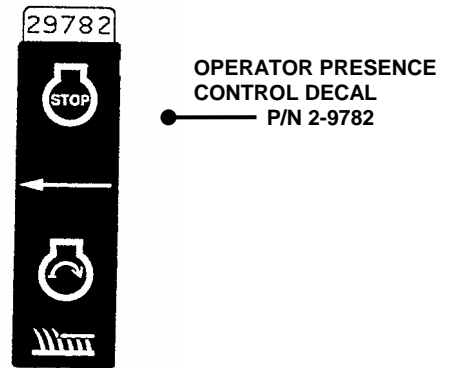
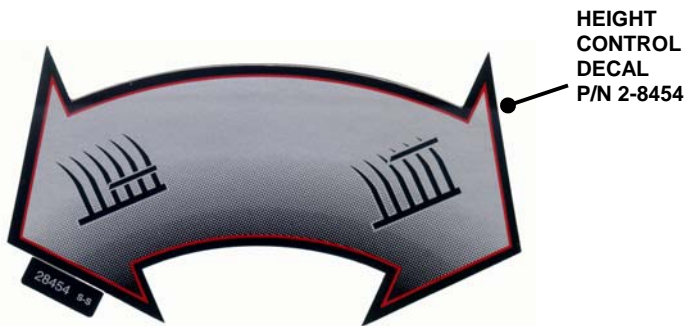

(8) **HEIGHT CONTROL INSTRUCTION:** Shows direction of movement of HEIGHT ADJUST HANDLE to select a change in height if cut from highest cutting height (clockwise) to the lowest height (counter-clockwise). Note that there is a total of eleven heights of cut.

(11) **OPERATOR PRESENCE CONTROL:** Pull control against handle to start engine and blade. Release control to stop engine and blade.

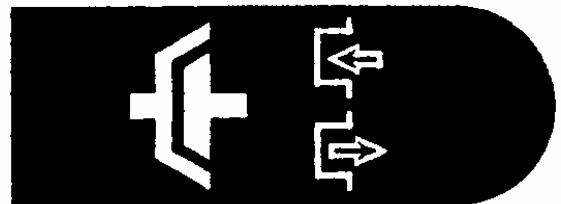
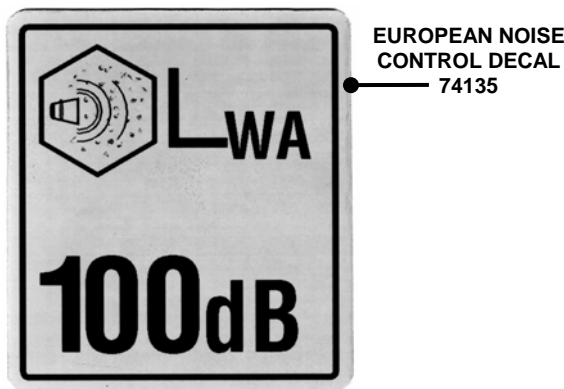

(12) **GROUND DRIVE:** Located on the plastic grip of the wheel drive control lever. Pull lever against handle to engage drive. Release lever to disengage drive.

(9) **NOISE CONTROL:** This unit is certified to be within the 100 dBA sound power limit at the specified Engine RPM.

DECAL IDENTIFICATION



CHUTE DEFLECTOR DECAL P/N 4-6924

(13) **WARNING:** DO NOT operate without grass catcher, side chute or plug installed.



WARNING
DECAL
P/N 1-3010

(14) **WARNING:** Located on the right side of the Mower Deck. It advises operator of the danger of the rotating blade.

SNAPPER®

2 YEAR LIMITED WARRANTY

For two (2) years from purchase date for the original purchaser's residential, non-commercial use, **SNAPPER**, through any authorized **SNAPPER** dealer will replace, free of charge (except for taxes where applicable), any part or parts found upon examination by the factory at McDonough, Georgia, to be defective in material or workmanship or both.

For one (1) year from purchase date for the original purchaser's commercial, non-residential use, **SNAPPER**, through any authorized **SNAPPER** dealer will replace, free of charge, any part or parts found upon examination by the factory at McDonough, Georgia, to be defective in material or workmanship or both.

For ninety (90) days from purchase date for the original purchaser's rental use, **SNAPPER**, through any authorized **SNAPPER** dealer will replace, free of charge, any part or parts found upon examination by the factory at McDonough, Georgia, to be defective in material or workmanship or both.

All transportation costs incurred by the purchaser in submitting material to an authorized **SNAPPER** dealer for replacement under this warranty must be paid by the purchaser.

This warranty does not apply to certain transmissions, to engines and their components, and batteries, as these items are warranted separately. This warranty does not apply to parts that have been damaged by accident, alteration, abuse, improper lubrication, normal wear, or other cause beyond the control of **SNAPPER**. This warranty does not cover any machine or component part that has been altered or modified changing safety, performance, or durability.

Batteries have a one (1) year warranty period with free replacement if required for one (1) year from the original purchase date. **SNAPPER** will not be responsible for any installation cost incurred. The battery warranty only covers original equipment batteries and does not cover damage to the battery or machine caused by neglect or abuse, destruction by fire, explosion, freezing, overcharging, improper maintenance, or use of improper electrolyte.

There is no other express warranty.

DISCLAIMER OF WARRANTY

Implied warranties, including those of merchantability and fitness for a particular purpose, are limited to two (2) years from purchase date for the original purchaser's residential or other non-commercial use, and one (1) year from purchase for the original purchaser's commercial, non-residential use, and ninety (90) days from purchase for the original purchaser's rental use, and to the extent permitted by law, any and all implied warranties are excluded. This is the exclusive remedy. Liabilities for consequential damages, under any and all warranties are excluded.

Some states do not allow limitations on how long an implied warranty lasts, or do not allow the exclusion or limitation of incidental or consequential damages, so the above limitation or exclusion may not apply to you.

This warranty gives you specific legal rights, and you may also have other rights which vary from state to state.

WARNING: THE USE OF REPLACEMENT PARTS OTHER THAN GENUINE SNAPPER PARTS MAY IMPAIR THE SAFETY OF SNAPPER PRODUCTS AND WILL VOID ANY LIABILITY AND WARRANTY BY SNAPPER ASSOCIATED WITH THE USE OF SUCH PARTS.

IMPORTANT: Please fill out the attached **SNAPPER** Product Registration Card immediately and mail to:
Snapper's Product Registration Center, P.O. Box 1379, McDonough, Georgia 30253

Safety Instructions & Operator's Manual for

SNAPPER®

EUROPEAN

21" CAST ALUMINUM DECK

WALK MOWERS

COMMERCIAL MODEL

SERIES 2

IMPORTANT

Snapper products are built using engines that meet or exceed all applicable emissions requirements on the date manufactured. The labels on those engines contain very important emissions information and critical safety warnings. Read, Understand, and Follow all warnings and instructions in this manual, the engine manual, and on the machine, engine and attachments. If you have any questions about your Snapper product, contact your local authorized Snapper dealer or contact Snapper Customer Service at Snapper, McDonough, GA. 30253. Phone: (1-800-935-2967).



WARNING

BATTERY POSTS, TERMINALS AND RELATED ACCESSORIES CONTAIN LEAD AND LEAD COMPOUNDS, CHEMICALS KNOWN TO THE STATE OF CALIFORNIA TO CAUSE CANCER AND BIRTH DEFECTS OR OTHER REPRODUCTIVE HARM. WASH HANDS AFTER HANDLING.



WARNING

ENGINE EXHAUST, SOME OF ITS CONSTITUENTS, AND CERTAIN VEHICLE COMPONENTS CONTAIN OR EMIT CHEMICALS KNOWN TO THE STATE OF CALIFORNIA TO CAUSE CANCER OR OTHER REPRODUCTIVE HARM.

SNAPPER® McDonough, GA., 30253 U.S.A.