

LTG

SERIES

12LTG36

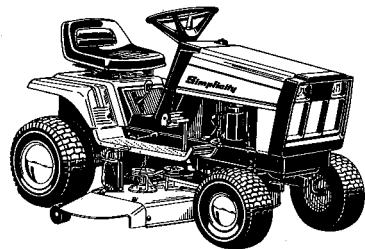

OPERATOR'S MANUAL

This manual covers the following Manufacturer's Numbers:

| | |
|---------------|---|
| 8 HP TRACTOR | MFG. NO. 1690840 MFG. NO. 1691027 |
| 10 HP TRACTOR | MFG. NO. 1691541 |
| 11 HP TRACTOR | MFG. NO. 1690843 MFG. NO. 1690909 MFG. NO. 1691028 |
| 12 HP TRACTOR | MFG. NO. 1691269 MFG. NO. 1691427 |
| 36" MOWER | MFG. NO. 1690838 MFG. NO. 1691419 |

GTI

21032

181138



Contents

| | | | |
|---|----|---|----|
| SAFETY RULES | 2 | TROUBLESHOOTING & REPAIR | 16 |
| DECALS | 4 | CONTENT OF SECTION | 16 |
| MOWER INSTALLATION & REMOVAL | 5 | TROUBLESHOOTING PROCEDURES | 16 |
| OPERATION | 7 | BATTERY REPLACEMENT | 18 |
| CONTROLS | 7 | JUMP STARTING | 18 |
| STARTING THE ENGINE | 8 | TRACTOR DRIVE BELT REPLACEMENT | 20 |
| SELECTING GEARS & ENGINE SPEED | 8 | MOWER BELT REPLACEMENT | 21 |
| STARTING & STOPPING | 8 | ADJUSTMENTS | 22 |
| BEFORE LEAVING OPERATOR'S POSITION | 9 | TRACTOR ADJUSTMENTS | 22 |
| MOWING PATTERN & TIPS | 9 | MOWER ADJUSTMENTS | 23 |
| NORMAL CARE | 10 | Mower Drive Belt Tension | 23 |
| DETERMINING OPERATION TIME | 10 | Arbor Belt Stops | 24 |
| NORMAL CARE SCHEDULE | 10 | Idler Pulley Belt Guide | 24 |
| RAISING HOOD & SEAT DECK/ ADJUSTING SEAT | 10 | PTO Pulley Belt Stops | 24 |
| CHECKING/ADDING GASOLINE | 11 | Levelling The Mower | 25 |
| LUBRICATING THE TRACTOR | 11 | Blade Brake | 26 |
| CHECKING THE FUEL FILTER | 11 | SMALL LIFT LEVER | 26 |
| CHECKING BATTERY FLUID | 12 | LARGE LIFT LEVER | 27 |
| CLEANING THE BATTERY & CABLES | 12 | SPECIFICATIONS | 28 |
| CHECKING TIRE PRESSURES | 12 | COMMON REPLACEMENT PARTS | 29 |
| TRACTOR NORMAL STORAGE | 12 | PARTS MANUAL AVAILABLE | 31 |
| TRACTOR OFF-SEASON STORAGE | 13 | | |
| STARTING AFTER STORAGE | 13 | | |
| LUBRICATING THE MOWER | 14 | | |
| SHARPENING & BALANCING THE BLADES | 14 | | |
| MOWER OFF-SEASON STORAGE | 15 | | |

NOTE

In this manual, "left" and "right" are referred to as seen from operating position.

Safety Rules



Read these safety rules and follow them closely. Failure to obey these rules could result in loss of control of vehicle, severe personal injury to yourself or bystanders, or damage to property or equipment. The triangle  in the text signifies important cautions or warnings which must be followed.

- Know the controls and how to stop quickly. **READ THIS OPERATOR'S MANUAL** and instructions furnished with attachments.
- Do not allow children to operate the machine. Do not allow adults to operate it without proper instruction.
- Do not carry passengers. Do not mow when children and others are around.
- Clear the work area of objects (wire, rocks, etc.) that might be picked up and thrown.
- Disengage all attachment clutches and shift into neutral before attempting to start the engine (motor).
- Disengage power to attachments and stop the engine (motor) before leaving the operator's position.
- Disengage power to attachments and stop the engine (motor) before making any repairs or adjustments.
- Disengage power to attachments when transporting or not in use.
- Take all possible precautions when leaving the vehicle unattended, such as disengaging the power-take-off, lowering the attachments, setting the parking brake, stopping the engine, and removing the key.
- Do not stop or start suddenly when going uphill or downhill. Mow up and down the face of steep slopes; never across the face.
- Reduce speed and exercise extreme caution on slopes and in sharp turns to prevent tipping or loss of control. Be especially cautious when changing direction on slopes.
- Stay alert for holes, rocks, and roots in the terrain and other hidden hazards. Keep away from drop-offs.
- Use care when pulling loads or using heavy equipment.
- a. Use only approved drawbar hitch points.
- b. Limit loads to those you can safely control.
- c. Do not turn sharply. Use care when backing.
- d. Use counterweights or wheel weights when suggested in this operator's manual.
- Watch out for traffic when crossing or near roadways.
- When using any attachments, never direct discharge of material toward bystanders or allow anyone near the vehicle while in operation.
- Handle gasoline with care — it is highly flammable.
 - a. Use approved gasoline container.
 - b. Never remove the fuel cap of, or add gasoline to, a running or hot engine or an engine that has not been allowed to cool for several minutes after running. Never fill the tank indoors and always clean up spilled gasoline.
 - c. Open doors if the engine is run in the garage — exhaust fumes are dangerous. Do not run the engine indoors.

- Keep the vehicle and attachments in good operating condition, and keep safety devices in place and in working condition.
- Keep all nuts, bolts, and screws tight to be sure the equipment is in safe working condition.
- Never store the equipment with gasoline in the tank inside a building where fumes may reach an open flame or spark. Allow the engine to cool before storing in any enclosure.
- To reduce fire hazard, keep the engine free of grass, leaves, or excessive grease.
- The vehicle and attachments should be stopped and inspected for damage after striking a foreign object, and the damage should be repaired before restarting and operating the equipment.
- Do not change the engine governor settings or overspeed the engine.
- When using the vehicle with mower, proceed as follows:
 - a. Mow only in daylight or in good artificial light.
 - b. Never make a cutting height adjustment while the engine (motor) is running if the operator must dismount to do so.
 - c. Shut the engine (motor) off when removing the grass catcher or unclogging chute.
 - d. Check the blade mounting bolts for proper tightness at frequent intervals.
- Under normal usage, the grass catcher bag material is subject to deterioration and wear. Check bag frequently for deterioration and wear and replace worn bags. Check that replacement bags comply with the original manufacturer's recommendations or specifications.
- Disengage power to mower before backing up. Do not mow in reverse unless absolutely necessary and then only after observation of the entire area behind the mower.

Decals

ALL WARNING, CAUTION, and instructional messages on your tractor and mower should be carefully read and obeyed. Personal bodily injury can result when these instructions are not followed. The information is for your safety and it is important. The safety messages on this page are on your tractor and mower.

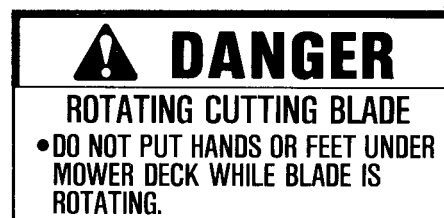
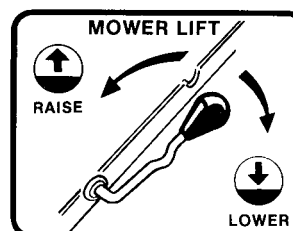
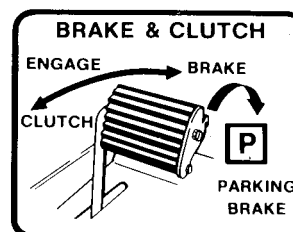
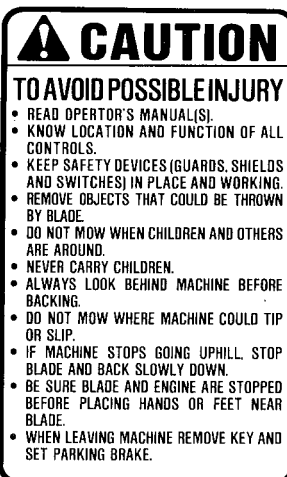
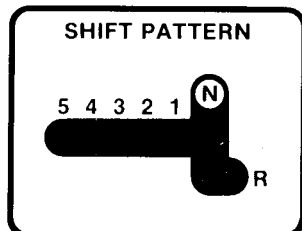
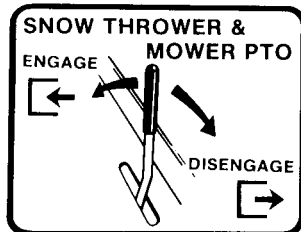

Mower Installation & Removal

WARNING

Engage the parking brake, disengage the PTO, stop the engine and remove the key before attempting to install or remove the mower.

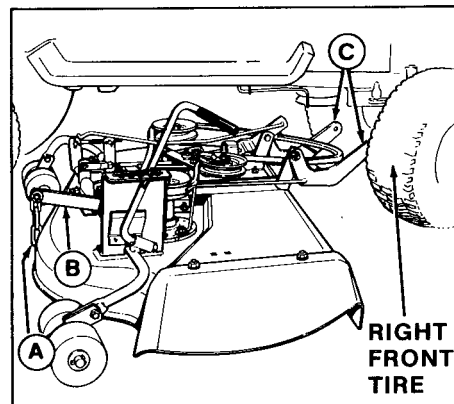

A. Lift Chain
B. Lift Arm
C. Hitch Arms

Figure 1. Installing 36" Mower

NOTE

The lift chain (A, figure 1) should be connected to the rear hole in lift arm (B) unless optional large lift lever (B, figure 8) is used to raise mower. With large lift lever, connect chain in forward hole.

1. Place your tractor and mower on a hard level surface, such as concrete, with the mower on the right side of the tractor.
2. Turn the front wheels of the tractor as far as they go to the left.
3. Place the mower in the lowest cutting

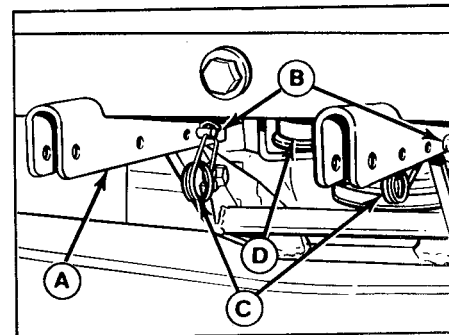

A. Hitch
B. Pins
C. Safety Clips
D. Drive Belt

Figure 2. Mower Hitch Attached

position and slide it under the tractor (see figure 1). Align arms (C, figure 1) in tractor hitch (A, figure 2).

4. Insert the link (A, figure 3) into lift arm (B) then pivot back and down. Secure chain (C) to clevis (D) with pin (E) and clip (F). (Early models are equipped with a simple hook instead of clevis assembly shown in figure 3.) Use on three links of chain.
5. Lift up front of mower and insert pins (B, figure 2) to attach mower hitch arms to tractor hitch (A). (You can insert a pry bar under front edge of deck to raise.) Connect the clips (C) into the pins.

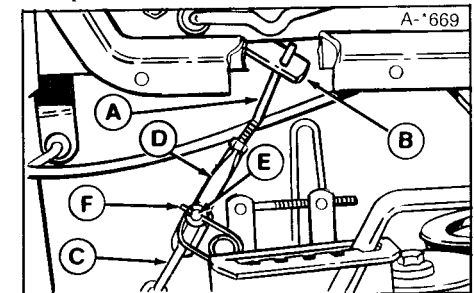

A. Lift Link
B. Lift Arm
C. Chain
D. Clevis
E. Pin
F. Clip

Figure 3. Lift Assembly

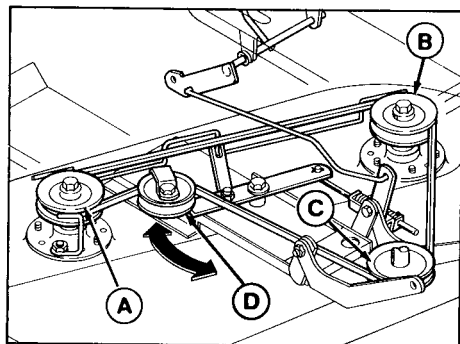

- A. V-Pulley, Right Arbor
- B. V-Pulley, Left Arbor
- C. Engine PTO Pulley
- D. Flat Idler Pulley

Figure 4. Mower Belt Pattern - 36"

6. Slip the mower drive belt onto the PTO pulley. Loosen belt stops as necessary. The left-hand belt stop is item A in figure 5. The right-hand belt stop is item A in figure 6.
7. Make sure the belt is properly installed on the mower pulleys. The belt pattern is shown in figure 4.
8. Insert one end of the PTO rod (B, figure 7) in the mower PTO arm (A) and the

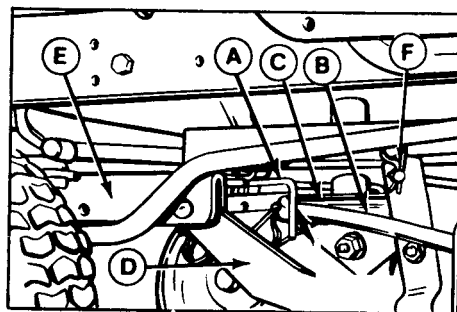

- A. Belt Stop
- B. Belt
- C. PTO Pulley
- D. Mower Hitch Arm
- E. Tractor Hitch
- F. Spring Clip

Figure 5. Left-Hand Belt Stop

other end in the tractor PTO arm (C) in hole marked "MOW". The rod must be inserted into the holes from the right-hand side as shown. Refer to figure 7 to make sure you connected correct end of rod to front. Install the spring clips (D).

9. If installing mower for the first time, or if a new belt was installed, perform the mower adjustments in the Adjustments section.

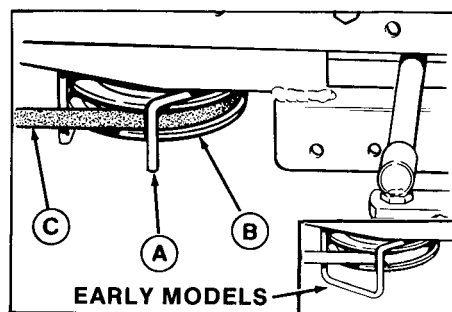

- A. Belt Stop
- B. PTO Pulley
- C. Belt

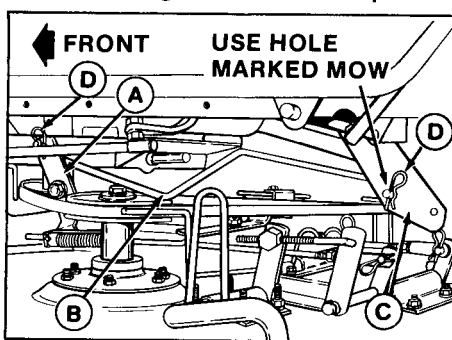

- A. Mower PTO Arm
- B. PTO Rod
- C. Tractor PTO Arm
- D. Spring Clip

Figure 7. Installing PTO Rod

10. Reverse the procedure to remove the mower.

Operation

CONTROLS

Refer to figure 8 for an explanation of tractor and mower controls.

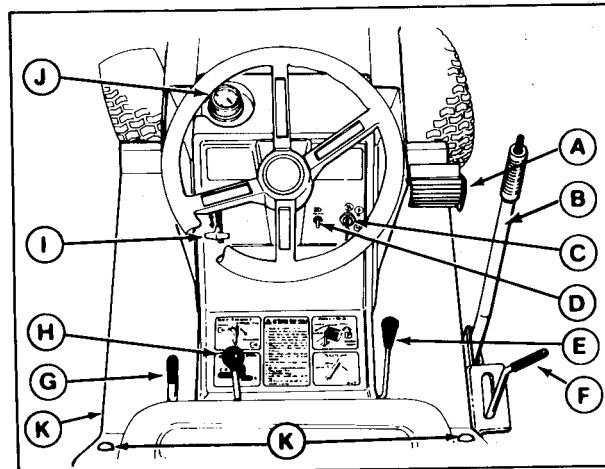

Figure 8. Tractor & Mower Controls

INTERLOCK SWITCHES

Mfg. No. 1691027 and higher are equipped with a seat switch which will stop the engine if operator leaves seat when PTO is engaged and/or transmission is in gear. Also, switch will prevent starting if operator is not in seat. The other models are not equipped with this switch. On all models, the PTO must be disengaged and transmission in NEUTRAL to start engine.

| ITEM | NAME | FUNCTION |
|------|----------------------------|--|
| A | Clutch-Brake | Disengages tractor clutch when pressed down at least halfway. Applies brake when fully depressed. Engages parking brake when latched over footrest. |
| B | Optional Lift Lever | Lifts and holds attachments in transport position (only required with attachment other than mower). (Optional) |
| C | Ignition Switch | Operates with key to start, run, or stop engine. |
| D | Light Switch | Switches headlights on or off (if equipped). |
| E | Lift Lever | Lifts and holds mower in transport position. |
| F | Mower Height Control Lever | Adjusts mower cutting height. |
| G | PTO (Power Take Off) Lever | Engages and disengages power to attachment. Pull back to disengage. |
| H | Gear Shift Lever | Shifts transmission gears to control ground speed. Five speeds forward, one speed reverse. |
| I | Engine Speed Control | Position from SLOW to FAST to control engine speed. Also position for engine CHOKE. |
| J | Gas Gauge/ Cap | Shows amount of gasoline in the tank and serves as tank cap. |
| K | Seat Deck Release | Push Button Model: Press button on each side to tilt seat deck back. Seat Latch Model: Pull down on latch underneath left footrest while raising seat deck. |

STARTING THE ENGINE

1. Seat yourself on tractor seat, in operating position. Set the parking brake.
2. Set engine speed control to CHOKE. A warm engine may not require choking.
3. Lift PTO lever as far as it will go to the rear to disengage the attachment.
4. Set gear shift lever in NEUTRAL.
5. Insert the key into the ignition switch and turn it to START. When engine starts, release the key.
6. Move the engine speed control to SLOW. Warm up the engine by running it for at least a minute before engaging the PTO lever or driving the tractor.

SELECTING GEARS & ENGINE SPEED

Most mowing is done in third or fourth gear with engine speed between 3/4 and full speed. If the terrain is rough, hilly, or sloping use first or second gear. If the grass is wet or over three inches (76 mm) high, use full engine speed (with low gear) so the mower will have enough power to cut the grass. Shift gears only with tractor stopped and clutch-brake pedal fully depressed.



WARNING

Slope Operation

Never operate on slopes greater than 30 percent (16.7°) which is a rise of three feet vertically in 10 feet horizontally. When operating on slopes that are greater than 15 percent (8.5°) but less than 30 percent use rear wheel weights (see your dealer). Select slow ground speed before driving onto slope. Mow UP and DOWN the slope, never across the face, use caution when changing directions and DO NOT START OR STOP.

STARTING & STOPPING

1. Refer to Normal Care Chart and perform any needed care.
2. Clear the work area of any objects which may be caught in or thrown by mower.
3. Position the front wheels straight ahead. If possible, the first motion should be straight forward or backward.
4. Start the engine.
5. Set engine control for 1/3 to 1/2 speed. Select the gear best suited for conditions.
6. Release the parking brake by unlatching clutch-brake pedal from the foot rest.
7. Make sure the path in desired direction of movement is clear.
8. If you are ready to mow, engage the mower PTO with moderately fast motion. Engaging PTO too slowly may cause belt wear.
9. Slowly release the clutch-brake pedal to engage clutch and start tractor into motion.
10. Adjust engine speed control to desired speed. Between 3/4 and full speed is recommended for mowing.
11. For a gradual stop, press the pedal down only far enough to disengage the clutch. For a more rapid stop, press pedal down farther to apply the brake. See "Before Leaving Operator's Position" (next page).

BEFORE LEAVING OPERATOR'S POSITION

1. Stop tractor motion, and engage the parking brake.
2. Disengage the PTO and lower the attachment.
3. Set engine speed control to SLOW. Stopping a hot engine too fast may cause engine damage. Let engine idle for about a minute.
4. Turn key to OFF and remove it.



WARNING

Before leaving the operator's position for any reason, engage the parking brake, disengage the PTO, stop the engine and remove the key.



WARNING

To reduce fire hazard, keep the engine, tractor and mower free of grass, leaves and excess grease.

MOWING PATTERN & TIPS

For the first use of the mower choose a smooth level area. Cut long straight strips overlapping slightly.

The size and type of area to be mowed determine the best mowing pattern to use. Obstructions such as trees, fences and buildings must also be considered. Where possible, make one or two passes in a clockwise direction around the outside of the area to keep cut grass off fences and walks. The remainder of the mowing should be done in a counterclockwise direction so the clippings are dispersed on the cut area.

Where possible, keep the left side of the mower toward trees, posts, or other obstacles on the first pass around the obstacles to keep hand trimming to a minimum.

On moderate size, frequently mowed lawns where grass is light and dry, it is sometimes practical to mow in a clockwise direction so that clippings are thrown toward the center of the lawn and concentrated for pickup and removal.

Most lawns should be mowed to keep the grass approximately two to three inches (50 to 76 mm) high. Best results are obtained by cutting often and not too short. To help keep a green lawn, never mow more than one third off the height of the grass, or a maximum of one inch (25 mm), in one mowing. For extremely tall grass, set the cutting height at maximum for the first pass, and then reset to the desired height and mow again.

On thick, or springy grass or soft ground, the mower rollers may sink into the ground giving too low a cut. Adjust the cutting height as necessary. For best appearance, grass should be cut in the afternoon or early evening (in daylight) when it is free of external moisture.

Where possible, change patterns occasionally to eliminate matting, graining or a corrugated appearance.

Normal Care

DETERMINING OPERATING TIME

Determining operating time is easily accomplished if the tractor is equipped with an optional hourmeter. If not, multiply the time it takes to do one job by the number of times you've done the job.

NORMAL CARE SCHEDULE

A schedule for normal care is provided in Table I.

RAISING HOOD & SEAT DECK

To raise the hood, grasp both sides of the hood near the dash and pull outward. There are two styles of seat latches. If there is a button on each side of seat deck near the foot rests, press in both buttons and tilt the seat deck back. On other models, pull down the latch under the foot rest and tilt seat deck back.

ADJUSTING THE SEAT

Raise the seat deck. While holding the seat, loosen the four capscrews that secure seat to seat deck. Position the seat as desired then tighten the capscrews.

| Care Required | See | Schedule | | | | | |
|--|---------------|------------------|-----------------|---------------|-------------------|-----------------|---------------------|
| | | Before First Use | Before Each Use | Every 5-Hours | ** Every 25 Hours | Every 100 Hours | *** Spring and Fall |
| Check gas gauge | P. 11 | • | • | | | | |
| Check tractor & mower for loose nuts, screws, bolts, oil leaks, etc. | | • | • | • | | | |
| Check engine oil level | Engine Manual | • | • | • | | | |
| Clean engine & air filter | Engine Manual | | | | • | | |
| Change engine oil* | Engine Manual | | | | • | | • |
| Lubricate tractor & mower | P. 11,14 | • | | | • | | |
| Check battery fluid | P.12 | • | | | • | | |
| Clean battery & cables | P.12 | | | | | • | |
| Clean/sharpen blades | P.14 | | | | | • | |
| Inspect spark plug(s) | Engine Manual | | | | | • | |
| Check fuel filter | P.11 | | | | | • | |
| Check tire pressures | P.12 | • | | | • | | |

*Change original engine oil after first 5 hours of operation.
 **More often in hot (over 85°F; 30°C) weather or dusty operating conditions.
 ***Only if tractor is used in both summer (over 40°F) and winter (under 40°F; 4.5°C)

Table 1. Schedule of Normal Care - Tractor & Mower.

CHECKING/ADDING GASOLINE

Check the gas gauge/cap to be sure there is enough gasoline to complete the job. To add gasoline, remove the gas gauge/cap. Refer to your engine manual for gasoline recommendations. Install and hand tighten the gas gauge/cap.

LUBRICATING THE TRACTOR

Lubricate the tractor as shown in figures 9 thru 12. When a grease gun is shown, wipe the fitting clean, apply two or three shots of lithium base automotive grease, and wipe off excess grease. When an oil can is shown wipe the area clean, apply a few drops of oil (SAE 30), then wipe up drips or spills.

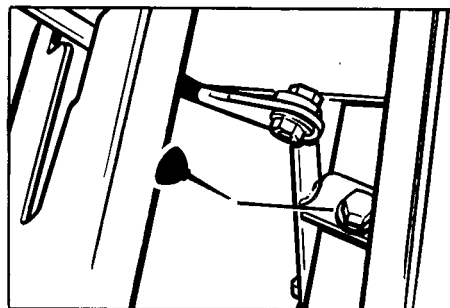

Figure 9. Shift Lever Lubrication

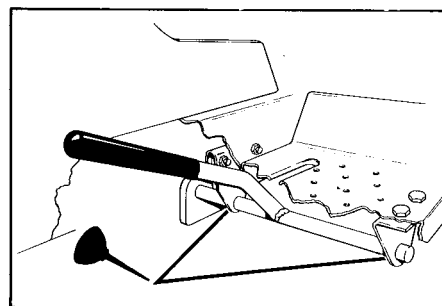

Figure 10. PTO Lever Lubrication

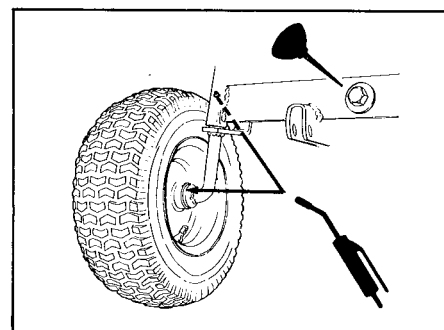

Figure 11. Front Axle Lubrication
(Two grease fittings on each side)

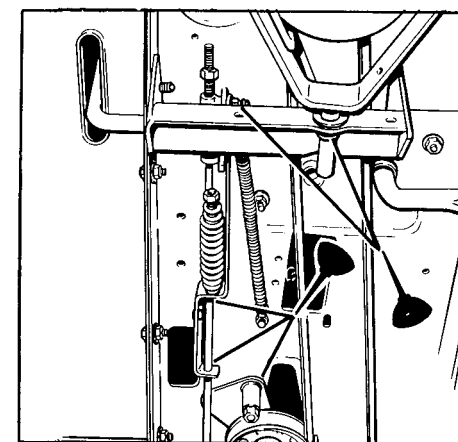

Figure 12. Clutch & Brake Rod Lubrication

CHECKING THE FUEL FILTER



WARNING

Do not remove fuel filter when engine is hot, as spilled gasoline may ignite. Do not spread hose clamps further than necessary. Insure clamps grip hoses firmly over filter after installation.

The fuel filter is located in fuel line between fuel tank and carburetor. If filter is dirty or clogged, replace as follows. Place a container below filter to catch spilled gasoline.

1. Using a pliers, open and slide hose clamps from fuel filter.
2. Remove hoses from filter.
3. Install new filter in proper flow direction in fuel line. Secure by reclamping with hose clamps. See warning at beginning of procedure.

CHECKING BATTERY FLUID

1. Raise the seat.
2. Remove filler caps, one at a time.
3. Fluid must be even with split ring full mark (figure 13). If not, add distilled water.
4. Reinstall filler caps.

CLEANING THE BATTERY & CABLES



WARNING

Be careful when handling the battery. Avoid spilling electrolyte. Keep flames and sparks away from the battery.



WARNING

When removing or installing battery cables, disconnect the negative cable **FIRST** and reconnect it **LAST**. If not done in this order, the positive terminal can be shorted to the frame by a tool.

1. Disconnect the cables from the battery, negative cable first (figure 13).

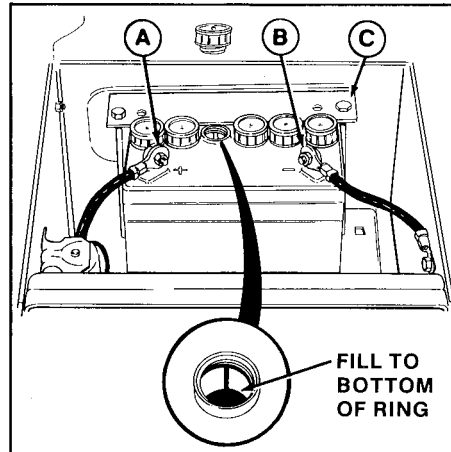

A. Positive Terminal C. Battery Clamp
B. Negative Terminal
Figure 13. Battery

2. Remove the battery clamp, then remove the battery.
3. Scrub the battery, cables, and battery compartment with baking soda and water.
4. Clean the battery terminals and cable clamps with a wire brush.
5. Reinstall battery and clamp (figure 13).
6. Connect cables, positive cable first.
7. Coat cable clamps and terminals with grease or petroleum jelly.

CHECKING TIRE PRESSURE

Check air pressure of all four tires. Front tires should be 12 to 15 psi. Rear tires should be 6 to 8 psi. A gauge with one-pound markings will be necessary for an accurate check.

TRACTOR NORMAL STORAGE

Clean all grass and dirt from the mower. To protect your tractor, store it in an enclosed dry area. Do not store it in an enclosure where fumes from the fuel tank could reach an open flame. Clean the seat with a vinyl cleaner.

To store your tractor in a cold area between winter snow removal jobs, we suggest that you fill the fuel tank at the completion of each job to prevent water condensation in the fuel tank. Wait for engine to cool before filling tank.

TRACTOR OFF-SEASON STORAGE

When the tractor is to be stored for two months or longer, take precautions as follows:



WARNING

Gasoline is highly flammable. Keep open flame or spark away from gasoline and fuel tank. Never store tractor where gasoline fumes may reach an open flame or spark.

1. To empty or prepare fuel tank:
 - a. Run tractor engine until it stops from lack of fuel, or;

- b. Use a gasoline stabilizer. This additive, available from your dealer, prevents formation of gum and varnish for up to one year. With the additive, fuel may remain in your tank for long periods.
2. Change engine oil while the engine is still warm. Record the type and weight of oil put in crankcase.
3. Remove spark plug(s). Pour one ounce (30 ml) of SAE 30 oil into engine through spark plug hole(s). Crank engine a few times to distribute oil and then reinstall the spark plug(s).
4. Lubricate the tractor. (See page 11).
5. Check battery fluid level (page 12). Battery life will be extended if it is removed and stored in a cool, dry place, fully charged.
6. Clean tractor thoroughly. Coat all exposed bare metal parts with a good quality paint (obtainable from your dealer) or a light film of grease or oil.

STARTING AFTER STORAGE

1. Replace battery, if removed. Be sure terminals and clamps are clean (see page 12).
2. Remove the spark plug and wipe dry. Crank engine a few times to blow excess oil out of plug hole. Reinstall the plug.
3. Fill fuel tank with fresh gasoline (unless a fuel stabilizer was used).
4. Clean engine fins and air filter. (See engine manual.)
5. Check fluid levels and tire pressure. (See Normal Care Chart.)
6. Start the engine outdoors. Do not run engine at high speeds immediately after starting.

LUBRICATING THE MOWER

Lubricate the mower as shown in figure 14 thru 16. Also lubricate the grease fittings on the mower idler pulley and arbors (underneath deck). Use an oil can with medium weight (SAE 30) oil. Brush and wipe dirt and grass from the area before applying oil. Wipe up drips and spills. Keep oil off belts and pulleys.

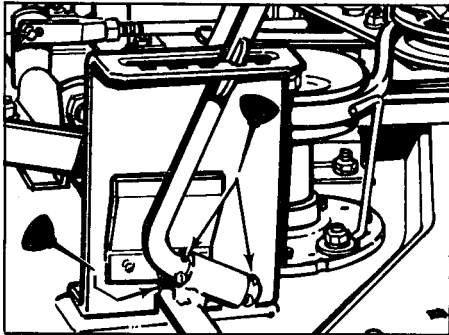

Figure 14. Lubricate Height Control Lever & Point Where Roller Bar Contacts Bracket.

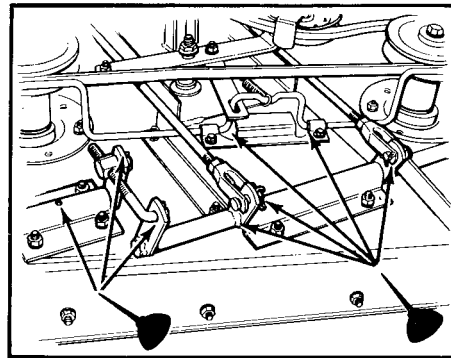

Figure 15. Lubricate Brake Lever, Clevises, & Levelling Rod.

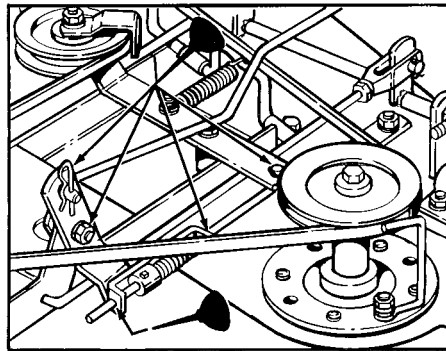

Figure 16. Lubricate Hitch, PTO Rod and PTO Arm

SHARPENING & BALANCING THE BLADES

1. Remove the mower from the tractor.
2. Position the mower as in figure 17. Secure the mower so it will not fall or slide.



WARNING

Do not handle the mower blades with bare hands. Avoid touching the cutting edge. Careless or improper handling of blades may result in serious injury.

3. Remove any dirt or foreign matter from inside the mower deck and blade.
4. To remove the blade for sharpening use a wooden block to hold blade while removing the capscrew (figure 17).
5. Use a file to sharpen blade to fine edge. Remove all nicks and dents in blade edge. If blade is severely damaged, it should be replaced.

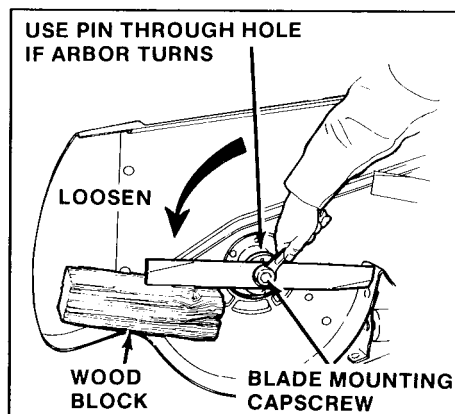

Figure 17. Removing Blade

6. Check and balance blade. Use a balancing machine or the fixture shown in figure 18. Center the blade on a nail lubricated with a drop of oil. A balanced blade will remain level. File material off heavier end of blade until it is balanced.
7. Reinstall each blade with the tabs pointing up toward deck and secure with a cap screw, cup washer, and spline washer. Be sure all splines are aligned and washer is flush against blade. Use a wooden block to prevent blade rotation

and torque cap screw to 55 ft. lbs. (74 N.m) (figure 19).

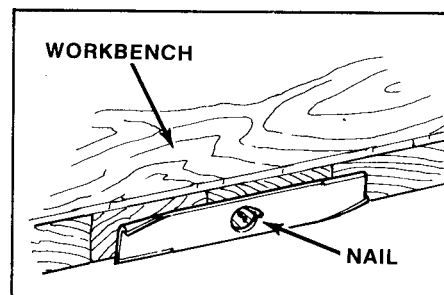

Figure 18. Balancing Blade

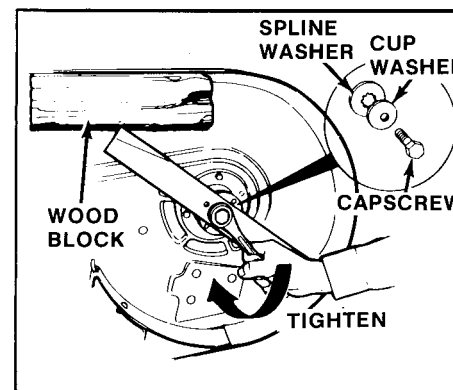

Figure 19. Installing Blade



WARNING

Blade mounting cap screws must be installed with the cup washer and spline washer and then securely tightened. Torque blade mounting cap screws to 55 ft. lbs. (74 N.m).

MOWER OFF-SEASON STORAGE

To protect your mower, store it in an enclosed dry area. To prepare the mower for off-season storage perform the following.

1. Remove mower from tractor if tractor is to be used without mower. (See Mower Installation and Removal section).
2. Clean top and underside of mower to remove all grass and dirt.
3. Coat all bare metal surfaces with a good quality paint (available from your dealer) or a light coat of oil to prevent rusting.
4. Lubricate mower (page 14).
5. Check, sharpen and balance the mower blades (page 14).
6. The belt should be stored in a cool, dark place away from sunlight or any heat source.

Troubleshooting & Repair

CONTENT OF SECTION

This section of the manual provides troubleshooting and repair instructions for the more common and easily corrected problems. For other problems, it is recommended that you contact your dealer.



WARNING

To avoid serious injury, perform maintenance on the tractor or mower only when the engine is stopped and the parking brake engaged. Always remove the ignition key and disconnect spark plug wire and fasten away from the plug before beginning the maintenance to prevent accidental starting of the engine.

TROUBLESHOOTING PROCEDURES

Troubleshooting procedures are provided in Table 2. To use these procedures, first locate the problem description that best describes the trouble that you have encountered. Check the possible causes one at a time in the order that they are listed.

1. **Engine will not start.**
 - A. Gear shift lever not in neutral start position. Shift into neutral.
 - B. PTO clutch lever not disengaged. Disengage fully.
 - C. Operator not seated. Operator must be in seat on models equipped with seat switch.
 - D. Out of fuel. Refill fuel tank.
 - E. Engine flooded. Move control out of choke, & attempt to start.
 - F. Circuit breaker tripped. Wait one minute for automatic reset. Replace if defective (see your dealer).
 - G. Battery terminals require cleaning. See Normal Care section.
 - H. Battery discharged or dead. Recharge or replace.
 - I. Wiring loose or broken. Visually check wiring & replace broken or frayed wires.
 - J. Solenoid or starter motor faulty. Repair or replace.
 - K. Safety interlock switch faulty. Replace if needed. (See your dealer.)
 - L. Spark plug or points, fouled, or incorrectly gapped. Clean & gap or replace.
 - M. Water in fuel tank. Drain fuel & refill with fresh fuel.
 - N. Old stale gas. Drain fuel & replace with fresh fuel.
2. **Engine starts hard or runs poorly.**
 - A. Fuel mixture too rich. Move control out of choke. If problem still exists, clean air filter.
 - B. Carburetor adjusted incorrectly. See your engine manual.
 - C. Spark plug or points faulty, fouled or incorrectly gapped. Clean and gap or replace.

Table 2. Troubleshooting

Troubleshooting & Repair

3. Engine knocks.

- A. Low oil level. Check/add oil as required.
- B. Using wrong grade oil. See Normal Care section.

4. Excessive oil consumption.

- A. Engine running too hot. Clean engine fins, blower screen and air cleaner. See Normal Care section.
- B. Using wrong weight of oil. See Normal Care section.
- C. Too much oil in crankcase. Drain excessive oil.

5. Engine exhaust is black or smoky.

- A. Dirty air filter. Clean air filter.
- B. Choke not fully open. Move control out of choke and be sure choke opens fully. If problem still exists, check carburetor adjustment.

6. Engine runs, but tractor will not drive or lacks power.

- A. Transmission not in gear. Shift into gear.
- B. Drive belt slips. (See problem and cause below.)

7. Drive belt slips.

- A. Clutch or belt tension is out of adjustment. See Adjustment section.
- B. Pulleys or belt greasy or oily. Clean as required.
- C. Belt stretched or worn. Replace with correct belt.
- D. Clutch rod binding in guide. Oil clutch rod. See Tractor Lubrication.

8. Brake will not hold.

- A. Brake is incorrectly adjusted. See Adjustment section.
- B. Brake pads worn & require replacement. See your dealer.

9. Tractor handles poorly.

- A. Steering linkage is loose. Check and tighten any loose connections.
- B. Improper tire inflation. Check and correct.
- C. Wheels are spinning and slipping. Use weights to provide additional stability and traction.
- D. Moving too fast on slopes. Reduce speed.

10. Main tractor drive belt does not stop when clutch-brake pedal is depressed.

- A. Belt stops out of adjustment. See Adjustments section.
- B. Belt tension out of adjustment. See Adjustments section.

TROUBLESHOOTING (MOWER)

1. Mower will not raise.

Lift chain not attached or broken. Attach or repair.

2. Uneven cut.

- A. Mower not leveled properly. See leveling adjustment in Mower Adjustment section.
- B. Tractor tires not inflated equally or properly.

3. Mower cut is rough looking.

- A. Engine speed too slow. Set for three-fourths to full speed.
- B. Tractor ground speed too fast. Use lower gear.

Table 2. Troubleshooting (Cont'd)

3. Mower cut is rough looking. (Cont'd.)

- C. Blades dull & require sharpening. See Normal Care section.
- D. Mower drive belt slipping. Belt oily or worn. Clean or replace belt as necessary. Readjust belt tension.

4. Engine stalls easily with mower engaged.

- A. Tractor ground speed too fast. Use lower gear.
- B. Engine Speed too slow. Set for three-fourths to full speed.
- C. Cutting height set too low when mowing tall grass. Cut tall grass at maximum cutting height during first pass.
- D. Discharge chute jamming with cut grass. Cut grass with discharge pointing toward previously cut area.

5. Excessive mower vibration.

- A. Blade mounting screws are loose. Torque to 55 ft.lbs. (74 N.m). See Normal Care section.
- B. Mower blades, arbors, or pulleys are bent. Check and replace as necessary.
- C. Mower blades are out of balance. Remove, sharpen, and balance blades (see Normal Care section).

6. Excessive belt breakage.

- A. Belt tension too tight. Readjust belt tension.
- B. Bent or rough pulleys. Repair or replace.
- C. Using incorrect belt. See your dealer.

7. Mower drive belt slips or fails to drive.

- A. Mower drive belt out of adjustment. See Adjustment section.
- B. Mower drive belt broken. Replace belt.

Table 2. Troubleshooting (Cont'd.)

BATTERY REPLACEMENT

A dead battery or one too weak to start the engine may not mean the battery needs to be replaced. It may, as an example, mean that the charging system is not working properly or that the battery has lost its charge during storage. First, "Clean Battery & Cables" and "Check Battery Fluid Level" as described on page 12. Have the battery recharged if necessary. If there is any doubt about the cause of the problem, see your dealer. If you must replace the battery, remove and install the battery as described in "Clean Battery & Cables".

JUMP STARTING WITH AUXILIARY (BOOSTER) BATTERY

Jump starting is not recommended. First, check the battery as described in "Battery Replacement" above. If jump starting must be done, follow these instructions. Both booster and discharged batteries should be treated carefully when using jumper cables. Follow exactly procedures one through five, being careful not to cause sparks.



WARNING

For your personal safety use extreme care when jump starting. Never expose battery to open flame or electric spark — battery action generates hydrogen gas which is flammable and explosive. Do not allow battery acid to contact skin, eyes, fabrics, or painted surfaces. Batteries contain a sulfuric acid solution which can cause serious personal injury or property damage.

1. Set parking brake and place transmission in "NEUTRAL". Turn off lights and other electrical loads.
2. Remove vent caps from both the booster and the discharged batteries. Lay a cloth over the open vent wells on each battery. These two actions help reduce the explosion hazard always present in either battery when connecting a "live" battery to a "dead" battery.

3. Attach one end of one jumper cable to the positive terminal of the booster battery (identified by a red color, "+" or "P" on the battery case, post or clamp) and the other end of same cable to positive terminal of discharged battery. DO NOT permit vehicles to touch each other, as this could establish a ground connection.
4. Attach one end of the remaining cable to the negative terminal (black color, "-" or "N") of the booster battery, and the other end to a bare metal surface on the frame of your tractor AWAY FROM the battery compartment (do not connect directly to negative post of dead battery). Take care that clamps from one cable do not inadvertently touch the clamps on the other cable. Do not lean over the battery when making this connection.
5. The tractor with the discharged battery should now start.

Reverse the jump starting procedure exactly to remove the jumper cables. Then reinstall the vent caps and throw the cloths away as they may have corrosive acid on them.



WARNING

Any procedure other than the above could result in: (1) personal injury caused by electrolyte squirting out of the battery vents, (2) personal injury or property damage due to battery explosion, (3) damage to the charging system of the booster vehicle or the immobilized vehicle.

Do not attempt to jump start a vehicle having a frozen battery because the battery may rupture or explode. If a frozen battery is suspected, examine all fill vents of the battery. If ice can be seen or if the electrolyte fluid cannot be seen, do not attempt to start with jumper cables as long as the battery remains frozen.

TRACTOR DRIVE BELT REPLACEMENT



CAUTION

To avoid damaging belt do not pry belt over pulleys.

1. Set the parking brake.
2. Remove mower from tractor.
3. Remove the nut, washers, and capscrew (A, figure 20) from the gear shift lever (B). Remember position of hardware for reinstallation.

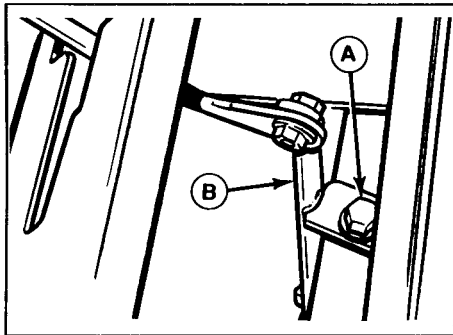

A. Hardware B. Gear Shift Lever
Figure 20. Gear Shift Lever

4. Remove the belt guide from the idler pulley (figure 21).

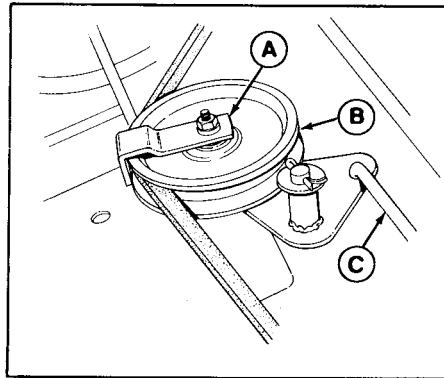

A. Belt Guide
 B. Idler Pulley
 C. Clutch Rod

Figure 21. Removing Belt Guide

5. Remove the belt from the engine drive pulley and idler pulley.
6. Turn the belt sideways to slip it off the transmission pulley and remove belt from tractor by slipping it over the gear shift lever.

7. Install the new belt in reverse order of removal procedure. The belt pattern is shown in figure 22.

8. Install the nut, washers, and capscrew at gear shift lever (figure 20). Reinstall the belt guide (figure 21). The belt guide should be positioned perpendicular to tractor. The belt should not touch the guide when tractor is engaged.

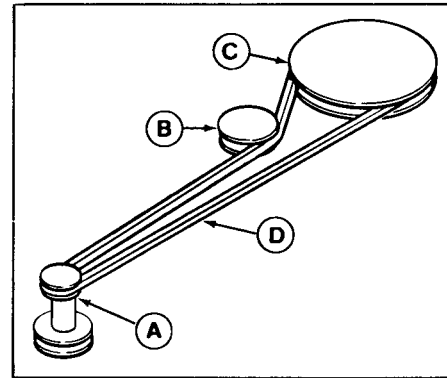

A. Engine Pulley C. Transmission Pulley
 B. Idler Pulley D. Drive Belt

Figure 22. Tractor Belt Pattern

MOWER BELT REPLACEMENT



CAUTION

To avoid damaging belt do not pry belt off pulleys.

1. Remove mower from the tractor.
2. Loosen the belt guide (C, figure 23) on the idler pulley.
3. Remove the belt from the pulleys.
4. Install the new belt on the pulleys as shown in figure 24.
5. Reposition the belt guide on the idler pulley (figure 23). Before tightening the nut (D), position the belt guide so it is 1/4 inch (6 mm) behind the idler arm (B) when viewed from above (figure 23). Hold the belt guide when tightening nut.
6. Reinstall the mower on the tractor (see Mower Installation). Check mower drive belt tension as outlined in the Adjustment section. Run the mower under no load conditions for about 5 minutes and recheck the mower drive belt tension.

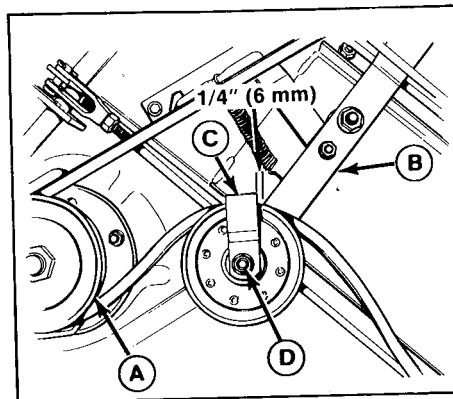

- A. Arbor Pulley
- B. Idler Arm
- C. Belt Guide
- D. Nut

Figure 23. Mower Belt Replacement

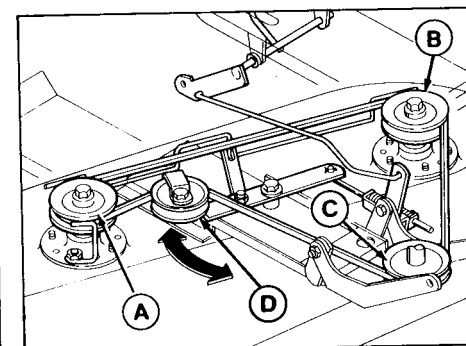

- A. V-Pulley, Right Arbor
- B. V-Pulley, Left Arbor
- C. Engine PTO Pulley
- D. Flat Idler Pulley

Figure 24. Mower Belt Pattern - 36"

NOTE

Each time after changing the mower belt tension, perform the remaining mower adjustments: Right-Arbor Belt Stop, Idler Pulley Belt Guide and PTO Pulley Belt Stops.

Adjustments



WARNING
To avoid serious injury, perform adjustment only with engine stopped, key removed, and tractor on level ground.

TRACTOR ADJUSTMENTS

1. Adjust parking brake as follows:
 - a. Place the transmission in gear and release the parking brake. Move the brake rod (I, figure 26) back and forth to be sure there is no tension on the brake pads.
 - b. Push the cam lever (A, figure 25) forward (toward front of tractor) to take out any slack. The gap between lever (A) and stop (B) should be 1/8 inch (0.3 mm). Use a feeler gauge to measure. If not 1/8 inch, perform step "c".

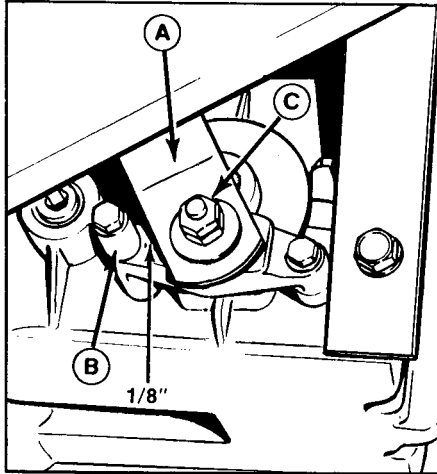

A. Brake Cam Lever C. Adjustment Nut
B. Stop

Figure 25. Parking Brake Adjustment

- c. Loosen or tighten the adjustment nut (C) to achieve correct dimension. Some models are equipped with two nuts. If so, loosen the outer nut, adjust the inner nut as necessary, then tighten the outer nut.

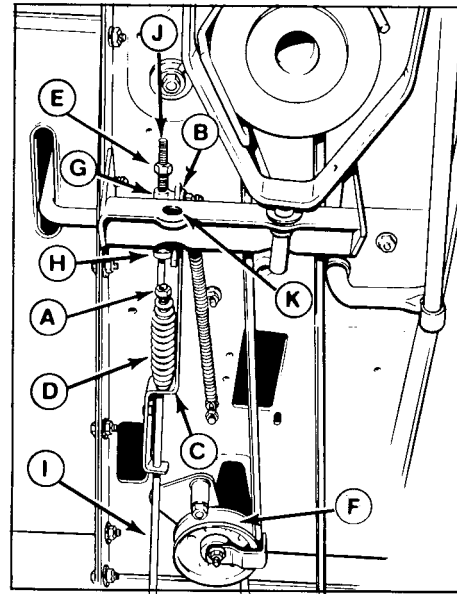

| | |
|------------------------------|---------------------|
| A. Nut | G. Clutch Rod Guide |
| B. Slot (in brake rod guide) | H. Set Collar |
| C. Brake Rod Guide | I. Brake Rod |
| D. Spring | J. Clutch Rod |
| E. Nut | K. Hole, 3/4" Dia. |
| F. Idler Pulley | |

Figure 26. Brake-Clutch Adjustment

2. Adjust brake rod as follows:

The clutch-brake pedal must be in up position. With one hand, push rod guide (C, figure 26) as far forward as slot (B) will allow while pulling rod (I) back with other hand. With rod guide in this position, tighten or loosen nut (A) until 1/4 inch (6.3 mm) of clearance is obtained between nut and end of spring.

3. Adjust clutch rod as follows:

- a. With the pedal up, push the idler pulley (F, figure 26) firmly against the belt. With the pulley in this position, the gap between nut (E) and the rod guide (G) should be 7/8 to 1 inch (22 to 25 mm). If not, tighten nut (E) to decrease gap or loosen nut to increase gap. Recheck the measurement.

- b. Depress and lock the clutch-brake pedal. Loosen the setscrew in the set collar (H). Move the collar against the spring which is located between collar (H) and rod guide (G). Be sure spring is seated as far as possible over rod guide (G). Tighten the set collar; the spring should be free to

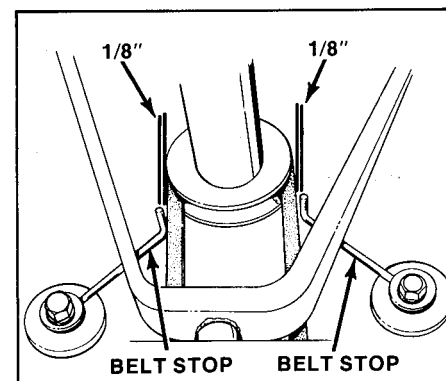

Figure 27. Drive Pulley Belt Stops

rotate. (When moving the set collar be careful not to move the rod.)

4. Adjust drive pulley belt stop as follows:

There should be 1/8 inch (3 mm) between each belt stop and the belt when the tractor clutch is engaged (pedal up). See figure 27.

MOWER ADJUSTMENTS**Mower Drive Belt Tension**

Using the mower lift lever, lower the mower.

Using the height control lever, place the mower in highest cutting position. Place the PTO lever in engaged position. The gap between the rod guide (A, figure 28) and the set collar (B) should measure 3/8 to 1/2 inch (10 to 13 mm). If not, disengage the PTO. Loosen the setscrew (C). Move the rod forward to increase the gap or back to decrease the gap then tighten the setscrew. Engage the PTO and recheck the adjustment. Readjust if necessary.

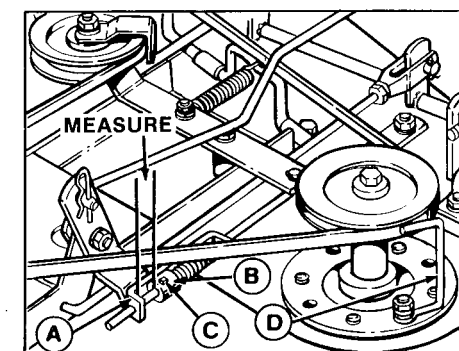

- A. Rod Guide
- B. Set Collar
- C. Setscrew
- D. Belt Stop

Figure 28. Drive Belt Tension

Adjustments

Arbor Belt Stops

The arbor belt stops are item D in figure 28 and item B in figure 29. There should be 1/8 inch (3 mm) clearance between the belt stops and belt when the PTO lever is engaged. If not, loosen the nut, move the belt stop and retighten the nut.

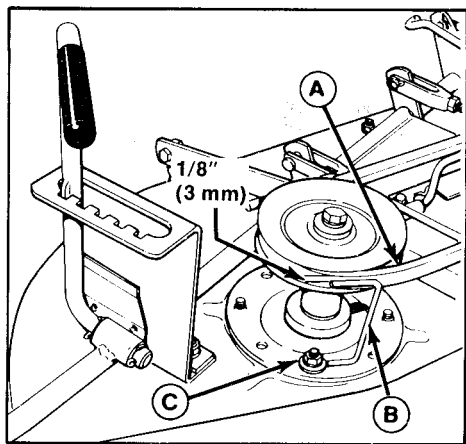

- A. Belt
- B. Belt Stop
- C. Nut

Figure 29. Right Arbor Belt Stop

Idler Pulley Belt Guide

The idler pulley belt guide is correctly adjusted when its edge is 1/4 inch (6 mm) from the rear edge of the idler arm (figure 30). If not, loosen the nut (C) and move the belt guide. Tighten the nut and recheck the measurement.

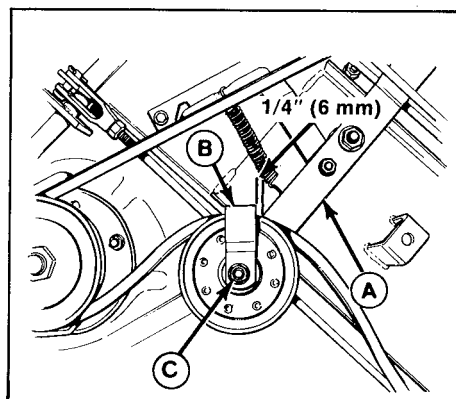

- A. PTO Idler Arm
- B. Belt Guide
- C. Nut

Figure 30. Idler Pulley Belt Guide

PTO Pulley Belt Stops

There are two belt stops at the PTO pulley; one on the left (figure 31) and one on the

right (figure 32). With the PTO lever engaged, measure the distance between the belt stop and belt. There should be 1/16 inch (1.5 mm) clearance between each belt stop and the belt. To adjust a belt stop, loosen its mounting capscrew, move the belt stop, and retighten the capscrew. Recheck the measurement.

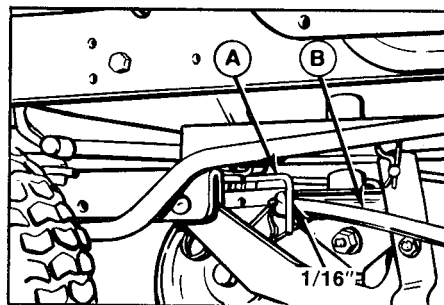

- A. Belt Stop
- B. Belt

Figure 31. Left PTO Pulley Belt Stop

Adjustments

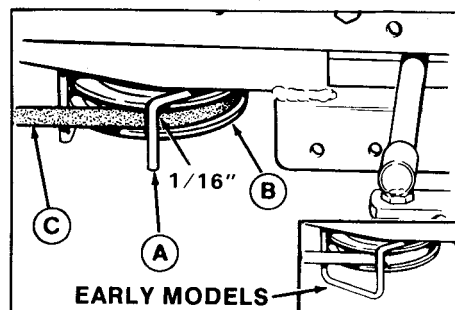

A. Belt Stop B. PTO Pulley C. Belt
Figure 32. Right PTO Pulley Belt Stop

Levelling The Mower

If the cut is uneven, the mower may need levelling. Unequal or improper tire pressure may also cause an uneven cut.



WARNING

To prevent accidental starting, remove the ignition key and then remove the spark plug wire and fasten it away from the spark plug.

1. With the mower installed, place the tractor on a smooth level surface, such as a concrete floor. Turn the front wheels straight forward.

2. Check for bent blades, and replace if necessary.
3. Disengage the PTO. Arrange the mower blades so that they are both pointing from side-to-side, perpendicular to the tractor. Engage the PTO.
4. Measure the distance between the outside tips of each blade and the ground. If there is more than 1/8 inch (3 mm) difference between the measurements on each side, proceed to step 5. If there is 1/8 inch (3 mm) or less difference proceed to step 6.
5. Remove the cotter pin (E, figure 33) which secures the mower levelling rod (D). Shorten the rod (D) to raise the left side of the mower or lengthen the rod to lower the left side of the mower. Put the levelling rod back in its hole and re-check the measurements. If the mower is level, install the cotter pin (E).
6. Disengage mower PTO to arrange the blades so they are facing front to back, parallel with the tractor. Engage mower PTO again.
7. Measure the distance to the ground from the front tip of the left blade and

the rear tip of the right blade. The measurements should be equal. If they are not, proceed as follows.

NOTE

One full turn of clevis will equal about 1/8 inch.

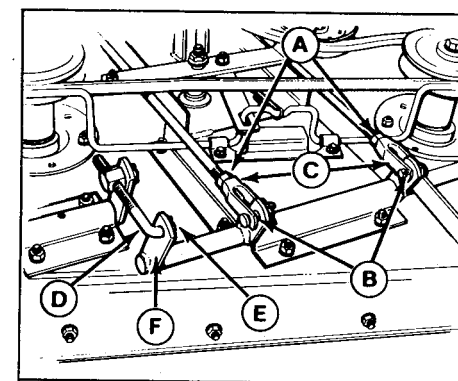

A. Jam Nuts
B. Pins
C. Hitch Clevises
D. Mower Levelling Rod
E. Cotter Pin
F. Suspension Arm

Figure 33. Levelling Mower

Adjustments

8. Remove the cotter pins and pins (B) from the hitch clevises (C). Loosen the two nuts (A). Turn each clevis an equal number of turns in the same direction. Shorten the hitch rods to raise the front of the mower or lengthen the hitch rods to lower the front of the mower.
9. Reinstall the pins through the clevises (C) and rear suspension arm (F) and recheck the measurements. When the mower is level, reinstall the cotter pins and tighten nuts (A) against clevises (C).

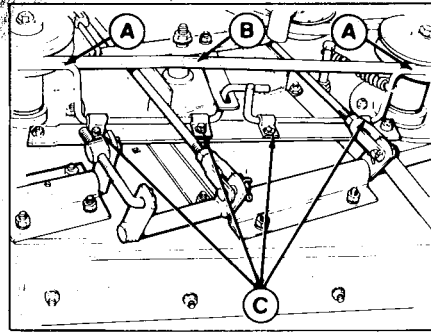

A. Blade Brake Rod
B. Belt
C. Mounting Brackets
Figure 34.

Blade Brake Adjustment

Inspect the mower deck with the mower attached and PTO rod released. The blade brake rods (A, figure 34) should firmly contact the belt (B) at the rear of the right and left arbor pulleys. There should be a shaft clearance between the two brake rods in the center.

To adjust blade brake rods, loosen the mounting brackets (C) and adjust rods for clearance. Retighten bracket bolts and check again. Engage the PTO and be sure that brake rods are at least 1/8" from belts.

SMALL LIFT LEVER

NOTE

Use this procedure if small lift lever (E, figure 8, page 7) is used. If optional large lift lever (B, figure 8) is used, go to next procedure.

1. Place the mower in low cut position. Using the lift lever, raise the mower.

2. Measure the distance between top of upstop bracket and bottom of footrest (figure 35). The measurement should be 2-13/16 inch.
3. To adjust, disconnect clevis (E) from chain. Loosen nut (A) and turn clevis to raise or lower mower. Reconnect chain to check measurement. When correct, tighten nut against clevis.

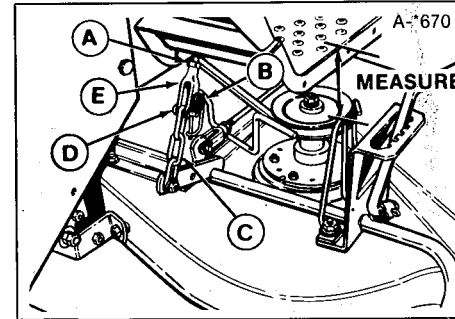

A. Nut **D. PIN**
B. Clip **E. Clevis**
C. Chain
Figure 35. Lift Assembly - Small Lift Lever

LARGE LIFT LEVER

NOTE

Use this procedure if optional large lift lever (B, figure 8, page 7) is used. If small lift lever (E, figure 8) is used, see previous procedure.

1. Place the mower in low cut position. Using the lift lever, raise the mower.
2. Measure the distance from bottom edge of lever bracket to mower deck (figure 36).

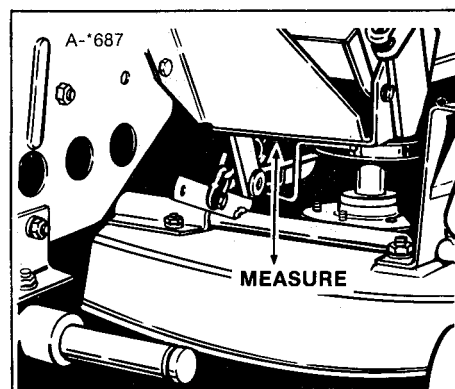
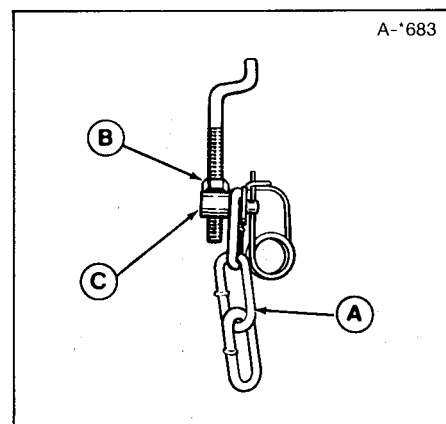

Figure 36. Measurement - Large Lift Lever

3. The measurement should be 5 inches.
4. To adjust, disconnect trunnion (C, figure 37) from lift chain. Loosen the nut, and turn trunnion to raise or lower mower. Tighten nut when measurement is correct.



- A. Chain
- B. Nut
- C. Trunnion

Figure 37. List Assembly - Large Lift Lever

Specifications

BASIC ENGINE

Make: Briggs & Stratton - 4 cycle, air cooled

Model & Type: See engine I.D. plate

Horsepower (8 HP): 8 HP @ 3600 rpm (Eng. Mfg's. Rating)

(11 HP): 11 HP @ 3600 rpm (Eng. Mfg's. Rating)

(12 HP): 12 HP @ 3600 rpm (Eng. Mfg's. Rating)

Cylinder: 1 horizontal

Bore & Stroke (8 HP): 3.00 x 2.75 inches (76 x 69 mm)

(11 HP): 3.44 x 2.62 inches (87 x 67 mm)

(12 HP): 3.44 x 3.06 inches (87 x 78 mm)

Displacement (8 HP): 19.44 cu. in. (319 cc)

(11 HP): 24.36 cu. in. (399 cc)

(12 HP): 28.4 cu. in. (465 cc)

Crankshaft: Vertical, syncrobalanced

Battery (8 HP): 12 volt, 32 amp. hour

(11 & 12 HP): 12 volt, 39 amp. hour

Governor: Mechanical, full throttle - no load setting

@ 3400 ± 100 rpm; idle speed @ 1750 ± 200 rpm

Crankcase Capacity: See engine manual

Ignition: Flywheel magneto with breaker points

Charging: Unregulated 3-amp DC charging circuit

Air Cleaner: Oil foam with reuseable polyurethane element

Fuel Tank: 2.2 gallons (8.3 liters) of "regular" grade
or nonleaded gasoline.

Starter: 12 volt electric gear drive

TRANSMISSION

Type: Spur gear trans. w/5 speed forward & 1 reverse

Differential: Bevel gear type

Ground speeds @3400 rpm:

1st Gear - .9 mph (1.5 km/h) **4th Gear** - 3.7 mph (5.0 km/h)

2nd Gear - 1.8 mph (2.9 Km/h) **5th Gear** - 4.0 mph (6.4 Km/h)

3rd Gear - 2.6 mph (4.2 Km/h)

Reverse - 1.9 mph (3.4 Km/h)

DIMENSIONS & WEIGHT

Height (at steering wheel): 39.7 (1008 mm)

Width: 34.25 in. (840 mm)

Length: 63 in. (1600 mm)

Clearance - Front Axle: 9 in. (228.6 mm)

Clearance - Transmission: 6 in. (152.4 mm)

Wheel Base: 45.5 in. (1156 mm)

4208 Turning Radius: 24 in. (610 mm)

4211 & 4212 Turning Radius: 24.5 in. (622 mm)

4208 Front Tires: 13 x 5.00 x 6 Pneumatic

4211 & 4212 Front Tires: 15 x 6.00 x 6 Pneumatic

4208 Rear Tires: 18 x 8.50 x 8 Pneumatic

4211 & 4212 Rear Tires: 18 x 8.50 x 8 Pneumatic

Weight: 4208 w/36" Mower: 390 lbs. (177 kg)

4211 w/36" Mower: 411 lbs. (186 kg)

4212 w/36" Mower: 411 lbs. (186 kg)

Common Replacement Parts

Listed below are part numbers for the more common replacement parts. Use the order form at the back of the manual to order a complete, illustrated parts manual. Only genuine Simplicity replacement parts will assure optimum performance and safety. Do not attempt repairs or maintenance unless proper procedures and safety precautions are followed. For assistance in any area, see your dealer.

| QTY PER UNIT | DESCRIPTION | PART NUMBER |
|--------------------|--------------------------------------|----------------|
| 1 | Drive Belt - Engine to Transmission | 166698 |
| 1 | Drive Belt - Mower | 108505 |
| 1 | Keys - Ignition (2 Keys with Ring) | 122203 |
| 2 | Headlight Lens | *1665933 |
| 2 | Blade - Mower (Standard) | 1657589 |
| 3 | Cotter Pin - Leveling Clevises & Rod | 918447 |
| 1 | Spring Clip - Mower PTO Rod | 106787 |
| 1 | Cotter Pin - Mower PTO Rod | 918448 |
| 2 | Hitch Pin - Mower | 156306 |
| 2 | Safety Clips - for Hitch Pins | 176012 |
| 1 | 39 Amp Hr. Battery | 1685215 |
| 1 | Fuel Filter | 173206 |
| 1 | Interlock Seat Switch (Early Models) | 1671703 |
| 1 | Interlock Seat Switch (Later Models) | 1700636 |

*Purchase bulb (#199) from a local automotive supplier.

**See your dealer to buy individual quarts.

| QTY PER UNIT | DESCRIPTION | PART NUMBER |
|--------------------|---|---------------------------------|
| | Simplicity SAE5W-30 Cold Weather Engine Oil | 1685518 (case of 12 qts.) |
| | **Multi-Purpose Hydraulic/ Transmission Oil | 1685516 (case of 12 qts.) |
| | Grease Gun Kit | 1685510 |
| | 8 Oz. Tube - for above | 103077 |
| | Touch-Up Paint | |
| | Orange Spray Paint, 13 Oz. Can | 1685558 |
| | Powder Orange Spray Paint, 13 Oz. Can | 1685589 |
| | White Spray Paint, 13 Oz. Can | 103049 |
| | Touch-Up Daubers | |
| | Regular Orange | 1685562 |
| | Powder Orange | 1685593 |
| | <i>(6 orange & 6 white - see your dealer for individual daubers.)</i> | |

Pneumatic Tire Seal - Stops Leaks

Available in following amounts:

| | |
|-------------------------|---------|
| 11 Oz. Tube | 1685523 |
| Case of 24-11 Oz. Tubes | 1685525 |

Optional Attachments

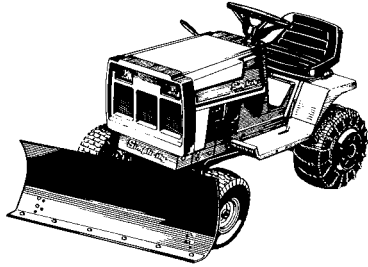

42" DOZER BLADE - For snow removal and light dozing of dirt, gravel, etc.

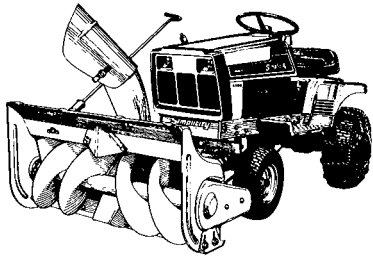

36" SNOWTHROWER - Efficient single stage operation to handle the heaviest of snows.

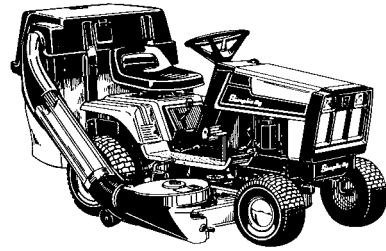

Turbo Collection Systems - Collect grass clippings, thatch, and leaves with powerful turbo collector. Can be used with 6.5 bu. twin bag collector (shown above), 10 bu. dump cart, or QuadBagger™. Engine-driven vac collector available for larger grass and leaf collection jobs.

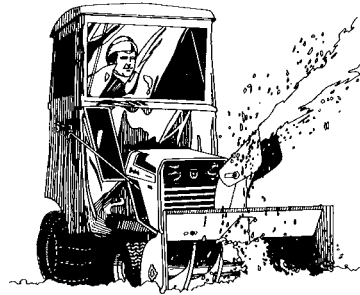

SNOW CAB - Shields operator from blowing snow and wind.

Optional Accessories

TIRE CHAINS for traction.

HOURLY METER to record operating time.

HEADLIGHTS to improve visibility.

SEAT SPRING KIT for operator comfort.

FRONT WEIGHT to improve steering and stability with rear mounted attachment.

REAR WHEEL WEIGHTS to improve traction and stability.

DUMP CART for vacuum collector and hauling chores.

ROVING NOZZLE used with vacuum collector to collect leaves in hard-to-reach places.

NOTE: Some attachments require accessories. See your dealer or the attachment operator's manuals.

PARTS MANUALS AVAILABLE FOR 4200 SERIES

Simplicity Parts Manuals are fully illustrated. All of the assemblies are shown in exploded views which show the relationships of the parts and how they go together. Important assembly notes and special torque values are included in the illustrations. For standard hardware, a torque specifications chart is required.

A Parts Manual is available for the 4200 Series tractors and mowers. A separate Parts Manual is available for major attachments and service accessories for the tractors.

It is very important that you provide your tractor and mower **Mfg. No.** when ordering manuals.

To order enclose the form with a check or money order made out to SIMPLICITY. Address the envelope to:

Simplicity Manufacturing, Inc.
Attn: Cashier
500 N. Spring Street
P.O. Box 997
Port Washington, WI 53074-0997

REPAIR MANUAL AVAILABLE

A Do-It-Yourself Repair Manual is available from your dealer. This manual contains fully illustrated step-by-step instructions for complete maintenance, troubleshooting, and repair.

CUT HERE

- I would like a Parts Manual for my tractor and mower. Enclosed is a check or money order for \$5.50.
- I would like a Parts Manual for major attachments and accessories. Enclosed is a check or money order for \$5.50.
- I would like a Repair Manual for my tractor and mower. Enclosed is a check or money order for \$8.00
- Please include \$1.50 for shipping and handling.

NOTE: Tractor and mower manufacturer's numbers must be included.

Tractor Mfg. No. _____ Mower Mfg. No. _____

Name _____

Street or RFD _____

City _____ State _____ Zip _____

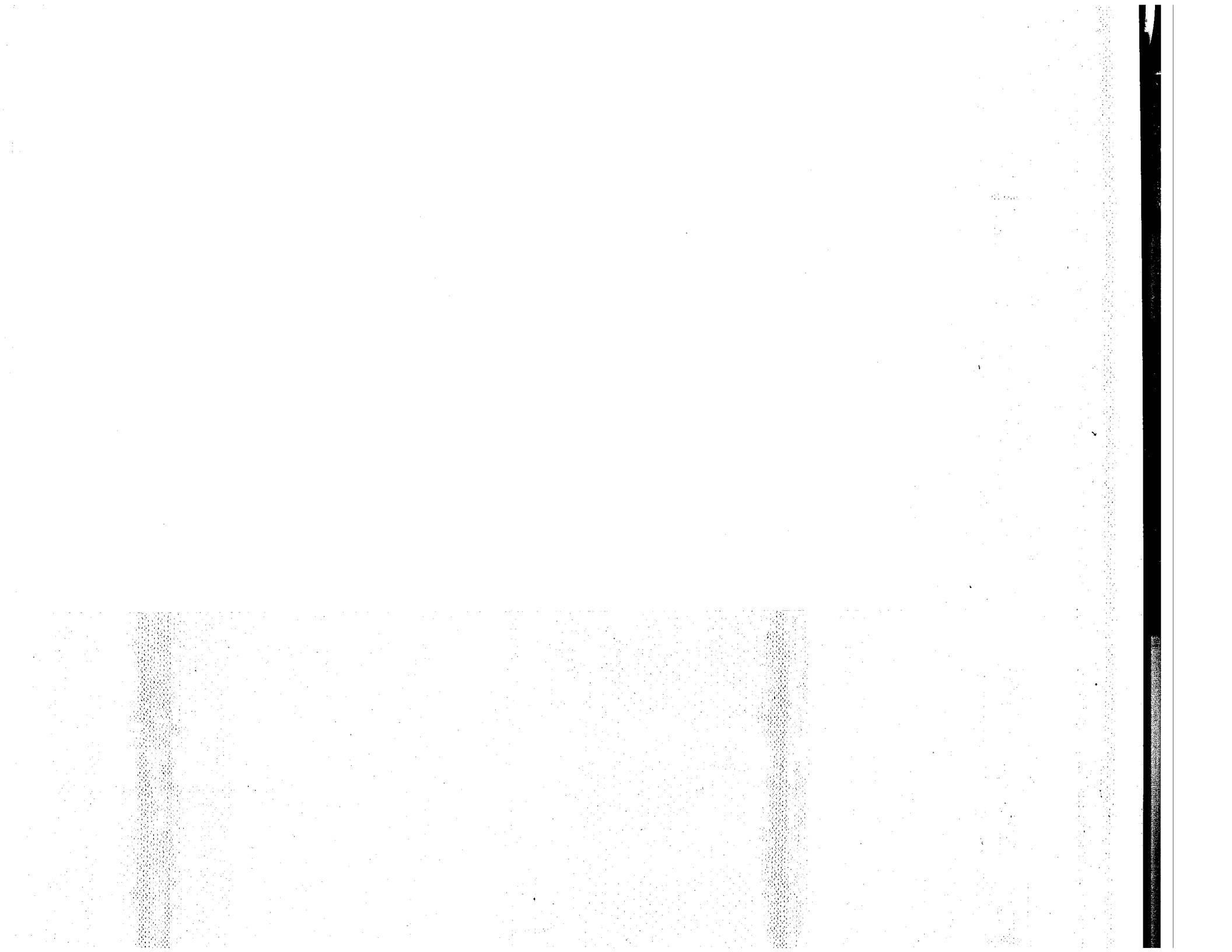

50-43707-1000
A. C. W. BIRTHDAY
0000 1000

SIMPLICITY MANUFACTURING, INC.

500 N. Spring St., P.O. Box 997
Port Washington, WI USA 53074-0997

FORM 1701724-02
PRINTED IN U.S.A.
©1990 6/90