

Safety Instructions & Operator's Manual for

SNAPPER®

**LT120G30AB, LT125G38AB,
LT140G38ABV, LT140G42AKV &
LT150G42AKV SERIES "A"
LAWN TRACTORS**

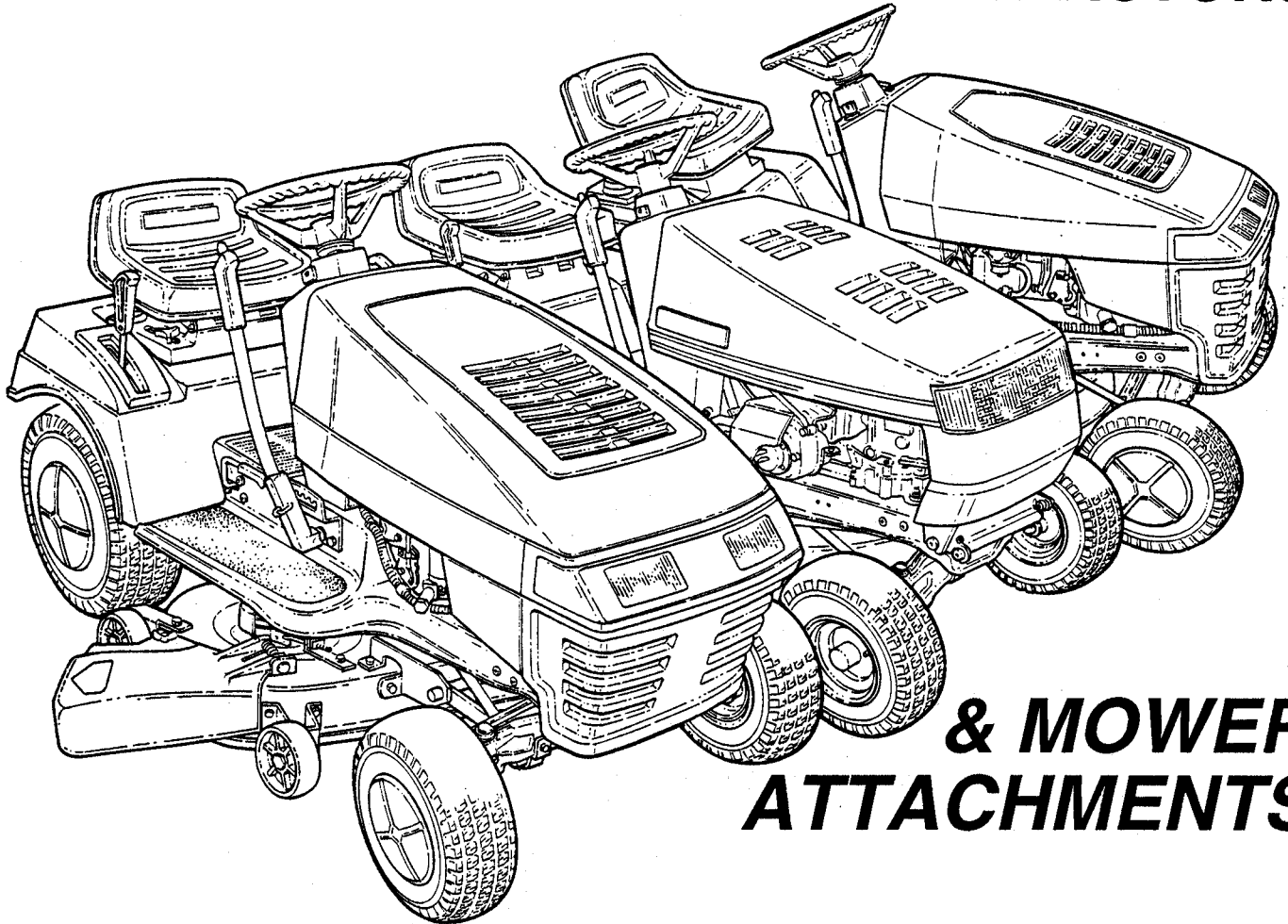

**& MOWER
ATTACHMENTS**

*Thank you for buying a **SNAPPER** product! Before operating your mower, read and follow the Important Safety Instructions (on Page 2), the other instructions contained in this manual and the accompanying booklet, "About Power Mower Safety". Lawnmowers, and all power equipment, can be potentially dangerous if used improperly. REMEMBER: SAFETY REQUIRES CAREFUL USE IN ACCORDANCE WITH INSTRUCTIONS AND COMMON SENSE.*

SNAPPER®McDonough, GA., 30253 U.S.A.

MANUAL No. 2-4685 (REV. 3, 12/93)

IMPORTANT SAFETY INSTRUCTIONS

WARNING: This powerful cutting machine is capable of amputating hands and feet and can throw objects that can cause injury and damage! Failure to observe the following SAFETY instructions could result in serious injury or death. Carefully read this manual and question your dealer if something is not clear. Should the dealer be unable to answer to your satisfaction, write or call the Customer Service Department at SNAPPER, McDonough, Georgia, 30253 (Phone 404-954-2500).

PROTECTION FOR CHILDREN

1. DO NOT allow children in yard when machine is operated (even with the blade OFF).
2. DO NOT allow children to ride on machine or on attachments (even with the blade OFF).
3. DO NOT allow per-teenage children to operate machine.
4. Only responsible teenagers with mature judgement shall be allowed to operate machine and only under close supervision.

PROTECTION AGAINST TIPOVERS

1. DO NOT operate machine on slopes exceeding 15 degrees (27% grade).
2. On slopes above 10 degrees (18% grade), exercise extreme CAUTION. Turn blade OFF when traveling uphill, also reduce speed and avoid sharp turns.
3. Avoid uphill starts. If machine is stopped going uphill, turn blade OFF and back slowly down the slope.
4. DO NOT mow under any condition where traction or stability is doubtful without first test driving over the terrain with blade OFF.
5. Stay alert for holes and other hidden hazards. Keep away from ditches, washouts, culverts, fences and protruding objects.
6. DO NOT mow back and forth across face of slopes.
7. KEEP A SAFE DISTANCE (at least three feet) away from edge of ditches and other drop offs.

OTHER IMPORTANT PRECAUTIONS

1. Read and follow operator's manuals and instructions furnished with attachments.
2. Only mature, responsible persons shall operate the machine.
3. Mount and dismount the machine from left side.
4. Wear appropriate protective clothing when mowing, such as, long pants and substantial footwear, not barefoot or with open sandals.
5. Practice operation of machine with blade OFF to learn controls and develop skill.
6. Persons under the influence of alcohol or drugs must NOT operate machine.
7. Know how to STOP blade and engine quickly in preparation for emergencies.

8. Keep people and pets a safe distance from machine.
9. Shields, deflectors, switches, blade controls and other safety devices must be in proper position and functional.
10. Clear area to be worked of wire, rocks and other objects that could cause injury if thrown by blade.
11. STOP blade, STOP engine and remove key when leaving machine.
12. DO NOT operate machine unless properly seated with feet on foot rests or pedal.
13. Keep hands and feet away from rotating blade underneath deck. Never place foot on ground while blade is ON or when machine is in motion.
14. Turn blade OFF, STOP engine and wait for blade to STOP before attempting to unclog grass or leaves to prevent loss of fingers or hand.
15. Blade must be switched OFF except when cutting grass. Set cutter in highest position when mowing over rough ground.
16. Deflector or grass catcher must be in position. Never point discharge at people, passing cars, windows or doors. Watch out for traffic when crossing or near roadways.
17. Operate in reverse only after careful observation of entire area behind the machine. DO NOT mow in reverse unless absolutely necessary.
18. Service machine and make adjustments only when engine is stopped.
19. Have machine serviced by an authorized SNAPPER dealer at least once a year and have the dealer install any new SAFETY devices.
20. Use only genuine SNAPPER replacement parts to assure that original standards are maintained.
21. Tighten all nuts, bolts and screws frequently, then check, adjust, repair or replace brakes as needed.
22. Lubricate machine at intervals specified in manual to prevent controls from binding.
23. Mow only in daylight or with good artificial light.
24. Handle gasoline with care! Never remove cap while engine is running. Fill tank outdoors only with engine STOPPED and cool. Clean spilled gasoline from machine. Store gasoline in approved container, out of the reach of children, in well ventilated, unoccupied building.
25. DO NOT change engine governor speed settings or overspeed engine.
26. Check grass catcher components frequently for signs of wear or deterioration and replace as needed to prevent injury from items going through weak or worn spots.
27. Exercise CAUTION when pulling loads. Limit loads to those you can safely control and attach loads to hitch plate as specified with SNAPPER attachment instructions.

FAMILIARIZATION

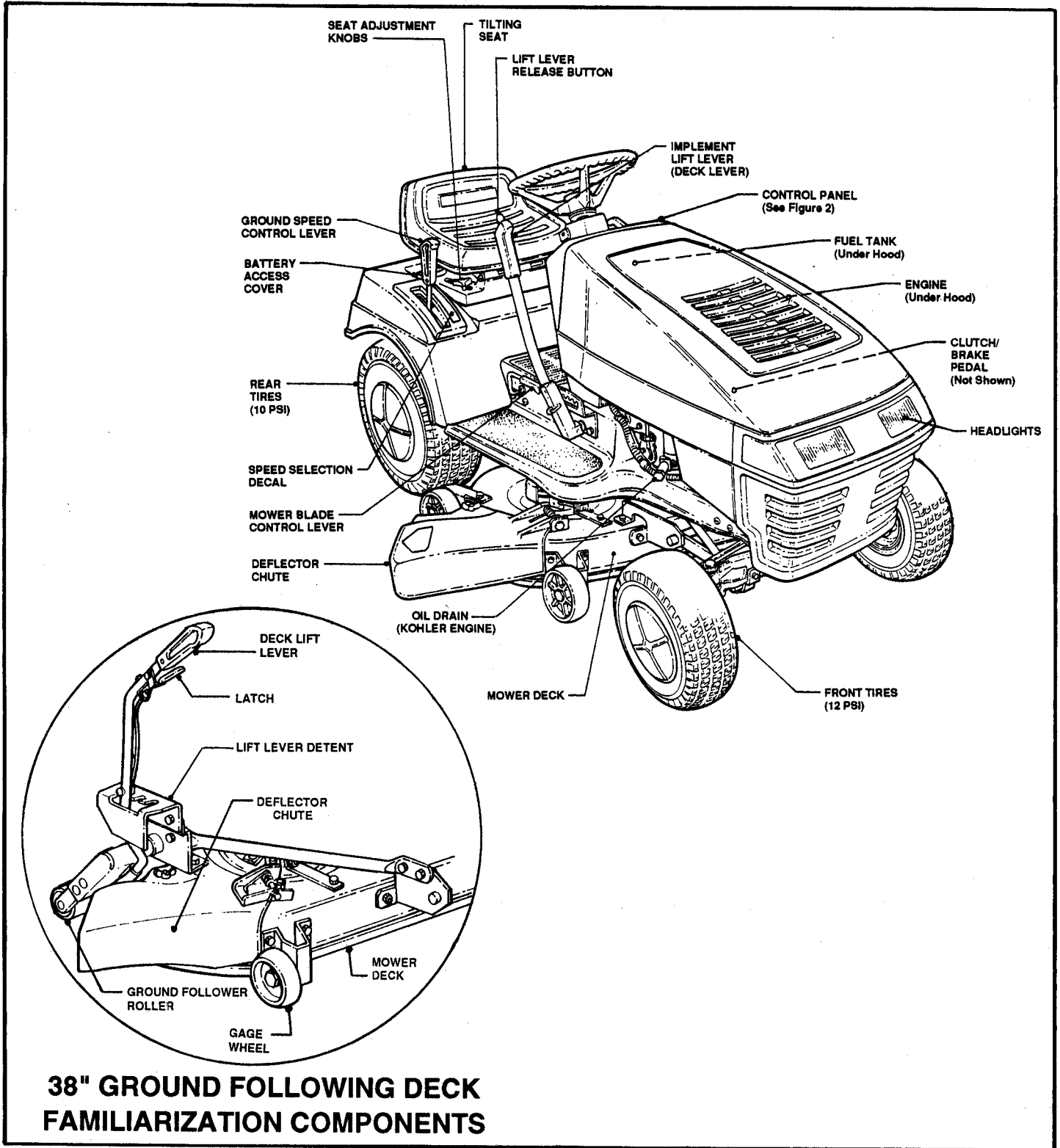

FIGURE 1

INTRODUCTION

This manual has been prepared for the operators of the SNAPPER LT Series LAWN TRACTORS. Its purpose, aside from recommending operating and routine service requirements, is to promote safety through the use of accepted operating practices. **Read, Understand and Follow** the SAFETY PRECAUTIONS on Page 2 of this manual and all safety messages on the tractor and attachments before operating the machine.

NOMENCLATURE

The nomenclature drawing above (Figure 1) shows the essential parts of the SNAPPER LT Series LAWN TRACTOR. It is recommended that all operators of this equipment become thoroughly familiar with the controls, parts and operation of this machine before operating. Specific details involving the engine are found in the separate engine owner's manual. Study these manuals before operating and keep both handy for future reference.

OPERATING INSTRUCTIONS

STOPPING

ENGINE: STOP ENGINE by turning the KEYSWITCH to "OFF". See Figure 2.

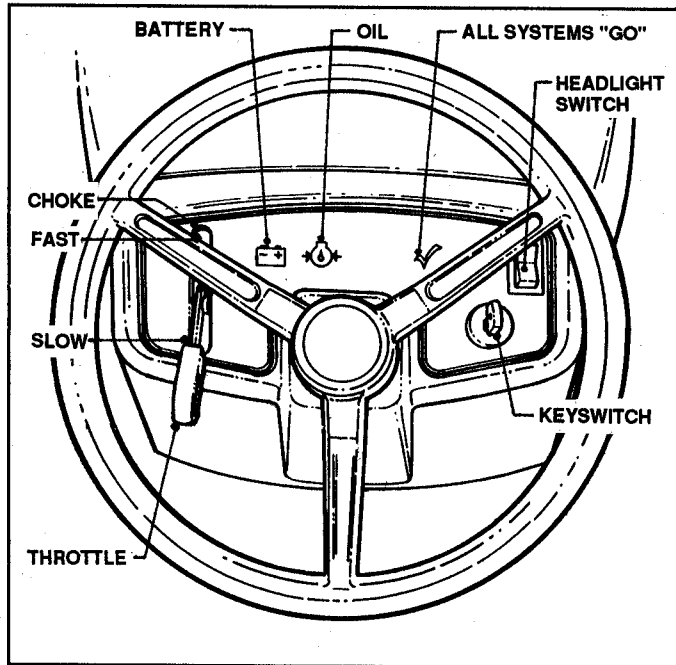

FIGURE 2

WHEEL DRIVE: STOP FORWARD MOTION of mower by pushing CLUTCH/BRAKE PEDAL all the way "DOWN". See Figure 3.

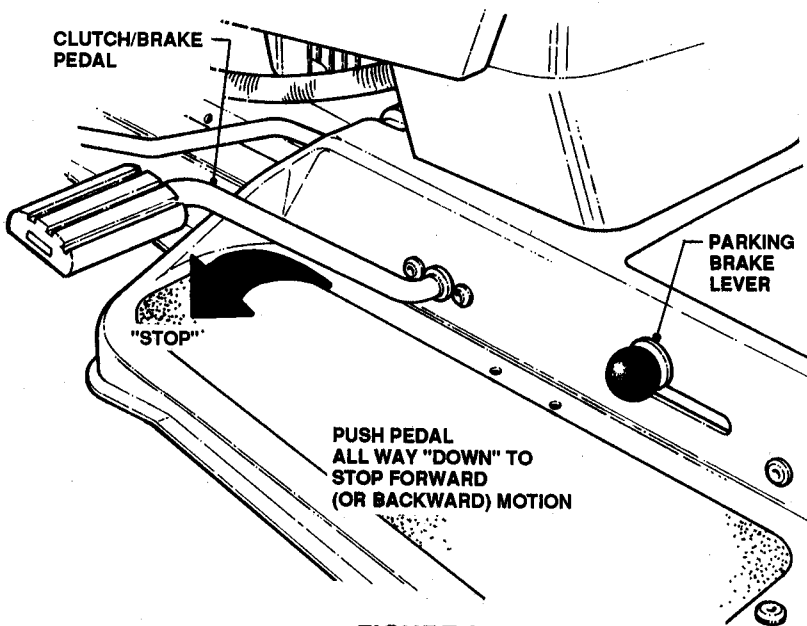

FIGURE 3

MOWER BLADE: STOP MOWER BLADE by pushing BLADE CONTROL LEVER downward to "OFF". See Figure 4.

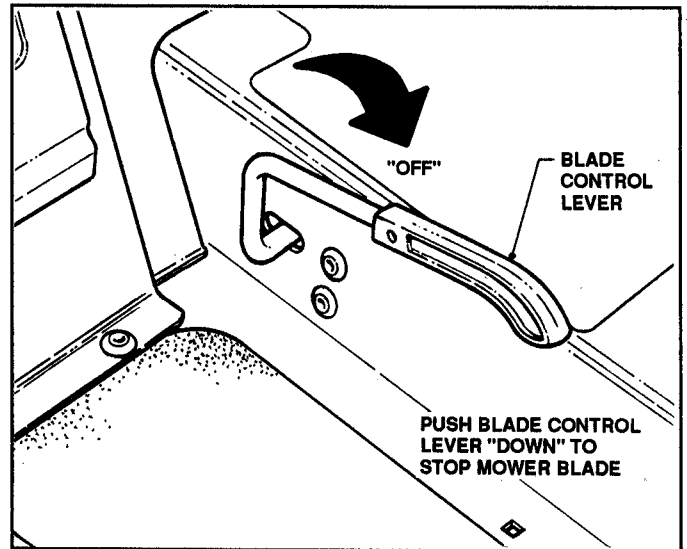

FIGURE 4

PRE-START CHECK LIST

Make the following checks and perform the service as required before each startup.

- CHECK TIRES and add air as needed to bring pressure to 12 psi in front and 10 psi in rear tires.
- CHECK GUARDS, DEFLECTORS & COVERS to make sure all are in place and securely tightened.
- CHECK ENGINE OIL and add oil as needed to bring level up to (but not over) the full mark. (Refer to Engine Manual for oil specifications).
- READJUST SEAT as needed to most comfortable position. (Refer to Page 5).
- CHECK BLADE CONTROL to insure it works freely. Blade lever must be moved manually from "ON" to "OFF" to stop blade.
- CLEAN EXTERIOR SURFACES of cutting deck and engine of any accumulation of dirt, grass, oil etc. Keep engine air intake screens and cooling fins clear at all times.
- ADD FUEL to tank after pushing the mower outside where fumes can be dissipated. Make sure cap is tightened after refueling. (Refer to Engine Manual for fuel specifications). See Figure 5.

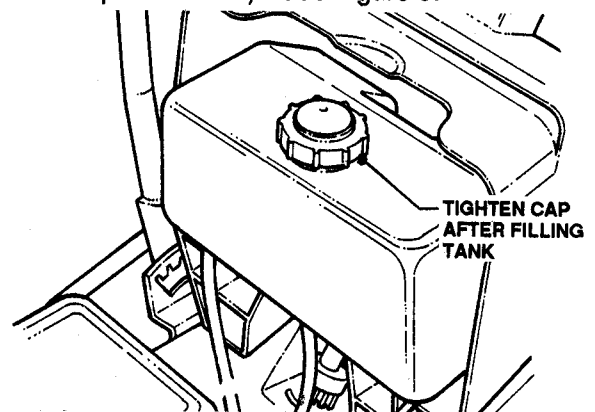

FIGURE 5

OPERATING INSTRUCTIONS

TO ADJUST OPERATOR'S SEAT

FRONT TO REAR ADJUSTMENT: With engine stopped, loosen the **ADJUSTING KNOBS** on seat support. Sit in Operator's seat and, while depressing the **CLUTCH/BRAKE PEDAL**, slide the seat forward or rearward to the most comfortable position, then lock in position by tightening **ADJUSTING KNOBS**. See Figure 6.

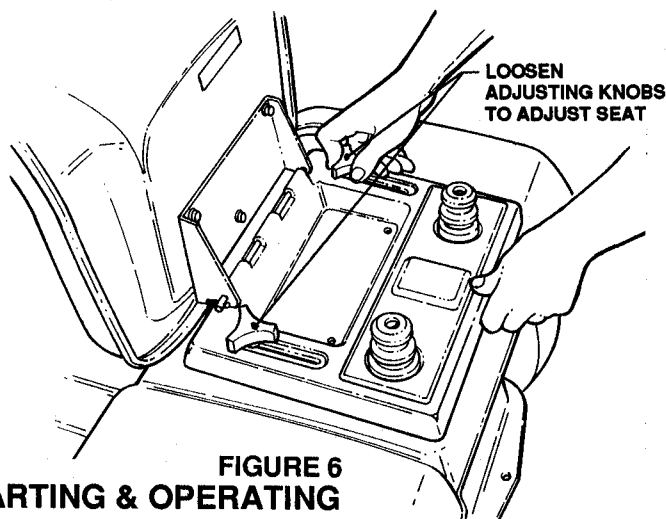

FIGURE 6

STARTING & OPERATING

ENGINE: START ENGINE as follows:

1. Take a comfortable position in seat of riding mower. Look around - make sure that area you are going to mow is clear of people, children and pets. Take note of any stationary obstacles!
2. **PUSH BLADE CONTROL LEVER** downward to "OFF" position (Figure 4) and fully depress the **CLUTCH/BRAKE PEDAL** (Figure 3), so that Safety Interlock System will allow engine to start.

NOTE

The Seat Interlock will shut off the engine if the Operator gets off the seat while the tractor is in gear or if the blade is running. If the Interlock ever fails to work, then **DO NOT OPERATE** the tractor until the Interlock has been repaired.

3. **CHOKE ENGINE** for cold starting by moving **THROTTLE CONTROL** to "CHOKE" position. (Little or no choking will be needed when re-starting a warm engine). Refer to Figure 2.
4. Insert key in **ENGINE IGNITION SWITCH**, turn key to "START" position to crank engine and hold until engine starts, then release.

NOTE

DO NOT crank engine for more than five seconds at a time. This will help prevent the starter from overheating and/or running down the battery. If cranking time is more than five seconds, locate and correct cause of starting problem.

5. **WARM-UP ENGINE** momentarily, then move the **THROTTLE CONTROL** downward out of "CHOKE" position until engine runs smoothly. Set desired speed. Best cutting and bagging performance is obtained with engine at or near top speed.

TO START MOTION

After the engine has been started and is running smoothly, proceed as follow to start forward or rearward motion.

1. Push the **CLUTCH/BRAKE PEDAL** all way down and shift **SPEED SELECTOR** to 1 to go forward or to R for reverse. See Figure 7.

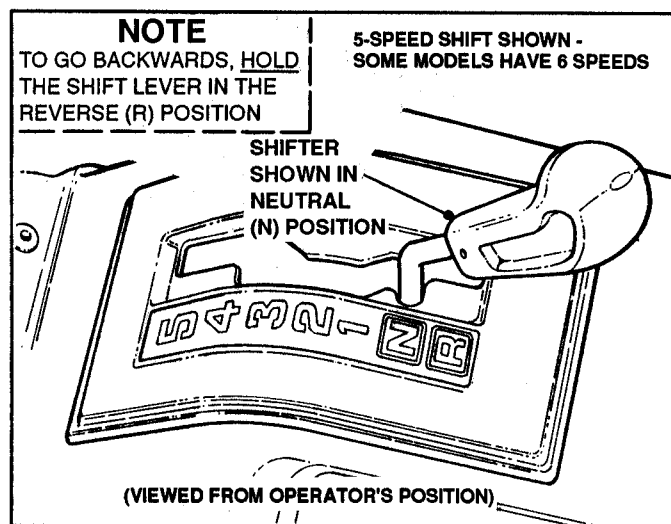

FIGURE 7

2. Slowly release **CLUTCH/BRAKE PEDAL** to start mower in motion.
3. Drive the mower around the yard. Stay in lower forward gear until you become familiar with the mower's steering and stopping characteristics.
4. Push the **CLUTCH/BRAKE PEDAL** half way down to shift gears "On - The - Go".
5. Push the **CLUTCH/BRAKE PEDAL** all way down and come to a complete stop before shifting into reverse (R).

TO STOP MOTION

Push **CLUTCH/BRAKE PEDAL** all the way down to stop forward or rearward motion. See Figure 8.

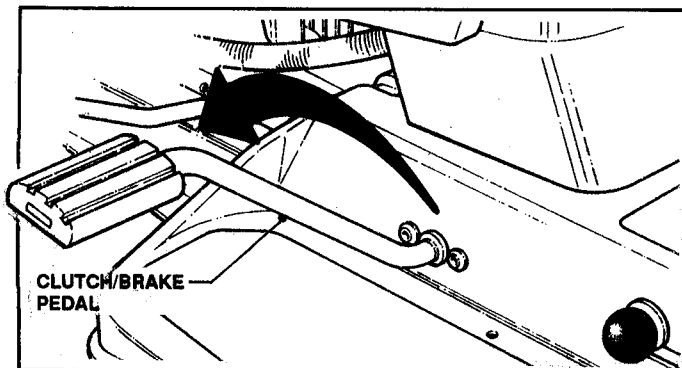
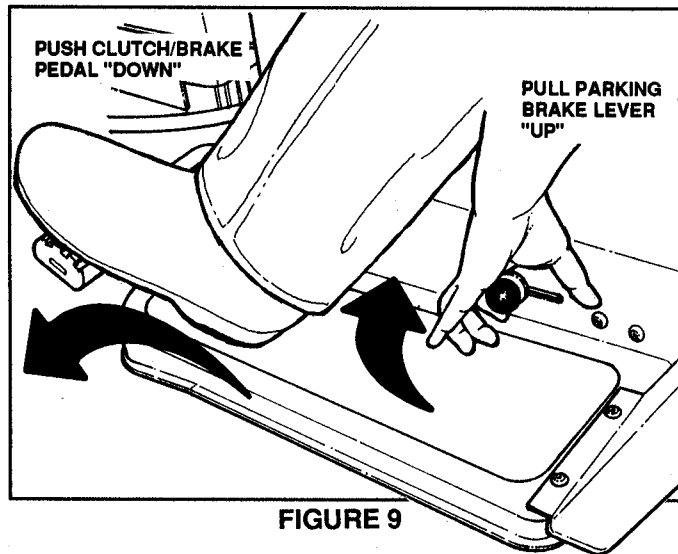

FIGURE 8

OPERATING INSTRUCTIONS

TO SET PARKING BRAKE

Depress CLUTCH/BRAKE PEDAL. Pull PARKING BRAKE LEVER "UP" while releasing pedal. See Figure 9.



Push CLUTCH/BRAKE PEDAL down to release PARKING BRAKE.

TO ROLL MACHINE

Shift SPEED SELECTOR to "N" position or hold CLUTCH/BRAKE PEDAL half down.

TO OPERATE MOWER

During transport or for clearance through gates, it may become necessary to raise the DISCHARGE DEFLECTOR. Reinstall the wingnut on the studs when the DEFLECTOR is raised, so they will not be lost. Be sure to lower the DEFLECTOR and clamp it securely down with the wingnuts before mowing. See Figure 10.

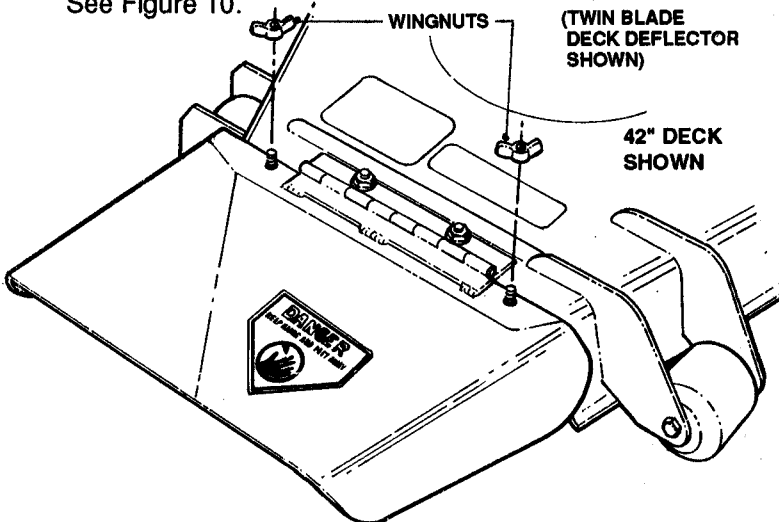

FIGURE 10

TO ADJUST CUTTING HEIGHT

The cutting height can be changed to any one of six positions by raising or lower the Cutting Deck Attachment with the IMPLEMENT LIFT LEVER as shown in Figure 11.

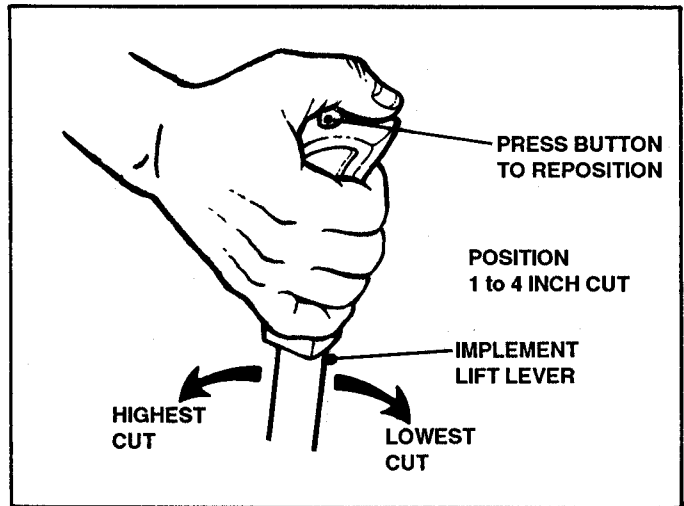

FIGURE 11

To suit mowing conditions, experiment by increasing engine speed and/or decreasing driving speed until smoothest cut is obtained without placing engine under a heavy strain.

TO START MOWER BLADE

START MOWER BLADE by pulling BLADE CONTROL LEVER "UP" to "ON". See Figure 12.

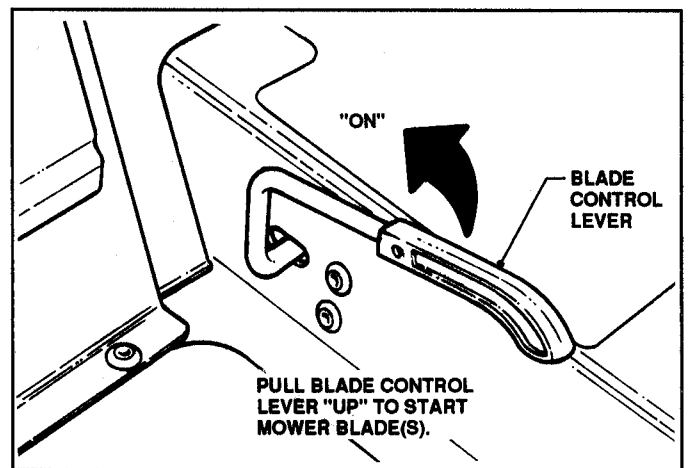

FIGURE 12

⚠ DANGER ⚠
Do Not Operate Mower Without Discharge Deflector in "DOWN" Position and Clamped Securely With Wingnuts.

⚠ CAUTION ⚠
Avoid Uphill Starts! If Machine is Stopped Going Up Slope, Push Blade Control Lever Downward to "OFF" Position and Back Slowly Down Slope. If Uphill Start Must Be Made, Push Blade Control Lever Downward to "OFF" and Set Throttle at Half Speed.

OPERATING INSTRUCTIONS

NOTE: The following pages, 7 and 8, are for the LT140G38AKV Model Lawn Tractor with the 38" Ground Following Deck only.

TO OPERATE MOWER:

During transport or for clearance through gates it may become necessary to raise the DISCHARGE DEFLECTOR. Reinstall the wing nut on the stud when the DEFLECTOR is raised so it will not be lost. Be sure to lower the DEFLECTOR and clamp it securely down with the wing nut before mowing. See Figure 13.

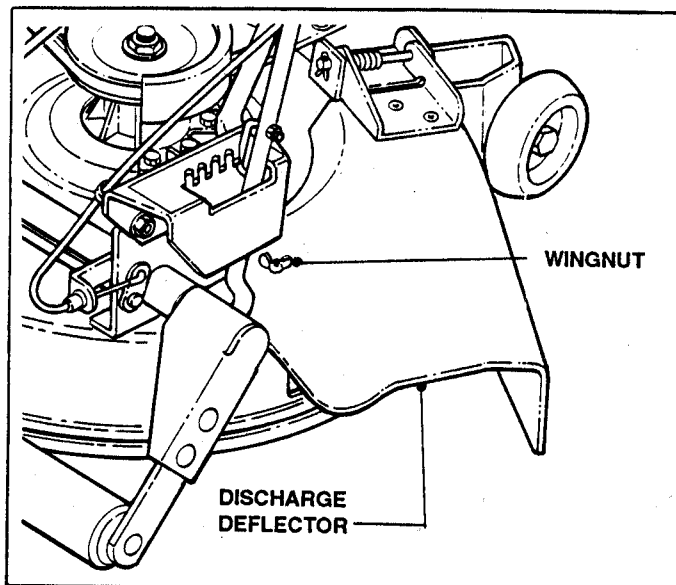

FIGURE 13

TO ADJUST CUTTING HEIGHT

The cutting height can be changed to any one of five positions by raising or lowering the cutting deck with the DECK LIFT LEVER as shown in Figure 14.

To suit mowing conditions, experiment by increasing engine speed and/or decreasing driving speed until smoothest cut is obtained without placing engine under a heavy strain.

TO START MOWER BLADE

START MOWER BLADE by pulling BLADE CONTROL LEVER "UP" to "ON".

TO BE ABLE TO GET OFF MOWER AND LEAVE ENGINE RUNNING:

1. Push BRAKE all way down.
2. Set PARKING BRAKE.
3. Push BLADE CONTROL LEVER "DOWN" to "OFF" position.

NOTE
DO NOT ENGAGE LATCH WHEN MOVING DECK LIFT LEVER TO SELECT CUTTING HEIGHT!!

PUSH "OUT" ON HANDLE AND MOVE LEVER TO DESIRED HEIGHT OF CUT.

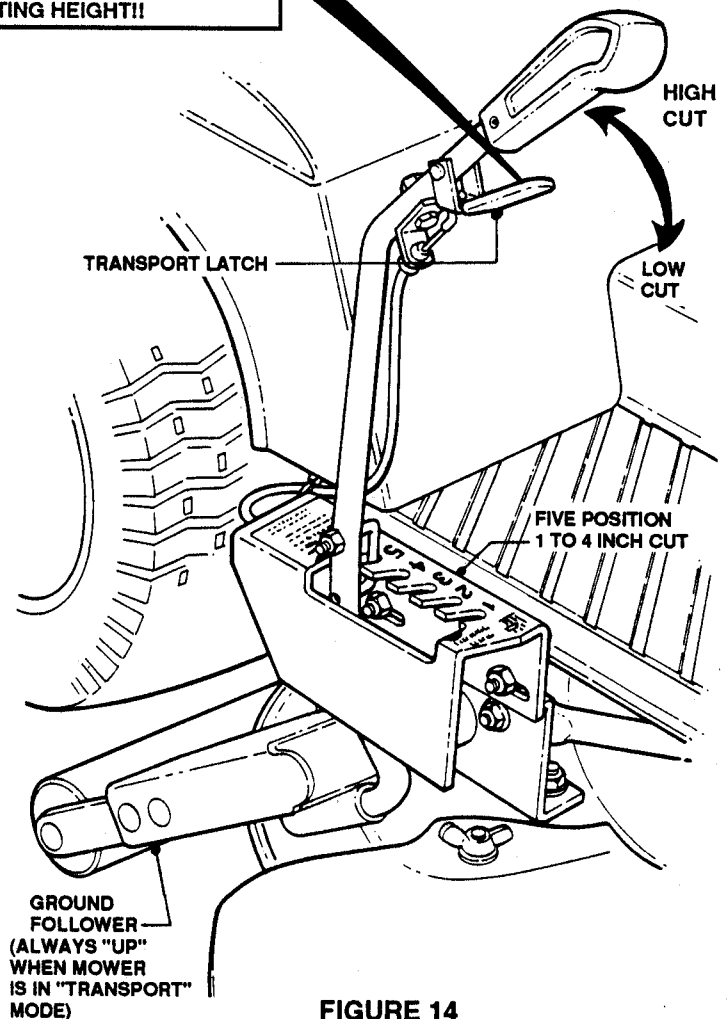

FIGURE 14

TO TRANSPORT MOWER

The cutting deck of this mower is designed to follow the terrain of the area being mowed. This is accomplished by the deck roller (located behind the mower deck) which, by being in contact with the ground, controls the cutter deck in following the contour of the ground and thereby cutting the grass at the same level in all spots. The roller should be moved to the "UP" position when transporting the mower across gravel, pavement, concrete, etc. Also, the blade control should be in the "OFF" position during transport. To put the deck in Transport position, proceed as follows:

1. Pull deck lift lever back to LATCH POSITION. See Figure 15.

OPERATING INSTRUCTIONS

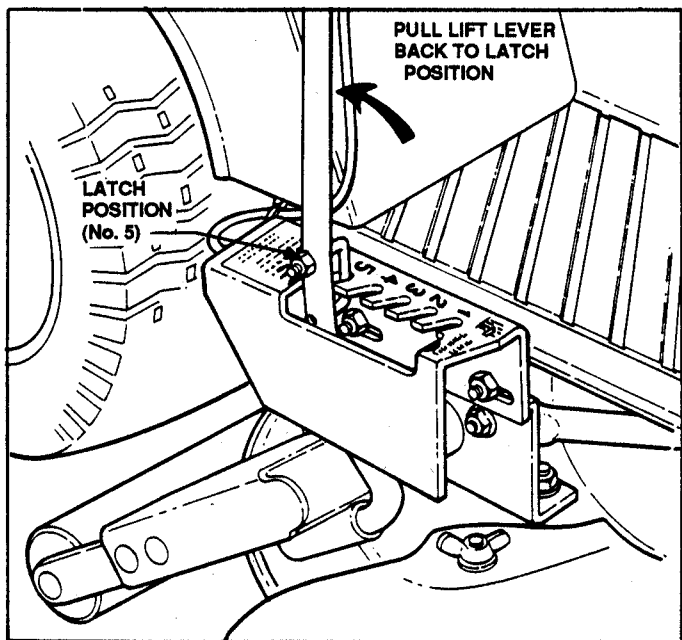

FIGURE 15

CAUTION!
Push **BLADE CONTROL LEVER "DOWN"** to "OFF" position before transporting mower.

OIL PRESSURE LIGHT (On Dash)

During operation, if the OIL PRESSURE LIGHT should begin to glow, then the engine should be stopped immediately and the oil level checked. If oil is low, add oil until dipstick is correct. If the problem is not the oil level, take the mower to your nearest SNAPPER Dealer for inspection or repair.

2. Depress latch and lower lift lever to TRANSPORT POSITION. See Figure 16.

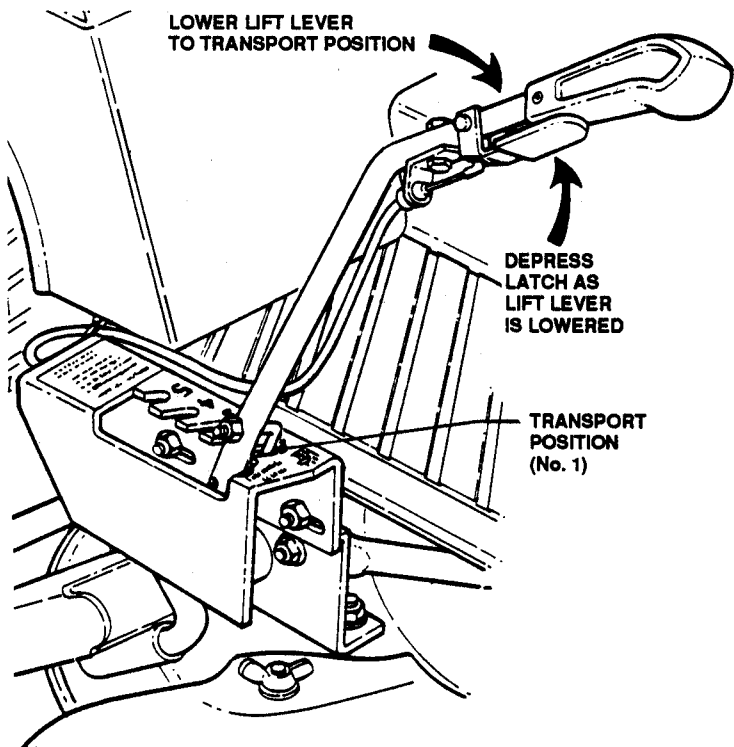

FIGURE 16

3. Release latch and handle to lock mower deck into TRANSPORT POSITION.

OPERATING INSTRUCTIONS/SERVICE

TO BE ABLE TO GET OFF MOWER AND LEAVE ENGINE RUNNING:

1. Push CLUTCH/BRAKE PEDAL all way down.
2. Set PARKING BRAKE.
3. Push BLADE CONTROL LEVER "DOWN" to "OFF" position. Refer to Figure 4.
4. Move shift SPEED SELECTOR to neutral (N).

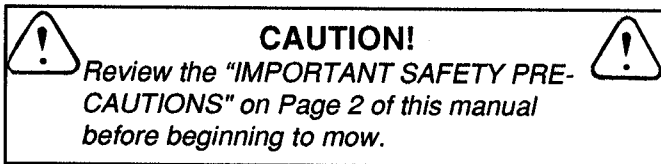
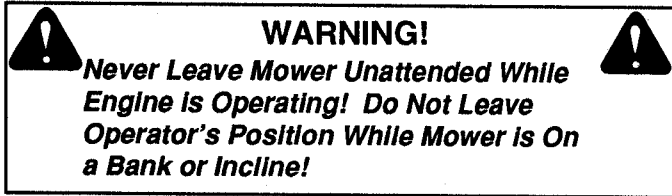

SERVICE

To retain the quality of your tractor, use Genuine SNAPPER Replacement Parts only. Contact your local SNAPPER Dealer for parts and service assistance. For the correct part or information for your particular mower, always mention model and serial number. We recommend returning the tractor to an authorized SNAPPER Dealer on a yearly basis for inspection and addition of any new devices which might upgrade the safety of your mower. For the nearest SNAPPER Dealer, check the yellow pages under the heading LAWN MOWERS. For engine parts and service, look for the engine manufacturer's dealers under the heading ENGINES - gasoline.

MAINTENANCE & LUBRICATION SCHEDULE

Except for changing oil, refer to the Engine Owner's Manual for service specifications on the engine itself. The following applies primarily to the tractor and mower attachments. Clean fittings before greasing.

FIRST 5 HOURS (NEW UNIT)

- **ENGINE:** Change oil in crankcase. Refer to Engine Owner's Manual, and Changing Engine Oil Instructions on this page.
- **TRACTOR:** Check all fasteners and retighten as needed.
- **MOWER DRIVE BELT (Single Blade & Twin Blade Models):** Check mower drive belt for tension. Adjust as required. See "MOWER DRIVE BELT ADJUSTMENT", Pages 11 and 12.

CHANGING ENGINE OIL

1. Raise Hood.
2. Disconnect Spark Plug Wire.
3. Fashion an Oil Drain Trough from metal or cardboard as shown in Figure 17.

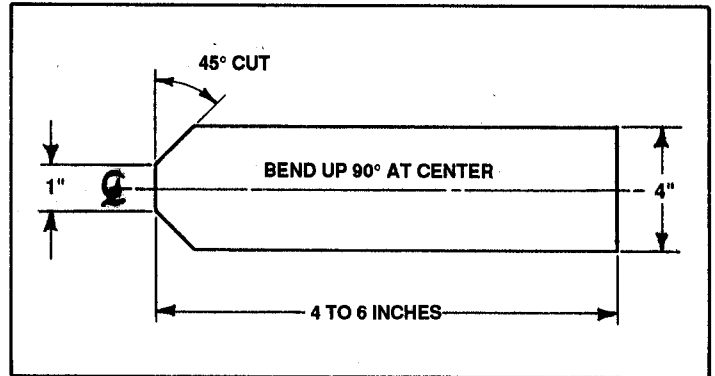

FIGURE 17

4. Put a brick or block of wood under each wheel on opposite side of Oil Drain.
5. Loosen Oil Fill Cap.
6. Loosen Oil Drain Plug. Place trough under plug. Place a flat container (2 qt. Min. Capacity) beneath end of Oil Drain Trough. Remove plug. See Figure 18.
7. Allow engine oil to drain completely.

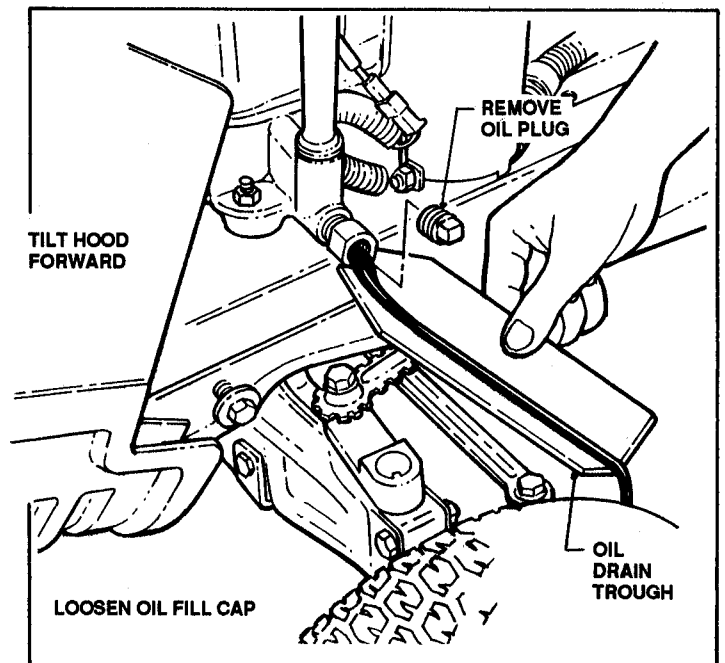

FIGURE 18

8. Reinstall Oil Plug, remove Fill Cap and refill crankcase with oil. Refer to the Engine Owner's Manual for engine oil specifications.

SERVICE

EVERY 25 OPERATING HOURS

- **FRONT WHEEL BEARINGS:** Lubricate Bearings through the fitting on hub of each front wheel. See Figure 19.

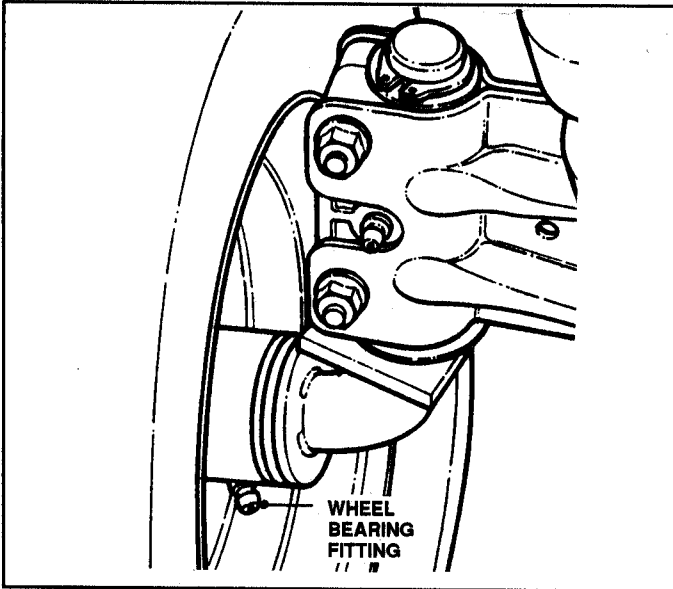

FIGURE 19

- **FRONT AXLE:** Lubricate the Spindle Fitting on each side of the front axle. (R.H. Spindle Fitting faces forward, L.H. Fitting faces to the rear). See Figure 20.

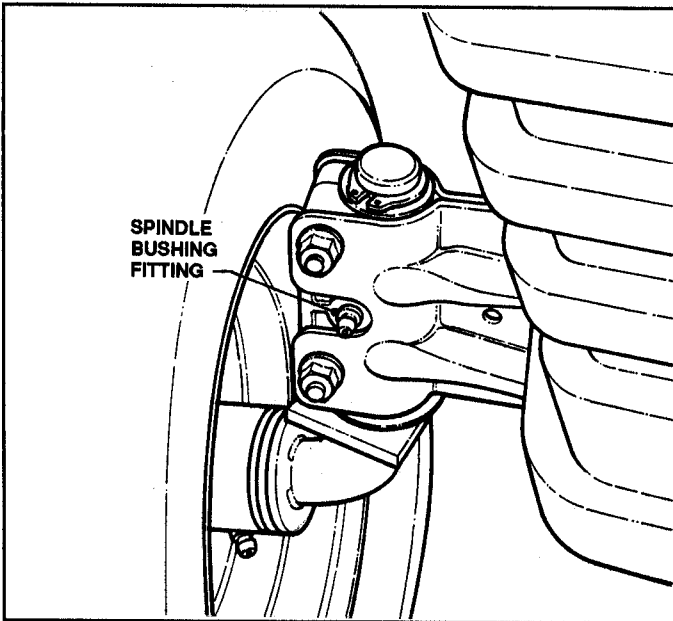

FIGURE 20

- **CLUTCH/BRAKE PIVOT:** Lubricate the Clutch/ Brake Pivot from L.H. underside of tractor. See Figure 21.

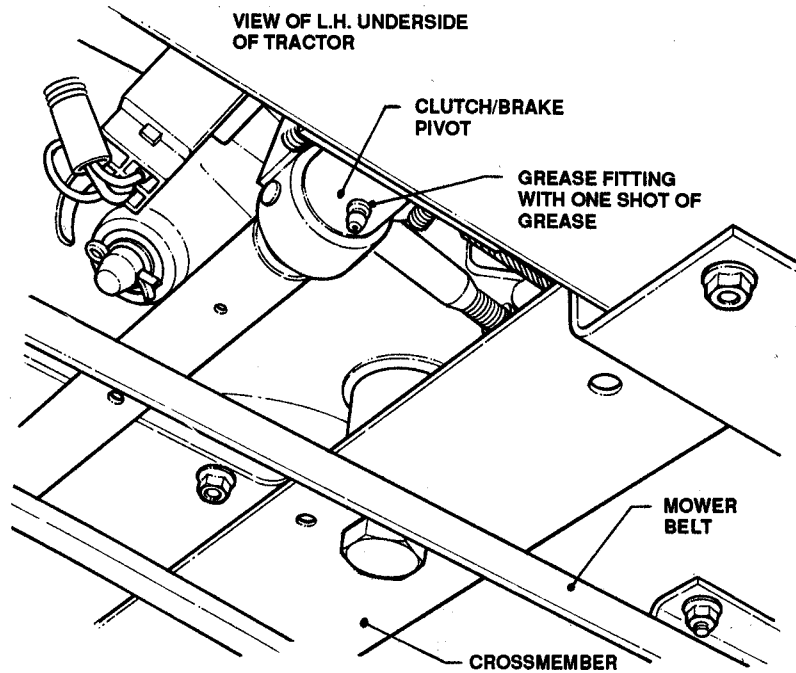

FIGURE 21

- **CHANGE OIL IN ENGINE CRANKCASE** with oil of weight and grade specified in Engine Owner's Manual.
- **ENGINE AIR CLEANER:** Refer to Engine Owner's Manual for details.
- **STEERING SECTOR GEAR:** Coat Gear lightly with 30 Wt. Motor Oil.
- **STEERING SHAFT:** Lightly coat the wear points of the Steering Shaft with 30 Wt. Motor Oil.
- **ALL LINKAGE & PIVOT POINTS:** Coat lightly with 30 Wt. Motor Oil.
- **MOWER DECK BELT:** Check adjustment of Mower Deck Belt. Adjust as required.
- **MOWER DECK LEVEL:** Check level of Deck. Adjust if needed.
- **MOWER BLADE(S):** Check Mower Blade(s) for tightness, sharpness and condition. Tighten or sharpen if needed - replace as required.



WARNING!



Disconnect Spark Plug Wire Before Inspecting/Checking Mower Blade(s). Wear Gloves or Use Suitable Protection When Handling Blade(s).

- **CLEAN UNDERSIDE OF MOWER DECK:** Remove Ignition Key, disconnect Spark Plug Wire, then use putty knife or scraper to remove any accumulation of cut grass from under Deck. Rinse with hose pipe.

SERVICE

END OF EACH SEASON (OR EVERY 100 HOURS)

- PERFORM ALL SERVICE REQUIREMENTS previously detailed in "EVERY 25 OPERATING HOURS" of Maintenance and Lubrication Schedule.
- SERVICE ENGINE AIR CLEANER and SPARK PLUG.
- SERVICE FUEL FILTER as instructed below.

FUEL SYSTEM SERVICE

(Kohler Engines)

Check the In-Line Fuel Filter at frequent intervals and replace before the screen becomes clogged with sediment. Make sure the replacement is correctly installed with the arrow on filter pointing toward the engine. Check the Fuel System Components frequently and replace any parts showing worn spots or cracks. See Figure 22.

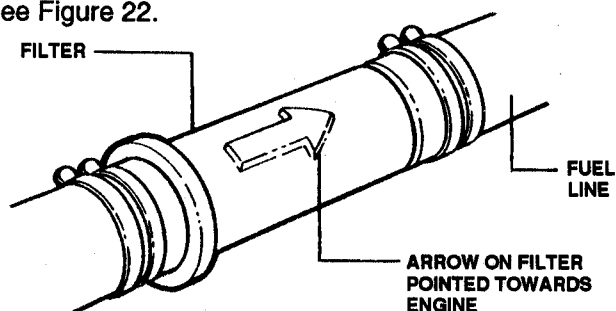

FIGURE 22

(Briggs & Stratton Engines)

The In-Line Fuel Filter furnished with Briggs & Stratton engines is shown below. Make sure the replacement filter is correctly installed with "IN" marking toward the fuel tank and "OUT" toward the engine. Replace any parts which appear worn. See Figure 23.

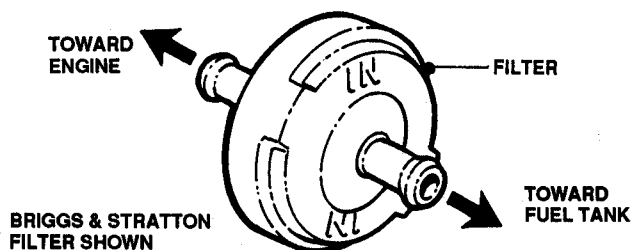

FIGURE 23

BATTERY SERVICE

Check the battery once each month. The battery is located underneath the Operator's seat. Unscrew the two seat adjusting knobs until the seat assembly can be lifted up and moved to one side for access to the battery (do not disconnect the seat switch wire). Remove the two cell covers and add distilled water as necessary to bring the level of the electrolyte up to about 3/32" over the plates in each cell. DO NOT FILL TO THE RINGS. Carefully reinstall covers. In freezing weather, charge the battery after adding water to thoroughly mix the water in the electrolyte. Keep the terminals and cables clean and tight and make sure the

Red Boot (shown in Figure 20) remains in position over the Positive (+) Terminal. Always disconnect negative (-) Terminal first and reconnect last. See Figure 24.

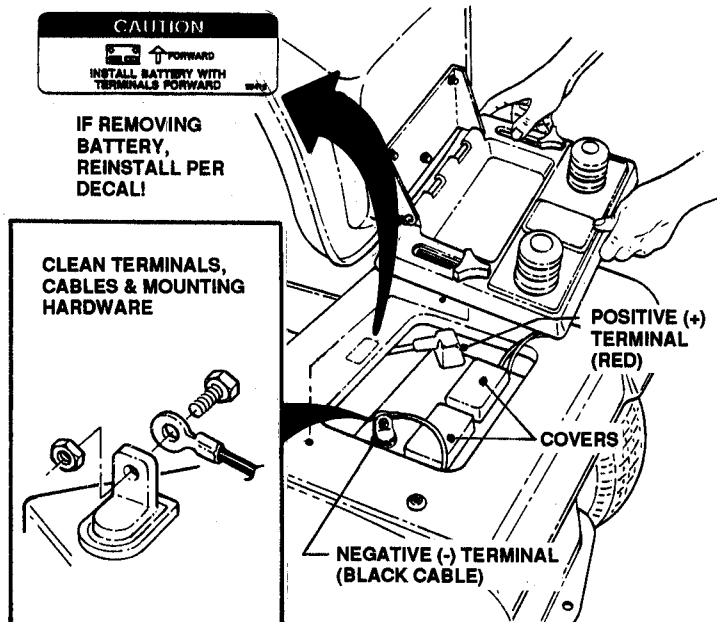

FIGURE 24

BATTERY CHARGING

The engine is equipped with a Flywheel Alternator to charge the Battery. If the tractor is not run regularly, connect the Battery to a charger monthly to maintain the specific gravity at 1.250 or higher. If this reading falls below 1.175, the Battery liquid may freeze when temperatures drop to around zero degrees F. To charge, connect per instructions furnished with charger. If time allows, slow charge at 1 amp for ten hours or as an alternate, fast charge at 3 amps for four hours. Observe all precautions while charging.

ADJUSTING TIRE PRESSURE

Check Tire Pressure at frequent intervals. A low tire on one side causes uneven mowing. Pressure in front tires should be maintained at 12 psi while rear tire pressure should be 10 psi.

MOWER DRIVE BELT ADJUSTMENT (SINGLE BLADE DECK)

Normally, within the first few hours of operation, the MOWER DRIVE BELT will seat into the pulleys and become slack. To regain correct Belt tension, follow Steps 1 thru 7.

1. Remove Ignition Key.
2. Disconnect Spark Plug Wire.
3. Lower MOWER DECK to lowest position.
4. Push BLADE CONTROL LEVER downward to "OFF" position.
5. Remove nut and bolt from Linkage Rod. Locate Rod one hole further back on Link Bracket and reinstall nut and bolt. See Figure 25.

SERVICE

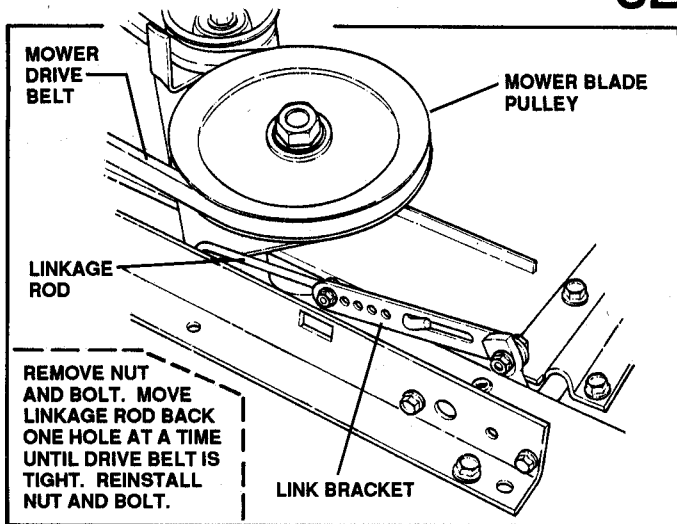

FIGURE 25

6. Pull BLADE CONTROL LEVER up to "ON" position, then check Belt tension.
7. If Belt is still too slack, move nut and bolt to another hole until tension is correct.

MOWER DRIVE BELT ADJUSTMENT

(TWIN BLADE DECK)

Normally, within the first few hours of operation, the MOWER DRIVE BELT will seat into the pulleys and become slack. To regain correct Belt tension, follow Steps 1 thru 5.

1. Lower MOWER DECK to lowest position.
2. Push BLADE CONTROL LEVER downward to "OFF" position.
3. Remove BLADE CABLE SPRING from hole in BRAKE ARM. Reattach Spring in next hole forward. See Figure 26.

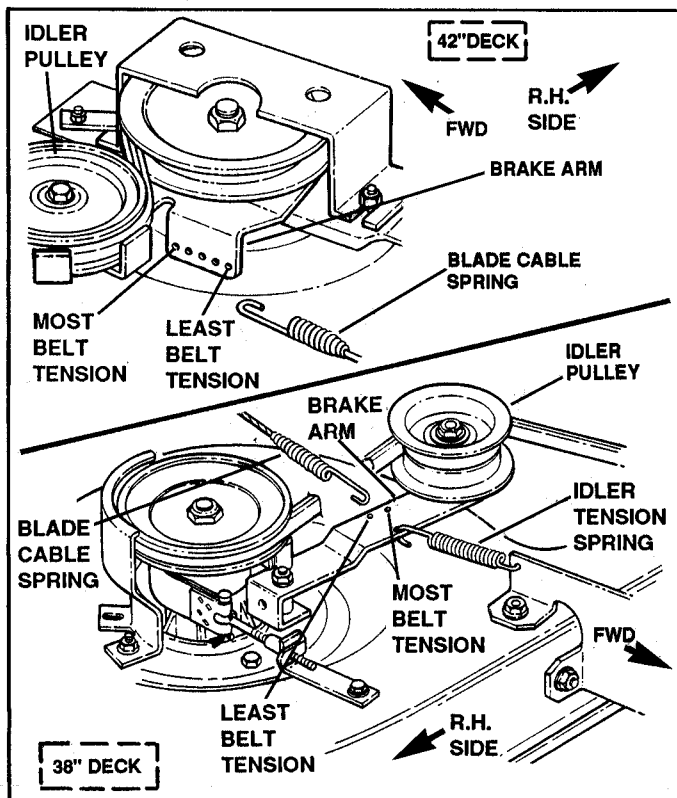

FIGURE 26

4. Pull BLADE CONTROL LEVER up to "ON" position, then check Belt tension.
5. If Belt is still too slack, move Spring to another hole until tension is correct.

MOWER SERVICE & ADJUSTMENTS

Keep the topside of the mower free of grass cuttings. Buildup of clippings could cause belt problems and also might present potential fire hazard, especially when dry. If uneven cutting is noted, check the tire pressure first as this is the most common cause. If tire pressure is correct and uneven cutting persists, move the tractor to a flat, level surface, such as a garage floor, and check the deck level. (See "LEVELING MOWER", Pages 14 & 15). To prolong the life and efficiency of your mower, keep the underside of deck clean and free of accumulated grass clippings by washing it down with a hose and/or scraping with a wire brush and scraper. Make sure this is done at the end of the cutting season before placing the Mower in storage.

BLADE BRAKE ADJUSTMENT

(SINGLE BLADE DECK)

The BLADE BRAKE ASSEMBLY is designed to stop Blade rotation within 3 seconds after the BLADE CONTROL LEVER has been pushed downward to "OFF". Should the Blades not stop within 3 seconds, the BLADE BRAKE must be adjusted as follows:

1. Lower Deck to lowest position.
2. Push BLADE CONTROL LEVER downward to "OFF" position.
3. Inspect BRAKE BAND closely in order to determine approximate amount of adjustment required.
4. Tighten BRAKE BAND by loosening jam nut and turning T-nut, on end of eyebolt, clockwise 1 to 2 turns, or until BRAKE BAND tightens. Make sure flanged lip on T-nut is positioned vertically to fit into slotted hole in Deck Rail. See Figure 27.

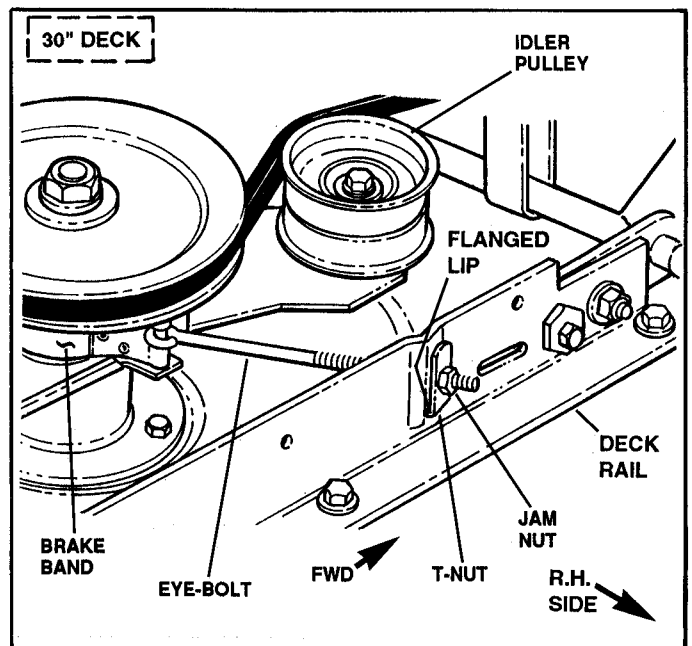

FIGURE 27

SERVICE

BLADE BRAKE ADJUSTMENT

(TWIN BLADE DECKS)

The BLADE BRAKE assembly is designed to stop blade rotation within 3 seconds after the BLADE CONTROL LEVER has been pushed downward to "OFF". Should the blades not stop within 3 seconds, the BLADE BRAKE must be adjusted as follows:

1. Lower deck to lowest position.
2. Push BLADE CONTROL LEVER downward to "OFF" position.
3. (42" DECKS ONLY!) Loosen retaining nut on R.H. OUTSIDE PULLEY BELT COVER and swing cover out of way. See Figure 28.

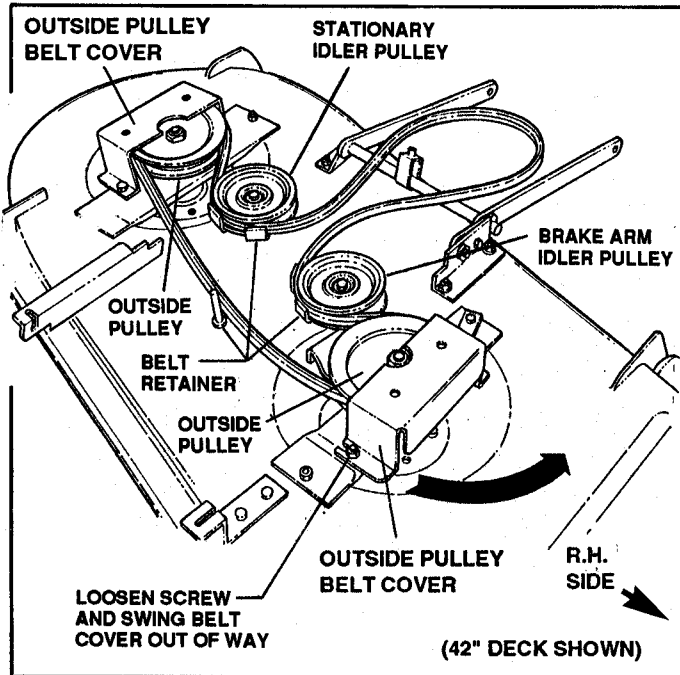

FIGURE 28

4. Inspect BRAKE BAND closely in order to determine approximate amount of adjustment required.
5. Tighten BRAKE BAND by loosening jam nut and turning T-nut, on end of eyebolt, clockwise 1 to 2 turns, or until brake band tightens. Make sure flanged lip on T-nut is positioned to fit over edge of anchor. See Figure 29.

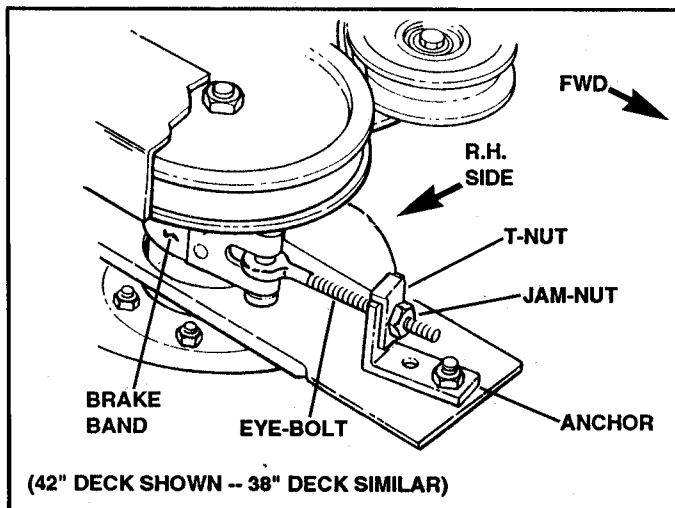

FIGURE 29

6. After adjusting BLADE BRAKE, start mower, engage blades, then disengage blades to check stopping time. Readjust if necessary.

CUTTING BLADE SERVICE

Check at frequent intervals to make sure the Blade is securely tightened and that it is in good condition.

Replace Blade if badly chipped, bent, out of balance, or as soon as notch starts wearing in the tip between the flat surface and upturned lift as depicted in Figure 30. This type wear pattern occurs more rapidly under sandy soil conditions.

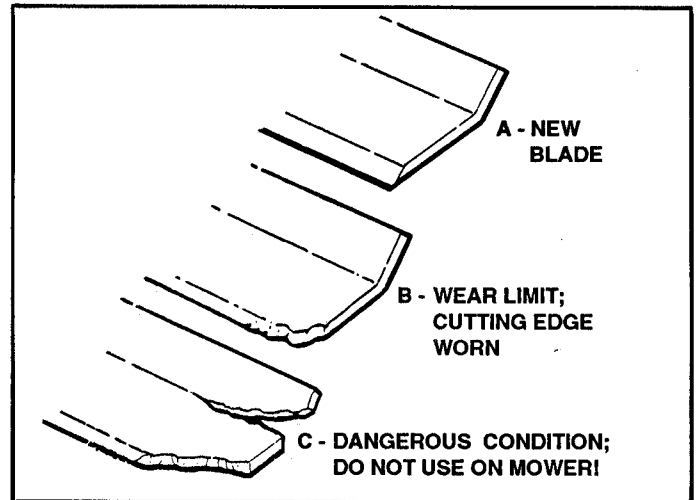

FIGURE 30

⚠ DANGER ⚠

Never operate the mower with blade worn to the extent shown in View C as the tip could fly off, causing personal injury or property damage.

Sharpen Blade when the cutting edges become dull if the blade is in otherwise good condition. When dull, the grass cut ends will be ragged and usually turn brown soon after mowing. For best results, remove the blade and sharpen it on a grinding wheel at an angle of 22 to 28 degrees. The cutting surface should extend in about 2 1/2" from the tips. Check the blade after sharpening to determine that it is still balanced. It will cause excessive vibration if unbalanced. See Figure 31.

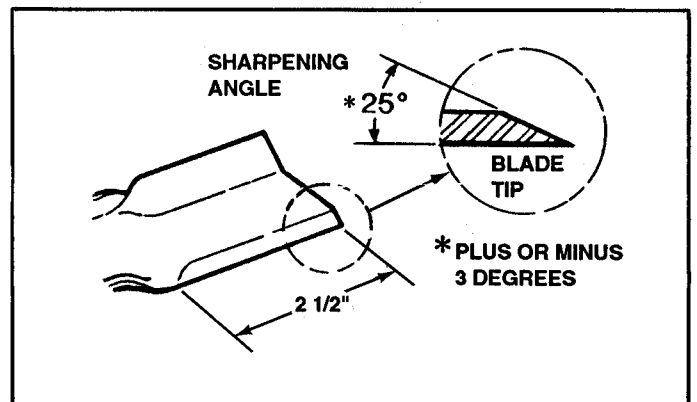

FIGURE 31

SERVICE

CAUTION

Avoid cutting yourself on cutting blade!
Protect your hands from cuts while handling blade.

SINGLE BLADE INSTALLATION

Install sharpened or replacement blade with components in same sequence as removed. Make sure that the flange on each side of blade fits over the edge of the BLADE DRIVE BAR when installing. DO NOT substitute any components here. Tighten the blade retaining capscrews to 70-80 foot pounds torque value. See Figure 32.

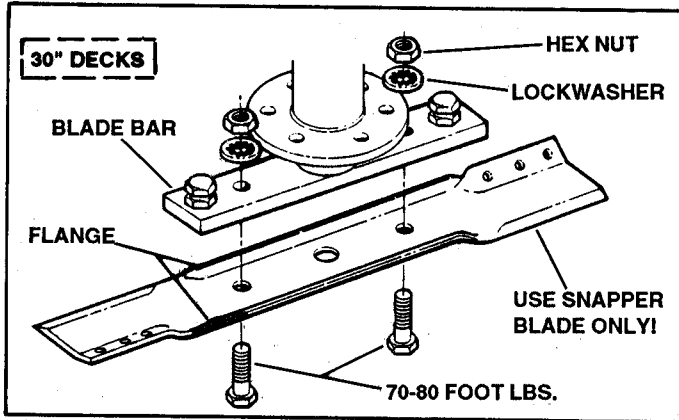

FIGURE 32

TWIN BLADE INSTALLATION

Install sharpened or replacement blades with components in same sequence as removed. Make sure that the bearing retainers and cone washers are installed as shown in Fig. 32A!

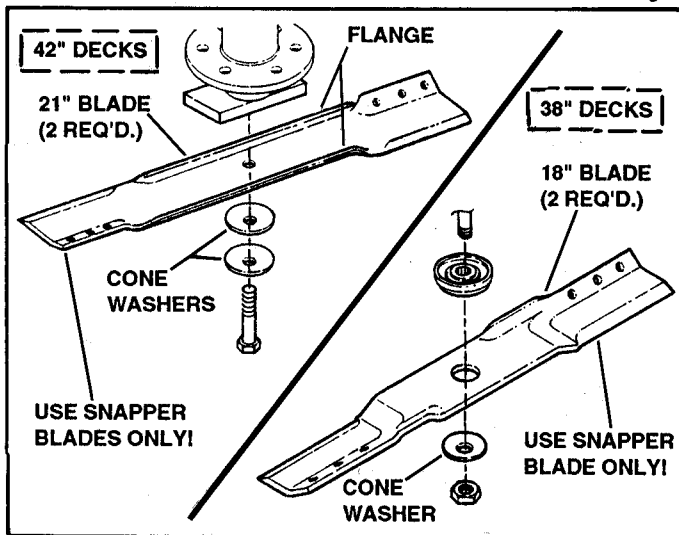

FIGURE 32A

REMOVING & INSTALLING MOWER DECK

The mower deck is attached to the tractor and leveled at the factory. If the mower deck is to be removed for cutting blade service, or to install another attachment, be sure that the mower settings remain unchanged.

TO REMOVE MOWER DECK:

1. Push BLADE CONTROL LEVER downward to "OFF" position.

2. Move mower to level surface.
3. Stop engine.
4. Set PARKING BRAKE.
5. Raise hood and disconnect spark plug wire.

NOTE

Put a small stick (broom handle, etc.) under rear of mower deck before lowering - this will help later in lifting the rear of the deck to disconnect the rear lift arms.

6. Lower deck to lowest position.
7. Disconnect BLADE CONTROL SPRING from mower deck. See Figure 33.

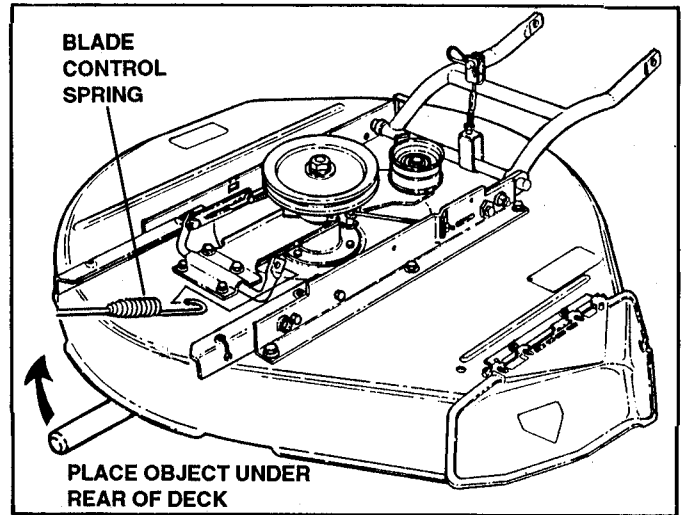

FIGURE 33

8. Using the small stick as a lever, lift up rear of deck and disconnect the rear lift cables. See Figure 34.

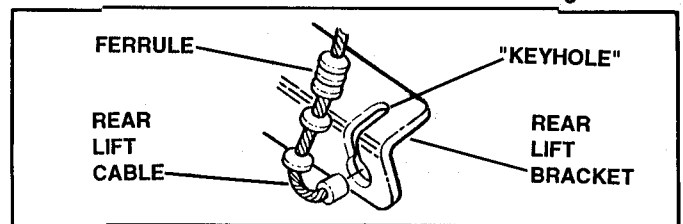

FIGURE 34

NOTE

Make note of how many adjusting ferrules are under each deck hanger bracket before disconnecting cables. Rehang deck the same way.

9. Disconnect DECK LIFT CABLE from front lift arm. See Figure 35.

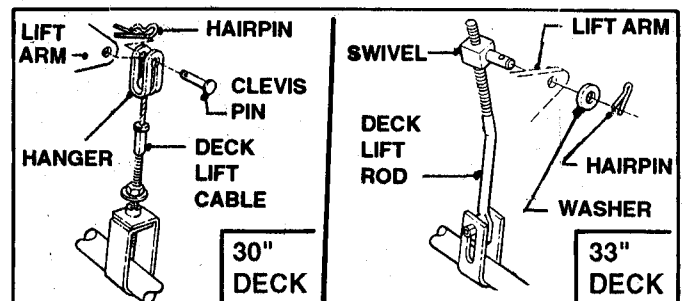

FIGURE 35

SERVICE

- Remove hairpins from front deck hanger rod. See Figure 36.

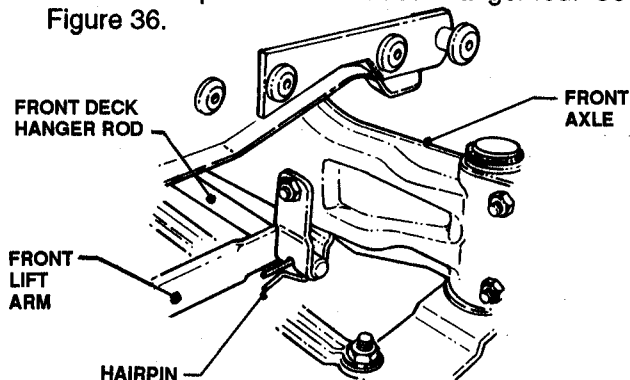

FIGURE 36

- Turn front wheels to the left and remove front hanger rod.



- Push deck forward and remove mower deck belt from engine pulley.
- Remove deck from right side of mower.
- Reinstall deck in reverse order.

WHEEL BRAKE TEST & READJUSTMENT

- Test the wheel braking action at frequent intervals to insure proper stopping in the event of possible emergencies. Normally, the mower should stop from top forward speed within approximately three feet after the CLUTCH/BRAKE PEDAL has been fully depressed.
- To adjust the braking action:
 - Turn the brake adjusting screw one-half turn to the right (clockwise) to tighten brake or to the left (counterclockwise) to loosen. See Figure 37.

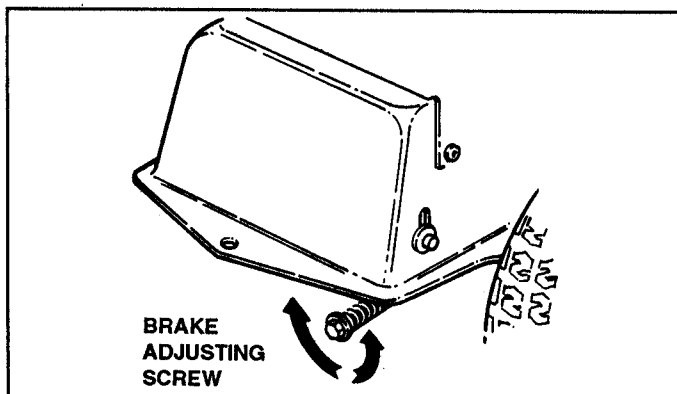

FIGURE 37

- Continue to adjust screw one-half turn at a time until braking action is satisfactory.

HOOD REMOVAL (All Models)

- Tilt hood forward.
- Remove hood cable clip from engine. See Figure 38.

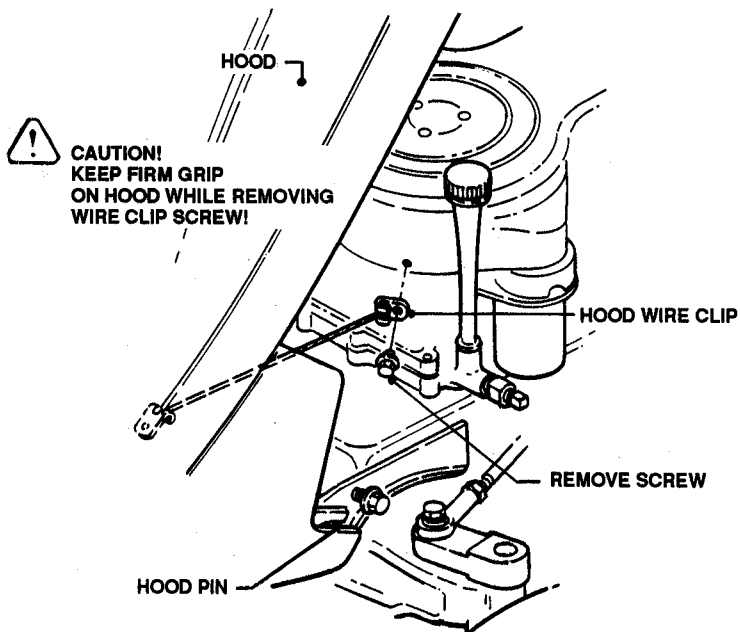

FIGURE 38

- Lift hood off pins.
- Reinstall hood in reverse order.

ADJUSTING STEERING

If steering develops excessive free-play, then the ECCENTRIC STEERING BOLT must be adjusted. Proceed as follows:

- Working from the left side of the tractor, use a 7/16" wrench to loosen nut on top of carriage bolt. See Figure 39.
- Push eccentric clockwise (towards R.H. side of tractor) until free-play in steering wheel is minimized.
- Retighten nut.

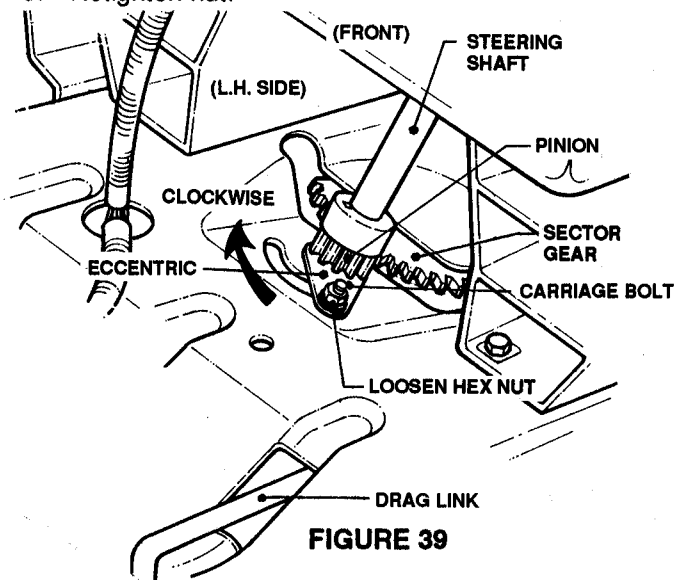

FIGURE 39

SERVICE (Continued)

NOTE: The following pages 16 thru 17 are for removing and installing mower as well as leveling mower deck for LT140G38AKV Model Lawn Tractors with the 38" Ground Following deck only.

REMOVING & INSTALLING MOWER

The mower is attached to the tractor and leveled at the factory. If the mower is to be removed for cutting blade service, or to install another attachment, be sure that the mower settings remain unchanged.

TO REMOVE MOWER:

1. Lower to lowest position.
2. Remove hairpin from end of torsion rod as shown in Figure 40. Slide deck towards L.H. side until torsion rod is free of deck.

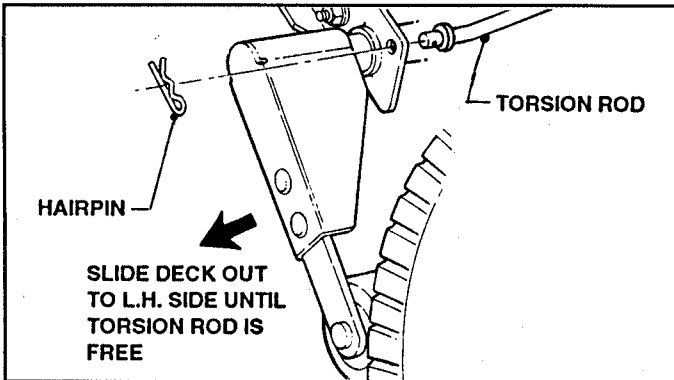

FIGURE 40

3. Remove hairpins and clevis pins from FRONT LIFT ARMS. See Figure 41.

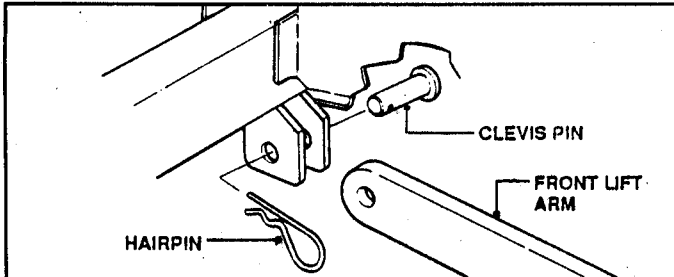

FIGURE 41

4. Push BLADE CONTROL LEVER "DOWN" to "OFF" position.
5. Roll mower deck towards the rear then disconnect the BLADE CABLE SPRING as shown in Figure 42.

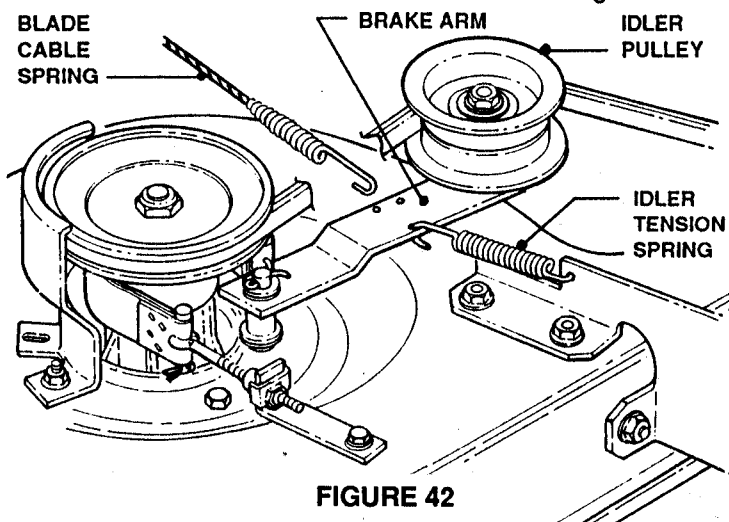

FIGURE 42

6. After deck has been disconnected, turn tractor's front wheels to the left and slide the mower out from the right side. Reverse steps 1 thru 6 to reinstall mower.

NOTE

It may be necessary to move the DECK LIFT LEVER to different positions in order for the mower deck to be removed from underneath tractor.

LEVELING MOWER

With the blades sharpened and properly aligned, a level mower deck will insure a clean, even cut. The mower should be checked for levelness as follows:

1. Check the air pressure in the tires and correct pressure as needed (12 psi front and 10 psi rear tires).
2. Move the tractor to a smooth, flat and level area such as garage floor.
3. Push the LIFT LEVER forward and lower the deck to its lowest position.
4. Turn keyswitch to "STOP" and disconnect spark plug wire from plug.
5. Check the clearance underneath each side of the deck to the floor. If these two dimensions differ more than 1/8", then the deck should be leveled from side to side as follows:

NOTICE!

As shown in Figure 43, the basic mower deck is formed in such a manner that the FRONT lip of the deck is always 1/2" higher off the ground than the REAR lip of the deck when the deck is resting flat on the ground. This fact should be remembered when following the instructions for adjusting the mower deck from front to rear and from side to side.

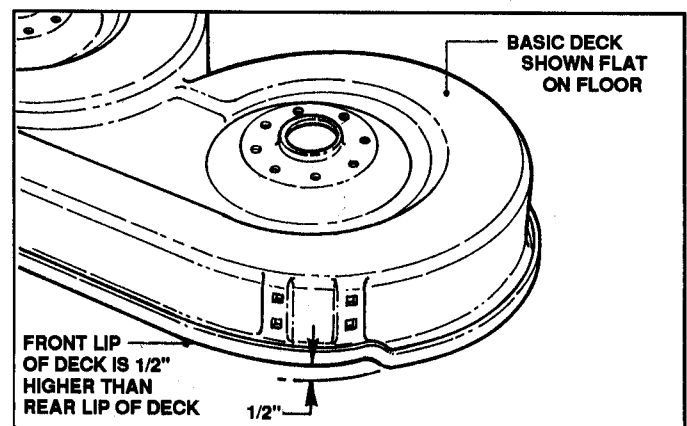

FIGURE 43

LEVELING DECK SIDE TO SIDE

- A. Making sure that mower deck is in its lowest position, loosen the flange nut shown in Figure 43A.

SERVICE (Continued)

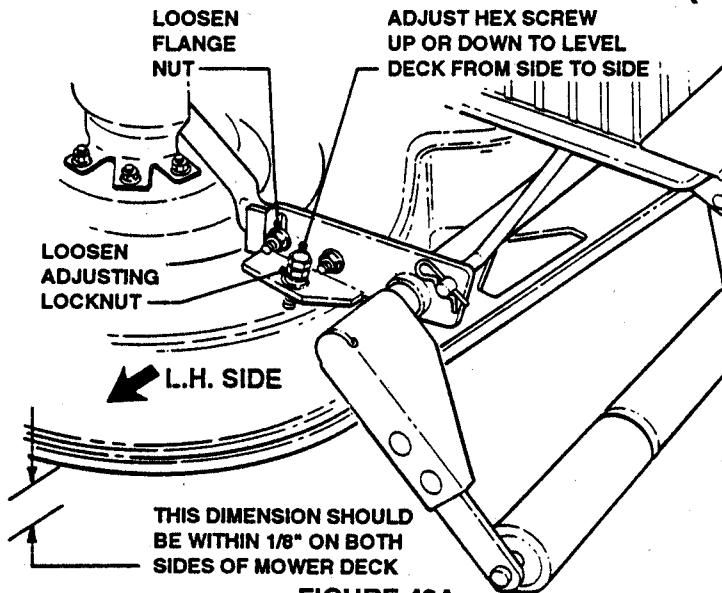

FIGURE 43A

- B. Loosen the adjusting lock nut and turn the adjusting hex screw to level the deck. Check the dimensions on each side of the deck and adjust the screw up or down until the deck is level.
 - C. After deck is level, tighten adjusting lock nut and flange nut.
6. To cut properly, the front of the mower should be adjusted 1/2" higher than the rear. (REMEMBER, the FRONT LIP of the deck is already 1/2" higher than the REAR LIP of the deck! Take this into account when measuring the deck level). Check the clearance underneath the center rear of the deck to the floor. Take this dimension and add 1" for the required height of the front deck to the floor. Make adjustments as follows:

LEVELING DECK FRONT TO REAR

- A. Looking at the mower deck from under the front of tractor, the front-to-rear adjusting nut can be seen as shown in Figure 44.

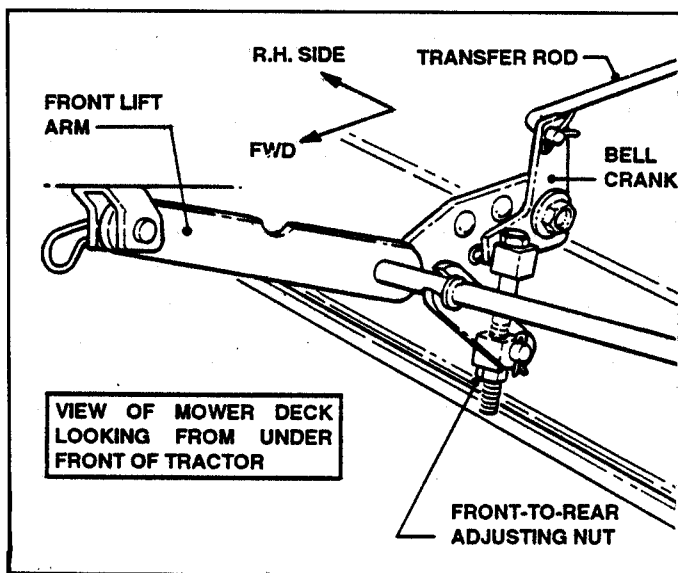

FIGURE 44

- B. After measuring dimensions under front and rear of mower deck, turn the front-to-rear adjusting nut until the front of the deck is 1/2" higher than the rear. See Figure 45.
- C. Make sure that the distance from the floor to each blade tip is within 1/8" of each other at the rear (Blades should be lower at the rear). See Page 19, Figure 48 for blade level.

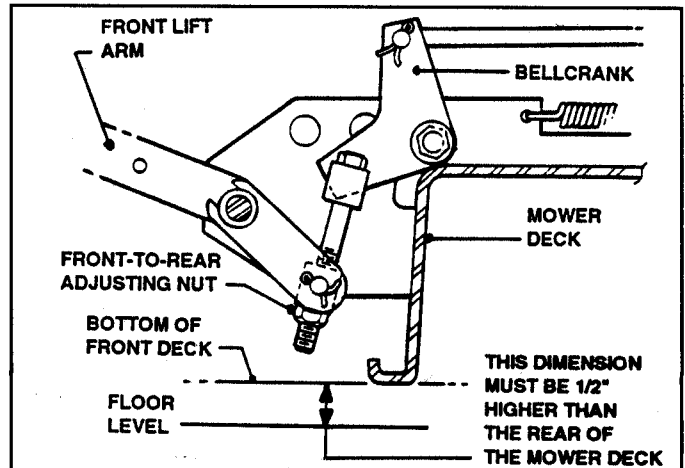

FIGURE 45

ADJUSTING SHIFT DETENT

The mower deck has 5 cutting positions and will cut grass from 1" to 3". Position No. 1 should mow the grass 1" high, while Position No. 5 should mow at 3" high - Positions 2 thru 4 are intermediate heights. When the lift lever is in position 5, check the cutting height from the rear of the blades to the ground. If height of cut is not accurate with "Cutting Height Decal" on lift detent, adjust detent as follows.

1. Lower mower to lowest position.
2. Measure distance from blades to floor level (This dimension should be one inch (1") after deck has been properly leveled).
3. If dimension from blades to floor is not one inch (1"), then loosen the two nuts on the shift detent as shown in Figure 46.

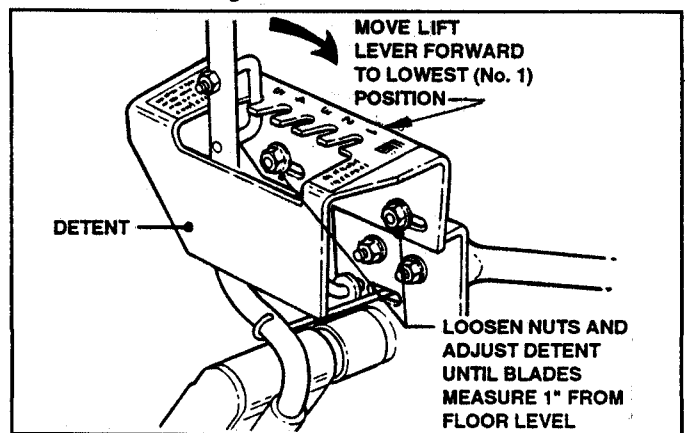

FIGURE 46

4. Adjust shift detent forward or backward until dimension from blades to floor level is one inch (1").
5. Tighten nuts securely.

SERVICE

LEVELING MOWER (Single Blade Deck)

With the blade sharpened and properly aligned, a level mower deck will insure a clean, even cut. The mower should be checked for levelness as follows:

1. Check the air pressure in the tires and correct pressure as needed (12 psi front and 10 psi rear tires).
2. Move the tractor to a smooth, flat and level area such as garage floor.
3. Lock the CLUTCH/BRAKE PEDAL, and shut off the engine. Then move the lift lever to the #3 notch.

A. SIDE TO SIDE LEVEL ADJUSTMENT

1. Place a piece of angle iron under lip at center rear of deck. See Figure 36.
2. Remove the LIFT CABLES from the REAR LIFT ARMS.
3. Measure distance between deck lip (at center of left side) and the floor surface. Compare the distance from right side deck lip to the floor.

NOTE

A deck is considered level if measurements are within 1/8" from side-to-side.

4. If required, adjust side-to-side level of mower deck by loosening the nut on the PIVOT BOLT and the SHOULDER SCREW inside the ECCENTRIC BOLT. See inset, Figure 47.
5. Turn the ECCENTRIC BOLT "UP" or "DOWN" to level deck within 1/8" side-to-side.
6. When deck is level, tighten SHOULDER SCREW and PIVOT BOLT nut.
7. Reattach LIFT CABLES to REAR LIFT ARMS.
8. If either LIFT CABLE is slack, adjust FERRULES until both cables have equal tension. Recheck deck level.

B. FRONT TO REAR LEVEL ADJUSTMENT

1. Measure distance between the floor and the lip at front and rear of the mower deck. Measurements should be the same or 1/8" higher at the rear.
2. Adjust LIFT CABLE FERRULES as required to raise or lower rear of deck. Adjust until deck is properly leveled.

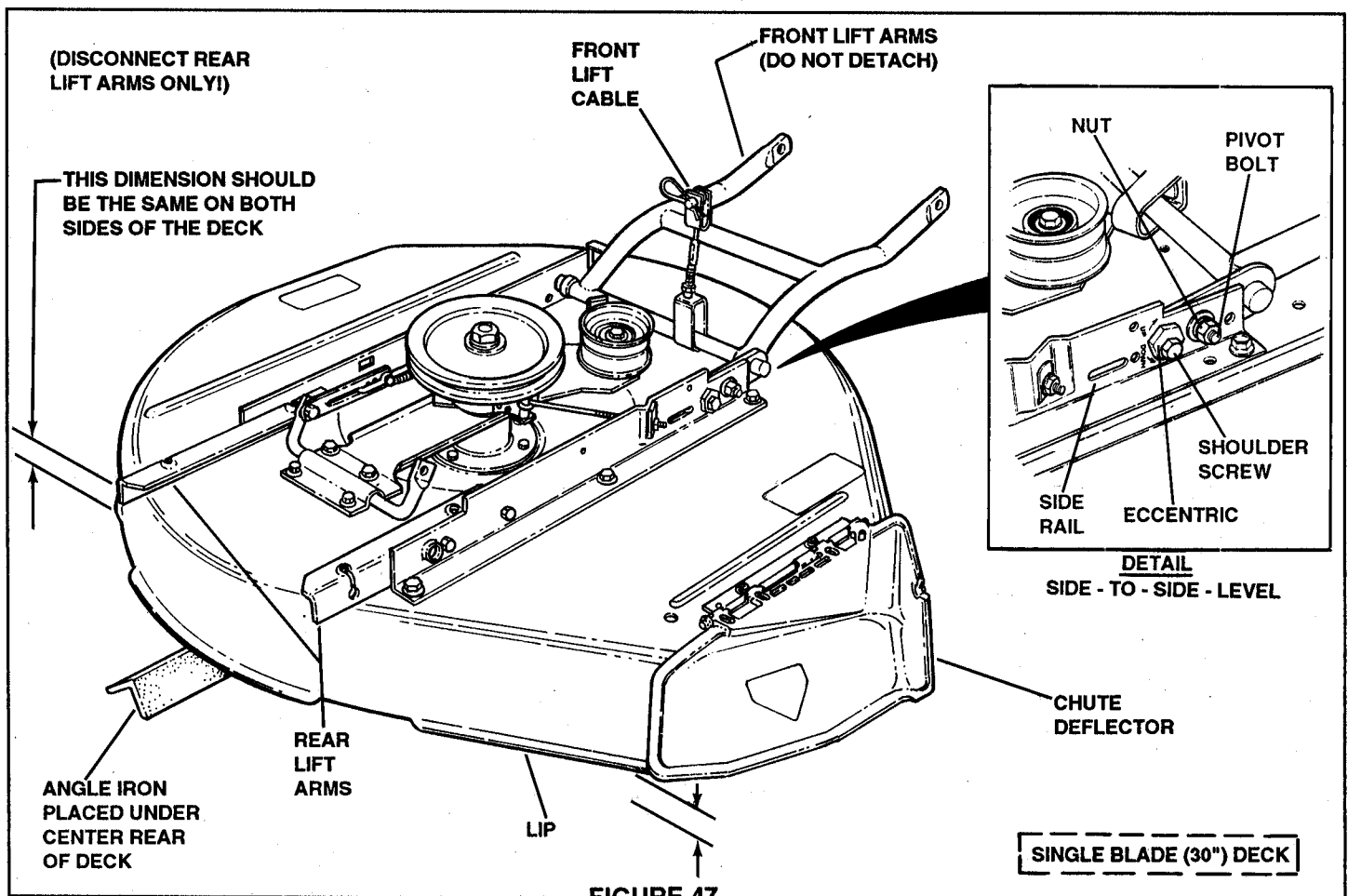

FIGURE 47

SERVICE

LEVELING 38" FRAME HANGING MOWER DECK

(NOTE: Does not include the 38" Ground Following Deck - See pages 16 thru 17)

With the blades sharpened and properly aligned, a level mower deck will insure a clean, even cut. The mower should be checked for levelness as follows:

1. Check the air pressure in the tires and correct pressure as needed (12 psi front and 10 psi rear tires).
2. Move the tractor to a smooth, flat and level area such as garage floor.
3. Move the lift lever to #5 notch.
4. Place a 2 x 4" block on edge under the front lip of the deck in the exact center between the front lift arms. See Figure 48.
5. Disconnect the front lift rod and allow the front lip of the deck to rest on the 2 x 4 block. Adjust the hanger block until the lift rod can be reattached while the deck is still on the block. See Figure 48.
6. Place a 3" high block under the exact center of the rear lip of the deck.
7. Remove the lift cables from the rear lift brackets.
8. Turn both blades perpendicular to tractor frame. The leading blade should have one "tip" near the center of left side deck lip. One "tip" on trailing blade should face the discharge chute. See INSET, Figure 48.
9. Hold eccentric with a large wrench and loosen bolt on outside of front lift arm. Level the deck side to side by turning the eccentric bolt. The distance from the floor to each blade tip should be within 1/8" of each other. See INSET.
10. Place the required number of adjusting ferrules above and below the rear lift arms to level the deck.
11. FRONT TO REAR LEVEL ADJUSTMENT: Level the deck from front to rear until the trailing edges of the blades are level from tip to tip or either 1/8" lower in back than the leading tips of the blades.

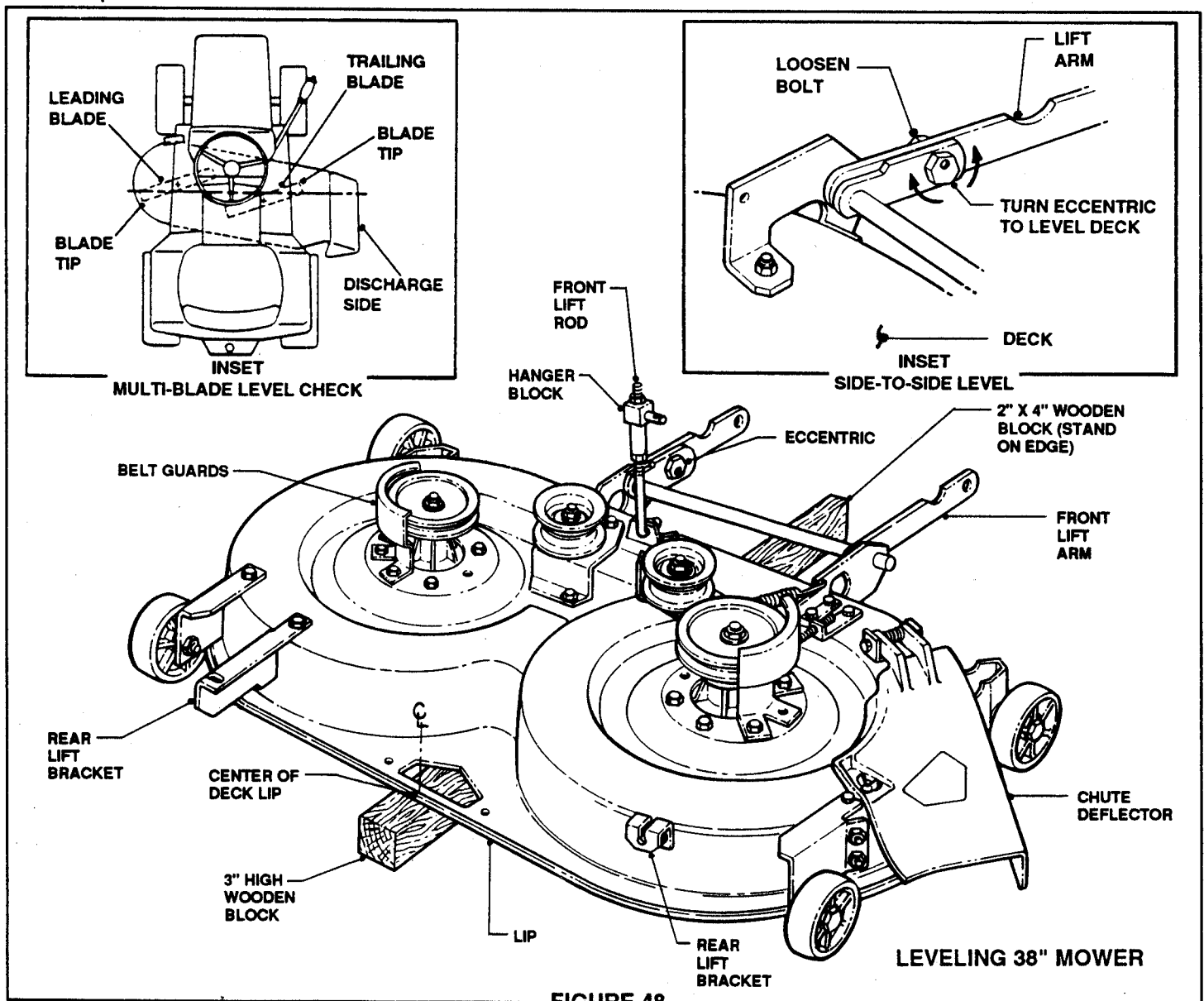

FIGURE 48

SERVICE

LEVELING MOWER (Twin Blade Deck)

With the blades sharpened and properly aligned, a level mower deck will insure a clean, even cut. The mower should be checked for levelness as follows:

1. Check the air pressure in the tires and correct pressure as needed (12 psi front and 10 psi rear tires).
2. Move the tractor to a smooth, flat and level area such as garage floor.
3. Move the lift lever to #5 notch.
4. Place a 2 x 4" block on edge under the front lip of the deck in the exact center between the front lift arms. See Figure 49.
5. Loosen the jam nut on the front lift cable and adjust until the front lip of the deck rests on the 2 x 4 block and the cable is tight. Tighten the cable jam nut and remove the block. See inset, See Figure 49.
6. Place a 3" high block under the exact center of the rear lip of the deck.
7. Remove the lift cables from the rear lift arms.
8. Turn both blades perpendicular to tractor frame. The leading blade should have one "tip" near the center of left side deck lip. One "tip" on trailing blade should face the discharge chute. See lower inset, Figure 37.
9. Loosen nuts on eccentric bolt and pivot bolt and level the deck side to side by turning the eccentric adjusting bolt. The distance from floor to each blade tip should be within 1/8" of each other.
10. Place the required number of adjusting ferrules above and below the rear lift arms to level the deck.
11. **FRONT TO REAR LEVEL ADJUSTMENT:** Level the deck from front to rear until the trailing edges of the blades are level from tip to tip or either 1/8" higher in back than the leading tips of the blades.

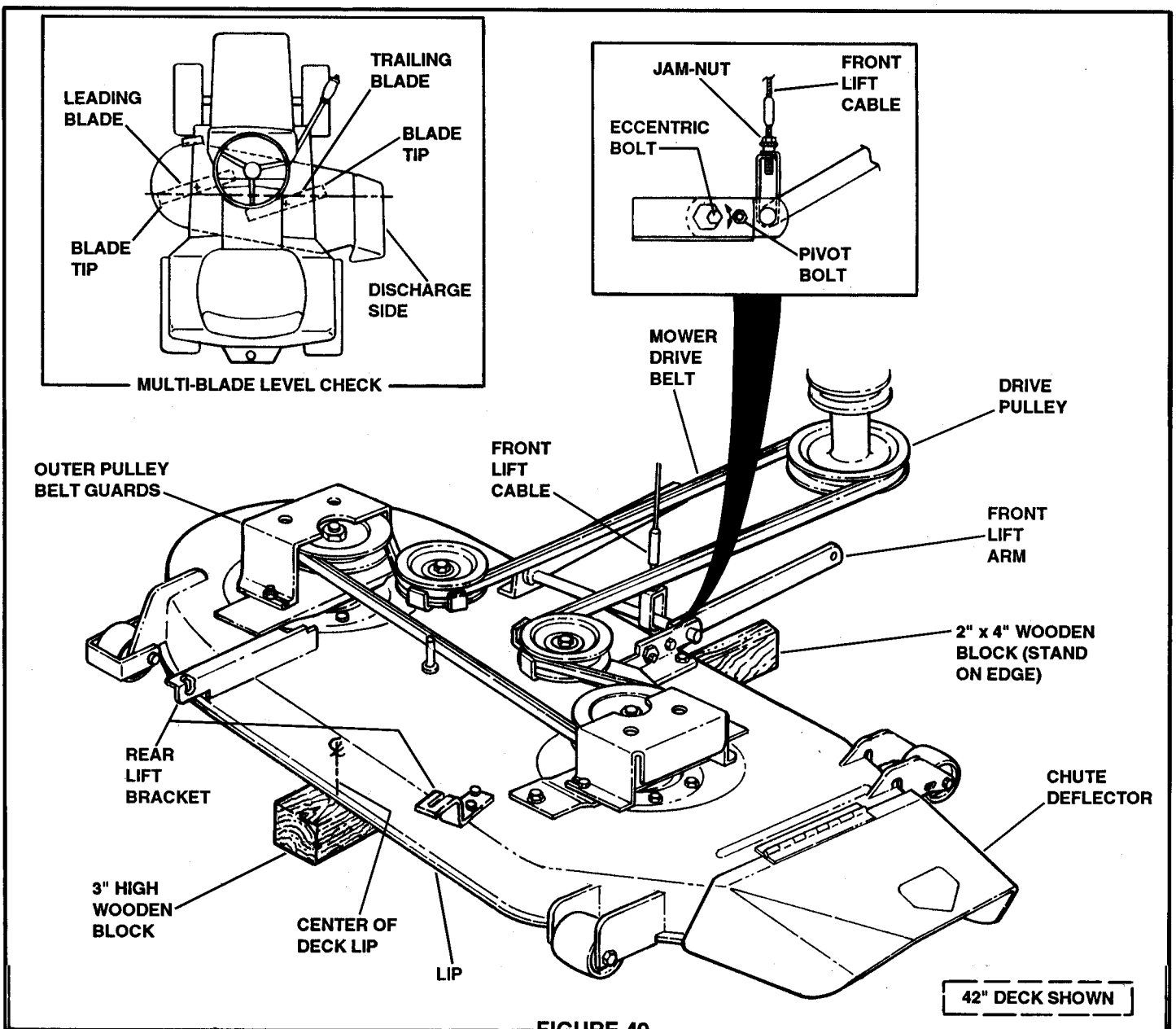

FIGURE 49

SERVICE

TRACTOR DRIVE BELT SERVICE

BELT REMOVAL

1. Raise hood and disconnect spark plug wire.
2. Depress CLUTCH/BRAKE PEDAL and lock into position by pulling PARKING BRAKE LEVER "UP".
3. Remove MOWER DECK.
4. Remove MOWER DECK BELT from bottom pulley of engine. See Figure 50.

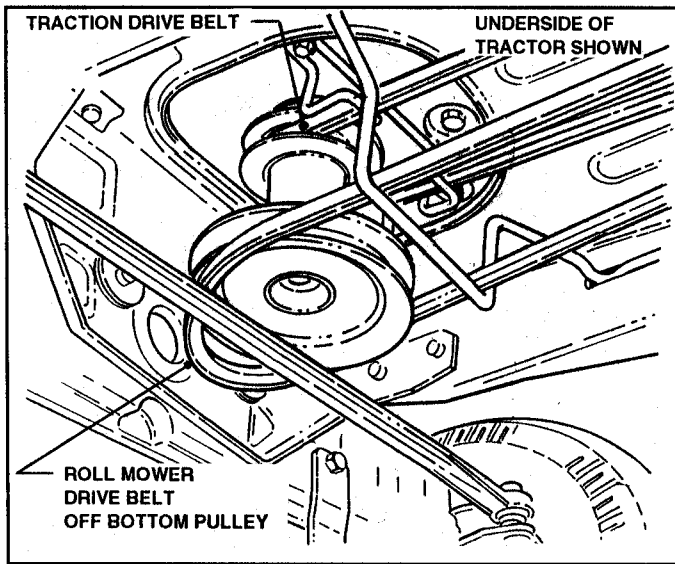

FIGURE 50

NOTE

Although it is possible to remove and replace the drive belt with the mower deck attached, it is recommended that the deck be removed to make belt installation easier.

5. Disconnect idler pulley spring from frame rail. See Figure 51.

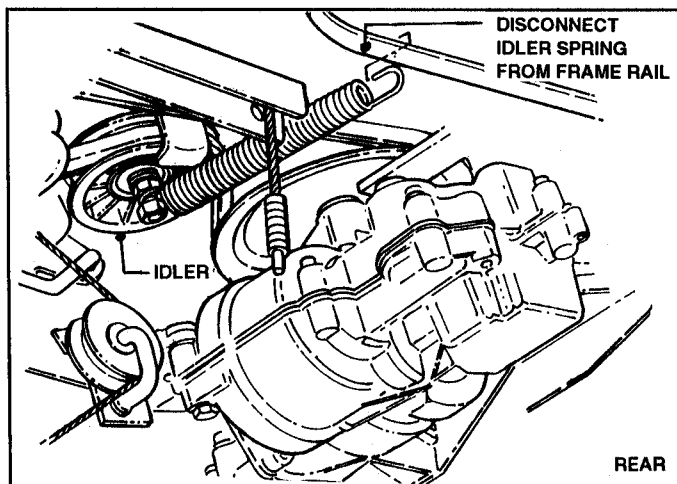

FIGURE 51

6. If necessary, loosen front belt guide and move out of way. See Figure 52.

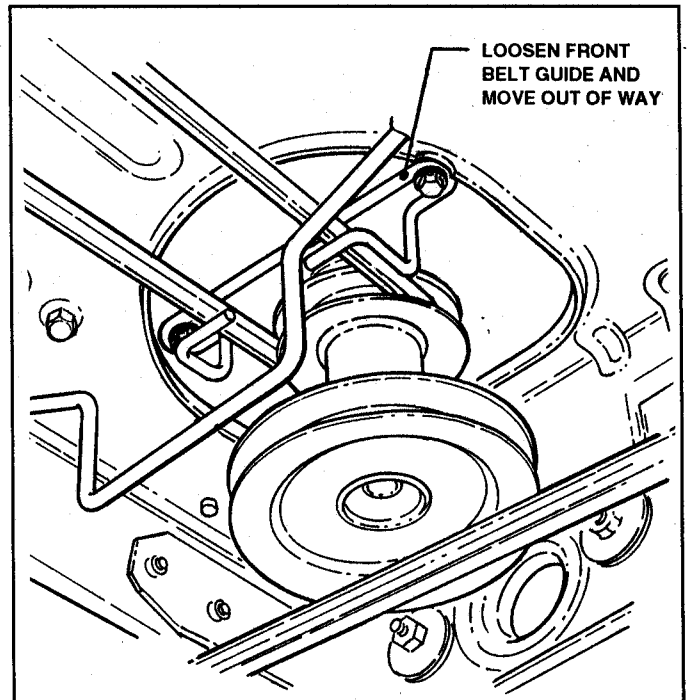

FIGURE 52

7. Remove hairpin from front of CONTROL ROD, then lower CONTROL ROD. See Figure 53.

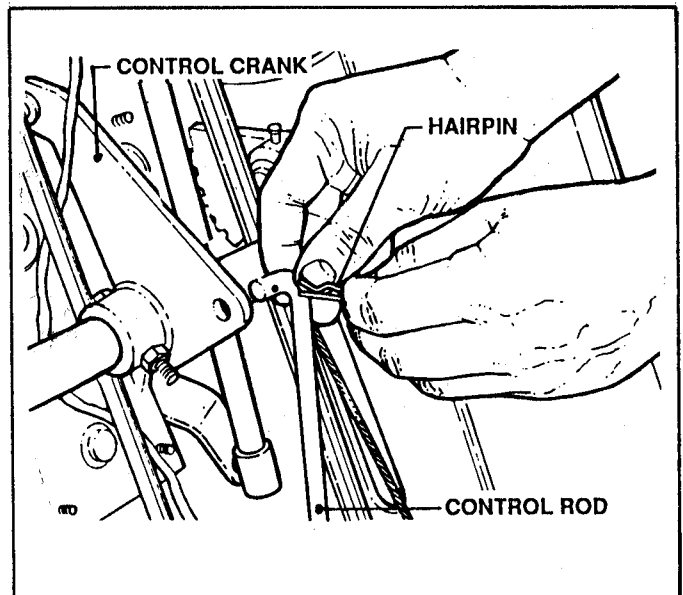

FIGURE 53

8. Remove DRIVE BELT from engine pulley. See Figure 54.

SERVICE

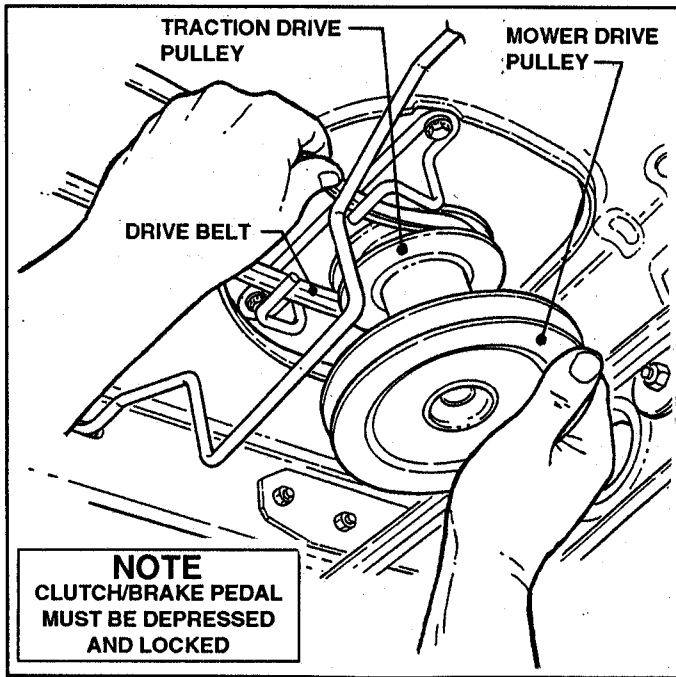

FIGURE 54

9. Loosen retaining nuts on fixed idler and tension idler pulleys and slide belt guides out enough to allow belt removal. See Figure 55.

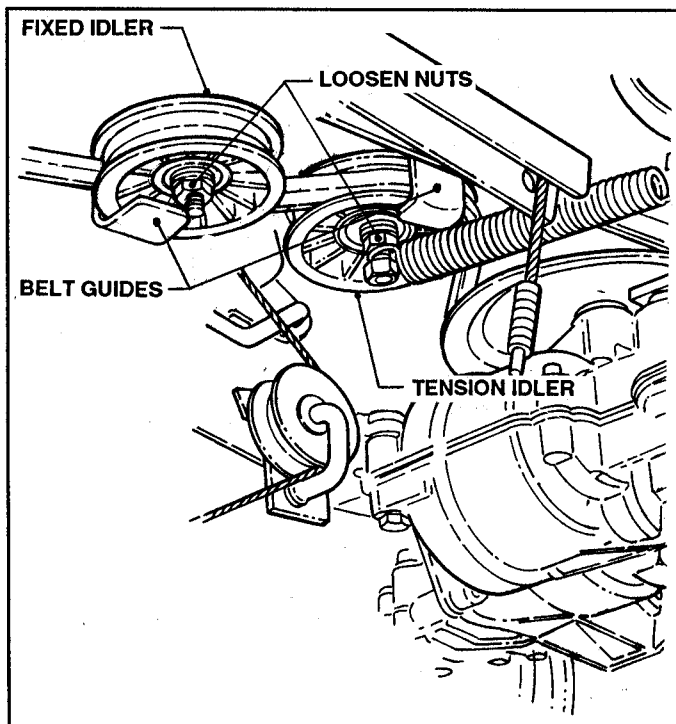

FIGURE 55

10. Working at the rear of the tractor, pull DRIVE BELT back until it can be removed from TRANSAXLE PULLEY.

BELT INSTALLATION

1. Place DRIVE BELT around TRACTION DRIVE PULLEY (top pulley on engine shaft).
2. Place belt over CONTROL CRANK and between rear lift arm and tractor frame. See Figure 56. "DRIVE BELT ROUTING".
3. Route belt around outside of FIXED IDLER PULLEY and inside of TENSION IDLER PULLEY.

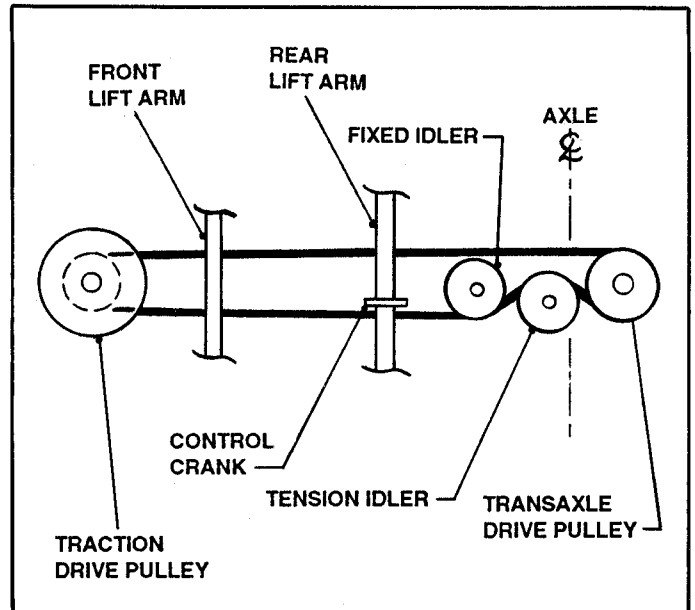
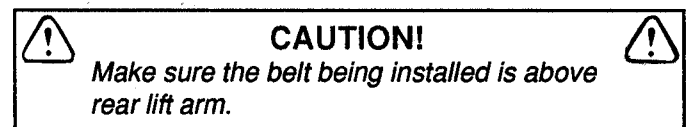

FIGURE 56

4. Place the DRIVE BELT on TRANSAXLE PULLEY.
5. Readjust BELT GUIDES on fixed idler and tension idler pulleys. Tighten retaining nuts.
6. Readjust front belt guide. Tighten bolt.
7. Reinstall the CONTROL ROD on control crank.



8. Reinstall the MOWER DECK (if removed).

ELECTRICAL - Briggs & Stratton without Lights

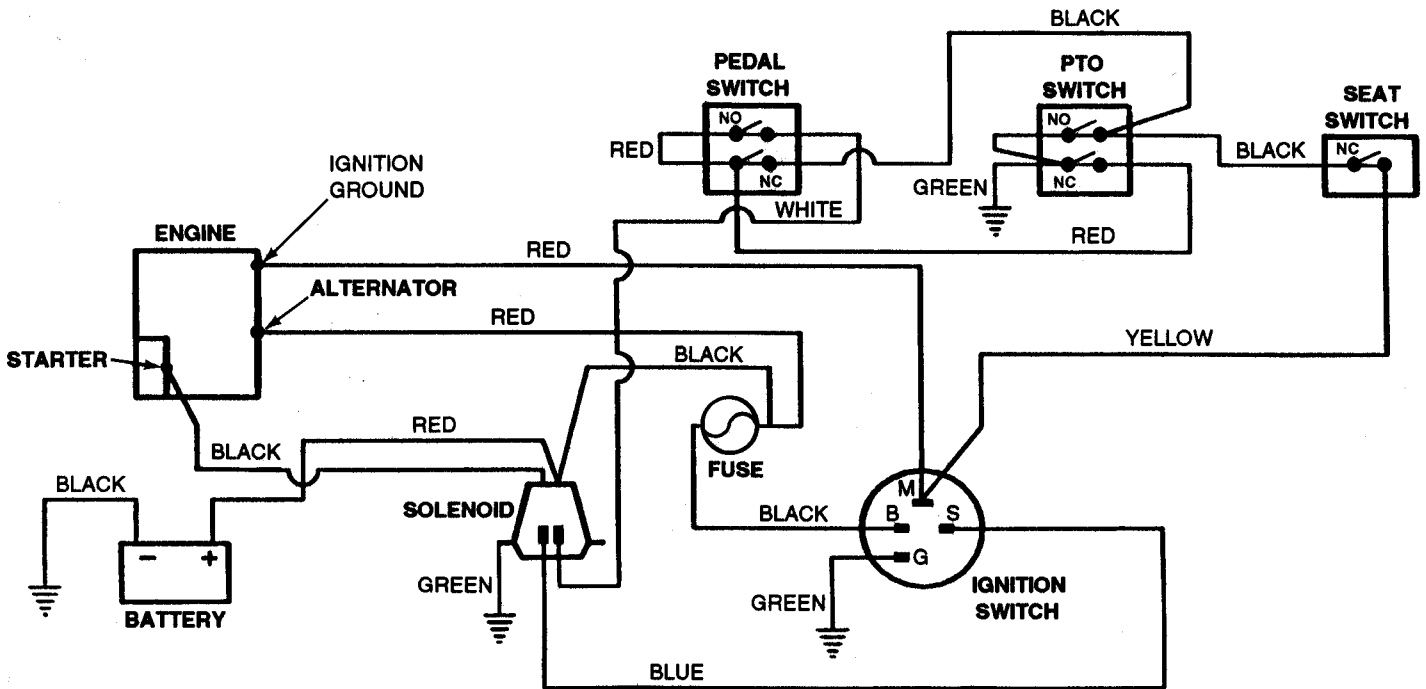

SCHEMATIC

ILLUSTRATED DIAGRAM

P/N 2-4364

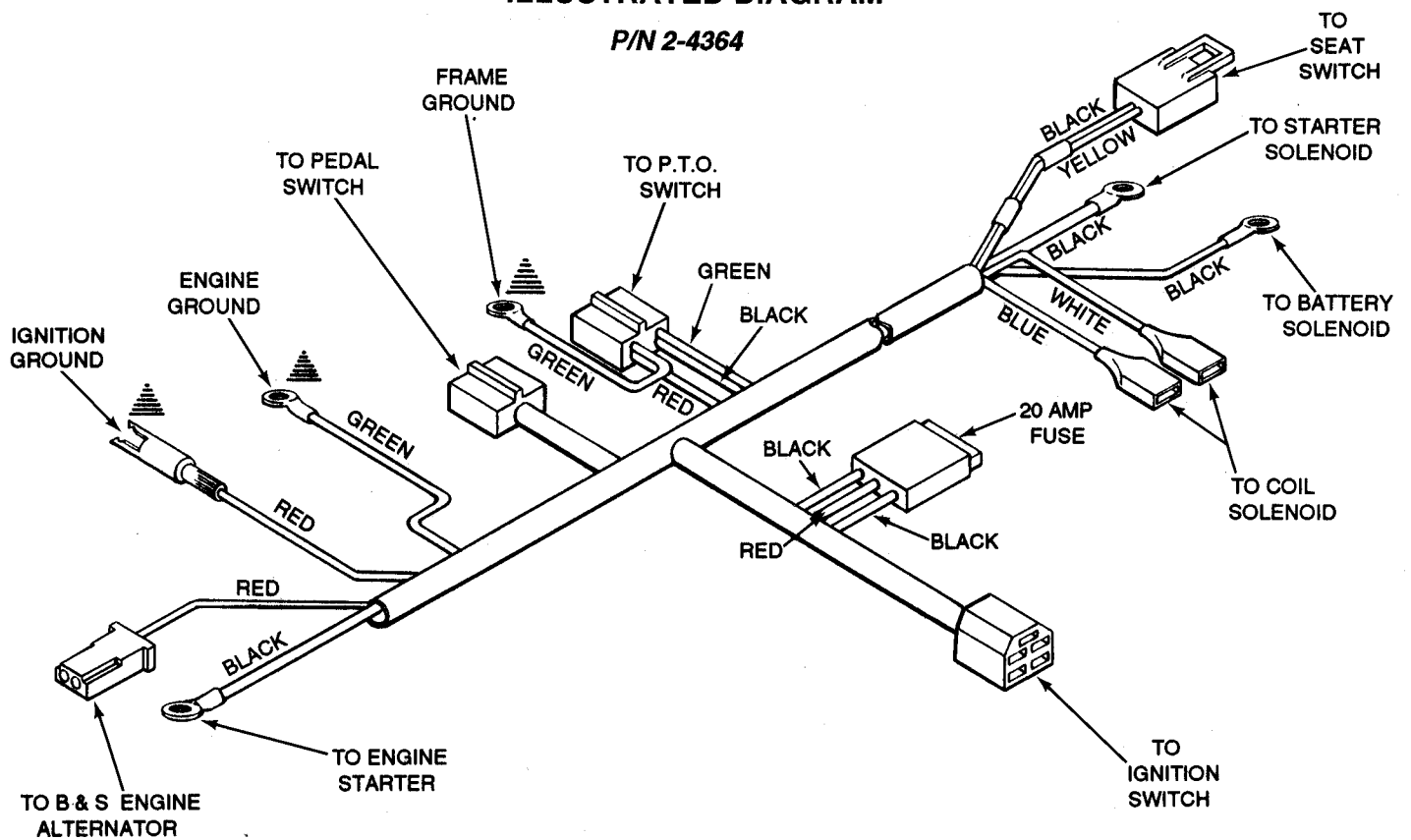

ELECTRICAL - Briggs & Stratton 12 HP Engine with Lights

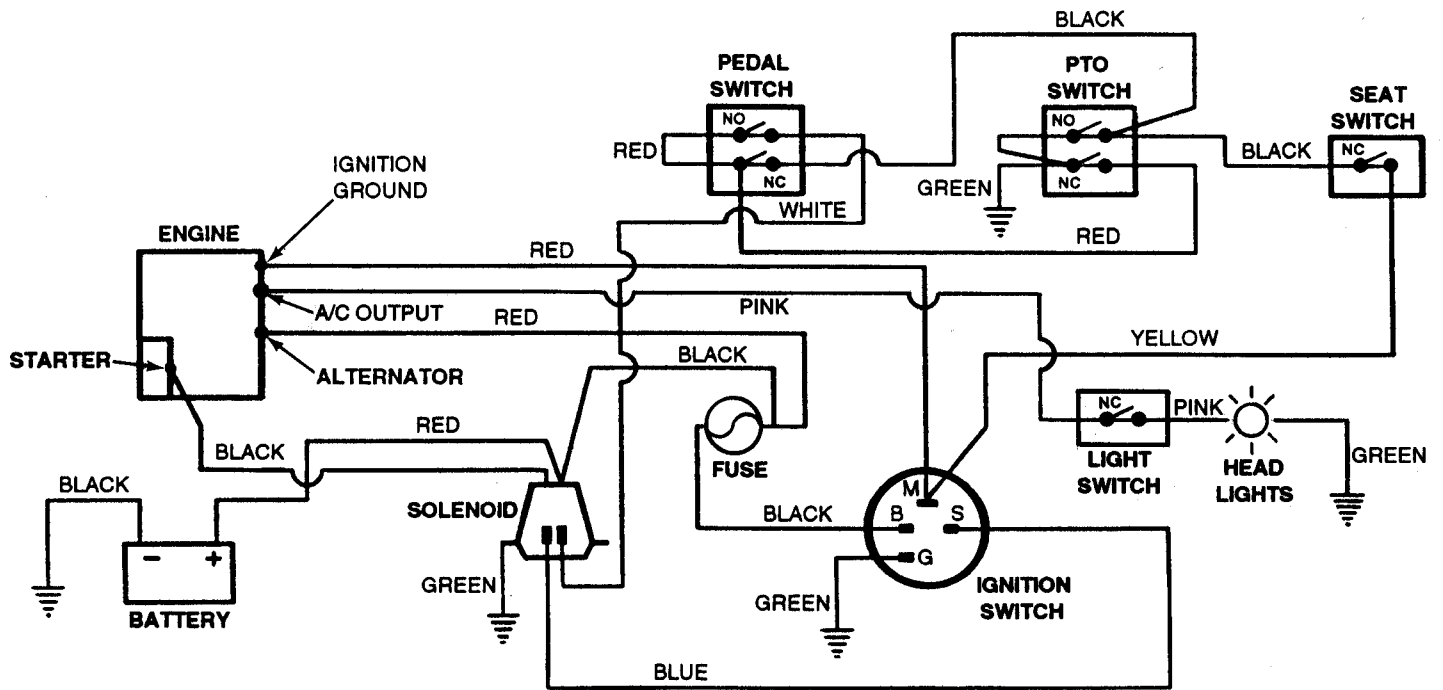

SCHEMATIC

ILLUSTRATED DIAGRAM

P/N 2-4814

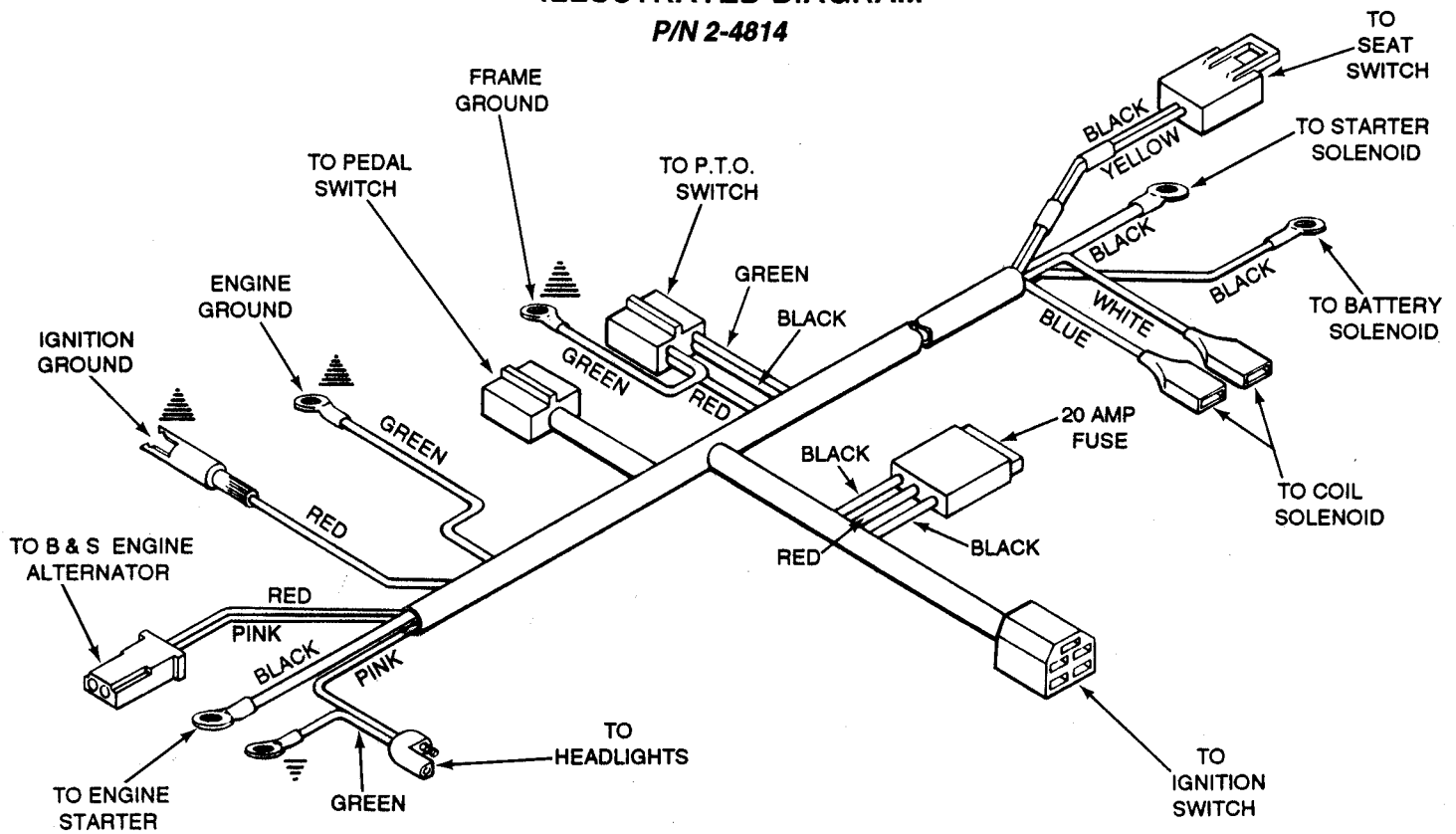

ELECTRICAL - Kohler 14 HP Engine with Lights

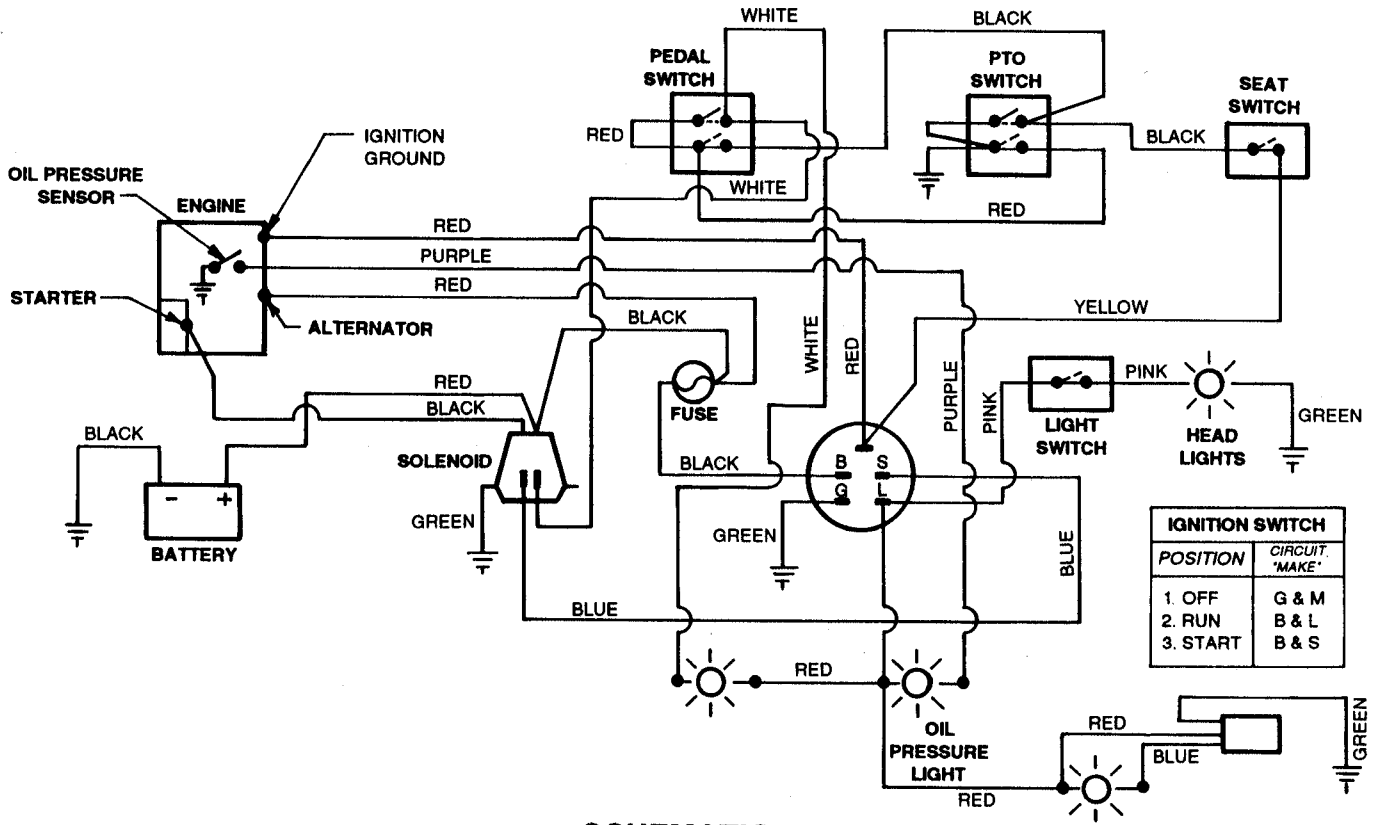

SCHEMATIC

- Ⓐ CHARGE LIGHT
- Ⓑ ALL SYSTEMS GO LIGHT
- Ⓒ OIL PRESSURE LIGHT

ILLUSTRATED DIAGRAM P/N 2-4815

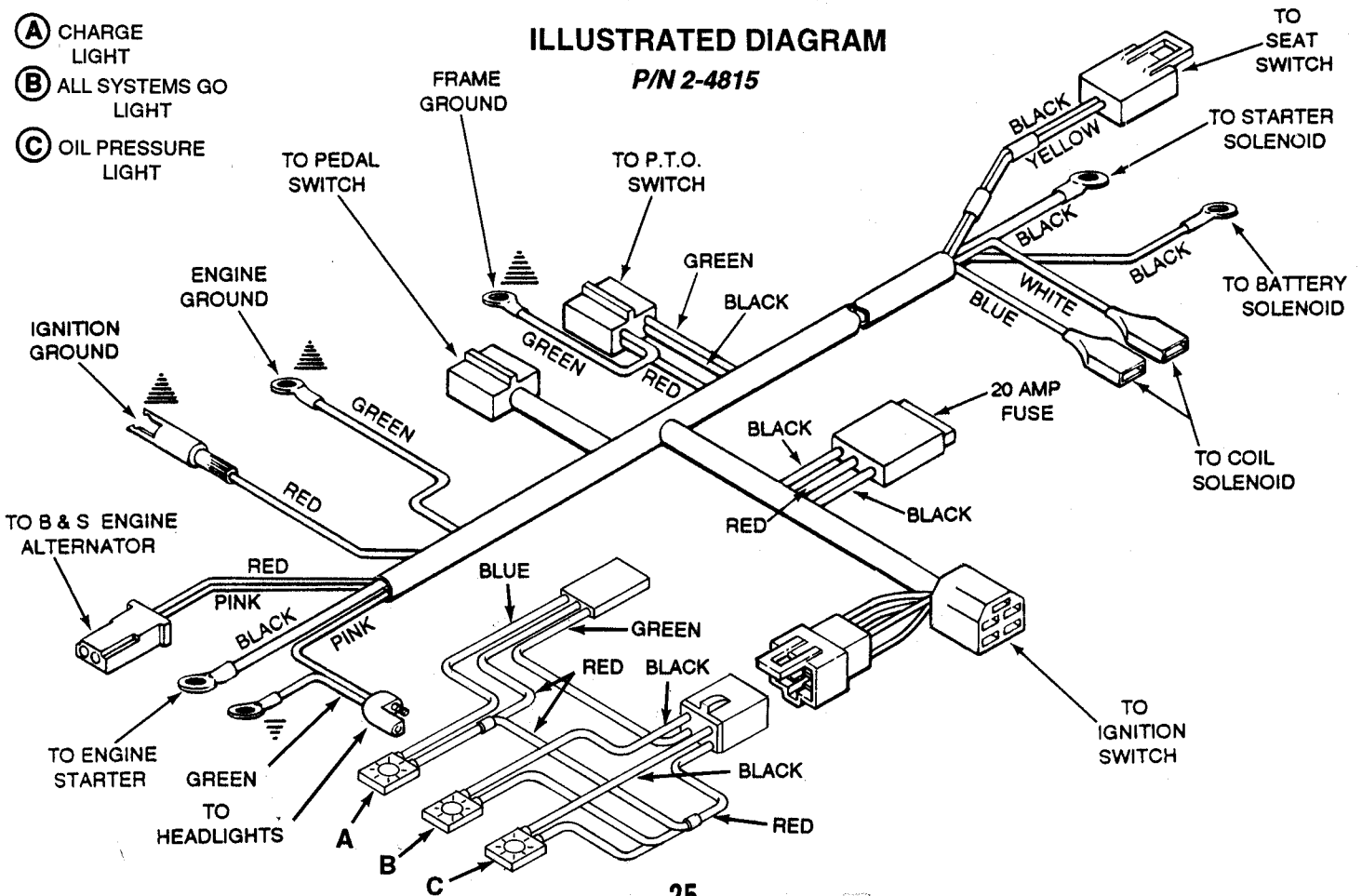

ELECTRICAL - Briggs & Stratton 14 HP Engine with Lights

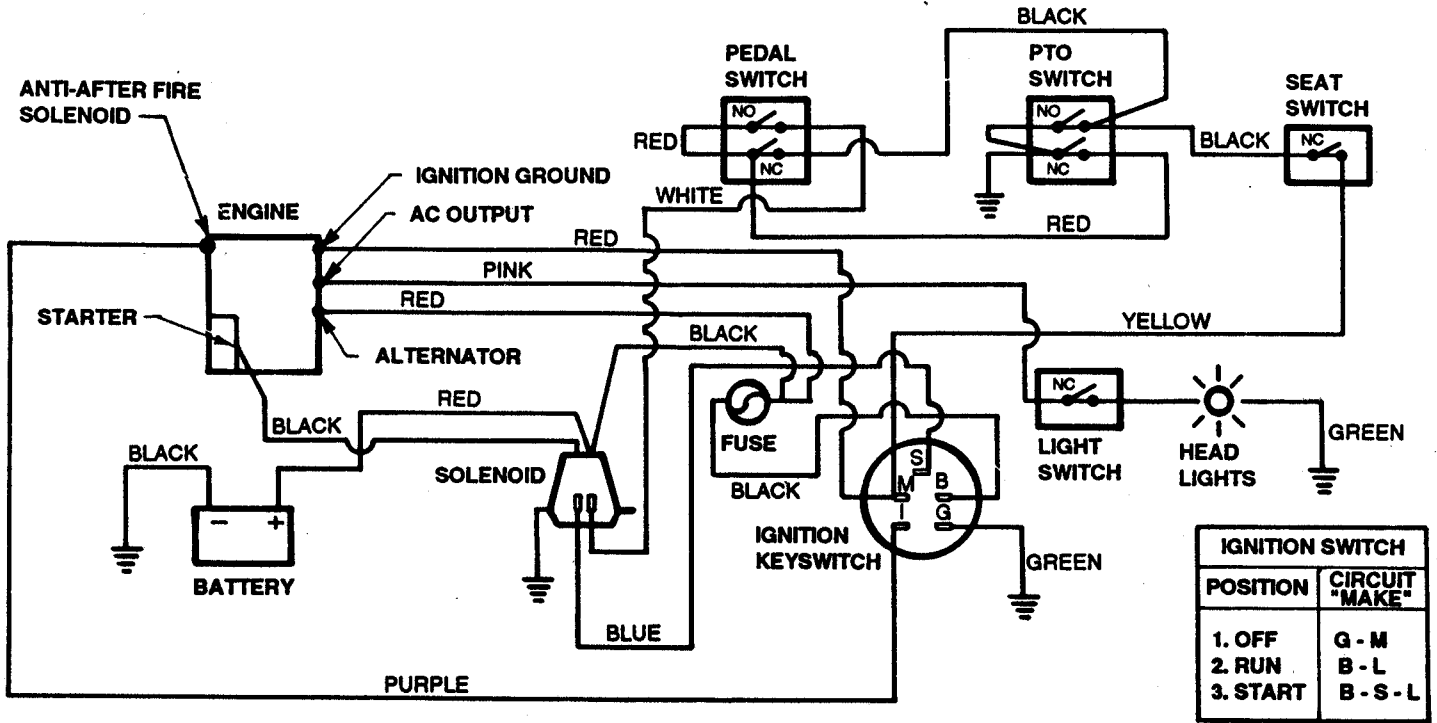

SCHEMATIC

ILLUSTRATED DIAGRAM

P/N 2-6616

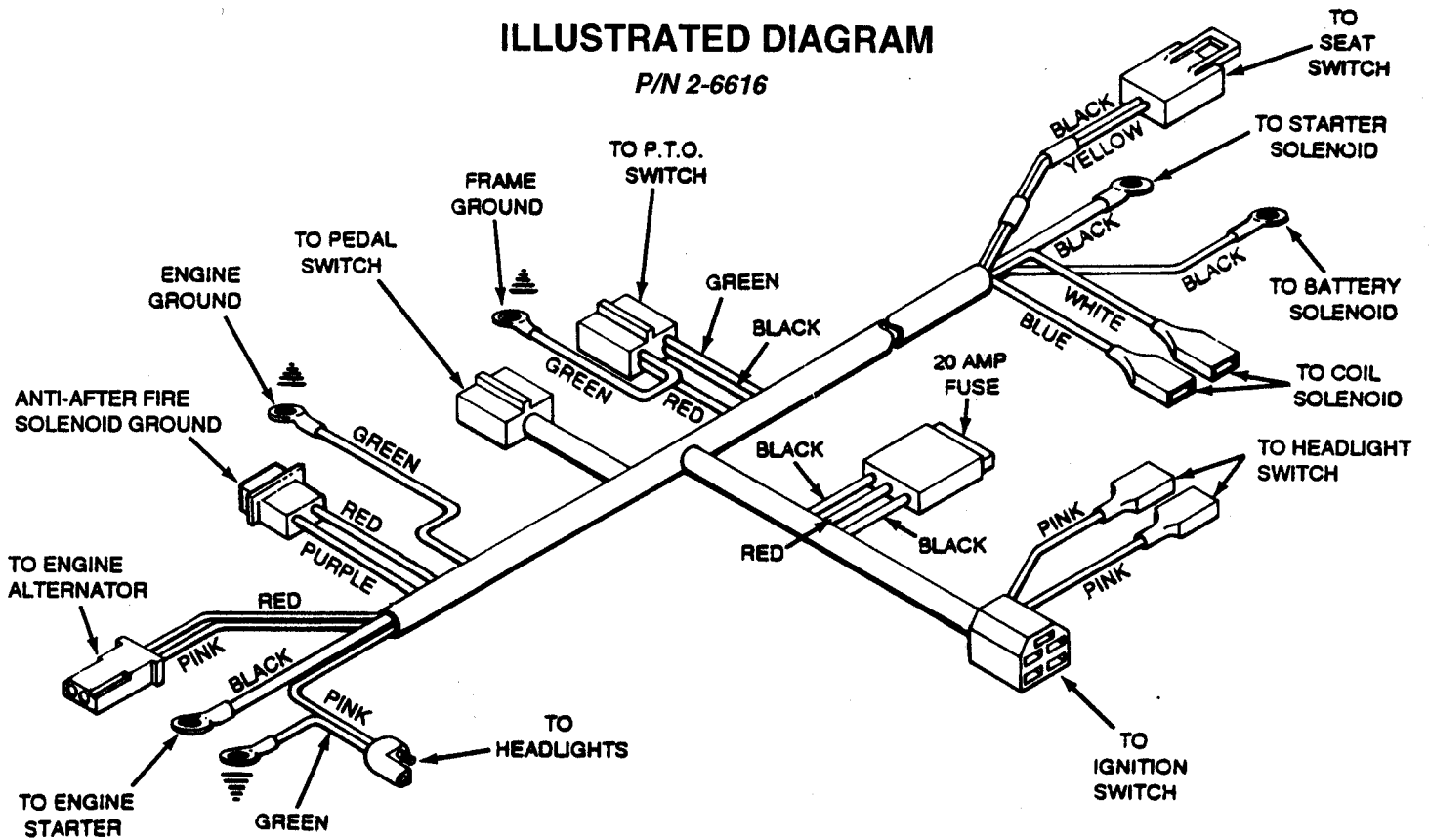

NOTES

SNAPPER®

**LT120G30AB, LT125G38AB,
LT140G38ABV, LT140G42AKV &
LT150G42AKV SERIES "A"
LAWN TRACTORS**

SNAPPER®

2 YEAR LIMITED WARRANTY

For two (2) years from purchase date for the original purchaser's residential, non-commercial use, SNAPPER, through any SNAPPER dealer will replace, free of charge, any part or parts found upon examination by the factory at McDonough, Georgia, to be defective in material or workmanship or both.

For ninety (90) days from purchase date for the original purchaser's commercial, rental, or other non-residential use, SNAPPER, through any SNAPPER dealer will replace, free of charge, any part or parts found upon examination by the factory at McDonough, Georgia, to be defective in material or workmanship or both.

All transportation costs incurred by the purchaser in submitting material to a SNAPPER dealer for replacement under this warranty must be paid by the purchaser.

This warranty does not apply to engines and their components, or, Peerless® Transaxles, as these items are warranted separately by their manufacturers. This warranty does not apply to parts that have been damaged by accident, alteration, abuse, improper lubrication, normal wear, or other cause beyond our control.

There is no other express warranty.

Implied warranties, including those of merchantability and fitness for a particular purpose, are limited to two (2) years from purchase date for the original purchaser's residential, non-commercial use [ninety (90) days from purchase for the original purchaser's commercial, rental or other non-residential use], and to the extent permitted by law, any and all implied warranties are excluded. This is the exclusive remedy. Liabilities for consequential damages, under any and all warranties are excluded.

Some states do not allow limitations on how long an implied warranty lasts, or do not allow the exclusion or limitation of incidental or consequential damages, so the above limitation or exclusion may not apply to you.

This warranty gives you specific legal rights, and you may also have other rights which vary from state to state.

WARNING: THE USE OF REPLACEMENT PARTS OTHER THAN GENUINE SNAPPER PARTS MAY IMPAIR THE SAFETY OF SNAPPER PRODUCTS AND WILL VOID ANY LIABILITY AND WARRANTY BY SNAPPER ASSOCIATED WITH THE USE OF SUCH PARTS.

IMPORTANT: Please fill out the attached SNAPPER Product Registration Card immediately and mail to:
SNAPPER, McDONOUGH, GEORGIA 30253

SNAPPER® McDonough, GA., 30253 U.S.A.