



# OPERATOR'S MANUAL



## LT-200 Series

### 18.5HP Hydro Tractors

Mfg. No.	Description
2690685	ELT18538, 18.5HP (CE)
2690781	ELT18540, 18.5HP (CE)

### 20HP Hydro Tractors

Mfg. No.	Description
2690689	ELT2044, 20HP (CE)

### 38" Mower Decks

Mfg. No.	Description
1695146	38" Mower Deck (CE)

### 40" Mower Decks

Mfg. No.	Description
1695433	40" Mower Deck (CE)

### 44" Mower Decks

Mfg. No.	Description
1695147	44" Mower Deck (CE)

1734103

Revision 02

Rev. Date 02/2008

TP 100-4422-02-RG-N



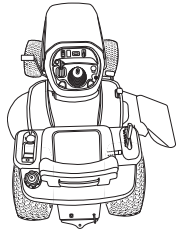

# Table of Contents

<b>Safety Rules &amp; Information</b> .....	<b>2</b>	<b>Troubleshooting, Adjustment &amp; Service</b> .....	<b>28</b>
<b>Identification Numbers</b> .....	<b>7</b>	Troubleshooting the Tractor .....	28
<b>Safety Decals</b> .....	<b>8</b>	Troubleshooting the Mower .....	29
<b>Safety Icons</b> .....	<b>9</b>	Battery Charging .....	30
<b>Features &amp; Controls</b> .....	<b>10</b>	Seat Adjustment.....	30
Control Functions .....	10	Brake Adjustment.....	30
Parking Brake Function.....	12	PTO Clutch Adjustment .....	31
Cruise Control Operation .....	12	Fuse Replacement.....	32
Hourmeter .....	12	Mower Adjustments .....	32
12 Volt Power Outlet .....	12	Gauge Wheels .....	32
<b>Operating the Tractor</b> .....	<b>13</b>	Leveling the Mower .....	33
Safety Interlock System .....	13	Mower Belt Replacement.....	34
General Operating Safety .....	13	<b>Specifications</b> .....	<b>35</b>
Adding Fuel.....	13	<b>Parts &amp; Accessories</b> .....	<b>36</b>
Starting the Engine .....	13	<b>Lawn Care &amp; Mowing Information</b> .....	<b>LC—1</b>
Stopping the Tractor & Engine.....	14		
Driving the Tractor .....	14		
Mowing.....	14		
Mowing in Reverse .....	14		
Attachment Operation in Reverse.....	14		
Pushing the Tractor by Hand .....	14		
Mower Deck Removal & Installation .....	15		
Adjusting Mower Cutting Height.....	16		
Attaching a Trailer .....	16		
Storage .....	16		
<b>Regular Maintenance</b> .....	<b>17</b>		
Maintenance Schedule .....	17		
Checking Tire Pressures.....	17		
Check / Clean Oil Cooler .....	18		
Safety Interlock System Check.....	18		
Blade Brake Check .....	18		
PTO Clutch Adjustment Check .....	18		
Engine Maintenance .....	18		
Battery Maintenance .....	18		
Transmission Identification .....	19		
Transmission Maintenance .....	19		
Hood Removal and Installation .....	19		
Lubrication .....	20		
Lubricate Rear Axes .....	21		
Servicing the Mower Blades .....	22		
Check & Fill Engine Oil .....	23		
Oil Drain Valve Operation .....	24		
Change Engine Oil .....	24		
Change Engine Oil & Filter .....	24		
Air Filter & Pre-Cleaner Service (Briggs & Stratton Two Cylinder Models).....	25		
Air Filter & Pre-Cleaner Service (Briggs & Stratton Single Cylinder Models).....	26		
Replace Spark Plug .....	27		

*NOTE: In this manual, “left” and “right” are referred to as seen from the operating position.*

# Safety Rules & Information



## Operating Safety



Congratulations on purchasing a superior-quality piece of lawn and garden equipment. Our products are designed and manufactured to meet or exceed all industry standards for safety.

Power equipment is only as safe as the operator. If it is misused, or not properly maintained, it can be dangerous! Remember, you are responsible for your safety and that of those around you.

Use common sense, and think through what you are doing. If you are not sure that the task you are about to perform can be safely done with the equipment you have chosen, ask a professional: contact your local authorized dealer.

## Read the Manual

The operator's manual contains important safety information you need to be aware of **BEFORE** you operate your unit as well as **DURING** operation.

Safe operating techniques, an explanation of the product's features and controls, and maintenance information is included to help you get the most out of your equipment investment.

Be sure to completely read the Safety Rules and Information found on the following pages. Also completely read the Operation section.



## Children

Tragic accidents can occur with children. Do not allow them anywhere near the area of operation. Children are often attracted to the unit and mowing activity. Never assume that children will remain where you last saw them. If there is a risk that children may enter the area where you are mowing, have another responsible adult watch them.

**DO NOT GIVE CHILDREN RIDES ON THIS UNIT!** This encourages them to come near the unit in the future while it is running, and they could be seriously hurt. They may then approach the unit for a ride when you are not expecting it, and you may run over them.

TP 600-2459-08-UV-SMA

## Reverse

Do not mow in reverse unless absolutely necessary. Always look down and behind before and while traveling in reverse even with the mower blades disengaged.



## Slope Operation

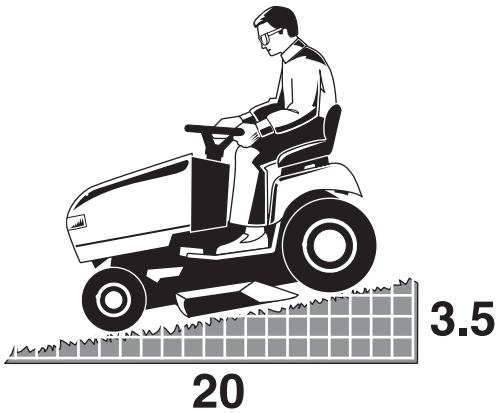

You could be seriously injured or even killed if you use this unit on too steep an incline. Using the unit on a slope that is too steep or where you don't have adequate traction can cause you to lose control or roll over.

A good rule of thumb is to not operate on any slope you cannot back up (in 2-wheel drive mode). You should not operate on inclines with a slope greater than a 3.5 foot rise over a 20 foot length. Always drive up and down slopes: never cross the face.

Also note that the surface you are driving on can greatly impact stability and control. Wet grass or icy pavement can seriously affect your ability to control the unit.

If you feel unsure about operating the unit on an incline, don't do it. It's not worth the risk.

## Moving Parts

This equipment has many moving parts that can injure you or someone else. However, if you are seated in the seat properly, and follow all the rules in this book, the unit is safe to operate.

The mower deck has spinning mower blades that can amputate hands and feet. Do not allow anyone near the equipment while it is running!

To help you, the operator, use this equipment safely, it is equipped with an operator-present safety system. Do NOT attempt to alter or bypass the system. See your dealer immediately if the system does not pass all the safety interlock system tests found in this manual.

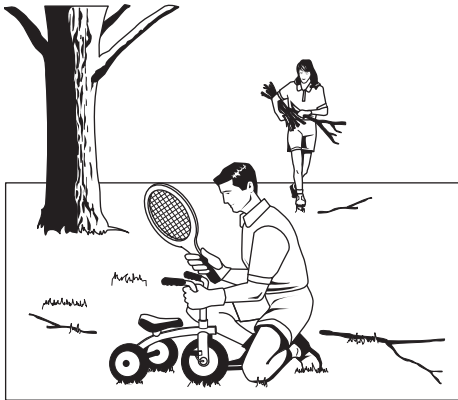

## Thrown Objects

This unit has spinning mower blades. These blades can pick up and throw debris that could seriously injure a bystander. Be sure to clean up the area to be mowed BEFORE you start mowing.

Do not operate this unit without the entire grass catcher or discharge guard (deflector) in place.

Also, do not allow anyone in the area while the unit is running! If someone does enter the area, shut the unit off immediately until they leave.

## Fuel and Maintenance

Gasoline is extremely flammable. Its vapors are also extremely flammable and can travel to distant ignition sources. Gasoline must only be used as a fuel, not as a solvent or cleaner. It should never be stored any place where its vapors can build up or travel to an ignition source like a pilot light. Fuel belongs in an approved, plastic, sealed gas can, or in the tractor fuel tank with the cap securely closed. Spilled fuel needs to be cleaned up immediately.

Proper maintenance is critical to the safety and performance of your unit. Be sure to perform the maintenance procedures listed in this manual, especially periodically testing the safety system.

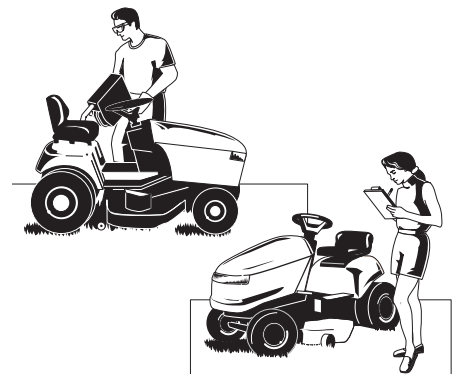

# Safety Rules & Information

---



Read these safety rules and follow them closely. Failure to obey these rules could result in loss of control of unit, severe personal injury or death to you, or bystanders, or damage to property or equipment.

**This mowing deck is capable of amputating hands and feet and throwing objects.**

The triangle  in text signifies important cautions or warnings which must be followed.

## GENERAL OPERATION

1. Read, understand, and follow all instructions in the manual and on the unit before starting.
2. Do not put hands or feet near rotating parts or under the machine. Keep clear of the discharge opening at all times.
3. Only allow responsible adults, who are familiar with the instructions, to operate the unit (local regulations can restrict operator age).
4. Clear the area of objects such as rocks, toys, wire, etc., which could be picked up and thrown by the blade(s).
5. Be sure the area is clear of other people before mowing. Stop the unit if anyone enters the area.
6. Never carry passengers.
7. Do not mow in reverse unless absolutely necessary. Always look down and behind before and while travelling in reverse.
8. Never direct discharge material toward anyone. Avoid discharging material against a wall or obstruction. Material may ricochet back toward the operator. Stop the blade(s) when crossing gravel surfaces.
9. Do not operate the machine without the entire grass catcher, discharge guard (deflector), or other safety devices in place.
10. Slow down before turning.
11. Never leave a running unit unattended. Always disengage the PTO, set parking brake, stop engine, and remove keys before dismounting.
12. Disengage blades (PTO) when not mowing. Shut off engine and wait for all parts to come to a complete stop before cleaning the machine, removing the grass catcher, or unclogging the discharge guard.
13. Operate the machine only in daylight or good artificial light.
14. Do not operate the unit while under the influence of alcohol or drugs.
15. Watch for traffic when operating near or crossing roadways.
16. Use extra care when loading or unloading the unit into a trailer or truck.
17. Always wear eye protection when operating this unit.
18. Data indicates that operators, age 60 years and above, are involved in a large percentage of power equipment-related injuries. These operators should evaluate their ability to operate the equipment safely enough to protect themselves and others from injury.
19. Follow the manufacturer's recommendations for wheel weights or counterweights.
20. Keep in mind the operator is responsible for accidents occurring to other people or property.
21. All drivers should seek and obtain professional and practical instruction.
22. Always wear substantial footwear and trousers. Never operate when barefoot or wearing sandals.
23. Before using, always visually check that the blades and blade hardware are present, intact, and secure. Replace worn or damaged parts.
24. Disengage attachments before: refueling, removing an attachment, making adjustments (unless the adjustment can be made from the operator's position).
25. When the machine is parked, stored, or left unattended, lower the cutting means unless a positive mechanical lock is used.
26. Before leaving the operator's position for any reason, engage the parking brake (if equipped), disengage the PTO, stop the engine, and remove the key.
27. To reduce fire hazard, keep the unit free of grass, leaves, & excess oil. Do not stop or park over dry leaves, grass, or combustible materials.
28. It is a violation of California Public Resource Code Section 4442 to use or operate the engine on or near any forest-covered, brush-covered, or grass-covered land unless the exhaust system is equipped with a spark arrester meeting any applicable local or state laws. Other states or federal areas may have similar laws.

---

## TRANSPORTING AND STORAGE

1. When transporting the unit on an open trailer, make sure it is facing forward, in the direction of travel. If the unit is facing backwards, wind lift could damage the unit.
2. Always observe safe refueling and fuel handling practices when refueling the unit after transportation or storage.
3. Never store the unit (with fuel) in an enclosed poorly ventilated structure. Fuel vapors can travel to an ignition source (such as a furnace, water heater, etc.) and cause an explosion. Fuel vapor is also toxic to humans and animals.
4. Always follow the engine manual instructions for storage preparations before storing the unit for both short and long term periods.
5. Always follow the engine manual instructions for proper start-up procedures when returning the unit to service.
6. Never store the unit or fuel container inside where there is an open flame or pilot light, such as in a water heater. Allow unit to cool before storing.

## SLOPE OPERATION

Slopes are a major factor related to loss-of-control and tip-over accidents, which can result in severe injury or death. Operation on all slopes requires extra caution. If you cannot back up the slope or if you feel uneasy on it, do not operate on it.

Control of a walk-behind or ride-on machine sliding on a slope will not be regained by the application of the brake. The main reasons for loss of control are: insufficient tire grip on the ground, speed too fast, inadequate braking, the type of machine is unsuitable for its task, lack of awareness of the ground conditions, incorrect hitching and load distribution.

1. Mow up and down slopes, not across.
2. Watch for holes, ruts, or bumps. Uneven terrain could overturn the unit. Tall grass can hide obstacles.
3. Choose a slow speed so that you will not have to stop or change speeds while on the slope.
4. Do not mow on wet grass. Tires may lose traction.
5. Always keep unit in gear especially when traveling down slopes. Do not shift to neutral and coast downhill.
6. Avoid starting, stopping, or turning on a slope. If tires lose traction, disengage the blade(s) and proceed slowly straight down the slope.
7. Keep all movement on slopes slow and gradual. Do not make sudden changes in speed or direction, which could cause the machine to rollover.
8. Use extra care while operating machines with grass catchers or other attachments; they can affect the stability of the unit. Do not use on steep slopes.
9. Do not try to stabilize the machine by putting your foot on the ground (ride-on units).
10. Do not mow near drop-offs, ditches, or embankments. The mower could suddenly turn over if a wheel is over the edge of a cliff or ditch, or if an edge caves in.
11. Do not use grass catchers on steep slopes.
12. Do not mow slopes you cannot back up them.
13. See your authorized dealer/retailer for recommendations of wheel weights or counterweights to improve stability.
14. Remove obstacles such as rocks, tree limbs, etc.
15. Use slow speed. Tires may lose traction on slopes even through the brakes are functioning properly.
16. Do not turn on slopes unless necessary, and then, turn slowly and gradually downhill, if possible.

## TOWED EQUIPMENT (RIDE-ON UNITS)

1. Tow only with a machine that has a hitch designed for towing. Do not attach towed equipment except at the hitch point.
2. Follow the manufacturer's recommendations for weight limit for towed equipment and towing on slopes.
3. Never allow children or others in or on towed equipment.
4. On slopes, the weight of the towed equipment may cause loss of traction and loss of control.
5. Travel slowly and allow extra distance to stop.
6. Do not shift to neutral and coast down hill.

## WARNING

Never operate on slopes greater than 17.6 percent (10°) which is a rise of 3-1/2 feet (106 cm) vertically in 20 feet (607 cm) horizontally.

When operating on slopes use additional wheel weights or counterweights. See your dealer/retailer to determine which weights are available and appropriate for your unit.

Select slow ground speed before driving onto slope. In addition to front weights, use extra caution when operating on slopes with rear-mounted grass catchers.

Mow UP and DOWN the slope, never across the face, use caution when changing directions and **DO NOT START OR STOP ON SLOPE.**

## CHILDREN

Tragic accidents can occur if the operator is not alert to the presence of children. Children are often attracted to the unit and the mowing activity. Never assume that children will remain where you last saw them.

1. Keep children out of the mowing area and under the watchful care of another responsible adult.
2. Be alert and turn unit off if children enter the area.
3. Before and during reverse operation, look behind and down for small children.
4. Never carry children, even with the blade(s) off. They may fall off and be seriously injured or interfere with safe unit operation. Children who have been given rides in the past may suddenly appear in the mowing area for another ride and be run over or backed over by the machine.
5. Never allow children to operate the unit.
6. Use extra care when approaching blind corners, shrubs, trees, or other objects that may obscure vision.

## EMISSIONS

1. Engine exhaust from this product contains chemicals known, in certain quantities, to cause cancer, birth defects, or other reproductive harm.
2. Look for the relevant Emissions Durability Period and Air Index information on the engine emissions label.

## IGNITION SYSTEM

1. This spark ignition system complies with Canadian ICES-002.

# Safety Rules & Information

---

## SERVICE AND MAINTENANCE

### Safe Handling of Gasoline

1. Extinguish all cigarettes, cigars, pipes, and other sources of ignition.
2. Use only approved gasoline containers.
3. Never remove the gas cap or add fuel with the engine running. Allow the engine to cool before refueling.
4. Never fuel the machine indoors.
5. Never store the machine or fuel container where there is an open flame, spark, or pilot light such as near a water heater or other appliance.
6. Never fill containers inside a vehicle or on a truck bed with a plastic bed liner. Always place containers on the ground away from your vehicle before filling.
7. Remove gas-powered equipment from the truck or trailer and refuel it on the ground. If this is not possible, then refuel such equipment on a trailer with a portable container, rather than from a gasoline dispenser nozzle.
8. Keep nozzle in contact with the rim of the fuel tank or container opening at all times until fueling is complete. Do not use a nozzle lock-open device.
9. If fuel is spilled on clothing, change clothing immediately.
10. Never over-fill the fuel tank. Replace gas cap and tighten securely.
11. Use extra care in handling gasoline and other fuels. They are flammable and vapors are explosive.
12. If fuel is spilled, do not attempt to start the engine but move the machine away from the area of spillage and avoid creating any source of ignition until fuel vapors have dissipated.
13. Replace all fuel tank caps and fuel container caps securely.
13. If the fuel tank must be drained, it should be drained outdoors.
14. Replace faulty silencers/mufflers.
15. Use only factory authorized replacement parts when making repairs.
16. Always comply with factory specifications on all settings and adjustments.
17. Only authorized service locations should be utilized for major service and repair requirements.
18. Never attempt to make major repairs on this unit unless you have been properly trained. Improper service procedures can result in hazardous operation, equipment damage and voiding of manufacturer's warranty.
19. On multiple blade mowers, take care as rotating one blade can cause other blades to rotate.
20. Do not change engine governor settings or over-speed the engine. Operating the engine at excessive speed can increase the hazard of personal injury.
21. Disengage drive attachments, stop the engine, remove the key, and disconnect the spark plug wire(s) before: clearing attachment blockages and chutes, performing service work, striking an object, or if the unit vibrates abnormally. After striking an object, inspect the machine for damage and make repairs before restarting and operating the equipment.
22. Never place hands near the moving parts, such as a hydro pump cooling fan, when the tractor is running. (Hydro pump cooling fans are typically located on top of the transaxle).
23. Units with hydraulic pumps, hoses, or motors:  
**WARNING:** Hydraulic fluid escaping under pressure may have sufficient force to penetrate skin and cause serious injury. If foreign fluid is injected into the skin it must be surgically removed within a few hours by a doctor familiar with this form of injury or gangrene may result. Keep body and hands away from pin holes or nozzles that eject hydraulic fluid under high pressure. Use paper or cardboard, and not hands, to search for leaks. Make sure all hydraulic fluid connections are tight and all hydraulic hoses and lines are in good condition before applying pressure to the system. If leaks occur, have the unit serviced immediately by your authorized dealer.

### Service & Maintenance

1. Never run the unit in an enclosed area where carbon monoxide fumes may collect.
2. Keep nuts and bolts, especially blade attachment bolts, tight and keep equipment in good condition.
3. Never tamper with safety devices. Check their proper operation regularly and make necessary repairs if they are not functioning properly.
4. Keep unit free of grass, leaves, or other debris build-up. Clean up oil or fuel spillage. and remove any fuel-soaked debris. Allow machine to cool before storage.
5. If you strike an object, stop and inspect the machine. Repair, if necessary, before restarting.
6. Never make adjustments or repairs with the engine running.
7. Check grass catcher components and the discharge guard frequently and replace with manufacturer's recommended parts, when necessary.
8. Mower blades are sharp. Wrap the blade or wear gloves, and use extra caution when servicing them.
9. Check brake operation frequently. Adjust and service as required.
10. Maintain or replace safety and instructions labels, as necessary.
11. Do not remove the fuel filter when the engine is hot as spilled gasoline may ignite. Do not spread fuel line clamps further than necessary. Ensure clamps grip hoses firmly over the filter after installation.
12. Do not use gasoline containing METHANOL, gasohol containing more than 10% ETHANOL, gasoline additives, or white gas because engine/fuel system damage could result.
24. **WARNING:** Stored energy device. Improper release of springs can result in serious personal injury. Springs should be removed by an authorized technician.
25. Models equipped with an engine radiator: **WARNING:** Stored energy device. To prevent serious bodily injury from hot coolant or steam blow-out, never attempt to remove the radiator cap while the engine is running. Stop the engine and wait until it is cool. Even then, use extreme care when removing the cap.



# Identification Numbers

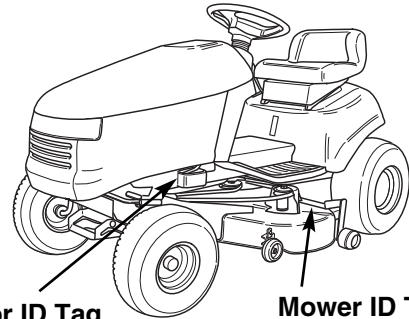
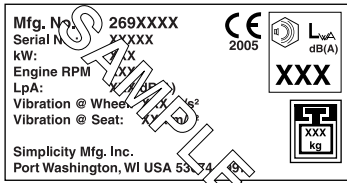

Tractor ID Tag

Mower ID Tag

When contacting your authorized dealer for replacement parts, service, or information you **MUST** have these numbers.

Record your model name/number, manufacturer's identification numbers, and engine serial numbers in the space provided for easy access. These numbers can be found in the locations shown.

*NOTE: For location of engine identification numbers, refer to the engine owner's manual.*

CE Models: Place the extra copy of the identification tag in the manual

PRODUCT REFERENCE DATA	
Model Description Name/Number	
Unit MFG Number	Unit SERIAL Number
Mower Deck MFG Number	Mower Deck SERIAL Number
Dealer Name	Date Purchased
ENGINE REFERENCE DATA	
Engine Make	Engine Model
Engine Type/Spec	Engine Code/Serial Number

## CE Identification Tag Markings

- A. Manufacturer's Identification Number
- B. Manufacturer's Serial Number
- C. Power Rating in Kilowatts
- D. Maximum Engine Speed in Rotations per Minute
- E. Manufacturer's Address
- F. Year of Manufacture
- G. CE Compliance Logo
- H. Mass of Unit in Kilograms
- I. Sound Power in Decibels \*\*\*
- J. Sound Pressure at Operator's Position in Decibels \*\*
- K. Vibration at the Steering Wheel \*

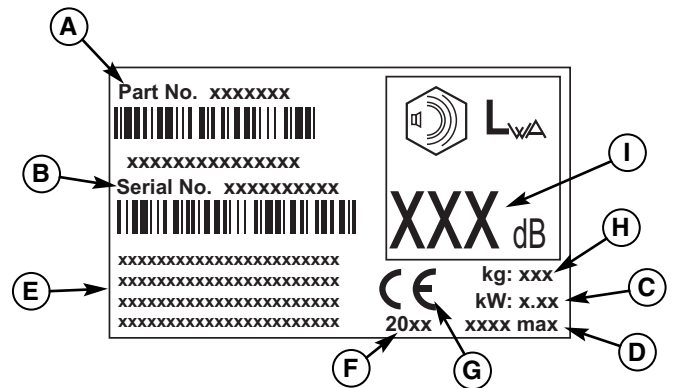

# Safety Decals

## Safety Decals

This unit has been designed and manufactured to provide you with the safety and reliability you would expect from an industry leader in outdoor power equipment manufacturing.

Although reading this manual and the safety instructions it contains will provide you with the necessary basic knowledge to operate this equipment safely and effectively, we have placed several safety labels on the unit to remind you of this important information while you are operating your unit.

All DANGER, WARNING, CAUTION and instructional messages on your rider and mower should be carefully read and obeyed. Personal bodily injury can result when these instructions are not followed. The information is for your safety and it is important! The safety decals below are on your rider and mower.

If any of these decals are lost or damaged, replace them at once. See your local dealer for replacements.

These labels are easily applied and will act as a constant visual reminder to you, and others who may use the equipment, to follow the safety instructions necessary for safe, effective operation.

## Safety Icons

### Warning: Read Operator's Manual.

Read and understand the Operator's Manual before using this machine.



### Danger: Machine Rollover.

Do not use this machine on slopes greater than 10°.



### Danger: Thrown Objects.

This machine is capable of throwing objects and debris. Keep bystanders away.



### Danger: Dismemberment.

This machine can amputate limbs. Keep bystanders and children away when engine is running.



### Warning: Remove Key Before Servicing.

Remove the key and consult technical literature before performing repairs or maintenance.



### Danger: Dismemberment.

This mower deck can amputate limbs. Keep hands and feet away from blades.



**Decals Locations**

Operating Instructions,  
CE Models, Part No. 1734027



**Ignition Switch Positions**  
Part No. 1722806

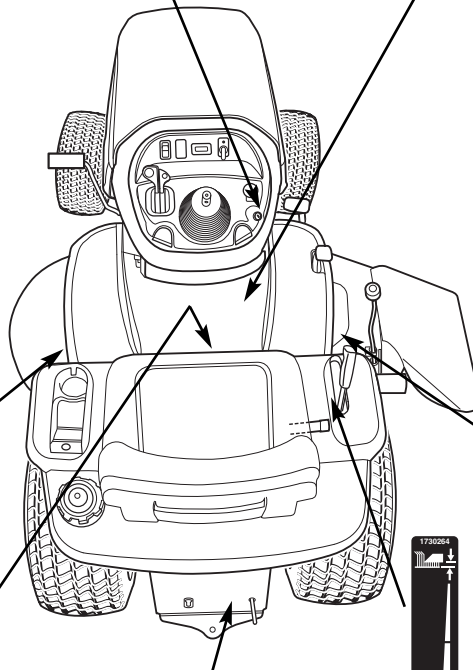

**Caution, Pinch Point**  
Part No. 1732070  
(38", 40" & 44" Mowers Only)



**Caution, Pinch Point**  
Part No. 1732070  
(38", 40" & 44" Mowers Only)



**Fuel Level**  
Part No. 1730172



**Transmission Release**  
Part No. 1730202



**Attachment Lift**  
Part No. 1730264

# Features & Controls

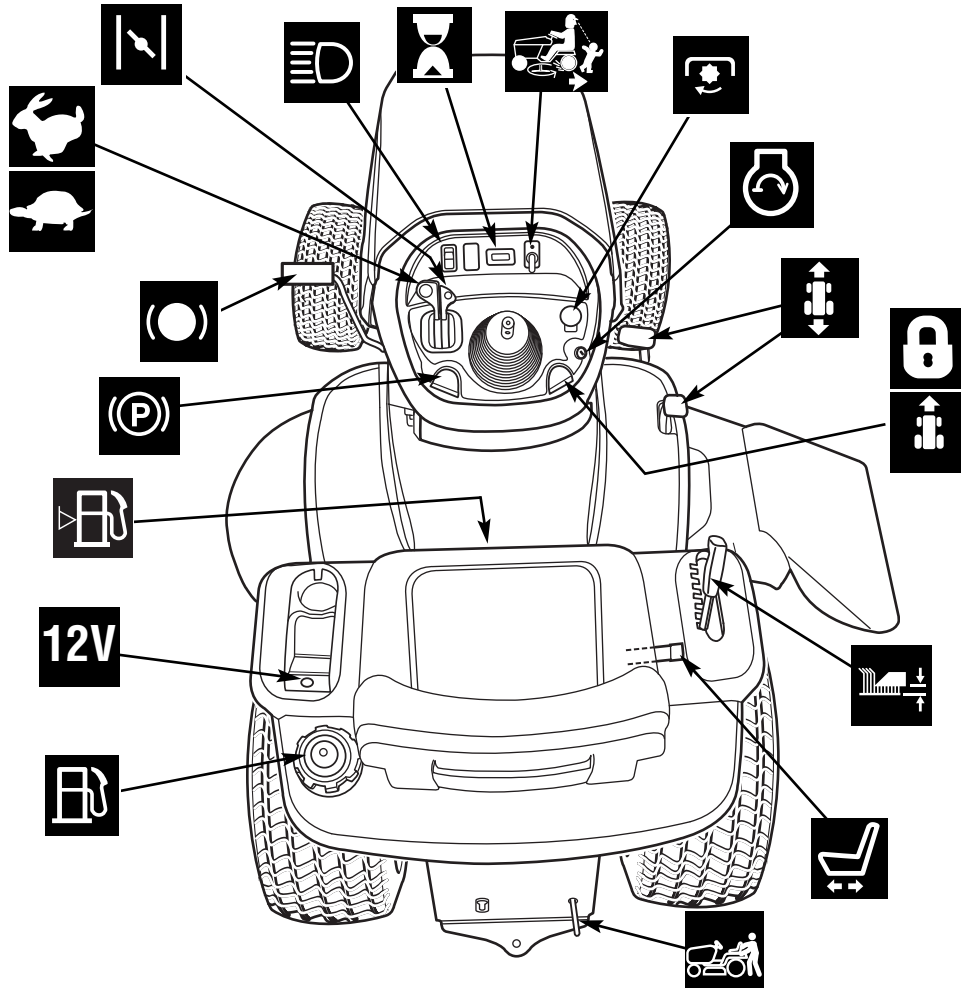

Figure 1. Controls

## Control Functions

The information below briefly describes the function of individual controls. Starting, stopping, driving, and mowing require the combined use of several controls applied in specific sequences. To learn what combination and sequence of controls to use for various tasks see the OPERATION section.



### Throttle Control

The throttle controls engine speed. Move the throttle forward to increase engine speed and back to decrease engine speed. Always operate at FULL throttle.



### Choke

Close the choke for cold starting. Open the choke once the engine starts. A warm engine may not require choking. Move the lever forward to close the choke.



### Headlights

The light switch turns the tractor headlights on and off.



### Hour Meter (Select Models)

The hour meter measures the number of hours the key has been in the RUN position.



## Reverse Mowing Option (RMO)

The Reverse Mowing Option allows for mowing (or use of other PTO driven attachments) while traveling in reverse. If you choose to mow in reverse, turn the RMO key after the PTO is engaged. The L.E.D. light will illuminate, and the operator can then mow in reverse. Each time the PTO is engaged the RMO needs to be reactivated if desired.



## PTO Switch

The PTO (Power Take-Off) switch engages and disengages attachments that use the PTO. To engage the PTO, pull UP on the switch. Push DOWN to disengage. *Note that the operator must be seated firmly in the tractor seat for the PTO to function.*



## Ignition Switch

The ignition switch starts and stops the engine, it has three positions:



**OFF** Stops the engine and shuts off the electrical system.



**RUN** Allows the engine to run and powers the electrical system.



**START** Cranks the engine for starting.

*NOTE: Never leave the ignition switch in the RUN position with the engine stopped—this drains the battery.*



## Ground Speed Pedals

The tractor's forward ground speed is controlled by the forward ground speed control pedal. The tractor's reverse ground speed is controlled by the reverse ground speed control pedal.

Depressing either pedal will increase ground speed. Note that the further down the pedal is depressed, the faster the tractor will travel.



## Cruise Control

The cruise control is used to lock the ground speed control in forward. The cruise control has five lock positions.



## Mower Height of Cut Adjustment

The mower cutting height adjustment lever controls the mower cutting height. The mower cutting height can be set to one of seven positions between 1-1/4" and 4."



## Seat Adjustment Lever

The seat can be adjusted forward and back. Move the lever, position the seat as desired, and release the lever to lock the seat into position.



## Transmission Release Valve Lever

The transmission release valve lever deactivates the transmission so that the tractor can be pushed by hand. See PUSHING THE TRACTOR BY HAND for operational information.



## Fuel Tank

To remove the cap, turn counterclockwise.



## 12V Power Outlet (Select Models)

The power outlet is 12V-DC. Accessory must be rated at 9 amps or less.



## Fuel Level Gauge

Displays the fuel level in the tank.



## Parking Brake

The parking brake knob is used to lock the parking brake when the tractor is stopped. Fully depressing the brake pedal and pulling up on the knob engages the parking brake. Refer to page 12 for a full explanation of parking brake functions.



## Brake Pedal

Depressing the brake pedal applies the tractor brake.

# Features & Controls

## Parking Brake Function

**Applying the Parking Brake** - See Figure 2. To lock the parking brake, release the ground speed pedals (A), fully depress the brake pedal (B), pull UP on the parking brake knob (C), and then release brake pedal.

**Releasing the Parking Brake** - See Figure 2. To release the parking brake, depress the brake pedal (B).

## Cruise Control Operation

### TO ENGAGE:

1. Pull up on the cruise control knob (D, Figure 2).
2. Depress the forward ground speed pedal (A).
3. Lift up the Cruise control knob (D) when desired speed is reached. The Cruise will lock in one of its five locking positions.

### TO DISENGAGE:

1. Depress the brake pedal (B).

### OR

2. Depress the forward ground speed pedal (A).

## Hourmeter

### (Select Models)

The hour meter (E, Figure 2) measures the number of hours the key has been in the RUN position.

## 12 Volt Power Outlet

### (Select Models)

## ⚠ CAUTION

**Avoid Injury. Safe operation requires your full attention. Do not wear radio or music headphones while operating machine.**

The 12-volt accessory plug is located in the left side pod (D, Figure 2). It can be used to power small electronic devices. The accessory must be rated at 9 amps or less.

*Note: Operating a 12-volt accessory, especially with the engine at idle, may cause battery discharge. When not using the accessory plug it must be covered with the rubber plug to prevent moisture from causing a short circuit. Entrance of water into plug can cause a short circuit.*

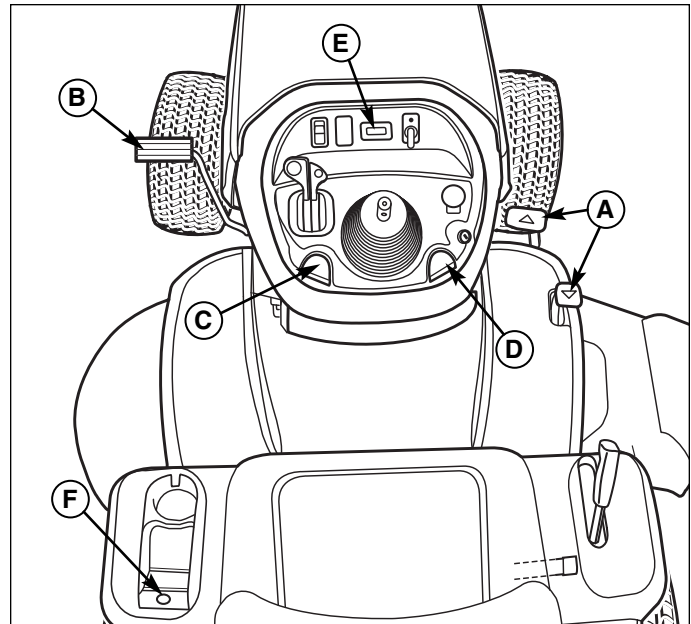

**Figure 2. Engaging the Parking Brake**

- A. Ground Speed Pedals
- B. Brake Pedal
- C. Parking Brake Knob
- D. Cruise Control Knob
- E. Hourmeter
- F. 12V Power Adapter



# Operating the Tractor



## SAFETY INTERLOCK SYSTEM TESTS

This unit is equipped with safety interlock switches and other safety devices. These safety systems are present for your safety: do not attempt to bypass safety switches, and never tamper with safety devices. Check their operation regularly.

### Operational SAFETY Checks

Your unit is equipped with a seat switch safety system. Check the seat switch operation every fall and spring with the following tests.

#### Test 1 — Engine should NOT crank if:

- PTO switch is ON, OR
- Brake pedal is NOT fully depressed (parking brake OFF), OR
- The cruise control lever is NOT in NEUTRAL.

#### Test 2 — Engine SHOULD crank and start if:

- Operator is sitting in seat, AND
- PTO switch is OFF, AND
- Brake pedal is fully depressed (parking brake ON), AND
- The cruise control lever is in NEUTRAL

#### Test 3 — Engine should SHUT OFF if:

- Operator rises off seat.

#### Test 4 — Blade Brake Check

Mower blades and mower drive belt should come to a complete stop within five seconds after electric PTO switch is turned OFF (or operator rises off seat). If mower drive belt does not stop within five seconds, readjust the PTO clutch as described in the ADJUSTMENTS section or see your dealer.

#### Test 5 — Reverse Mow Option (RMO) Check

- Engine should shut off if reverse travel is attempted if the PTO has been switched on and RMO has not been activated.
- RMO light should illuminate when RMO has been activated.

## WARNING

**If the unit does not pass a safety test, do not operate it. See your authorized dealer. Under no circumstance should you attempt to defeat the purpose of the safety interlock system.**

## General Operating Safety

Be sure to read all information in the Safety and Operation sections before attempting to operate this unit. Become familiar with all of the controls and how to stop the unit.

## Adding Fuel

### WARNING

**Gasoline is highly flammable and must be handled with care. Never fill the tank when the engine is still hot from recent operation. Do not allow open flame, smoking or matches in the area. Avoid over-filling and wipe up any spills.**



Do not use gasoline containing METHANOL, gasohol containing more than 10% ETHANOL, gasoline additives, or white gas because engine/fuel system damage could result.

To add fuel:

1. Remove the fuel cap (A, Figure 3).
2. Fill the tank. Do not overfill. Leave room in the tank for fuel expansion. Refer to your engine manual for specific fuel recommendations.
3. Install and hand tighten the fuel cap.

## Starting The Engine

1. While sitting in the operator's seat, fully depress the brake pedal or set the parking brake.
  2. Make sure that your feet are not depressing the ground speed control pedals and that the cruise control lever is in neutral.
  3. Disengage the PTO clutch.
  4. Set the throttle to FULL.
  5. Close the choke.
- NOTE: A warm engine may not require choking.*
6. Insert the ignition key and turn it to START.
  7. After the engine starts, move the engine throttle control to half speed. Warm up the engine by running it for at least 30 seconds.
  8. Set throttle to FULL.

*NOTE: In the event of an emergency the engine can be stopped by simply turning the ignition switch to STOP. Use this method only in emergency situations. For normal engine shut down follow the procedure given in STOPPING THE TRACTOR.*

# Operating the Tractor

## Stopping The Tractor & Engine

1. Return the ground speed control(s) to neutral.
2. Disengage the PTO and wait for all moving parts to stop.
3. **Briggs & Stratton Models:** Move the throttle control to SLOW position and turn the ignition key to OFF. Remove the key.

**Kohler Models:** Move the throttle control to FAST position and turn the ignition key to OFF. Remove the key.

## Driving The Tractor

1. Sit in the seat and adjust the seat so that you can comfortably reach all the controls and see the dashboard display.
2. Engage the parking brake.
3. Make sure the PTO switch is disengaged.
4. Start the engine (see STARTING THE ENGINE).
5. Disengage the parking brake and release the brake pedal.
6. Depress the forward ground speed control pedal to travel forward. Release the pedal to stop. Note that the further down the pedal is depressed the faster the tractor will travel.
7. Stop the tractor by releasing the ground speed control pedals, setting the parking brake, and stopping the engine (see STOPPING THE TRACTOR AND ENGINE).

## Mowing

1. Set the mower cutting height to the desired level and set the gauge wheels to the appropriate position (if equipped).
2. Engage the parking brake. Make sure the PTO switch is disengaged.
3. Start the engine (see STARTING THE ENGINE).
4. Fully lower the mower using the attachment lift lever and set cutting height.
5. Set the throttle to FULL.
6. Engage the PTO (Mower Deck).
7. Begin mowing. See Section LC for tips on mowing patterns, lawn care, and troubleshooting information.
8. When finished, shut off the PTO and raise the mower using the attachment lift control lever.
9. Stop the engine (see STOPPING THE TRACTOR AND ENGINE).

## ⚠ WARNING

The engine will shut off if the reverse ground speed pedal is depressed while the PTO is on and the RMO has not been activated. The operator should always turn the PTO off prior to driving across on roads, paths or any area that maybe used by other vehicles. Sudden loss of drive could create a hazard.

## ⚠ WARNING

Mowing in reverse can be hazardous to bystanders. Tragic accidents can occur if the operator is not alert to the presence of children. Never activate RMO if children are present. Children are often attracted to the unit and the mowing activity.

## Mowing in Reverse

If an operator chooses to mow in reverse, the RMO system can be used. To use the Reverse Mowing Option (RMO) turn the RMO key after the PTO is engaged. The L.E.D. light will illuminate, and the operator can then mow in reverse. Each time the PTO is engaged the RMO needs to be reactivated if desired. The key should be removed to restrict access to the RMO feature.

## Attachment Operation in Reverse

If an operator chooses to operate a PTO driven attachment in reverse, the RMO system can be used. To use the Reverse Mowing Option (RMO) turn the RMO key after the PTO is engaged. The L.E.D. light will illuminate, and the operator can then operate the attachment in reverse. Each time the PTO is disengaged the RMO needs to be reactivated if desired. The key should be removed to restrict access to the RMO feature.

## Pushing the Tractor by Hand

1. Disengage the PTO and turn the engine off.
2. Pull the transmission release (B, Figure 3) back approximately 2-3/8" (6 cm) to lock into released position.
3. The tractor can now be pushed by hand.



### DO NOT TOW TRACTOR

Towing the unit will cause transmission damage. • Do not use another vehicle to push or pull this unit. • Do not actuate the transmission release valve lever while the engine is running.

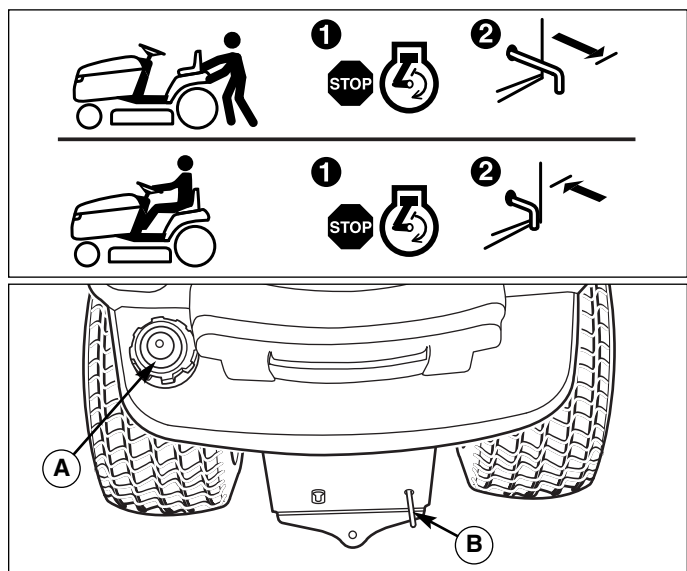

Figure 3. Transmission Release Lever & Fuel Tank  
A. Fuel Tank Cap.  
B. Transmission Release Lever



## Mower Deck Removal & Installation

### **⚠ WARNING**

Engage parking brake, disengage PTO, stop engine and remove key before attempting to install or remove the mower.

### Removing the Mower Deck

1. Park tractor on a hard, level surface such as a concrete floor. Turn off PTO switch and engine, remove the key and apply parking brake.
2. Place wood blocks under the mower deck. Place the attachment lift in the lowest position.

### **⚠ CAUTION**

**Stored energy device. 44" & 50" mowers have spring lift assist. Lift lever must be in lowest cutting position and mower on support blocks to avoid injury when removing or installing mower mounting hardware. Return lift lever to highest position after hardware has been disconnected.**

3. Move idler arm (A, Figure 5) to relieve belt tension. Remove belt from PTO pulley (B).
4. Remove hair pin (D, Figure 4) and washer (C). Disconnect the mower lift plates (A) from the tractor lift arms (B). Re-install washers (C) and hair pins (D) to prevent loss.
5. Return lift lever to highest position.

### **⚠ CAUTION**

**The muffler and surrounding areas may be hot.**

6. Turn wheels straight ahead. Support the mower hanger (C). Remove safety clip (A, Figure 6) and rod (B). Lower the mower hanger (C).
7. Turn wheels fully left, and slide mower deck out right side of tractor.

### Installing the Mower Deck

1. Park tractor, shut off PTO and engine, remove the key and apply parking brake. Turn the wheels fully to the left.
2. Place the mower lift lever (A, Figures 7) in the lowest position. Slide mower deck under right side of tractor so that mower hitch is aligned with the front tractor hitch.
3. Turn wheels straight. Lift the mower hanger (C, Figure 6). Insert rod (B) through mower hanger (C) and tractor brackets (D). Secure with safety clip (A).
4. Re-install hair pins (D, Figure 4) and washers (C) into the mower lift plates (A) and the tractor lift arms (B).
5. Move idler arm (A, Figure 5) to relieve belt tension. Install belt onto the PTO pulley (B).

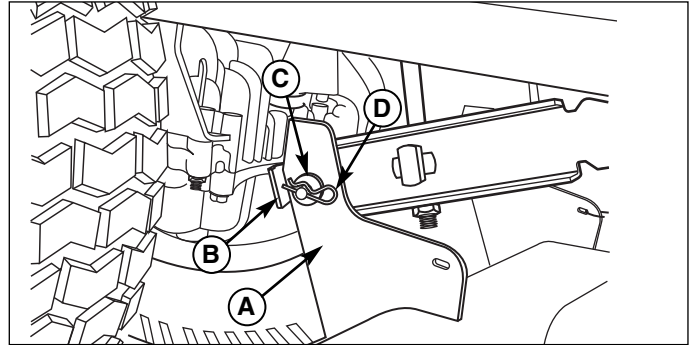

**Figure 4. Lift Arms (Viewed from underneath right side of tractor)**

- A. Mower Lift Plate**
- B. Tractor Lift Arm**
- C. Washer**
- D. Hair Pin**

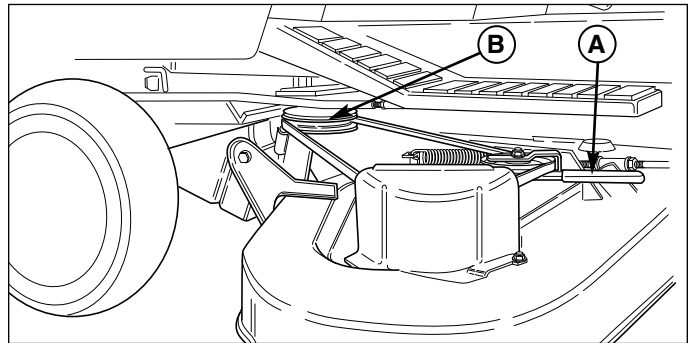

**Figure 5. Removing & Installing Belt**

- A. Idler Arm**
- B. PTO Pulley**

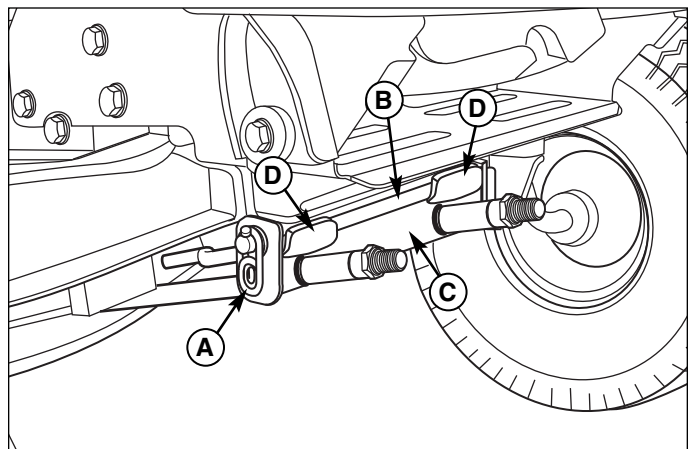

**Figure 6. Mower Hitch**

- A. Safety Clip**
- B. Rod**
- C. Mower Hanger**
- D. Tractor Brackets**

# Operating the Tractor

## Adjusting Mower Cutting Height

The cutting height lift lever (A, Figure 7) controls the mower cutting height. The cutting height is has seven positions between approximately 1-1/4" and 4" (3,2-10 cm).

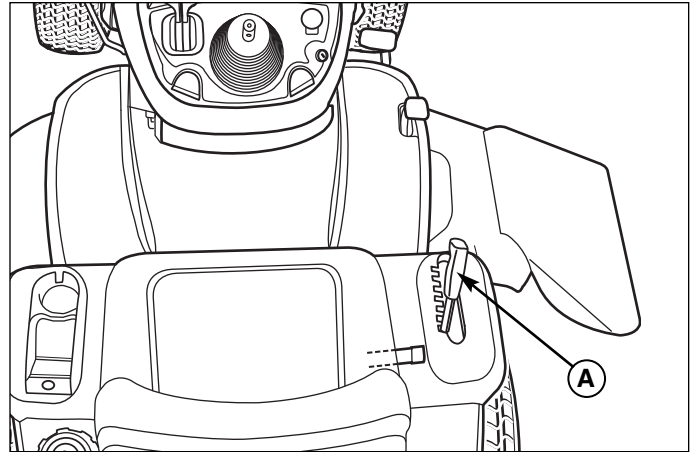

**Figure 7. Raising & Lowering Mower**  
**A. Mower Lift Lever**

## Attaching a Trailer

The maximum horizontal drawbar force allowed is 280 Newton. The maximum vertical drawbar force is 160 Newton. This equates to a 250 lbs (113 kg) trailer on a 10 degree hill. Secure the trailer with an appropriately sized clevis pin (A, Figure 8) and clip (B).

### **! WARNING**

**Never store the unit (with fuel) in an enclosed, poorly ventilated structure. Fuel vapors can travel to an ignition source (such as a furnace, water heater, etc.) and cause an explosion.**

**Fuel vapor is also toxic to humans and animals.**

## Storage

Before you store your unit for the off-season, read the Maintenance and Storage instructions in the Safety Rules section, then perform the following steps:

- Disengage the PTO, set the parking brake, & remove the key.
- Perform engine maintenance and storage measures listed in the engine owner's manual. This includes draining the fuel system, or adding stabilizer to the fuel (do not store a fueled unit in an enclosed structure - see warning).
- Battery life will be increased if it is removed, put in a cool, dry place and fully charged about once a month. If the battery is left in the unit, disconnect the negative cable.

Before starting the unit after it has been stored:

- Check all fluid levels. Check all maintenance items.
- Perform all recommended checks and procedures found in the engine owner's manual.
- Allow the engine to warm up for several minutes before use.

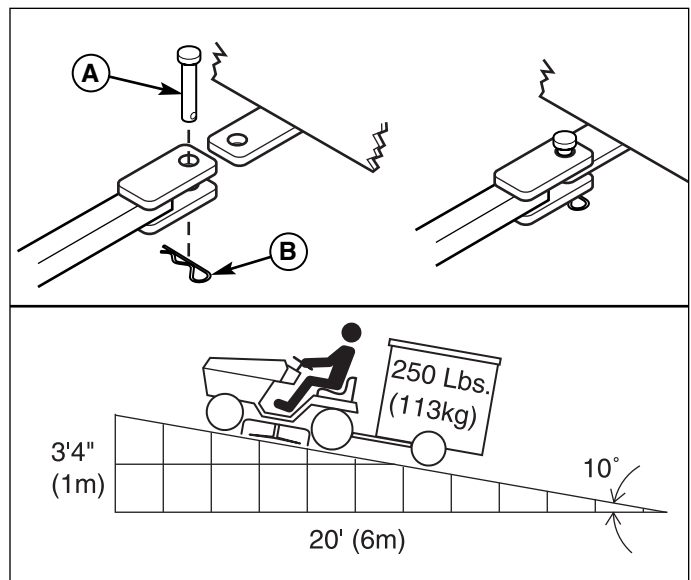

**Figure 8. Trailer Weight Recommendations**  
**A. Clevis Pin**  
**B. Clip**



# Regular Maintenance

## MAINTENANCE SCHEDULE & PROCEDURES

The following schedule should be followed for normal care of your tractor and mower.

<b>SAFETY ITEMS</b>	<b>Before Each Use</b>	<b>Every 5 Hours</b>	<b>Every 25 Hours</b>	<b>Every 100 Hours</b>	<b>Every 250 Hours</b>	<b>Spring &amp; Fall</b>
Check Safety Interlock System						●
Check Tractor Brakes						●
Check Mower Blade Stopping Time				●		●
<b>TRACTOR MAINTENANCE ITEMS</b>	<b>Before Each Use</b>	<b>Every 5 Hours</b>	<b>Every 25 Hours</b>	<b>Every 100 Hours</b>	<b>Every 250 Hours</b>	<b>Spring &amp; Fall</b>
Check Tractor/Mower for loose hardware		●				
Check / Clean Cooling Fins (If Equipped)				●		
Check / Adjust PTO Clutch					●	
Lubricate Tractor & Mower **			●			
Lubricate Rear Axle Shafts						Yearly
Clean Battery & Cables				●		
Check Tire Pressure			●			
Clean Deck & Check/Replace Mower Blades**				●		
<b>ENGINE MAINTENANCE ITEMS</b>	<b>Before Each Use</b>	<b>Every 5 Hours</b>	<b>Every 25 Hours</b>	<b>Every 50 Hours</b>	<b>Every 100 Hours</b>	<b>Spring &amp; Fall</b>
Check Engine Oil Level	●					
Check / Change Engine Air Filter *			●			
Change Engine Oil *				●	●	●
Change Engine Oil & Filter *					●	
Inspect Spark Plug(s) *						●
Check / Replace Fuel Filter *						

● = All Models

\* Refer to engine owner's manual. Change original engine oil after initial break-in period.

\*\* More often in hot (over 85° F: 30° C) weather or dusty operating conditions.

## Check Tire Pressures

### Service Interval: Every 25 Hours

Tire Pressure should be checked periodically, and maintained at the levels shown in the chart. Note that these pressures may differ slightly from the "Max Inflation" stamped on the side-wall of the tires. The pressures shown provide proper traction, improve cut quality, and extend tire life.

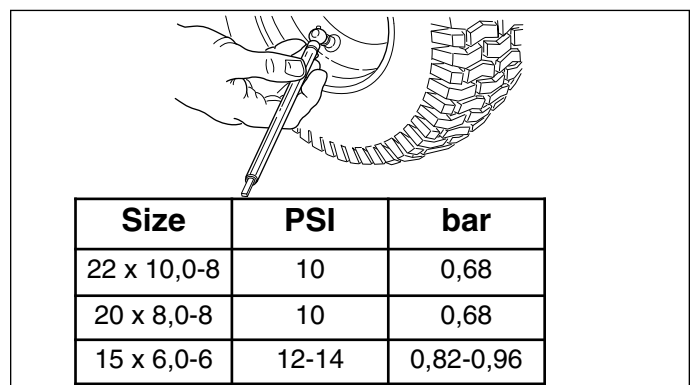

Figure 9. Tire Pressure

# Regular Maintenance

## Safety Interlock System Check

### Service Interval: Every Fall & Spring

Check the function of the safety interlock system using the test procedure found on page 13 of this manual. If the tractor fails any of the tests, see your dealer.

## Blade Brake Check

### Service Interval: Every 100 Hours or Fall & Spring

Mower blades and mower drive belt should come to a complete stop within five seconds after the electric PTO switch is turned off.

1. With tractor in neutral, PTO disengaged and operator in seat, start the engine.
2. Look over the left-hand footrest at the mower drive belt. Engage the PTO and wait several seconds. Disengage the PTO and check the amount of time it takes for the mower drive belt to stop.
3. If mower drive belt does not stop within five seconds, re-adjust the clutch or see your dealer.

## PTO Clutch Adjustment Check

### Service Interval: Every 250 Hrs

Check the PTO clutch adjustment after every 250 hours of operation—or if the clutch starts slipping or will not engage. Check and adjust the clutch using the procedure outlined in the Adjustments section of this manual.

## Engine Maintenance

Refer to the engine owner's manual for all engine maintenance procedures and recommendations.

## Battery Maintenance

### **!** WARNING

**When removing or installing battery cables, disconnect the negative cable FIRST and reconnect it LAST. If not done in this order, the positive terminal can be shorted to the frame by a tool.**

## Cleaning the Battery and Cables

### Service Interval: Every 100 Hours

1. Disconnect the cables from the battery, negative cables first (A, Figure 10) then the cover & positive cables (B).
2. Loosen the wingnut & washer (D).
3. Pivot the hold-down rod (C) up and away from battery. Secure to steering tower.
4. Remove the battery (E).
5. Clean the battery compartment with a solution of baking soda and water.
6. Clean the battery terminals and cable ends with a wire brush and battery terminal cleaner until shiny.
7. Reinstall the battery (E) in the battery compartment. Secure with the battery hold-down rod (C) and wingnut & washer (D).
8. Re-attach the battery cables, positive cables and cover first (B) then the negative cables (A).
9. Coat the cable ends and battery terminals with petroleum jelly or non-conducting grease.

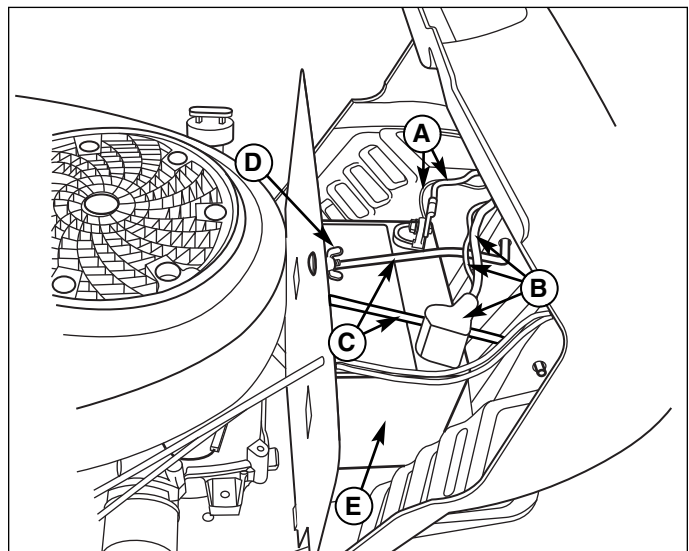

**Figure 10. Battery Maintenance**

- A. Negative Cables**
- B. Positive Cables & Cover**
- C. Hold-Down Rod**
- D. Wingnut & Washer**
- E. Battery**

## Transmission Identification

To determine what transmission is in your tractor, check the identification tag attached to the axle of the transmission (Figure 11), or check your tractor's parts book.

## Transmission Maintenance

### K46 Maintenance

The K46 is a sealed unit and does not require regular maintenance. If the transmission lacks drive or is excessively noisy, it may need to be purged. See your Dealer.

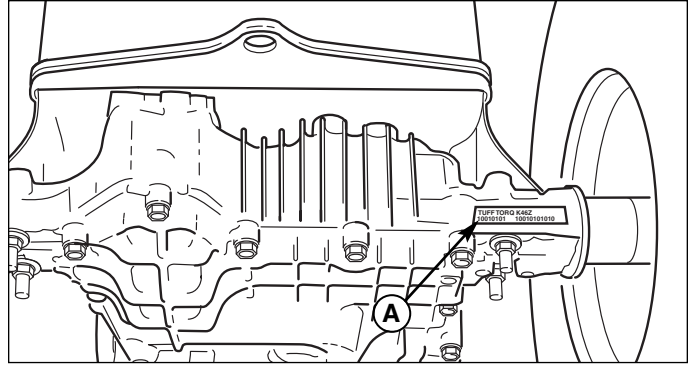

**Figure 11. Transmission ID Tag Location**  
A. ID Tag

## Hood Removal and Installation

### HOOD REMOVAL

1. Open the hood.
2. Remove the socket and bulbs (A, Figure 12) by twisting the socket counterclockwise and pulling it out of the bezel (B). Repeat on other side.
3. Rock the hood back slightly and lift hood (B, Figure 13) off pivot posts (C). Set hood on a clean and flat surface.

### HOOD INSTALLATION

1. Set hinge posts (A, Figure 13) onto pivot posts (C).
2. Roll the hood forward until it reaches the stops (D).
3. Install the socket and bulb (A) by pushing it into the bezel (B) twisting the socket and bulb clockwise. Repeat on other side.
4. Close the hood.

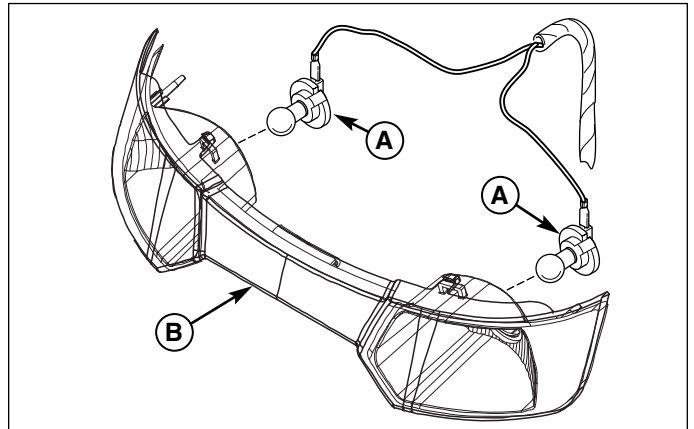

**Figure 12. Head Light**  
A. Socket and Bulb  
B. Bezel

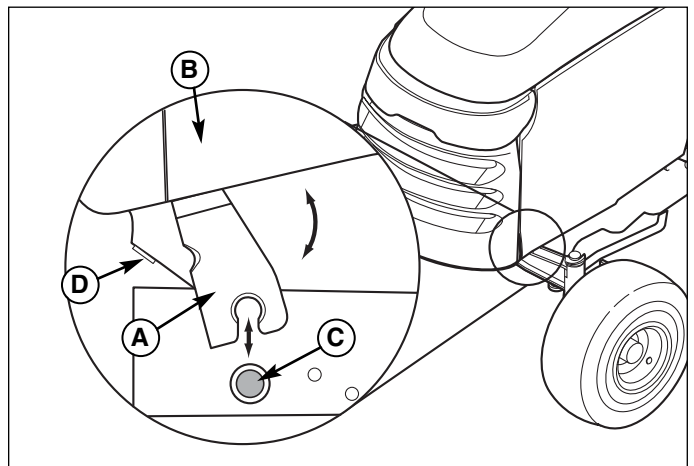

**Figure 13. Hood Removal and Installation**  
A. Hinge Post  
B. Hood  
C. Pivot Post  
D. Stop

# Regular Maintenance

## Lubrication

### Service Interval: Every 25 Hours

Lubricate the unit at the locations shown in Figures 14-16 as well as the lubrication points listed. Generally, all moving metal parts should be oiled where contact is made with other parts. Keep oil and grease off belts and pulleys. Wipe surfaces clean before and after lubrication.

#### Grease:



- steering linkage
- mower linkage
- rear axle shafts (remove wheel hubs)
- front axle pivot

#### Oil:



- foot pedal rods & brackets
- seat adjustment assembly
- draglink
- mower deck height adjustment linkage
- transmission idler assembly

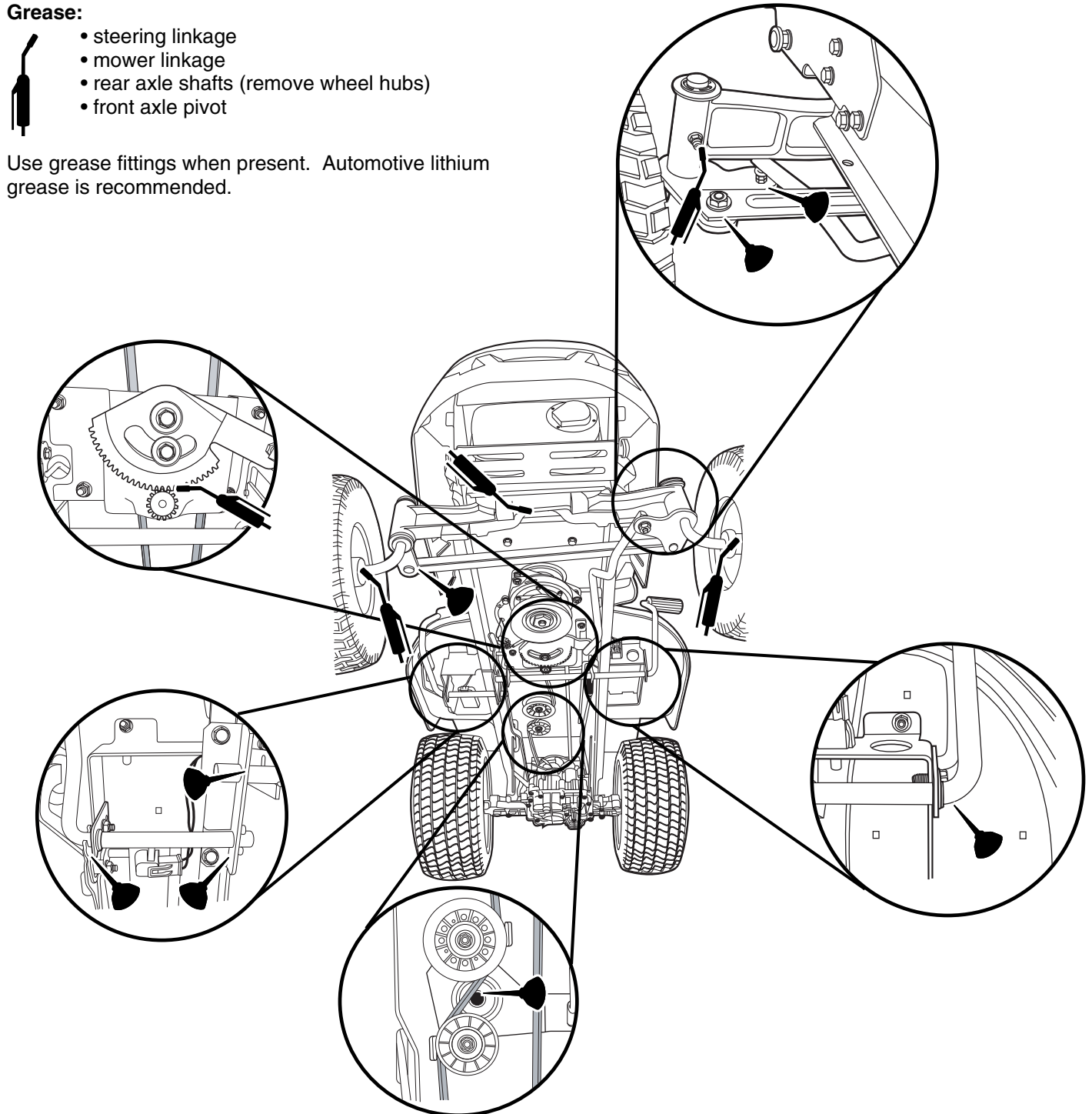

Figure 14. Lubricate Tractor

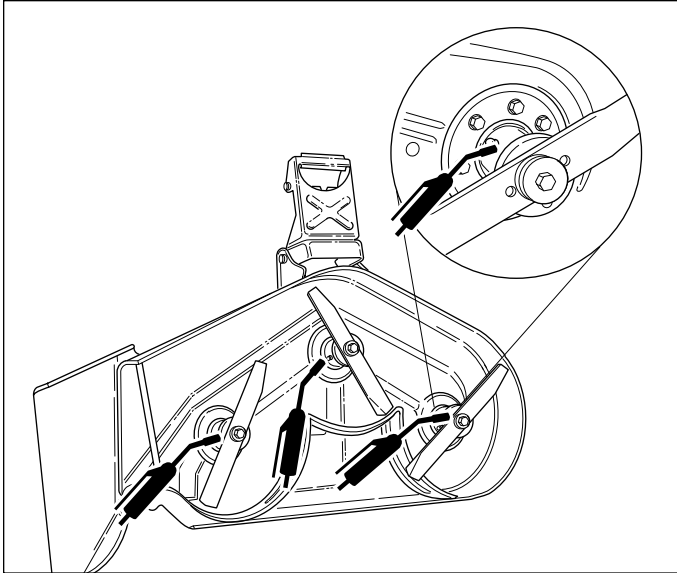

Figure 15. Arbor Lubrication Points

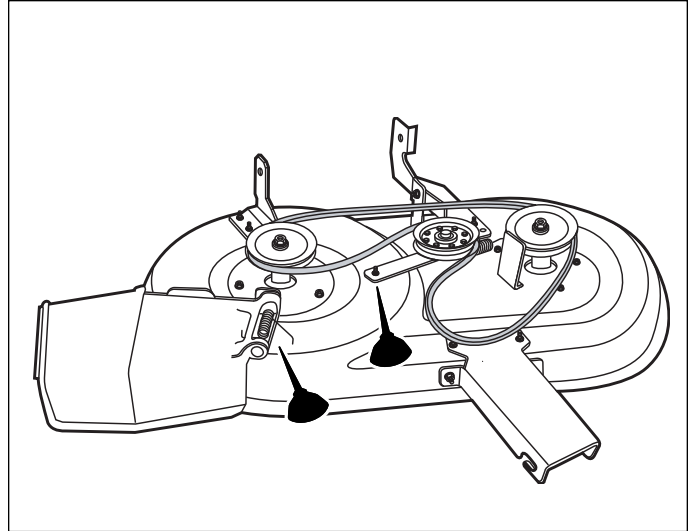

Figure 16. Lubricate Deck Linkage (38" shown)

## Lubricate Rear Axle Shafts

### Service Interval: Yearly

We recommend removing the rear wheel hubs and lubricating the axle shafts yearly. This prevents the wheel hubs from seizing onto the axle shaft and makes future service easier.

1. Turn off the ignition, turn off the PTO, engage the parking brake, and block the front tires.
2. Using a jack or chain hoist positioned at the center of the rear frame, carefully jack the unit up until the rear tires are approximately 1" - 2" (2.5-5cm) off the ground.

*NOTE: For overall unit stability during service, do not jack rear end higher than required for wheel removal.*

3. Support the rear of the unit on jackstands positioned under the rear frame.

*NOTE: Your axle assembly may differ slightly from the assembly pictured: the quantity of washers is adjusted to allow a small amount of axle end-play.*

4. Remove the hardware retaining the wheel assembly to the axle and lubricate the axle shaft using anti-seize compound or lithium grease.
5. Reinstall the components in reverse order of disassembly and lower the unit. Be sure the key (A, Figure 17) is in place in the axle keyway.

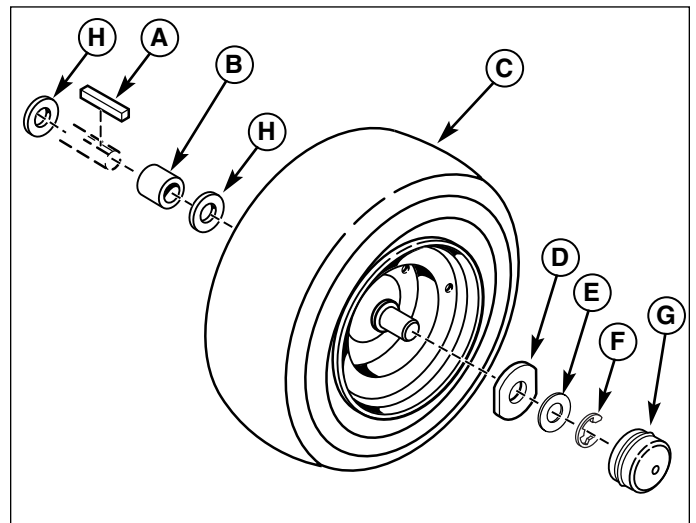

Figure 17. Rear Axle Hardware

- A. Key
- B. Spacer
- C. Wheel & Hub
- D. Special Washer
- E. Small Washer
- F. E-Clip
- G. Axle Cap
- H. Large Washer

## Regular Maintenance

### **⚠ WARNING**

For your personal safety, do not handle the sharp mower blades with bare hands. Careless or improper handling of blades may result in serious injury.

### **⚠ WARNING**

For your personal safety, blade mounting capscrews must each be installed with two spring washers or a hex washer and spring washer, then securely tightened. Torque blade mounting nut to 70 - 80 ft. lbs. (95 - 108 Nm). Torque blade mounting capscrew to 45 - 55 ft. lbs. (61 - 75 Nm).

## Servicing the Mower Blades

### Service Interval: Every 100 Hours or As Required

1. Remove mower deck (see "Mower Deck Removal").
2. See Figure 19. To remove blade for sharpening, use a block of wood to prevent blade rotation while loosening the capscrew.
3. Remove the nut (C, Figure 20), spring washers (B), and blade. Or remove the capscrew (D, Figure 21), hex washer (B), spring washer (C), and blade.
4. Use a file to sharpen blade to a fine edge. If blade is damaged, it must be replaced.
5. Balance the blade as shown in Figure 18. Center the blade's hole on a nail lubricated with a drop of oil. A balanced blade will remain level.
6. Reinstall the blade (Figures 21) with the tabs pointing up toward the mower deck as shown.
7. Reinstall the spring washers (B, Figure 20) and nut (C). Use a wooden block (A) to prevent blade rotation while tightening the nut (C) to 70-80 ft. lbs. (95-108 Nm). Or Reinstall the hex washer (B, Figure 21), spring washer (C) and capscrew (D). Use a wooden block (A) to prevent blade rotation while tightening the nut (D) to 45-55 ft. lbs. (61-75 Nm).

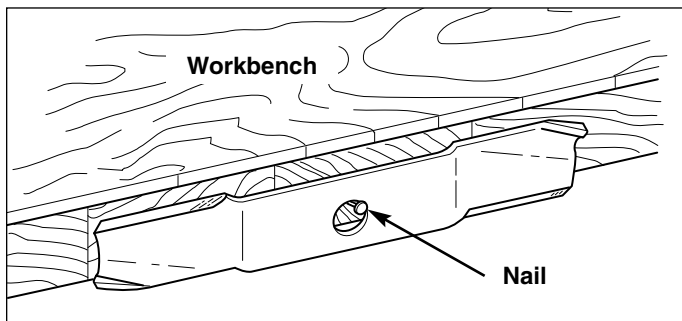

Figure 18. Balancing The Blade

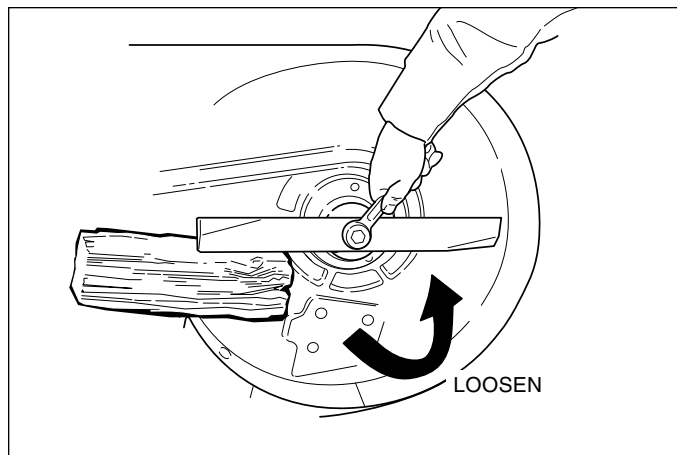

Figure 19. Blade Removal

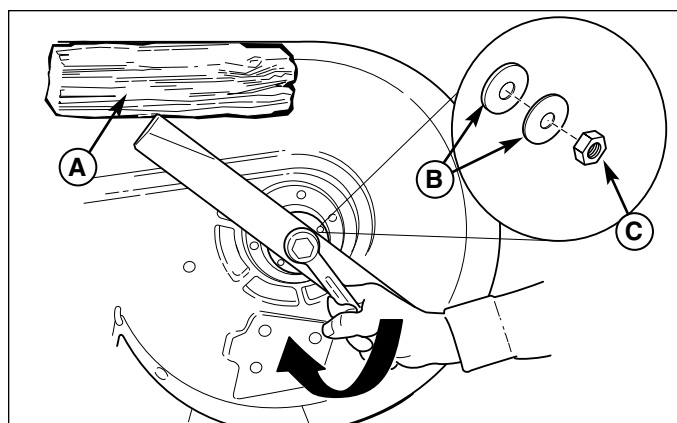

Figure 20. Blade Installation Mowers (38" & 40" Mowers)  
A. 4x4 Wood Block  
B. Spring Washers  
C. Blade Nut

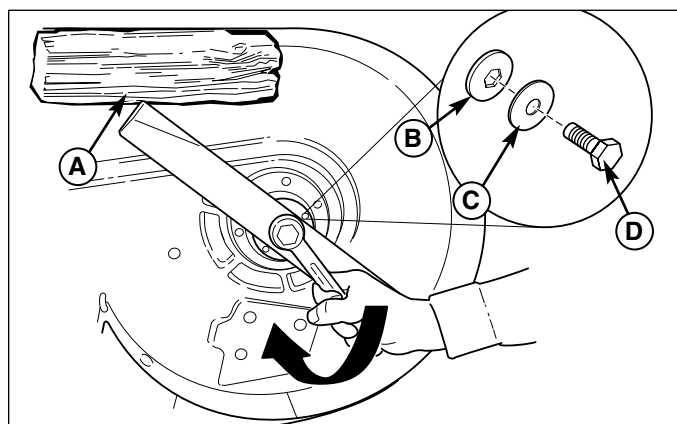

Figure 21. Blade Installation Mowers (44" Mowers)  
A. 4x4 Wood Block  
B. Hex Washer  
C. Spring Washer  
D. Blade Capscrew



## Check & Fill Engine Oil

**Service Interval:** Before each use, and every 8 hours.

1. Turn the engine off, and set the parking brake to PARK.
2. Clean the area around the dip stick (C, Figure 22 or 23).
3. Remove the dip stick (C) and clean it with a paper towel.
4. Insert the dip stick (C) back into the engine and thread the cap back onto the tube.
5. Remove the dip stick and read the oil level. The oil level should be between the "FULL" and "ADD" marks (D). If not, add oil according to the oil recommendations chart (Figure 25).

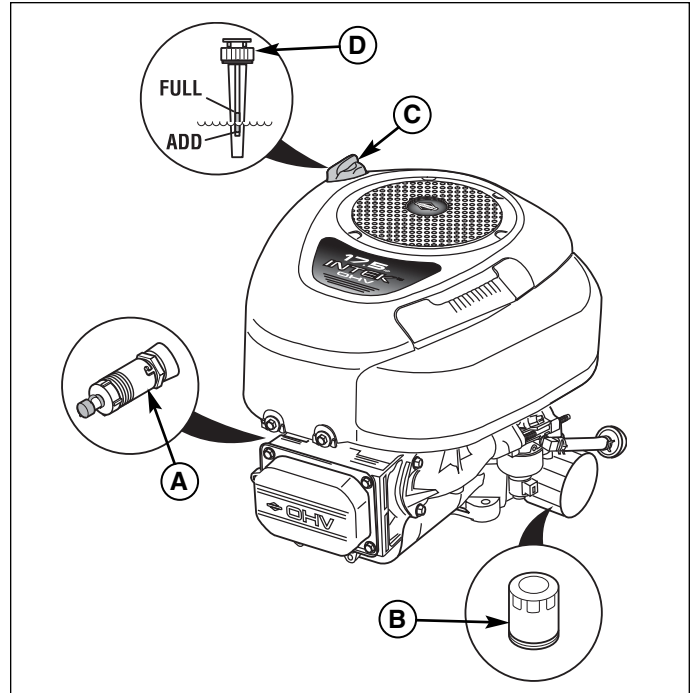

**Figure 22. Briggs & Stratton single cylinder Models**

- A. Oil Drain Valve
- B. Oil Filter
- C. Dip Stick
- D. Checking Oil Level

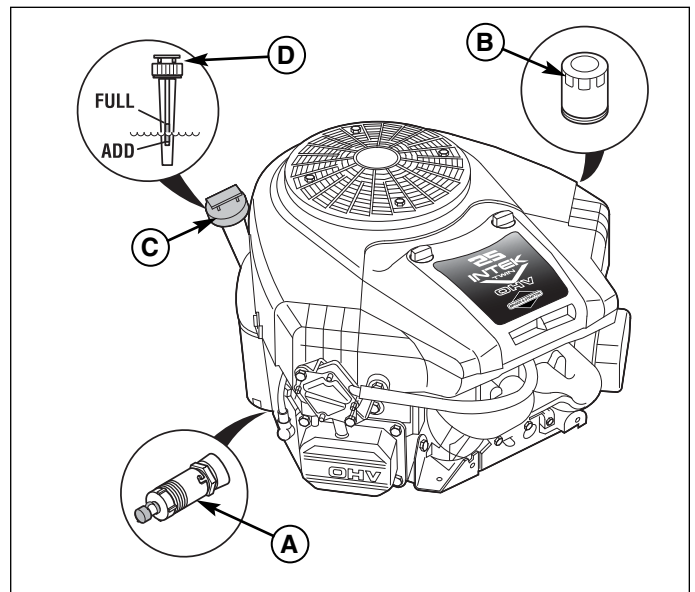

**Figure 23. Briggs & Stratton two cylinder Models**

- A. Oil Drain Valve
- B. Oil Filter
- C. Dip Stick
- D. Checking Oil Level

## Regular Maintenance

### Oil Drain Valve Operation

1. Place a suitable container with a 4 quart capacity under the oil drain valve (A, Figure 22 or 23).
2. Loosen or remove the dip stick (C, Figure 22 or 23).
3. Wipe oil drain valve (B, Figure 24) and cover (C) with paper towel or rag.

**NOTE:** Sliding a hose with a 1/2" (12.5 mm) inside diameter tube over the valve nipple may aid in guiding the draining oil.

4. Rotate the drain valve (B) counter clockwise and pull out 1/4" (6.35 mm) for engine oil to drain. Allow ample time for complete drainage.
5. After all the oil has drained, close the oil drain valve (B) by pushing in and rotating clockwise to close.
6. Wipe the nipple (D) with paper towel or rag. Install the cover (C) over nipple (D).

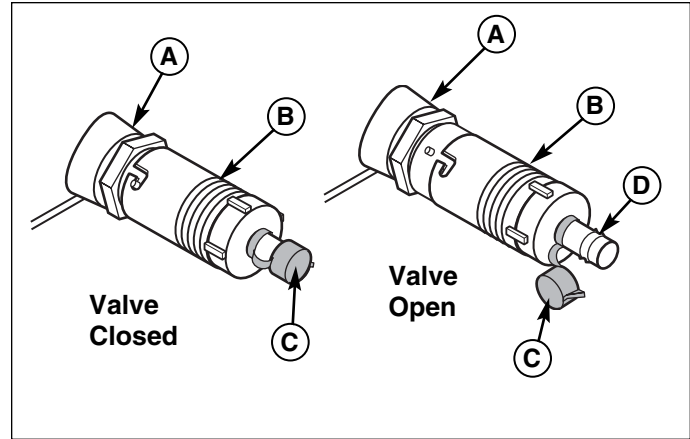

**Figure 24. Oil Drain Valve**  
**A. Engine Block / Valve Base**  
**B. Oil Drain Valve**  
**C. Cover**  
**D. Nipple**

### Change Engine Oil

#### BRIGGS & STRATTON MODELS

**Service Interval:** 50 hours or once per season.

**Oil Capacity:** Approximately 1-7/8 quarts (1.8L) without filter change.

**NOTE:** Change engine oil while the engine is warm. Run the engine for a few minutes, then shut the engine off and allow it to cool from hot to warm.

1. Clean the area around the dip stick (C, Figure 22 or 23) and oil drain valve (A).
2. Drain engine oil. See OIL DRAIN VALVE OPERATION above.
3. Fill the crankcase with oil. See CHECK ENGINE OIL LEVEL.

### Change Engine Oil & Filter

#### BRIGGS & STRATTON MODELS

**Service Interval:** 100 hours or once per season.

**Oil Capacity:** Approximately 2 quarts (1.9L) with oil filter change.

**NOTE:** Change engine oil while the engine is warm. Run the engine for a few minutes, then shut the engine off and allow it to cool from hot to warm.

1. Clean the area around the dip stick (C, Figure 22 or 23) and oil drain valve (A).
2. Drain engine oil. See OIL DRAIN VALVE OPERATION above.
3. Remove the oil filter (B). Discard the filter.
4. Using a drop of oil on your finger tip, wet the rubber gasket on the bottom of the new filter.

Use oil classified API Service Class SF, SG, SH, SJ or better with SAE Viscosity:

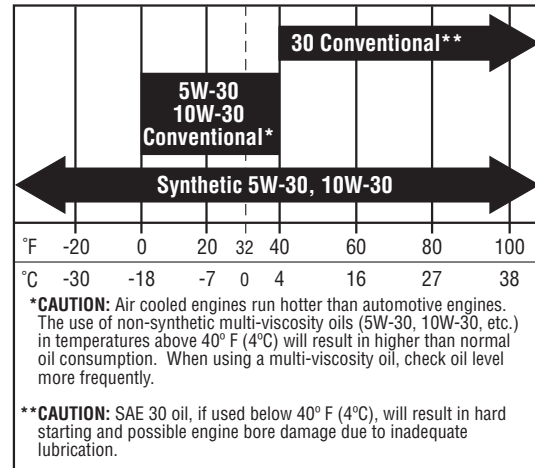

**Figure 25. Recommended Engine Oil - Briggs & Stratton Models**

5. Turn the filter clockwise until the rubber gasket meets the filter base. Then turn 1/2 to 3/4 turn more.
6. Fill the crankcase with oil. See CHECK ENGINE OIL LEVEL.
7. Test run the engine to check for leaks. Stop the engine for 1 minute, then recheck the oil level.

## Air Filter & Pre-Cleaner Service

### BRIGGS & STRATTON TWO CYLINDER MODELS

**Service Interval:** Pre-Cleaner: Every 25 hours or as required. Air Filter: Every 50 hours or as required.

**Replacement Interval:** Pre-Cleaner: As required. Air Filter: Every 200 hours or once per season.

### Air Filter Removal & Installation

1. Unscrew the four knobs (A, Figure 26) by turning counter clockwise.
2. Remove the cover (B). Remove the filter (C) and pre-cleaner (D).
3. Install the pre-cleaner (D) with the mesh side up. Install the filter (C) as shown.
4. Install the cover (B) making sure the tabs are inserted into their slots. Secure by turning screws clockwise until snug.

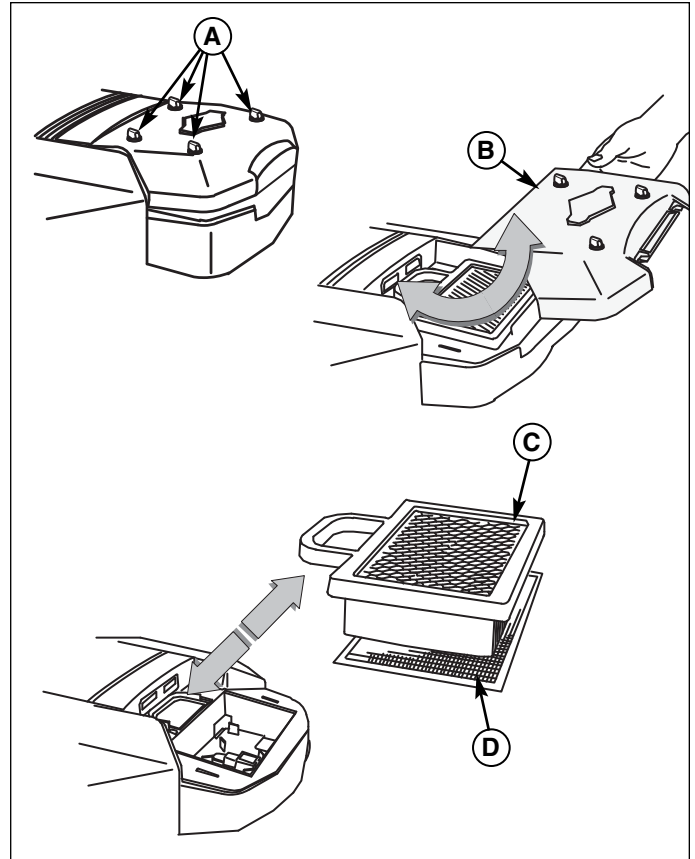

**Figure 26. Air Filter Assembly - Briggs & Stratton Twin Cylinder Models**

- A. Knobs
- B. Air Filter Cover
- C. Air Filter
- D. Pre-Cleaner

### Pre-Cleaner Service

*NOTE: Replace a worn or damaged pre-cleaner.*

1. Figure 27. Wash the pre-cleaner in liquid detergent and water.
2. Squeeze the pre-cleaner dry and saturate with engine oil. Remove all excess oil by squeezing the pre-cleaner in an absorbent cloth.

### Air Filter Service

*NOTE: Replace a worn or damaged air filter.*

1. Figure 27. If stamped "Washable," the filter can be washed with warm water and mild soap.
2. Rinse with tap water with the screen side UP allowing dirt and debris to filter out.
3. Allow the filter to dry overnight before reinstalling.

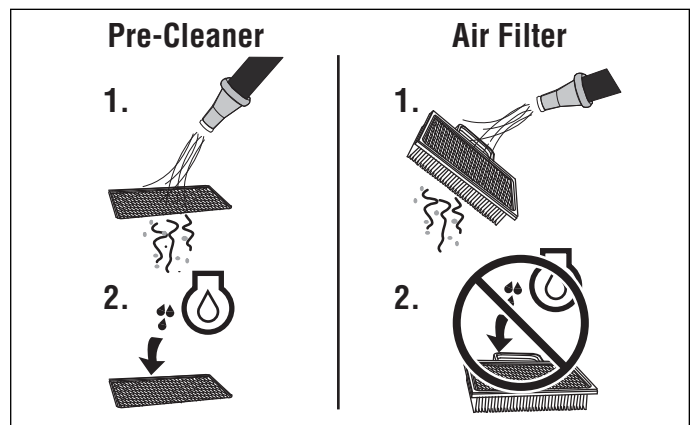

**Figure 27. Air Filter Service**

# Regular Maintenance

## Air Filter & Pre-Cleaner Service

### BRIGGS & STRATTON SINGLE CYLINDER MODELS

**Service Interval:** Pre-Cleaner: Every 25 hours or as required. Air Filter: Every 50 hours or as required.

**Replacement Interval:** Pre-Cleaner: As required. Air Filter: Every 200 hours or once per season.

### Air Filter Removal & Installation

1. Lift up on the air filter latch (A, Figure 29).
2. Rotate the air filter latch (A) to the inside.
3. Pull air filter cover (B) out and off.
4. Lift air cleaner (C, Figure 30) and pre cleaner (D) if equipped, from blower housing)
5. Install the pre-cleaner (D) with the mesh side up. Install the filter (C) as shown.
6. Install the cover (B) making sure the tabs are inserted into their slots. Secure with the latch (A).

### Pre-Cleaner Service

*NOTE: Replace a worn or damaged pre-cleaner.*

1. Figure 28. Wash the pre-cleaner in liquid detergent and water.
2. Squeeze the pre-cleaner dry. **Do not oil pre-cleaner.**

### Air Filter Service

*NOTE: Replace a worn or damaged air filter.*

1. Figure 28. If stamped "Washable," the filter can be washed with warm water and mild soap.
2. Rinse with tap water with the screen side UP allowing dirt and debris to filter out.
3. Allow the filter to dry overnight before reinstalling.

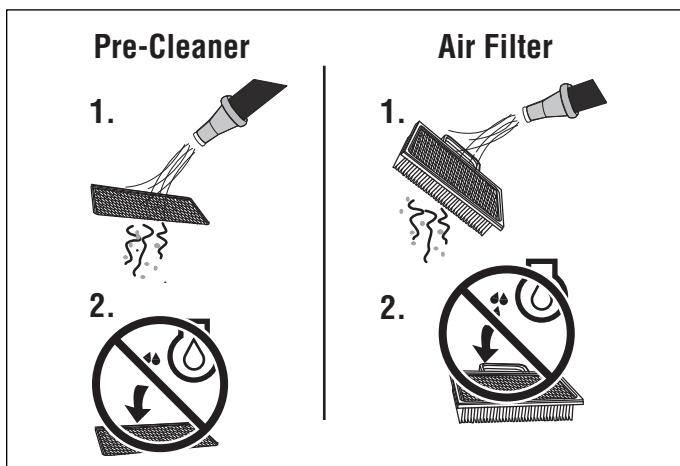

Figure 28. Air Filter Service

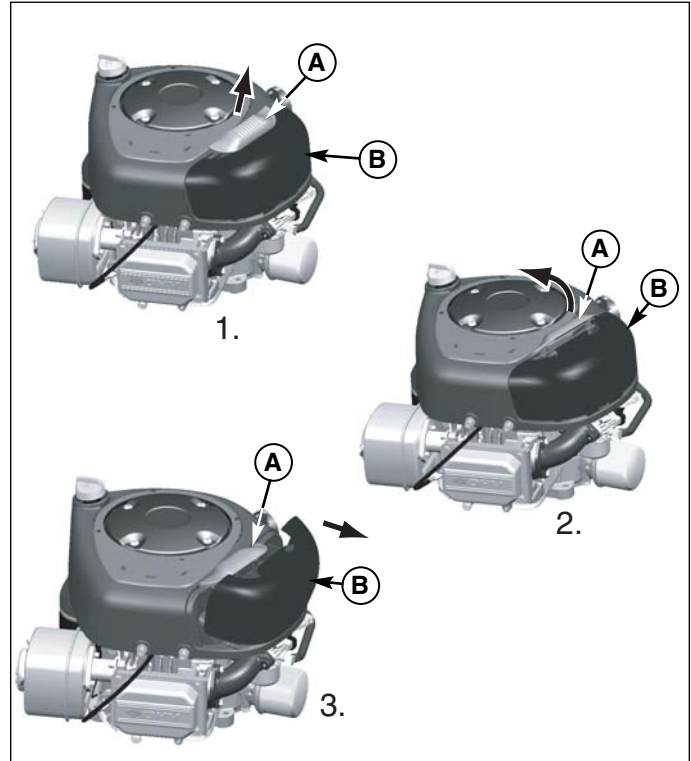

Figure 29. Air Filter Assembly - Briggs & Stratton Single Cylinder Models  
A. Air Filter Latch  
B. Air Filter Cover

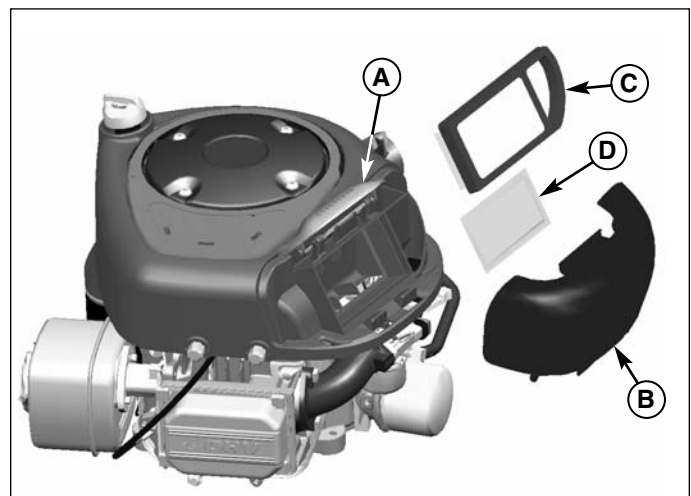

Figure 30. Air Filter Service - Briggs & Stratton Single Cylinder Models  
A. Air Filter Latch  
B. Air Filter Cover  
C. Air Filter  
D. Pre-Cleaner

## Replace Spark Plug

**Service Interval:** Yearly

**Spark Plug Gap:** .030" (.76mm)

### Replacement Spark Plug

Resistor Spark Plug, Champion RC12YC

1. Stop the engine and allow it to cool.
2. See Figures 31 or 32. Clean the area around the spark plug.
3. Remove the spark plug.
4. Check the spark plug gap. It should be .030" (see Figure 31 or 32).
5. Reinstall the plug into the cylinder head. Torque the plug to 180 in. lbs (20 N.m.).

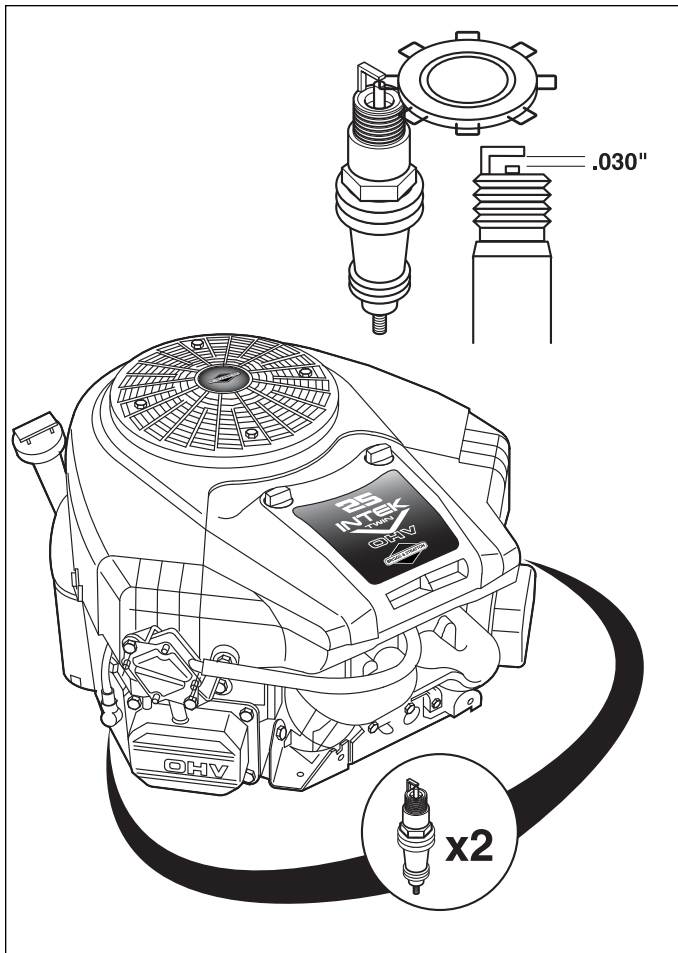

Figure 31. Spark Plug Gapping

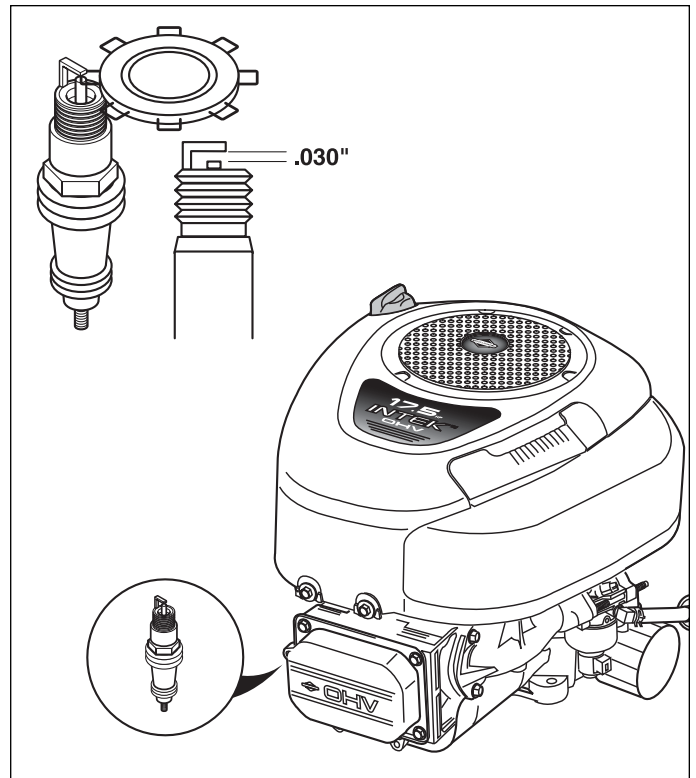

Figure 32. Spark Plug Gapping

# Troubleshooting, Adjustment, & Service



## Troubleshooting

While normal care and regular maintenance will extend the life of your equipment, prolonged or constant use may eventually require that service be performed to allow it to continue operating properly.

The troubleshooting guide below lists the most common problems, their causes, and remedies.

See the information on the following pages for instructions on how to perform most of these minor adjustments and service repairs yourself. If you prefer, all of these procedures can be performed for you by your local authorized dealer.

## WARNING

**To avoid serious injury, perform maintenance on the tractor or mower only when the engine is stopped and the parking brake engaged.**

**Always remove the ignition key, disconnect the spark plug wire and fasten it away from the plug before beginning the maintenance, to prevent accidental starting of the engine.**

## Troubleshooting the Tractor

PROBLEM	CAUSE	REMEDY
<b>Engine will not turnover or start.</b>	<ol style="list-style-type: none"> <li>1. Brake pedal not depressed.</li> <li>2. PTO (electric clutch) switch in ON position.</li> <li>3. Cruise control engaged.</li> <li>4. Out of fuel.</li> <li>5. Engine flooded.</li> <li>6. Fuse Blown.</li> <li>7. Battery terminals require cleaning.</li> <li>8. Battery discharged or dead.</li> <li>9. Wiring loose or broken.</li> <li>10. Solenoid or starter motor faulty.</li> <li>11. Safety interlock switch faulty</li> <li>12. Spark plug(s) faulty, fouled or incorrectly gapped.</li> <li>13. Water in fuel.</li> <li>14. Gas is old or stale.</li> </ol>	<p>Fully depress brake pedal. Place in OFF position.</p> <p>Move knob to Neutral/Off position. If engine is hot, allow it to cool, then refill the fuel tank. Disengage choke. Replace. See Battery Maintenance Section.</p> <p>Recharge or replace. Visually check wiring &amp; replace broken or frayed wires. Tighten loose connections. See your dealer. See your dealer. Clean and gap or replace. See engine manual. Drain fuel &amp; refill with fresh fuel. Replace fuel filter. Drain fuel &amp; refill with fresh fuel. Replace fuel filter.</p>
<b>Engine starts hard or runs poorly.</b>	<ol style="list-style-type: none"> <li>1. Fuel mixture too rich.</li> <li>2. Spark plug(s) faulty, fouled, or incorrectly gapped.</li> </ol>	<p>Clean air filter. Check choke adjustment Clean and gap or replace. See engine manual.</p>
<b>Engine knocks.</b>	<ol style="list-style-type: none"> <li>1. Low oil level.</li> <li>2. Using wrong grade oil.</li> </ol>	<p>Check/add oil as required. See engine manual.</p>
<b>Excessive oil consumption.</b>	<ol style="list-style-type: none"> <li>1. Engine running too hot.</li> <li>2. Using wrong weight oil.</li> <li>3. Too much oil in crankcase.</li> </ol>	<p>Clean engine fins, blower screen and air cleaner. Clean radiator screen. See engine manual. Drain excess oil.</p>
<b>Engine exhaust is black.</b>	<ol style="list-style-type: none"> <li>1. Dirty air filter.</li> <li>2. Choke closed.</li> </ol>	<p>Replace air filter. See engine manual. Open choke.</p>
<b>Engine runs, but tractor will not drive.</b>	<ol style="list-style-type: none"> <li>1. Ground speed control pedals not depressed.</li> <li>2. Transmission release lever in "push" position.</li> <li>3. Drive belt is broken.</li> <li>4. Drive belt slips.</li> <li>5. Parking brake is engaged.</li> </ol>	<p>Depress pedals.</p> <p>Move into drive position.</p> <p>See Dealer. See cause and remedy below. Disengage parking brake.</p>

## Tractor Troubleshooting Cont.

<b>Tractor drive belt slips.</b>	<ol style="list-style-type: none"> <li>1. Pulleys or belt greasy or oily.</li> <li>2. Belt stretched or worn.</li> <li>3. Idler pulley pivot bracket "frozen" in declutched position.</li> </ol>	<p>Clean as required. See Dealer. Remove idler pulley bracket, clean and lubricate.</p>
<b>Brake will not hold.</b>	<ol style="list-style-type: none"> <li>1. Internal brake worn.</li> </ol>	See your dealer.
<b>Tractor steers hard or handles poorly.</b>	<ol style="list-style-type: none"> <li>1. Steering linkage is loose.</li> <li>2. Improper tire inflation.</li> <li>3. Front wheel spindle bearings dry.</li> </ol>	<p>Check and tighten any loose connections. See Steering Gear Adjustment. Check and correct. Grease spindles. See Lubricating the Tractor.</p>

## Troubleshooting the Mower

PROBLEM	CAUSE	REMEDY
<b>Mower will not raise.</b>	<ol style="list-style-type: none"> <li>1. Lift linkage not properly attached or damaged.</li> </ol>	Attach or repair.
<b>Mower cut is uneven.</b>	<ol style="list-style-type: none"> <li>1. Mower not leveled properly.</li> <li>2. Tractor tires not inflated equally or properly.</li> </ol>	<p>See Mower Adjustment. See Maintenance Section.</p>
<b>Mower cut is rough looking.</b>	<ol style="list-style-type: none"> <li>1. Engine speed too slow.</li> <li>2. Ground speed too fast.</li> <li>3. Blades are dull.</li> <li>4. Mower drive belt slipping because it is oily or worn.</li> <li>5. Check PTO (Electric Clutch) Adjustment.</li> <li>6. Blades not properly fastened to arbors.</li> </ol>	<p>Set to full throttle. Slow down. Sharpen or replace blades. See Mower Blade Service. Clean or replace belt as necessary.</p> <p>See Adjustments Section.</p> <p>See Servicing the Mower Blades.</p>
<b>Engine stalls easily with mower engaged.</b>	<ol style="list-style-type: none"> <li>1. Engine speed too slow.</li> <li>2. Ground speed too fast.</li> <li>3. Dirty or Clogged air filter.</li> <li>4. Cutting height set too low.</li> <li>5. Discharge chute jamming with cut grass.</li> <li>6. Engine not up to operating temperature.</li> <li>7. Starting mower in tall grass.</li> </ol>	<p>Set to full throttle. Slow down. See Engine Manual. Cut tall grass at maximum cutting height during first pass. Cut grass with discharge pointing toward previously cut area. Run engine for several minutes to warm-up.</p> <p>Start the mower in a cleared area.</p>
<b>Excessive mower vibration.</b>	<ol style="list-style-type: none"> <li>1. Blade mounting screws are loose.</li> <li>2. Mower blades, arbors, or pulleys are bent.</li> <li>3. Mower blades are out of balance.</li> <li>4. Belt installed incorrectly.</li> </ol>	<p>Tighten to 45-55 ft.lbs. (61-75 Nm).</p> <p>Check and replace as necessary.</p> <p>Remove, sharpen, and balance blades. See Servicing the Mower Blades. Reinstall Correctly.</p>
<b>Excessive belt wear or breakage.</b>	<ol style="list-style-type: none"> <li>1. Bent or rough pulleys.</li> <li>2. Using incorrect belt.</li> </ol>	<p>Repair or replace. Replace with correct belt.</p>
<b>Mower drive belt slips or fails to drive.</b>	<ol style="list-style-type: none"> <li>1. Idler pulley spring broken or not properly attached.</li> <li>2. Belt stops out of adjustment.</li> <li>3. Mower drive belt broken.</li> <li>4. PTO clutch out of adjustment.</li> </ol>	<p>Repair or replace as needed.</p> <p>Check belt stops. Replace drive belt. Adjust PTO clutch.</p>

# Troubleshooting, Adjustment, & Service

---

## Seat Adjustment

The seat can be adjusted forward and back. Move the lever (A, Figure 33), position the seat as desired, and release the lever to lock the seat into position.

## Battery Charging

### **WARNING**

**Keep open flames and sparks away from the battery; the gasses coming from it are highly explosive. Ventilate the battery well during charging.**

A dead battery or one too weak to start the engine may be the result of a defect in the charging system or other electrical component. If there is any doubt about the cause of the problem, see your dealer. If you need to replace the battery, follow the steps under Cleaning the Battery & Cables in the Regular Maintenance Section.

To charge the battery, follow the instructions provided by the battery charger manufacturer as well as all warnings included in the safety rules sections of this book. Charge the battery until fully charged. Do not charge at a rate higher than 10 amps.

## Brake Adjustment

This unit does not have a manually adjustable brake. If brake does not function properly see your dealer

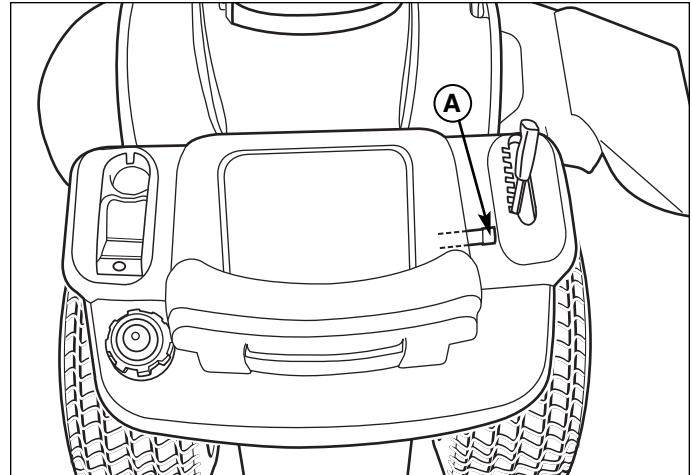

**Figure 33. Seat Adjustment**  
**A. Seat Adjustment Lever**



## PTO clutch adjustment

### **⚠ WARNING**

To avoid serious injury, perform adjustments only with engine stopped, key removed and tractor on level ground.

Check the PTO clutch adjustment after every 250 hours of operation. Also perform the following procedure if the clutch is slipping or will not engage, or if a new clutch has been installed.

1. Remove key from ignition switch and disconnect spark plug wires to prevent the possibility of accidental starting while the PTO is being adjusted.
2. See Figure 34. Note the position of the 3 adjustment windows (A) in the side of the brake plate and the nylock adjustment nuts (B).
3. Insert a .012"-.015" (2,5-4mm) feeler gauge (C) through each window, positioning the gauge between the rotor face and the armature face as shown in Figure 35.
4. Alternately tighten the adjustment nuts (B, Figure 34) until the rotor face and armature face just contacts the gauge.
5. Check the windows for an equal amount of tension when the gauge is inserted and removed, and make any necessary adjustments by tightening or loosening the adjustment nuts.

*NOTE: The actual air gap between the rotor and armature may vary even after performing the adjustment procedure. This is due to dimensional variations on component parts, and is an acceptable condition.*

6. Check the mower blade stopping time. The mower blades and mower drive belt should come to a complete stop within five seconds after the electric PTO switch is turned off.
7. Perform the BLADE BRAKE CHECK found in the MAINTENANCE Section. Mower blades and mower drive belt should come to a complete stop within five seconds after electric PTO switch is turned off.

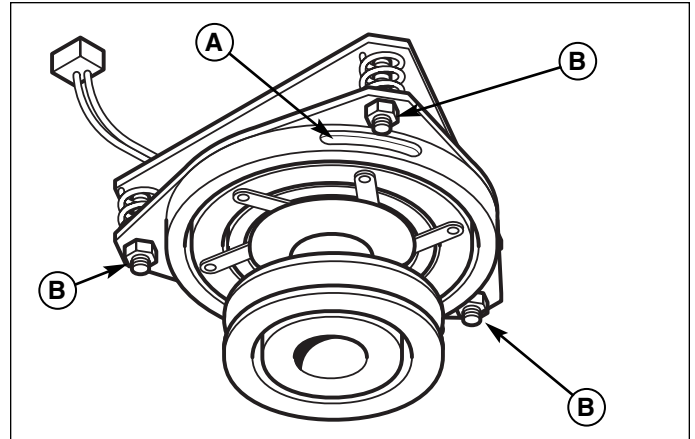

**Figure 34. PTO Clutch Adjustment**  
**A. Adjustment Window (Qty. 3, one shown)**  
**B. Adjustment Nut**

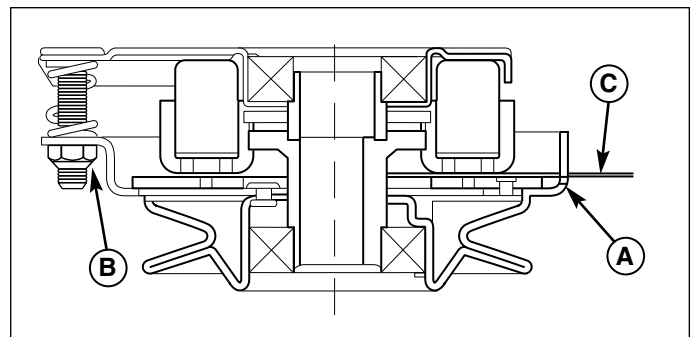

**Figure 35. Adjust PTO Clutch**  
**A. Window**  
**B. Adjustment Nut**  
**C. Feeler Gauge**

## Fuse Replacement

The fuse is a 20-amp blade type automotive fuse located behind the battery on the steering tower. **Replace only with the same rated fuse, 20-amp.**

To replace the fuse:

1. Open the hood and locate the fuse holder (B, Figure 36) and fuse (A). Attached to the steering tower.
2. Hold the fuse holder (B) and pull out the fuse (A).
3. Inspect the fuse for a broken fusible link. See figure 37. Replace fuse if connection is broken. If you are not sure if the fusible link is broken replace fuse.
4. Hold the fuse holder (B, Figure 36) and insert new fuse (A) until it is seated properly.

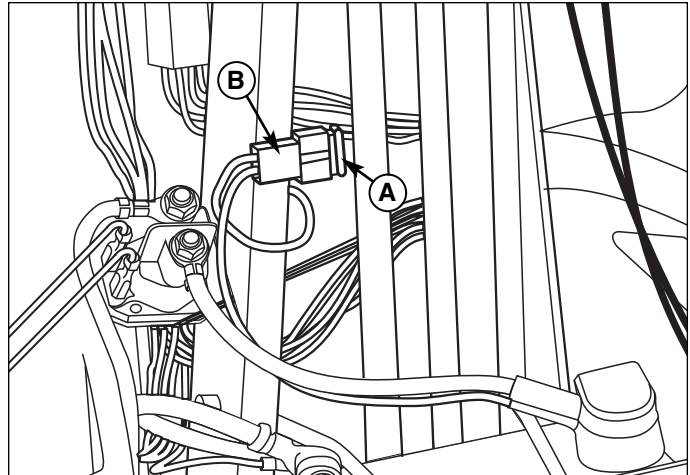

**Figure 36. Fuse**  
A. Fuse, 20-amp  
B. Fuse Holder

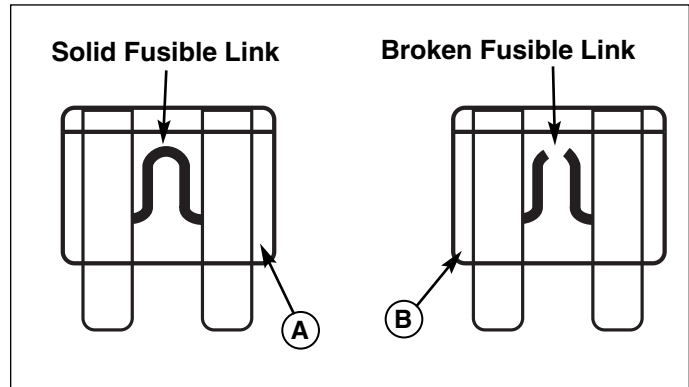

**Figure 37. Blade Type Fuse**  
A. Good Fuse with Solid Fusible link  
B. No Good Fuse with Broken Fusible link

## Mower Adjustments

### Gauge Wheels (Select Models)

The mower gauge wheels can be placed in two positions depending on the height of cut. When using higher cutting heights, set the wheels in the lower position. When using lower cutting heights, set the wheels in the upper position. Do not allow wheels to remain on the ground constantly while mowing. To adjust:

1. Remove the locknut (B, Figure 38), gauge wheel (C), washers (D), and shoulder bolt (E). Change position of gauge wheel to desired height.
2. Insert shoulder bolt (E) through washers (D) gauge wheel (C), and gauge wheel bracket (A). Secure with locknut (B). Repeat steps 1 & 2 for all gauge wheels.

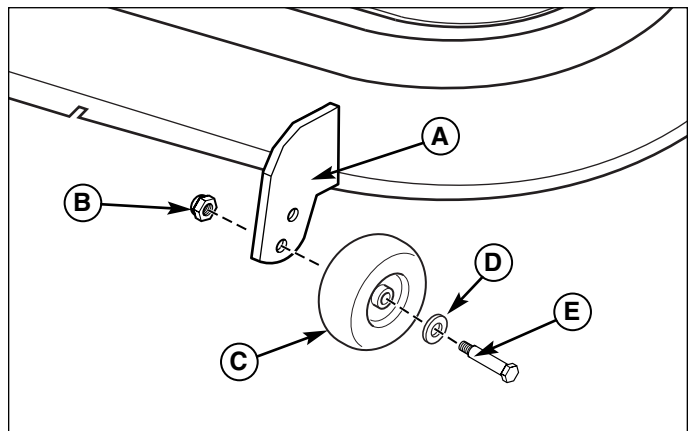

**Figure 38. Fixed Bracket Gauge Wheel Adjustment**  
A. Gauge Wheel Bracket  
B. Locknut  
C. Gauge Wheel  
D. Washer  
E. Shoulder Bolt

## WARNING

Before checking mower, shut off PTO and engine, remove the key, and allow all moving parts to stop.

## Leveling The Mower

If the cut is uneven, the mower may need leveling. Unequal or improper tire pressure may also cause an uneven cut. Make sure tire pressure is correct as specified in Checking Tire Pressure.

### SIDE-TO-SIDE LEVELING

1. With the mower installed, place the tractor on a smooth, level surface such as a concrete floor. Turn the front wheels straight forward.
2. Check for bent blades and replace if necessary.
3. Place the mower in mid-cut position. Arrange the outside mower blades so that they are pointing from side-to-side.
4. Measure the distance between the outside tips of each blade and the ground. If there is more than 1/8" (3mm) difference between the measurements on each side, proceed to step 5. If the difference is 1/8" (3mm) or less, proceed to step 6.
5. Turn the locknut (B, Figure 39) to raise or lower that side of the mower.

*Note: The maximum the mower can be adjusted in high cut is 3/8" to 1/2" between the frame and mower up-stop. See Figure 39.*

### FRONT-TO-BACK LEVELING

6. Arrange the blades so they face front-to-back.
7. Measure the distance from the ground to the front tip of the center blade, and from the ground to rear tips of left-hand and right-hand blades.

### 44" MOWER DECK -

Front tip of the center blade should be 1/4" (6mm) higher than rear tips of left-hand and right-hand blades. If not, proceed with step 8.

### 38" & 40" MOWER DECKS -

A front to back deck height variance of 1/8" (3mm) and side to side variance of 1/8" (3mm) is acceptable. If not, proceed with step 8.

8. To raise front of mower deck, tighten locknuts (A, Figure 40) and against spacers (B). To lower front of mower deck, loosen locknuts (A). Locknuts must be turned evenly on both sides to keep deck level.
9. Re-check the blade measurement then tighten the front nut (B) against the bracket to secure.

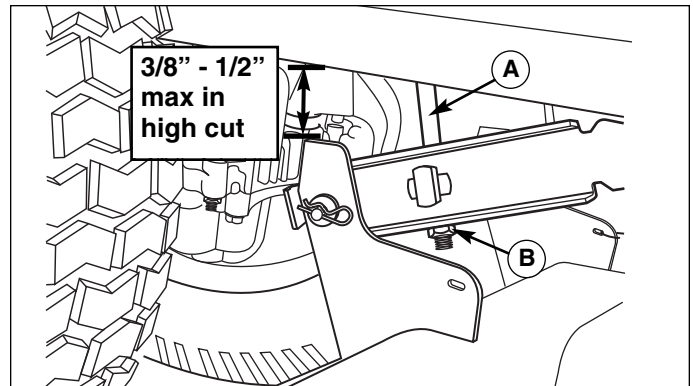

**Figure 39. Leveling The Mower Side-to-Side**

**A. Lift Rod**  
**B. Locknut**

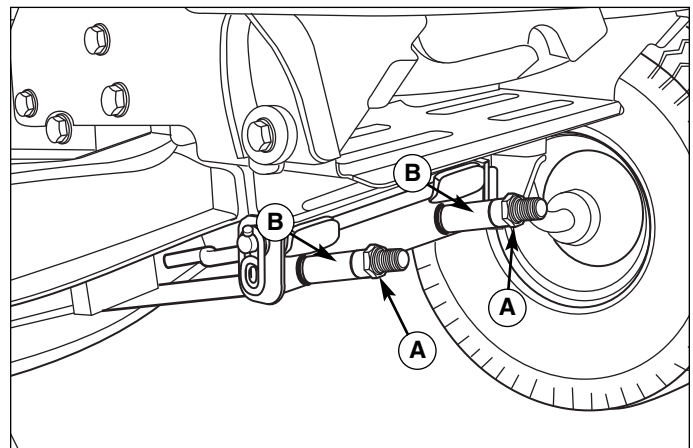

**Figure 40. Leveling The Mower Side-to-Side**

**A. Locknuts**  
**B. Spacers**

## Mower Belt Replacement

 To avoid damaging belts, DO NOT PRY BELTS OVER PULLEYS.

*Note: It is not necessary to remove the mower to install a new belt. However, for easier access mower can be removed. See Mower Removal in the Operation section.*

1. Park the tractor on a smooth, level surface such as a concrete floor. Disengage the PTO, turn off the engine and lock the parking brake. Remove the key.
2. If mower is not removed, lower the mower lift and place the mower in the lowest cutting position.
3. Push the idler arm (A, Figure 41 or 42) to relieve belt tension. Drop the belt from the PTO (electric clutch) pulley.

**IMPORTANT:** Note the position of all belt guides relative to the belt and pulleys before loosening.

4. Some Models. Loosen the belt stop bracket(s) (C).
5. Remove the old belt and replace with a new belt. Make sure V-side of belt runs in arbor pulley grooves and the flat backside runs against the idler pulley.
6. Some Models. Position the belt stop bracket(s) (C) in their original positions. There must be 1/8" clearance between the belt stop and the pulleys.
7. Position the idler pulley belt guide (D) in its original position up against arm (A) so that there is a 1/8" gap between the pulley and belt guide.
8. Install mower on tractor if it was removed. See Operation section.
9. Run the mower under no-load condition for about 5 minutes

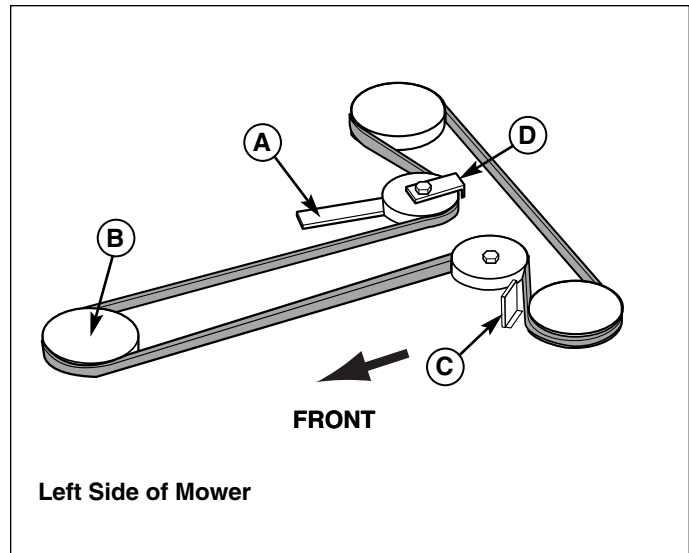

**Figure 41. Typical Mower Belt Routing Two Blade Decks**

- A. Idler Pulley Arm
- B. PTO Pulley (Engine)
- C. Mower Upstop
- D. Idler Pulley Belt Guide

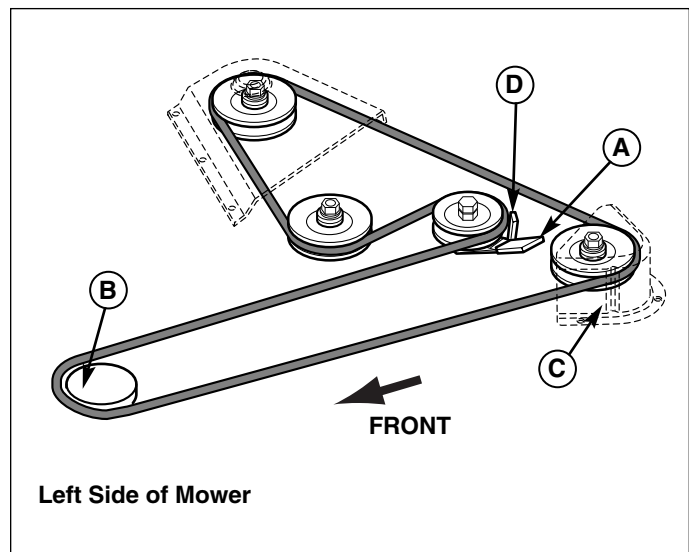

**Figure 42. Typical Mower Belt Routing Three Blade Decks**

- A. Idler Pulley Arm
- B. PTO Pulley (Engine)
- C. Belt Stop Bracket
- D. Idler Pulley Belt Guide



# Specifications

*NOTE: Specifications are correct at time of printing and are subject to change without notice.*

## ENGINE:

### 20 HP\* Briggs & Stratton

<b>Make</b>	Briggs & Stratton
<b>Model</b>	Intek
<b>Horsepower</b>	20 @ 3600 rpm
<b>Displacement</b>	30.5 Cu. in (582cc)
<b>Electrical System</b>	12 Volt, 9 amp. Alternator, Battery: 230 CCA
<b>Oil Capacity</b>	64 Oz. (1.9 L)

### 18.5 HP\* Briggs & Stratton

<b>Make</b>	Briggs & Stratton
<b>Model</b>	Intek
<b>Horsepower</b>	18.5 @ 3600 rpm
<b>Displacement</b>	38 Cu. in (502 cc)
<b>Electrical System</b>	12 Volt, 9 amp. Alternator, Battery: 230 CCA
<b>Oil Capacity</b>	48 Oz. (1.4 L)

## CHASSIS:

### LT Series

<b>Fuel Tank Cap.</b>	Capacity: 3.5 Gallons (13,2 L)
<b>Rear Wheels</b>	Tire Size: 22 x 10 -8 Inflation Pressure: 10 psi (.68 bar)
<b>Rear Wheels</b>	Tire Size: 20 x 8.0 -8 Inflation Pressure: 10 psi (.68 bar)
<b>Front Wheels</b>	Tire Size: 15 x 6.0-6 Inflation Press.: 12-14 psi (.82-0,96 bar)

## TRANSMISSIONS:

### K46

<b>Type</b>	Hydrostatic Tuff Torq K46
<b>Hydraulic Fluid</b>	10w 30 Premium Engine Oil
<b>Speeds</b>	Forward: 0-5.5 MPH (9.0 km/h) Reverse: 0-3.0 MPH (4.6 km/h)
<b>@ 3400 rpm</b>	170 ft. lbs.
<b>Continuous Torque Output</b>	
<b>Drawbar Rating</b>	227 lbs (103 kg)
<b>Maximum Weight on Axle</b>	675 lbs (306 kg)

## DIMENSIONS:

### LT Series

<b>Overall Length</b>	72"
<b>Overall Width</b>	37"
<b>Height</b>	45"
<b>Weight</b>	

<b>18.5hp Tractor w/ 38" Mower Deck</b>	480 lbs. (218 kg)
---	-------------------

<b>18.5hp Tractor w/ 40" Mower Deck</b>	500 lbs. (227 kg)
---	-------------------

<b>20hp Tractor w/ 44" Mower Deck</b>	532 lbs. (241 kg)
---------------------------------------	-------------------

*\*Briggs & Stratton Models: The gross power rating for individual gas engine models is labeled in accordance with SAE (Society of Automotive Engineers) code J1940 (Small Engine Power & Torque Rating Procedure), and rating performance has been obtained and corrected in accordance with SAE J1995 (Revision 2002-05). Torque values are derived at 3060 RPM; horsepower values are derived at 3600 RPM. Actual gross engine power will be lower and is affected by, among other things, ambient operating conditions and engine-to-engine variability. Given both the wide array of products on which engines are placed and the variety of environmental issues applicable to operating the equipment, the gas engine will not develop the rated gross power when used in a given piece of power equipment (actual "on-site" or net horsepower). This difference is due to a variety of factors including, but not limited to, accessories (air cleaner, exhaust, charging, cooling, carburetor, fuel pump, etc.), application limitations, ambient operating conditions (temperature, humidity, altitude), and engine-to-engine variability. Due to manufacturing and capacity limitations, Briggs & Stratton may substitute an engine of higher rated power for this Series engine.*

# Parts & Accessories

---



## Replacement Parts

Replacement parts are available from your authorized dealer. Always use genuine Simplicity Service Parts.

## Maintenance Items

Many convenient and helpful service and maintenance items are available from you authorized dealer. Some of these items include:

- |                   |                    |
|-------------------|--------------------|
| Engine Oil        | Tire Sealant       |
| Touch-Up Paint    | Degrimer/Degreaser |
| Grease Gun Kit    | Gas Stabilizer     |
| 8 oz. Grease Tube |                    |

## Technical Manuals

Additional copies of this manual are available, as well as fully illustrated parts lists. These manuals show all of the product's components in exploded views (3D illustrations which show the relationship of parts and how they go together) as well as part numbers and quantities used. Important assembly notes and and torque values are also included.

For applicable manuals currently available for your model, contact our Customer Publications Department at 866-313-6682 (Snapper). Have the information listed in the box below available when phoning in your request. Technical manuals can be downloaded from

[www.simplicitymfg.com](http://www.simplicitymfg.com)

[www.snapper.com](http://www.snapper.com)

<b>Model:</b>	_____
<b>Mfg. No.:</b>	_____
<b>Your Name:</b>	_____
<b>Address:</b>	_____
<b>City, State, Zip:</b>	_____
<b>Visa/Mastercard No.:</b>	_____
<b>Card Expiration Date:</b>	_____





Snapper, INC.  
535 Macon Street  
McDonough, GA 30253

[www.snapper.com](http://www.snapper.com)

Briggs & Stratton Yard Power Products Group  
Copyright © 2008 Briggs & Stratton Corporation  
Milwaukee, WI USA. All Rights Reserved

