

# Safety Instructions & Operator's Manual for **SNAPPER**<sup>®</sup>

## 26" STEEL DECK HIGH WHEEL WALK MOWER SERIES 0



<b>MODEL</b>
<b>HWPS26700BV</b>

MODEL NUMBER EXPLANATION									
	HW	P	S	26	70	0	B	V	
MODEL DESIGNATION	CUTTING WIDTH		ENGINE HP	ENGINE OPTIONS			ENGINE TYPE	SERIES DESIGNATION	
HW - High Wheel Model	26 - 26" Cutting Deck		0 - Series Designation	B - Briggs Engine			V - Over Head Valve		
P - Self-Propelled Machine	70 - 7.0 HP Engine								
S - Swivel Front Wheels									

Thank you for buying a SNAPPER Product! Before operating your machine, read this manual carefully and pay particular attention to the "IMPORTANT SAFETY INSTRUCTIONS" on Pages 2 & 3. Remember that all power equipment can be dangerous if used improperly. Also keep in mind that SAFETY requires careful use in accordance with the operating instructions and common sense!

**SNAPPER**<sup>®</sup> McDonough, GA., 30253 U.S.A.



# IMPORTANT SAFETY INSTRUCTIONS



**WARNING:** This powerful cutting machine is capable of amputating hands and feet and can throw objects that can cause injury and damage! Failure to comply with the following SAFETY instructions could result in serious injury or death to the operator or other persons. The owner of the machine must understand these instructions and must allow only persons who understand these instructions to operate machine. Each person operating the machine must be of sound mind and body and must not be under the influence of any substance, which might impair vision, dexterity or judgment. If you have any questions pertaining to your machine which your dealer cannot answer to your satisfaction, call or write the Customer Service Department at SNAPPER, McDonough, Georgia 30253. Phone: (1-800-935-2967).

## PROTECTION FOR CHILDREN

Tragic accidents can occur if the operator is not alert to the presence of children. Children are often attracted to the machine and the mowing activity. Never assume that children will remain where you last saw them.

1. KEEP children out of the mowing area and under the watchful care of a responsible adult.
2. DO NOT allow children in yard when machine is operated and turn machine OFF if anyone enters the area.
3. DO NOT allow pre-teenage children to operate machine.
4. ALLOW only responsible adults & teenagers with mature judgment under close adult supervision to operate machine.
5. DO NOT pull mower backwards unless absolutely necessary. LOOK and SEE behind and down for children, pets and hazards before and while backing.
6. USE EXTRA CARE when approaching blind corners, shrubs, trees, or other objects that may obscure vision.

## SLOPE OPERATION

1. Slopes are a major factor related to slip and fall accidents, which can result in severe injury. All slopes require extra caution. If you feel uneasy on a slope, DO NOT mow it.
2. Mow across slopes, never up-and-down. Exercise extreme CAUTION when changing directions on slopes. DO NOT mow steep slopes or other areas where stability or traction is in doubt.
3. Use extra care with grass catchers or other attachments; these affect the handling and the stability of the machine.

## PREPARATION

1. Read, understand, and follow instructions and warnings in this manual and on the mower, engine and attachments. Know the controls and the proper use of the mower before starting.
2. Only mature, responsible persons shall operate the machine and only after proper instruction.

## PREPARATION

(Continued From Previous Column)

3. Data indicates that operators age 60 and above, are involved in a large percentage of mower-related injuries. These operators should evaluate their ability to operate the mower safely enough to protect themselves and others from serious injury.
4. Handle fuel with extra care. Fuels are flammable and vapors are explosive. Use only an approved fuel container. DO NOT remove fuel cap or add fuel with engine running. Add fuel outdoors only with engine stopped and cool. Clean spilled fuel and oil from machine. DO NOT smoke.
5. Check the area to be mowed and remove all objects such as toys, wire, rocks, limbs and other objects that could cause injury if thrown by blade or interfere with mowing. Also note the location of holes, stumps, and other possible hazards.
6. Keep people and pets out of the mowing area. Immediately, STOP Blade, Stop engine and Stop mower if anyone enters the area.
7. Check shields, deflectors, switches, blade controls and other safety devices frequently for proper operation and location.
8. Make sure all safety decals are clearly legible. Replace if damaged.
9. Protect yourself when mowing and wear safety glasses, long pants and substantial footwear. DO NOT mow barefooted or with sandals.
10. Know how to STOP blade and engine quickly in preparation for emergencies.
11. Use extra care when loading or unloading the machine into a trailer or truck.
12. Check grass catcher components frequently for signs of wear or deterioration and replace as needed to prevent injury from thrown objects going through weak or torn spots.

## SAFE HANDLING OF GASOLINE

To avoid personal injury or property damage, use extreme care in handling gasoline. Gasoline is extremely flammable and the vapors are explosive

1. Extinguish all cigarettes, cigars, pipes and other sources of ignition.
2. Use only an approved fuel container.



# IMPORTANT SAFETY INSTRUCTIONS



## SAFE HANDLING OF GASOLINE

(Continued From Previous Page)

3. DO NOT remove fuel cap or add fuel with the engine running. Allow the engine to cool before refueling.
4. DO NOT refuel the machine indoors.
5. DO NOT store the machine or fuel container inside where there is an open flame, spark or pilot light such as on a water heater or other appliances.
6. DO NOT fill fuel containers inside a vehicle or on a truck or trailer bed with a plastic liner. Always place the containers on the ground away from the vehicle before filling.
7. Remove gas-powered equipment from the vehicle or trailer and refuel it on the ground. If this is not possible, then refuel equipment using a portable container, rather than a gasoline dispenser nozzle.
8. DO NOT start gas powered equipment in enclosed vehicles or trailers.
9. Keep the nozzle in contact with the rim of the fuel tank or container opening at all times until fueling is complete. DO NOT use a nozzle lock-open device
10. If fuel is spilled on clothing, change clothing immediately.
11. DO NOT overfill a fuel tank. Replace fuel cap and tighten securely.

## OPERATION

1. DO NOT put hands or feet near or under rotating parts. Keep clear of discharge area while engine is running.
2. STOP engine when crossing gravel drives, walks, or roads, and under any conditions where thrown objects might be a hazard.
3. Mow only in daylight or good artificial light.
4. DO NOT operate mower while under the influence of alcohol or drugs.
5. After striking a foreign object or if mower vibrates abnormally, STOP the engine, disconnect and secure spark plug wire. Inspect the mower for any damage and repair the damage.
6. DO NOT mow near drop offs, ditches or embankments. Operator could lose footing or balance.
7. STAY ALERT for holes and other hidden hazards. Tall grass can hide obstacles. Keep away from ditches, washouts, culverts, fences and protruding objects.
8. DO NOT mow on wet grass. Always be sure of your footing. Keep a firm hold on the handle and walk, never run. Slipping could cause injury.
9. DO NOT leave the machine with the engine running. STOP BLADE and STOP ENGINE before leaving the operators position for any reason.
10. Before cleaning, repairing or inspecting make certain engine, blade and all moving parts have STOPPED. Disconnect and secure spark plug wire away from plug to prevent accidental starting.

## OPERATION

(Continued From Previous Column)

11. STOP engine and wait until the blade comes to complete STOP before removing grass bag and/or clearing grass.
12. DO NOT operate mower without the entire grass catcher or guards in place. DO NOT point discharge at people, passing cars, windows or doors.
13. Slow down before turning.
14. Watch out for traffic when near or crossing roadways.
15. DO NOT operate engine in enclosed areas. Engine exhaust gases contain carbon monoxide, a deadly poison.

## MAINTENANCE AND STORAGE

1. DO NOT store mower or fuel container inside where fumes may reach an open flame, spark or pilot light such as in a water heater, furnace, clothes dryer or other gas appliance. Allow engine to cool before storing machine in an enclosure. Store fuel container out of reach of children in a well ventilated, unoccupied building.
2. Keep mower and engine free of grass, leaves or excess grease to reduce fire hazard and engine overheating.
3. When draining fuel tank, drain fuel into an approved container outdoors and away from open flame.
4. Keep all bolts, especially blade bolts, nuts and screws properly tight. Check that all cotter pins are in proper position.
5. Always provide adequate ventilation when running engine. Engine exhaust gases contain carbon monoxide, a deadly poison.
6. Service engine and make adjustments only when engine is stopped. Removed spark plug wire from spark plug and secure wire away from spark plug to prevent accidental starting.
7. DO NOT change engine governor speed settings or overspeed engine.
8. Check grass bag assembly frequently for wear or deterioration to avoid thrown objects and exposure to moving parts. Replace with new bag if loose seams or tears are evident. Replace slider or bag adapter if broken or cracked.
9. Mower blades are sharp and can cut. Wrap the blades or wear heavy leather gloves and use CAUTION when handling them.
10. DO NOT test for spark by grounding spark plug next to spark plug hole; spark plug could ignite gas exiting engine.
11. Have machine serviced by an authorized SNAPPER dealer at least once a year and have the dealer install any new safety devices.
12. Use only genuine SNAPPER replacement parts to assure that original standards are maintained.

# TABLE OF CONTENTS

IMPORTANT SAFETY INSTRUCTIONS .....	2-3
TABLE OF CONTENTS .....	4
SECTION 1 - FAMILIARIZATION .....	5
SECTION 2 - OPERATING INSTRUCTIONS .....	6-9
Pre-start Checklist .....	6
Starting & Stopping Engine & Blades .....	6-7
Starting & Stopping Wheel Drive .....	7
Handle Height Adjustment .....	8
Cutting Height Adjustment .....	8
Swivel Wheel Lock and Unlock .....	9
Recycling Operation .....	9
SECTION 3 - MAINTENANCE INSTRUCTIONS .....	10-11
Service – After First 5 Hours.....	10
Change Engine Oil.....	10
Service Engine.....	10
Grease Front Caster Bushings .....	10
Grease Deck / Blade Spindle .....	10
Check Blade Brake .....	10
Check Engine to Deck Belt.....	10
Check Wheel Drive Belts .....	10
Check Mower Blade .....	11
Check Wheel Drive Control .....	11
Service – Every 25 Operating Hours.....	11
Service - Annually .....	11
Engine.....	11
Air Filter .....	11
Engine Oil.....	11
Storage Procedure.....	11
SECTION 4 - ADJUSTMENTS AND REPAIR.....	12-18
Mower Blade Replacement .....	12
Blade Sharpening .....	12
Wheel Drive Control Adjustment.....	13
Driven Disc Service .....	13
Cleaning Drive Disc and Driven Disc .....	13
Drive Spring Repair/Replacement .....	13
Driven Disc Adjustment.....	14
Replacing Driven Disc Rubber Ring.....	15
Replacing Bearing in Driven Disc.....	15
Replacement of Bearing on Pulley End of Hex Shaft .....	16
Wheel Drive Belt Service.....	16
Engine to Drive Disc Belt Replacement .....	16
Transmission Poly-V Belt Tension Adjustment .....	16
Transmission Poly-V Belt Replacement.....	17
Engine To Deck Belt Tension Adjustment .....	17
Engine to Deck Belt Replacement .....	17
Blade Brake Adjustment .....	18
TROUBLESHOOTING .....	19
SERVICE SCHEDULE.....	20
WARRANTY & PRODUCT REGISTRATION .....	21-22
PRIMARY MAINTENANCE .....	23-26

# Section 1 - FAMILIARIZATION

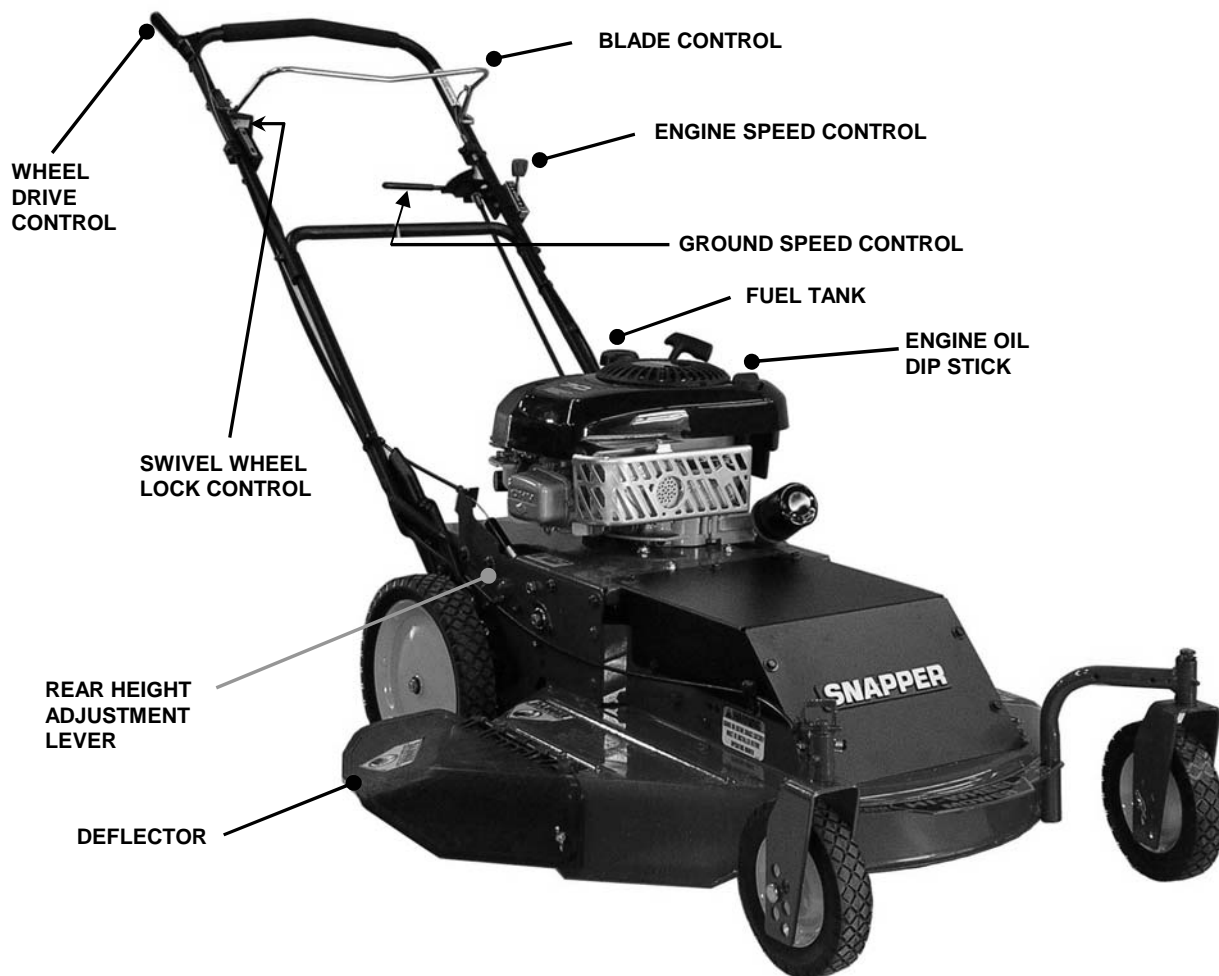

FIGURE 1.1

## 1.1 INTRODUCTION

This manual has been prepared for the operators of the SNAPPER WALK BEHIND MOWERS. Its purpose, aside from recommending operating and routine service requirements, is to promote safety through the use of accepted operating practices. **Read, Understand and Follow** the "IMPORTANT SAFETY INSTRUCTIONS" on Pages 2 & 3 of this manual and all safety messages on the mower and attachments before operating the mower.

**IMPORTANT:** This machine is equipped with a blade brake clutch (BBC). The engine can be started and operated without engaging the blade. The blade can be disengaged (stopped) without stopping engine.

## 1.2 NOMENCLATURE

The nomenclature drawing above, Figure 1.1, shows the essential parts of the SNAPPER WALK BEHIND MOWERS. It is recommended that all operators of the mower become thoroughly familiar with the controls, parts and operation of the mower before operating. Specific details involving the engine are found in the separate engine owner's manual. Study these manuals before operating and keep both handy for future reference.

# Section 2 - OPERATING INSTRUCTIONS

## 2.1 PRE-START CHECK LIST

Familiarize yourself with all controls, instructions and warnings on this machine before attempting to operate it. Know how to stop the wheel drive, stop the blade and stop the engine before starting the engine. Make the following checks and perform the service required before each start-up.

2.1.1. Check guards, deflectors, grass bag, adapter and covers to make sure all are in place and securely tightened.

2.1.2. Check blade control and wheel drive control to insure they work freely. See Figure 2.1.

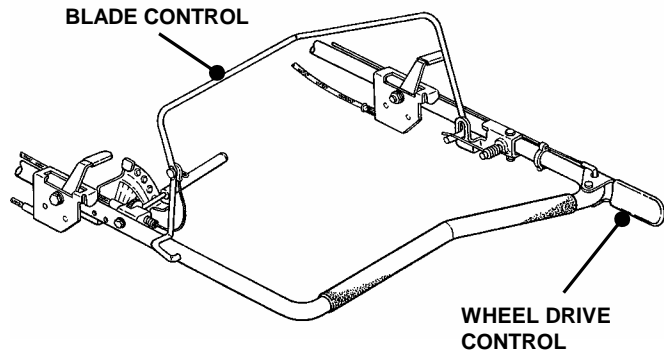

FIGURE 2.1

2.1.3. Check cutting height. Adjust to desired height.

2.1.4. Check engine oil and add oil as needed to bring level up to the full mark. Refer to Engine Owner's Manual for oil specifications. See Figure 2.2.

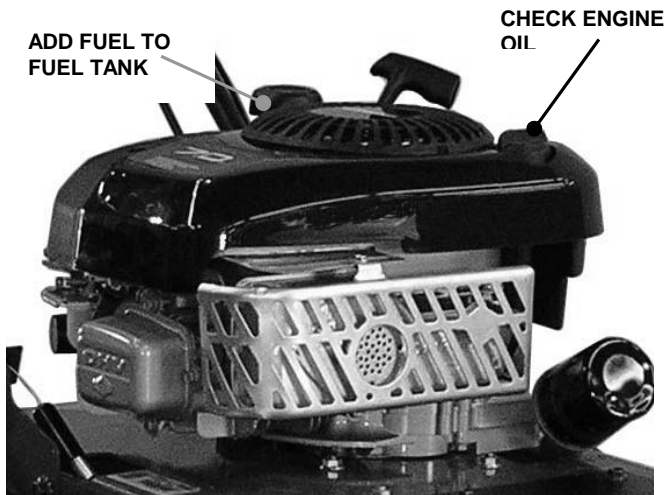

FIGURE 2.2

2.1.5. Add fuel to tank after pushing the mower outside where fumes can safely dissipate. Make sure cap is tightened after refueling. Refer to Engine Owners Manual for specifications.

2.1.6. Clean exterior surfaces of cutting deck and engine of any accumulation of spilled fuel, dirt, grass, oil, etc. Keep engine air intake screen and cooling fins clear at all times.

**WARNING**

**DO NOT** leave machine with engine running.  
**DO NOT** place your hands or feet near the blade while the engine is running!  
**DO NOT** attempt any adjustments, maintenance or service with engine running. **STOP** blade. **STOP** engine.  
**DO NOT** park machine on slopes.

## 2.2 STARTING & OPERATION

### 2.2.1. TO START ENGINE:

1. First, complete Pre-Start Check List.
2. Move engine speed control to the "choke" position. See Figure 2.3. Refer to Familiarization Page.

**IMPORTANT:** Blade control must be in the released "OFF/DISENGAGED" position. **DO NOT** attempt to start the engine with the blade control engaged. Stop the blade by releasing the blade control. Stop the engine by moving the engine speed control to the stop position.

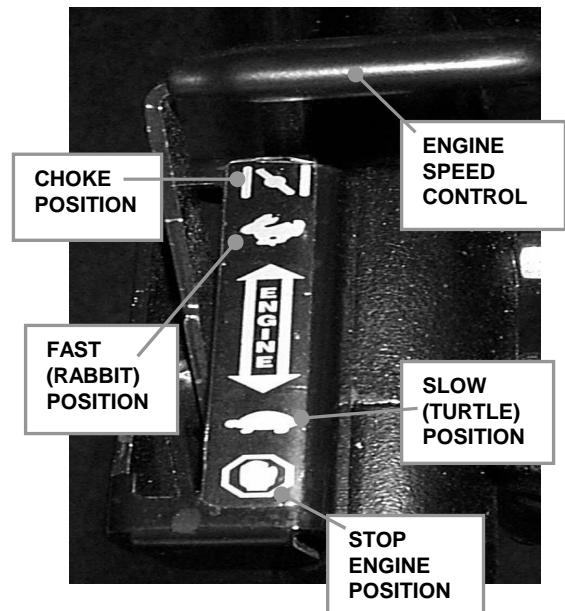

FIGURE 2.3

(Continued on Next Page)

# Section 2 - OPERATING INSTRUCTIONS

## 2.2 STARTING & OPERATION

### 2.2.1. TO START ENGINE (Continued From Previous Page)

3. Stabilize the machine by placing your left foot on the left rear wheel. Machine should be on flat surface where footing is secure.
4. Pull rope start handle to crank engine. Guide rope back into engine. DO NOT let it snap back.
5. After engine starts, move engine speed control away from the choke position to the "Fast" (Rabbit) position. See Figure 2.3.
6. Allow a brief warm-up until engine runs smooth.

### 2.2.2. BLADE

**NOTE:** The blade control requires two motions to engage the blade.

1. To engage blade, Lift up on the blade control. While lifting up, pull blade control back against handle. Blade will engage (rotate). See Figure 2.4.
2. Stop blade by releasing blade control.

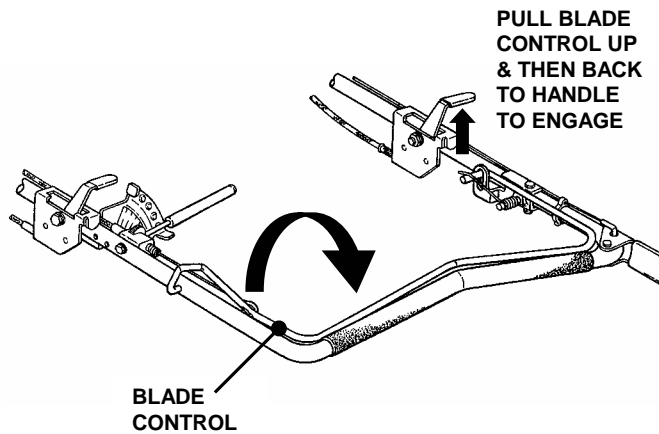

FIGURE 2.4

### 2.2.3. PROPELLING MOWER (WHEEL DRIVE)

1. Move ground speed control to the desired speed position. See Figure 2.5.
2. Move wheel drive control against handle to engage wheel drive and propel mower forward. Forward speed can be adjusted while the mower is moving by changing position of the ground speed control. See Figure 2.5.
3. Stop wheel drive by releasing the wheel drive control.

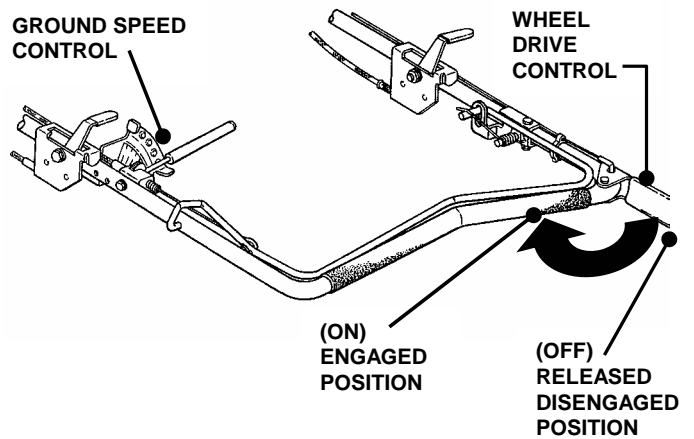

FIGURE 2.5

## 2.3 STOPPING

### 2.3.1. WHEEL DRIVE

Stop wheel drive by releasing wheel drive control. Engine and blade will continue to operate when wheel drive control is released.

### 2.3.2. BLADE

Stop blade by releasing blade control. Engine will continue to operate when blade control is released. The engine and the wheel drive can be operated with the blade disengaged (OFF).

	<b>WARNING</b>	
<p>The blade should come to a complete stop in 3 seconds or less after the blade control is released. If the blade continues to rotate after 3 seconds, the blade brake must be adjusted. DO NOT operate machine if blade brake is not functioning properly.</p>		

### 2.3.3. ENGINE

Stop the engine by moving the engine speed control back to the STOP position.

	<b>WARNING</b>	
<p>DO NOT leave machine with engine running. STOP blade. STOP engine. DO NOT park machine on slopes.</p>		

## Section 2 - OPERATING INSTRUCTIONS

**WARNING**

DO NOT attempt any adjustments, maintenance or service with the engine or blade running. STOP blade. STOP engine. Remove spark plug wire from spark plug and secure wire away from spark plug. Engine and components can be extremely hot. Avoid burns by allowing engine and components sufficient time to cool.

### 2.4 HANDLE HEIGHT ADJUSTMENT

The height of the mower handle can be adjusted as follows:

1. Loosen the nuts on each lower handle bracket as shown in Figure 2.6.

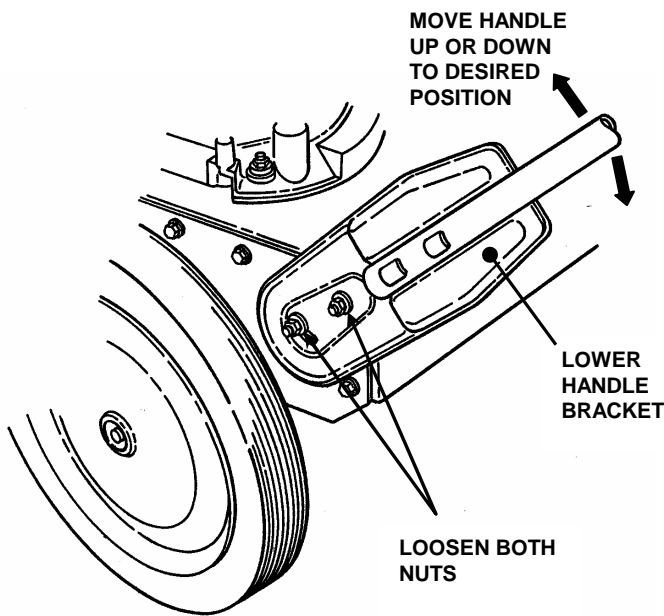

FIGURE 2.6

2. Move upper handle up or down until the desired position is achieved.
3. Tighten the lower nuts securely (12 to 22 ft. lbs.) on each lower handle bracket to maintain desired position.

### 2.5 CUTTING HEIGHT ADJUSTMENT (Rear Wheels)

1. Pull the rear height adjusting latch outward and move to desired cutting height. See Figure 2.7.

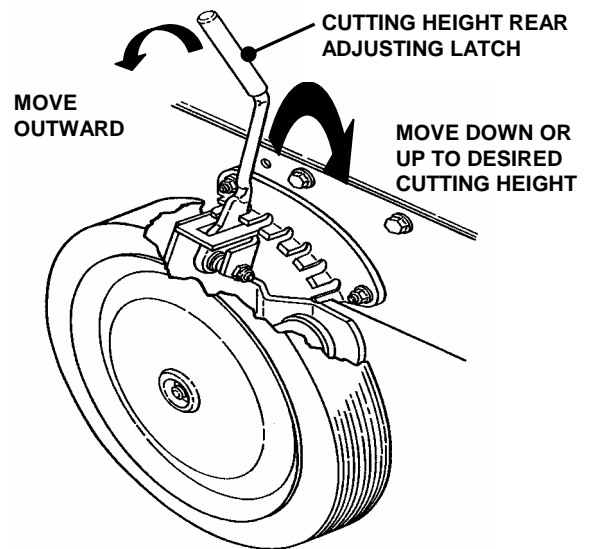

FIGURE 2.7

### 2.5 CUTTING HEIGHT ADJUSTMENT (Front Wheels)

2. Remove hair pin and clevis pin. Install pin in highest hole for lowest cutting height and lowest hole for highest cutting height. See Figure 2.8.

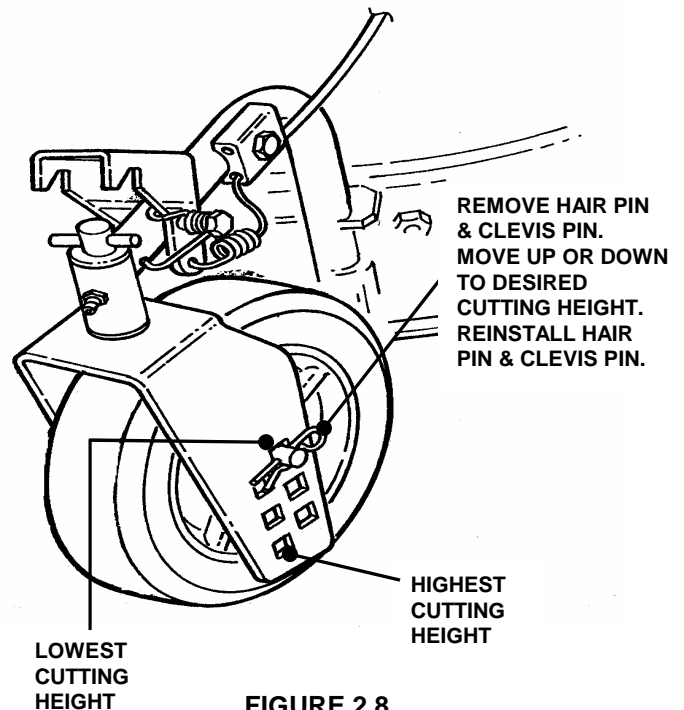

FIGURE 2.8



## Section 2 - OPERATING INSTRUCTIONS

**WARNING**  
Cutting on slopes is dangerous. Exercise extreme caution. Loss of footing can result in serious injury. Cut across slopes - never up and down. Practice on slopes with blade off.

### 2.6 SWIVEL WHEEL LOCK and UNLOCK

**IMPORTANT:** Engage the lock on the swivel wheel to maintain better control of machine when operating on slopes.

1. Stand in the operator's position. Push machine forward until swivel wheel is positioned in the forward direction. Wheel must be positioned in a forward direction to engage swivel wheel lock.
2. Push wheel lock lever forward to lock swivel wheel in place. Swivel wheel will stay in the forward direction position. See Figure 2.9.
3. Pull wheel lock lever rearward to unlock swivel wheel. In the unlocked position, the swivel wheel will rotate 360 degrees.

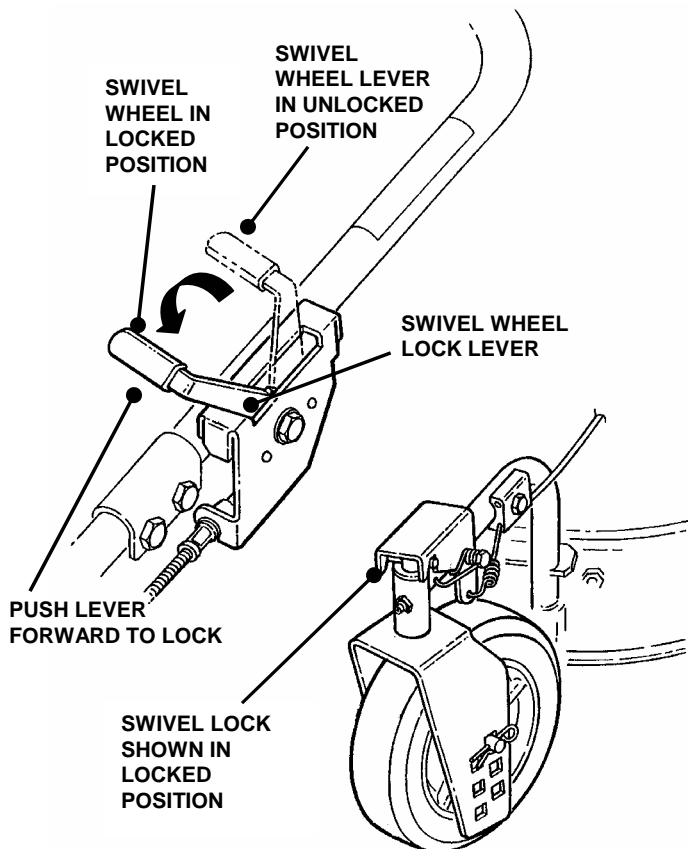

FIGURE 2.9

### 2.7 RECYCLING OPERATION (OPTIONAL)

Recycling operation requires an optional accessory. Contact your local Snapper dealer for details.

**NOTE:** For best recycling results, cut up to a maximum of 1/3 of grass blade length and recycle ONLY when grass is dry.

1. Set all wheels in the highest cutting position (Notch 6).
2. Move engine speed control to "FAST" (Rabbit) position.
3. Move ground speed control to slowest speed setting.
4. Proceed mowing slowly. If grass is very dense, lower each rear wheel latch one notch lower than the front wheel to improve recycling performance.

## Section 3 - MAINTENANCE

### 3.1 INTRODUCTION

To retain the quality of the mower, use genuine SNAPPER replacement parts only. Contact a local SNAPPER dealer for parts and service assistance. For the correct part or information for a particular mower, always mention model and serial number.

### 3.2.2. SERVICE ENGINE



Service engine air cleaner. Refer to engine owner's manual for proper air filter specification and maintenance procedure.

### 3.2.3. GREASE FRONT CASTER BUSHINGS

Grease front caster bushing with three shots of general purpose grease from a grease gun.

### 3.2.4. GREASE DECK/BLADE SPINDLE

Grease deck/blade spindle with three shots of general purpose grease from a grease gun.



 **WARNING** 

**DO NOT attempt any adjustments, maintenance or service with the engine or blade running. STOP blade. STOP engine. Remove spark plug wire from spark plug and secure wire away from spark plug. Engine and components can be extremely hot. Avoid burns by allowing engine and components sufficient time to cool.**

### 3.2 SERVICE - AFTER FIRST 5 HOURS

#### 3.2.1. CHANGE ENGINE OIL

The easiest and cleanest method to drain the engine oil requires the machine to be tipped, RIGHT side up. The oil can then be quickly drained from the engine oil filler tube. Tipping the machine can produce fuel leakage. To avoid the fire and explosion hazards of spilled fuel the tank must be empty or carefully drained before tipping machine.

 **WARNING** 

**The blade should come to a complete stop in 3 seconds or less after the blade control is released. If the blade continues to rotate after 3 seconds, the blade brake must be adjusted. DO NOT operate machine if blade brake is not functioning properly.**

#### 3.2.5. CHECK BLADE BRAKE



Check blade brake for proper function. Blade should stop in 3 seconds or less after releasing blade control. Refer to Section "BLADE BRAKE ADJUSTMENT" in this manual for adjustment procedure.

#### 3.2.6. CHECK ENGINE to DECK BELT

Visually check engine to deck belt for cracking, fraying, severed or belt strands exposed. Replace belt before operating mower. Verify proper belt tension. Refer to Section "ENGINE TO DECK BELT SERVICE" in this manual for belt tension adjustment and engine to deck belt replacement.

#### 3.2.7. CHECK WHEEL DRIVE BELTS

Visually check belts for cracking, fraying, severed or belt strands exposed. Replace belts before operating mower. Verify proper belt tension. Refer to Section "WHEEL DRIVE BELT SERVICE" for belt tension adjustment and wheel drive belt replacement instructions.

 **WARNING** 

**Before tipping machine, run engine until fuel tank is empty or drain fuel tank. Fuels are flammable and vapors are explosive. When draining fuel tank, drain fuel into an approved container outdoors and away from open flame and all sources of ignition.**

1. Run engine until fuel tank is empty or drain fuel tank. When cool, remove spark plug wire from spark plug and secure away from spark plug.
2. Tip machine with right side of machine up.
3. Place shallow 2 quart drain pan below the oil dip stick cap.
4. Remove dip stick and allow engine oil to drain into pan.
5. Move pan so that it is below the engine oil filter.
6. Remove oil filter and allow oil to drain into pan.
7. Install new oil filter. Refer to Engine Operator's manual for specifications.
8. Place machine back on four wheels.
9. Fill engine crankcase to proper level. Refer to Engine Operator's manual for proper oil specifications.
10. Install dip stick and tighten cap.
11. Dispose of drained oil properly.
12. Attach spark plug wire to spark plug.

**NOTE:** Wipe up any spilled oil off machine before operating.

**(Continued on Next Page)**

# Section 3 - MAINTENANCE

**WARNING**

**DO NOT** attempt any adjustments, maintenance or service with the engine or blade running. **STOP** blade. **STOP** engine. Remove spark plug wire from spark plug and secure wire away from spark plug. Engine and components can be extremely hot. Avoid burns by allowing engine and components sufficient time to cool. Wear heavy leather gloves when handling or working around cutting blades. Blades are extremely sharp and can cause severe injury.

### 3.2 SERVICE - AFTER FIRST 5 HOURS

(Continued From Previous Page)

#### 3.2.8. CHECK MOWER BLADE

1. Disconnect spark plug wire and secure end away from plug.
2. Tilt mower up on its rear wheels for access to the blade bolts. Do not tilt mower with spark plug or carburetor down. See Figure 3.1.
3. Check torque of blade retaining bolts. Recommended torque is 30 to 40 ft. lbs. See Figure 3.3.
4. Check blade for sharpness, wear and damage. See Section on Blade Wear Limits.

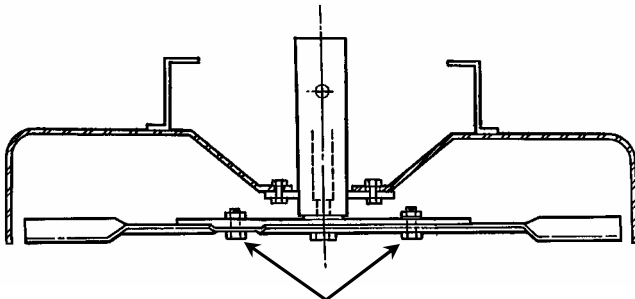

CHECK TORQUE OF BLADE BOLTS

FIGURE 3.1

#### 3.2.9. CHECK WHEEL DRIVE CONTROL

The wheel drive requires periodic adjustment to maintain belt tension and proper wheel drive function. The adjustment is accomplished through the spring attached to the end of the wheel drive control cable. Refer to Section "WHEEL DRIVE CONTROL ADJUSTMENT" for the procedure to perform this adjustment.

### 3.3 SERVICE – EVERY 25 OPERATING HOURS

Perform all service described in Section "SERVICE – AFTER FIRST 5 HOURS", and all maintenance required in "Service Schedule".

### 3.4 SERVICE - ANNUALLY

Perform all maintenance as described in the maintenance schedule.

#### 3.4.1. Engine

Service engine according to engine owner's manual.

#### 3.4.2. Air Filter

Refer to engine owner's manual for service instructions.

#### 3.4.3. Engine Oil

Refer to engine owner's manual for service instructions.

### 3.5 STORAGE PROCEDURE

Refer to the Engine Owner's Manual for directions regarding engine storage preparations. Prepare the mower for "End of Season" storage as follows:

1. Drain fuel from fuel tank and let engine run until all fuel is out of the carburetor. Turn fuel valve off.
2. **Disconnect and remove the spark plug wire away from spark plug before any other preparations are made!**
3. Tape all openings closed to prevent spraying water into exhaust or air intakes during washing.
4. Tilt mower up on its rear wheels and thoroughly clean the underside of the deck. Do not tilt mower with spark plug or carburetor down. Scrape away any accumulation of grass with a putty knife and or wire brush.
5. Lubricate all exposed metal with a light coating of oil to prevent corrosion.

## Section 4 - REPAIR & ADJUSTMENTS

**WARNING**

DO NOT attempt any adjustments, maintenance or service with the engine or blade running. STOP blade. STOP engine. Remove spark plug wire from spark plug and secure wire away from spark plug. Engine and components can be extremely hot. Avoid burns by allowing engine and components sufficient time to cool. Wear heavy leather gloves when handling or working around cutting blades. Blades are extremely sharp and can cause severe injury.

### 4.1 MOWER BLADE REPLACEMENT

#### 4.1.1. STANDARD BLADE WEAR LIMIT

1. Inspect blade frequently for signs of excessive wear or damage. See Figure 4.1.

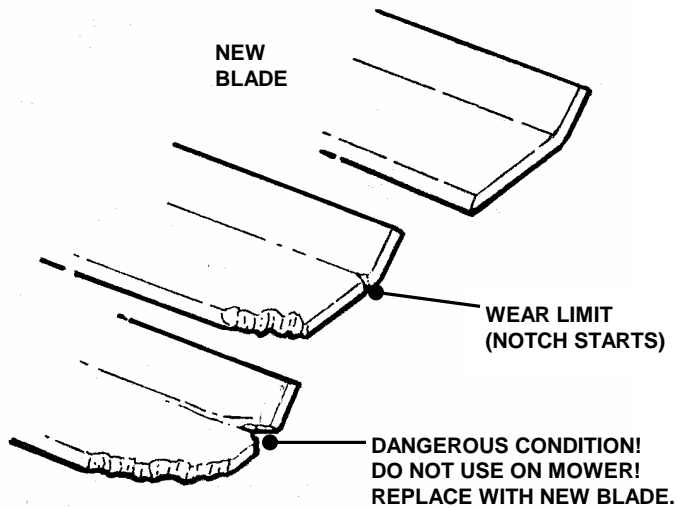

FIGURE 4.1

2. Replace the blade if it is badly chipped, bent, noticeably out of balance or has cracks or notch in either tip. See Figure 4.1. Replace with new blade.

**WARNING**

DO NOT use a cutting blade that shows signs of excessive wear or damage. Refer to Section "MOWER BLADE REPLACEMENT" for proper blade inspection and service procedures.

#### 4.1.2. BLADE SHARPENING

1. Disconnect spark plug wire and secure end away from plug.
2. Tilt mower up on its rear wheels. Do not tilt mower with spark plug or carburetor down.
3. Remove blade. See Figure 4.2.

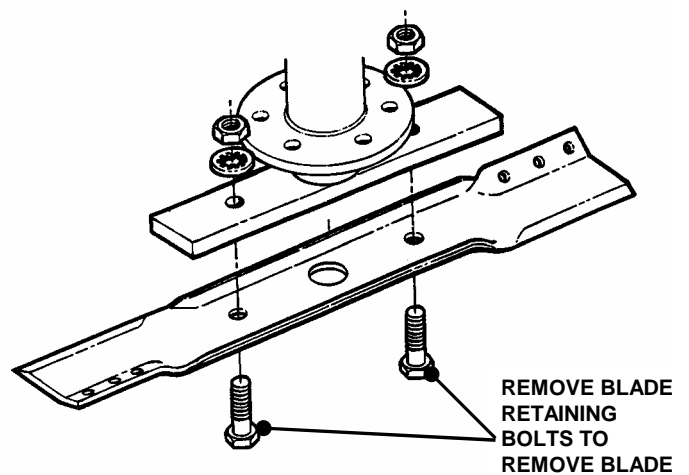

FIGURE 4.2

4. Sharpen blade on a grinding wheel at an angle of 22 to 28 degrees. DO NOT sharpen beyond original cutting edge. See Figure 4.3.

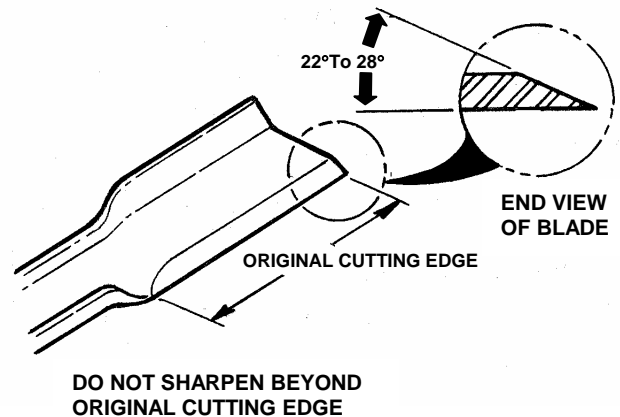

FIGURE 4.3

5. Check blade for balance. If necessary, correct balance by grinding heavy end of blade.
6. Reinstall blade. See Figure 4.2. Check torque of blade retaining bolts. Recommended torque should be 30 to 40 ft. lbs.

## Section 4 - REPAIR & ADJUSTMENTS

**WARNING**

**DO NOT** attempt any adjustments, maintenance or service with the engine or blade running. **STOP** blade. **STOP** engine. Remove spark plug wire from spark plug and secure wire away from spark plug. Engine and components can be extremely hot. Avoid burns by allowing engine and components sufficient time to cool. Wear heavy leather gloves when handling or working around cutting blades. Blades are extremely sharp and can cause severe injury.

### 4.2 WHEEL DRIVE CONTROL ADJUSTMENT

**IMPORTANT:** There should always be some slack in the wheel drive control cable when the wheel drive control is released.

The Wheel Drive Control requires periodic adjustment to maintain proper belt tension on the transmission poly-v belt. Verify proper tension by checking the extension of the spring located at the end of the wheel drive control cable.

1. Stop engine and allow sufficient time to cool.
2. Engage wheel drive control. The length of the spring located at the end of the drive control cable should increase between  $\frac{1}{2}$ " and  $\frac{3}{4}$ ". See Figure 4.4. If the spring does not increase between  $\frac{1}{2}$ " and  $\frac{3}{4}$ ", adjustment is required.
3. To adjust the amount the spring extends (belt tension) slide the black spring cover up to expose the spring. Unhook the cable eyelet from the spring.
4. Grip the hook on the spring and turn either Clockwise or Counter-clockwise. Clockwise increases spring extension and belt tension Counter-clockwise decreases spring extension and belt tension.
5. Attach the control cable eyelet to the spring and recheck spring extension. If spring extension is correct slide the spring cover down over the spring. Start engine, and with blade control released (blade stopped) verify the wheel drive functions properly. If spring extension is not correct turn spring Clockwise / Counter-clockwise.
6. If drive problems persist after adjusting the spring extension Refer to Section "TROUBLESHOOTING" of this manual or contact your local Snapper Dealer for assistance.

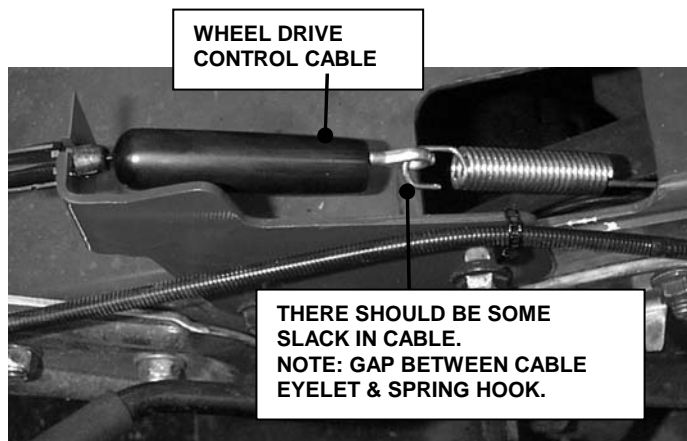

**FIGURE 4.4**

### 4.3 DRIVEN DISC SERVICE

**Note:** Slippage may be due to improper adjustment of clutch cable, worn belts, oily belts or broken springs. If the mower does not propel itself properly, check for the following problems:

1. Grease & oil on drive disc causing slippage.
2. Broken or disconnected drive spring.
3. Driven disc is out of adjustment.
4. Driven disc rubber ring is worn - does not contact drive disc properly.
5. Worn Poly-V Belt or engine drive belt.

**NOTE:** If any of the above (1 thru 5) are causing problems, service as follows:

#### 4.3.1. Cleaning Drive Disc & Driven Disc.

If oil or grease on the drive disc or driven disc is causing slippage, clean discs as follows:

1. Wipe away any oil or grease with a clean cloth.
2. Use either an approved grease solvent or hot, soapy water to clean drive disc or driven disc.
3. Rinse components with clean water.
4. Dry components with a clean cloth.

#### 4.3.2. Drive Spring Repair/Replacement

If drive spring is disconnected, reinstall onto thrust plate. If spring is broken, replace with new spring.

## Section 4 - REPAIR & ADJUSTMENTS



### WARNING



DO NOT attempt any adjustments, maintenance or service with the engine or blade running. STOP blade. STOP engine. Remove spark plug wire from spark plug and secure wire away from spark plug. Engine and components can be extremely hot. Avoid burns by allowing engine and components sufficient time to cool.

#### 4.3.3. DRIVEN DISC ADJUSTMENT

The driven disc position is set at the factory and should not require adjustment. The proper adjustment is displayed in Figure 4.5. If adjustment is required proceed as follows.

1. Loosen jam nut from ball joint on transfer rod.

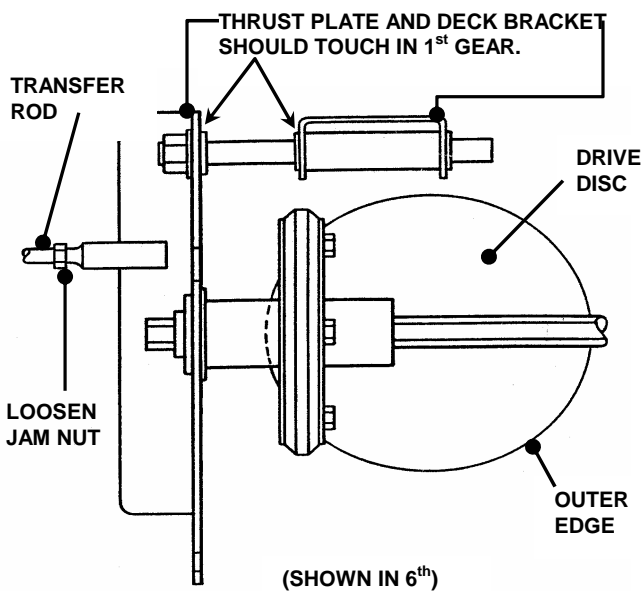

FIGURE 4.5

2. Remove transfer rod retaining clip. See Figure 4.6.

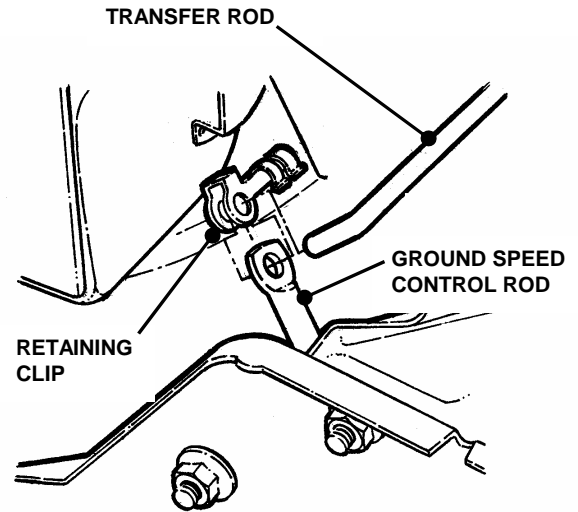

FIGURE 4.6

3. Remove driven disc spring.
4. Place ground speed in the 1st speed position.
5. The thrust plate and deck bracket should touch in 1<sup>st</sup> gear.
6. Adjust transfer rod by rotating clockwise or counter-clockwise as needed until it will just slide into hole on ground speed control rod.
7. Attach transfer rod to speed control rod and install retaining clip.
8. Tighten jam nut on transfer rod ball joint.
9. Attach spring to thrust plate.

## Section 4 - REPAIR & ADJUSTMENTS

**WARNING**

**DO NOT** attempt any adjustments, maintenance or service with the engine or blade running. **STOP** blade. **STOP** engine. Remove spark plug wire from spark plug and secure wire away from spark plug. Engine and components can be extremely hot. Avoid burns by allowing engine and components sufficient time to cool.

### 4.3.4. Replacing Driven Disc Rubber Ring

If the rubber ring is badly chunked or worn down to within 1/16" of the metal rim of the driven disc hub, it must be replaced.

1. Remove the clip from the transfer rod. Then remove the transfer rod from the clip and the speed control rod and swing rod towards driven ring. See Figure 4.7.

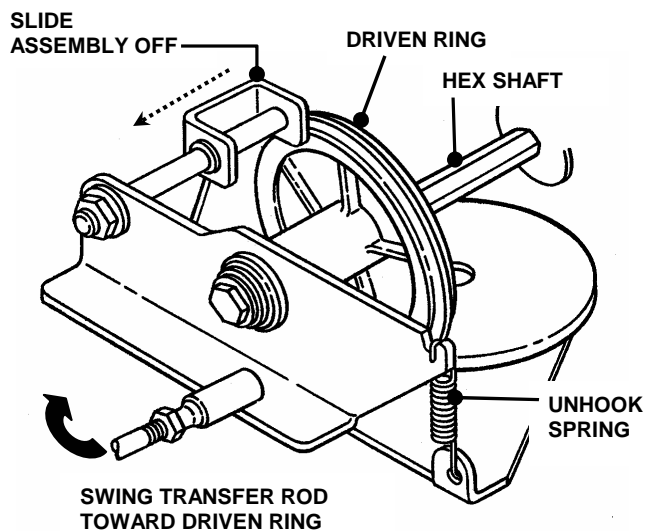

FIGURE 4.7

2. Remove belt guide for the engine to deck belt.
3. Unhook the driven disc spring and slide the driven disc assembly off the hex shaft. See Figure 4.7.
4. Remove the five machine screws and plate that secures the rubber ring to the driven disc hub. See Figure 4.8.
5. Install new rubber ring.
6. Reverse above procedures for reassembly and installation.

**NOTE:** When reinstalling belt guide, position the guide 1/8" from belt with belt in the engaged position.

### 4.3.5. Replacing Bearing In Driven Disc

If the driven disc bearing fails, remove the driven disc assembly and replace bearing as follows:

1. Remove snap ring.
2. Slide the hub assembly out of the bearing.
3. Remove the four screws.
4. Remove bearing and replace with new bearing.
5. Reassemble components in reverse order.

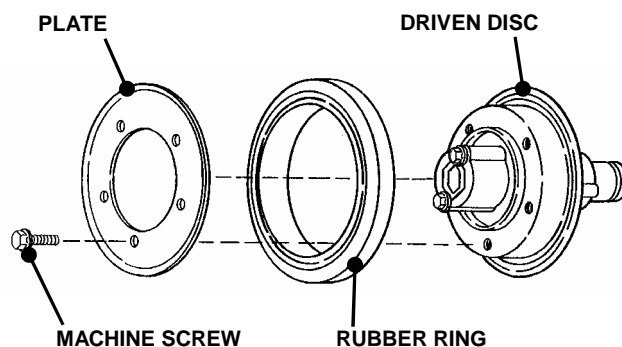

FIGURE 4.8

## Section 4 - REPAIR & ADJUSTMENTS

**WARNING**

**DO NOT** attempt any adjustments, maintenance or service with the engine or blade running. **STOP** blade. **STOP** engine. Remove spark plug wire from spark plug and secure wire away from spark plug. Engine and components can be extremely hot. Avoid burns by allowing engine and components sufficient time to cool.

### 4.3.6. Replacement Of Bearing On Pulley End Of Hex Shaft

To replace the bearing on the pulley end of the hex shaft, proceed as follows:

1. Hold the hex shaft with an adjustable wrench held next to the pulley.
2. Remove the 3/8" hex lock nut, which is located on the outside of the right wheel bracket. See Figure 4.10.
3. Remove holder, O-ring and bearing.
4. Install new bearing.
5. Carefully install new O-ring over the outside of the new bearing.
6. Install bearing holder and secure with screws.
7. Install 3/8" hex lock nut.

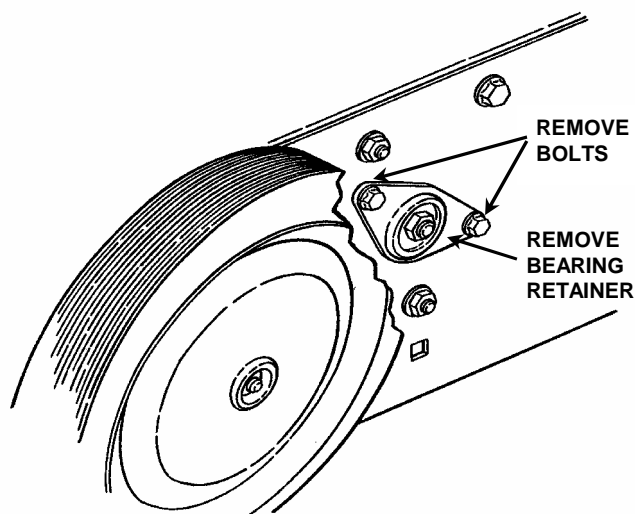

FIGURE 4.10

### 4.4. WHEEL DRIVE BELT SERVICE

On this machine, the engine belt transmits power from the engine to the drive disc. The drive disc powers the poly-v belt, which engages the transmission that powers the rear wheels. Should these belts become worn, they could cause slippage. The condition of the engine belt and poly-v belt should be checked after every 25 hours of mower operation.

#### 4.4.1. Engine to Drive Disc Belt Replacement

1. Empty the fuel tank.
2. Unhook the idler spring and driven disc spring. See Figure 4.7.
3. Roll belt off of engine pulley
4. Remove belt from drive disc pulley groove and slide underneath driven disc
5. Reverse procedure to install new belt.

**NOTE:** The engine to drive disc belt does not require tension adjustment.

#### 4.4.2. Transmission Poly-V Belt Tension Adjustment (Wheel Drive Control)

The transmission poly-v belt is tensioned by the spring on the end of the wheel drive control cable. Engaging the wheel drive control extends the spring applying tension to the belt, causing the drive to propel the mower. When engaged the spring should extend between 1/2" & 3/4". If extension falls out of this range adjustment is required. Refer to Section "WHEEL DRIVE CONTROL ADJUSTMENT" for the procedure.



## Section 4 - REPAIR & ADJUSTMENTS



### WARNING



DO NOT attempt any adjustments, maintenance or service with the engine or blade running. STOP blade. STOP engine. Remove spark plug wire from spark plug and secure wire away from spark plug. Engine and components can be extremely hot. Avoid burns by allowing engine and components sufficient time to cool.

#### 4.4.3. Transmission Poly-V Belt Replacement

1. Remove the driven disc. Refer to Section "REPLACING DRIVEN DISC RUBBER RING" for procedure.
2. Note the routing of the old belt around the three pulleys before removing it. See Figure 4.11.

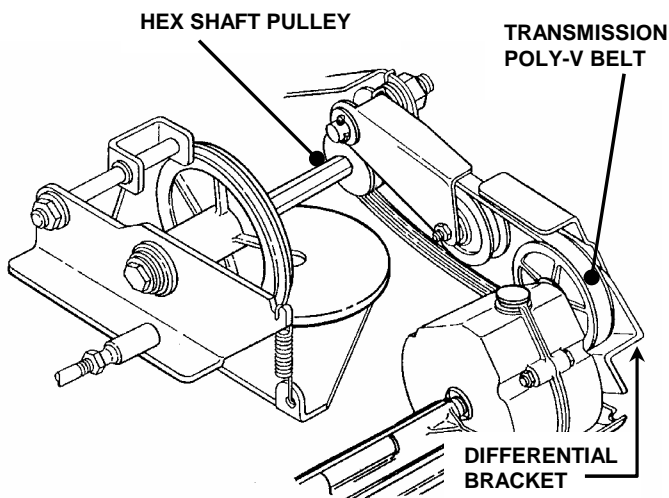

FIGURE 4.11

3. Remove poly-v belt from transmission pulley by turning belt sideways and slipping between nut and differential bracket.
4. Slip belt off of belt idler.
5. Remove belt from hex shaft pulley.
6. Place new Poly-V Belt over end of hex shaft and onto driven pulley.
7. Work belt onto top of idler pulley.
8. Twist belt sideways and pull it upward between the differential bracket and drive pulley and then down into the pulley groove. Make sure the Poly-V Belt is above belt guide.

#### 4.5 Engine To Deck Belt Service

##### 4.5.1. Engine To Deck Belt Tension Adjustment

The engine to deck belt transmits power from the engine to blade. This belt during normal service will require periodic tension adjustment.

1. Remove spindle cover.
2. Locate blade control spring. See Figure 4.12.

3. With engine off, engage blade control. The length of the spring should increase by 1/4" to 3/8" for proper belt tension.

4. To obtain proper tension, turn the thumb screw located on the upper left handle until the spring extension is 1/4" to 3/8".

5. Install spindle cover.

##### 4.5.2. Engine to Deck Belt Replacement

1. Remove the engine to drive disc belt as described in Section on Wheel Drive Belt Service.

2. Remove spindle cover.

3. Remove belt from spindle pulley.

4. Loosen idler pulley and remove belt from between guide and idler pulley.

5. Remove drive disc belt from engine pulley.

6. Remove deck belt from engine pulley.

7. Reverse to install new belt.

**NOTE:** Check to make sure belt is routed inside the belt guides. Verify proper belt tension by engaging blade control. Adjust thumb screw until spring is extended 1/4" to 3/8".

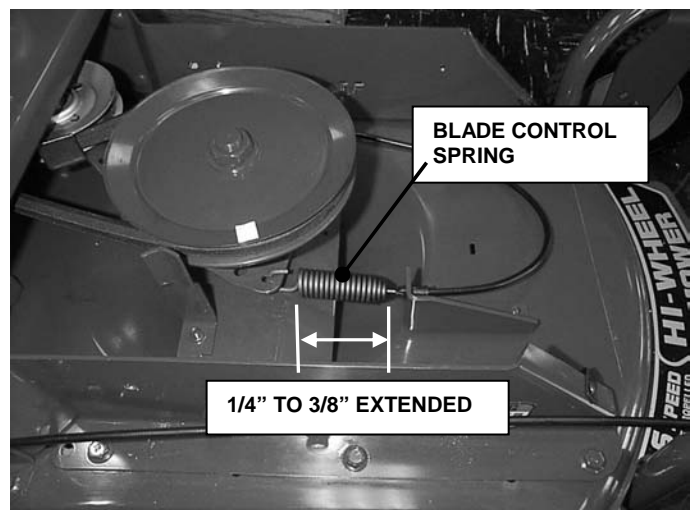
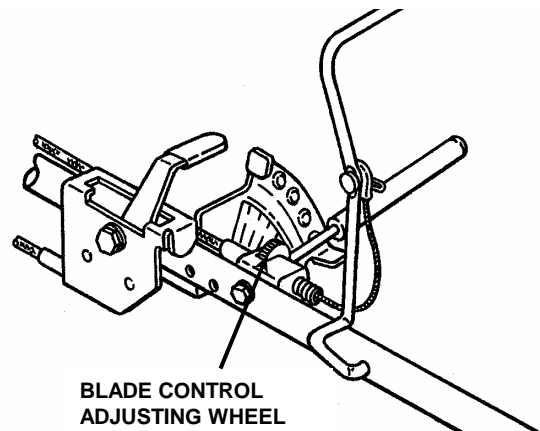

FIGURE 4.12

## Section 4 - REPAIR & ADJUSTMENTS

**WARNING**

DO NOT attempt any adjustments, maintenance or service with the engine or blade running. STOP blade. STOP engine. Remove spark plug wire from spark plug and secure wire away from spark plug. Engine and components can be extremely hot. Avoid burns by allowing engine and components sufficient time to cool.

**WARNING**

DO NOT use machine if blade brake does not function properly.

### 4.6 BLADE BRAKE ADJUSTMENT

The blade should come to a complete stop in 3 seconds or less after releasing the blade control. If the blade continues to rotate after 3 seconds perform the following adjustment.

1. Remove spindle cover.
2. Rotate blade brake eye bolt nut one full turn CLOCKWISE to increase brake tension. See Figure 4.13.
3. Recheck blade stop time. If blade continues to rotate after 3 seconds turn eye bolt nut an additional one full turn CLOCKWISE.
4. Recheck blade stop time. If still over 3 seconds—DO NOT OPERATE MACHINE. Contact an authorized Snapper dealer for assistance.
5. Reinstall deck cover.

**IMPORTANT:** DO NOT turn eye bolt nut more than two turns. Over tightening brake can cause damage to other components and improper function of blade belt drive.

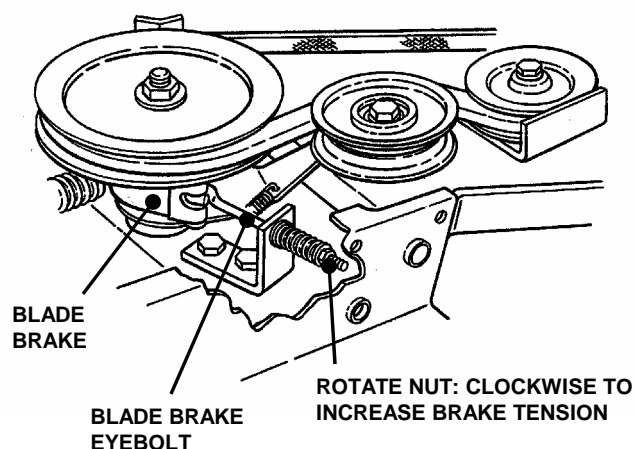

FIGURE 4.13

# TROUBLESHOOTING

PROBLEM	PROBABLE CAUSE	CORRECTIVE ACTION
<b>Engine Will Not Start Using Recoil Starter</b>	1. Fuel tank empty or fuel valve OFF.	1. Fill fuel tank with fresh fuel. Turn valve ON.
	2. Engine needs choking.	2. Move choke control to "CHOKE" position.
	3. Spark plug wire disconnected.	3. Place spark plug wire onto spark plug.
	4. Engine speed control in STOP position.	4. Move control to choke or fast position.
<b>Engine Stalls or Stops After Running</b>	1. Choke control in the "CHOKE" position.	1. Move choke control to "OFF" position.
	2. Fuel tank empty.	2. Fill with fuel to proper level.
	3. Engine air pre-cleaner and or air cleaner dirty.	3. Clean free of all debris.
	4. Spark plug defective or gap set improperly.	4. Service spark plug.
	5. Water, debris or stale fuel in fuel system.	5. Drain and clean fuel system.
<b>Engine Loses Power</b>	1. Engine air pre-cleaner or air cleaner dirty.	1. Clean or replace filters.
	2. Spark plug faulty.	2. Service spark plug.
	3. Water, debris or stale fuel in fuel system.	3. Drain and clean fuel system.
<b>Excessive Vibration</b>	1. Damaged, out of balance or bent mower blades.	1. Service mower blade(s).
	2. Loose blade components.	2. Service and tighten loose parts.
	3. Loose or missing air lift (if equipped).	3. Replace air lifts. Tighten to proper torque.
	4. Lumpy or frayed belt.	4. Replace belt.
	5. Bent Idler pulley.	5. Replace pulley.
<b>Mower Will Not Move Loss Of Traction (Self-Propelled Models)</b>	1. Damaged transmission.	1. Contact authorized <b>SNAPPER</b> dealer.
	2. Traction drive belt requires replacement.	2. Replace traction drive belt.
	3. Driven disc slipping.	3. Clean or replace driven disc.
<b>Cutting Grass Improperly</b>	1. Cutting height too low or high.	1. Adjust cutting height.
	2. Engine speed too slow.	2. Move engine speed control to "FAST" position.
	3. Forward ground speed too fast.	3. Move ground speed control to a slower speed.
	4. Terraced cut, side to side.	4. Adjust height of cut with height adjust levers.
	5. Excessive deck pitch, front to rear.	5. Adjust height of cut with height adjust levers.
	6. Cutting blade(s) dull or damaged.	6. Sharpen cutting edges or replace blade(s).
<b>Poor Grass Discharge</b>	1. Engine speed too slow.	1. Move engine speed control to "FAST" position.
	2. Forward speed too fast.	2. Move ground speed control to a slower speed.
	3. Grass is wet.	3. Mow when grass is dry.
	4. Excessively worn or damaged blade(s).	4. Service mower blade(s).
	5. Build up of grass clippings and debris under deck.	5. Clean deck.
	6. Improper blade(s) installed on deck.	6. Install proper <b>SNAPPER</b> blades.
	7. Blade(s) installed improperly on deck.	7. Install blades properly.
<b>Oil Leaking</b>	1. Leaking engine case.	1. Contact authorized <b>SNAPPER</b> dealer. 2. Check and tighten drain plug. 3. Make sure dip stick or oil filler cap is securely in place.

# SERVICE SCHEDULE

ITEM	SERVICE PERFORMED	REF.	EACH USE	5 HRS	25 HRS	50 HRS	100 HRS	EACH SEASON
<b>Engine Oil</b>	Check Oil Level	Engine Manual	X					
	Initial Oil Change	Page 10		X				
	Periodic Oil Change	Page 10			X*			
<b>Oil Filter</b>	Replace with Oil Change	Engine Manual			X*			
<b>Air Pre-Cleaner</b>	Clean Sponge Element	Engine Manual			X**			
<b>Air Cleaner</b>	Clean or Replace	Engine Manual.			X**			
<b>Spark Plug</b>	Replace	Engine Manual.					X	
<b>Engine Cooling System</b>	Clean Shroud & Fins	Engine Manual					X**	
<b>Drive Belts</b>	Check For Wear And Tension	Page 10 & 17			X	X		X
<b>Mower Blades</b>	Check For Wear, Damage & Replacement	Page 12	X					
<b>Mower Deck</b>	Clean Debris Accumulation	Page 6	X					
<b>Drive Disc</b>	Check for Wear Damage & Replacement	Page 13-15				X		
<b>Blade Brake</b>	Check Blade Brake Function	Page 10	X					
<b>Blade Spindle</b>	Lubricate	Page 10			X			
<b>Front Caster Bushings</b>	Lubricate	Page 10			X			

\* Change oil every 25 hours when operating under heavy load or high temperatures.

\*\*Clean more often under dusty conditions or when air debris is present.

# **SNAPPER®**

## **2 YEAR LIMITED WARRANTY**

For two (2) years from purchase date for the original purchaser's residential, non-commercial use, **SNAPPER**, through any authorized **SNAPPER** dealer will replace, free of charge (except for taxes where applicable), any part or parts found upon examination by the factory at McDonough, Georgia, to be defective in material or workmanship or both.

For ninety (90) days from purchase date for the original purchaser's commercial, rental, or other non-residential use, **SNAPPER**, through any authorized **SNAPPER** dealer will replace, free of charge, any part or parts found upon examination by the factory at McDonough, Georgia, to be defective in material or workmanship or both.

All transportation costs incurred by the purchaser in submitting material to an authorized **SNAPPER** dealer for replacement under this warranty must be paid by the purchaser.

This warranty does not apply to certain transmissions, to engines and their components, and batteries, as these items are warranted separately. This warranty does not apply to parts that have been damaged by accident, alteration, abuse, improper lubrication, normal wear, or other cause beyond the control of **SNAPPER**. This warranty does not cover any machine or component part that has been altered or modified changing safety, performance, or durability.

Batteries have a one (1) year warranty period with free replacement if required for one (1) year from the original purchase date. **SNAPPER** will not be responsible for any installation cost incurred. The battery warranty only covers original equipment batteries and does not cover damage to the battery or machine caused by neglect or abuse, destruction by fire, explosion, freezing, overcharging, improper maintenance, or use of improper electrolyte.

There is no other express warranty.

### **DISCLAIMER OF WARRANTY**

**Implied warranties, including those of merchantability and fitness for a particular purpose, are limited to two (2) years from purchase date for the original purchaser's residential or other non-commercial use, and ninety (90) days from purchase for the original purchaser's commercial, rental or other non-residential use, and to the extent permitted by law, any and all implied warranties are excluded. This is the exclusive remedy. Liabilities for consequential damages, under any and all warranties are excluded.**

**Some states do not allow limitations on how long an implied warranty lasts, or do not allow the exclusion or limitation of incidental or consequential damages, so the above limitation or exclusion may not apply to you.**

This warranty gives you specific legal rights, and you may also have other rights which vary from state to state.

**WARNING: THE USE OF REPLACEMENT PARTS OTHER THAN GENUINE SNAPPER PARTS MAY IMPAIR THE SAFETY OF SNAPPER PRODUCTS AND WILL VOID ANY LIABILITY AND WARRANTY BY SNAPPER ASSOCIATED WITH THE USE OF SUCH PARTS.**

**IMPORTANT:** Please fill out the attached **SNAPPER** Product Registration Card immediately and mail to:  
**Snapper's Product Registration Center, P.O. Box 1379, McDonough, Georgia 30253**

# SNAPPER PRODUCT REGISTRATION FORM

**IMPORTANT: KEEP THIS INFORMATION FOR YOUR PERSONAL RECORDS  
(Complete the following information on your Snapper purchase)**

**Model Number** \_\_\_\_\_

**Serial Number** \_\_\_\_\_

**Date of Purchase** \_\_\_\_\_

**Retailer** \_\_\_\_\_

**Retailer's Phone Number** \_\_\_\_\_

**It is very important that you register your purchase with Snapper to ensure warranty coverage. Please mail your product registration card to:**

**Snapper at P.O. Box 777, McDonough, Georgia 30253.**

**Or you may register on line at [www.snapper.com](http://www.snapper.com).**

**You can contact us at our web site or if you would like to speak with a Customer Service Representative. Call us at the Snapper Customer Relations Center. For faster service please have your Serial Number and Model Number available.**

**Call the Snapper Customer Relations Center at 1-800-935-2967.**

**Eastern Standard Time**

**Monday through Friday from 8am to 6pm.**

**Saturday from 9am to 1pm.**

PRIMARY MAINTENANCE

# SNAPPER®

## vs. DIRT!

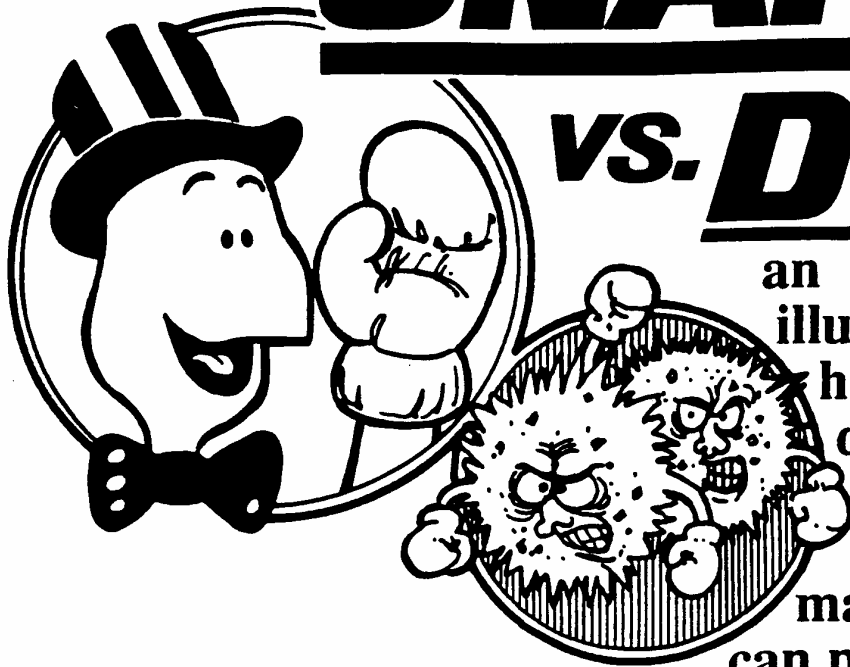

an illustration of how dirt can damage your engine & how reasonable maintenance can protect it!

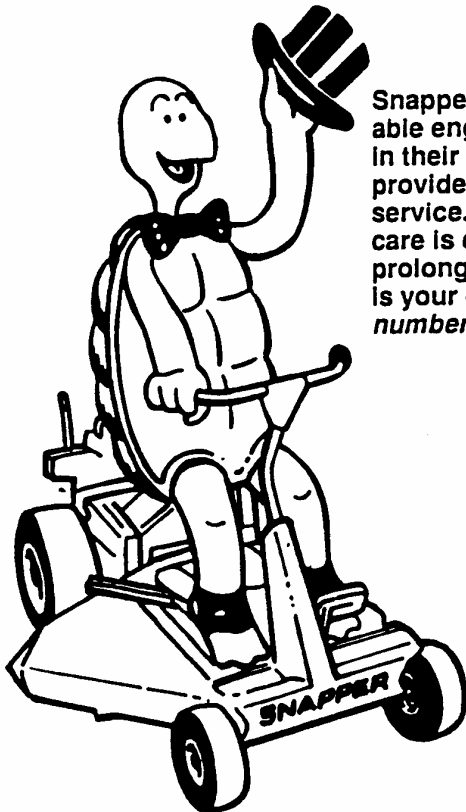

Snapper uses the best available engines and components in their products in order to provide long, satisfactory service. However, proper care is essential in prolonging engine life. Dirt is your engine's *enemy number 1!*

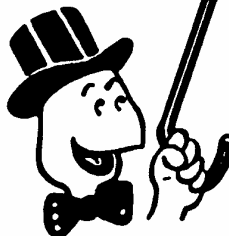

The engine on your Snapper product spends its entire life operating close to the ground at high speed creating a virtual storm of dust and dirt!

## PRIMARY MAINTENANCE

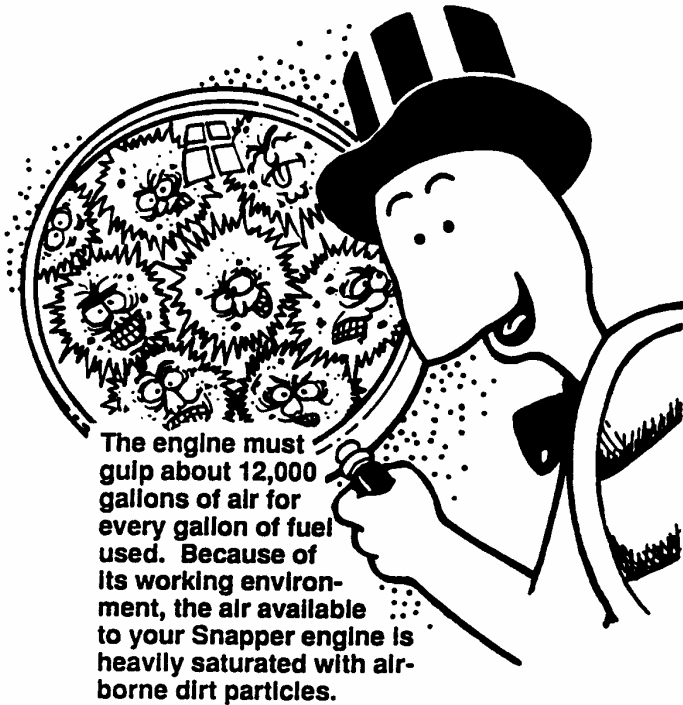

The engine must gulp about 12,000 gallons of air for every gallon of fuel used. Because of its working environment, the air available to your Snapper engine is heavily saturated with airborne dirt particles.

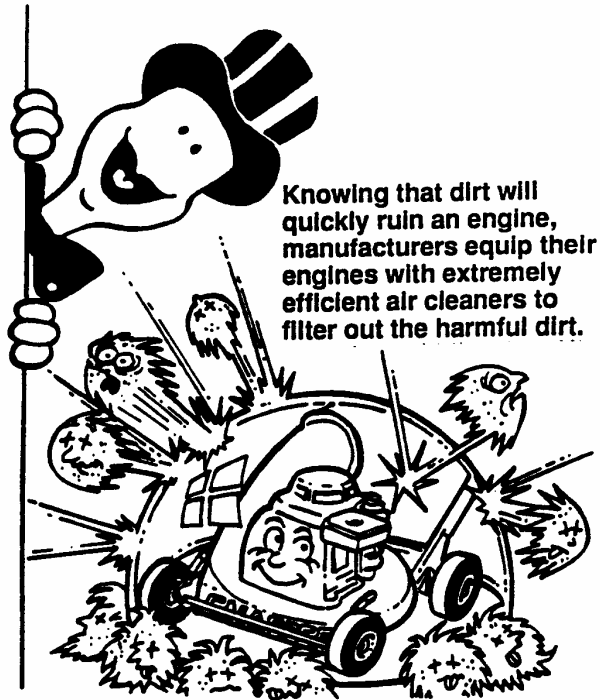

Knowing that dirt will quickly ruin an engine, manufacturers equip their engines with extremely efficient air cleaners to filter out the harmful dirt.

As the dirt particles are stopped, they build up and begin to clog the outside of the filter. This reduces the amount of air available to the engine and causes an over-rich fuel mixture which results in the following adverse effects:

An Improperly serviced, dirt clogged air cleaner will:

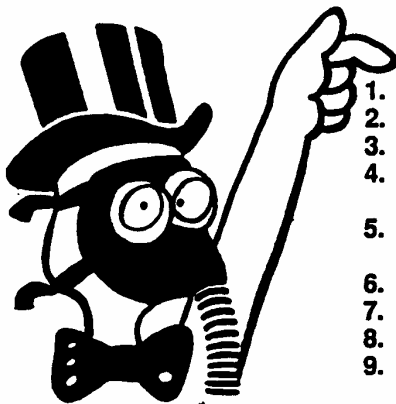

1. Increase fuel consumption
2. cause power loss
3. result in hard starting
4. create smoke from unburned fuel
5. produce carbon build-up internally
6. foul spark plug electrodes
7. score cylinder walls
8. burn valves
9. wear out the engine prematurely
10. COST YOU MONEY!

Damage caused by a poorly serviced air cleaner is not covered under the engine warranties. So, save yourself unnecessary expenses and undue aggravation by keeping the air cleaner properly serviced at the intervals specified in the engine owner's manual.

It doesn't take long to service an air cleaner. Follow the specific instructions in the engine owner's manual for the type filter used. Prevent dirt from falling into the carburetor intake when servicing your air cleaner. Make sure components are installed in correct sequence after servicing to prevent unfiltered air from entering the engine. Some servicing hints on several common types are:

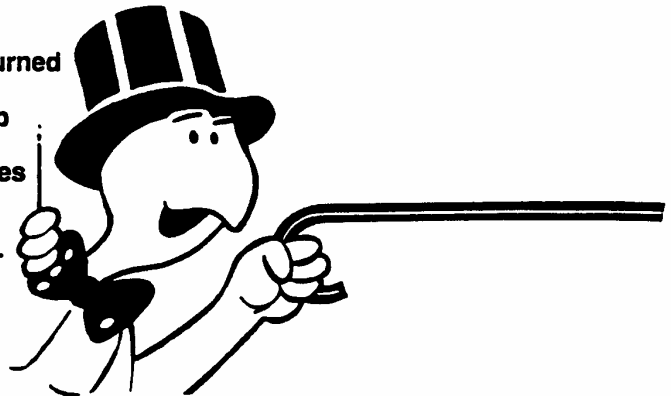



# PRIMARY MAINTENANCE

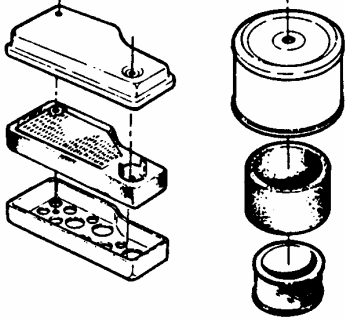

Generally, wash foam-type filters in a dishwashing detergent and water solution. Rinse and wring dry, then saturate with oil and squeeze out excess. *Failure to re-oil this type filter will ruin the engine.*

Clean paper elements by tapping lightly. Blowing with air will rupture paper elements.

Use a flashlight to detect clogged or torn paper elements - replace if damaged in any way.



Air is also needed to keep your engine cool. Dirt, dust & debris build up to restrict and clog cooling air intake screens and fins. Clean screens and fins at frequent intervals. The engine blower housing and shrouds should be removed at least once each season or more often under dry, dusty conditions for a thorough cleaning of fins.

Failure to keep external surfaces clean not only presents fire hazards, but causes overheating and resulting engine damages such as:

1. distorted valve guides
2. sticking valves
3. scuffed, scored cylinder walls
4. overspeeding
5. loss of power
6. complete failure of engine.

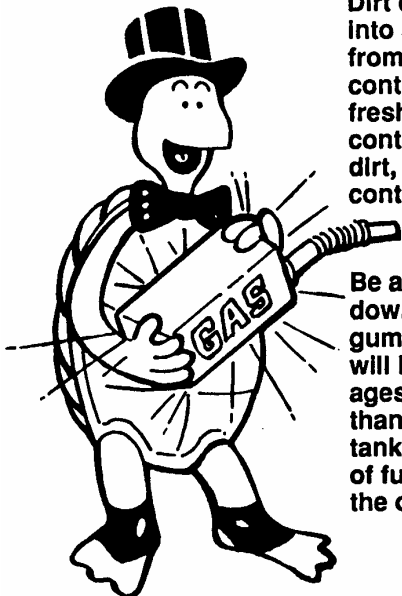
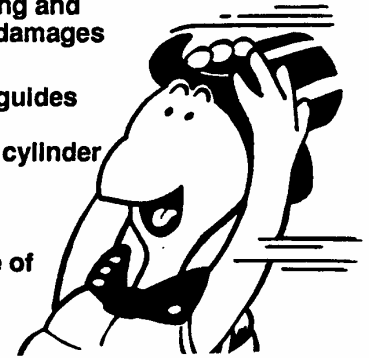

Dirt can also be introduced into an engine in dirty fuel from a contaminated container. Always use clean fresh fuel from a clean container to guard against dirt, sludge and water contamination.

Be aware that fuel breaks down in storage and forms gummy compounds which will block carburetor passages. Never use fuel more than 3 months old. Drain tank then run the engine out of fuel before storing during the off-season.

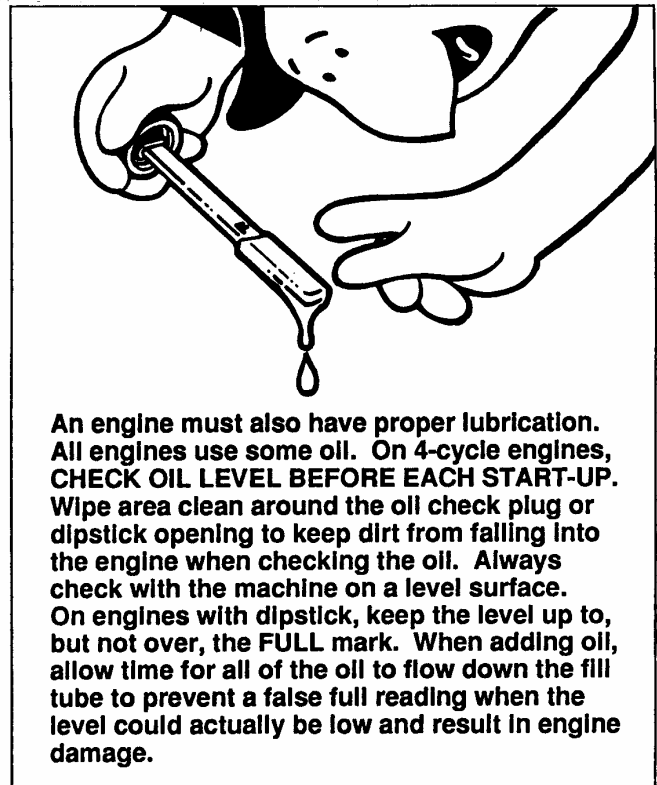

An engine must also have proper lubrication. All engines use some oil. On 4-cycle engines, **CHECK OIL LEVEL BEFORE EACH START-UP.** Wipe area clean around the oil check plug or dipstick opening to keep dirt from falling into the engine when checking the oil. Always check with the machine on a level surface. On engines with dipstick, keep the level up to, but not over, the **FULL** mark. When adding oil, allow time for all of the oil to flow down the fill tube to prevent a false reading when the level could actually be low and result in engine damage.

## PRIMARY MAINTENANCE

On 4-cycle engines with an oil level plug, don't be fooled into thinking the engine has sufficient lubricating oil if you can see "some" oil in the opening - the level should always be brought up to the point of overflowing at the top of the fill hole.

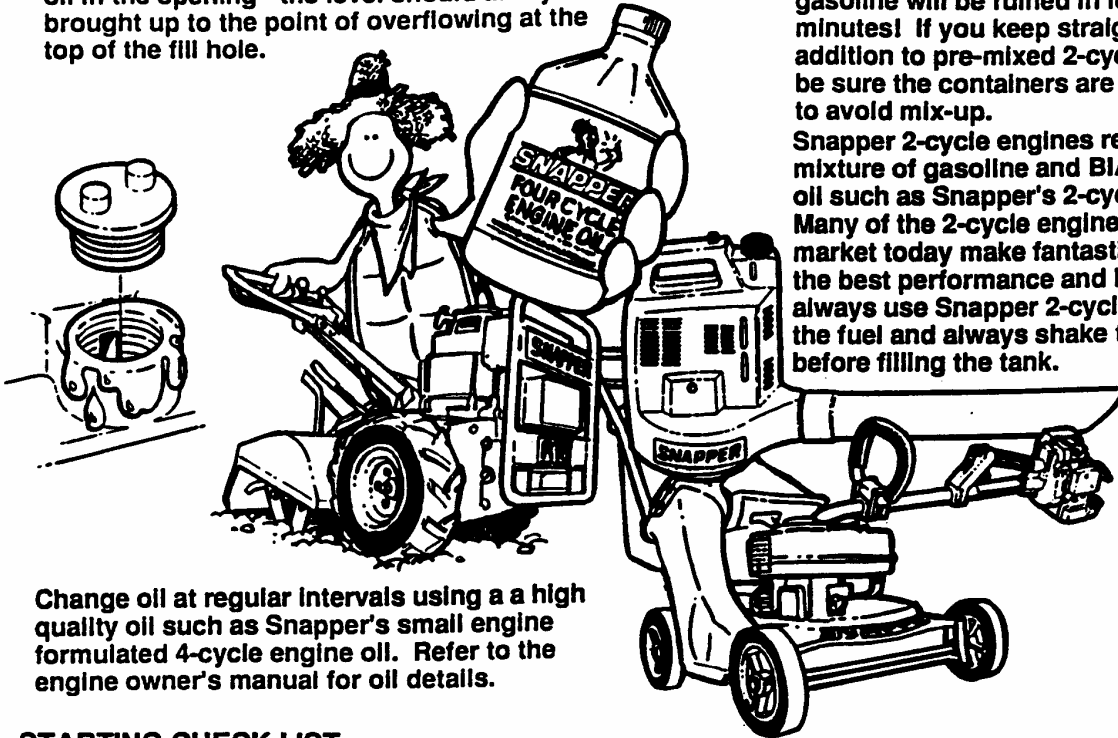

On 2-cycle engines, lubrication must be provided by an exact mixture of gasoline and 2-cycle air-cooled engine oil. A 2-cycle engine that is mistakenly run on straight gasoline will be ruined in less than 5 minutes! If you keep straight gasoline in addition to pre-mixed 2-cycle engine fuel, be sure the containers are clearly marked to avoid mix-up.

Snapper 2-cycle engines require a 32 to 1 mixture of gasoline and BIA certified TC-W oil such as Snapper's 2-cycle engine oil. Many of the 2-cycle engine oils on the market today make fantastic claims, but for the best performance and long engine life, always use Snapper 2-cycle oil. Pre-mix the fuel and always shake the container before filling the tank.

Change oil at regular intervals using a high quality oil such as Snapper's small engine formulated 4-cycle engine oil. Refer to the engine owner's manual for oil details.

### STARTING CHECK LIST

- |                              |  |
|------------------------------|--|
| 1. Engine Oil                | <ul style="list-style-type: none"> <li>• To full level (4-cycle)</li> <li>• Properly mixed with gas (2 cycle)</li> </ul>             |
| 2. Air Cleaner               | <ul style="list-style-type: none"> <li>• Clean and properly serviced</li> <li>• Full fresh clean gasoline</li> </ul>                 |
| 3. Fuel Tank                 | <ul style="list-style-type: none"> <li>• Fuel valve open</li> <li>• Cap vent open</li> <li>• Inline filter clean</li> </ul>          |
| 4. Choke                     | <ul style="list-style-type: none"> <li>• Operating properly</li> </ul>   |
| 5. Primer (on some engines)  | <ul style="list-style-type: none"> <li>• Used properly</li> </ul>  |
| 6. Safety Interlock Switches | <ul style="list-style-type: none"> <li>• In proper position</li> <li>• All wires properly connected</li> </ul>                       |
| 7. Switch & Blade Control    | <ul style="list-style-type: none"> <li>• Switch On</li> <li>• Blade control properly positioned on walk mower</li> </ul>             |
| 8. Spark plug                | <ul style="list-style-type: none"> <li>• Wire connected</li> <li>• Good connection</li> <li>• Start position</li> </ul>              |
| 9. Throttle control          |  |
| 10. Blade                    | <ul style="list-style-type: none"> <li>• Properly installed and torqued</li> <li>• Sharpened</li> </ul>                              |
| 11. Muffler                  | <ul style="list-style-type: none"> <li>• Good condition</li> <li>• Not clogged</li> <li>• Grass &amp; leaves cleaned away</li> </ul> |

Read and follow all safety instructions in safety booklets and manuals.

Keep in mind that dirt is your engine's *enemy* #1 both internally and externally! Internally, dirt will quickly ruin an engine and externally it will cause overheating and resulting internal damages. Damage caused by improper lubrication, poor air cleaner service or overheating due to dirt cannot be covered under warranty.

It only takes a few moments to service the engine (and equipment) on a routine basis but the rewards will be a quick starting, responsive engine that will provide long satisfactory service with minimum maintenance cost. The prestart checklist in the next column and instructions in your Snapper Operator's Manual are designated to help you keep your Snapper in top operating condition with minimum effort!





## Safety Instructions & Operator's Manual for

# SNAPPER®

## 26" STEEL DECK WALK MOWERS SERIES 0

### IMPORTANT

Snapper products are built using engines that meet or exceed all applicable emissions requirements on the date manufactured. The labels on those engines contain very important emissions information and critical safety warnings. Read, Understand, and Follow all warnings and instructions in this manual, the engine manual, and on the machine, engine and attachments. If you have any questions about your Snapper product, contact your local authorized Snapper dealer or contact Snapper Customer Service at Snapper, McDonough, GA. 30253. Phone: (1-800-935-2967).



### WARNING

BATTERY POSTS, TERMINALS AND RELATED ACCESSORIES CONTAIN LEAD AND LEAD COMPOUNDS, CHEMICALS KNOWN TO THE STATE OF CALIFORNIA TO CAUSE CANCER AND BIRTH DEFECTS OR OTHER REPRODUCTIVE HARM. WASH HANDS AFTER HANDLING.



### WARNING

ENGINE EXHAUST, SOME OF ITS CONSTITUENTS, AND CERTAIN VEHICLE COMPONENTS CONTAIN OR EMIT CHEMICALS KNOWN TO THE STATE OF CALIFORNIA TO CAUSE CANCER OR OTHER REPRODUCTIVE HARM.

**SNAPPER**® McDonough, GA., 30253 U.S.A.