

# Safety Instructions & Operator's Manual for **SNAPPER**<sup>®</sup>

## OUT FRONT Z-RIDER HYDRO DRIVE SERIES 0

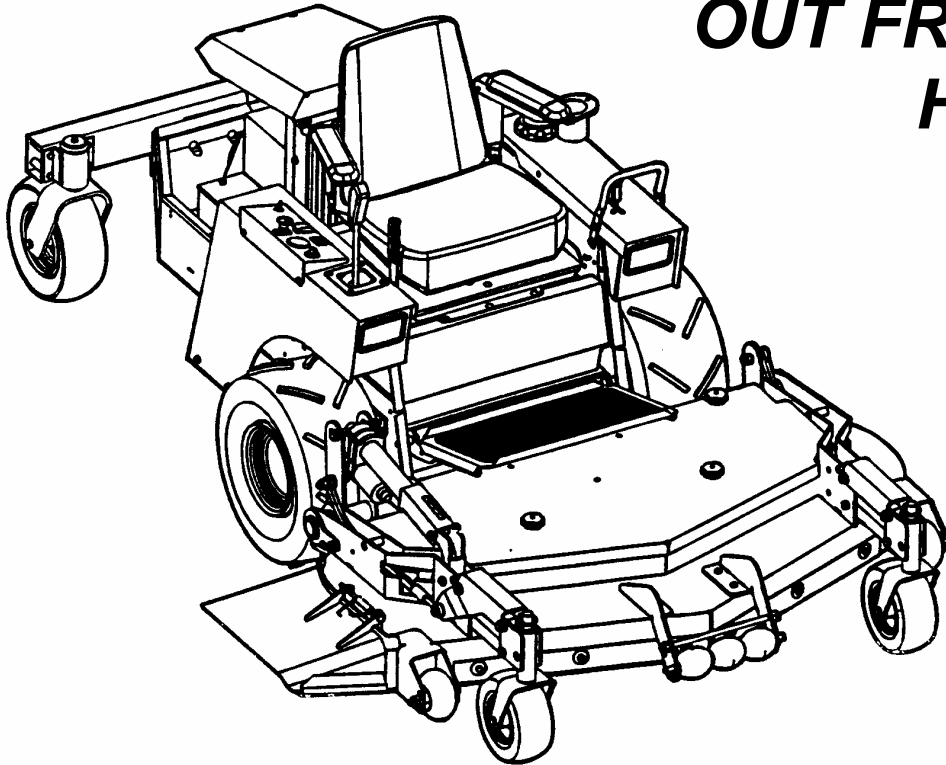

<b>POWER UNIT MODELS</b>	
EZF2100DKU	
EZF2300GKU	

<b>MOWER UNIT MODELS</b>	
EZF5200M	EZF6100M

MODEL NUMBER EXPLANATION						
E	Z	F	21	00	D	KU
EXPORT MODEL	DRIVE SYSTEM TYPE	MOWER ORIENTATION	ENGINE HP	POWER UNIT	ENGINE MODEL	ENGINE TYPE
						SERIES DESIGNATION
E – Export Model	Z – Zero Turning – Hydro Drive	F – Out Front Mower	21 – Engine Horse Power 23 – Engine Horse Power	00 – Series Designation	D – Diesel Fuel Engine G – Gasoline Fuel Engine	KU – Kubota Engine
MOWER UNIT						
Z – Zero Turning – Hydro Drive	F – Out Front Mower	52 – Mower Cutting Width 61 – Mower Cutting Width	00 – Series Designation	M – Mower Deck		

Thank you for buying a SNAPPER Product! Before operating your machine, read this manual carefully and pay particular attention to the "IMPORTANT SAFETY INSTRUCTIONS" on Pages 2 & 3. Remember that all power equipment can be dangerous if used improperly. Also keep in mind that SAFETY requires careful use in accordance with the operating instructions and common sense!

**SNAPPER**<sup>®</sup> McDonough, GA., 30253 U.S.A.



# IMPORTANT SAFETY INSTRUCTIONS



**WARNING:** This powerful cutting machine is capable of amputating hands and feet and can throw objects that can cause injury and damage! Failure to comply with the following **SAFETY** instructions could result in serious injury or death to the operator or other persons. The owner of the machine must understand these instructions and must allow only persons who understand these instructions to operate machine. Each person operating the machine must be of sound mind and body and must not be under the influence of any substance, which might impair vision, dexterity or judgment. If you have any questions pertaining to your machine which your dealer cannot answer to your satisfaction, call or write the Customer Service Department at SNAPPER, McDonough, Georgia 30253. Phone: (1-800-935-2967).

## PROTECTION FOR CHILDREN

Tragic accidents can occur if the operator is not alert to the presence of children. Children are often attracted to the machine and the mowing activity. Never assume that children will remain where you last saw them.

1. **KEEP** children out of the mowing area and under the watchful care of a responsible adult.
2. **DO NOT** allow children in yard when machine is operated (even with the blades OFF).
3. **DO NOT** allow children or others to ride on machine or on attachments (even with the blade OFF). They may fall and be seriously injured.
4. **DO NOT** allow pre-teenage children to operate machine.
5. **ALLOW** only adults or responsible teenagers with mature judgment under close adult supervision to operate machine.
6. **DO NOT** operate blades in reverse. **STOP BLADES.** **LOOK** and **SEE** behind and down for children, pets and hazards before and while backing.
7. **USE EXTRA CARE** when approaching blind corners, shrubs, trees, or other objects that may obscure vision.

## PROTECTION AGAINST TIPOVERS

Slopes are a major factor related to loss-of-control and tip-over accidents, which can result in severe injury or death. All slopes require extra **CAUTION**. If you cannot back up the slope or if you feel uneasy on the slope, **DO NOT** mow it. Use extra care with grass catchers or other attachments; these affect the handling and the stability of the machine.

1. **DO NOT** operate machine on slopes exceeding 15 degrees (27% grade).
2. Exercise **EXTREME CAUTION** on slopes above 10 degrees (18% grade). Turn blades **OFF** when traveling uphill. Use a slow speed and avoid sudden or sharp turns.
3. **DO NOT** operate machine back and forth across face of slopes. Operate up and down. Practice on slopes with blades off.

## PROTECTION AGAINST TIPOVERS

(Continued From Previous Column)

4. **AVOID** uphill starts. If machine stops going uphill or tires lose traction, turn blades **OFF** and back slowly down the slope.
5. **STAY ALERT** for holes and other hidden hazards. Tall grass can hide obstacles. Keep away from ditches, washouts, culverts, fences and protruding objects.
6. **KEEP A SAFE DISTANCE** (at least 3 feet) away from edge of ditches and other drop offs. The machine could turn over if an edge caves in.
7. Always begin forward motion slowly and with caution.
8. Use weights or a weighted load carrier in accordance with instructions supplied with a grass catcher. **DO NOT** operate machine on slopes exceeding 10 degrees (18% grade) when equipped with grass catcher.
9. **DO NOT** put your foot on the ground to try to stabilize the machine.
10. **DO NOT** operate machine on wet grass. Reduced traction could cause sliding.
11. **DO NOT** operate machine under any condition where traction, steering or stability is doubtful.
12. Operator Protective Structures are available for this machine through your local Snapper dealer.

## PREPARATION

1. Read, understand and follow instructions and warnings in this manual and on the machine, engine and attachments. Know the controls and the proper use of the machine before starting.
2. Only mature, responsible persons shall operate the machine and only after proper instruction.
3. Data indicates that operators age 60 and above, are involved in a large percentage of mower-related injuries. These operators should evaluate their ability to operate the mower safely enough to protect themselves and others from serious injury.
4. Handle fuel with extra care. Fuels are flammable and vapors are explosive. Use only an approved fuel container. **DO NOT** remove fuel cap or add fuel with engine running. Add fuel outdoors only with engine stopped and cool. Clean spilled fuel from machine. **DO NOT** smoke.



# IMPORTANT SAFETY INSTRUCTIONS



## PREPARATION

(Continued From Previous Page)

5. Practice operation of machine with **BLADES OFF** to learn controls and develop skills.
6. Check the area to be mowed and remove all objects such as toys, wire, rocks, limbs and other objects that could cause injury if thrown by blades or interfere with mowing.
7. Keep people and pets out of mowing area. Immediately, **STOP** blades, **STOP** engine, and **STOP** machine if anyone enters the area.
8. Check shields, deflectors, switches, blade controls and other safety devices frequently for proper operation and location.
9. Make sure all safety decals are clearly legible. Replace if damaged.
10. Protect yourself when mowing and wear safety glasses, long pants and substantial footwear.
11. Know how to **STOP** blades and engine quickly in preparation for emergencies.
12. Use extra care when loading or unloading the machine into a trailer or truck.
13. Check grass catcher components frequently for signs of wear or deterioration and replace as needed to prevent injury from thrown objects going through weak or worn spots.

## OPERATION

1. Mount and dismount machine from left side.
2. Start engine from operator's seat, if possible. Make sure blades are **OFF** and parking brake is set.
3. **DO NOT** leave machine with engine running. Stop engine. Stop blades. Set brake. Remove key.
4. **DO NOT** operate machine unless properly seated with feet on feet rests or pedal(s).
5. **STOP BLADES** and **ENGINE** and make sure blades have stopped before removing grass catcher or unclogging mower to prevent loss of fingers or hand.
6. Blades must be **OFF** except when cutting grass. Set blades in highest position when mowing over rough ground.
7. Keep hands and feet away from rotating blades underneath deck. **DO NOT** place foot on ground while **BLADES** are **ON** or machine is in motion.
8. **DO NOT** operate machine without entire grass catcher or guards in place. **DO NOT** point discharge at people, passing cars, windows or doors.
9. Slow down before turning.
10. Watch out for traffic when near or crossing roadways.
11. **STOP** engine immediately after striking an obstruction. Inspect machine and repair damage before resuming operation.

## OPERATION

(Continued From Previous Column)

12. Mow only in daylight or with good artificial light.
13. Move motion control levers **SLOWLY** to maintain control during speed and directional changes.
14. Exercise **CAUTION** when pulling loads. **DO NOT** pull loads greater than 300 pounds. Avoid jack knifing. **DO NOT** turn sharply.
15. **DO NOT** operate engine in enclosed areas. Engine exhaust gases contain carbon monoxide, a deadly poison.

## MAINTENANCE

1. **DO NOT** store machine or fuel container inside where fumes may reach an open flame, spark or pilot light such as in a water heater, furnace, clothes dryer or other gas appliance. Allow engine to cool before storing machine in an enclosure. Store fuel container out of the reach of children in a well ventilated, unoccupied building.
2. Keep engine free of grass, leaves or excess grease to reduce fire hazard and engine overheating.
3. When draining fuel tank, drain fuel into an approved container outdoors and away from open flame.
4. Check brakes frequently; adjust, repair or replace as needed.
5. Keep all bolts, nuts and screws properly tight. Check that all cotter pins are in proper position.
6. Always provide adequate ventilation when running engine. Engine exhaust gases contain carbon monoxide, an odorless and deadly poison.
7. Disconnect negative (black) cable from battery before performing maintenance or service. Cranking engine could cause injury.
8. **DO NOT** work under machine without safety blocks.
9. Service engine and make adjustments only when engine is stopped. Remove spark plug wire(s) from spark plug(s) and secure wire(s) away from spark plug(s).
10. **DO NOT** change engine governor speed settings or overspeed engine.
11. Lubricate machine at intervals specified in manual to prevent controls from binding.
12. Mower blades are sharp and can cut. Wrap the blades or wear heavy leather gloves and use **CAUTION** when handling them.
13. **DO NOT** test for spark by grounding spark plug next to spark plug hole; spark plug could ignite gas exiting engine.
14. Have machine serviced by an authorized **SNAPPER** dealer at least once a year and have the dealer install any new safety devices.
15. Use only genuine **SNAPPER** replacement parts to assure that original standards are maintained.

# TABLE OF CONTENTS

<b>IMPORTANT SAFETY INSTRUCTIONS</b> .....	<b>2-3</b>
<b>TABLE OF CONTENTS</b> .....	<b>4</b>
<b>SECTION 1 - FAMILIARIZATION</b> .....	<b>5</b>
SYMBOLS .....	6-8
<b>SECTION 2 - OPERATING INSTRUCTIONS</b> .....	<b>9-13</b>
Pre-start Checklist .....	9
Starting & Stopping Engine, Blades & Parking Brake .....	10-12
Starting & Stopping Mower Blades .....	11
Parking Brake .....	12
Cutting Height Adjusting .....	12
Driving & Stopping Machine .....	13
<b>SECTION 3 - MAINTENANCE INSTRUCTIONS</b> .....	<b>14-18</b>
Change Engine Oil.....	14
Check Mower Blade .....	14
Check Mower Drive Belt.....	15
Check Belt Tension .....	15
Service – After every 25 Hours (Engine).....	15
Service – After every 25 Hours (Mower Components).....	15
Mower Blade Spindle Lubrication .....	15
Mower Deck Linkage Lubrication .....	15
Front Wheel Bearings Lubrication.....	16
Transaxle Lubrication.....	16
Power Transfer Shaft Lubrication.....	16
Other Lubrication.....	16
Before Operating Mower .....	16
Annually - End of Season Service .....	16-17
Fuel Filter Replacement .....	17
Deck Removal .....	17-18
Power Transfer Shaft Removal .....	18
<b>SECTION 4 - ADJUSTMENTS AND REPAIR</b> .....	<b>19-25</b>
Neutral Position Adjustments .....	19
Mower Deck Adjustment (Levelness).....	19-20
Parking Brake Adjustment.....	20
Engine Adjustments & Repair.....	20
Mower Blade Replacement .....	20-21
Blade Sharpening .....	21
Mower Drive Belt, Engine Belt & Hydro Pump Belt Removal & Replacement .....	22
Battery Removal .....	23
Battery Installation .....	23
Battery Service & Charging .....	23-24
Battery Testing.....	24
New Battery Preparation.....	24
Mower Spindles (Field Serviceable Spindles) Bearing Replacement.....	25
<b>TROUBLESHOOTING</b> .....	<b>26-27</b>
<b>SERVICE SCHEDULE</b> .....	<b>28</b>
Maintenance/Replacement Parts .....	28
<b>WARRANTY</b> .....	<b>29</b>

## IMPORTANT

NOTICE: Operator Protective Structures are available as optional kits for the Mid-Mount and Out-Front Z-Rider machines. These structures, when installed and used properly can offer additional security to the operator against serious injury in the event of a tip over accident. Operator Protective Structures may be required by local ordinances. Discuss your mowing application and ordinances with your local Snapper Dealer.

**IMPORTANT: DIESEL AND GAS UNITS LOOK VERY SIMILIAR. DO NOT PUT GAS IN DIESEL MACHINE OR DIESEL IN GAS MACHINE. ENGINE DAMAGE MAY RESULT.**

# Section 1 – FAMILIARIZATION

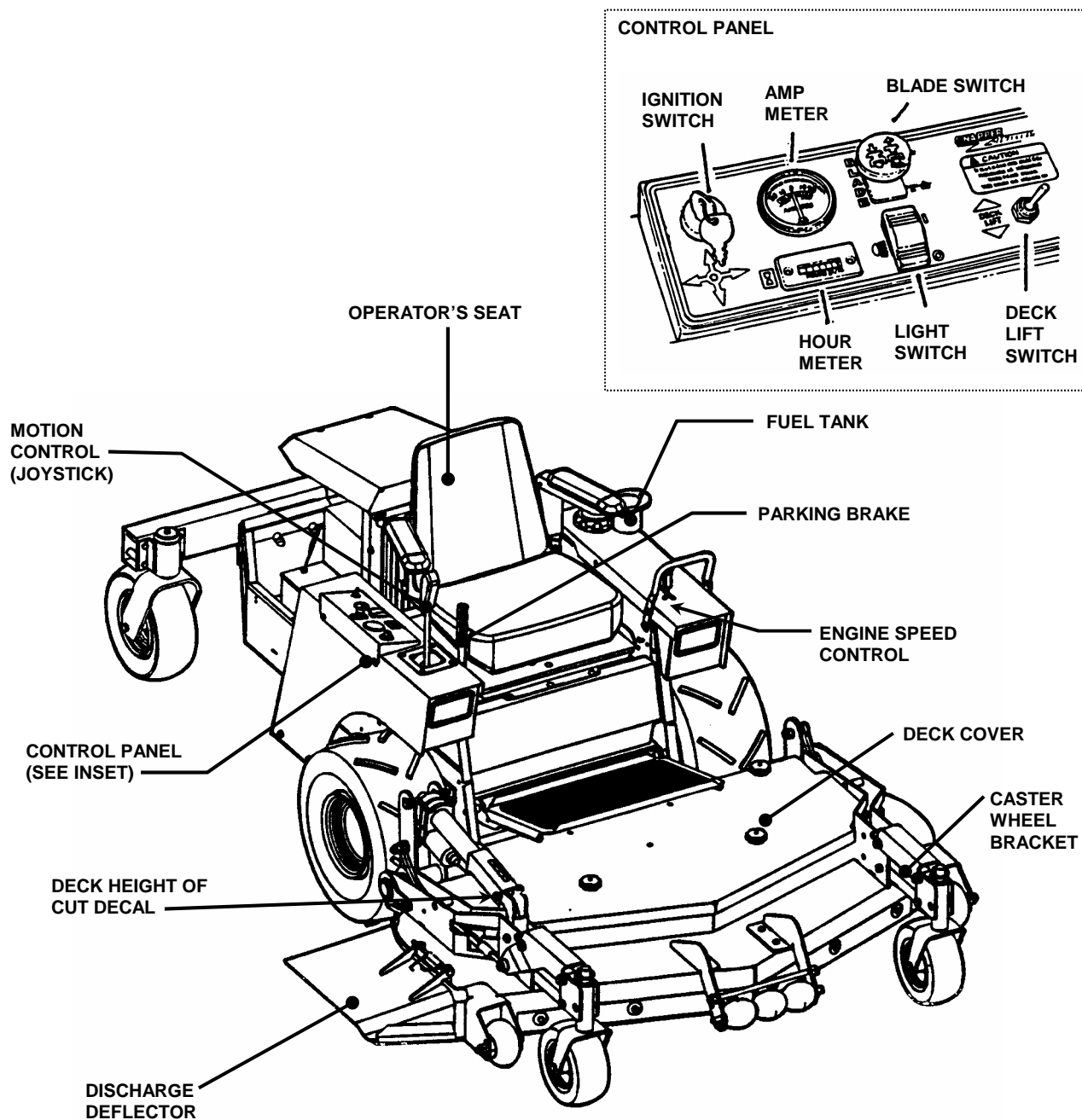

FIGURE 1.1

## 1.1 INTRODUCTION

This manual has been prepared for the operator's of the SNAPPER OUT FRONT Z-RIDER. Its purpose, aside from recommending standard operating procedures and routine service requirements, is to promote SAFETY through the use of accepted operating practices. Read, Understand and Follow the IMPORTANT SAFETY INSTRUCTIONS on Page 2 and 3 of this manual and All SAFETY messages on the OUT FRONT Z-RIDER and its attachments before operating. SNAPPER recommends returning the OUT FRONT Z-RIDER to an authorized SNAPPER dealer annually for inspection and addition of any new devices which might upgrade the safety of the mower.

## 1.2 NOMENCLATURE

The nomenclature information above, Figure 1.1, shows the essential parts of the SNAPPER OUT FRONT Z-RIDER. It is recommended that all operator's of this equipment become thoroughly familiar with the controls, components, and operation of this machine before operating. Specific details involving the engine are found in the separate engine owner's manual. Study these manuals before operating and keep both handy for future reference. For the nearest SNAPPER dealer in your area, check the yellow pages under the heading LAWN MOWERS. For engine parts and service, look for the engine manufacturer's dealers under the heading, ENGINES - gasoline.

# SYMBOLS



Hearing protection required during machine operation.



Sound Power Level produced by machine and cutter deck - Lwa 105.



PARKING BRAKE CONTROL LEVER - Push control forward to disengage (unlock/off). Pull control rearward to engage (lock/on).

IMPORTANT: Parking Brake must be engaged (locked) to start engine.

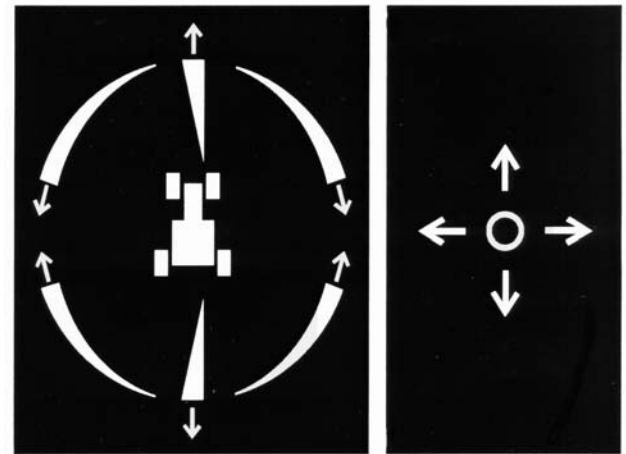

MACHINE MOTION CONTROL - Single lever, multi-directional & continuously variable, controls direction of motion & speed of motion. Forward displacement of control produces forward motion. Rearward displacement of control produces rearward motion. Increased control displacement produces increased speed of motion.

ENGINE STOP (OFF)

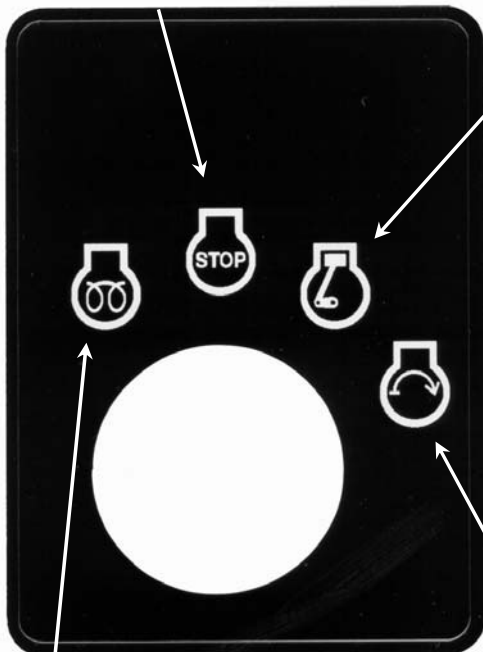

ENGINE RUN (ON)

ENGINE START

ENGINE GLOW PLUG PRE-HEAT

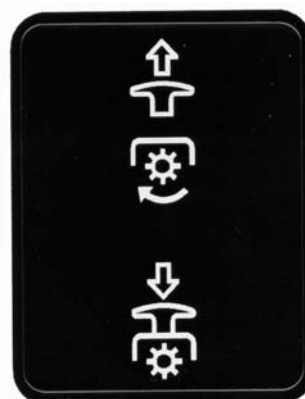

MOWER BLADE CONTROL SWITCH - Pull switch up (ON) to engage blade. Push switch down (OFF) to disengage blade.

IMPORTANT: Mower Blade Control Switch must be in (OFF) disengaged position to start engine.

# SYMBOLS



ENGINE SPEED CONTROL  
RABBIT - FAST  
TURTLE - SLOW



CUTTING HEIGHT CONTROL SWITCH -  
Move switch in direction of plus symbol to increase cutting height/  
Move switch in direction of minus symbol to decrease cutting height.



DIESEL FUEL ONLY

Read and understand all manuals and instructions furnished with the machine.

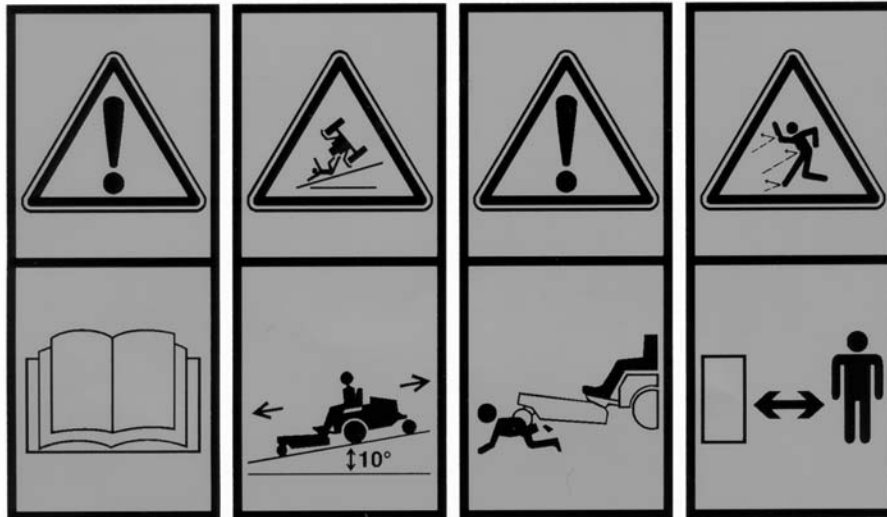

Keep a safe distance from the machine. Always clear the mowing area of all objects that could cause injury if thrown by blades.

DO NOT operate machine on slopes greater than 10 degrees (17%). DO NOT mow across face of slope.

Keep children and others out of mowing area and under the watchful care of a responsible adult. Never assume children will stay where you last saw them. Look down and behind machine before and while backing. DO NOT operate blades in reverse.

# SYMBOLS

DO NOT perform any service, maintenance, adjustments or repairs with the engine running. STOP engine. STOP blades. Engage Parking Brake. REMOVE key. Read Manual.

DO NOT touch or approach machine components until all motion has completely stopped.

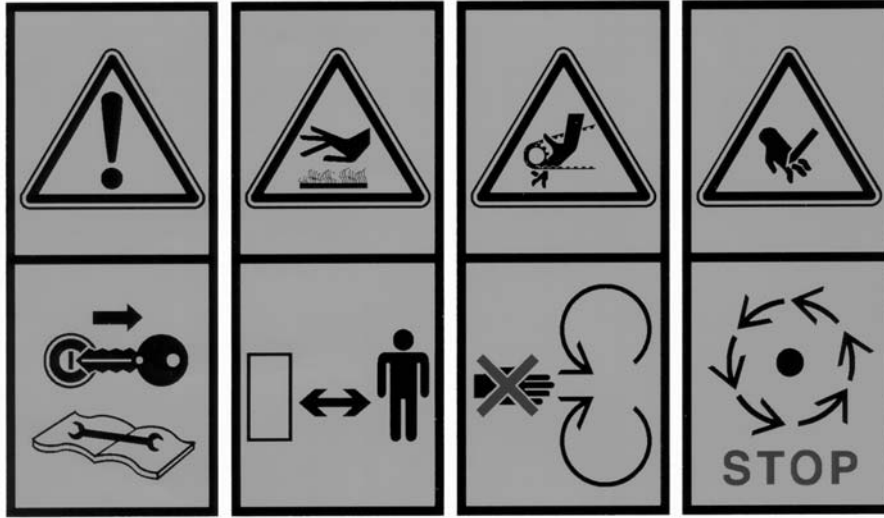

HOT SURFACE! Stay clear.

DO NOT open or remove safety shields while engine is running. DO NOT operate machine unless all guards and shields are in place and securely fastened.

DO NOT open or remove guards or shields while engine is running. STOP engine. Allow all motion to completely stop before approaching.

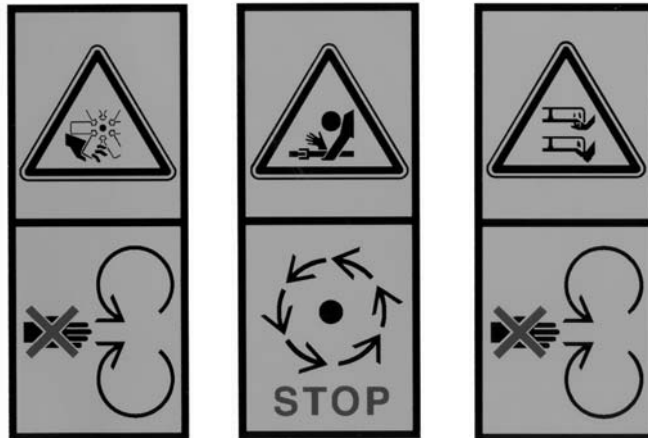

DO NOT approach mower while engine is running. STOP engine. Allow all motion to completely stop before approaching.

DO NOT open or remove guards or shields while engine is running. STOP engine. Allow all motion to completely stop before approaching.



## Section 2 - OPERATING INSTRUCTIONS

### 2.1 PRE-START CHECK LIST

Make the following checks and perform the service required before each start-up.

- 2.1.1. Check tires and add or release air as needed to bring pressure in drive tires to: 12 psi (Turf Type Tires), 5 psi (All Terrain Type Tires) and 25 psi in rear caster tires. Pressure in front deck caster wheels should be 25 psi.
- 2.1.2. Check guards, deflectors and covers to make sure all are in place and securely tightened.
- 2.1.3. Check engine oil and add oil as needed to bring level up to the FULL mark. Refer to engine owner's manual for oil specifications. See Figure 2.1.

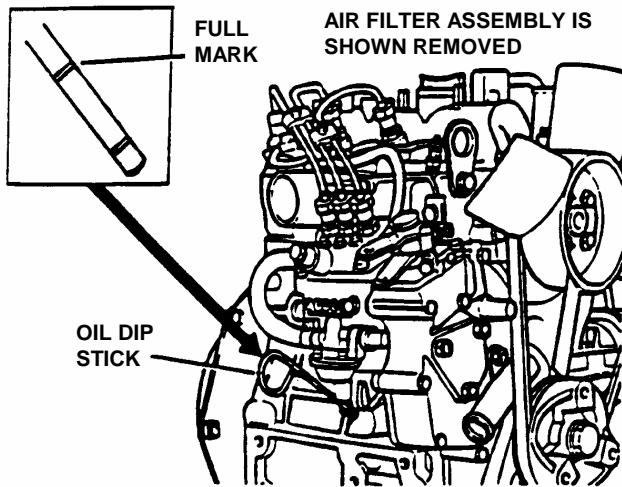
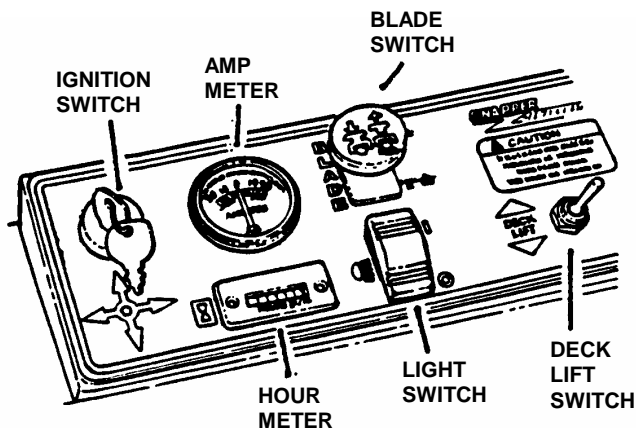

FIGURE 2.1

- 2.1.4. Check Blade switch to insure it works freely. Switch is pulled "OUT" for blade engagement or pushed back "IN" for blade disengagement. See Figure 2.2. **IMPORTANT:** Disengagement stops blades.



**BLADE SWITCH:**  
PULL "OUT" TO ENGAGE BLADE.  
PUSH "IN" TO DISENGAGE BLADE.

FIGURE 2.2

- 2.1.5. Clean exterior surfaces of cutting deck and engine of any accumulation of dirt, grass, oil, etc. Keep engine radiator air intake screen and cooling fins clear at all times. Check often in dry operating conditions.
- 2.1.6. Add fresh fuel to tank of the Out Front Z-Rider outside where fumes can safely dissipate. Make sure fuel filler cap is tight. Refer to engine owner's manual for fuel specifications.
- 2.1.7. **COLD ENGINE ONLY** - Check engine coolant (antifreeze/water) and add coolant in the reserve tank as needed to bring level up to the FULL mark. Refer to engine owner's manual for coolant ratio specifications. See Figure 2.3.

**WARNING**  
**DO NOT** remove cap from radiator when engine and coolant are hot. Coolant is pressurized. Severe burns could result.

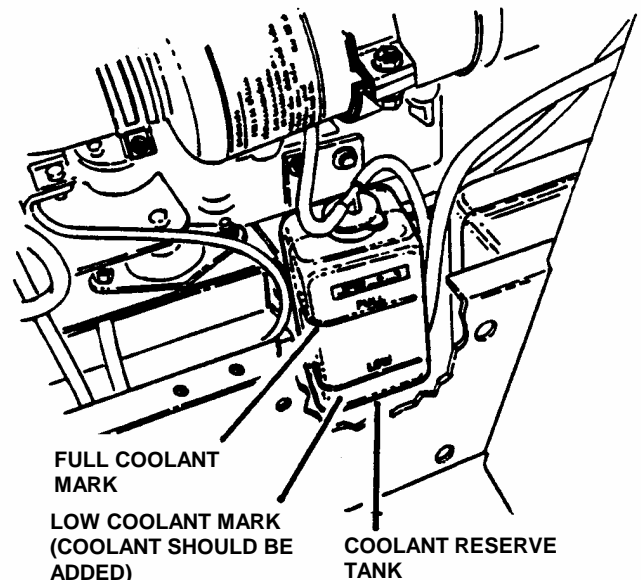

FIGURE 2.3

- 2.1.8. (Diesel Engine Models Only) Move fuel cock to the "ON" position. See Figure 3.8.

**IMPORTANT:** This machine is equipped with a WARNING beeper. The beeper will sound when engine oil pressure is low or engine temperature is high. If this beeper sounds, stop operation immediately. Do not resume operation until the cause has been determined and proper action taken. Beeper function can be verified (with engine stopped) by turning key to "RUN" position.

## Section 2 - OPERATING INSTRUCTIONS

**IMPORTANT:** This Out Front Z-Rider is equipped with hydrostatic drive. The forward and rearward movement of the machine is controlled by a joystick lever. Joystick operations should be performed only from the operator's position in the seat. A small movement of the joystick can cause the machine to move instantly. Move joystick very carefully and slowly.

**ROLL RELEASE:** To roll the machine without the engine running, pressure within the hydraulic pumps must be released. There is one lever on the upper right side of each pump that is used to release the pressure. Rotate lever counter clockwise and secure in that position. See Figure 2.4.

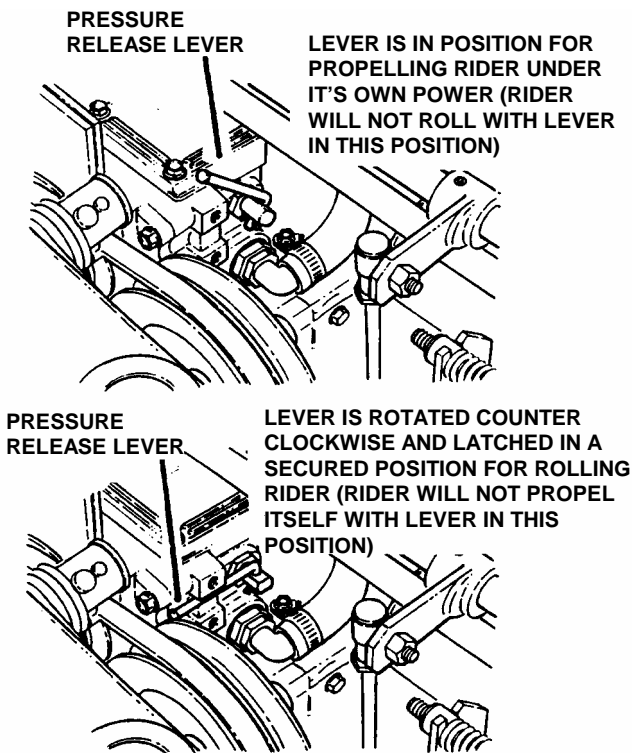

FIGURE 2.4

### 2.2 STARTING & STOPPING - ENGINE, BLADES & PARKING BRAKE

This machine is equipped with dual hydrostatic wheel drive transmissions. Each transmission is controlled by a single motion control lever or joystick. This single control lever (joystick) controls the direction of motion, Forward and Reverse, and the speed of motion. Move the joystick forward to propel the machine forward. Move the control rearward to propel the machine in reverse. The speed of motion is continuously variable from neutral (zero) to maximum.

Moving the joystick farther from the neutral position will cause the speed of motion to increase. To turn, move the joystick towards the side you want to turn to.

**DO NOT** make sudden changes in speed or direction. Always slow machine motion before turning. To stop the motion of the machine bring the joystick back to the neutral position. Engage parking brake.

#### 2.2.1. STARTING ENGINE

When the ignition key is turned to "START", the engine will not turn over unless the parking brake is engaged and the blade switch is in the "OFF" position!

Be seated on the Out Front Z-Rider before attempting to start the engine with the key switch.

1. Complete pre-start checklist.
2. Sit in operator's seat.
3. Push blade switch in to "OFF", blades disengaged position and engage parking brake. See Figure 2.2.

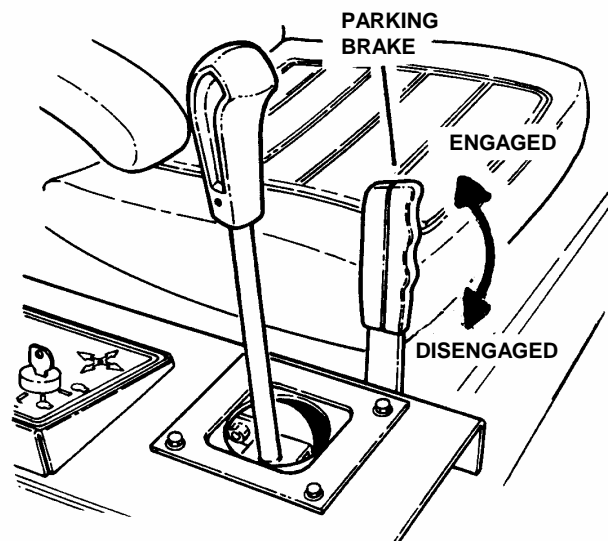

FIGURE 2.5

4. Move engine speed control to a medium speed position. See Figure 2.6.

**5. IMPORTANT: (Gasoline Engine Only).** Move engine choke control to the choke position to start a cold engine. After starting choke control must be moved to "OFF" no choke position.

# Section 2 - OPERATING INSTRUCTIONS

## 2.2.1. STARTING ENGINE (Continued from previous page)

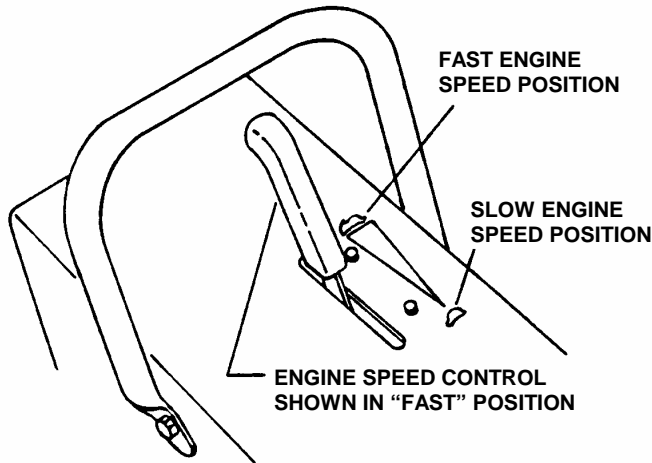

FIGURE 2.6

**6. IMPORTANT: (Diesel Engine Only)** Use the Glow Plug only if engine is cold or outside temperature is cold. Rotate key counter clockwise to the preheat position (GL letter designation on switch) to allow the glow lamp to heat up. Hold key in the Glow Plug position for a maximum of 5 seconds See Figure 2.7.

7. Rotate key clockwise to the start position until engine starts. See Figure 2.7.

**NOTE:** If after 5 seconds of cranking the engine does not start, release the key and attempt starting again after waiting for approximately 20 seconds.

### DIESEL ENGINE SWITCH POSITION

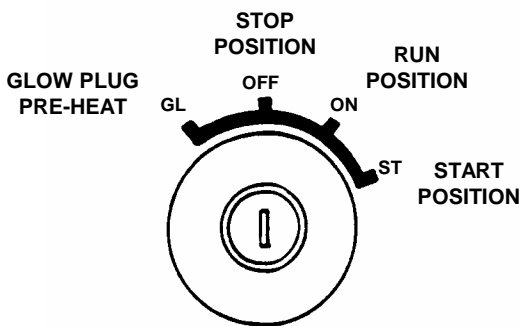

### GAS ENGINE SWITCH POSITION

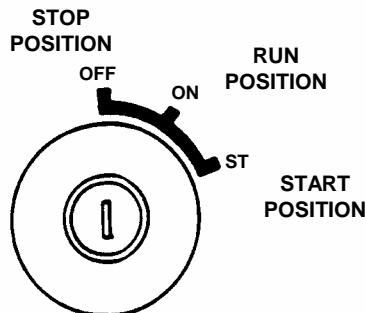

FIGURE 2.7

8. After engine starts, allow a brief warm-up until engine runs smooth.

## 2.2 STOPPING - ENGINE

### 2.2.1. ENGINE

1. Stop engine by turning key to the "OFF" position. Move engine speed control to turtle "SLOW" position and key to "STOP" position. See Figure 2.7.

**WARNING**

**DO NOT** leave machine with engine running. **STOP** blades. **STOP** engine. Set brake. Remove key.

### 2.2.2. STARTING MOWER BLADES

1. With engine running, move engine speed control to the Rabbit or "fast" position.
2. Pull the blade switch out into the "ON" position to engage the mower blades.
3. Release the parking brake.
4. Move joystick carefully in the desired direction to propel the machine. A small movement of the joystick can cause the machine to move instantly. Move joystick carefully and slowly.

**WARNING**

**DO NOT** operate blades in reverse. **STOP BLADES.** **LOOK** and **SEE** behind and down for children, pets and hazards before and while backing.

### 2.2.3. STOPPING MOWER BLADES

1. Push the blade switch in to "OFF" position to disengage or stop the mower blades. See Figure 2.2.

**WARNING**

Once blades are disengaged, they should come to a complete stop in 7 seconds. If the blades continue to rotate after 7 seconds, the electric clutch should be checked. Replacement of electric clutch may be necessary. Return the machine to an authorized Snapper dealer for replacement. **DO NOT CONTINUE** to operate mower if blades fail to stop in 7 seconds.

## Section 2 - OPERATING INSTRUCTIONS

### 2.2.4. PARKING BRAKE

1. Engage parking brake by pulling the parking brake lever back to the "ON" position. See Figure 2.8.
2. Release parking brake by moving brake lever down to the "OFF" position. See Figure 2.9.

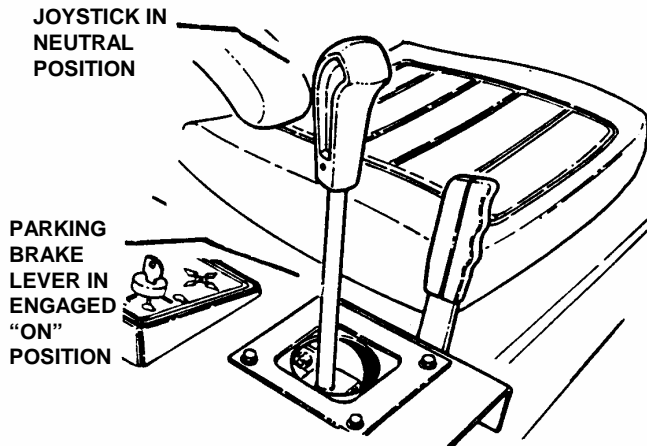

FIGURE 2.8

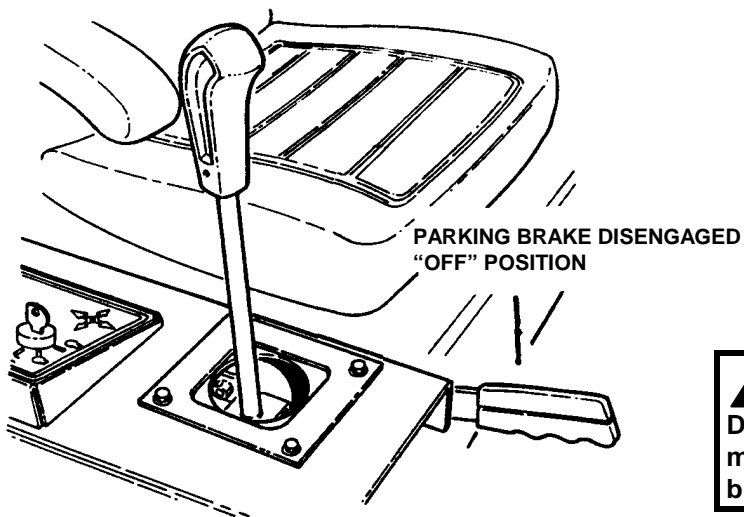

FIGURE 2.9

### 2.2.5. CUTTING HEIGHT ADJUSTMENT

1. Adjust cutting height as desired to any position, using deck lift switch. When in desired height of cut, release switch. See Figure 2.10. Observe the height of cut decal located on the upper right top side of the deck to place deck at the correct height of cut. See Figure 2.10. **NOTE:** The engine does not have to be running to adjust cutting height, but key switch must be in the "ON" position.

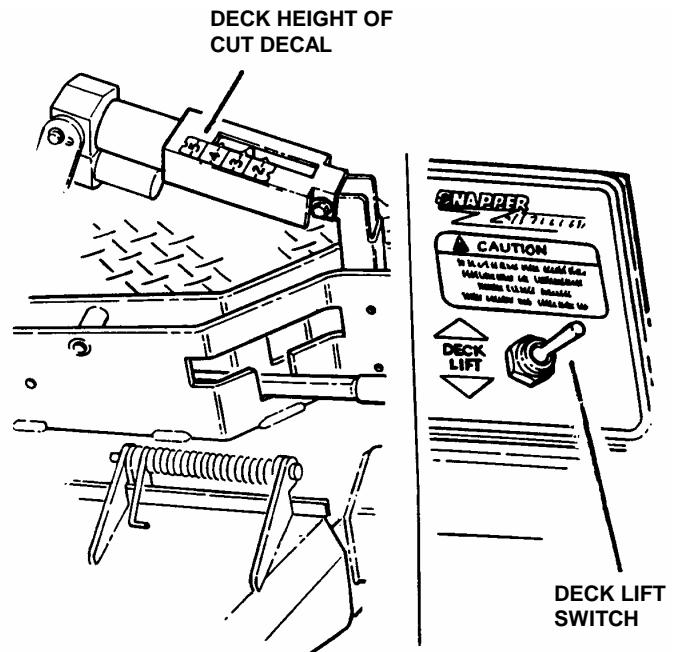

FIGURE 2.10

**WARNING**

DO NOT park the machine on slopes. DO NOT leave machine with engine running. Stop engine. Stop blades. Set brake. Remove key.

## Section 2 - OPERATING INSTRUCTIONS

### 2.3. OPERATION – MOTION CONTROL

#### 2.3.1. DRIVING MACHINE

**IMPORTANT:** The joystick lever has to be manually moved to propel machine. Always return the joystick with hand assistance to the neutral position to stop machine. Release the joystick and it will gradually return toward the neutral position. When the parking brake is engaged, it will lock joystick lever in the neutral position. The engine will only crank or start if parking brake lever is engaged and the blade switch is in the “OFF” position.

1. With engine running, adjust engine speed control to Rabbit or “Fast” position.
2. Release parking brake.
3. Move joystick lever carefully and slowly into desired speed position. A small movement of the joystick can cause the power unit to move instantly. Move joystick carefully and slowly.

**FORWARD** – Move control forward.

**REVERSE** – Move control to the rear.

**LEFT TURN** - Move control towards left.

**RIGHT TURN** - Move control towards right.

**ZERO RADIUS TURN** – Move control diagonally from neutral in desired direction. See Figure 2.11.

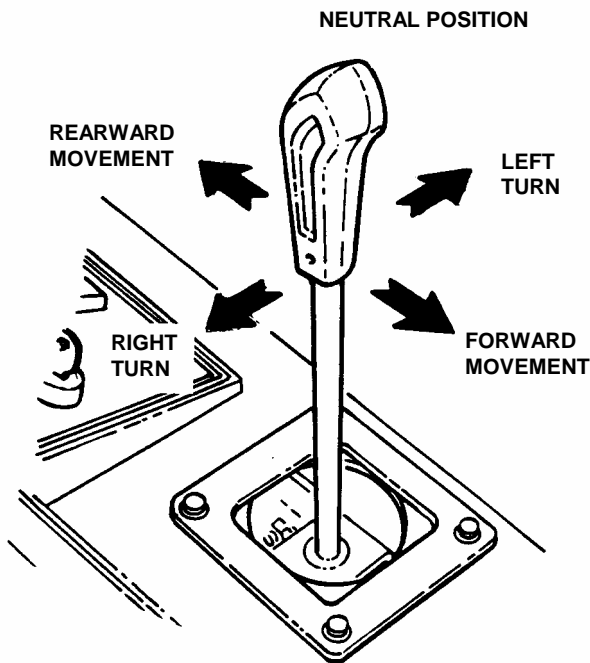
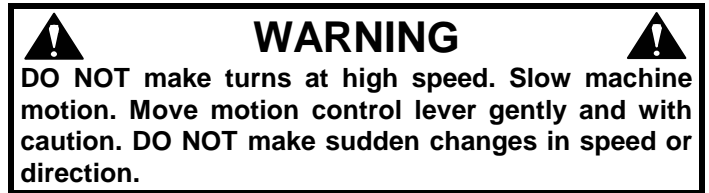

FIGURE 2.11

# Section 3 - MAINTENANCE

## 3.1 INTRODUCTION

To retain the quality of the SNAPPER Out Front Z-Rider, use genuine SNAPPER replacement parts only. Contact a local SNAPPER dealer for parts and service assistance. For the correct part or information for a particular SNAPPER Out Front Z-Rider, always mention the model and serial number. SNAPPER recommends returning the Out Front Z-Rider to an authorized SNAPPER dealer annually for inspection and addition of any new devices which might upgrade the safety of the Out Front Z-Rider. For the nearest SNAPPER dealer in your area, check the yellow pages under the heading LAWN MOWERS. For engine parts and service, look for the engine manufacturer's dealers under the heading, ENGINES - gasoline.

## 3.2 SERVICE - AFTER FIRST 5 HOURS

5. Change oil filter at every oil change. Refer to your engine owner's manual for service instructions.

### 3.2.2. CHECK MOWER BLADE

1. Stop Engine.
2. Engage parking brake.
3. Turn key to "ON" position but DO NOT start engine. Raise mower deck off the ground using deck lift switch located to the right of operator as viewed from the operator's position. Turn key to "OFF" position. Remove key.
4. Use a hydraulic floor jack or hoist to raise deck high enough to gain access to the underside of deck. Secure deck with safety blocks.

**WARNING**

DO NOT attempt any adjustments, maintenance or service with the engine or blades running. Stop blades. Stop engine. Set brake. Remove key. Remove spark plug wires from spark plugs and (gas only) secure wires away from spark plugs. Engine and components are HOT. Avoid serious burns by allowing all parts sufficient time to cool.

**WARNING**

Wear heavy leather gloves when handling or working around cutting blades. Blades are extremely sharp and can cause severe injury. DO NOT use a cutting blade that shows signs of excessive wear or damage. Refer to Section "MOWER BLADE REPLACEMENT" for proper blade inspection and service procedures.

### 3.2.1. CHANGE ENGINE OIL

1. Place a 4 quart minimum capacity container under the bottom of engine.
2. Remove the oil drain plug. See Figure 3.1.

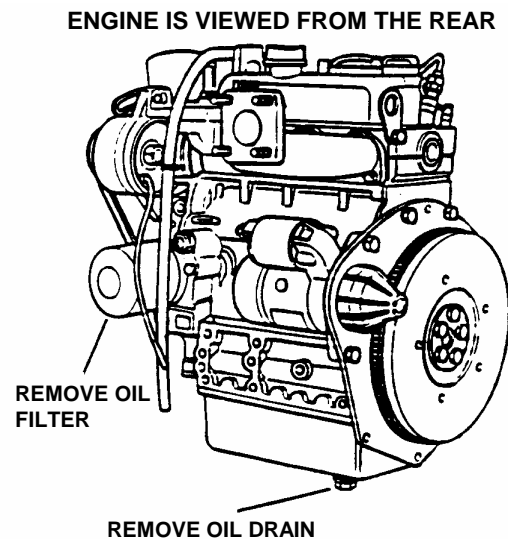

FIGURE 3.1

3. After all the oil has drained, reinstall oil drain plug and tighten securely. See Figure 3.1. Wipe up any oil that may have spilled. Dispose of drained oil properly.
4. Fill engine crankcase with new oil. Refer to your engine owner's manual for oil specifications.

5. Check torque of blade mounting bolts. Torque to 70 to 80 ft. lbs. See Figure 3.2.

6. Check blade for sharpness, wear, straightness and damage. Refer to Section "BLADE WEAR LIMITS".

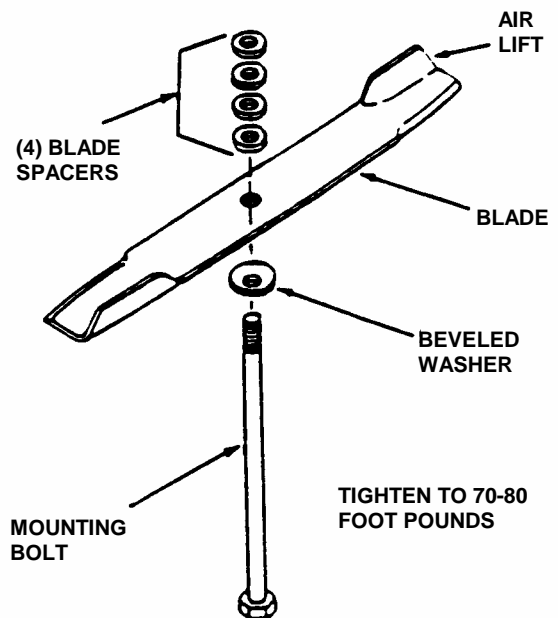

FIGURE 3.2

## Section 3 - MAINTENANCE

### 3.2.3. CHECK MOWER DRIVE BELT

#### 1. Drive Belt Cover Removal

- Lower deck to lowest setting.
- Remove knobs that secure the deck cover. See Figure 3.3.
- Remove cover to gain access to deck belt.

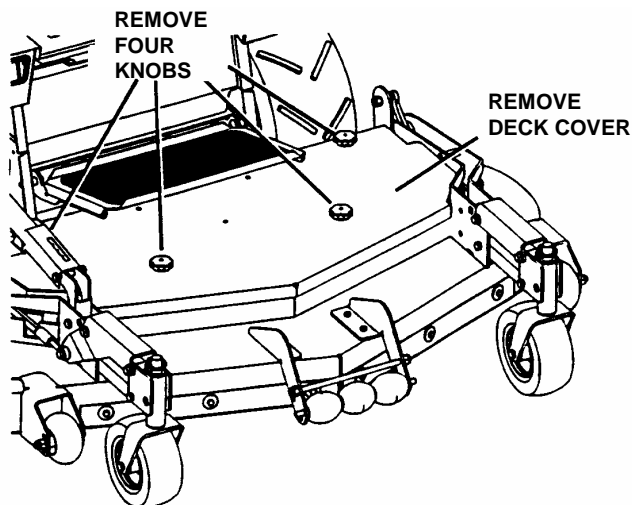

FIGURE 3.3

#### 2. Checking Belt Tension

The idler and spring provide proper belt tension and require no adjustment. If belt is frayed, slit, severed or belt strands exposed, replace belt before operating mower.

### 3.3 AFTER EVERY 25 OPERATING HOURS

#### 3.3.1. ENGINE

##### 1. Engine Oil

Change engine oil. Refer to Section "CHANGE ENGINE OIL". Refer to engine owner's manual for oil specifications.

##### 2. Air Filter

Refer to engine owner's manual for service instructions.

##### 3. Radiator - SEE WARNING

- Clean radiator debris screen and cooling fins thoroughly. Refer to engine owner's manual for service instructions.
- Check coolant level in reserve tank.

#### 3.3.2. MOWER COMPONENTS

##### 1. Mower Drive Belt

No adjustment required. Replace belt as needed.

##### 2. Mower Blade

Check blade for sharpness, wear, damage, and torque. Refer to Section "MOWER BLADE REPLACEMENT".

#### 3. Mower Deck Levelness

Check mower deck for proper levelness. Adjust as required. Refer to Section "MOWER DECK ADJUSTMENT - LEVELNESS".

#### 4. Cleaning Mower Deck

- Remove key from ignition switch.
- Remove spark plug wire(s) and secure away from spark plug(s). GAS ENGINE ONLY.
- Raise mower deck to its highest setting. It may be necessary to raise mower deck higher using a hydraulic floor jack. Secure deck with safety blocks.
- Clean underside of mower deck, removing all accumulation of grass clippings and debris.
- Clean top of deck, removing all grass clippings and debris.

#### 5. Mower Blade Spindle - Lubrication

- Remove four knobs that secure the deck cover.
- Remove cover to gain access to lubrication fitting located on the top of deck below deck pulleys. Lubricate with Kendall NLGI No. 2 lithium grease or equivalent, from a grease gun until grease purges from vent located on spindle housing underneath deck. See Figure 3.4.

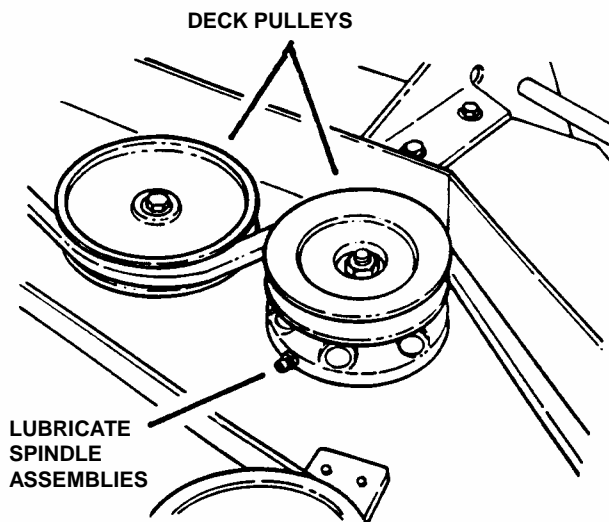

FIGURE 3.4

#### 6. Mower Deck Linkage - Lubrication

Lubricate all mower deck linkage pivot points with a light coat of motor oil.

**WARNING**

DO NOT remove cap from radiator when engine and coolant are hot. Coolant is pressurized. Severe burns could result.

# Section 3 - MAINTENANCE

## 3.3.3. RIDING MOWER - LUBRICATION

### 1. Front & Rear Wheel Bearings

Lubricate with Kendall NLGI No. 2 lithium grease or equivalent, from a grease gun. See Figure 3.5.

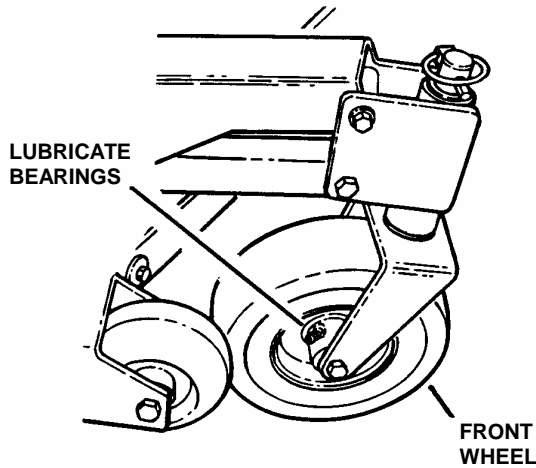
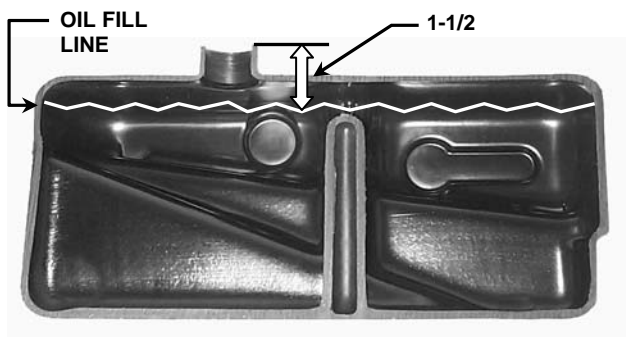

FIGURE 3.5

### 2. Transaxle

Check the level of fluid in both of the fluid reservoirs. Wipe away all dirt and debris from around reservoir cap before removing. Oil must remain absolutely clean! Check with mower on a level surface with engine "OFF". Fill reservoir as needed to bring level up to 1-1/2 inches below the top of the filler neck. Use clean, fresh premium hydraulic oil having a viscosity equivalent to SAE 20W-20, SAE 30 or SAE 40. The fluid should be chemically stable, incorporating rust and oxidation inhibitors. Make sure funnels, pouring spouts and oil can are completely clean. Reinstall reservoir cap. See Figure 3.6. **IMPORTANT:** DO NOT remove or service the transaxle fluid filters. This service should be made periodically by an authorized SNAPPER dealer. See the service schedule to determine the recommended change interval.



HYDRAULIC OIL RESERVOIR

**IMPORTANT: FLUID LEVEL MUST BE ABOVE TOP OF BAFFLE. RESERVOIR CAPACITY IS ONE (1) GALLON. DO NOT OVERFILL.**

FIGURE 3.6

### 3. Power Transfer Shaft

Lubricate power transfer shaft with Kendall NLGI No. 2 lithium grease or equivalent, from a grease gun. See Figure 3.7.

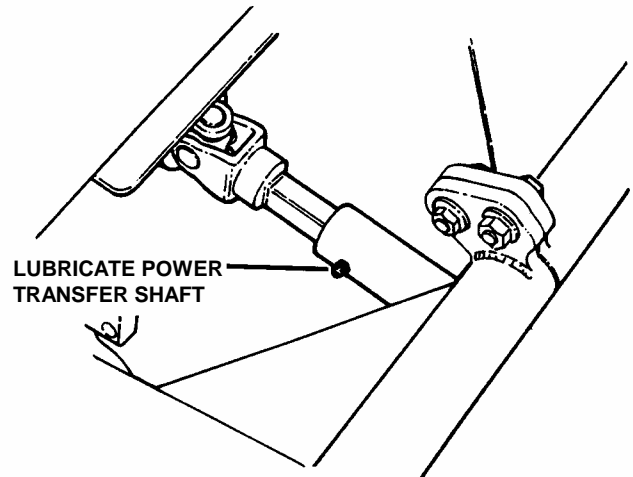

FIGURE 3.7

### 4. OTHER LUBRICATION POINTS

Lubricate traction drive idlers, P.T.O. idlers, deck caster wheel shafts, rear caster wheel shaft, traction drive shaft bearings and mower deck idler arm with Kendall NLGI No. 2 lithium grease or equivalent, from a grease gun.

### 3.4 BEFORE OPERATING MOWER

1. Clean all dirt and debris from around the two hydraulic fluid reservoirs. Especially around the top and cap area.
2. Clean all dirt and debris from the radiator debris screen and cooling fins.
3. Clean all dirt and debris from the cooling fins on the engine and from both hydraulic pumps.

### 3.5 ANNUALLY (END OF EACH SEASON)

Perform all maintenance as required in SERVICE SCHEDULE section of this manual.

#### 3.5.1. ENGINE

Service engine according to engine owner's manual.

(Continued on next Page)



## Section 3 - MAINTENANCE

### 3.5 ANNUALLY (END OF EACH SEASON) (Continued from previous Page)

#### 3.5.2. FUEL FILTER (DIESEL ENGINE ONLY)

Service fuel filter as instructed in engine owner's manual. Turn key to "OFF" position. Engine MUST be stopped and MUST be cold before removing filter.

1. Move the fuel filter cock handle to the closed position.
2. Remove the fuel filter bowl retaining ring. Fuel filter bowl, two "O" Rings, spring and filter can be removed. See Figure 3.8.
3. Replace filter element. Clean filter bowl with fresh diesel fuel. Reassemble the fuel filter bowl assembly. Tighten retaining ring securely. Check for leakage. Air bleed the fuel system.
4. Fill the fuel tank to the fullest extent. Open the fuel filter cock.
5. Loosen air vent plug a few turns at the top of fuel filter/fuel cock assembly. Allow air bubbles to be released. Close air vent plug when a steady flow of fuel is observed.

NOTE: After replacing fuel filter, engine may have to be cranked briefly with air vent plug loosened to purge all air from system.

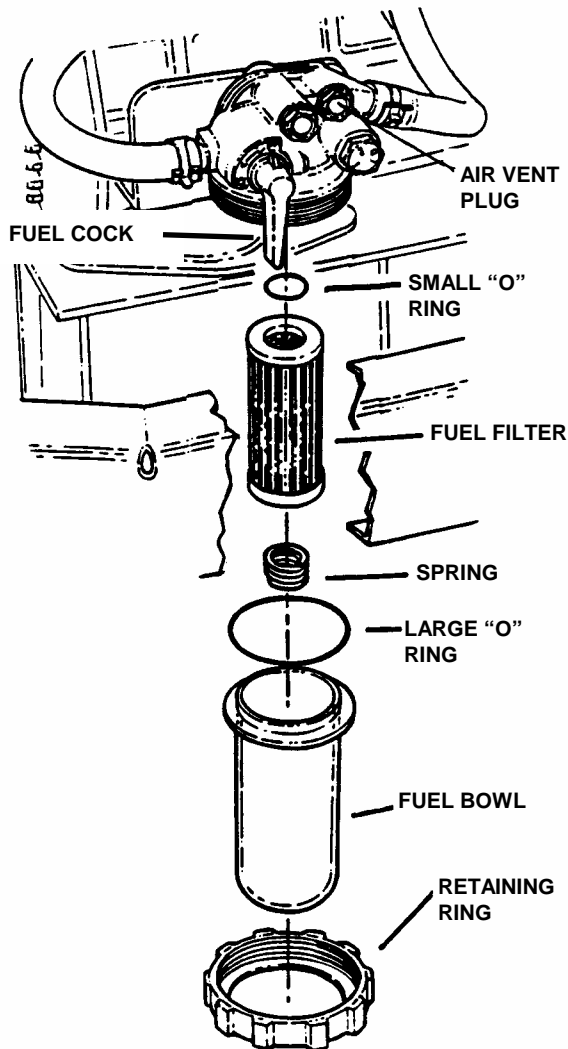

FIGURE 3.8

### 3.6 DECK REMOVAL

Move machine to an area where the mower deck is to be disconnected. Turn engine "OFF" but leave key switch in the "ON" position. Engage parking brake.

1. The rear of deck must be raised up and both jack stands moved down to the lowest position and both locking pins inserted. NOTE: Jack stands are stored on the left and right rear sides of the mower.
2. Using deck lift switch, lower deck down to rest on jack stands.
3. The hitch latch pins are shown in the latched position. The latched position locks the deck lift arm into position. See Figure 3.9.

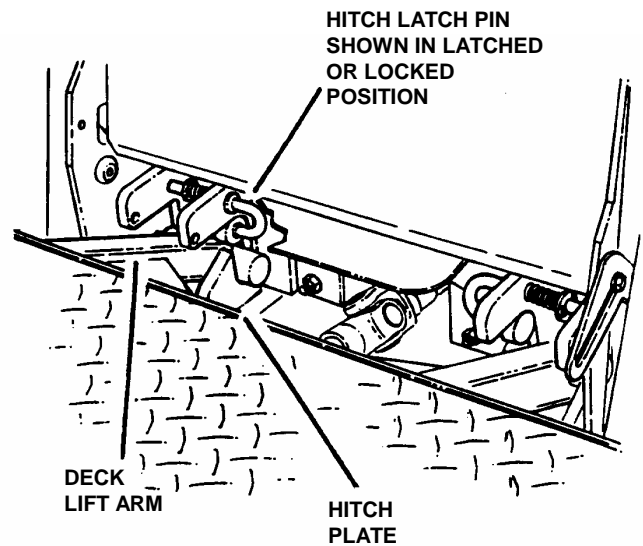

FIGURE 3.9

(Continued on Next Page)

	<b>WARNING</b>	
<p>Allow engine to cool for at least ten minutes before performing service or maintenance. DO NOT smoke near fuel components when performing service or maintenance. DO NOT perform service and maintenance near an open flame. Wipe off any spilled fuel before starting engine. DO NOT run engine indoors.</p>		

## Section 3 - MAINTENANCE

### 3.6 DECK REMOVAL

(Continued From Previous Page)

4. Rotate spring loaded hitch latch pins (Located on both hitch plates) to the unlatched position. See Figure 3.10.

5. Move deck lift switch as if to lower deck and the lift arm will move up in the hitch plates. The lift arm needs to be high enough to clear the hitch plates when power unit is driven backward away from mower deck. See Figure 3.9.

6. Pull lock collar back and slide power transfer shaft away from power take off (PTO) shaft. See Figure 3.11.

7. Disconnect wiring harness from mower deck.

8. Start power unit. Disengage parking brake. Carefully move power unit backward away from mower deck.

**NOTE: DECK LIFT ARM SHOWN REMOVED FOR CLARITY. DECK WOULD NOT BE REMOVED AT THIS TIME IN DECK REMOVAL PROCEDURE.**

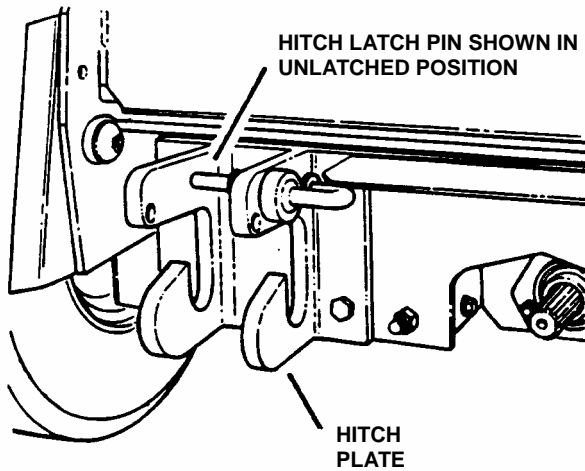

FIGURE 3.10

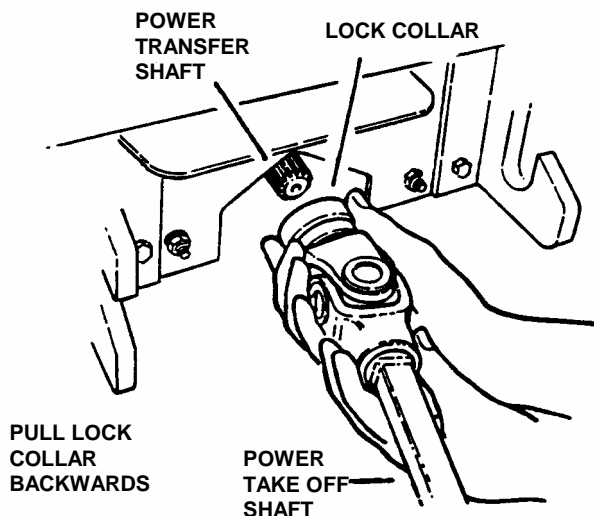

FIGURE 3.11

### 3.7 POWER TRANSFER SHAFT REMOVAL

Engage parking brake. Turn engine "OFF" and remove key. The power transfer shaft connects the power unit to the mower deck. The shaft is telescoping for easy removal. Slide locking collar back toward mower deck and shaft will slide off. See Figure 3.11.

	<b>WARNING</b>	
<p><b>DO NOT attempt any maintenance, adjustments or service with engine running. STOP engine. STOP blades. Set brake. Remove key. Remove spark plug wires and secure away from spark plugs. Engine and components are HOT. Avoid serious burns, allow sufficient time for all parts to cool.</b></p>		

# Section 4 - ADJUSTMENTS & REPAIR

**⚠ DANGER ⚠**  
Exercise **EXTREME CAUTION** when making this adjustment, due to close proximity of moving parts.

## 4.1 NEUTRAL POSITION ADJUSTMENTS

The joystick controls the movement and stopping of the machine. Move the joystick to the center or neutral position to stop machine. **IMPORTANT:** Always return the joystick with hand assistance to the neutral position. If machine does not come to a complete stop or has any movement when joystick is moved to the neutral position, adjustment must be made.

1. Turn key to "OFF" position.
2. Raise both wheels off the ground. Wheels should be high enough to rotate freely. Secure with safety blocks.
3. Disconnect parking brake rod from parking brake.
4. Engage parking brake lever. NOTE: Engaging parking brake without brake rod connected will lock joystick in center or neutral position.
5. Turn key to start position and start engine.
6. Both wheels should be still, not rotating.
7. If wheel(s) are rotating, disconnect transmission control rods from cross shaft and turn adjusting bolts located on pump(s) clockwise, or counter-clockwise, until wheel(s) stop rotating. See Figure 4.1.
8. With wheels in neutral, (not rotating) stop engine and readjust the length of the control rods until they fit into the cross shaft arms and reconnect. Tighten securely.
9. Reconnect park brake rod.
10. Start engine. Release park brake. Wheels should not be rotating if adjusted properly. Repeat adjustment if necessary.

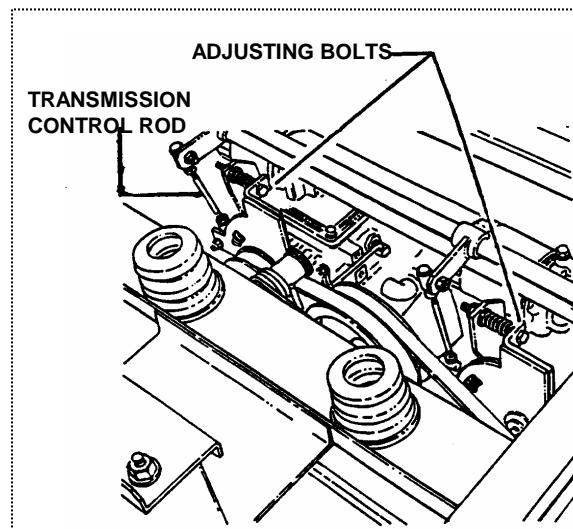

FIGURE 4.1

## 4.2 MOWER DECK & COMPONENT ADJUSTMENTS

The following mower deck and component adjustments and repairs can be made by the owner. However, if there is difficulty in making these adjustments and repairs, it is recommended that these repairs be made by an authorized SNAPPER dealer.

### 4.2.1. MOWER DECK ADJUSTMENT (LEVELNESS) SIDE to SIDE and FRONT to REAR

Before making deck leveling adjustments, check tires and add or release air as needed to bring pressure to 12 psi in drive tires (Turf Type Tires), 5 psi (All Terrain Type Tires) and 25 psi in rear caster tires. Pressure in front deck caster wheels should be 25 psi.

If tires are properly inflated and mowing is still uneven, adjust deck levelness as follows:

1. Place mower on a smooth level surface.
2. Raise deck to highest cutting position.
3. Place 2x4 blocks under front edge of deck beside caster wheels. Blocks should be on both sides of deck. Make deck relatively level by positioning blocks. Both caster wheels must be off the ground.
4. Loosen leveling bracket at center rear deck support. See Figure 4.2. This allows the lift arm to settle down into hitch brackets.

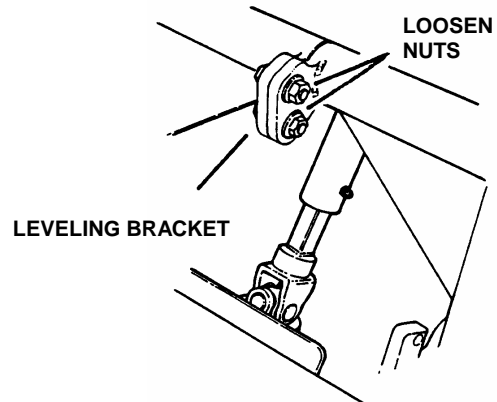

FIGURE 4.2

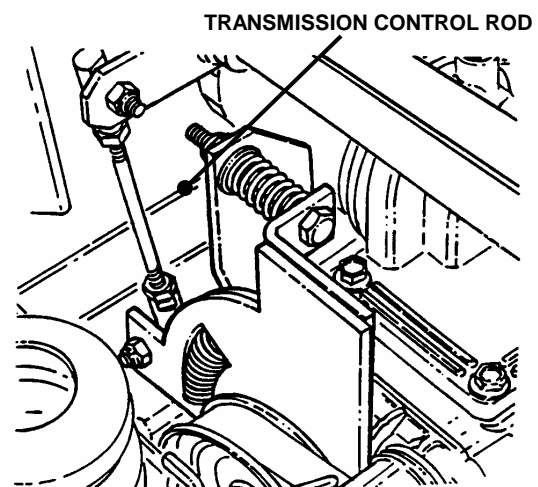

FIGURE 4.1A

## Section 4 - ADJUSTMENTS & REPAIR

### 4.2.1. MOWER DECK ADJUSTMENT (LEVELNESS)

**SIDE to SIDE and FRONT to REAR**

(Continued from previous page)

5. Retighten leveling bracket bolts.
6. Remove both bolts (one from each side) from the front portion of the link weldment. See Figure 4.3. The front caster wheel will drop to the ground.
7. Turn ball joint in or out until ball joint anchor hole aligns with mounting hole. Reinstall bolt and tighten securely. Use same procedure on other caster wheel. See Figure 4.3.
8. Reinstall bolts and tighten securely.
9. Remove blocks from under front of deck.
10. **Side to Side Level:** Check blade tips by rotating blades until tips are pointing to the side of the deck. Check the measurement of outside blade tips to the ground on both blades. The measurement of each outside blade tips should be within 1/8" of each other.
11. **Front to Rear Level:** Check blade tips by rotating blades until tips are pointing to the front and rear of deck. Check the blade tip measurements of each blade. Front to rear measurement should be 1/4" to 3/8" higher in the rear.

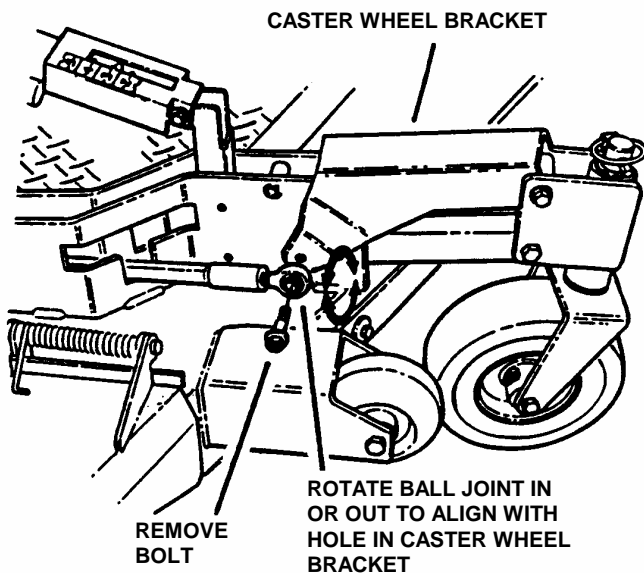

FIGURE 4.3

### 4.3 PARKING BRAKE ADJUSTMENT

- 4.3.1 The park brake can be adjusted by removing the rod from the lever and rotating clockwise to increase brake tension. When properly adjusted the park brake lever should require 18 to 22 pounds force to set the brake. If this adjustment does not result in proper brake action, contact your authorized Snapper dealer for corrective action. See Figure 4.4.

**WARNING**  
DO NOT operate machine if brakes are not functioning properly.

### 4.4 ENGINE ADJUSTMENTS & REPAIR

Refer to the engine owner's manual for engine adjustments and/or repairs.

### 4.5 MOWER BLADE REPLACEMENT

#### 4.5.1. BLADE WEAR LIMITS

1. Inspect blade frequently for signs of excessive wear or damage. See Figure 4.5.

**WARNING**  
Wear heavy leather gloves when handling or working around cutting blades. Blades are extremely sharp and can cause severe injury. DO NOT use a cutting blade that shows signs of excessive wear or damage.

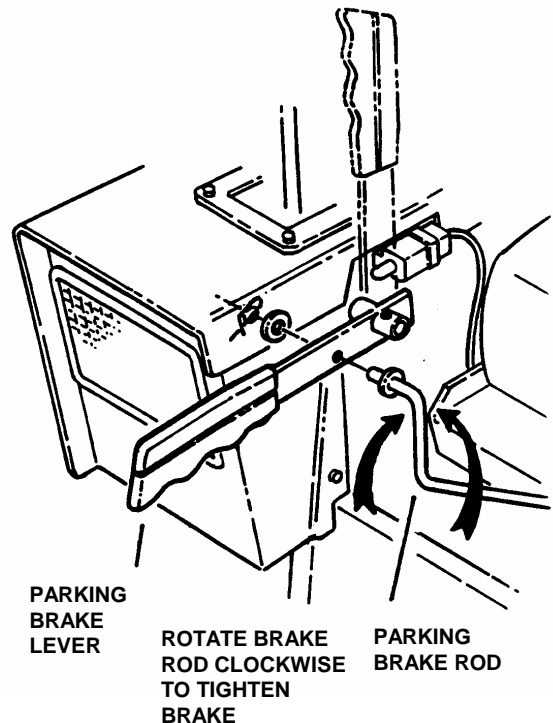

FIGURE 4.4

**WARNING**  
DO NOT attempt any adjustments, maintenance or service with the engine or blades running. Stop blades. Stop engine. Set brake. Remove key. Remove spark plug wires from spark plugs and (gas only) secure wires away from spark plugs. Engine and components are HOT. Avoid serious burns by allowing all parts sufficient time to cool.

# Section 4 - ADJUSTMENTS & REPAIR

## 4.5 MOWER BLADE REPLACEMENT

### 4.5.1. BLADE WEAR LIMITS

(Continued from previous page)

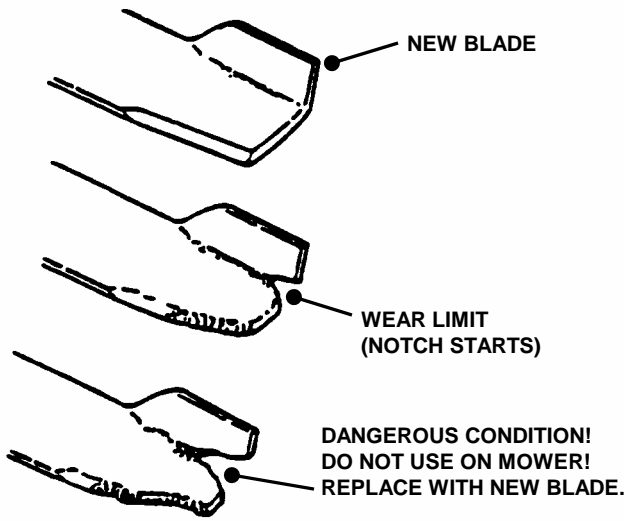

FIGURE 4.5

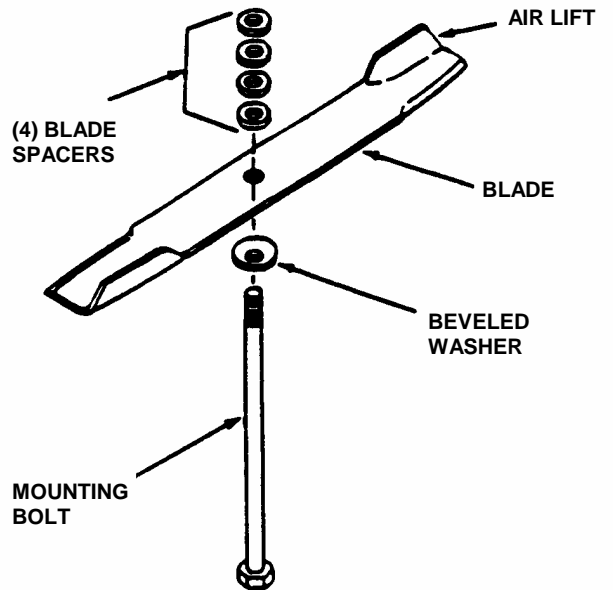

FIGURE 4.6

	<b>WARNING</b>	
<p>DO NOT use a cutting blade that shows signs of excessive wear or damage. Refer to Figure 4.5. Wear heavy leather gloves when handling or working around cutting blades. Blades are extremely sharp and can cause severe injury.</p>		

### 4.5.2. BLADE SHARPENING

1. Remove blade. See Figure 4.6.
2. Inspect condition of blade. See Figure 4.5.
3. If blade is in good condition, sharpen at 22 to 28 degrees. DO NOT sharpen beyond existing cutting edge. See Figure 4.7.
4. Check blade balance after sharpening. If necessary, correct blade balance by grinding the heavy end of blade. **IMPORTANT:** Blade balancing should be performed by a qualified dealer.
5. Reinstall blade. See Figure 4.5. Torque blade mounting bolts to recommended range of 70 to 80 ft. lbs.

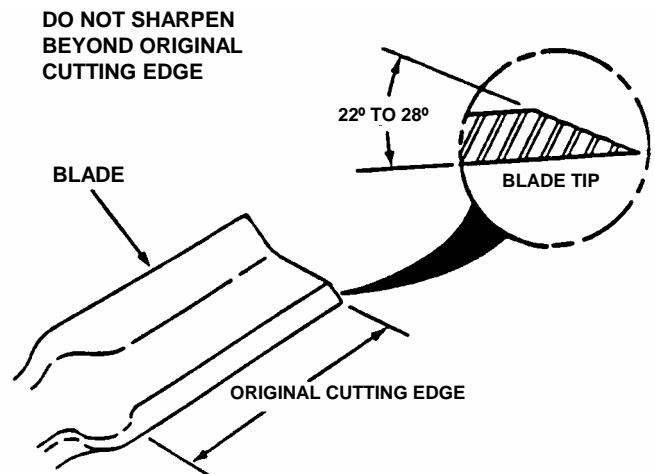

FIGURE 4.7

## Section 4 - ADJUSTMENTS & REPAIR

### 4.6 MOWER DRIVE BELT, ENGINE BELT & HYDRO PUMP BELT REPLACEMENT

Inspect all belts. Replace belt if it shows signs of excessive wear, damage and/or is broken.

**WARNING**

**DO NOT** attempt any adjustments, maintenance or service with the engine or blades running. Stop blades. Stop engine. Set brake. Remove key. Remove spark plug wires from spark plugs and (gas only) secure wires away from spark plugs. Engine and components are **HOT**. Avoid serious burns by allowing all parts sufficient time to cool.

#### 4.6.1. MOWER DRIVE BELT REMOVAL

1. Remove mower drive belt cover.
2. Remove old belt.

#### 4.6.2. MOWER DRIVE BELT REPLACEMENT

1. Route belt around blade pulleys and idler pulley as shown. It may be necessary to use a pry bar to pull idler pulley back to install belt. See Figure 4.8.
2. Reinstall belt cover.

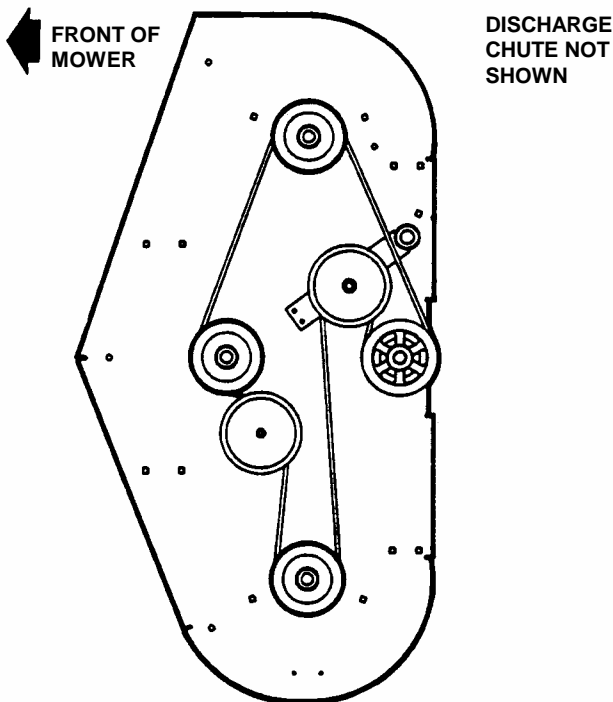

FIGURE 4.8

#### 4.6.3. ENGINE BELT REMOVAL

1. Remove radiator screen.
2. Remove nut and bolt that secure the top portion of alternator cover. Rotate cover to the side. See Figure 4.9.

3. Remove the nuts and bolts that secure the metal couplings to the rubber flex coupling. Remove rubber flex coupling to allow space to remove and install belt.

4. Remove belt from around pulleys and fan. Pull belt through where rubber flex coupling was located.

5. Install new belt in reverse order.

6. Reinstall rubber flex coupling. Reinstall alternator cover and radiator screen. Reinstall all nuts and bolts. Tighten all nuts and bolts securely.

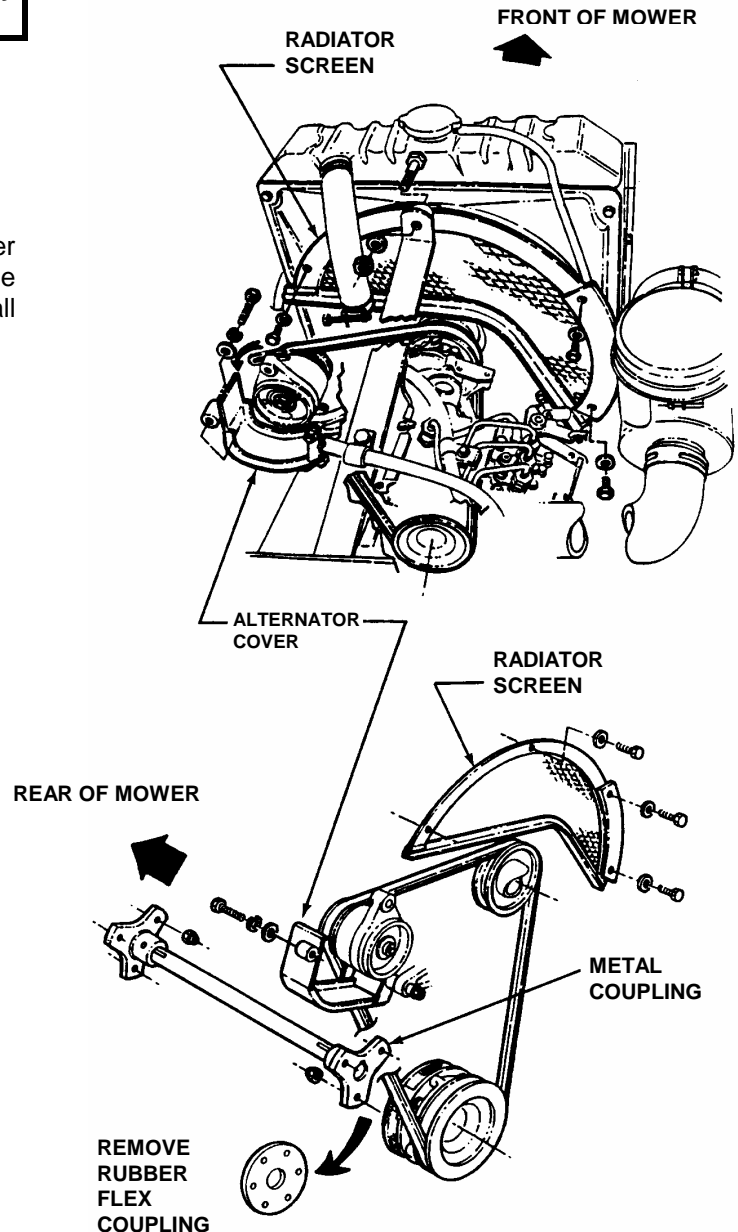

FIGURE 4.9

## Section 4 - ADJUSTMENTS & REPAIR

### 4.7 BATTERY

#### 4.7.1. BATTERY REMOVAL

1. Remove battery retainer.
2. Slide battery from battery box to gain access to terminal cables.
3. Observe and note cable positions on battery. See Figure 4.10.
4. Disconnect cables from battery terminals, disconnecting BLACK (Negative) cable first, then disconnect RED (Positive) last. Retain mounting bolts and nuts.

**WARNING**  
Cables must be connected to battery terminals in the proper position. RED (Positive) cable must go to the (+) terminal. BLACK (Negative) cable must go to the (-) terminal.

#### 4.7.2. BATTERY INSTALLATION

1. Slide battery partially into battery compartment.
2. Connect cables to battery terminals. Connect RED (Positive) cable first. Connect BLACK (Negative) cable last.
3. Reinstall battery retainer and positive terminal cover.

**BATTERY REMOVAL:**  
DISCONNECT BLACK CABLE (NEGATIVE) FIRST,  
DISCONNECT RED CABLE (POSITIVE) LAST.

**BATTERY INSTALLATION:**  
CONNECT RED CABLE (POSITIVE) FIRST,  
CONNECT BLACK CABLE (NEGATIVE) LAST.

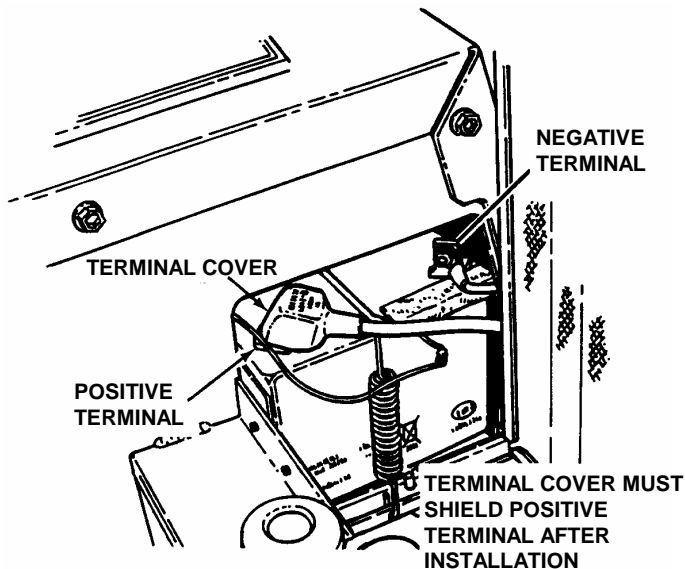

FIGURE 4.10

**WARNING**  
The electrolyte (acid) produces a highly explosive gas. Keep all sparks, flame and fire away from area when charging battery or when handling electrolyte or battery. Electrolyte (acid) is a highly corrosive liquid. Wear eye protection. Wash affected areas immediately after having eye or skin contact with electrolyte (acid). Battery acid is corrosive. Rinse empty acid containers with water and mutilate before discarding. If acid is spilled on battery, bench, or clothing, etc., Flush with clear water and neutralize with baking soda.

#### 4.7.3. BATTERY SERVICE



1. Remove battery.
2. Place battery in a well ventilated area on a level surface.
3. Using distilled water, refill cells as required to cover cell plates.
4. With cell caps removed, connect battery charger to battery terminals. RED to positive (+) terminal and BLACK to negative (-) terminal.
5. Slow charge battery at 1 amp for 10 hours. An alternative fast charge should be no more than 2.5 amps for four hours.
6. If battery will not accept charge or is partially charged after 10 hours of charging at 1 amp, replace with new battery.

(Continued on Next Page)

## Section 4 - ADJUSTMENTS & REPAIR

### 4.7 BATTERY

Battery Condition Chart			
State of Charge	Syringe Hydrometer	Digital Voltmeter	Five Ball Hydrometer
100% Charged w/ Sulfate Stop	1.280	12.80v	Five Balls Floating
100% Charged	1.265	12.60v	Four Balls Floating
75% Charged	1.210	12.40v	Three Balls Floating
50% Charged	1.160	12.10v	Two Balls Floating
25% Charged	1.120	11.90v	One Ball Floating
0% Charged	Less than 1.100	Less than 11.80v	Zero Balls Floating

 **WARNING** 

Shield the positive terminal with terminal cover located on battery harness. This prevents metal from touching the positive terminal, which could over heat battery and/or battery cable and cause sparks. **DO NOT** attempt to charge battery while installed on the Zero Turning Radius Mower. **DO NOT** use “BOOST” chargers on the battery.

#### 4.7.4. BATTERY TESTING

There are two types of battery tests: Unloaded and Loaded. The unloaded test is the procedure that will be discussed. It's the simplest and most commonly used. An unloaded test is made on a battery without discharging current. To perform unloaded testing, check charge condition using either a hydrometer or voltmeter.

1. Using a voltmeter, voltage readings appear instantly to show the state of charge. Remember to hook the positive lead to the battery's positive terminal, and the negative lead to the negative terminal.

2. A hydrometer measures the specific gravity of each cell. The specific gravity tells the degree of charge; generally, a specific gravity of about 1.265 to 1.280 indicates full charge. A reading of 1.230 to 1.260 indicates the battery should be charged before testing. The chart on the next page shows the charge level as measured by syringe float hydrometer, digital voltmeter and five ball hydrometer.

#### 4.7.5. NEW BATTERY PREPARATION

1. Remove battery from carton.
2. Place battery in a well ventilated area on a level non-concrete surface.

 **WARNING**   
**DO NOT OVERFILL!**

3. Remove battery cell caps. Fill cells as required with electrolyte (purchased separately) to proper level. Fill to 3/16" above cell plates. Filling battery with electrolyte will bring the battery to 80% charged state.

4. With cell caps removed, connect battery charger to battery terminals; RED to positive (+) and BLACK to negative (-) terminal.

**IMPORTANT:** 3/16" above cell plates is the recommended level. **DO NOT** place anything in battery other than specified electrolyte.

5. Slow charge the battery at 1 amp for 2 hours to bring the battery to full charge.

6. After charging, check level of electrolyte and add as needed to bring level to 3/16" above cell plates.

7. Reinstall cell caps.

8. Install battery into power unit.

9. Connect positive (+) cable (red) first, from wiring harness to the positive terminal (+) on battery using bolt and nut provided in hardware bag. Connect negative (-) cable (black) last, to negative terminal (-) on battery using bolt and nut. Apply a small amount of grease over terminals to prevent corrosion.



## Section 4 - ADJUSTMENTS & REPAIR

### 4.8 MOWER SPINDLES (Field Serviceable Spindles) BEARING REPLACEMENT

In the event that a spindle bearing requires replacement, the SNAPPER Field Serviceable Spindles have been designed so that no special tools or presses are required.

1. Remove belt. Loosen blade nut and remove. Allow blade bolt, washer, blade and four spacers to drop down out of the spindle housing. See Figure 4.11.

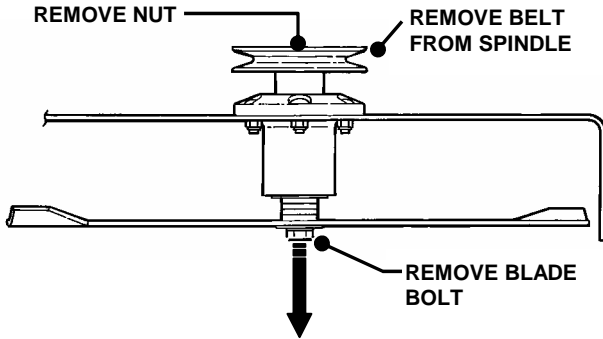

FIGURE 4.11

2. Remove spindle pulley from spindle shaft.
3. Locate circular retaining ring on spindle shaft at top bearing. Remove retaining ring. Allow spindle shaft to drop out of housing.
4. Top and bottom bearings are now removable. Pull out on inner race to slide bearing from housing. See Figure 4.12.

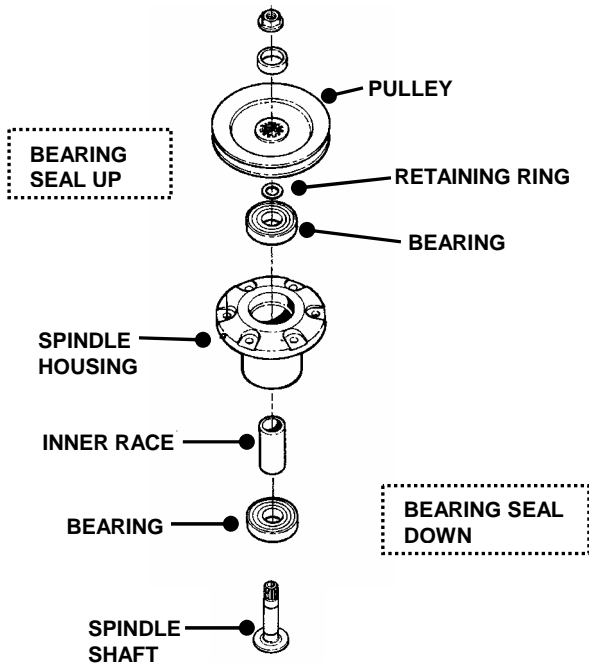

FIGURE 4.12

5. Thoroughly clean all parts removing all old contaminated grease.
6. Install new bottom bearing first.

**NOTE:** The bearing is sealed/shielded on one side only. The bottom bearing must be installed with the sealed/shielded side DOWN.

7. Insert spindle shaft up through the bottom bearing. Slide spacer down over spindle shaft.

8. Install new top bearing. Install the top bearing with the seal/shield UP.

9. Slide circular retaining ring down spindle shaft until it fully locks into groove on shaft.

10. Place spindle pulley and spacer on top of spindle shaft.

11. Reinstall blade bolt, washer, blade and four spacers.

12. Torque blade bolt and nut to 60 to 75 ft. lbs.

**IMPORTANT: Spindle housing must be filled with grease before operating mower. Failure to fill housing will cause premature bearing failure.**

13. Pump grease into spindle housing until grease purges from vent on housing.

14. After the first 5 hours of operation, grease spindle housing to insure it is full, then every 25 hours.

# TROUBLESHOOTING

PROBLEM	PROBABLE CAUSE	CORRECTIVE ACTION
<b>Starter Will Not Crank Engine</b>	1. Battery dead.	1. Service battery.
	2. Blown fuse.	2. Replace fuse.
	3. Electrical connections loose or corroded.	3. Clean and check connections for good contact.
	4. Defective ignition switch.	4. Contact authorized <b>SNAPPER</b> dealer.
<b>Engine Will Not Start</b>	1. Blade engagement switch in the "ON" position.	1. Move blade engagement switch to "OFF".
	2. Park brake not set.	2. Set park brake.
	3. Fuel tank empty.	3. Fill fuel tank with fresh diesel fuel.
	4. Fuel filter clogged.	4. Remove and clean fuel filter of all debris.
	5. Fuel cock in the "OFF" position.	5. Move fuel cock lever to the "ON" position.
	6. Battery weak or dead.	6. Service battery.
	7. Faulty parking brake, blade or ignition switch.	7. Contact authorized <b>SNAPPER</b> dealer.
<b>Engine Stalls After Running</b>	1. Operator not in seat.	1. Sit in operator's seat.
	2. Fuel injection nozzle clogged with carbon.	2. Clean or replace fuel injection nozzle.
	3. Fuel tank empty.	3. Fill with fuel to proper level.
	4. Engine air cleaner dirty.	4. Clean air cleaner of all debris.
	5. Insufficient lubrication.	5. Check engine oil lubricating system.
	6. Fuel filter clogged.	6. Remove and clean fuel filter of all debris.
	7. Water, debris or stale fuel in fuel system.	7. Drain and clean fuel system.
<b>Engine Loses Power</b>	1. Excessive load on engine.	1. Lessen load.
	2. Engine air pre-cleaner or air cleaner dirty.	2. Clean or replace filters.
	3. Engine oil level low.	3. Fill with engine oil to proper level.
	4. Fuel injection nozzle clogged with carbon.	4. Clean or replace fuel injection nozzle.
	5. Water, debris or stale fuel in fuel system.	5. Drain and clean fuel system.
<b>Engine Backfires When Turned To "STOP"</b>	1. Throttle control set too "FAST".	1. Set throttle control to "SLOW" and allow engine to idle. Then, turn key to "OFF".
<b>Excessive Vibration</b>	1. Damaged or bent mower blades.	1. Service mower blade(s).
	2. Loose blade components.	2. Service and tighten loose parts.
	3. Loose or missing air lift (if equipped).	3. Replace air lifts. Tighten to proper torque.
<b>Engine Over Heats</b>	1. Insufficient engine lubrication.	1. Check engine oil lubrication system.
	2. Fan belt broken or out of adjustment.	2. Replace fan belt or adjust to proper tension.
	3. Insufficient coolant level.	3. Check coolant level and replenish supply.
	4. Thermostat defective.	4. Replace thermostat of correct heat range.
	5. Radiator screen or radiator cooling fins clogged.	5. Clean all debris from radiator screen and fins.
	6. Water pump, fan & radiator cap defective.	6. Replace cooling system parts that are defective.
	7. Incorrect fuel injection timing.	7. Contact authorized <b>SNAPPER</b> dealer.
	8. Excessive concentration of antifreeze.	8. Change coolant(water/antifreeze) mixture ratio.
	9. Cooling system clogged with debris.	9. Drain and flush cooling system.

(Trouble Shooting Continued on Next Page)

# TROUBLESHOOTING

PROBLEM	PROBABLE CAUSE	CORRECTIVE ACTION
<b>Tractor Will Not Move Loss Of Traction</b>	1. Joystick in the neutral "N" position.	1. Place joystick in desired speed position.
	2. Roll release lever is in "ROLL" position.	2. Move roll release lever to the engaged position.
	3. Low transmission hydraulic oil level.	3. Bring hydraulic oil to proper level.
	4. Parking Brake engaged.	4. Move parking brake to disengaged position.
	5. Traction drive belt requires replacement.	5. Replace traction drive belt.
<b>Blade(s) Not Cutting</b>	1. Blade engagement switch in the "OFF" position.	1. Move blade switch to the "ON" position.
	2. Clutch belt slipping.	2. Replace clutch belt.
	3. Mower belt slipping.	3. Replace mower belt.
	4. Electric clutch not functioning.	4. Contact authorized <b>SNAPPER</b> dealer.
	5. Check gearbox for damage.	5. Contact authorized <b>SNAPPER</b> dealer.
	6. Power transfer shaft disconnected or damaged.	6. Connect power transfer shaft or repair damage.
<b>Cutting Grass Improperly</b>	1. Uneven tire pressure.	1. Bring to proper pressure.
	2. Cutting height too low or high.	2. Adjust cutting height.
	3. Engine speed too slow.	3. Move throttle control to "FAST" position.
	4. Forward speed too fast.	4. Move joystick to a slower speed.
	5. Terraced cut, side to side.	5. Adjust side to side level.
	6. Excessive deck pitch, front to rear.	6. Adjust front to rear level.
	7. Cutting blade(s) dull or damaged.	7. Sharpen cutting edges or replace blade(s).
	8. Blade belt slipping.	8. Replace blade belt.
	9. Check electric clutch.	9. Adjust to proper specifications.
	10. Check clutch belt.	10. Replace clutch belt.
	11. Check gearbox for damage.	11. Contact authorized <b>SNAPPER</b> dealer.
<b>Poor Grass Discharge</b>	1. Engine speed too slow.	1. Move throttle control to "FAST" position.
	2. Forward speed too fast.	2. Move joystick to a slower speed.
	3. Grass is wet.	3. Mow when grass is dry.
	4. Excessively worn or damaged blade(s).	4. Service mower blade(s).
	5. Build up of grass clippings and debris under deck.	5. Clean deck.
	6. Improper blade(s) installed on deck.	6. Install proper <b>SNAPPER</b> blades.
	7. Blade(s) installed improperly on deck.	7. Install blades properly.
<b>Battery Will Not Charge</b>	1. Poor cable connections.	1. Clean cables and battery terminals.
	2. Bad battery cell(s).	2. Replace with new battery.
	3. Faulty alternator.	3. Contact engine manufacturer's dealer.
<b>Oil Leaking</b>	1. Loose or missing hydraulic reservoir cap.	1. Check oil level and replace reservoir cap.
	2. Leaking hose fittings, clamps or reservoir.	2. Verify fittings and hose clamps are tight.
<b>Deck Will Not Lift Properly</b>	1. Loose or disconnected electrical harness.	1. Connect electrical harness.
	2. Electric screw jack malfunctioning.	2. Contact authorized <b>SNAPPER</b> dealer.
	3. Key switch is in "OFF" position.	3. Turn key switch to "ON" position.

# SERVICE SCHEDULE

ITEM	SERVICE PERFORMED	REF.	EACH USE	5 HRS	25 HRS	50 HRS	75 HRS	100 HRS	EACH SEASON
<b>Engine Oil</b>	Check Oil Level	Page 9	X						
	Initial Oil Change	Page 15				X			
	Periodic Oil Change	Page 14					X*		
	Change Oil Filter	Engine Manual						X	
<b>Air Cleaner</b>	Clean or Replace	Engine Manual			X**				X
<b>Fuel Filter</b>	Replace	Page 17							X
<b>Engine Cooling System</b>	Clean Radiator Screen & Fins	Engine Manual & Page 15			X**				
<b>Engine Cooling System</b>	Check coolant level	Engine Manual & Page 15			X				
<b>Battery</b>	Check Electrolyte	Page 23-24						X	X
	Charge Battery	Page 23-24							X
	Testing Battery	Pages 24							X
<b>Tires</b>	Check Air Pressure	Page 9	X			X			X
<b>Drive Belts</b>	Check For Wear And Tension	Page 15						X	X
<b>Mower Blades</b>	Check For Wear, Damage & Replacement	Pages 14, 20-21	X						
<b>Mower Deck</b>	Clean Outside & Underside of Debris Accumulation	Page 15	X						
<b>Lubrication Points</b>	Grease or Oil	Pages 15-16			X				X
<b>Hydrostatic Trans. Oil</b>	Check Oil Level	Page 16			X				X
<b>Hydrostatic Trans. Filter</b>	Replace Filter	Page 16							

First Change at 200 Hours.  
Thereafter every 500 Hours.

\*Change oil every 25 hours when operating under heavy load or high temperatures.

\*\* Clean more often under dusty conditions or when air debris is present.

## MAINTENANCE PARTS

### 4.8.1. MAINTENANCE/REPLACEMENT PARTS

<b>MAINTENANCE PARTS</b>	
<b>Mower Blades (52" Deck) (Hi Lift)</b>	<b>2-9246 (3)</b>
<b>Mower Blades (61" Deck) (Low Lift)</b>	<b>1-7081 (3)</b>
<b>Mower Blades (61" Deck) (Hi Lift)</b>	<b>2-9251 (3)</b>
<b>Mower Deck Belt (52" Deck)</b>	<b>4-2776</b>
<b>Mower Deck Belt (61" Deck)</b>	<b>3-5542</b>
<b>Upper Drive Shaft To Hydro Pump Belt</b>	<b>3-5544 (2)</b>
<b>Deck Drive Shaft To Electric Clutch Belt</b>	<b>4-1830 (2)</b>
<b>Battery</b>	<b>3-5610</b>

# **SNAPPER®**

## **2 YEAR LIMITED WARRANTY**

For two (2) years from purchase date for the original purchaser's use, **SNAPPER**, through any authorized **SNAPPER** dealer will replace, free of charge (except for taxes where applicable), any part or parts found upon examination by the factory at McDonough, Georgia, to be defective in material or workmanship or both.

**SNAPPER** FIELD SERVICEABLE SPINDLES and their components used on **SNAPPER PRO®** Mid Size walks and **SNAPPERZRIDER®** ride on commercial equipment have a three (3) year limited warranty against defects in material or workmanship or both.

All transportation costs incurred by the purchaser in submitting material to an authorized **SNAPPER** dealer for replacement under this warranty must be paid by the purchaser.

This warranty does not apply to engines and their components, and batteries, as these items are warranted separately. This warranty does not apply to parts that have been damaged by accident, alteration, abuse, improper lubrication, normal wear, or other cause beyond the control of **SNAPPER**. This warranty does not cover any machine or component that has been altered or modified, changing safety, performance, or durability.

Batteries have a one (1) year prorated warranty period with free replacement if required during the first ninety (90) days from the original purchase date. **SNAPPER** will not be responsible for any installation cost incurred. The battery warranty only covers original equipment batteries and does not cover damage to the battery or machine caused by neglect or abuse, destruction by fire, explosion, freezing, overcharging, improper maintenance, or use of improper electrolyte.

There is no other express warranty.

### **DISCLAIMER OF WARRANTY**

Implied warranties, including those of merchantability and fitness for a particular purpose, are limited to two (2) years from purchase date for the original purchaser's use, and up to the extent permitted by law and all implied warranties are excluded. This is the exclusive remedy. Liabilities for consequential damages, under any and all warranties are excluded.

Some states do not allow limitations on how long an implied warranty lasts, or do not allow the exclusion or limitation of incidental or consequential damages, so the above limitation or exclusion may not apply to you.

This warranty gives you specific legal rights, and you may also have other rights which vary from state to state.

**WARNING: THE USE OF REPLACEMENT PARTS OTHER THAN GENUINE SNAPPER PARTS MAY IMPAIR THE SAFETY OF SNAPPER PRODUCTS AND WILL VOID ANY LIABILITY AND WARRANTY BY SNAPPER ASSOCIATED WITH THE USE OF SUCH PARTS.**

**IMPORTANT:** Please fill out the attached **SNAPPER** Product Registration Card immediately and mail to:  
**Snapper's Product Registration Center, P.O. Box 1379, McDonough, Georgia. 30253**





*Safety Instructions & Operator's Manual for*

# **SNAPPER®**

## **OUT FRONT Z-RIDER HYDRO DRIVE SERIES 0**

### **IMPORTANT**

Snapper products are built using engines that meet or exceed all applicable emissions requirements on the date manufactured. The labels on those engines contain very important emissions information and critical safety warnings. Read, Understand, and Follow all warnings and instructions in this manual, the engine manual, and on the machine, engine and attachments. If you have any questions about your Snapper product, contact your local authorized Snapper dealer or contact Snapper Customer Service at Snapper, McDonough, GA. 30253. Phone: (1-800-935-2967).



**WARNING:** The engine exhaust from this product contains chemicals known to the State of California to cause cancer, birth defects or other reproductive harm.

**SNAPPER®** McDonough, GA., 30253 U.S.A.