

# Safety Instructions & Operator's Manual for

# SNAPPER®

## EUROPEAN LAWN TRACTOR HYDROSTATIC & GEAR DRIVE SERIES D

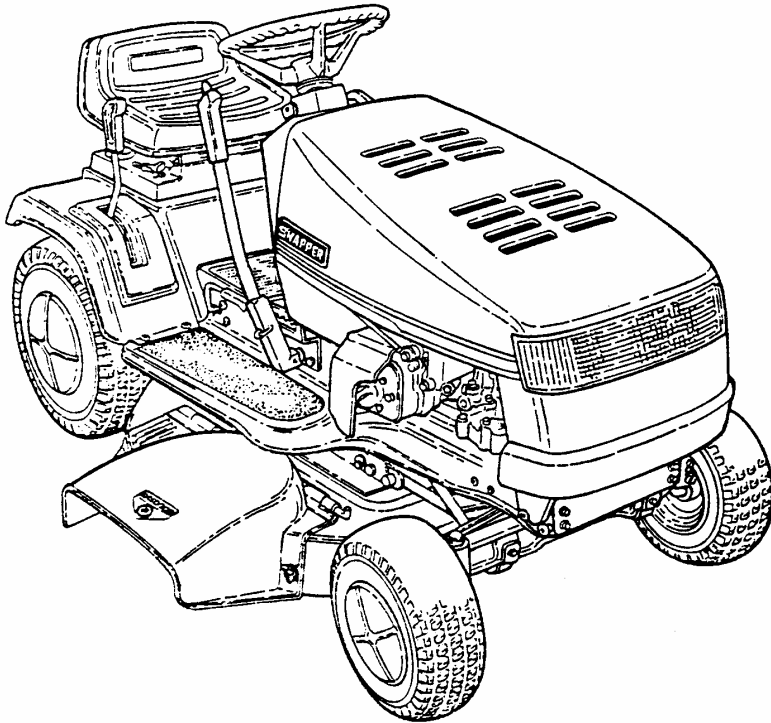

MODELS	
GEAR DRIVE	HYDROSTATIC DRIVE
ELT125G33DB	ELT140H33DBV ELT145H33DBV

### MODEL NUMBER EXPLANATION



E – European Model
LT – Model Designation
125 – 12.5 HP (Engine Horse Power)
140 – 14.0 HP (Engine Horse Power)
145 – 14.5 HP (Engine Horse Power)
H – Hydrostatic Transmission Drive System

33 – 33" Cutting Width Mower Deck
D – Series Designation
B – Briggs & Stratton Engine
V – Over Head Valve Type Engine

**SNAPPER**® McDonough, GA., 30253 U.S.A.

# IMPORTANT SAFETY INSTRUCTIONS

**WARNING:** This powerful cutting machine is capable of amputating hands and feet and can throw objects that can cause injury and damage! Failure to comply with the following SAFETY instructions could result in serious injury or death to the operator or other persons. The owner of the machine must understand these instructions and must allow only persons who understand these instructions to operate machine. Each person operating the machine must be of sound mind and body and must not be under the influence of any substance, which might impair vision, dexterity or judgment. If you have any questions pertaining to your machine which your dealer cannot answer to your satisfaction, call or write the Customer Service Department at SNAPPER , McDonough, Georgia 30253. Phone: (1-800-935-2967).

## PROTECTION FOR CHILDREN

Tragic accidents can occur if the operator is not alert to the presence of children. Children are often attracted to the machine and the mowing activity. Never assume that children will remain where you last saw them.

1. KEEP children out of the mowing area and under the watchful care of a responsible adult.
2. DO NOT allow children in yard when machine is operated (even with the blade OFF).
3. DO NOT allow children or other passengers to ride on machine or on attachments (even with the blade OFF). They may fall and be seriously injured.
4. DO NOT allow pre-teenage children to operate machine.
5. ALLOW only responsible adults & teenagers with mature judgment under close adult supervision to operate machine.
6. BE SURE the area is clear of others before mowing and turn machine OFF if anyone enters the area.
7. DO NOT mow in reverse unless absolutely necessary. LOOK BEHIND and down for small children before and when backing.
8. USE EXTRA CARE when approaching blind corners, shrubs, trees, or other objects that may obscure vision.

## PROTECTION AGAINST TIPOVERS

Slopes are a major factor related to loss-of-control and tip-over accidents, which can result in severe injury or death. All slopes require extra CAUTION. If you cannot back up the slope or if you feel uneasy on it, DO NOT mow it. Use extra care with grass catchers or other attachments; these can change the stability of the machine.

1. DO NOT operate machine on slopes exceeding 15 degrees (27% grade).
2. Exercise EXTREME CAUTION on slopes above 10 degrees (18% grade). Turn blade OFF when traveling uphill. Use first speed and avoid sudden or sharp turns.
3. DO NOT mow back and forth across face of slopes. Mow up and down.

## PROTECTION AGAINST TIPOVERS

(Continued From Previous Column)

4. AVOID uphill starts. If machine stops going uphill or tires lose traction, turn blade OFF and back slowly down the slope.
5. STAY ALERT for holes and other hidden hazards. Tall grass can hide obstacles. Keep away from ditches, washouts, culverts, fences and protruding objects.
6. KEEP A SAFE DISTANCE (at least 3 feet) away from edge of ditches and other drop offs. The mower could turn over if an edge caves in.
7. Always begin forward motion in the #1 speed position.
8. Use weights or a weighted load carrier in accordance with instructions supplied with a grass catcher.
9. DO NOT put your foot on the ground to try to stabilize the machine.
10. DO NOT mow on wet grass. Reduced traction could cause sliding.
11. DO NOT mow under any condition where traction, steering or stability is doubtful without first test driving over the terrain with blade OFF.

## PREPARATION

1. Read this manual, get to know where all controls are located and practice how to use them before starting for the first time, and at the beginning of each season. Read and follow Warnings and Instructions on engine and machine. Read and follow operator's manual and instructions furnished with attachments.
2. Only mature, responsible persons shall operate the machine and only after proper instruction.
3. Data indicates that operators age 60 and above, are involved in a large percentage of mower-related injuries. These operators should evaluate their ability to operate the mower safely enough to protect themselves and others from serious injury.

# IMPORTANT SAFETY INSTRUCTIONS

## PREPARATION

(Continued From Previous Page)

4. Handle fuel with extra care. Fuels are flammable and vapors are explosive. Use only an approved fuel container. Never remove fuel cap or add fuel with engine running. Add fuel outdoors only with engine stopped and cool. Clean spilled fuel from machine. **DO NOT** smoke.
5. Practice operation of machine with **BLADE OFF** to learn controls and develop skills.
6. Check the area to be mowed and remove all objects such as toys, wire, rocks, limbs and other objects that could cause injury if thrown by blade or interfere with mowing.
7. Keep people and pets a safe distance from machine.
8. Check shields, deflectors, switches, blade controls and other safety devices frequently for proper operation and location.
9. Make sure all safety decals are clearly legible. Replace if damaged.
10. Protect yourself when mowing and wear safety glasses, long pants and substantial footwear.
11. Know how to **STOP** blade and engine quickly in preparation for emergencies.
12. Use extra care when loading or unloading the machine into a trailer or truck.
13. Check grass catcher components frequently for signs of wear or deterioration and replace as needed to prevent injury from thrown objects going through weak or worn spots.

## OPERATION

1. Mount and dismount machine from left side.
2. Start engine from operator's seat, if possible. Make sure blade is **OFF** and parking brake is set.
3. **STOP** blade, **STOP** engine, set parking brake and remove key when leaving machine.
4. **DO NOT** operate machine unless properly seated with feet on feet rests or pedal(s).
5. **STOP BLADE** and **ENGINE** and make sure blade has stopped before removing grass catcher or unclogging mower to prevent loss of fingers or hand.
6. Blade must be **OFF** except when cutting grass. Set blade in highest position when mowing over rough ground.
7. Keep hands and feet away from rotating blade underneath deck. **NEVER** place foot on ground while **BLADE** is **ON** or machine is in motion.
8. Deflector or entire grass catcher must be in place. **NEVER** point discharge at people, passing cars, windows or doors.
9. Slow down before turning.
10. Watch out for traffic when near or crossing roadways.
11. **STOP** engine immediately after striking an obstruction. Inspect machine and repair damage before resuming operation.

## OPERATION

(Continued From Previous Column)

12. Mow only in daylight or with good artificial light.
13. Move joystick (if equipped) **SLOWLY** to maintain control during speed and directional changes.
14. Exercise **CAUTION** when pulling loads. Limit loads to those you can safely control and attach loads to hitch plate as specified with **SNAPPER** attachment instructions.

## MAINTENANCE

1. Never store machine or fuel container inside where fumes may reach an open flame, spark or pilot light such as in a water heater, furnace, clothes dryer or other gas appliance. Allow engine to cool before storing machine in an enclosure. Store fuel container out of the reach of children in a well ventilated, unoccupied building.
2. Keep engine free of grass, leaves or excess grease to reduce fire hazard and engine overheating.
3. When draining fuel tank, drain fuel into an approved container outdoors and away from open flame.
4. Check brakes frequently; adjust, repair or replace as needed.
5. Keep all bolts, nuts and screws properly tight. Check that all cotter pins are in proper position.
6. Always provide adequate ventilation when running engine indoors. Exhaust gases contain carbon monoxide, an odorless and deadly poison.
7. Disconnect negative (black) cable from battery before performing maintenance or service. Cranking engine could cause injury.
8. Never work under machine without safety blocks.
9. Service engine and make adjustments only when engine is stopped. Remove spark plug wire(s) from spark plug(s) and secure wire(s) away from spark plug(s).
10. **DO NOT** change engine governor speed settings or overspeed engine.
11. Lubricate machine at intervals specified in manual to prevent controls from binding.
12. Mower blades are sharp and can cut. Wrap the blades or wear heavy leather gloves and use **CAUTION** when handling them.
13. **NEVER** test for spark by grounding spark plug next to spark plug hole; spark plug could ignite gas exiting engine.
14. Have machine serviced by an authorized **SNAPPER** dealer at least once a year and have the dealer install any new safety devices.
15. Use only genuine **SNAPPER** replacement parts to assure that original standards are maintained.

# TABLE OF CONTENTS

<b>IMPORTANT SAFETY INSTRUCTIONS.....</b>	<b>2-3</b>	<b>MAINTENANCE INSTRUCTIONS (Continued)</b>	
<b>TABLE OF CONTENTS.....</b>	<b>4</b>	<b>Battery Service.....</b>	<b>21-22</b>
<b>FAMILIARIZATION.....</b>	<b>5-6</b>	<b>Battery Electrolyte Check.....</b>	<b>21</b>
Location of Controls & Components .....	5	Battery Removal.....	21
Decals .....	6	Battery Charging.....	22
<b>OPERATING INSTRUCTIONS .....</b>	<b>7-12</b>	<b>Mower Deck Removal/Reinstallation.....</b>	<b>23</b>
Pre-start Checklist .....	7	<b>Standard Mower Blade Service.....</b>	<b>26-27</b>
Adjusting Operator's Seat .....	7	Standard Blade Wear Limits .....	26
Starting & Stopping Engine .....	8	Blade Removal/Replacement.....	26
Starting & Stopping Wheel Drive.....	9	Sharpening Standard Blade(s) .....	27
Starting & Stopping Mower Blades.....	10	<b>Ninja Mower Blade Service.....</b>	<b>27-28</b>
Setting & Releasing Parking Brake .....	10	Ninja Blade Wear Limits.....	27
Rolling Tractor With Engine Off.....	10	Ninja Blade Sharpening .....	27-28
Raising Chute Deflector .....	11	<b>Belt Service .....</b>	<b>22-26</b>
Adjusting Cutting Height.....	11	Mower Drive Belt Removal/Replacement .....	22
Tips on Mowing .....	12	Traction Drive Belt Service .....	22-23
<b>ACCESSORIES.....</b>	<b>12</b>	Traction Drive Belt Removal.....	24
<b>TROUBLESHOOTING GUIDE .....</b>	<b>13-14</b>	Traction Drive Belt Replacement.....	25
<b>MAINTENANCE INSTRUCTIONS .....</b>	<b>15-34</b>	Traction Drive Belt Adjustment.....	28-29
<b>Service Schedule .....</b>	<b>15</b>	<b>Deck Level Adjustment.....</b>	<b>30-33</b>
<b>Maintenance Parts .....</b>	<b>15</b>	Side to Side Level.....	30-31
<b>Hydrostatic Transmission Oil.....</b>	<b>16</b>	Front to Rear Level .....	31-32
To Check Oil Level.....	16	Sector Plates .....	31
<b>Changing Engine Oil .....</b>	<b>17</b>	Front Lift Rod.....	32
<b>Lubrication (Tractor) .....</b>	<b>18-19</b>	<b>Steering Adjustment .....</b>	<b>33</b>
Front Wheel Bearings .....	18	<b>Shifter Adjustment .....</b>	<b>33</b>
Axle Spindles .....	18	<b>Wheel Brake Adjustment .....</b>	<b>34</b>
Steering Shaft .....	18	<b>ELECTRICAL SYSTEM.....</b>	<b>35-36</b>
Clutch/Brake Pivot.....	18	Harness Routing.....	35
Steering Sector Gear .....	18	SCHEMATIC, Briggs Engine w/o lights.....	36
Steering Drag Link .....	19	SCHEMATIC, Briggs Engine w/lights.....	36
Steering Tie Rod .....	19	<b>WARRANTY .....</b>	<b>39</b>
Park Brake Latch .....	19		
Deck Lift Mechanism.....	19		
Blade Engagement Mechanism .....	19		
<b>Engine Service.....</b>	<b>20</b>		
Engine Air Pre-Cleaner .....	20		
Engine Air Cleaner .....	20		
Spark Plug.....	20		
Fuel Filter .....	20		
Engine Cooling System.....	21		

# FAMILIARIZATION

## COMPONENTS

The nomenclature drawings, Figures 2 & 3, illustrate essential components of the SNAPPER Series D Lawn Tractors. It is recommended that all operators of this equipment become thoroughly familiar with the components and their operation **BEFORE OPERATING**. Specific details involving the engine are found in the separate Engine Owner's Manual. Study the Important Safety Instructions, this Operator's Manual and Engine Owner's Manual **before** operating this machine. Keep these manuals available for future reference.

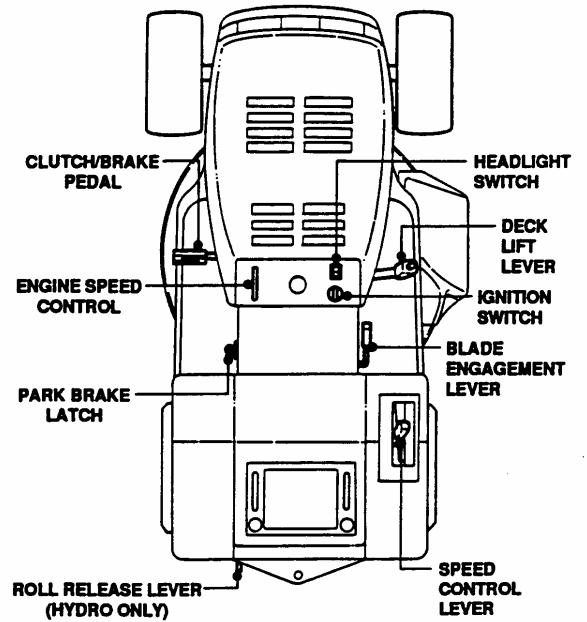

FIGURE 2

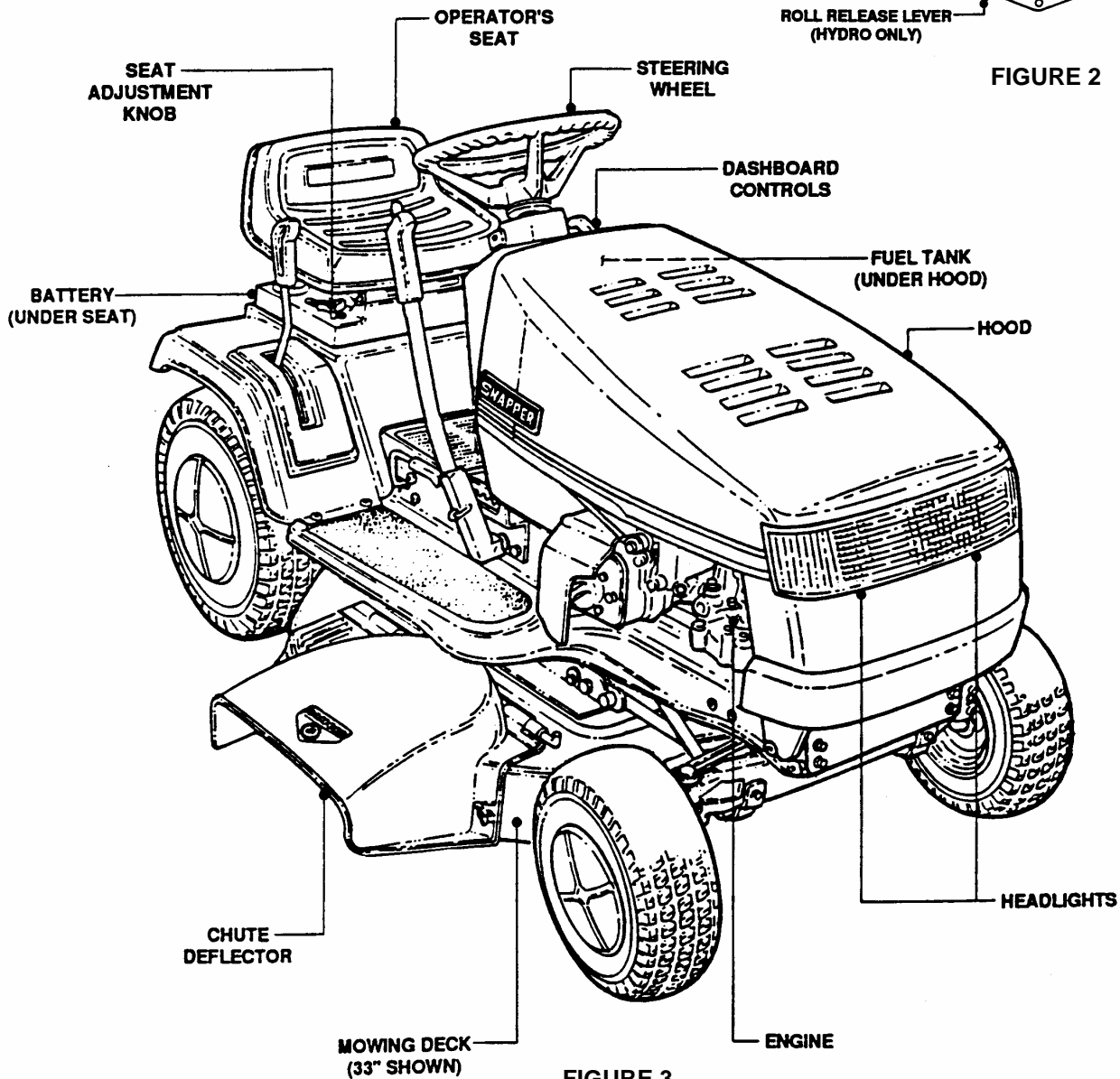

FIGURE 3

# FAMILIARIZATION

## DECALS

All operators should locate, read and understand all decals on the Series D Lawn Tractor before attempting any operation of the tractor. If an operator has difficulty in understanding certain symbols incorporated in the decals, an authorized SNAPPER dealer should be contacted for explanation.



CAUTION DECAL  
16973

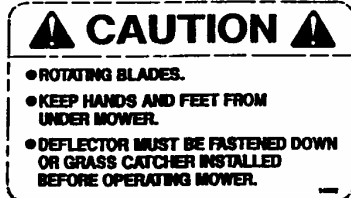

CAUTION DECAL  
14852

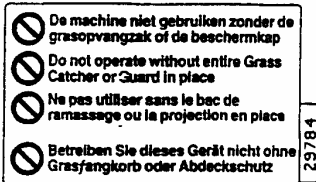

CHUTE WARNING DECAL  
29784



CAUTION TAG  
16134

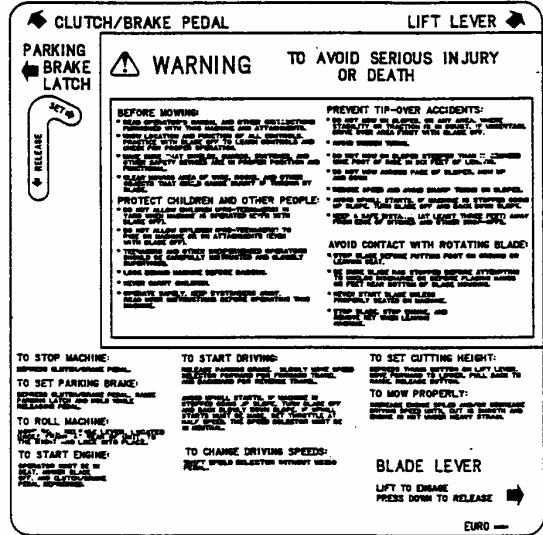

FRAME INSTRUCTION DECAL

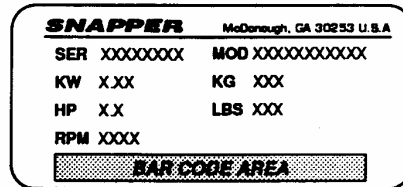

SERIAL NUMBER  
DECAL 001015



YEAR OF MANUFACTURE  
DECAL 28515



CAUTION DECAL  
26415

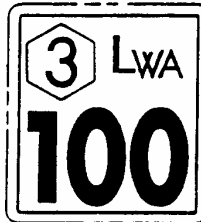

EUROPEAN NOISE CONTROL  
DECAL 23009

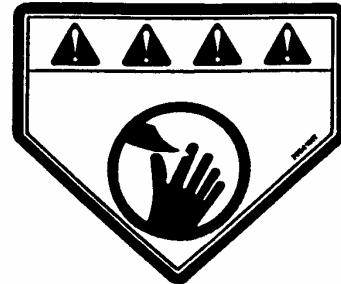

WARNING DECAL  
22841



YEAR OF MANUFACTURE  
DECAL 29878



EUROPEAN COMMUNITY  
DECAL 29776



YEAR OF MANUFACTURE  
DECAL 29077

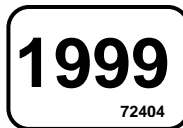

CPS DECAL  
26831



LOGO DECAL

# OPERATING INSTRUCTIONS

## PRE-START CHECKLIST

Make the following checks and perform service as required before each start-up.

Check tires and add air as needed to bring pressure to 12psi in front tires and 10 psi in rear tires.

Check guards, deflectors and covers to make sure all are in place and securely tightened. If guards are missing or damaged, replace before operating mower.

Check engine oil. Add oil as needed to bring up to, but not over, the full mark. Refer to the engine owner's manual for oil specifications.

Check operator's seat adjustment. Adjust as necessary.

Check blade engagement lever to insure it operates properly. The blade engagement lever must be moved manually from "ON" to "OFF" to stop blade.

Clean exterior surfaces of cutting deck, engine and tractor from any accumulation of grass clippings and debris. Keep engine air intake screens and cooling fins clean at all times.

With engine "OFF" move the tractor outside and add fuel to the fuel tank. Securely tighten fuel cap after refueling. See Figure 4. Refer to engine owner's manual for fuel specifications.

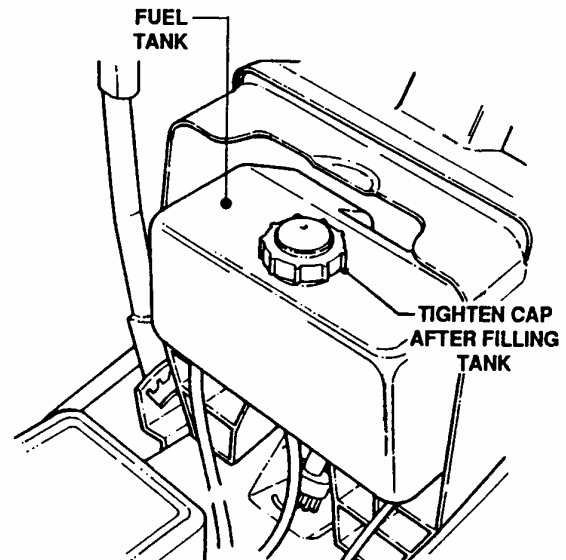

FIGURE 4

## ADJUSTING OPERATOR'S SEAT

### FRONT TO REAR ADJUSTMENT

With engine "OFF", raise operator's seat and loosen the two adjusting knobs on the seat support. See Figure 5.

Lower the seat.

Sit in the operator's seat and slide the seat forward or backward until the clutch/brake pedal can be fully depressed comfortably.

Raise seat and tighten the adjusting knobs to secure seat in position.

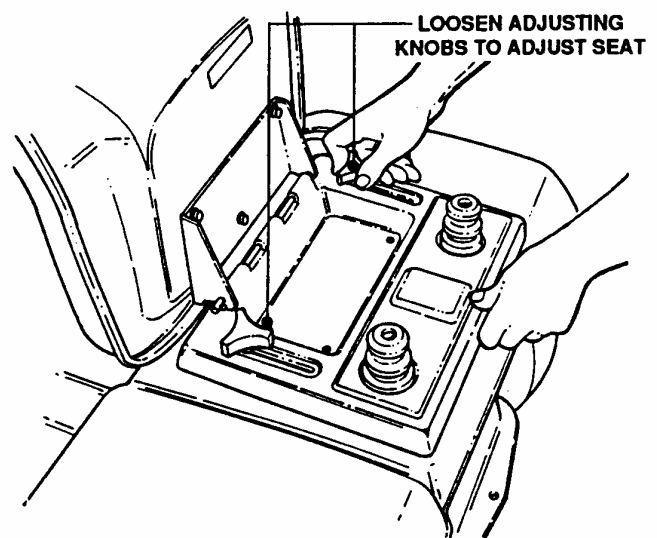

FIGURE 5

# OPERATING INSTRUCTIONS

## STARTING & STOPPING ENGINE

### STARTING ENGINE

Take a comfortable position in seat of riding mower, look around to make sure that the area you are going to mow is clear of people, children, pets and debris. Take note of any stationary obstacles!

---

**NOTE:**

The interlock system will prevent the engine from starting if the blade engagement lever is in the "ON" (up) position. If the interlock system ever fails to work, **DO NOT OPERATE** the tractor until the interlock has been repaired.

---

Push blade engagement lever down to the "OFF" position. See Figure 6.

Depress the clutch/brake pedal fully. See Figure 7.

---

**NOTE:**

The seat interlock will shut off the engine if the operator gets off the seat without setting the parking brake lever or if the blade is running. If the interlock ever fails to work, **DO NOT OPERATE** the tractor until the interlock has been repaired.

---

Choke engine for cold starting by moving engine speed control to "CHOKE" (☒) position. Little or no choking will be needed when restarting a warm engine. See Figure 8.

Insert key in switch.

Turn key to "START" (Ⓚ) position to crank engine and hold until engine starts, then release key.

---

**NOTE:**

DO NOT crank engine for more than fifteen seconds per minute (15 seconds on 45 seconds off). This will help prevent the starter from overheating and/or running down the battery. If cranking time is more than fifteen seconds, locate and correct cause of starting problem.

---

After engine starts, release key, move the engine speed control to the "FAST" (☑) position and allow engine to warm up before proceeding. See Figure 8.

---

### STOP ENGINE

Move engine speed control to "SLOW" (☐) and turn key to "STOP" (Ⓚ). See Figure 8.

---

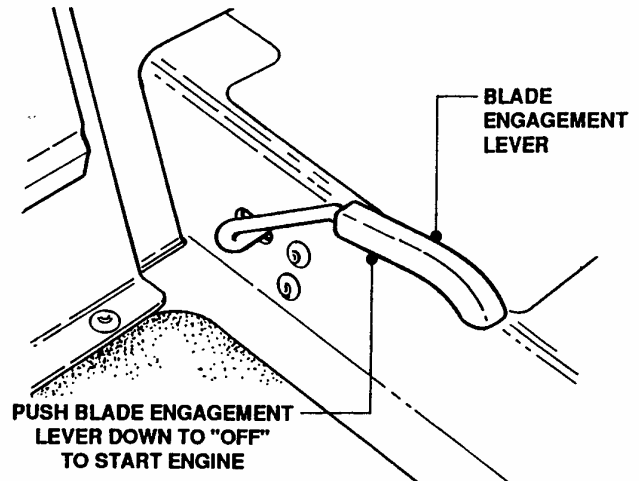

FIGURE 6

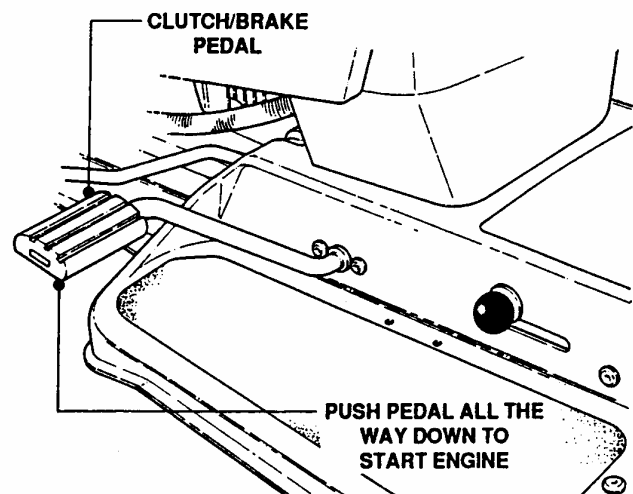

FIGURE 7

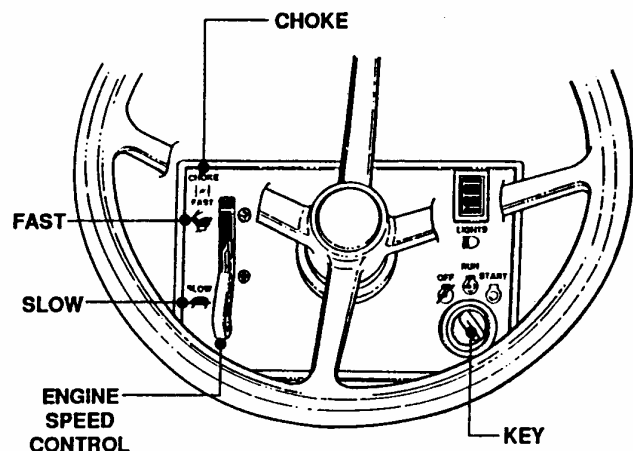

FIGURE 8



# OPERATING INSTRUCTIONS

## STARTING & STOPPING WHEEL DRIVE

### STARTING WHEEL DRIVE OF Model ELT140H33DBV

Depress clutch/brake pedal and set park brake. See Figure 13.

Shift speed control lever to neutral ( N ).

Start engine.

Release brake pedal.

Slowly shift speed control lever forward for forward motion or to the rear for reverse motion. See Figure 9.

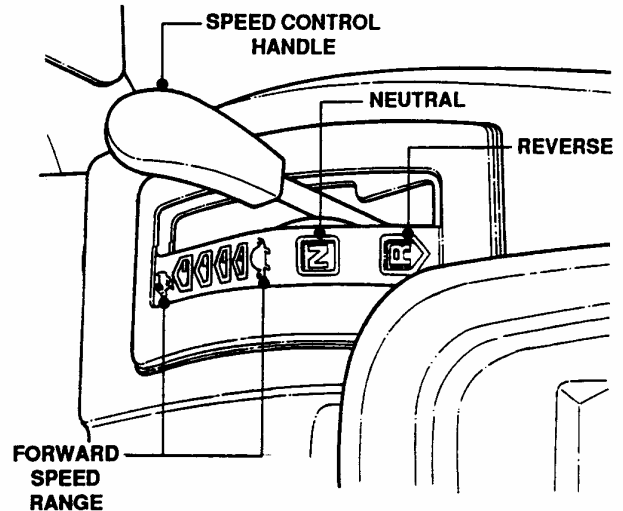

FIGURE 9

### STOPPING WHEEL DRIVE

Fully depress clutch/brake pedal and/or move speed control handle to neutral (N) to stop wheel drive. See Figure 10.

#### NOTE:

When the tractor is moving forward and the clutch/brake pedal is pushed all the way down, the speed control handle will automatically return to approximately 1/3 of full forward speed. Move handle to neutral (N) position before releasing brake pedal.

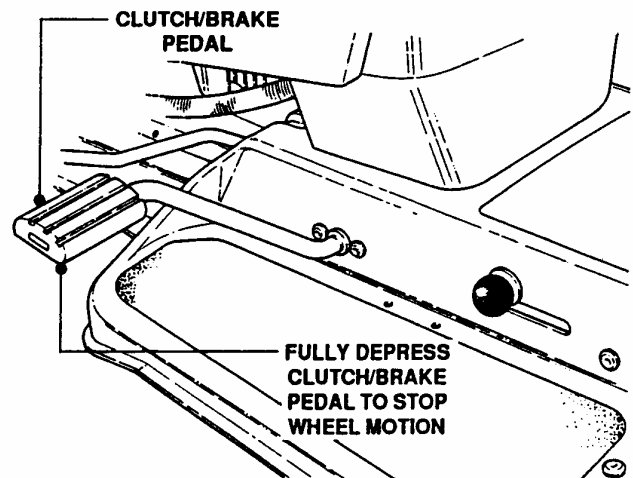

FIGURE 10

### STARTING WHEEL DRIVE OF Model ELT125G33DB

Depress clutch/brake pedal and set park brake. See Figure 13.

Shift speed control lever to neutral ( N ).

Start engine.

Move speed control handle forward to desired forward speed or backward to reverse. See Figure 11.

Slowly release clutch/brake pedal to begin motion.

#### NOTE:

The clutch/brake pedal must be fully depressed when changing speed.

Fully depress clutch/brake pedal to stop wheel drive. See Figure 10.

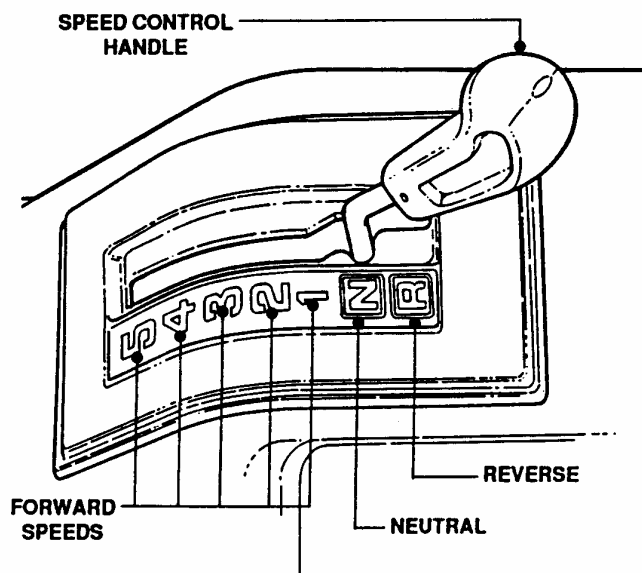

FIGURE 11

# OPERATING INSTRUCTIONS

## STARTING & STOPPING MOWER BLADE

### STARTING MOWER BLADE

Start engine.

Raise blade engagement lever to "ON". See Figure 12.

### STOPPING MOWER BLADE

Move blade engagement lever to "OFF". See Figure 12.

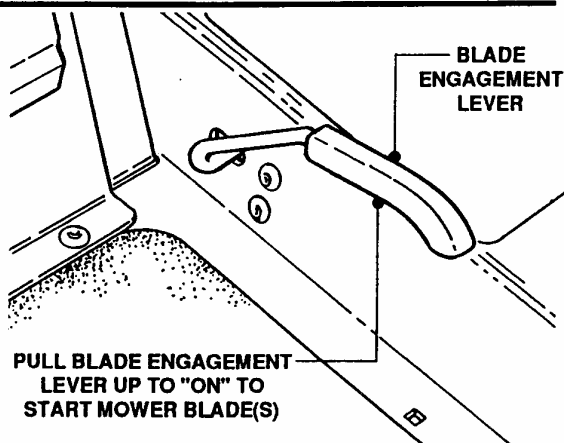

FIGURE 12

## SETTING & RELEASING PARK BRAKE

### SETTING PARK BRAKE

Fully depress clutch/brake pedal.

Move park brake lever up into notch at front of slot. See Figure 13.

Release clutch/brake pedal.

### RELEASING PARK BRAKE

Fully depress clutch/brake pedal. The park brake lever will release automatically.

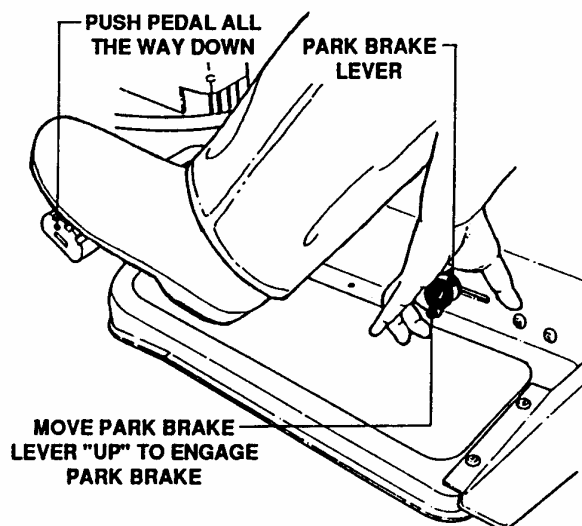

FIGURE 13

## ROLLING TRACTOR WITH ENGINE OFF

### ROLLING Model ELT140H33DBV

With engine "OFF", move to rear of tractor.

Move the roll release control to the right and down. This disengages the hydro transmission. See Figure 14.

Release the park brake and move tractor to desired location.

Move roll release control up and to the left to engage hydro transmission.

Set park brake.

### NOTE:

The transmission will not propel the tractor if the roll release lever is left in the "ROLL" position.

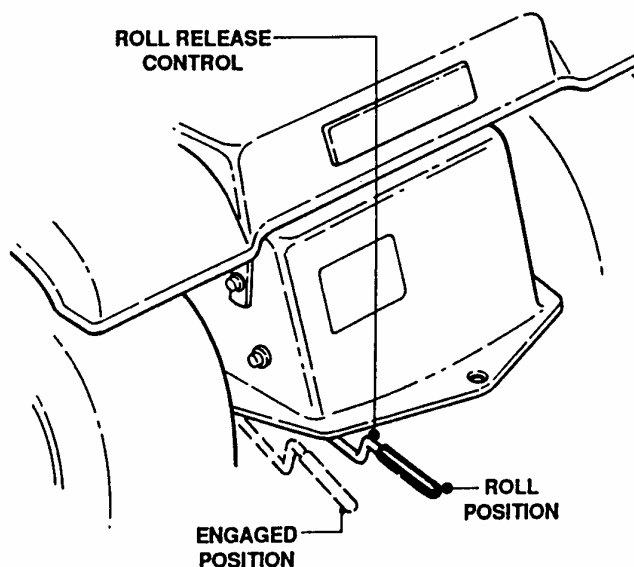

FIGURE 14

# OPERATING INSTRUCTIONS

## ROLLING GEAR DRIVE MODELS

With engine "OFF", fully depress clutch/brake pedal.

Place speed control lever in the neutral ( N ) position. See Figure 15.

Release clutch/brake pedal and move tractor to desired location.

Set park brake.

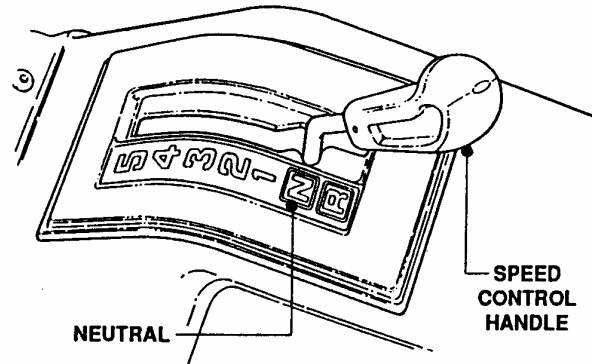

FIGURE 15

## RAISING CHUTE DEFLECTOR

### RAISING CHUTE DEFLECTOR for CLEARANCE THROUGH GATES or for TRANSPORTS

Remove wing nuts and flat washers, securing chute deflector to deck. See Figure 16.

Raise chute deflector and reinstall flat washers and wing nuts onto studs to prevent loss.

Transport tractor to desired location.

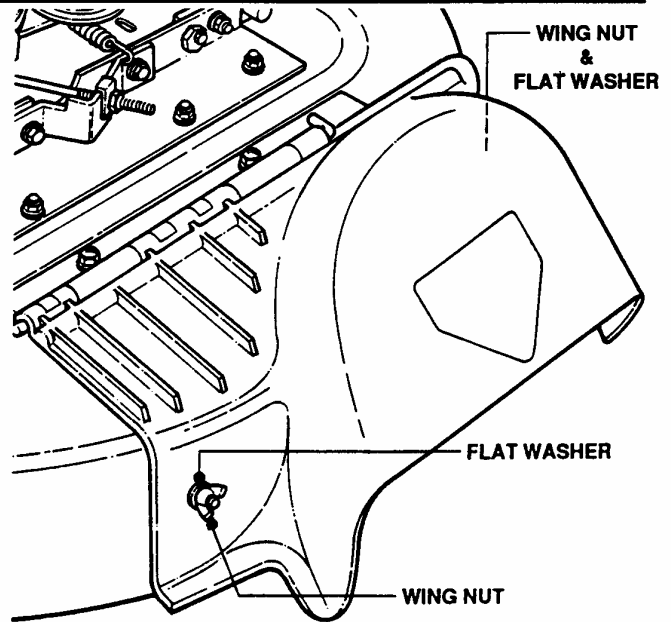

FIGURE 16

**WARNING**

*Never attempt to operate mower without chute deflector secured in the down position.*

## ADJUSTING CUTTING HEIGHT

### ADJUST CUTTING HEIGHT for all DECKS

Depress lock button on deck lift lever. See Figure 17.

Raise or lower deck to any of six positions as desired.

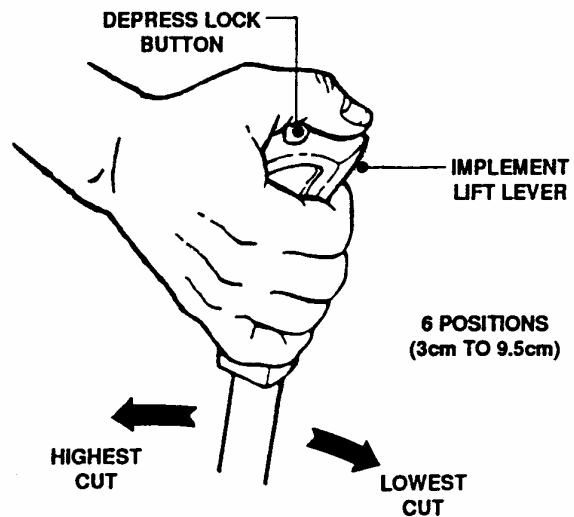

FIGURE 17

# OPERATING INSTRUCTIONS

## TIPS ON MOWING

For best results, use the following tips when mowing.

When mowing, cut only 1/3 of grass height. Cutting grass shorter could be harmful to your lawn.



If cutting extremely tall grass, make one cutting with the deck in its highest cutting position, then lower deck to desired position and a second cut.

Mow when lawn is dry.

Mow often. Shorter grass clippings decompose quicker.

Keep mower blades sharp. A dull blade tears and shreds grass instead of cutting. Your SNAPPER dealer can sharpen blades as required.

Alternate mowing pattern to reduce the possibility of grass matting.

Mow with engine speed control in the "FAST"  position and speed control handle in a "SLOW"  position.

Clean deck, removing all grass clippings and debris from the top and underside of deck after each use.

## AVAILABLE ACCESSORIES

The SNAPPER Series D LAWN TRACTOR can be equipped with a variety of accessories that increase its versatility. The accessories available for each model are listed in the chart below. Contact an authorized SNAPPER dealer for ordering any of the accessories desired.

AVAILABLE ACCESSORIES	SERIES D LAWN TRACTOR MODEL			
	ELT125G33DB	ELT140H33DBV		
Thatcherizer	61247	61247		
Snow Blade*	NA	61352		
Dozer Blade Support Kit	NA	61370		
2-Stage Snow Thrower**	NA	80560		
Snow Thrower Support Kit	NA	61371		
Weight Kit	NA	61245		
Tire Chains	NA	61085		
Ninja™ Kit	61255	61255		
Single Bag Catcher	60943	60943		
Dump Cart	60697	60697		
Twin Bag Catcher	60946	60946		
Adaptor Mounting Kit	61334	61334		
Gage Wheel Kit	NA	NA		
Bag-N-Wagon	60947	60947		
Bag-N-Wagon Hitch Kit	61308	61308		

\* Requires Dozer Blade Support Kit

\*\* Requires Snow Thrower Support Kit

# TROUBLESHOOTING

<b>PROBLEM</b>	<b>PROBABLE CAUSE</b>	<b>CORRECTIVE ACTION</b>	<b>REF.</b>
<b>STARTER WILL NOT CRANK ENGINE</b>	1. Battery dead.	1. Service battery.	Pg. 22
	2. Blown fuse.	2. Replace fuse.	Pg. 35
	3. Electrical connections loose or corroded.	3. Clean and check connections for good contact.	Pg. 35
	4. Defective ignition switch.	4. Contact authorized SNAPPER dealer.	Yellow Pages
<b>ENGINE WILL NOT START</b>	1. Blade engagement lever in the "ON" position.	1. Move blade engagement lever to "OFF"	Pg. 10
	2. Park brake not set.	2. Set park brake.	Pg. 10
	3. Fuel tank empty.	3. Fill fuel tank with fresh fuel.	Pg. 7
	4. Engine needs choking.	4. Move engine speed control to "CHOKE".	Pg. 8
	5. Spark plug wire disconnected.	5. Place spark plug wire onto spark plug.	Engine Man.
	6. Battery weak or dead.	6. Service battery.	Pg. 21-22
	7. Faulty interlock switch.	7. Contact authorized SNAPPER dealer.	Yellow Pages
<b>ENGINE STALLS AFTER RUNNING</b>	1. Operator not in seat.	1. Sit in operator's seat.	Pg. 8
	2. Engine speed control in the "CHOKE" position.	2. Move engine speed control to "FAST".	Pg. 8
	3. Fuel tank empty.	3. Refill fuel tank with fresh fuel.	Pg. 7
	4. Engine air pre-cleaner and or air cleaner dirty.	4. Clean or replace filters.	Pg. 20
	5. Spark plug defective or gap set improperly.	5. Service spark plug.	Engine Man.
	6. Fuel filter stopped up.	6. Replace fuel filter.	Pg. 20
	7. Water, debris or stale fuel in fuel system.	7. Drain and clean fuel system.	Engine Man.
<b>ENGINE LOSES POWER</b>	1. Excessive load on engine.	1. Lessen load.	—
	2. Engine air pre-cleaner or air cleaner dirty.	2. Clean or replace filters.	Pg. 20
	3. Engine oil level low.	3. Fill with engine oil to proper level.	Engine Man.
	4. Engine cooling fins and air screens excessively dirty.	4. Clean free of all debris.	Engine Man.
	5. Spark plug faulty.	5. Service spark plug.	Engine Man.
	6. Water, debris or stale fuel in fuel system.	6. Drain and clean fuel system.	Engine Man.
<b>ENGINE BACKFIRES WHEN IGNITION KEY TURNED TO "STOP"</b>	1. Engine speed control set too "FAST".	1. Set engine speed control to "SLOW" and allow engine to idle. Then, turn key to "OFF".	Pg. 8
<b>EXCESSIVE VIBRATION</b>	1. Damaged or bent mower blades.	1. Service mower blade(s).	Pg. 26-27
	2. Loose blade components.	2. Service and tighten loose parts.	Pg. 26-27
	3. Loose or missing air lift (if equipped).	3. Replace air lifts. Tighten to proper torque.	—
<b>TRACTOR WILL NOT MOVE OR LOSS OF TRACTION</b>	1. Speed control handle in the neutral "N" position.	1. Place speed control in desired speed.	Pg. 9
	2. Roll release control in "ROLL" position. (Hydro Models Only)	2. Move roll release control to the engaged position.	Pg. 10
	3. Low transmission oil level. (Hydro models only)	3. Bring oil to proper level.	Pg. 16
	4. Shifter out of adjustment.	4. Adjust shifter.	Pg. 33
	5. Traction drive belt requires adjustment.	5. Adjust traction drive belt.	Pg. 28-29
	6. Traction drive belt requires replacement.	6. Replace traction drive belt.	Pg. 22-23

# TROUBLESHOOTING

<b>PROBLEM</b>	<b>PROBABLE CAUSE</b>	<b>CORRECTIVE ACTION</b>	<b>REF.</b>
<b>BLADE(S) NOT CUTTING</b>	1. Blade engagement lever in the "OFF" position.	1. Move lever to the "ON" position.	<b>Pg. 10</b>
	2. Blade belt requires adjustment.	2. Adjust mower belt.	<b>Pg. 29-30</b>
	3. Blade belt requires replacement.	3. Replace mower belt.	<b>Pg. 26</b>
<b>CUTTING GRASS IMPROPERLY</b>	1. Uneven tire pressure.	1. Bring to proper pressure.	<b>Pg. 7</b>
	2. Cutting height too low or high.	2. Adjust cutting height.	<b>Pg. 11</b>
	3. Engine speed too slow.	3. Move engine speed control to "FAST".	<b>Pg. 12</b>
	4. Forward speed too fast.	4. Move speed control to a slower speed.	<b>Pg. 12</b>
	5. Deck side to side level requires adjustment.	5. Adjust side to side level.	<b>Pg. 30-31</b>
	6. Deck front to rear level requires adjustment.	6. Adjust front to rear level.	<b>Pg. 31-32</b>
	7. Blade belt requires adjustment.	7. Adjust blade belt tension.	<b>Pg. 29-30</b>
	8. Blade belt requires replacement.	8. Replace blade belt.	<b>Pg. 26</b>
<b>POOR GRASS DISCHARGE</b>	1. Engine speed too slow.	1. Move engine speed control to "FAST".	<b>Pg. 12</b>
	2. Forward speed too fast.	2. Move speed control to a slower speed.	<b>Pg. 12</b>
	3. Grass is wet.	3. Mow when grass is dry.	<b>Pg. 12</b>
	4. Excessively worn or damaged blade(s).	4. Service mower blade(s).	<b>Pg. 26-27</b>
	5. Build-up of grass clippings and debris under deck.	5. Clean deck.	<b>Pg. 7 &amp; 12</b>
	6. Improper blade(s) installed on deck.	6. Install proper SNAPPER blades.	<b>Pg. 15</b>
	7. Blade(s) installed improperly on deck.	7. Install blades properly.	<b>Pg. 27</b>
<b>BATTERY WILL NOT CHARGE</b>	1. Poor cable connections.	1. Clean cables and battery terminals.	<b>Pg. 35</b>
	2. Bad battery cell(s).	2. Replace with new battery.	<b>Pg. 15 &amp; 21</b>
	3. Faulty alternator.	3. Contact engine manufacturer's dealer.	<b>Yellow Pages</b>
<b>OIL LEAKING FROM TRANSMISSION</b>	1. Loose or missing oil filler cap. (Hydro Models Only)	1. Check oil level and replace oil cap.	<b>Pg. 16</b>
	2. Leaking axle seals.	2. Contact authorized SNAPPER dealer.	<b>Yellow Pages</b>
	3. Leaking at casing seal.	3. Contact authorized SNAPPER dealer.	<b>Yellow Pages</b>

# MAINTENANCE INSTRUCTIONS

## SERVICE SCHEDULE

ITEM	SERVICE PERFORMED	REF.	EACH USE	5 HOURS	25 HOURS	50 HOURS	100 HOURS	EACH SEASON
Engine Oil	Check Oil Level	Pg. 7	X					
	Initial Oil Change	Pg. 17		X				
	Periodic Oil Change	Pg. 17				X*		
Air Pre-Cleaner	Clean Sponge Element	Eng. Man.			X**			
Air Cleaner	Clean or Replace	Eng. Man.			X**			
Spark Plug	Replace	Eng. Man.					X	
Fuel Filter	Replace	Pg. 20					X	
Engine Cooling System	Clean Engine Shroud	Pg. 21					X**	
	Clean Cooling Fins	Eng. Man.					X**	
Battery	Check Electrolyte	Pg. 21-22			X			X
	Charge Battery	Pg. 22						X
Tires	Check Pressures	Pg. 7	X					X
Belts	Check for Wear and Tension	Pg. 22-26			X			X
Mower Blades	Check for Wear and Damage	Pg. 26-27	X					
Mower Deck	Check Debris Accumulation Clean Outside & Underside	Pg. 7	X		X			X
Lubrication Points	Grease or Oil	Pg. 18-19			X			X
Hydrostatic Transmission Oil	Check Oil Level	Pg. 16						X

\* Change oil every 25 hours when operating under heavy load or high temperatures.

\*\* Clean more often under dusty conditions or when air debris is present.

## MAINTENANCE PARTS

MODEL	BELTS		BLADES		BATTERY
	TRACTION DRIVE	DECK DRIVE	STANDARD	NINJA™	
ELT125G33DB	29641	26546	19523	24741	60618
ELT140H33DBV	29641	26546	19523	24741	60618

# MAINTENANCE INSTRUCTIONS

## HYDROSTATIC TRANSMISSION OIL

The hydrostatic transmission does not normally require maintenance, however, proper oil level should be verified after every season.

### TO CHECK OIL LEVEL IN TRANSMISSION

Remove seat by removing seat adjustment knobs. See Figure 18.



Lay seat forward. Be careful not to pull seat switch wires from the switch.

Disconnect negative (black) battery wire from terminal first! See Figure 19.

Disconnect positive (red) battery wire from terminal last!

Remove battery and battery tray. Transmission is now accessible.

Clean any debris off of oil cap and top cover before removing fill cap. See Figure 20.

	<b>CAUTION</b>	
<i>MAKE SURE that fill cap and surrounding area are CLEAN before removing fill cap!</i>		

Visually check oil level.

Oil level should be approximately 19mm ( $\pm 6$ mm) from top of case. If the level is lower than 19mm, add 10W 30 motor oil to bring the level up as required.

Replace fill cap.

Reinstall battery tray.

Reinstall battery. See Figure 19.

Reinstall and adjust seat. See Figure 18.

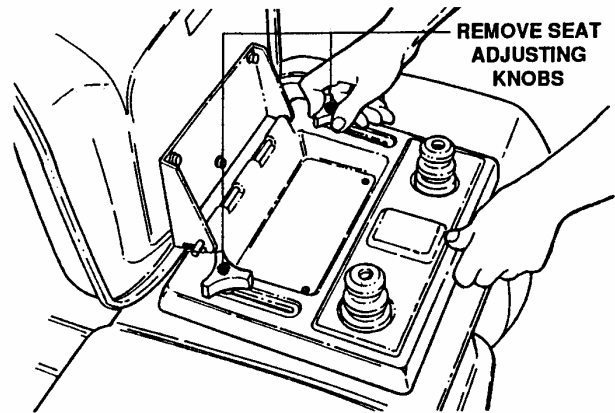

FIGURE 18

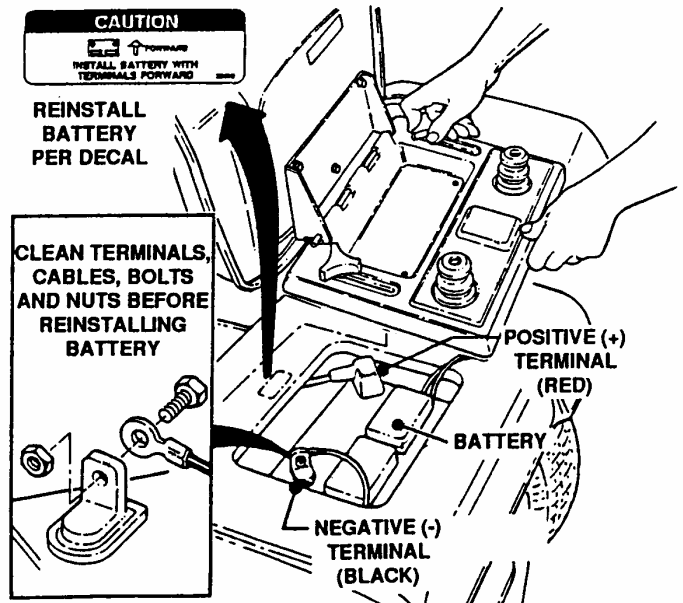

FIGURE 19

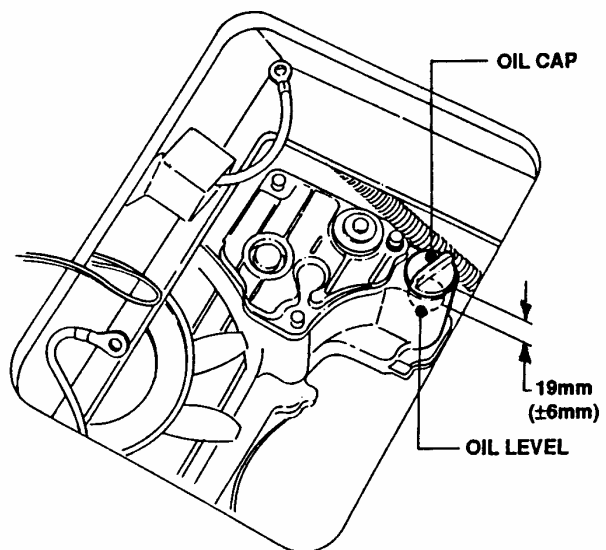

FIGURE 20



# MAINTENANCE INSTRUCTIONS

## CHANGING ENGINE OIL

### MODEL ELT125G33DB

This model is equipped with a 12 1/2 hp engine which is furnished with an extended oil drain. See Figure 21.

Raise tractor hood, disconnect spark plug wire and secure wire away from spark plug.

Put a brick or block of wood under tractor wheels on opposite side of oil drain. This aids in all oil draining from engine.

Loosen oil fill cap on engine.

Place a 2 liter capacity flat container beneath end of oil drain.

Remove oil plug.

Allow engine oil to drain completely.

After all oil has drained, replace oil plug and fill engine with new motor oil as specified in Engine Owner's Manual.

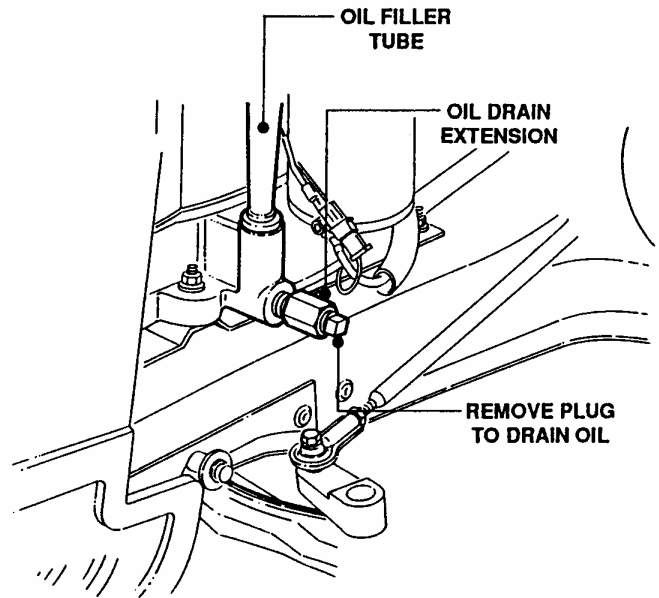

FIGURE 21

### MODEL ELT140H33DBV

This model is equipped with a 14hp engine which is furnished with a Fastex™ oil drain. See Figure 22.

Raise tractor hood, remove spark plug wire from spark plug and secure wire away from plug.

Put a brick or wooden block under the tractor wheels on opposite side of oil drain. This aids in all oil draining from engine.

Loosen oil fill cap on engine.

Rotate drain body counterclockwise and pull out to open drain.

Drain oil into a 2 liter container placed beneath end of oil drain.

After all oil has drained, push drain body "IN" and rotate clockwise to close.

Fill engine with new motor oil as specified in Engine Owner's Manual.

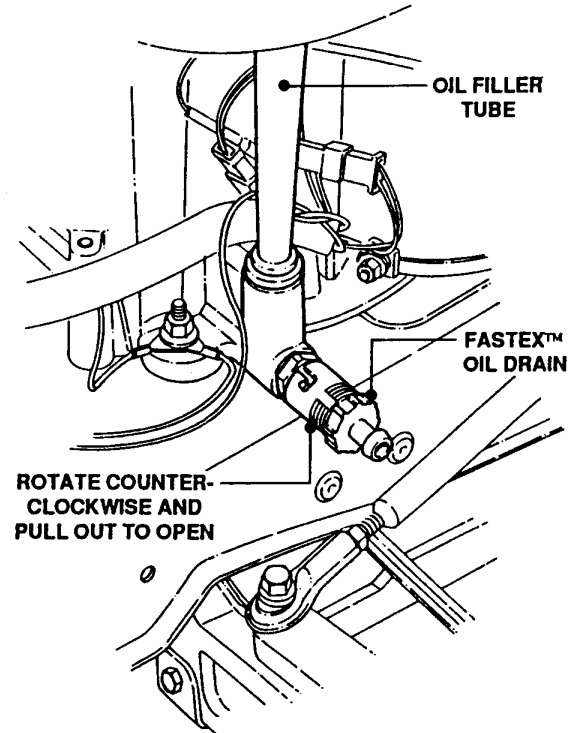

FIGURE 22

# MAINTENANCE INSTRUCTIONS

## LUBRICATION

The following lubrication points should be serviced after each 25 operating hours to insure optimum performance of the Lawn Tractor.

### FRONT WHEEL BEARINGS

Lubricate each front wheel bearing through the grease fitting on wheel hub. Using general purpose grease in a grease gun, add grease until grease purges from bearing. See Figure 23.

### AXLE SPINDLES

Lubricate each axle spindle with 1 shot of general purpose grease. See Figure 23.

### NOTE:

The R.H. spindle fitting faces forward and the L.H. spindle fitting faces to the rear.

### CLUTCH//BRAKE PIVOT

The clutch/brake pivot is located on the L.H. underside of the tractor and is lubricated with one shot of general purpose grease. See Figure 24.

### STEERING SECTOR GEAR

Lubricate with a light coat of 30 wt. motor oil. See Figure 25.

### STEERING SHAFT

Lubricate steering shaft wear points with a light coat of 30 wt. motor oil.

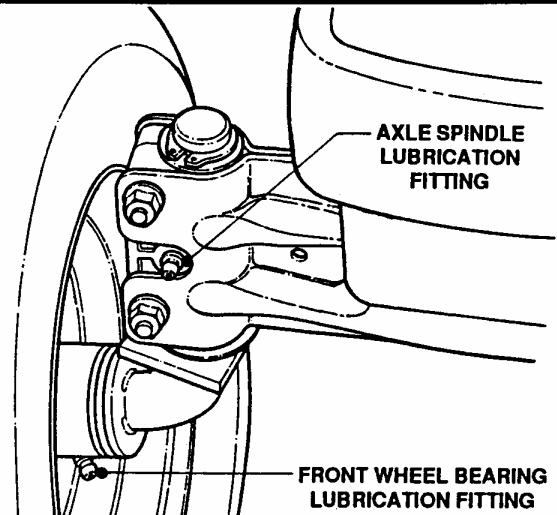

FIGURE 23

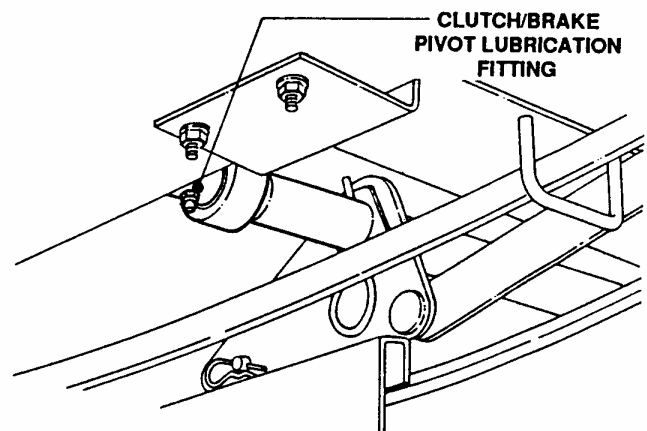

FIGURE 24

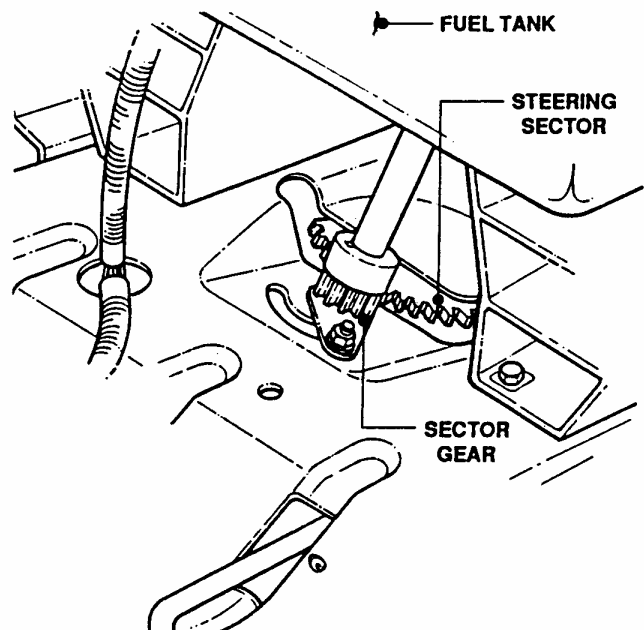

FIGURE 25

# MAINTENANCE INSTRUCTIONS

## LUBRICATION Continued

### STEERING DRAG LINK

Lubricate both ends of steering drag link with a small amount of 30 wt. motor oil from an oil can. See Figure 26.

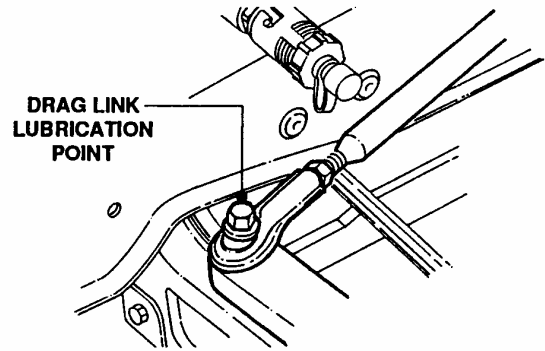

FIGURE 26

### STEERING TIE ROD

Using an oil can, filled with 30wt. motor oil, lubricate both ends of steering tie rod. See Figure 27.

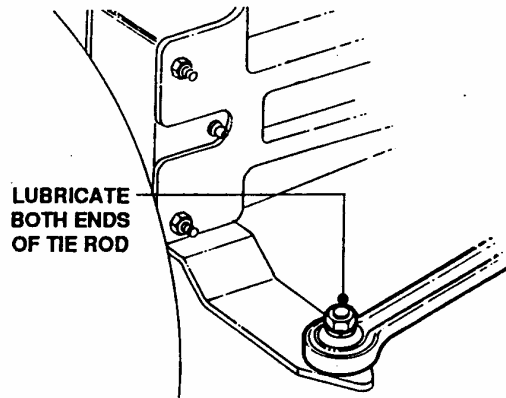

FIGURE 27

### BLADE ENGAGEMENT MECHANISM

Using 30 wt. motor oil, lubricate the blade engagement mechanism pivot points, which are located on the R.H. underside of tractor. See Figure 28.

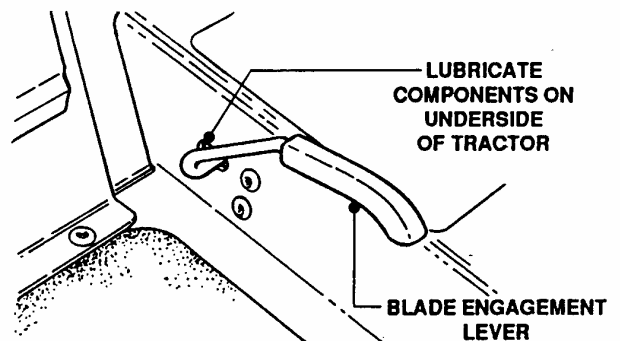

FIGURE 28

### PARK BRAKE LATCH

Using 30 wt. motor oil, lubricate the park brake latch mechanism pivot points, which are located on the L.H. underside of tractor. See Figure 29.

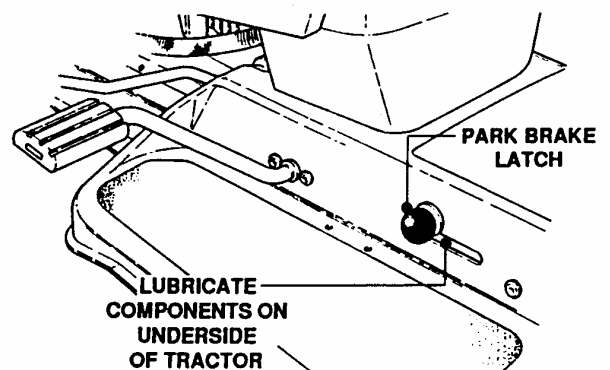

FIGURE 29

### DECK LIFT MECHANISM

Lubricate all wear and pivot points of the deck lift mechanism with a thin coat of 30 wt. motor oil.

# MAINTENANCE INSTRUCTIONS

## TRACTOR SERVICE

The components listed should be serviced on a regular basis to insure that they are in top working condition. Refer to **SERVICE SCHEDULE** on Page 15 for recommended service intervals.

### ENGINE AIR PRE-CLEANER

The engine air pre-cleaner should be removed and cleaned every 25 operating hours. See Figure 30. Refer to Engine Owner's Manual for specific cleaning instructions.

### ENGINE AIR CLEANER

The engine air cleaner element should be removed and replaced every 25 operating hours. See Figure 30. Contact engine manufacturer's dealer for correct replacement element.

### SPARK PLUG

Remove and replace engine spark plug after 100 operating hours. Refer to Engine Owner's Manual for correct replacement plug and gap specifications.

### FUEL FILTER

The engine fuel filter should be replaced every 100 operating hours. Remove the fuel filter as follows:

#### NOTE:

It may be necessary to drain the fuel tank before removing fuel filter to prevent excessive spillage of gasoline.

Raise tractor hood.

Remove spark plug wire(s) and secure away from plug(s).

Locate fuel filter. Remove hose clamps and fuel hoses from both sides of fuel filter. See Figure 31.

Install new fuel filter part number 1-4359. See Figure 32.

Fill fuel tank with fresh gasoline. Refer to Engine Owner's Manual for fuel specifications.

Reconnect spark plug wire(s).

Lower tractor hood.

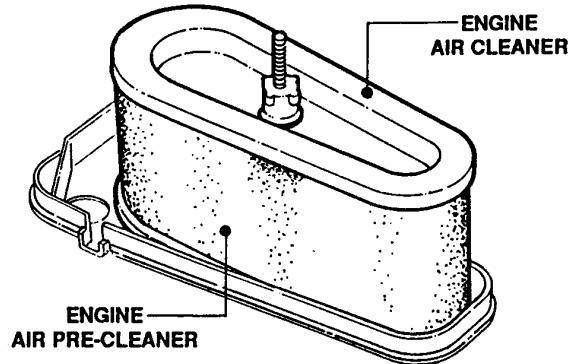

FIGURE 30

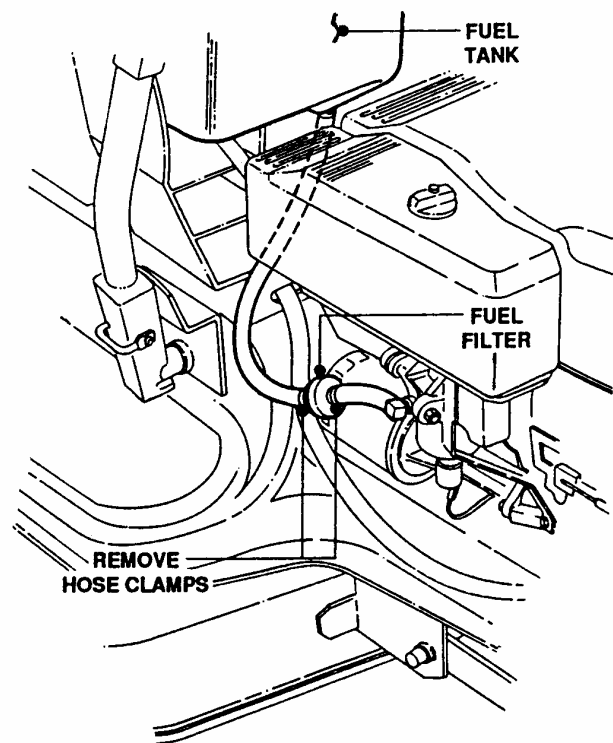

FIGURE 31

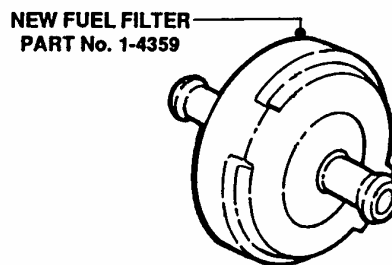

FIGURE 32

# MAINTENANCE INSTRUCTIONS

## TRACTOR SERVICE

### ENGINE COOLING SYSTEM

The engine cooling system consists of an engine shroud and engine fins. These should be kept clean and free of debris as needed or clean at least every 100 operating hours.

## BATTERY SERVICE

The battery should be serviced every 25 hours of operation.

Raise operator's seat.

Remove the two adjusting knobs.

Remove seat assembly and move forward. Use care not to disconnect wires from seat switch. See Figure 33.

Remove negative (-) cable first.

Remove positive (+) cable.

REMOVE ADJUSTING  
KNOBS AND MOVE  
SEAT FORWARD

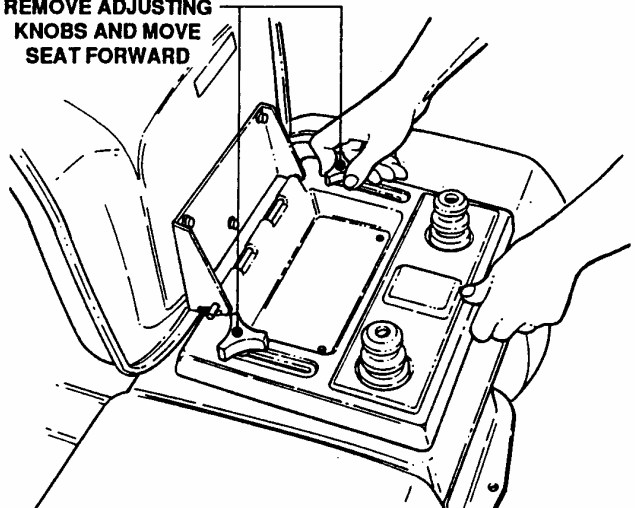

FIGURE 33

### CHECKING BATTERY ELECTROLYTE

Carefully remove battery cell covers.

Visually check electrolyte level in each cell. Level should be approximately 5mm above cell plates, up to fill rings.

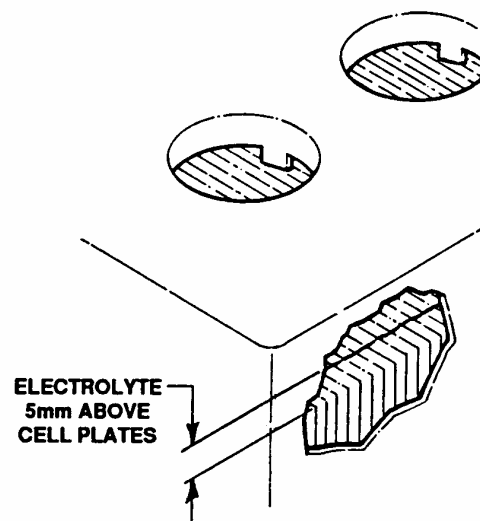

FIGURE 34

# MAINTENANCE INSTRUCTIONS

## BATTERY SERVICE

Using distilled water, fill cells as needed to 5mm above cell plates.

Replace cell covers.

Charge battery if required.

Install positive(+) cable first.

Install negative(-) cable last.

Install seat assembly over battery and secure in position with adjusting knobs. Leave knobs loose.

Lower operator's seat and adjust to desired position.

Raise seat and tighten adjusting knobs.

## BATTERY CHARGING

The engine is equipped with a flywheel alternator to charge the battery. If the tractor is not run regularly, connect the battery to a charger monthly to maintain the specific gravity at 1.250 or higher. If this reading falls below 1.175, the battery liquid may freeze when temperatures drop to around -32 degrees C. To charge, connect per instructions furnished with charger. If time allows, slow charge at 1 amp for ten hours, or as an alternate, fast charge at 3 amps for four hours. Observe all precautions while charging.

## BELT SERVICE

### TRACTION DRIVE BELT

Check the traction drive belt for damage and wear after 25 operating hours. The traction drive belt is located on the underside of the tractor and spans from the engine pulley's top groove to the transmission pulley. See Figure 35.

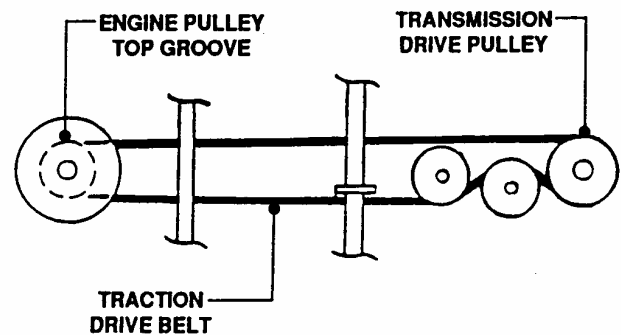

FIGURE 35

# MAINTENANCE INSTRUCTIONS

## BELT SERVICE Continued

Should the traction drive belt show signs of excessive wear or damage, replace.

### MOWER DECK REMOVAL

Place tractor on a firm, level surface such as a driveway or garage floor and engage park brake.

Turn engine "OFF".

Raise hood and remove spark plug wire from spark plug.

Secure spark plug wire away from spark plug. See Figure 36.

Lower deck to lowest setting.

Disconnect deck lift rod from front lift arm. See Figure 37.

Remove hair pins from front deck hanger rod. See Figure 38.

Turn wheels to the left.

Hold front of deck "UP" and slide front deck hanger rod to the right and out.

Lower front of deck to ground.

Remove hair pin and flat washer from rear deck hanger bracket on both sides of tractor. See Figure 39.

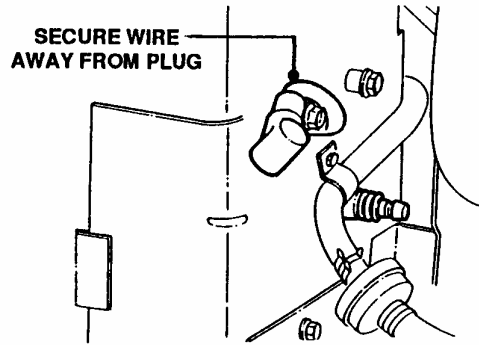

FIGURE 36

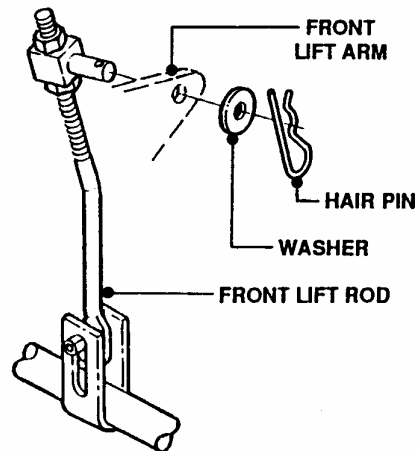

FIGURE 37

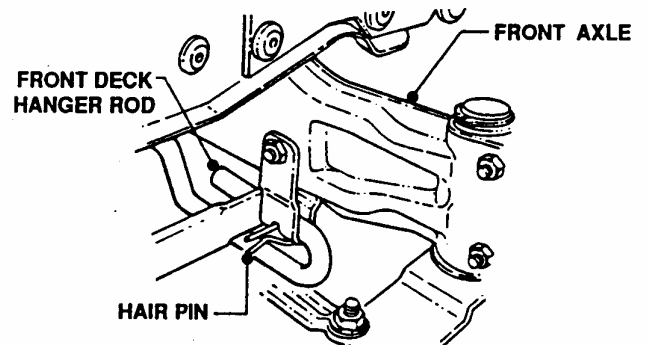

FIGURE 38

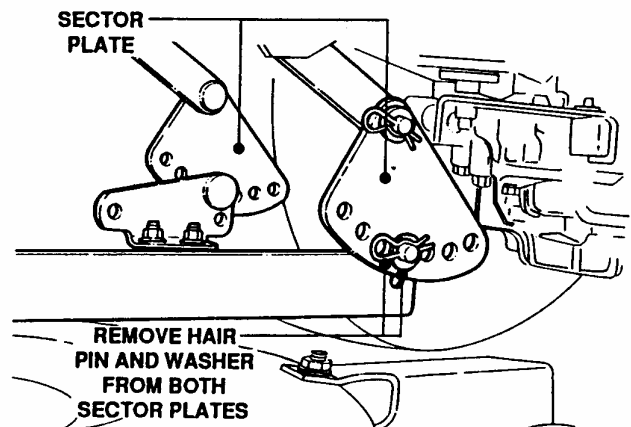

FIGURE 39

# MAINTENANCE INSTRUCTIONS

## BELT SERVICE Continued

Make note of hole used in sector plate.

Slide sector plates off of rear deck hanger brackets.

Slide deck forward.

Remove deck drive belt from engine pulley bottom groove. See Figure 40.

Slide deck back and disconnect spring from tension idler. Refer to Figure 56.

Pull deck from under tractor from R.H. side.

### TRACTION DRIVE BELT REMOVAL/REPLACEMENT

Remove two belt guide mounting bolts from each side of tractor frame. See Figure 41.

Slide belt guide assembly to the rear and remove.

Disconnect traction belt idler pulley spring from tractor frame. See Figure 42.

Loosen mounting nuts on traction drive belt tension and stationary idlers just enough to allow belt to clear belt guides. See Figure 43.

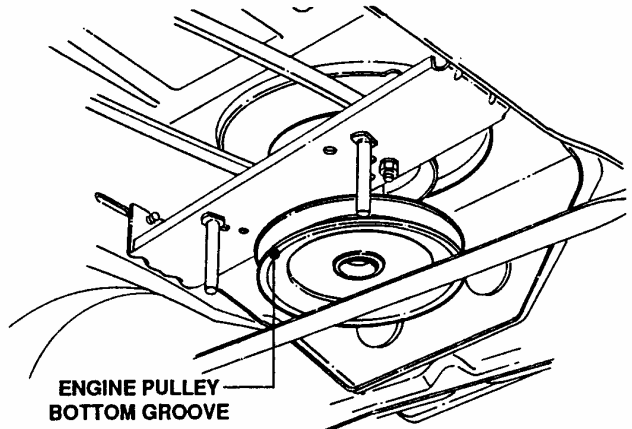

FIGURE 40

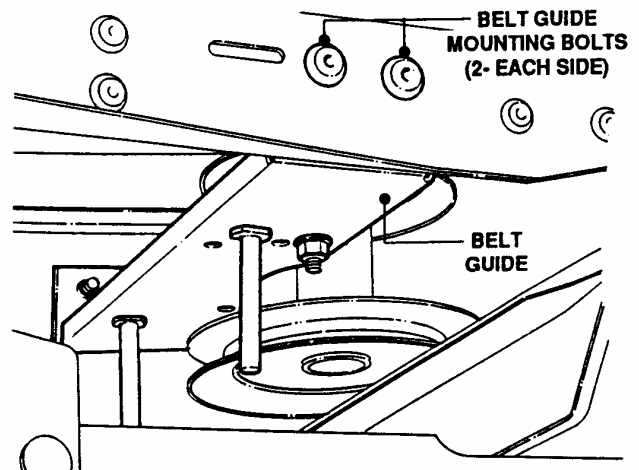

FIGURE 41

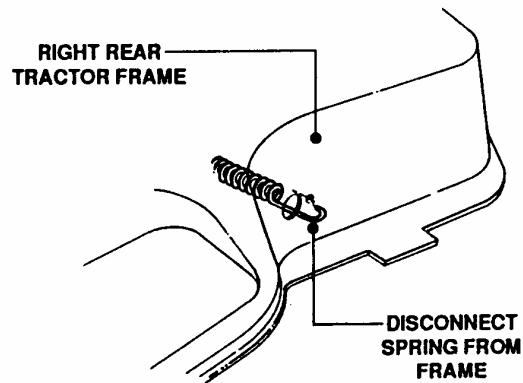

FIGURE 42

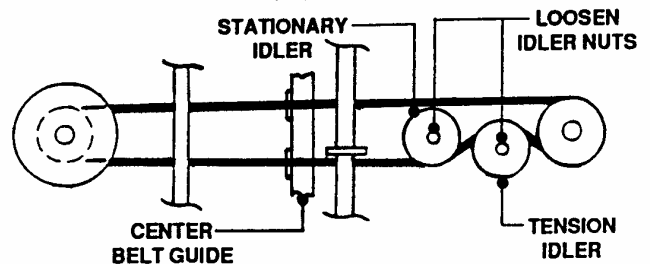

FIGURE 43



# MAINTENANCE INSTRUCTIONS

## BELT SERVICE Continued

Remove traction drive belt from engine pulley top groove.  
See Figure 44.

Remove belt from center belt guide.

Pull belt until it can be removed from transmission pulley.

### TRACTION DRIVE BELT REPLACEMENT

Place new traction drive belt over transmission pulley and span to engine pulley.

Place belt into top groove of engine pulley.

Route belt through stationary and tension idlers. See Figure 45.

#### NOTE:

When installing a new belt, make certain the stationary idler is mounted in the hole closest to the L.H. side of the tractor and the belt guide tab is seated in its orientation hole. See Figure 45.

Make certain belt is within belt guides of idlers.

Adjust idler belt guides to obtain 1.5mm clearance between belt and guide. See Figure 45.

Attach tension idler spring to tractor frame. See Figure 46.

Reinstall mower deck in reverse order of removal.

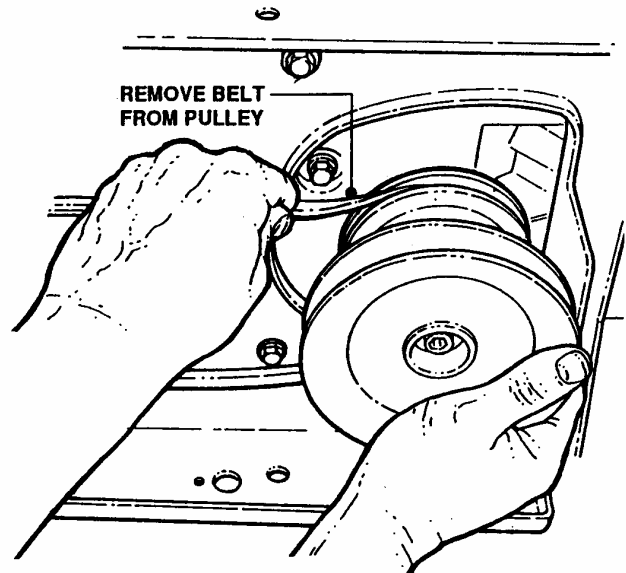

FIGURE 44

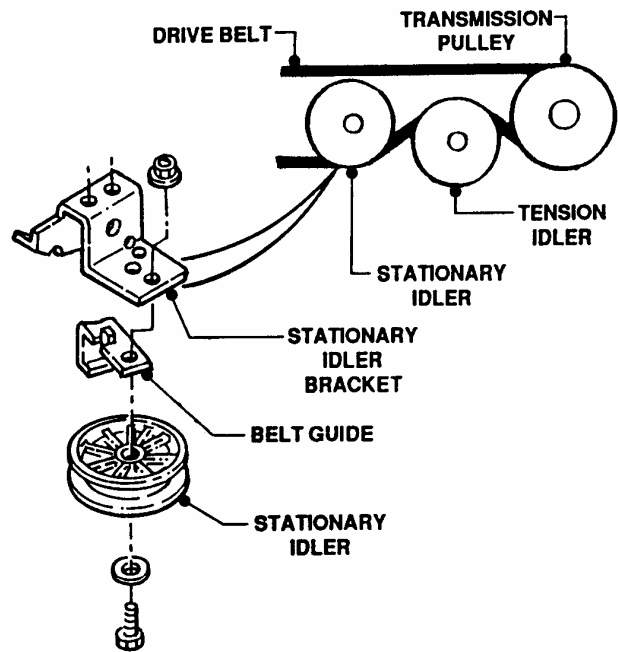

FIGURE 45

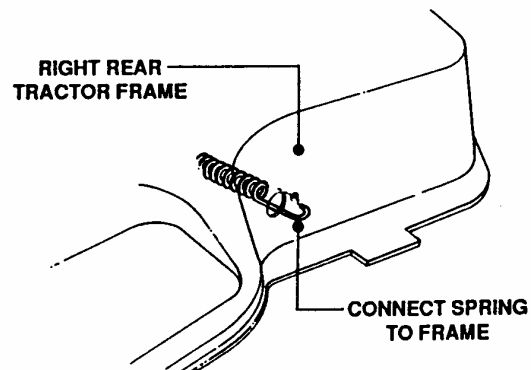

FIGURE 46

# MAINTENANCE INSTRUCTIONS

## BELT SERVICE Continued

### 84CM DECK BELT REMOVAL AND REPLACEMENT

Inspect deck drive belt for excessive wear and damage after every 25 operating hours. Replacement procedures are as follows:

Place tractor on a firm, level surface.

Turn engine "OFF" .

Raise hood, remove spark plug wire from spark plug and secure wire away from spark plug.

Remove mower deck.

Remove deck belt idler pulley. See Figure 47.

Remove spindle pulley cover. See Figure 47.

Remove old belt.

Replace with new belt, part number 2-6546.

Adjust idler pulley belt guide if necessary to obtain 1.5mm clearance between belt and belt guide. See Figure 48.

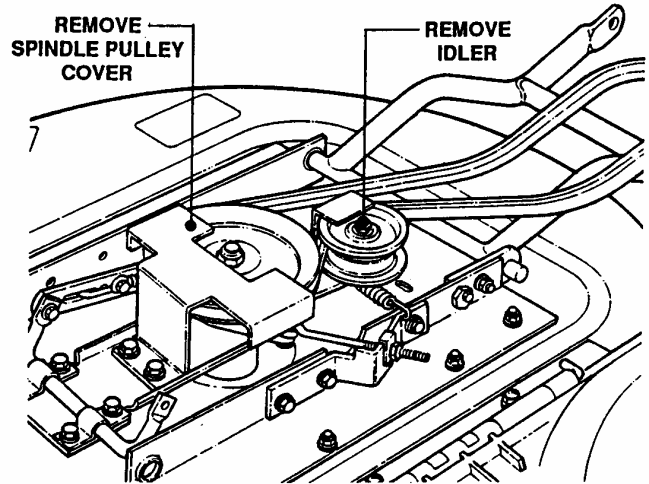

FIGURE 47

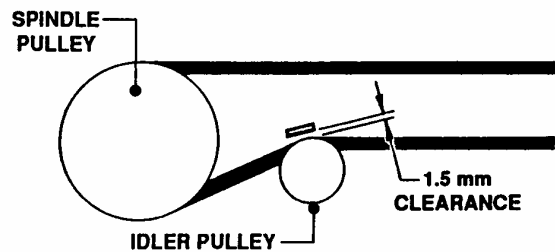

FIGURE 48

## STANDARD MOWER BLADE SERVICE

### STANDARD BLADE WEAR LIMITS

All mower blades should be checked for excessive wear and damage before each use. See Figure 49.

### 84CM MOWER BLADE REMOVAL/REPLACEMENT

Move tractor to a firm, level surface.

Turn engine "OFF".

Raise hood, remove spark plug wire from spark plug and secure wire away from spark plug.

Remove deck from tractor.

Carefully position deck on its left side to access blade.

Remove blade mounting bolts, nuts and washers. See Figure 50.

Install new blade, part number 1-9523, onto blade bar. Torque mounting bolts and nuts to 1313 Nm.

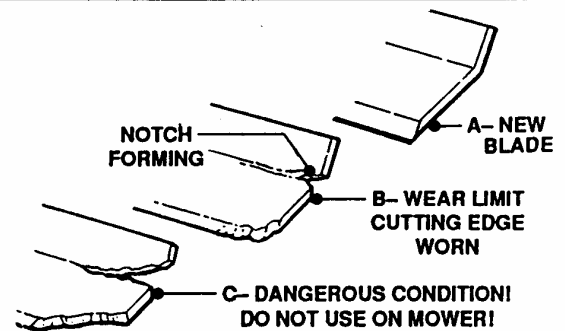

FIGURE 49

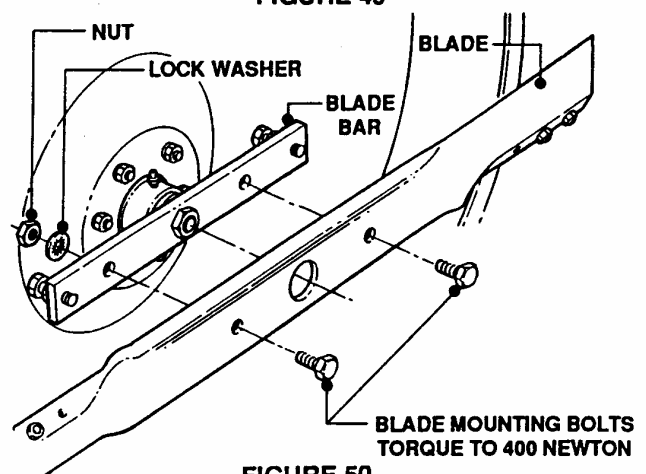

FIGURE 50

# MAINTENANCE INSTRUCTIONS

## STANDARD MOWER BLADE SERVICE Continued

### SHARPENING STANDARD BLADE(S)

Blades should be kept sharp at all times. When the blade(s) are dull, cut grass will be ragged and lawn will usually turn brown. Sharpen standard blades as follows:

Move tractor to a firm, level surface.

Turn engine "OFF".

Raise hood, remove spark plug wire from spark plug and secure wire away from plug.

Remove mowing deck from tractor.

Remove mower blade(s)

Inspect for excessive wear or damage.

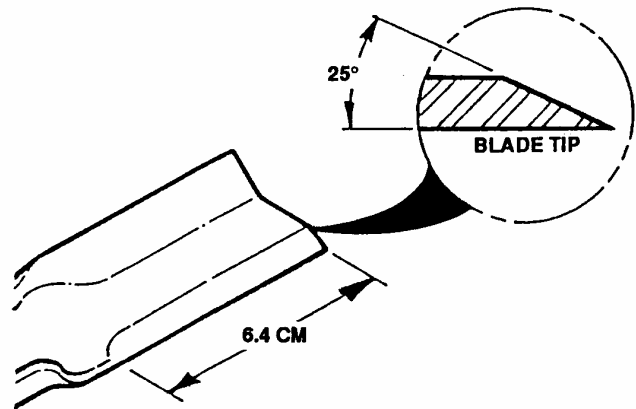



FIGURE 51

	<b>WARNING</b>	
<p><i>Never use a blade that shows signs of excessive wear or damage. Refer to Figure 52 for standard blade wear limits.</i></p>		

Sharpen standard mower blade(s) at 25° angle. See Figure 51.

## NINJA™ MOWER BLADE SERVICE

### NINJA™ BLADE WEAR LIMITS

The Ninja™ recycling blade requires more frequent service intervals than standard blades. Check the Ninja™ recycling blade for excessive wear or damage after every use. See Figure 52.

### NINJA™ BLADE SHARPENING

The Ninja™ recycling blade requires more frequent sharpening than standard blades due to its recycling method.

Remove the Ninja™ blade by following procedures for standard blade removal.

Inspect the Ninja™ blade for excessive wear or damage. See Figure 52 for Ninja™ blade wear limits.

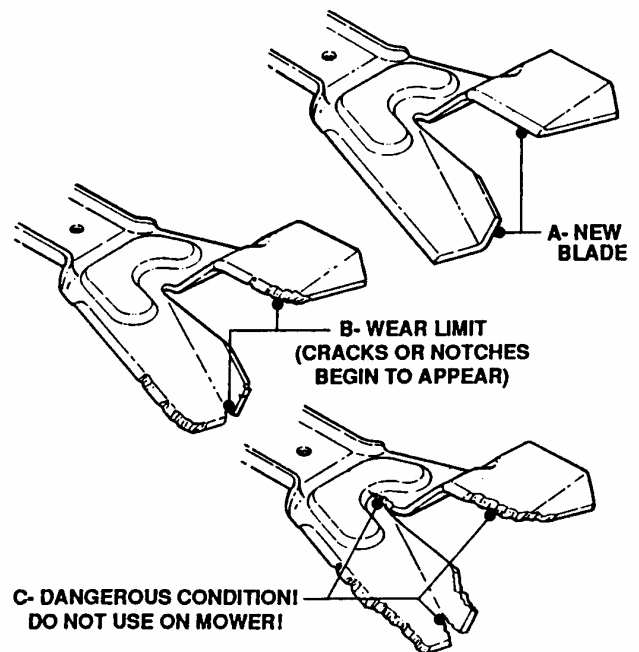

FIGURE 52

# MAINTENANCE INSTRUCTIONS

## NINJA™ MOWER BLADE SERVICE Continued



### WARNING



*Never use a blade that shows signs of excessive wear or damage. Refer to Figure 52 for Ninja™ blade wear limits.*

Sharpen all cutting edges of the Ninja™ recycling blade at 27° for optimum performance. See Figure 53.

Reinstall sharpened Ninja™ blade in reverse order of removal.

Torque mounting bolts or nuts to 1313 Nm.

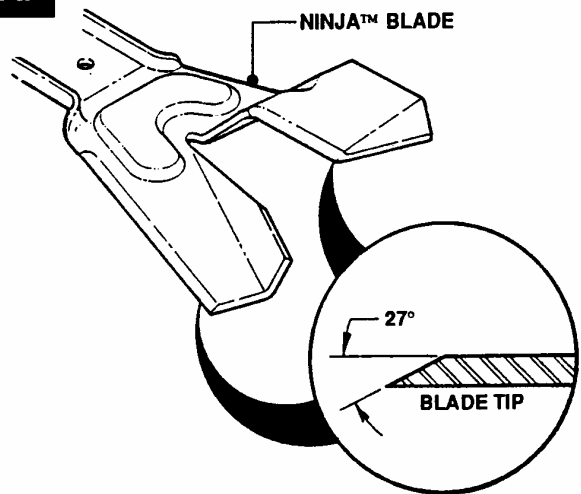

FIGURE 53

## TRACTION DRIVE BELT ADJUSTMENT

Should a gradual loss of traction be noticed, it may be necessary to adjust the traction drive belt tension. Adjust as follows:

Move tractor to a firm, level surface.

Turn engine "OFF".

Raise hood, remove spark plug wire from spark plug and secure wire away from plug.

Remove mowing deck.

Remove the traction drive belt stationary idler mounting bolt. See Figure 54.

Move the stationary idler one hole towards left side of tractor for more belt tension. Make sure the belt guide tab lines up with hole in bracket.

### NOTE:

Note the orientation of belt guide and make certain it remains in the same orientation after moving idler.

### NOTE:

Should less tension be required move stationary idler towards right side of tractor. See Figure 54.

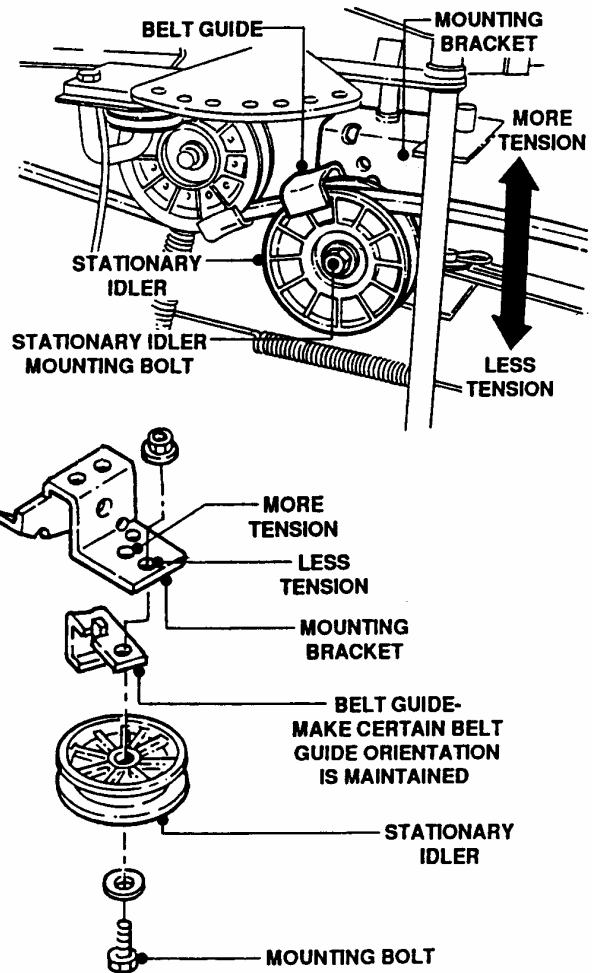

FIGURE 54

# MAINTENANCE INSTRUCTIONS

## TRACTION DRIVE BELT ADJUSTMENT Continued

Secure stationary idler with mounting bolt.

Place spark plug wire onto spark plug.

Set park brake.

Start Engine.

Visually inspect traction drive belt for movement.

When properly adjusted, the traction drive belt should not have any movement or rotation with the engine running and park brake engaged.

Should movement be present, readjust traction drive belt to release belt tension as described in previous instructions.

## BLADE BELT ADJUSTMENT

Move tractor to a firm, level surface.



Turn engine "OFF".

Raise hood, remove spark plug wire from spark plug and secure wire away from plug.

Move blade engagement lever down to "OFF". See Figure 55.

Lower deck to lowest cutting position

Check front to rear level.

	<b>CAUTION</b>	
<i>If deck front to rear level is not correct, this could cause blade belt problems.</i>		

### 84CM DECK

Measure length of blade cable extension spring. See Figure 56.

Move blade engagement lever to "ON".

Measure blade cable extension spring. Spring should extend 25.5mm ( $\pm 3$ mm) for proper belt tension. See Figure 56.

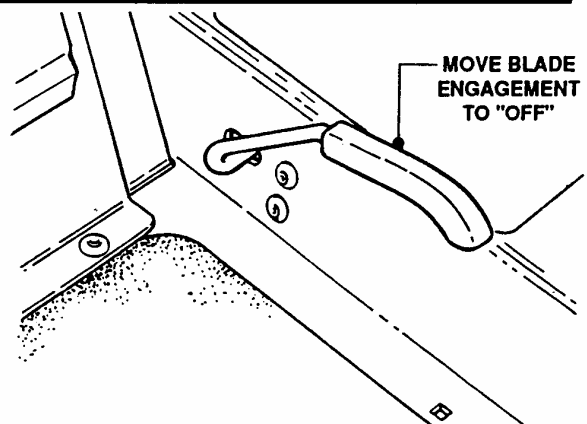

FIGURE 55

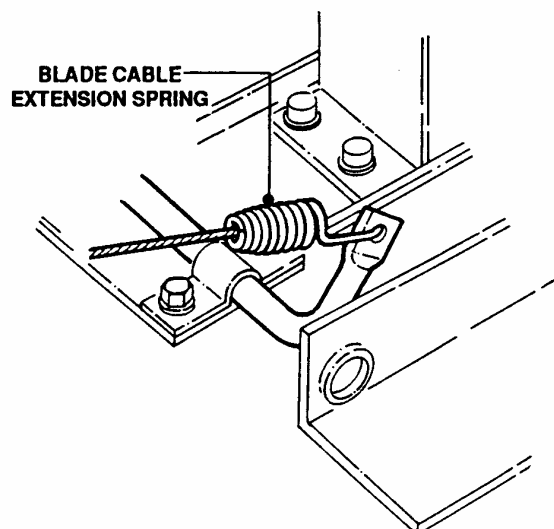

FIGURE 56

# MAINTENANCE INSTRUCTIONS

## BLADE BELT ADJUSTMENT Continued

To adjust tension, remove extension rod mounting bolt and nut. See Figure 57.

Move extension rod to next hole towards rear of deck and secure with mounting bolt and nut.

Measure extension spring with blade engagement lever in the "ON" and "OFF" positions. See Figure 56. Continue adjustment until tension is correct.

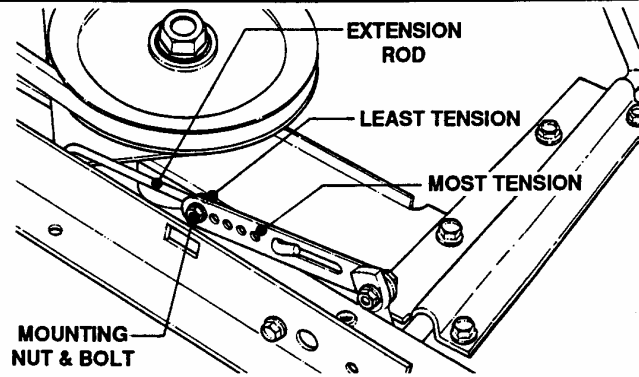

FIGURE 57

## DECK LEVEL ADJUSTMENT

### NOTE:

Before adjusting deck, bring tire pressure to proper psi. Front 12 psi, Rear 10 psi.

### SIDE TO SIDE LEVEL

Move tractor to a firm, level surface.

Turn engine "OFF".

Raise hood, remove spark plug wire from spark plug and secure wire away from plug.

Move blade engagement lever to "OFF".

Place a piece of angle iron under center rear of deck.

Remove hair pins and washers securing rear of deck to sector plates. See Figure 58.

Slide sector off of pins and carefully lower deck onto angle iron.

Rotate blade(s) until blade tips are at each side of deck.

Measure distance from blade tip to floor on each side of deck.

Blade tips should be within 3mm of each other for the deck to be considered level. See Figure 59.

If measurement differs more than 3mm, adjust as follows:

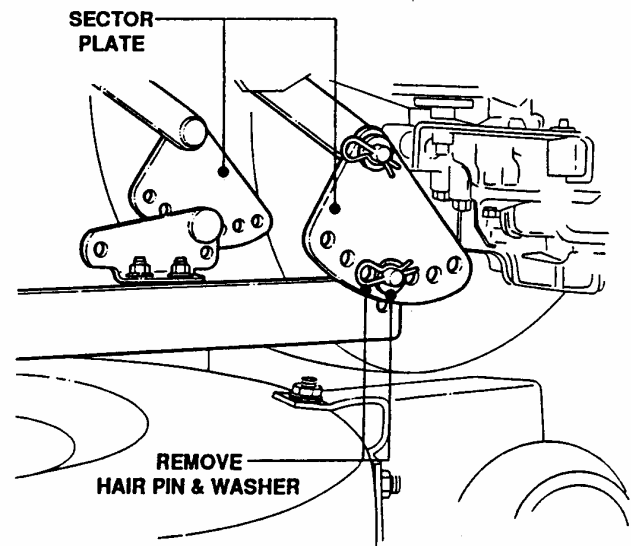

FIGURE 58

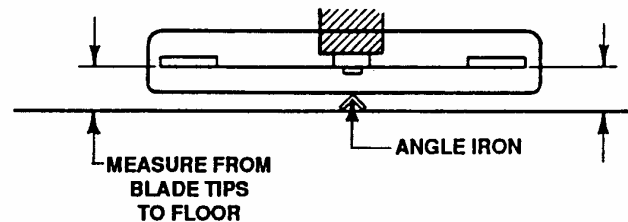

FIGURE 59

# MAINTENANCE INSTRUCTIONS

## DECK LEVEL ADJUSTMENT Continued

Loosen front lift arm pivot bolt on front of right side rail. See Figure 60.

Loosen eccentric shoulder bolt. See Figure 60.

Turn eccentric "UP" or "DOWN" as required to level deck. See Figure 60.

Tighten eccentric shoulder bolt.

Tighten pivot bolt.

Place sector plates back onto rear lift arms and secure with washers and hairpins.

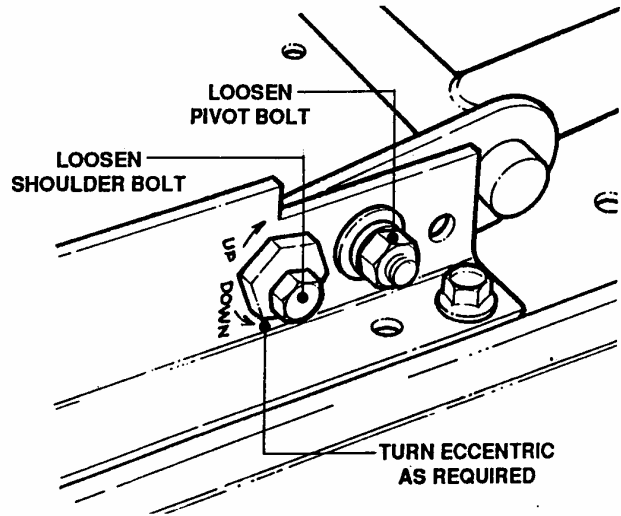

FIGURE 60

### FRONT TO REAR LEVEL- SECTOR PLATES

Remove hair pins and washers securing sector plates to rear lift arms. See Figure 61.

Move sector plate as required to raise or lower deck.

### NOTE:

The 84cm deck should be set so that the rear of the deck is 6mm lower than the front. See Figure 62.

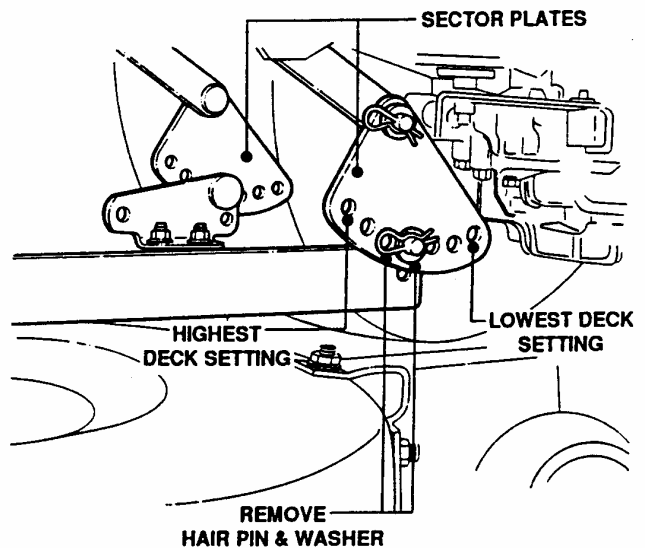

FIGURE 61

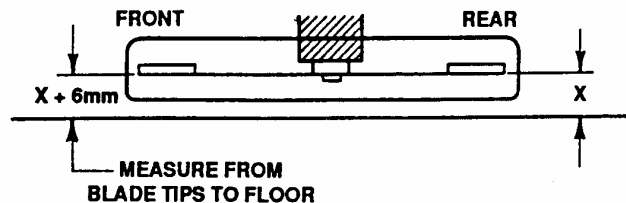

FIGURE 62

# MAINTENANCE INSTRUCTIONS

## DECK LEVEL ADJUSTMENT Continued

### **FRONT TO REAR LEVEL– FRONT LIFT ROD**

If the sector plates are in their lowest setting and proper level cannot be obtained, adjust the front lift rod as follows:

Move deck lift lever to #5 position.

Place a 50mm X 100mm wooden block on edge under front center of deck.

Place a 76mm X 76mm wooden block under rear center of deck.

Remove hair pins and washers securing sector plates. Lower rear of deck onto 76mm X 76mm block. See Figure 61.

Remove hair pin and washer securing front lift rod to front lift arm. See Figure 63.

Remove front lift rod and carefully rest front of deck onto 50mm X 100mm block.

Loosen jam nut on front lift rod. See Figure 63.

Turn front lift rod hanger block until it can be reinstalled into front lift arm without lifting deck. See Figure 63.

Secure lift rod to lift arm with washer and hair pin.

Place sector plates onto rear hanger brackets and secure with washers and hair pins.

Raise deck and remove wooden blocks.

Repeat steps for front to rear level adjustment. Refer to *FRONT TO REAR LEVEL– SECTOR PLATES*.

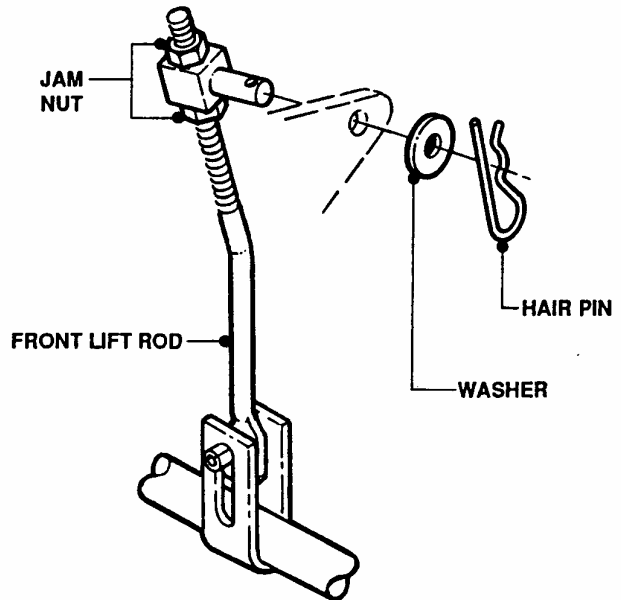

FIGURE 63



# MAINTENANCE INSTRUCTIONS

## STEERING ADJUSTMENT

### STEERING SECTOR

Should excessive "PLAY" be present in the steering, adjust as follows:

Turn Engine "OFF" and raise tractor hood.

Remove spark plug wire from spark plug and secure wire away from plug.

From left side of tractor, locate the steering sector below fuel tank. See Figure 64.

Loosen eccentric mounting nut.

Rotate eccentric clockwise until steering "PLAY" is reduced. See Figure 64.

Tighten eccentric mounting nut.

Replace spark plug wire onto spark plug and lower hood.

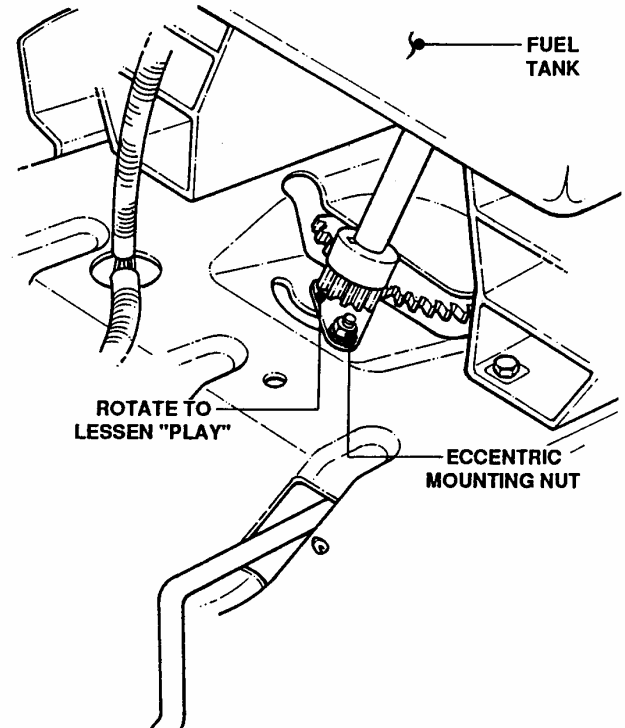

FIGURE 64

## SHIFTER ADJUSTMENT

If movement of tractor does not correspond with the selected speed on shift quadrant, adjust the speed control lever as follows:

With engine running, drive tractor and move shift lever to locate neutral.

Turn engine "OFF".

Raise hood, remove spark plug wire from spark plug and secure wire away from plug.

Locate speed control lever mount behind right rear tire. See Figure 65.

Loosen mounting nuts.

Move the speed control lever until it is in direct relation to the neutral ( N ) position on quadrant. See Figure 66.

Tighten mounting nuts.

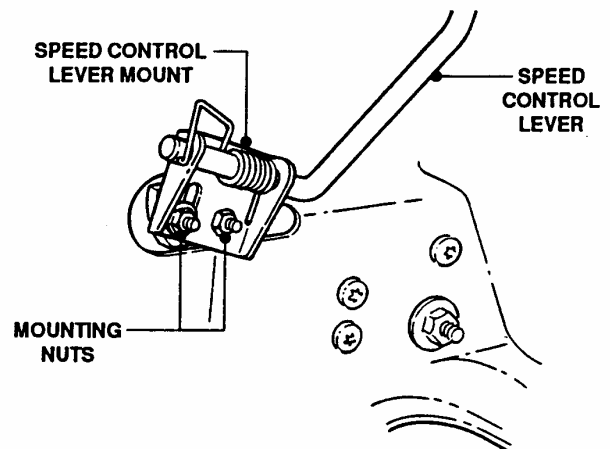

FIGURE 65

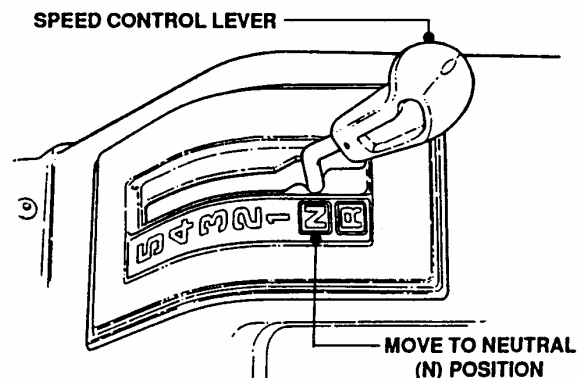

FIGURE 66

# MAINTENANCE INSTRUCTIONS

## BRAKE ADJUSTMENT

### **MODEL ELT140H33DBV**

To be properly adjusted, the brake should stop the tractor within 1.6 meters from top speed when the clutch/brake pedal is fully depressed.

Adjust brake when necessary as follows:

Turn engine "OFF".

Raise hood, remove spark plug wire from spark plug and secure wire away from plug.

Locate brake adjustment on right side of tractor in front of and behind right rear wheel. See Figure 67.

Turn nut clockwise to increase braking action or, counterclockwise to decrease braking action. See Figure 67.

Replace spark plug wire, start engine and test brake.

Continue adjustment as described above until proper adjustment is achieved.

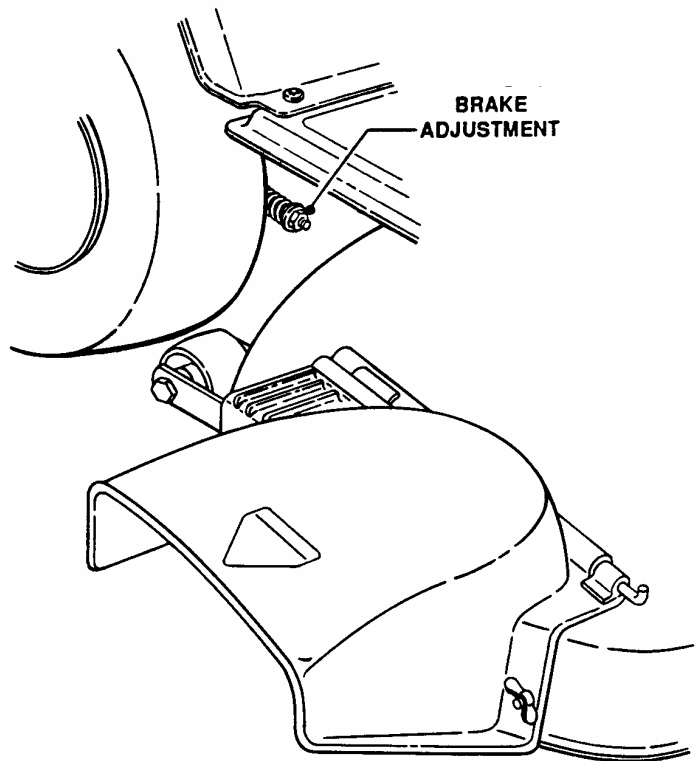

FIGURE 67

### **MODEL ELT125G33DB**

To be properly adjusted, the brake should stop the tractor within 1.6 meters from top speed when the clutch/brake pedal is fully depressed.

Adjust brake when necessary as follows:

Turn engine "OFF".

Raise hood, remove spark plug wire from spark plug and secure wire away from plug.

Locate brake adjustment on right side of tractor in back of and behind right rear wheel. See Figure 68.

Turn nut clockwise to increase braking action or, counterclockwise to decrease braking action. See Figure 68.

Replace spark plug wire, start engine and test brake.

Continue adjustment as described above until proper adjustment is achieved.

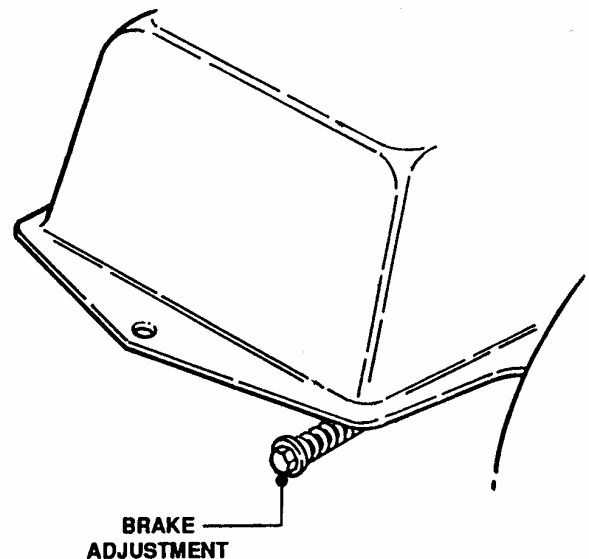

FIGURE 68

# ELECTRICAL

## HARNESS ROUTING

Figure 69 illustrates typical harness routing on all the Series D Lawn Tractors. Use this when locating various electrical components.

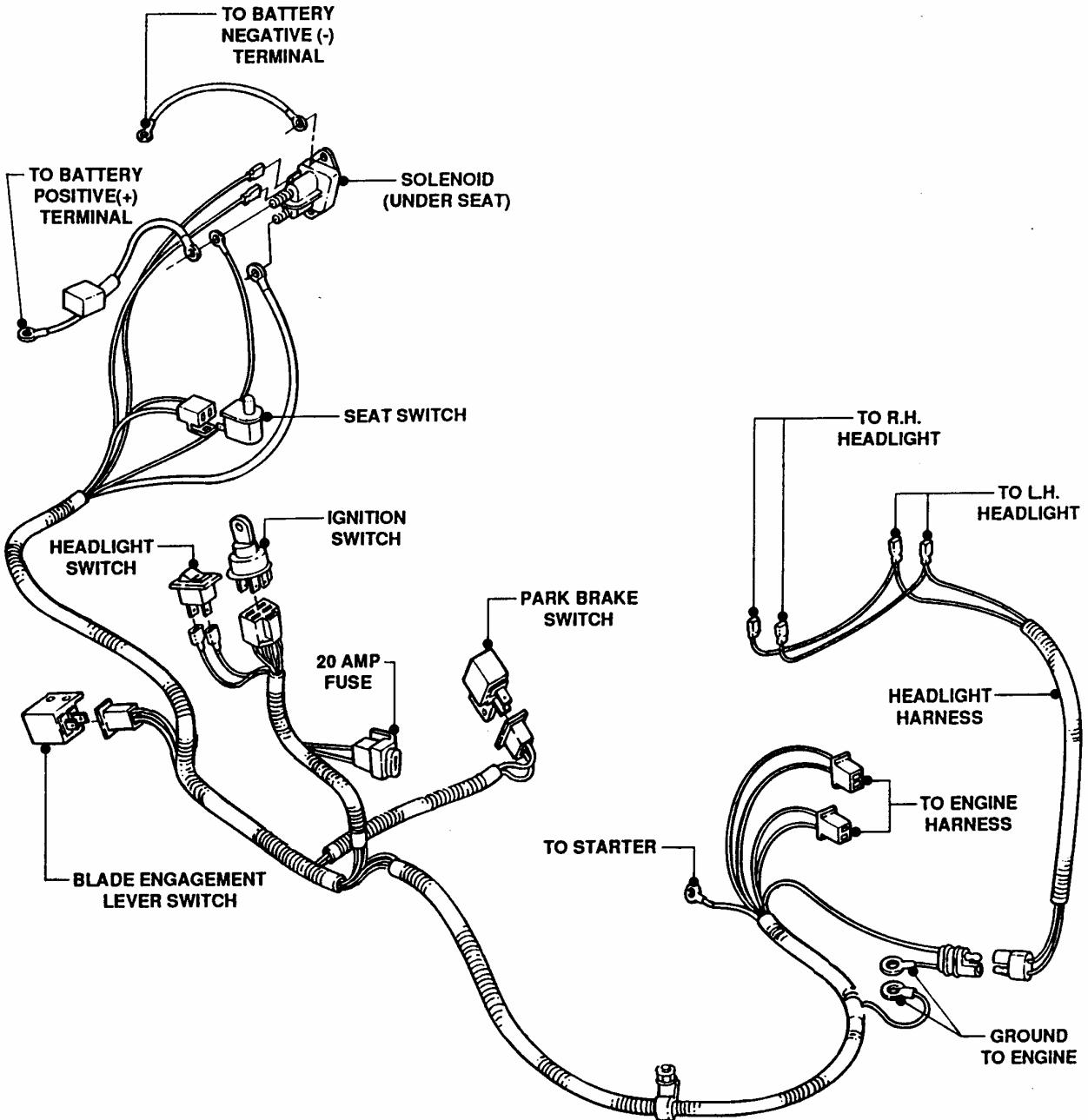

FIGURE 69

# ELECTRICAL

## SCHEMATICS

The schematics below, Figure 70 & Figure 71 represent models with and without headlights.

### BRIGGS & STRATTON WITHOUT LIGHTS

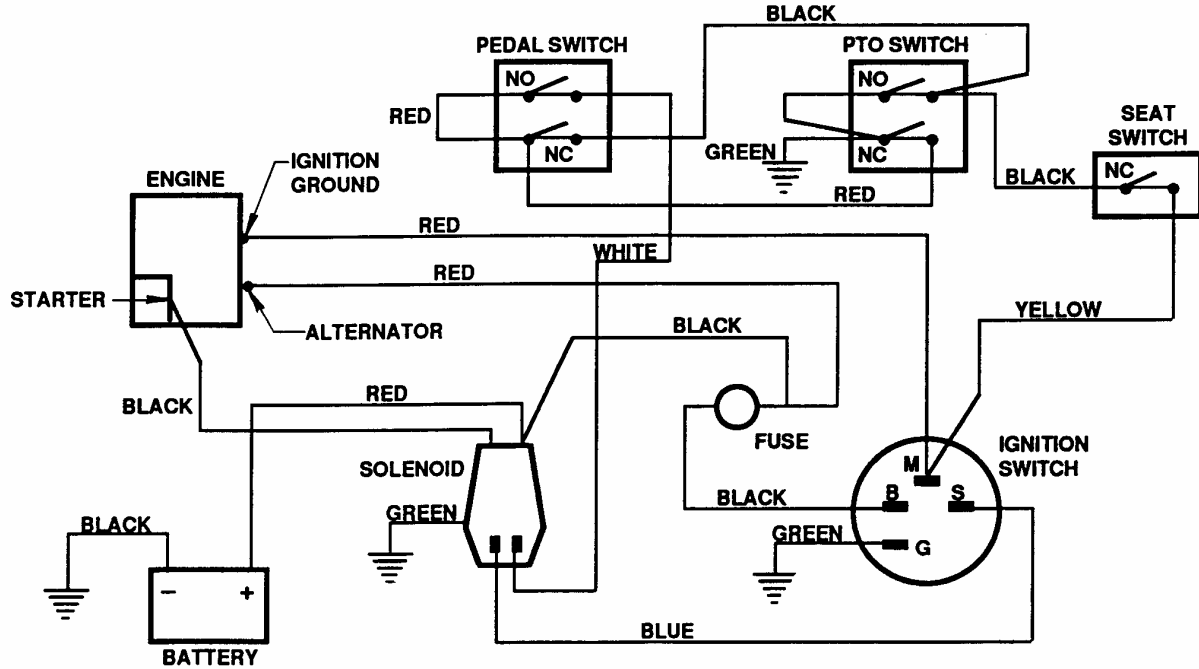

FIGURE 70

### BRIGGS & STRATTON WITH LIGHTS

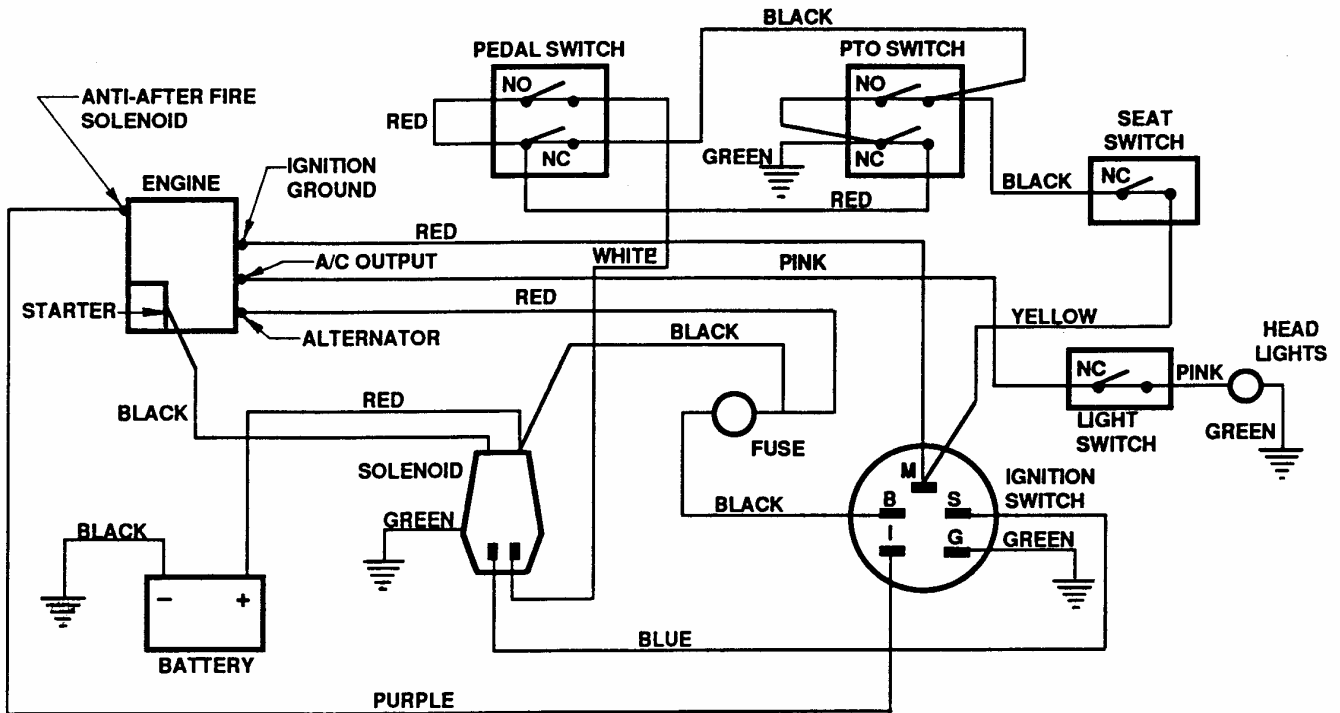

FIGURE 71

# **SNAPPER®**

## **3 YEAR LIMITED WARRANTY**

For three (3) years from purchase date for the original purchaser's residential, non-commercial use, **SNAPPER**, through any authorized **SNAPPER** dealer will replace, free of charge (except for taxes where applicable), any part or parts found upon examination by the factory at McDonough, Georgia, to be defective in material or workmanship or both.

For ninety (90) days from purchase date for the original purchaser's commercial, rental, or other non-residential use, **SNAPPER**, through any authorized **SNAPPER** dealer will replace, free of charge, any part or parts found upon examination by the factory at McDonough, Georgia, to be defective in material or workmanship or both.

All transportation costs incurred by the purchaser in submitting material to an authorized **SNAPPER** dealer for replacement under this warranty must be paid by the purchaser.

This warranty does not apply to engines and their components, and batteries, as these items are warranted separately. This warranty does not apply to parts that have been damaged by accident, alteration, abuse, improper lubrication, normal wear, or other cause beyond the control of **SNAPPER**. This warranty does not cover any machine or component part that has been altered or modified changing safety, performance, or durability.

Batteries have a one (1) year prorated warranty period with free replacement if required during the first ninety (90) days from the original purchase date. **SNAPPER** will not be responsible for any installation cost incurred. The battery warranty only covers original equipment batteries and does not cover damage to the battery or machine caused by neglect or abuse, destruction by fire, explosion, freezing, overcharging, improper maintenance, or use of improper electrolyte.

There is no other express warranty.

### **DISCLAIMER OF WARRANTY**

Implied warranties, including those of merchantability and fitness for a particular purpose, are limited to three (3) years from purchase date for the original purchaser's residential or other non-commercial use, and ninety (90) days from purchase for the original purchaser's commercial, rental or other non-residential use, and to the extent permitted by law, any and all implied warranties are excluded. This is the exclusive remedy. Liabilities for consequential damages, under any and all warranties are excluded.

Some states do not allow limitations on how long an implied warranty lasts, or do not allow the exclusion or limitation of incidental or consequential damages, so the above limitation or exclusion may not apply to you.

This warranty gives you specific legal rights, and you may also have other rights which vary from state to state.

**WARNING: THE USE OF REPLACEMENT PARTS OTHER THAN GENUINE SNAPPER PARTS MAY IMPAIR THE SAFETY OF SNAPPER PRODUCTS AND WILL VOID ANY LIABILITY AND WARRANTY BY SNAPPER ASSOCIATED WITH THE USE OF SUCH PARTS.**

**IMPORTANT:** Please fill out the attached **SNAPPER** Product Registration Card immediately and mail to:  
**Snapper's Product Registration Center, P.O. Box 1379, McDonough, Georgia 30253**

*Safety Instructions & Operator's Manual for*

**SNAPPER®**

**EUROPEAN  
LAWN TRACTOR  
HYDROSTATIC &  
GEAR DRIVE  
SERIES D**

**⚠ WARNING:** The engine exhaust from this product contains chemicals known to the State of California to cause cancer, birth defects or other reproductive harm.

**SNAPPER®** McDonough, GA., 30253 U.S.A.

COPYRIGHT © 1999  
SNAPPER INC.  
ALL RIGHTS RESERVED

**MANUAL No. 3-5950 (Rev. 2, 5/99)**