

SNAPPER[®]

EUROPEAN REAR ENGINE RIDER SERIES 16 & 18

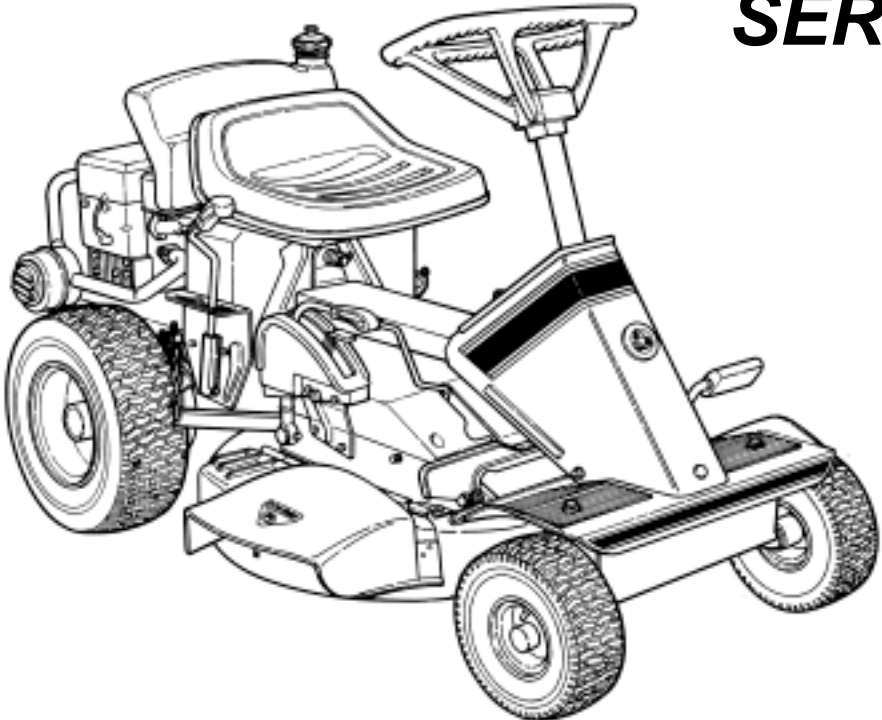

MODELS:
E250816BE
E281016BE
E281216BE
E281318BE
E331316BVE
E331416KVE
E331518KVE

CONTENTS

DESCRIPTION	PAGE(S)	DESCRIPTION	PAGE(S)
WHEELS, TIRES	2, 3	BELTS, BRAKES, INTERLOCK (28" / 33", Ser. 16)	25
FRONT END, STEERING	4, 5	BELTS, BRAKES, INTERLOCK (28" / 33", Ser. 18)	26, 27
MAIN CASE (Solid Seat Mount)	6, 7	DRIVE DISC ASSEMBLY	28
MAIN CASE (Hinged Seat Mount)	8, 9	FUEL TANK & OPERATORS SEAT	29
DIFFERENTIAL, R.H. FENDER	10, 11	ENGINE & EXHAUST MUFFLER	30
CHAIN CASE ASSEMBLY, L.H. FENDER	12, 13	THROTTLE CONTROLS	31
SMOOTH CLUTCH ASSEMBLY	14, 15	ELECTRICAL SYSTEMS (Briggs)	32, 33
CUTTING DECKS, DEFLECTORS	16, 17	ELECTRICAL SYSTEMS (Kohler)	34, 35
RAILS, LIFT ARMS, CAM LIFT (Series 16)	18, 19	WIRING SCHEMATICS	36, 37
RAILS, LIFT ARMS, CAM LIFT (Series 18)	20, 21	DECALS	38-41
BLADE STOP PEDALS	22	ACCESSORIES & ATTACHMENTS	42
SPINDLE ASSEMBLY	23	HARDWARE BAGS	43
BELTS, BRAKES, INTERLOCK (25", Series 16)	24		

SNAPPER[®] McDonough, GA., 30253 U.S.A.

COPYRIGHT © 1999
 SNAPPER INC.
 ALL RIGHTS RESERVED

WHEELS - FRONT

1 ASSEMBLY

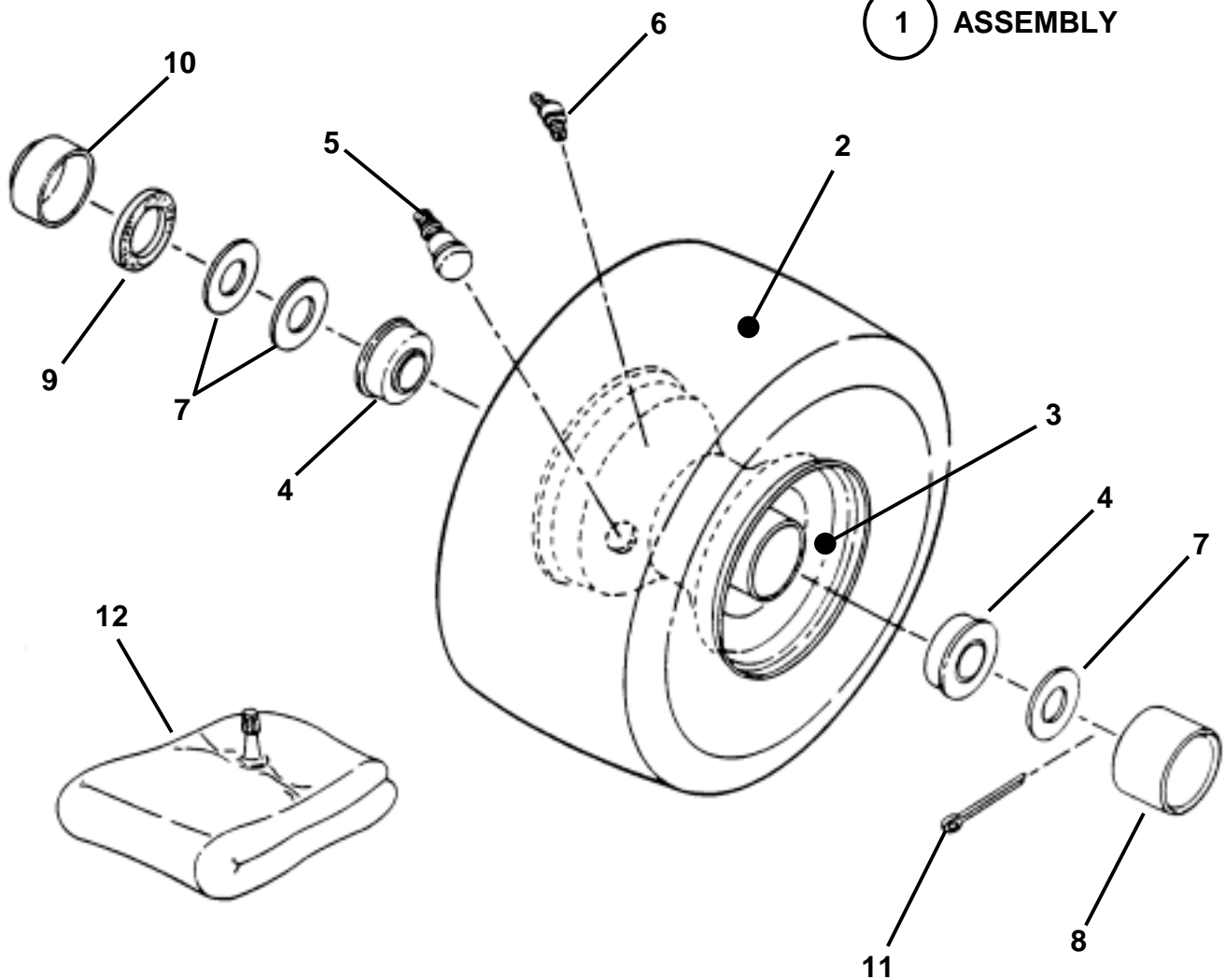

ITEM	PART NO.	DESCRIPTION
1	5-2268	ASSEMBLY, Front Tire & Rim (Complete) (Includes Items 2, 3, 4, 6, 12)
--	5-2267	ASSEMBLY, Front Tire & Rim (Includes Items 2 Thru 6)
2	2-3828	TIRE, 4.10/3.50 x 4
3	1-7146	RIM (For 4.10/3.50 x 4 Tire)
4	1-1807	BEARING, Ball
5	1-2234	VALVE, Air (Snap-in)
6	1-4669	FITTING Lube
7	1-0935	WASHER
8	1-1022	CAP, Hub
9	1-1032	SEAL, Felt
10	3-1038	CAP, Dust
11	9-1516	PIN, 5/32 x 1" Cotter
12	1-0821	TUBE, Inner (For 4.10/3.50 x 4 Tire)

WHEELS - REAR

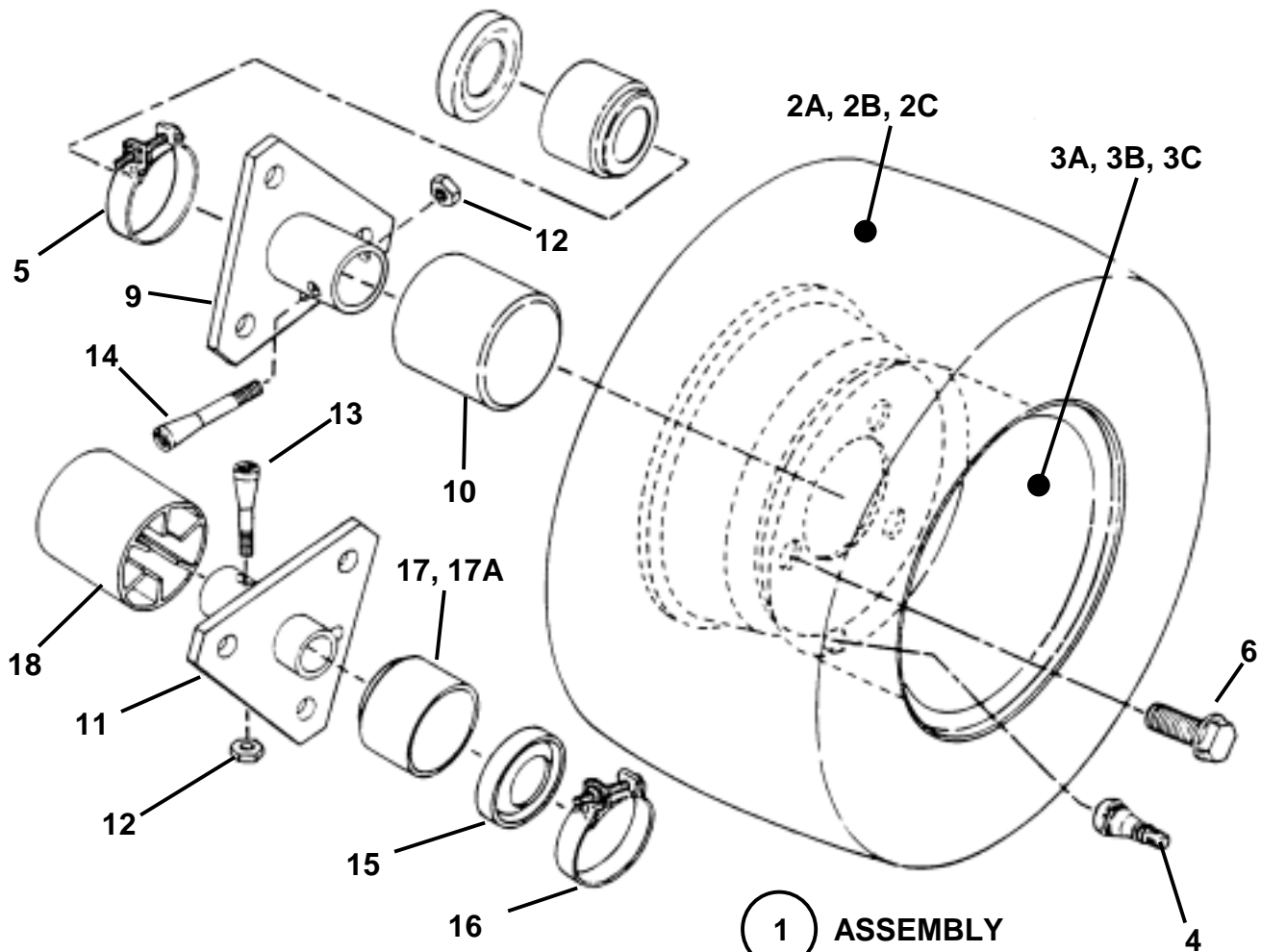

ITEM	PART NO.	DESCRIPTION
1	5-2269	ASSEMBLY, Rear Tire & Rim (Includes Items 2A, 3A, & 4) (25" Models)
--	5-2270	ASSEMBLY, Rear Tire & Rim (Includes Items 2B, 3B, & 4) (28" Models)
--	5-2671	ASSEMBLY, Rear Tire & Rim (Includes Items 2C, 3C, & 4) (33" Models)
2A	2-3889*	TIRE, Standard, 16-4.80 x 8 (25" Models)
2B	1-5968	TIRE, Wide, 16-6.50 x 8 (28" Models)
2C	2-2584	TIRE, Extra Wide, 16-7.50 x 8 (33" Models)
3A	1-2162	RIM, Standard, (For 16-4.80 x 8 Tire) (25" Models)
3B	1-2163	RIM, Wide, (For 16-6.50 x 8 Tire) (28" Models)
3C	1-7147	RIM, Extra Wide, (For 16/7.50 x 8 Tire) (33" Models)
4	1-2234	VALVE, Air (Snap-in)
5	1-2332	CLAMP, Right Hand (8, 10, 12, 13 & 15HP)
--	1-4542	CLAMP, Right Hand (13 & 14 HP)
6	9-1502	BOLT, 1/2-20 x 3/4" Lug, Grade 5 (6)
7	3-1732	BOOT, Right Hand (8, 10, 12 & 13HP)
--	1-4541	BOOT, Right Hand (13, 14 & 15 HP)
8	1-1817	SEAL, Oil
9	4-0433	HUB, Rear Wheel (Right Hand)
10	2-3895	CAP, Hub
11	4-0434	HUB, Rear Wheel
12	1-1201	NUT, 5/16-24 Hex Center Lock
13	1-1035	BOLT, 5/16-24 x 1-5/8" Tapered (Left Hand)
14	1-1013	BOLT, 5/16-24 x 2" Tapered (Right Hand)
15	1-4662	SEAL, Oil (Left Hand)
16	1-2332	CLAMP, (Left Hand) (13 & 14 HP)
17	1-4658	BOOT, Ball Bearing Models (Left Hand) (13 14 & 15HP Engines)
17A	3-5918	BOOT, Standard Models (Left Hand) (8, 10, 12 & 13HP Engines)
18	2-3522	CAP, Hub (Left Hand)

***NOTE:** 2-3889 accepts part # 1-0525 TUBE, 16-4.80 (optional)

FRONT END STEERING

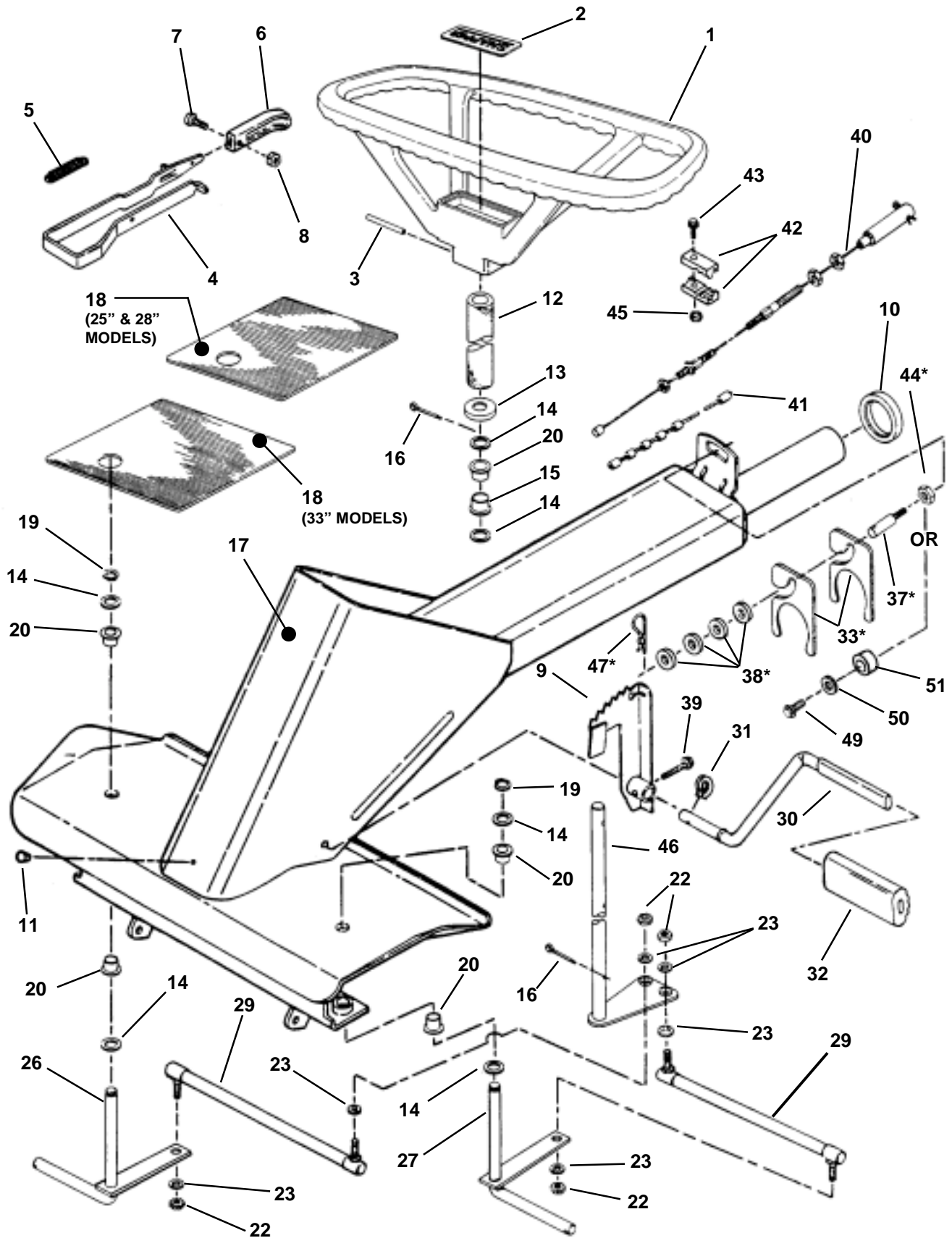

***NOTE: These parts are used on the 25" Model Only.**

FRONT END STEERING

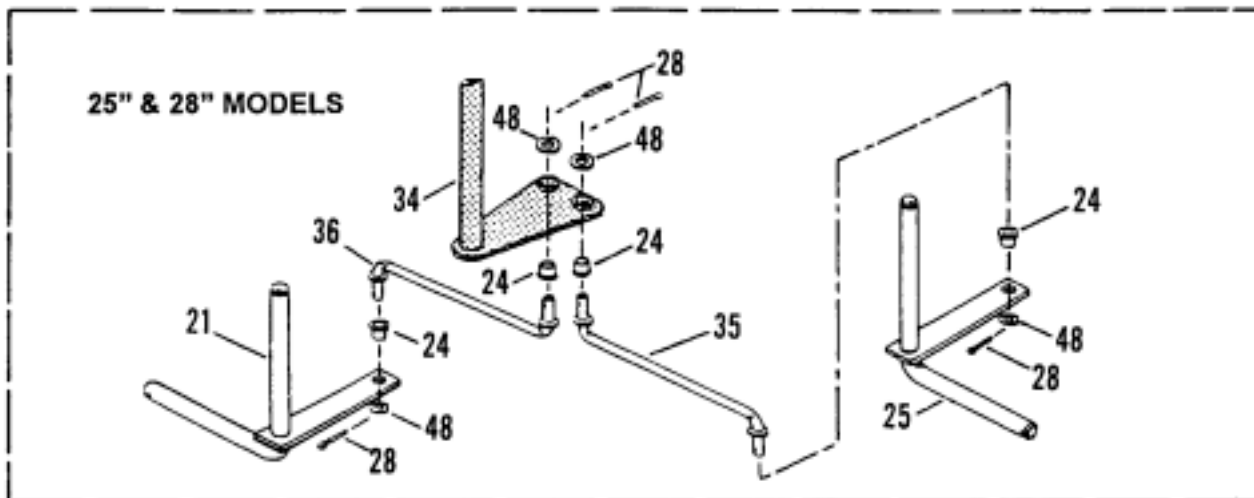

ITEM	PART NO.	DESCRIPTION	ITEM	PART NO.	DESCRIPTION
1	5-1941	ASSEMBLY, Steering Wheel (Includes Item 2)	23	9-1315*	WASHER, 5/16 Split Lock (4)
2	2-3781	LOGO, SNAPPER	24	1-3321	BUSHING, Nylon (4)
3	1-3862*	PIN, 1/4 x 1-1/2" Roll	25	4-1687	PIN, Narrow King (Left Side)
4	3-3882	LEVER, Clutch/Brake	26	4-1686	PIN, Wide King (Right Side)
5	2-3666	SPRING	27	4-1685	PIN, Wide King (Left Side)
6	2-3655	GRIP, Lever	28	9-1516	COTTER-PIN, 5/32 x 1" (2)
7	9-1017	SCREW, #8-32 x 3/8" Cross Recess	29	2-4935	TIE-ROD (33" Models) (2)
8	9-1018	NUT, #8-32 Hex	30	2-4735	PEDAL, Clutch/Brake
9	4-1476	ARM, Clutch/Brake	31	1-0739	RING, 5/8" External Retaining
10	2-2372	SPACER, Main Tube	32	1-2661	PAD, Clutch/Brake Pedal
11	1-6704	FASTENER, Panel	33	2-8395	SPACER, Pivot
12	2-3667*	COVER, Steering Shaft (Foam)	34	4-1381	SHAFT, Steering (Narrow Front End)
13	2-3671*	COVER	35	2-4915	TIE-ROD, Left Side (25" & 28" Models)
14	1-0935	WASHER, 3/4 Flat	36	2-4916	TIE-ROD, Right Side (25" & 28" Models)
15	1-9166	BUSHING, 3/4" Steering Shaft	37	2-8332	STUD, 3/8-24 x 5/8" Shoulder
16	9-1515*	COTTER-PIN, 3/16 x 1-1/2" (2)	38	2-2881	SPACER (2)
17	4-1654	WELDMENT, Front Frame (25" & 28" Models)	39	9-1151	SCREW, 5/16-18 x 1-1/4" Hex Washer Self-Tapping
--	4-1653	WELDMENT, Front Frame (33" Models)	40	2-2344	CABLE, Brake (Series 16) (shown)
18	2-3660	PAD, Foot (Right Side) (25" & 28" Models Shown)	--	7-1909	CABLE, Brake (Ser. 18)
--	2-3663	PAD, Foot (Right Side) (33" Model Shown)	41	2-9913	CABLE, Clutch
--	2-3659	PAD, Foot (Left Side) (25" & 28" Models - Not Shown)	42	3-4174	UNION, Cable
--	2-3662	PAD, Foot (Left Side) (33" Model - Not Shown)	43	9-1495	BOLT, 1/4-20 x 3/4" Hex Flange Lock
19	1-0746	RING, 5/8" Ext. Retaining (2)	44	9-0854	NUT, 3/8-24 Hex Nyloc
20	1-0986	BEARING, Nylon (5)	45	9-0372*	NUT, 1/4-20 Hex Center Lock
21	4-1688	PIN, Narrow King (Right Side)	46	4-1553	SHAFT, Steering (Wide Front End)
22	9-1297*	NUT, 5/16-24 Hex (4)	47	1-2867	HAIRPIN, 1/8 x 2-9/16"
			48	9-1514	WASHER, 3/8 Flat
			49	9-1198	SCREW, 3/8-16 x 5/8" Self-Tapping
			50	9-0517	WASHER, 3/8 Flat
			51	2-8774	SPACER, .39 x .625 x .19

*NOTE: These items are in 6-1792 Hardware Bag (see page 43 for complete list of hardware bag components).

MAIN CASE (Solid Seat Mount)

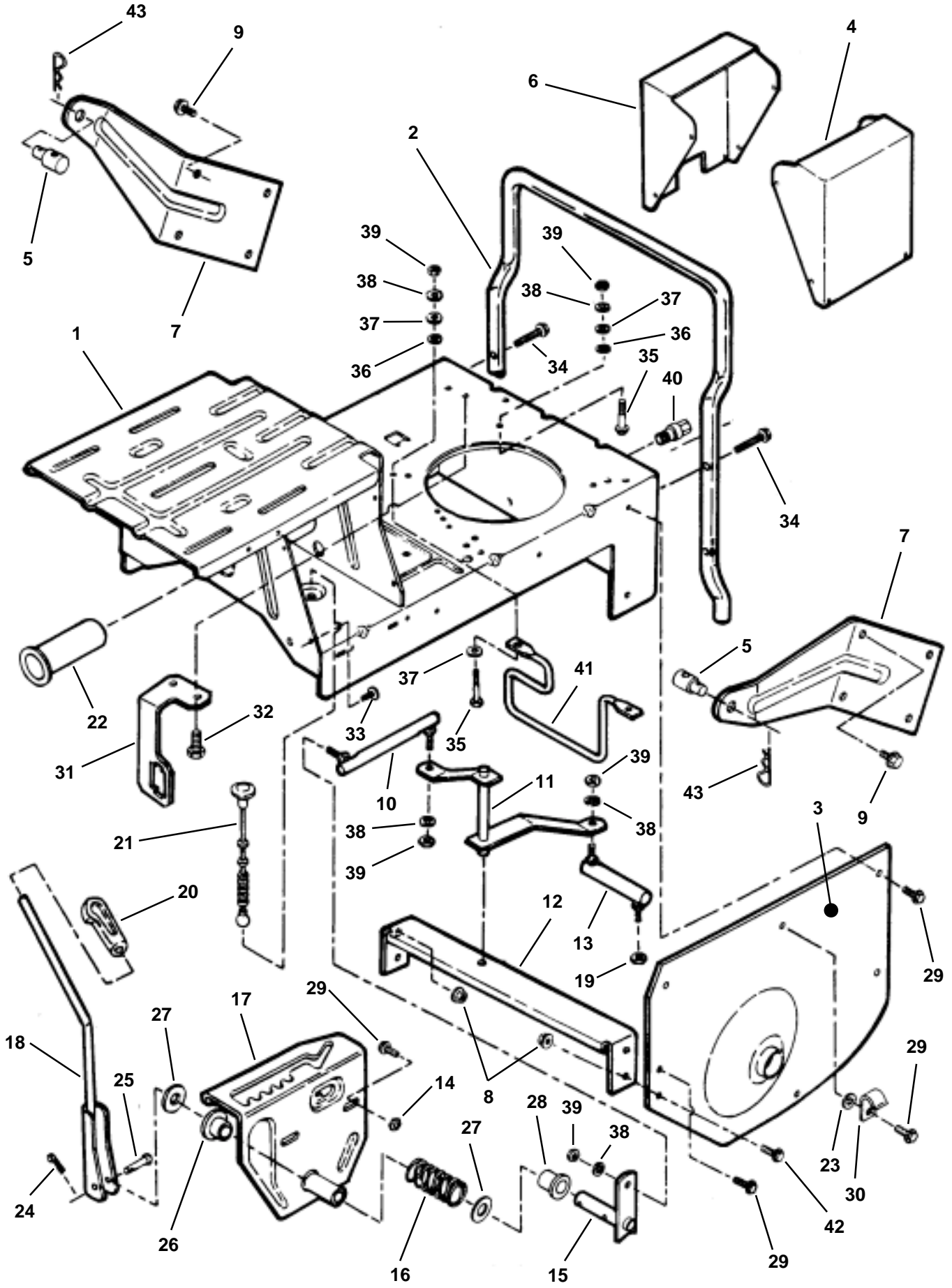

MAIN CASE (Solid Seat Mount)

ITEM	PART NO.	DESCRIPTION
1	4-2701	CASE, Main (Standard) (8 & 10HP)
2	3-6367	BUMPER, Rear
3	--	FENDER, Left Hand (See page 12 for related parts)
4	2-8990	COVER, Battery
5	2-8200	SWIVEL (2)
6	2-8989	COVER, Switch
7	3-4299	WING, Rear (2) (Models 28" & 33" Only!)
8	9-0585	NUT, 5/16-18 Hex Flange Lock (2)
9	9-0793	SCREW, 5/16-18 x 3/4" Self-Tapping (4)
10	2-3676	LINK, Shift (Long)
11	4-1384	ARM, Shift
12	3-3799	BRACE, Cross
13	1-1018	LINK, Shift (Short)
14	9-0196	NUT, 5/16-18 Hex (2)
15	4-0598	ARM, Shift Handle
16	1-0754	SPRING, Shift Handle
17	4-1232	DETENT, Shift
18	4-0599	HANDLE, Shift
19	1-0969	NUT, Hex Large Flange Lock 5/16-24
20	2-3656	KNOB, Shift Handle
21	2-7429	CABLE, Deck Support (5.5") (25" Models Only!)
22	2-2509	BUSHING, Pilot
23	9-0391	WASHER, 5/16 Internal Tooth Lock
24	9-0037	COTTER-PIN, 3/32 x 3/4"
25	2-3914	PIN, 1/4 x 1-3/4" Tapered Clevis
26	1-9245	BUSHING, Nylon
27	3-1036	WASHER, Thrust (2)
28	1-9246	BUSHING, Nylon (2)
29	9-0361	SCREW, 5/16-18 x 5/8" Self-Tapping (14)
30	1-2652	CLIP, Wire
31	3-4724	BRACKET, Switch
32	9-0981	SCREW, Self Tapping, 10-32 x 1/4"
33	9-1272	FASTENER, 1/4x3/4 Ratchet (6)
34	9-1506	SCREW, 5/16-18 x 1-1/2" Self-Tapping (4)
35	9-1513	SCREW, 5/16-24 x 1-3/4" Hex Head Cap (4)
36	1-1791	RETAINER, 5/16 Bolt (4)
37	9-1296	WASHER, 5/16" Flat (4)
38	9-1315	WASHER, 5/16" Split Lock (8)
39	9-1297	NUT, 5/16-24 Hex (8)
40	2-2486	DRAIN, Oil (Short)
41	1-7653	GUIDE, Belt (25" Models)
--	3-5971	GUIDE, Belt (28" Models)
42	9-0206	SCREW, 5/16-18 x 3/4" Hex Cap (2)
43	9-1503	HAIRPIN, 3/32 x 1-1/2" (2)

MAIN CASE (Hinged Seat Mount)

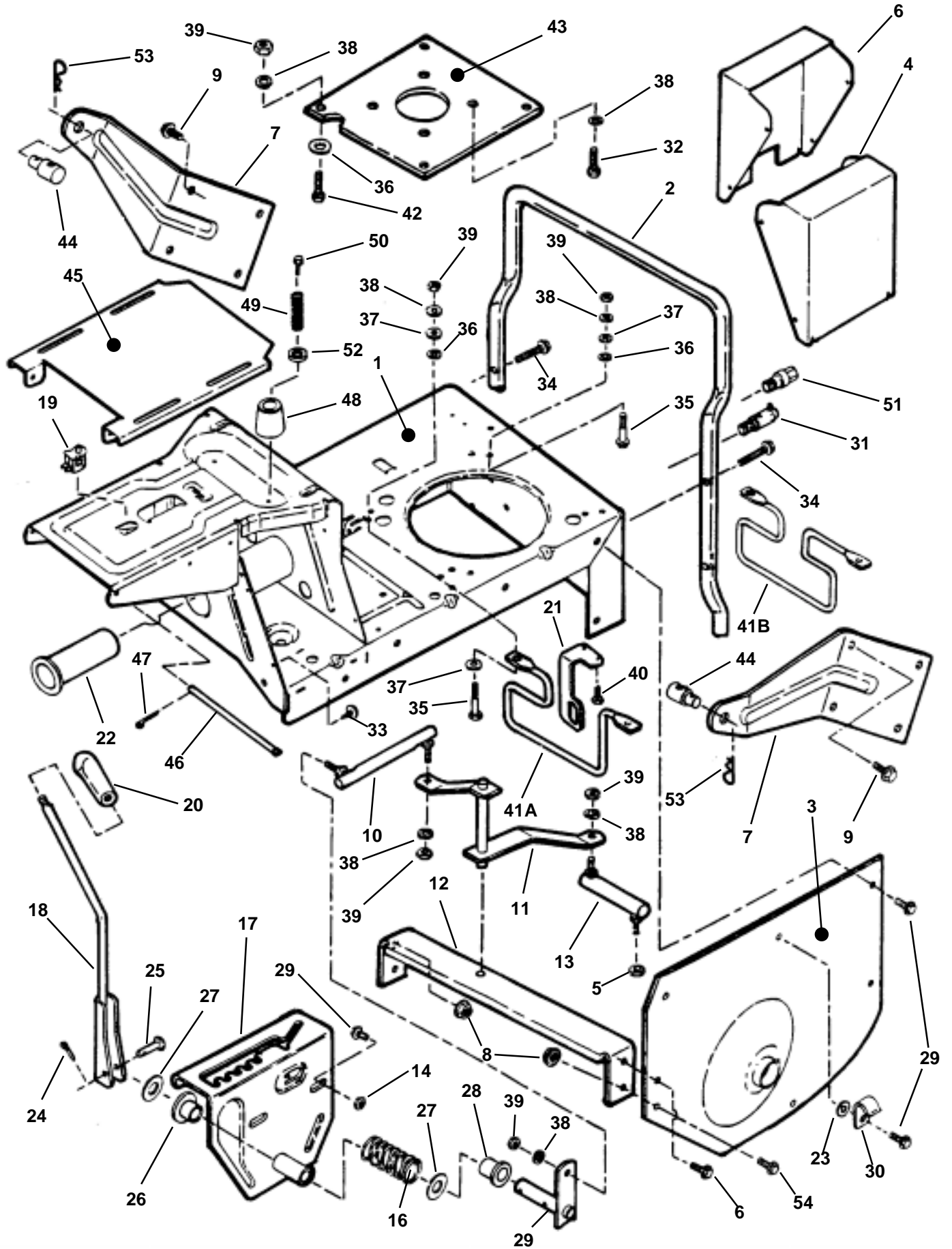

MAIN CASE (Hinged Seat Mount)

ITEM	PART NO.	DESCRIPTION	ITEM	PART NO.	DESCRIPTION
1	4-2700	CASE, Main (13 HP Briggs)	30	1-2652	CLIP, Wire (7/16")
--	4-2702	CASE, Main (14 HP Kohler)	31	2-7972	DRAIN, Oil (1/4 Turn) (Kohler)
2	3-6367	BUMPER, Rear	32	7-7692	BOLT, M8-1.25 x 25mm, Self-Tap (Kohler)
3	3-7285	FENDER, Left Hand (See page 12 for related parts) (Briggs)	33	9-1272	FASTENER, 1/4 x 3/4 Ratchet (6)
--	3-7958	FENDER, Left Hand (Kohler Engine)	34	9-1506	SCREW, 5/16-18 x 1-1/2" Hex Washer Self-Tap (4)
4	2-8990	COVER, Battery	35	9-1513	SCREW, 5/16-24 x 1-3/4" Hex Head Cap, Grade 5 (4)
5	1-0969	NUT, 5/16-24 Hex Flange Lock	36	1-1791	RETAINER, 5/16 Bolt (4)
6	2-8989	COVER, Switch	37	9-1296	WASHER, 5/16" Flat (4)
7	3-4299	WING, Rear (Models 28" & 33" Only!) (2)	38	9-1315	WASHER, 5/16" Split Lock (8)
8	9-0585	NUT, 5/16-18 Hex Fl. Lock (2)	39	9-1297	NUT, 5/16-24 Hex (8)
9	9-0793	SCREW, 5/16-18 x 3/4" Hex Washer Self-Tap (4)	40	9-1080	SCREW, #10-24 x 1/4" Hex Washer Self Tap (2)
10	2-3676	LINK, Shift (Long)	41A	3-6419	GUIDE, Belt (33" Kohler)
11	4-1384	ARM, Shift	41B	3-5971	GUIDE, Belt (28" Briggs)
12	3-3799	BRACE, Cross	42	9-0238	SCREW, 5/16-24 x 1" Hex Head Cap, Grade 5 (4)
13	1-1018	LINK, Shift (Short)	*43	3-4093	PLATE, Engine
14	9-0196	NUT, 5/16-18 Hex (2)	44	2-8200	SWIVEL (2)
15	4-0598	ARM, Shift Handle	45	3-4664	PLATE, Seat
16	1-0754	SPRING, Shift Handle	46	2-8656	PIN, Hinge
17	4-1232	DETENT, Shift	47	9-0360	PIN, 1/16 x 3/4", Cotter
18	4-0599	HANDLE, Shift	48	2-8540	CUSHION
19	2-3354	SWITCH, Seat	49	2-8657	SPRING, Seat O.P.C.
20	2-3656	KNOB, Shift Handle	50	9-0999	SCREW, 1/4-20 x 5/8" Self-Tap, Truss Head, Torx
21	3-4724	BRACKET, Switch	51	2-2486	DRAIN, Oil (Briggs)
22	2-2509	BUSHING, Pilot	52	9-1294	WASHER, 9/32" I.D. x 5/8" O.D.
23	9-0391	WASHER, 5/16 Internal Tooth Lock	53	9-1503	HAIRPIN, 3/32 x 1-1/2" (2)
24	9-0037	PIN, 3/32 x 3/4" Cotter	54	9-0206	SCREW, 5/16-18 x 3/4" Hex Head Cap, Grade 5 (2)
25	2-3914	PIN, 1/4 x 1-3/4" Tapered Clevis			
26	1-9245	BUSHING, Nylon			
27	3-1036	WASHER, Thrust (2)			
28	1-9246	BUSHING, Nylon (2)			
29	9-0361	SCREW, 5/16-18 x 5/8" Hex Washer Self-Tap (13)			

*** NOTE: ITEM 43 IS USED ON 14 HP KOHLER ENGINES ONLY!**

DIFFERENTIAL, R. H. FENDER

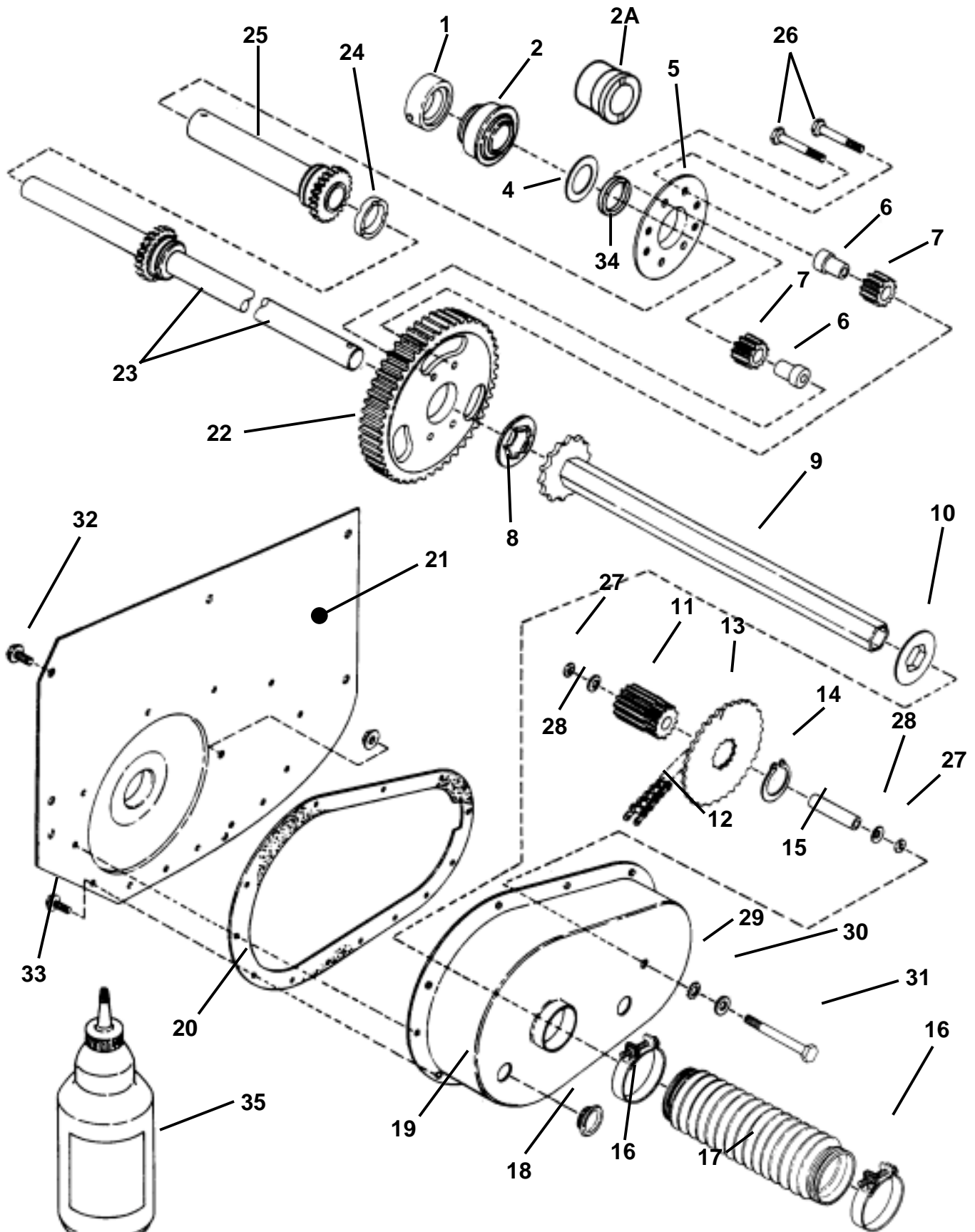

MANUAL No. 06103

R. E. RIDER (EURO) SERIES 16 & 18

DIFFERENTIAL, R. H. FENDER

ITEM	PART NO.	DESCRIPTION
1	1-4401	COLLAR, Lock (Includes P.N. 9-0201 Set screw)
2	1-8822	BALL BEARING, Axle (R. H. Fender) (33" Models - 13 & 14 HP)
2A	1-2296	BEARING, Axle (R. H. Fender) (25" & 28" Models – 8, 10 & 13HP)
3	1-0969	NUT, 5/16-24 Hex Flange Lock
4	3-1079	WASHER, Thrust
5	3-8067	PLATE, Differential
6	2-2115	SPACER, Pinion (4)
7	2-1127	GEARS, Differential Pinion
8	1-1072	WASHER, Thrust
9	5-1584	ASSEMBLY, Drive Hex Tube
10	1-0988	WASHER, Hex Nylon Splash
11	1-0964	GEAR, 11 Teeth-10 Pitch
12	1-0941	CHAIN, 46 Pitch (#35)
13	2-1129	SPROCKET
14	1-0965	RING, Retaining
15	2-1128	SPACER
16	1-2332	CLAMP, Boot (2)
17	1-7083	BOOT, Oil Seal
18	1-1024	PLUG, Oil Fill & Check
19	3-7279	CASE, Transmission
20	2-8762	GASKET, Transmission Case
21	3-7957	FENDER, Right Hand (33" Ball Bearing Differential Models) (2.498" hole)
--	3-7280	FENDER, Right Hand (25" & 28" Bushing Differential Models) (1.62" hole)
22	2-1158	GEAR, 63 Teeth-10 Pitch
23	4-7763	AXLE, Long (Includes Gear) (Use Only With Short Axle P.N. 5-7398)
24	1-1026	SPACER
25	5-7398	AXLE, Short (Includes Gear) (Use Only With Long Axle P.N. 4-7763)
26	1-2333	SCREW, 5/16-24 x 1-5/8" Hex Cap Special Lock (4)
27	1-1156	O-RING, 5/16 (2)
28	1-1782	WASHER, Belleville (2)
29	9-0395	WASHER, 5/16 External Tooth Lock
30	9-0188	WASHER, 5/16 Flat
31	1-1042	BOLT, 5/16-24 x 2-5/8" Idler
32	9-0361	SCREW, 5/16-18 x 5/8" Self-Tapping (11)
33	9-0362	SCREW, 1/4-20 x 5/8" Self-Tapping (13)
34	3-2107	SPACER, Short Axle
35	6-1017	GREASE, Transmission
--	6-0411	KIT, Differential (Includes items 2A & 3-7280 Fender)
--	6-0662	KIT, Differential (Includes items 2 & 3-7957 Fender)

CHAIN CASE, L. H. FENDER

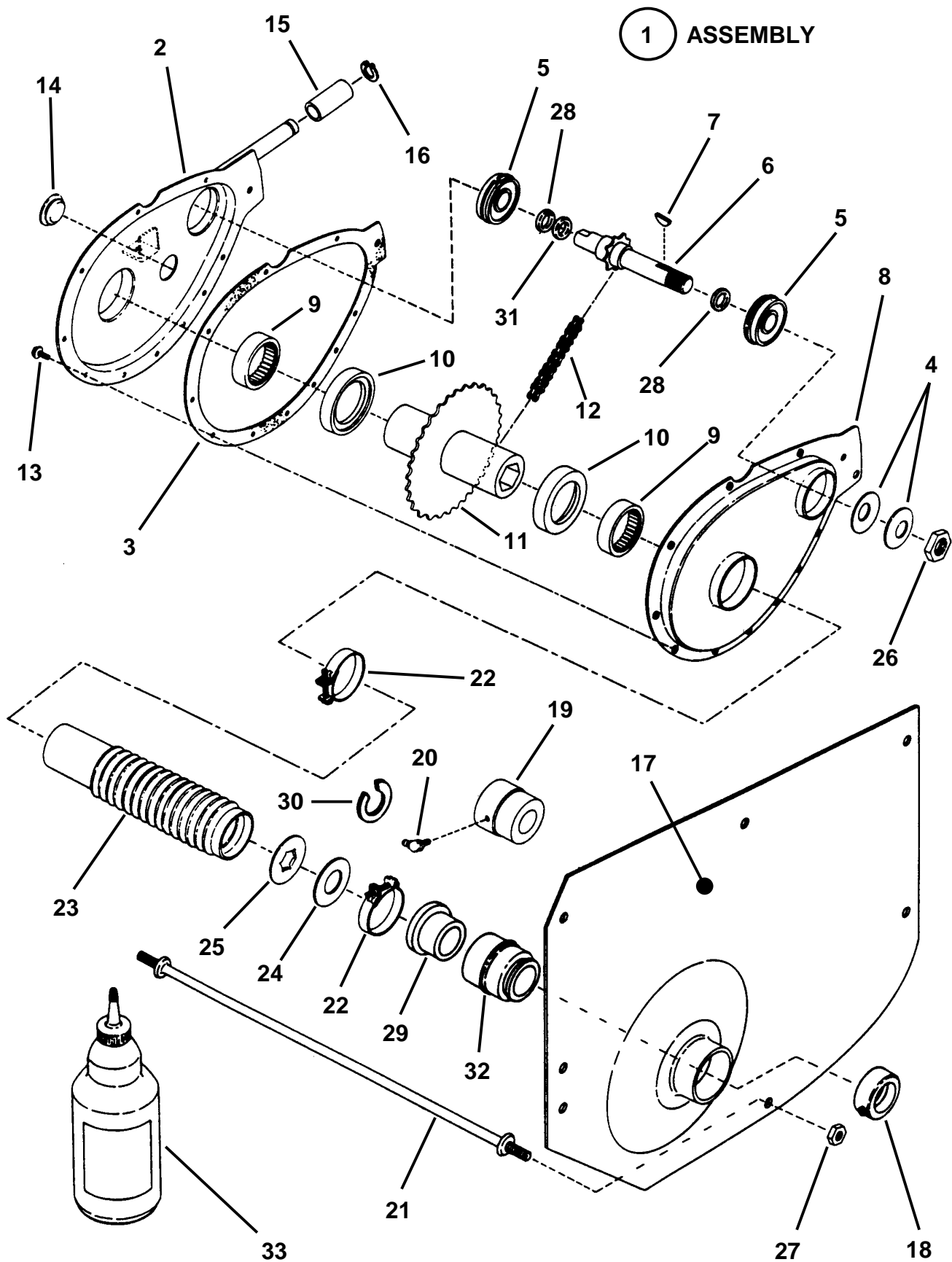

CHAIN CASE, L. H. FENDER

ITEM	PART NO.	DESCRIPTION
1	5-2683	ASSEMBLY, Chain Case (Includes Items 2 Thru 13,15,16, & 31 Thru 33)
2	4-1136	CASE, Sprocket
3	2-8761	GASKET, Case Cover
4	1-1121	WASHER, Belleville (2)
5	1-0756	BEARING, Ball (2)
6	1-8963	SPROCKET & SHAFT
7	1-0614	KEY, 1/8 x 5/8" Woodruff
8	3-9778	COVER, Chain Case
9	1-0942	BEARING, Needle (2)
10	1-1086	WASHER, Nylon Thrust (2)
11	4-0355	HUB & SPROCKET
12	1-0941	CHAIN
13	9-0307	SCREW, #10-24 x 5/8" Hex Washer Self-Tap (10)
14	1-1024	PLUG, Oil Fill & Check
15	2-2785	ROLLER
16	1-0776	RING, 1/2" External Retaining (Heavy Duty)
17	3-7285	FENDER, Left Hand (25" & 28" Models) (1.628" I. D. hole)
--	3-7958	FENDER, Left Hand (33" Models) (1.744" I. D. hole)
18	1-4625	COLLAR, Lock (Includes P.N. 9-0776 Set Screw, 1/4-20 x 1/4") (Used with ball bearing, item 32, only)
19	5-0918	BEARING, Left Hand Fender (Includes Item 20) (25" & 28" Models, 8 & 10 HP)
20	1-3324	FITTING, Lube
21	1-1070	ROD, Cross-Tie
22	1-2332	CLAMP, Boot (2)
23	1-7084	BOOT, Oil Seal
24	1-1071	WASHER, Thrust Nylon
25	1-1072	WASHER, Thrust
26	9-1505	NUT, 5/8-18 Hex Nyloc
27	1-0969	NUT, 5/16-24 Hex Flange Lock
28	1-9260	O-RING (2)
29	2-3447	SPACER
30	1-2271	WASHER, Shim (As Required)
31	2-7981	WASHER, Shim (6)
32	1-4624	BALL BEARING, Left Hand Fender (33" Models)
--	5-1451	ASSEMBLY, Left Hand Fender (Includes Fender P.N. 3-7958 & Bearing P.N. 1-4624) (33" Models, 13 & 14 HP)
33	6-1017	GREASE, Transmission (Use 2 oz. maximum)

NOTE: See Pages 14 & 15 For Illustration Of Brake Lever Assembly & Related Parts.

SMOOTH CLUTCH ASSEMBLY

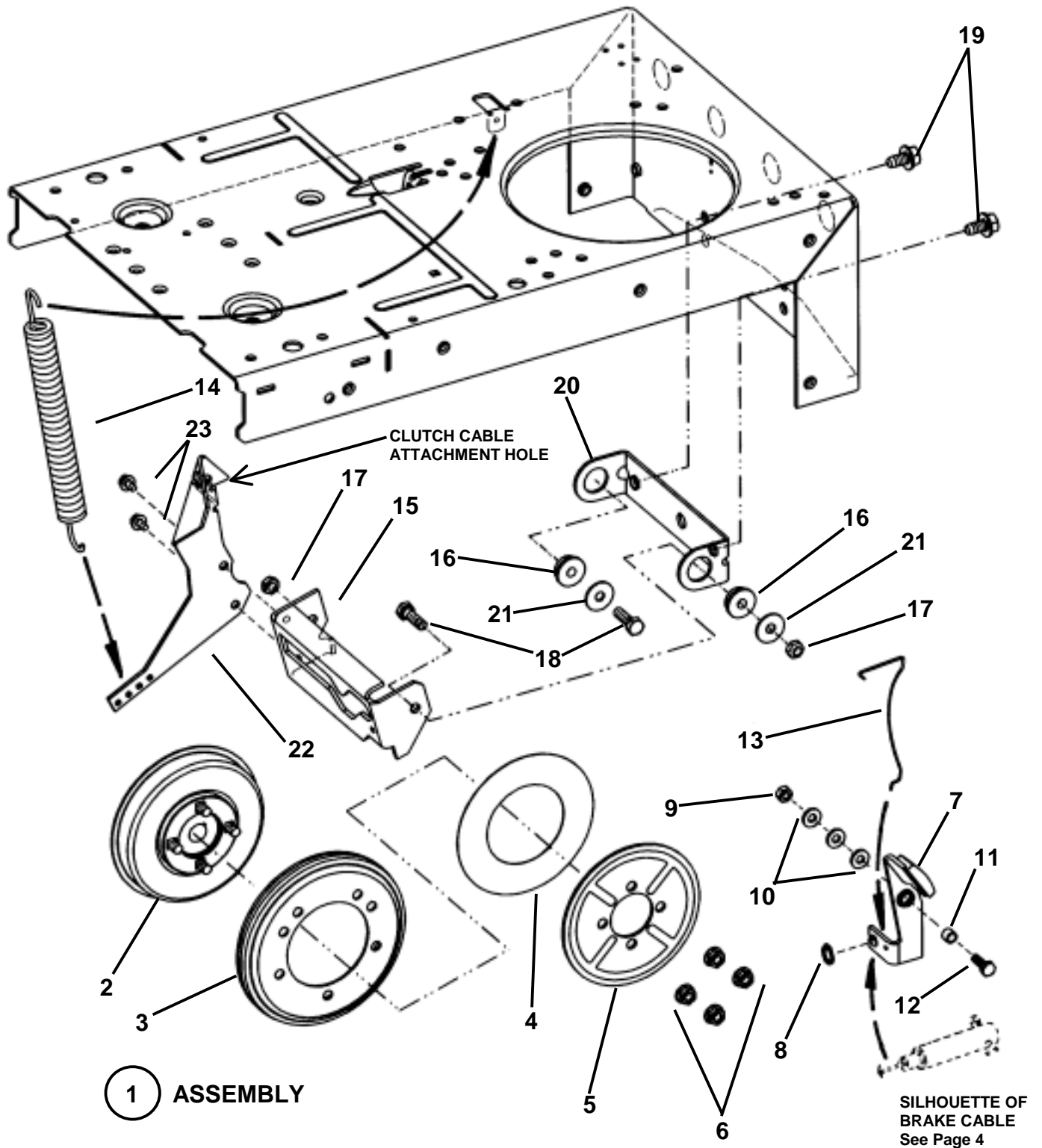

SMOOTH CLUTCH ASSEMBLY

ITEM	PART NO.	DESCRIPTION
1	5-3114	ASSEMBLY, Smooth Clutch (Includes Items 2 Thru 6)
2	5-4243	HUB, Driven Disc
3	5-3103	DISC, Driven
4	1-4523	WASHER, Thrust
5	3-2331	PLATE
6	9-0585	NUT, 5/16-18 Hex Flange Lock (4)
7	5-2497	ASSEMBLY, Brake Lever (Includes Brake Lining & Rivet)
8	1-2313	RING, 3/8" External Retaining
9	9-0303	NUT, 1/4-28 Hex Top Lock
10	9-1294	WASHER, 1/4 Flat (3)
11	1-0916	SPACER
12	9-1504	SCREW, 1/4-28 x 1" Hex Head Cap, Grade 5
13	2-2371	SPRING, Brake Return
14	1-2264	SPRING, Clutch Brake
15	3-3292	LIFT, Yoke
16	1-1048	BEARING, Yoke (2)
17	1-1201	NUT, 5/16-24 Hex Center Lock (2)
18	9-0238	SCREW, 5/16-24 x 1" Hex Head Cap, Grade 5 (2)
19	9-1198	SCREW, 3/8-16 x 5/8" Hex Washer Self-Tap
20	3-3291	COLLAR, Yoke
21	1-1763	WASHER, 5/16 Flat (2)
22	3-4725	ARM, Yoke
23	9-1084	SCREW, 1/4-20 x 3/8" Hex Washer Self-Tap (2)

CUTTING DECKS, DEFLECTORS

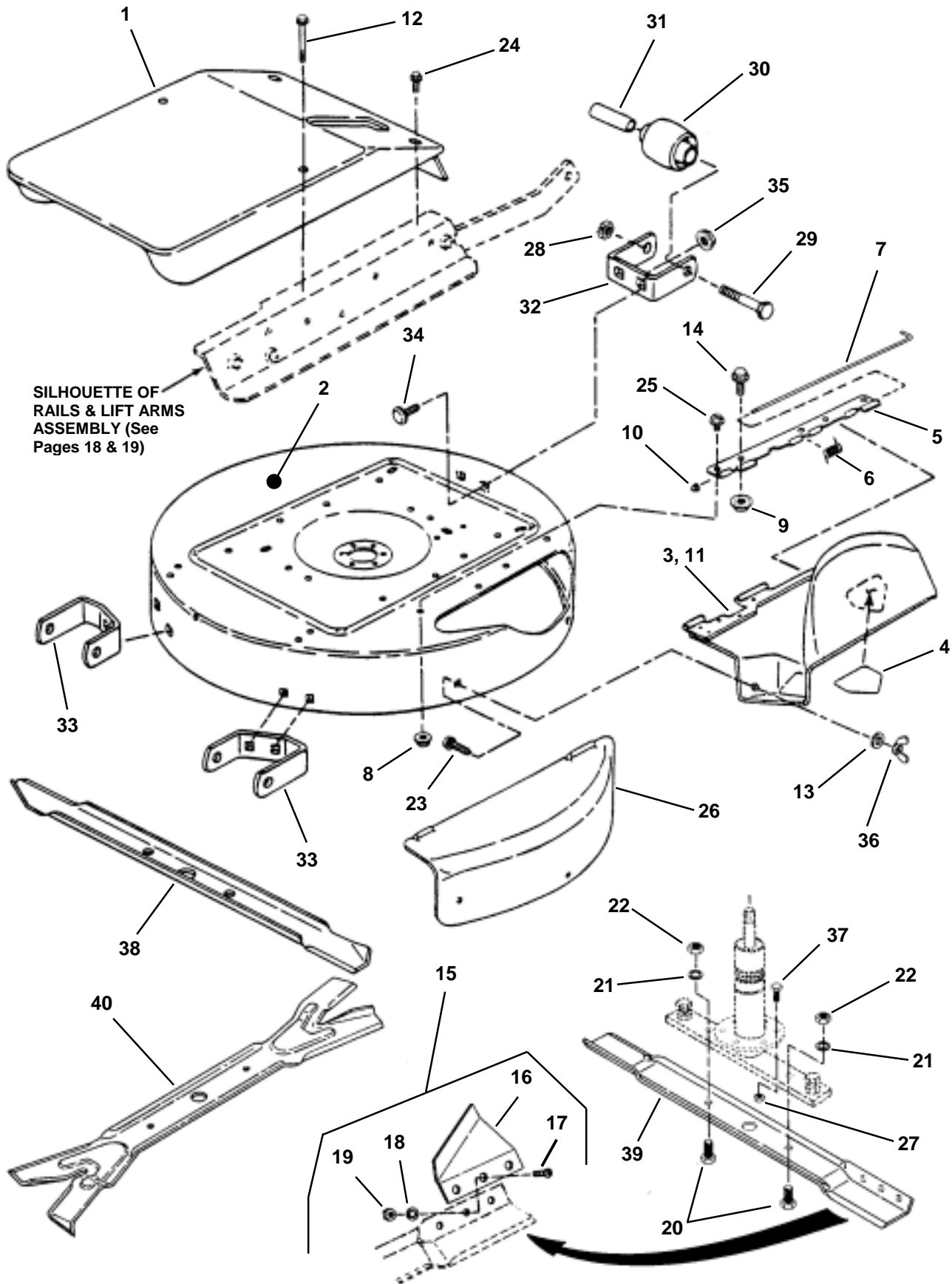

CUTTING DECKS, DEFLECTORS

ITEM	PART NO.	DESCRIPTION
1	2-8994	COVER, Spindle
2	6-1969	DECK, 25" Replacement (Painted deck with decals)
--	6-1970	DECK, 28" Replacement (Painted deck with decals)
--	6-1972	DECK, 33" Replacement (Painted deck with decals)
3	5-2555	DEFLECTOR, Discharge (28" & 33" Deck) (Includes Items 4, 5, 6, 7 & 10)
4	2-2841	DECAL, DANGER (Cut Finger)
5	3-3780	HINGE, Deflector
6	1-6341	SPRING, Hinge
7	2-6234	PIN, Hinge
8	9-1070	NUT, 5/16-18 Hex Flange Lock
9	9-0583	NUT, 1/4-20 Hex Flange Lock
10	2-6483	NUT, Push (2)
11	5-1976	DEFLECTOR, Discharge (25" Deck) (Includes Item 4)
--	5-7624	ASSEMBLY, Discharge (25" Deck)(Incl. 25" Side Chute, Hinge Ass'y & Decal)
12	9-1015	SCREW, 1/4-20 x 3-1/2" Hex Washer Self-Tap, Gr. 5 (2)
13	9-1296	WASHER, 5/16 Flat (2)
14	9-0584	BOLT, 1/4-20 x 1/2" Hex Flange Lock
15	6-0480	KIT, Air Lift (25", 28" & 33" Models) (Includes 16 Thru 19)
16	3-7723	AIR-LIFT (2) (25", 33" Models)
17	9-0228	SCREW, 5/16-24 x 11/16" Machine (6)
18	9-0391	WASHER, 5/16-24 Internal Tooth Lock (6)
19	9-0223	NUT, 5/16-24 Hex (6)
20	9-0392	SCREW, 1/2-20 x 1" Hex Head Cap, Grade 5 (2)
21	9-0509	WASHER, 1/2 Internal Tooth Lock (2)
22	9-0559	NUT, 1/2-20 Hex Jam (2)
23	9-1508	BOLT, 5/16-18 x 3/4" Short Neck Carriage, Grade 5 (2)
24	9-1016	SCREW, 1/4-20 x 5/8" Hex Self-Tap w/ Captured Washer (4)
25	9-1510	BOLT, 5/16-18 x 1/2" Hex Flange Lock (3)
26	1-6968	COVER, 25" Mulcher
--	1-6983	COVER, 28" Mulcher
--	1-6984	COVER, 33" Mulcher
27	9-0613	NUT, 3/8-16 Hex Flange Lock (9)
28	9-1518	NUT, 3/8-24 Hex Nyloc (3)
29	9-1532	SCREW, 3/8-24 x 3-3/4" Hex Head Cap, Grade 5 (3)
30	1-9190	WHEEL, Gage (3)
31	1-5272	SPACER (3)
32	3-3570	BRACKET, Gage Wheel (Front)
33	3-3571	BRACKET, Gage Wheel (Rear) (2)
34	9-0731	BOLT, 5/16-18 x 1/2" Short Neck Carriage, Grade 5 (6)
35	9-1070	NUT, 5/16-18 Hex Flange Lock (8)
36	9-0492	NUT, 5/16-18 Wing (2)
37	9-0612	BOLT, 3/8-16 x 3/4" Hex Flange Lock (3)
38	1-6967	BLADE, 25" Mulcher
--	1-6980	BLADE, 28" Mulcher
--	1-6982	BLADE, 33" Mulcher
39	1-9518	25" BLADE
--	1-9515	28" BLADE
--	1-9523	33" BLADE
40	2-9143	BLADE, Ninja, 25"
--	2-6453	BLADE, Ninja, 28"
--	2-4741	BLADE, Ninja, 33"

**RAILS, LIFT ARMS, CAM LIFT
(25", 28", & 33" Models) (Series 16)**

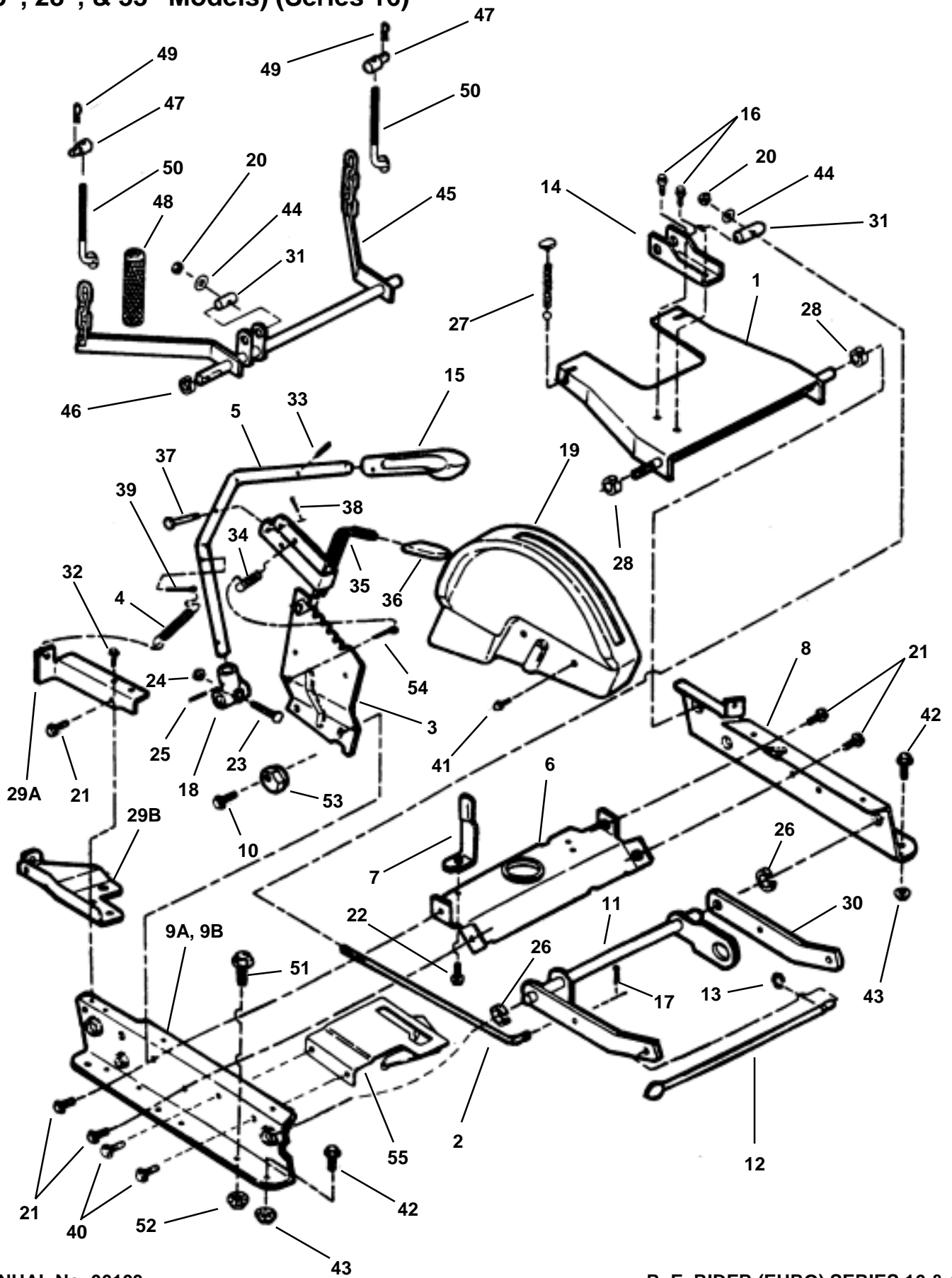

(25", 28" & 33" Models) (Series 16)

ITEM	PART NO.	DESCRIPTION	ITEM	PART NO.	DESCRIPTION
1	4-1389	ARM, Rear Lift (25" Deck Only)	30	3-2997	ARM, Front Lift-Left (28, 30" & 33" Decks)
2	1-6122	ROD, Leveling	31	3-4213	PIVOT, Leveling
3	4-2649	WELDMENT, Quadrant,5 Position	32	9-1084	SCREW, 1/4-20 x 3/4" Hex Washer Self-Tap
4	2-4914	SPRING, Extension	33	9-0844	PIN, 3/16 x 3/4" Roll
5	2-4878	LEVER, Lift	34	1-9410	SPRING, Latch (Black)
6	3-1838	BRACE, Top	35	4-1470	WELDMENT, Latch
7	3-1855	GUIDE, Belt	36	2-6286	GRIP, Lift Latch
8	3-4918	RAIL, Left Hand	37	1-1021	PIN, 1/4 x 1-1/4" Clevis
9A	3-6430	RAIL, R.H. (25" Deck)	38	9-0360	PIN, 1/16 x 3/4" Cotter
9B	4-3848	RAIL, R.H. (28", 30" & 33" Decks)	39	9-0753	PIN, 3/16 x 1-1/2" Cotter
10	9-0815	SCREW, 3/8-16 x 3/4" Hex Washer Head Self-Tap	40	9-0858	SCREW, 5/16-18 x 1/2" Hex Washer Self-Tap
11	4-0685	ARM, Front Lift, Adjustable (28", 30 & 33" Decks)	41	9-1016	SCREW, 1/4-20 x 5/8" Hex Washer Self-Tap
12	2-2717	ROD, Support (Front Lift Arm to Front End)	42	9-0606	BOLT, 5/16-18 x 5/8" Hex Flange Lock (3)
13	1-7847	SNAP RING, 7/16" External	43	9-0585	NUT, 5/16-18 Hex Flange Lock(3)
14	3-3008	ARM, Leveling (25" Deck)	44	9-0122	WASHER, 3/8" Flat
15	2-3658	GRIP, Height Adjustment Lever	45	4-1627	WELDMENT, Rear Lift Arm (28", 30" & 33" Decks)
16	9-1001	SCREW, 5/16-18 x 5/8" Truss Head Self-Tap (Torx) (2)	46	1-2068	RING, Blue
17	9-0365	PIN, 1/8 x 3/4" Cotter	47	2-8200	SWIVEL
18	2-5049	HUB, Deck Lift	48	2-8021	COVER, Chain
19	2-6394	COVER, Height of Cut	49	9-1503	HAIRPIN, 3/32 x 1-1/2"
20	9-0854	NUT, 3/8-24 Hex Nyloc	50	2-8728	ADJUSTER, Chain (2)
21	9-1198	SCREW, 3/8-16 x 5/8" Hex Washer Self-Tap (6)	51	9-0584	BOLT, 1/4-20 x 1/2" Hex Flange Lock
22	9-0361	SCREW, 5/16-18 x 5/8" Hex Washer Self-Tap	52	9-0583	NUT, 1/4-20 Hex Flange Lock
23	9-1164	BOLT, 5/16-24 x 1-5/8" Tapered Axle	53	3-5787	ECCENTRIC, Height-of-Cut
24	9-0480	NUT, 5/16-24 Hex Flange Lock	54	9-0357	COTTER-PIN, 3/16 x 3/4"
25	1-3550	PIN, 3/16 x 1" Roll	55	5-3923	ASSEMBLY, Clutch Plate
26	1-2067	RING, Red (2)			
27	2-7429	CABLE, Rear Deck (25" Deck)			
28	2-2112	RING, White (2) (25" Deck)			
29A	2-4762	BRACKET, Deck Lift (25" Deck Only!)			
29B	3-4695	BRACKET, Lift Assist (28", 30" & 33" Decks)			

**RAILS, LIFT ARMS, CAM LIFT
(28" & 33" Models) (Series 18)**

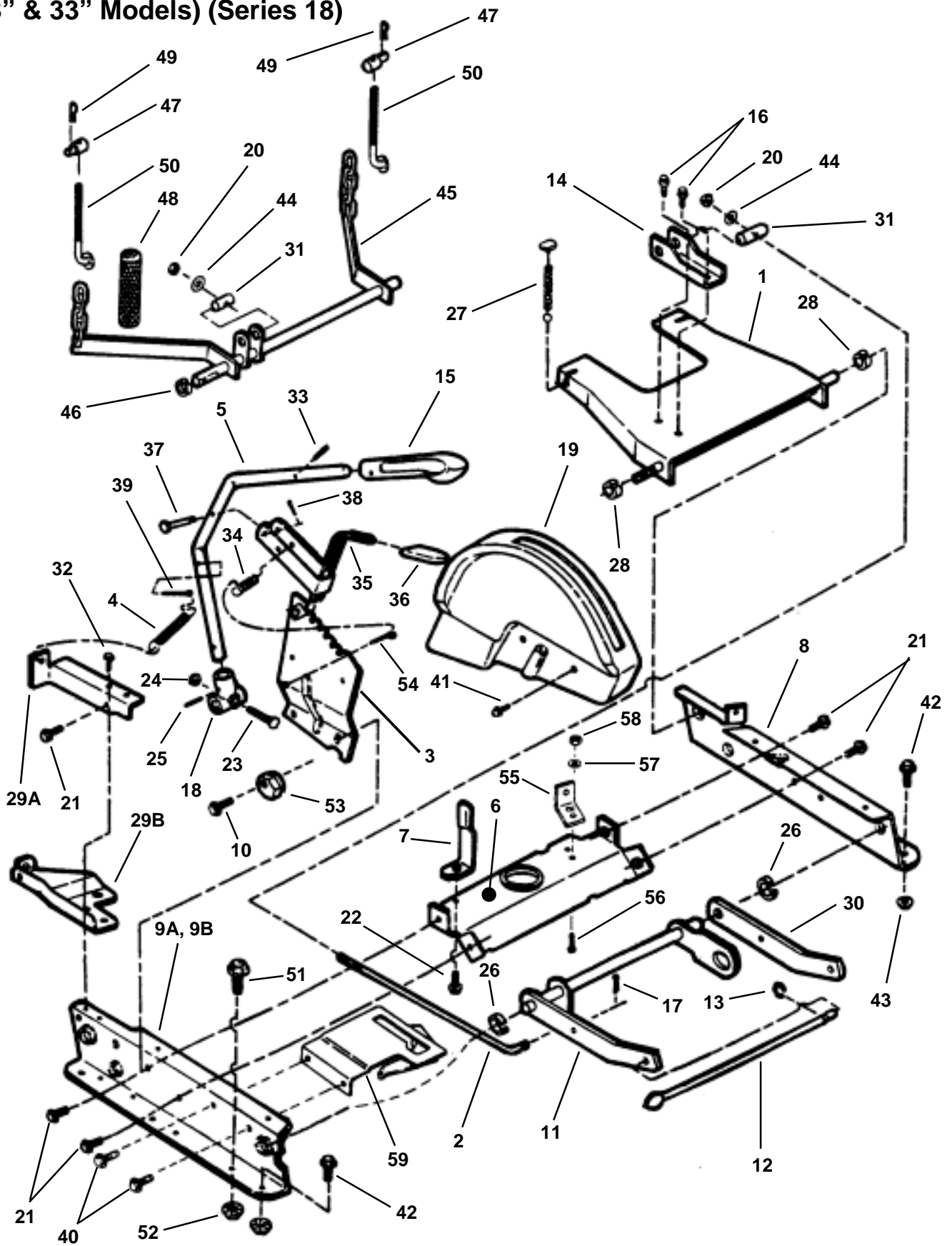

RAILS, LIFT ARMS, CAM LIFT (28" & 33" Models) (Series 18)

ITEM	PART NO.	DESCRIPTION	ITEM	PART NO.	DESCRIPTION
1	4-1389	ARM, Rear Lift (25" Deck Only)	30	3-2997	ARM, Front Lift-Left (28, 30" & 33" Decks)
2	1-6122	ROD, Leveling	31	3-4213	PIVOT, Leveling
3	4-2649	WELDMENT, Quadrant,5 Position	32	9-1084	SCREW, 1/4-20 x 3/4" Hex Washer Self-Tap
4	2-4914	SPRING, Extension	33	9-0844	PIN, 3/16 x 3/4" Roll
5	2-4878	LEVER, Lift	34	1-9410	SPRING, Latch (Black)
6	3-1838	BRACE, Top	--	3-5669	SPRING, Latch (Purple)
7	3-1855	GUIDE, Belt	35	4-1470	WELDMENT, Latch
8	3-4918	RAIL, Left Hand	36	2-6286	GRIP, Lift Latch
9A	3-6430	RAIL, R.H. (25" Deck)	37	1-1021	PIN, 1/4 x 1-1/4" Clevis
9B	4-3848	RAIL, R.H. (28", 30" & 33" Decks)	38	9-0360	PIN, 1/16 x 3/4" Cotter
10	9-0324	SCREW, 3/8-16 x 1" Hex Washer Self-Tap	39	9-0753	PIN, 3/16 x 1-1/2" Cotter
11	4-0685	ARM, Front Lift, Adjustable (28", 30 & 33" Decks)	40	9-0858	SCREW, 5/16-18 x 1/2" Hex Washer Self-Tap
12	2-2717	ROD, Support (Front Lift Arm to Front End)	41	9-1016	SCREW, 1/4-20 x 5/8" Hex Washer Self-Tap
13	1-7847	SNAP RING, 7/16" External	42	9-0606	BOLT, 5/16-18 x 5/8" Hex Flange Lock (3)
14	3-3008	ARM, Leveling (25" Deck)	43	9-0585	NUT, 5/16-18 Hex Flange Lock(3)
15	2-3658	GRIP, Height Adjustment Lever	44	9-0122	WASHER, 3/8" Flat
16	9-1001	SCREW, 5/16-18 x 5/8" Truss Head Self-Tap (Torx) (2)	45	4-1627	WELDMENT, Rear Lift Arm (28", 30" & 33" Decks)
17	9-0365	PIN, 1/8 x 3/4" Cotter	46	1-2068	RING, Blue
18	2-5049	HUB, Deck Lift	47	2-8200	SWIVEL
19	2-6394	COVER, Height of Cut	48	2-8021	COVER, Chain
20	9-0854	NUT, 3/8-24 Hex Nylon	49	9-1503	HAIRPIN, 3/32 x 1-1/2"
21	9-1138	SCREW, 3/8-16 x Hex Washer Self-Tap (6)	50	2-8728	ADJUSTER, Chain (2)
22	9-0361	SCREW, 5/16-18 x 5/8" Hex Washer Self-Tap	51	9-0584	BOLT, 1/4-20 x 1/2" Hex Flange Lock
23	9-1164	BOLT, 5/16-24 x 1-5/8" Tapered Axle	52	9-0583	NUT, 1/4-20 Hex Flange Lock
24	9-0480	NUT, 5/16-24 Hex Flange Lock	53	3-5787	ECCENTRIC, Height-of-Cut
25	1-3550	PIN, 3/16 x 1" Roll	54	9-0357	COTTER-PIN, 3/16 x 3/4"
26	1-2067	RING, Red (2)	55	3-2243	ANCHOR
27	2-7429	CABLE, Rear Deck (25" Deck)	56	9-0233	SCREW, 5/16-24 x 3/4" Hex Head Cap, Grade 5 (2)
28	2-2112	RING, White (2) (25" Deck)	57	9-0391	WASHER, 5/16 Internal Tooth Lock (2)
29A	2-4762	BRACKET, Deck Lift (25" Deck Only!)	58	9-0223	NUT, 5/16-24 Hex (2)
29B	3-4695	BRACKET, Lift Assist (28", 30" & 33" Decks)	59	5-3923	ASSEMBLY, Clutch Plate

BLADE STOP PEDALS

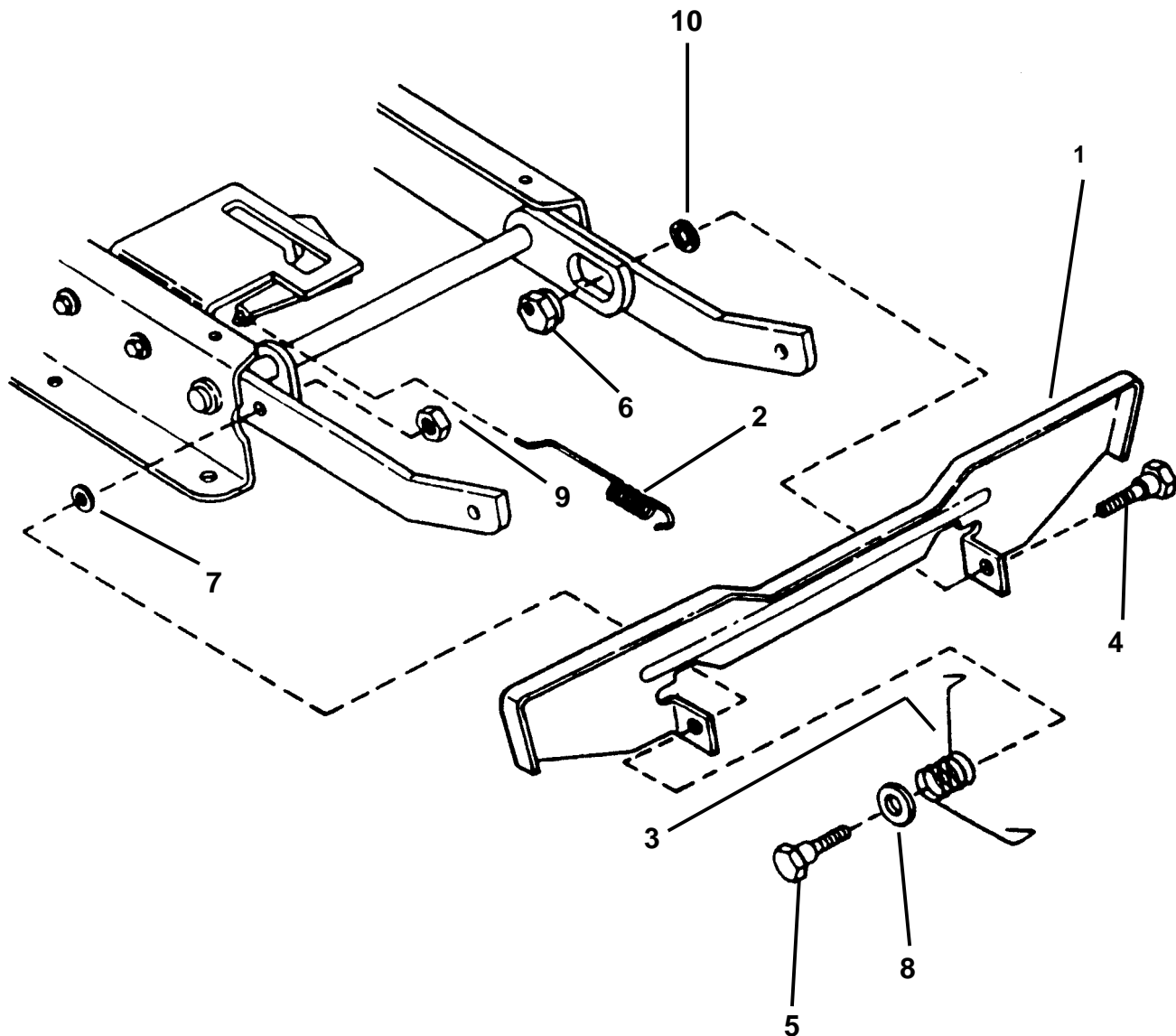

ITEM	PART NO.	DESCRIPTION
1	3-5970	PEDAL, Blade Stop Control
2	3-5669	SPRING, Latching
3	1-5448	SPRING, Pedal
4	1-5495	BOLT, 3/8-24 x 3/4" Shoulder
5	1-5446	BOLT, 3/8-24 x 9/16" Shoulder
6	1-5447	ECCENTRIC, Leveling
7	9-0122	WASHER, 3/8 Flat
8	9-0250	WASHER, 1/2 Flat (2)
9	9-0289	NUT, 3/8-24 Hex Center Lock
10	9-0390	WASHER, 3/8 Internal Tooth Lock

SPINDLE

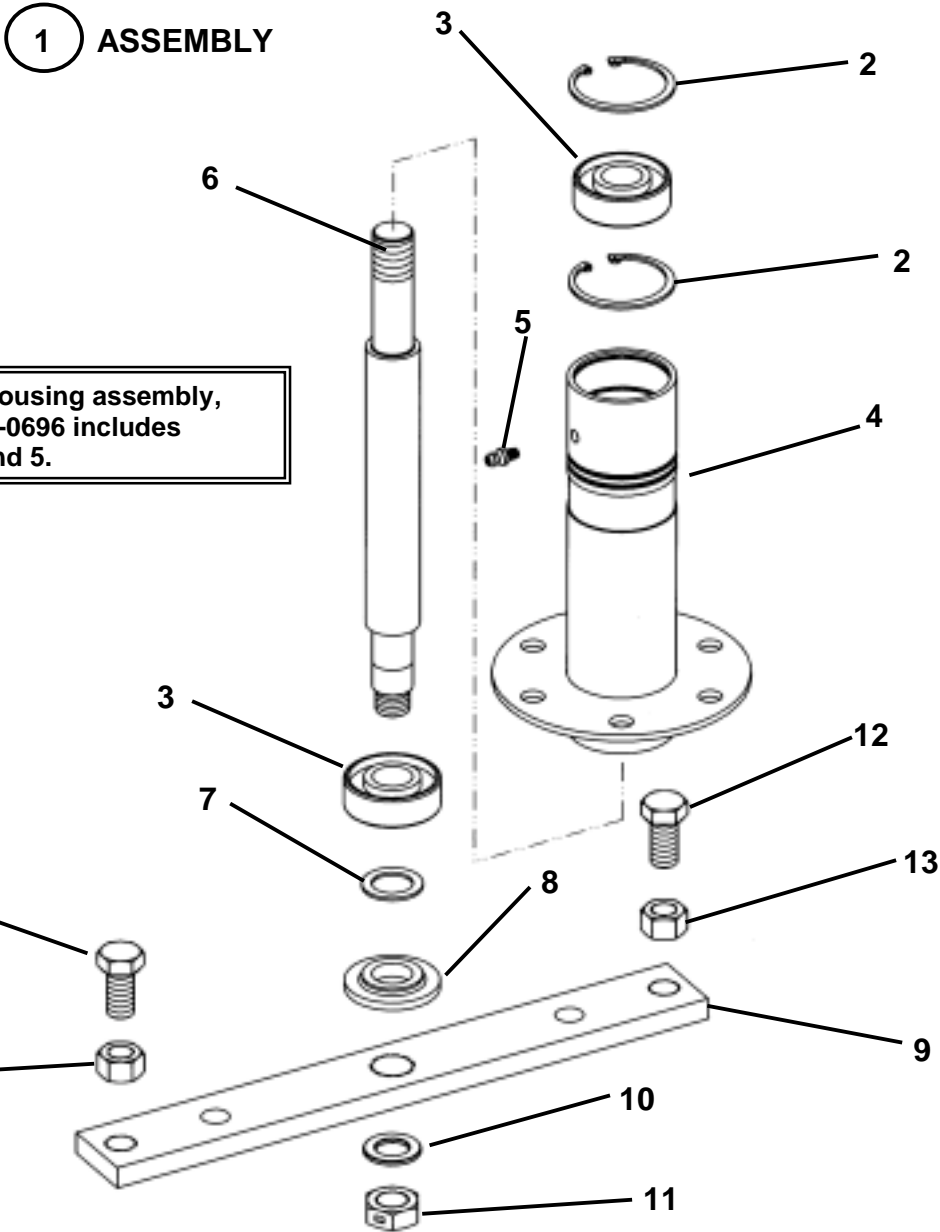

NOTE: Spindle housing assembly, Part no. 5-0696 includes Items 4 and 5.

ITEM	PART NO.	DESCRIPTION
1	5-4531	ASSEMBLY, Spindle Housing (Includes Items 2 Thru 13)
2	1-2491	RING, 1.85" Internal Retaining (2)
3	1-3313	BEARING, Spindle (2)
4	4-0460	WELDMENT, Spindle Housing
5	1-0817	FITTING, Lube (for 3/16" diameter Hole)
6	4-4785	SPINDLE, Rider (10.237" Overall Length)
7	1-0935	WASHER, 3/4 Shim
8	1-4407	WASHER, Spindle
9	3-7751	HOLDER, Blade
10	4-4782	SPACER, Blade Centering
11	9-0356	NUT, 5/8-18 Hex Center Lock
12	9-0491	SCREW, 1/2-20 x 1-1/4" Hex Head Cap, Grade 5 (2)
13	9-1939	NUT, 1/2-20 Hex Jam (2)

BELTS, BRAKES, INTERLOCK (25" MODELS) (Series 16)

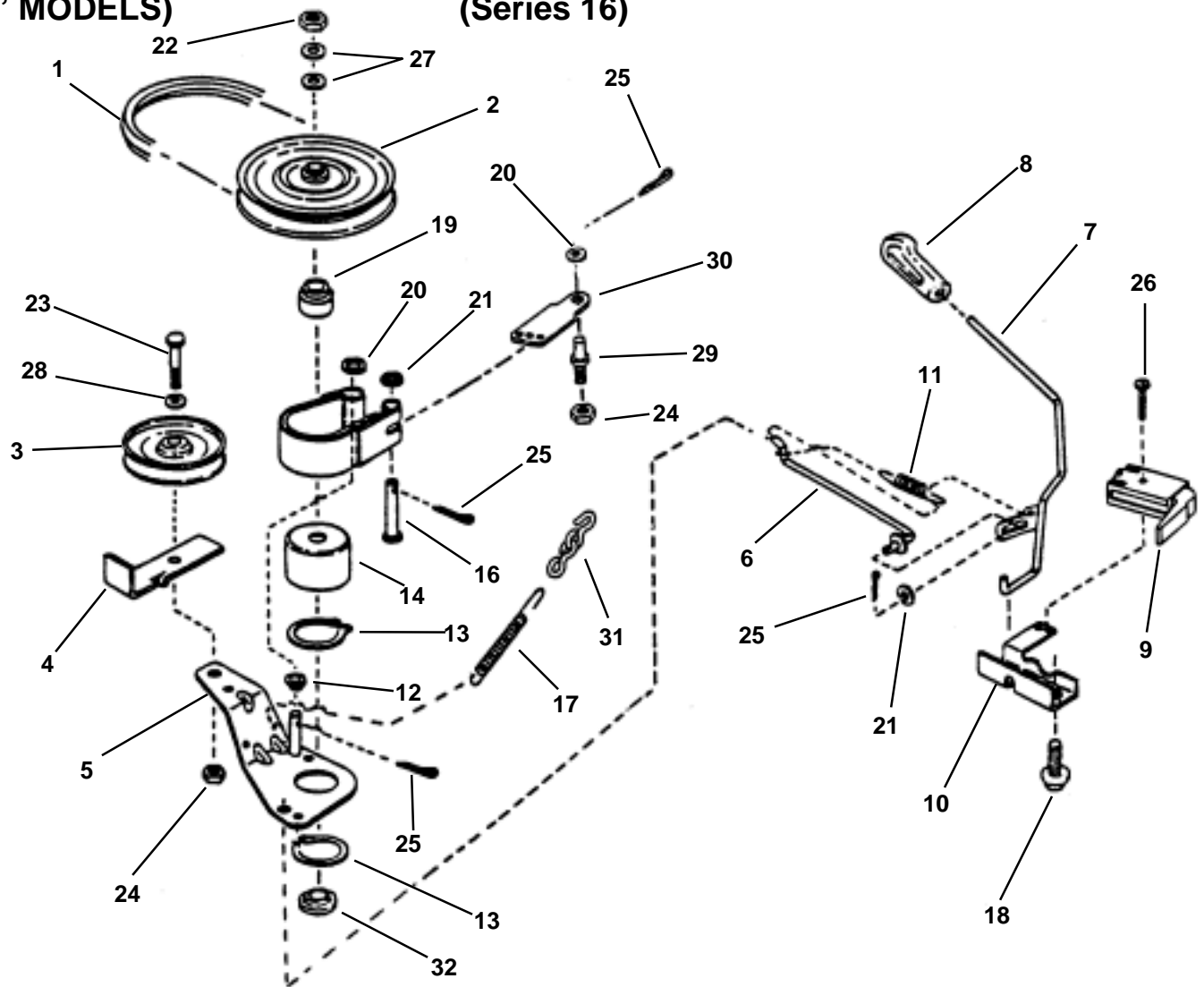

ITEM	PART NO.	DESCRIPTION	ITEM	PART NO.	DESCRIPTION
1	2-2252	BELT, Drive (72.25" AA Section)	17	2-3666	SPRING
2	1-8781	PULLEY, Spindle	18	9-0362	SCREW, 1/4-20 x 5/8"
3	2-9624	PULLEY, Idler			Hex Washer Self-Tap (2)
4	3-2111	RESTRICTOR, Belt	19	1-5290	HUB, Pulley
5	4-7787	ARM, Idler	20	9-0122	WASHER, 3/8 Flat (2)
6	1-2055	ROD, Idler	21	9-0055	WASHER, 1/4 Flat (2)
7	4-1324	HANDLE, Blade Lever (On-Off)	22	1-0027	NUT, 3/4-16 Hex Jam
8	2-3657	GRIP, Handle	23	9-1517	SCREW, 3/8-24 x 1-3/4" Hex Cap
9	1-8524	SWITCH, Deck Interlock	24	9-1518	NUT, 3/8-24 Hex Nyloc (2)
10	3-8021	MOUNT, Handle	25	9-0037	PIN, 3/32 x 3/4" Cotter (4)
11	1-4168	SPRING, Blade Handle	26	9-0299	SCREW, #10-32 x 1" Self-Tap
12	1-4314	SPACER	27	3-2027	WASHER, 49/64 x 1-1/2" Flat (2)
13	1-0740	RING, Retaining (2)	28	9-1514	WASHER, 3/8 Flat
14	3-5378	DRUM, Brake	29	1-5464	STUD (3/8-24 Thread)
15	3-4852	BAND, Brake	30	3-6400	BRACKET, Brake Anchor
16	1-4304	PIN, 1/4 x 1-5/8" Clevis	31	3-5563	LINK, Chain
			32	1-4407	WASHER, Spindle

BELTS, BRAKES, INTERLOCK (28" & 33" MODELS) (Series 16)

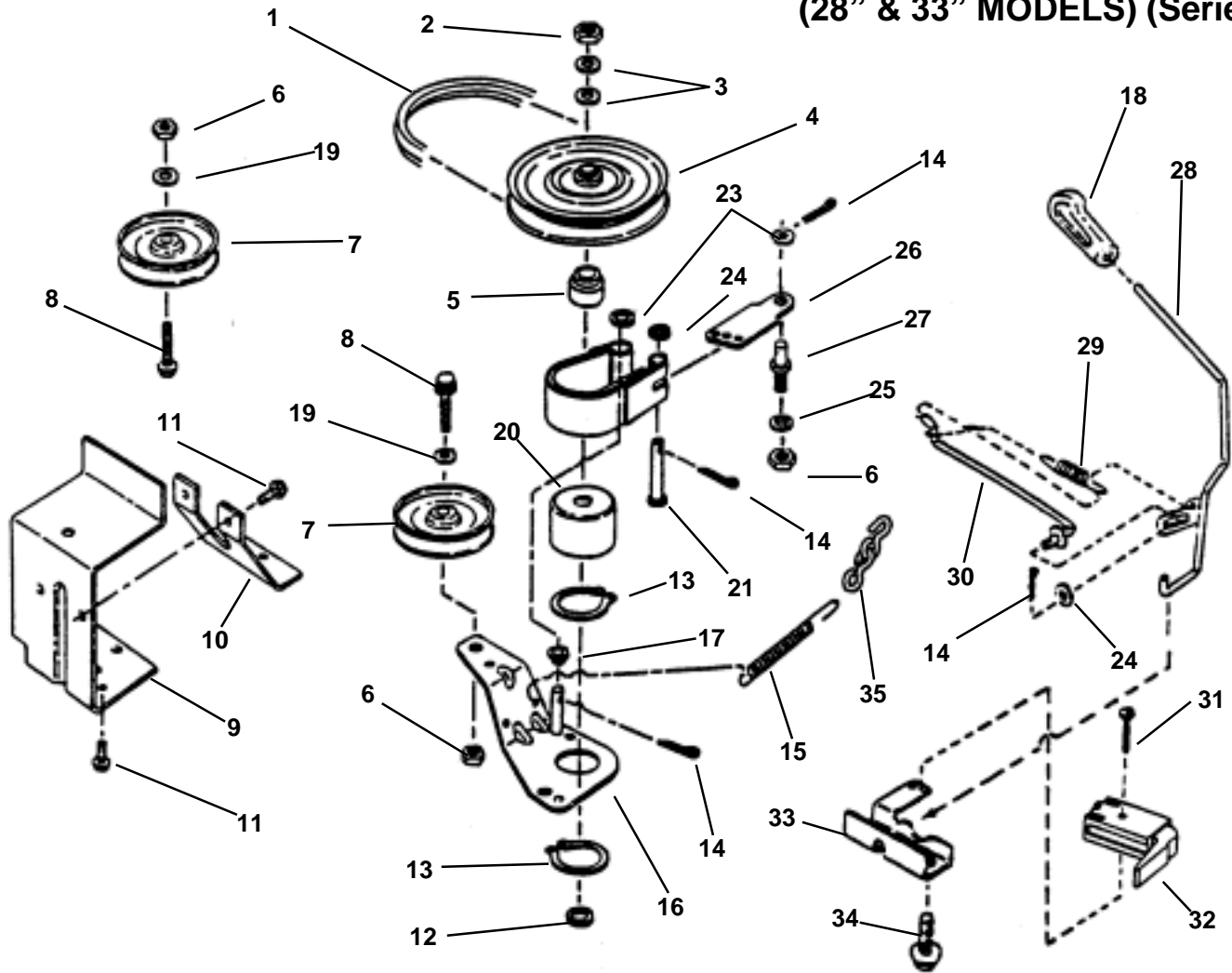

ITEM	PART NO.	DESCRIPTION
1	4-3844	BELT, Drive (73.75" AA Section)
2	1-0027	NUT, 3/4-16 Hex Jam
3	3-2027	WASHER, 49/64 x 1-1/2" Flat (2)
4	1-8781	PULLEY, Spindle
5	1-5290	HUB, Pulley
6	9-0155	NUT, 3/8-24 Hex (3)
7	2-9624	PULLEY, 4" Idler
8	9-1497	SCREW, 3/8-16 x 1-1/2" Hex Head Cap, Grade 5 (2)
9	3-5728	BRACKET, Fixed Idler
10	3-6526	BRACE
11	9-0858	SCREW, 5/16-18 x 1/2" Hex Washer Head, Self-Tapping (5)
12	1-4407	WASHER, Spindle
13	1-0740	RING, Retaining (2)
14	9-0037	PIN, 3/32 x 3/4" Cotter (3)
15	2-3666	SPRING
16	4-7787	ARM, Idler
17	1-4314	SPACER

ITEM	PART NO.	DESCRIPTION
18	2-3657	GRIP, Handle
19	9-1514	WASHER, 3/8 Flat (2)
20	3-5378	DRUM, Brake
21	1-4304	PIN, 1/4 x 1-5/8" Clevis
22	3-4852	BAND, Brake
23	9-0122	WASHER, 3/8" Flat (2)
24	9-0055	WASHER, 1/4" Flat (2)
25	9-0118	WASHER, 3/8" Split Lock
26	3-6400	BRACKET, Brake Anchor
27	1-5464	STUD (3/8-24 Thread)
28	4-1324	HANDLE, Blade Lever (ON-OFF)
29	1-4168	SPRING, Blade Handle
30	1-2055	ROD, Idler
31	9-0299	SCREW, #10-32 x 1" Hex Washer Self-Tap
32	1-8524	SWITCH, Deck Interlock
33	3-8021	MOUNT, Handle
34	9-0362	SCREW, 1/4-20 x 5/8" Hex Washer Self-Tap (2)
35	3-5563	LINK, Chain

**BELTS, BRAKES, INTERLOCK
(28" & 33" MODELS) (Series 18)**

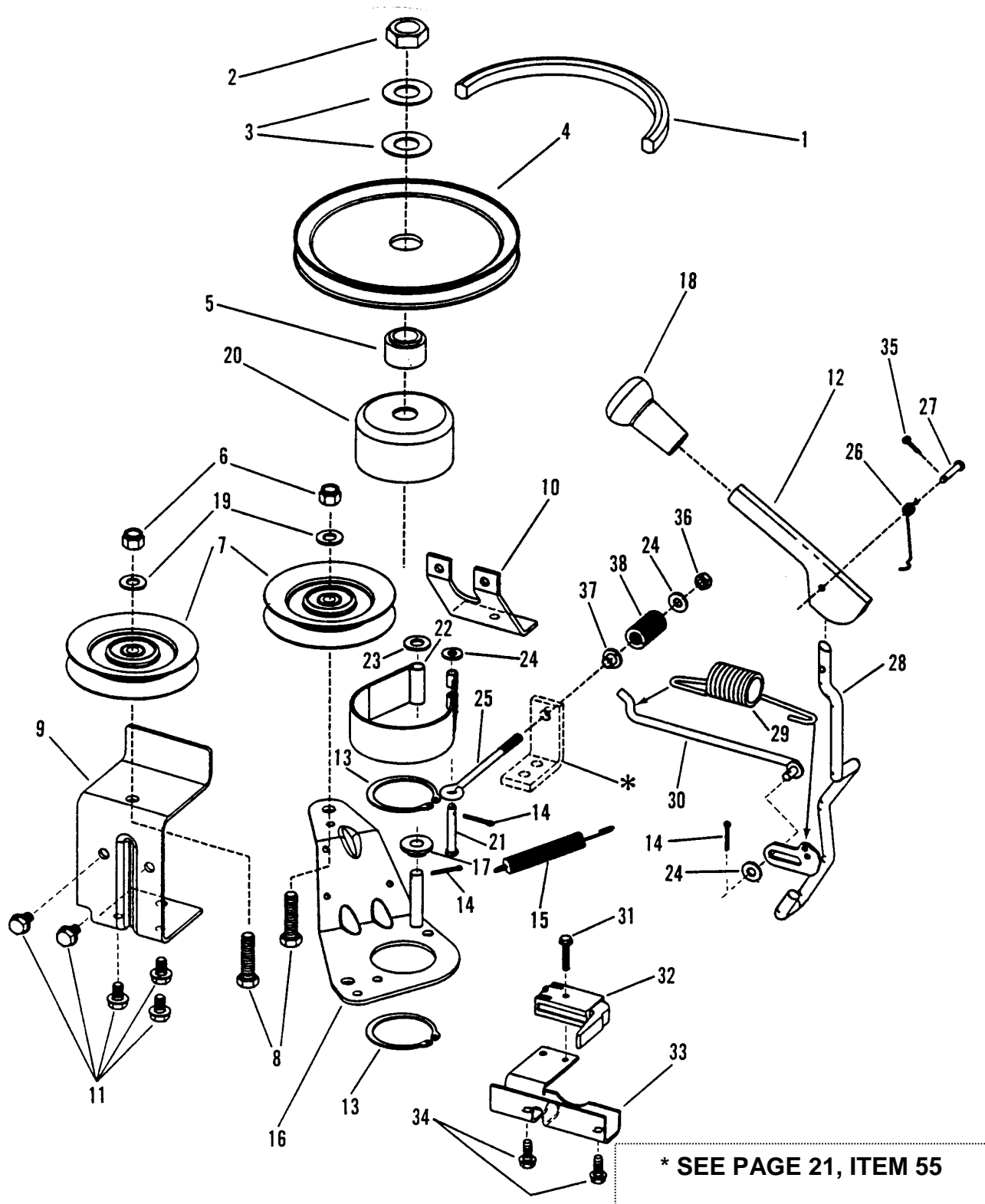

BELTS, BRAKES, INTERLOCK (28" & 33" MODELS) (Series 18)

ITEM	PART NO.	DESCRIPTION
1	4-3844	BELT, Drive (74.75" AA Section)
2	1-0027	NUT, 3/4-16 Hex Jam
3	3-2027	WASHER, 49/64" I.D. x 1-1/2" O.D. Flat (2)
4	1-8781	PULLEY, Spindle
5	1-5290	HUB, Pulley
6	9-1299	NUT, 3/8-16 Nyloc (2)
7	2-9624	PULLEY, 4" Idler (2)
8	9-1497	SCREW, 3/8-16 x 1-1/2" Hex Head Cap, Grade 5 (2)
9	3-5728	BRACKET, Fixed Idler
10	3-6526	BRACE, Fixed Idler
11	9-0858	SCREW, 5/16-18 x 1/2" Hex Washer Self-Tap (5)
12	4-6567	HANDLE, Blade Engage (Flip)
13	1-0740	RING, 2" External Retaining (2)
14	9-0037	PIN, 3/32 x 3/4" Cotter (3)
15	3-6521	SPRING, Extension, 4" x 1/2" Diameter
16	4-7787	WELDMENT, Idler Arm
17	1-4314	SPACER
18	4-6874	GRIP, Handle
19	9-1514	WASHER, 3/8" Flat (2)
20	3-5378	DRUM, Brake
21	1-4304	PIN, 1/4" x 1-5/8" Clevis
22	3-4852	BAND, Brake
23	9-0122	WASHER, 3/8" Flat (2)
24	9-0055	WASHER, 1/4" Flat (4)
25	4-6677	EYE-BOLT, 1/4-20 x 4"
26	4-6648	SPRING, Flip Handle
27	9-1974	PIN, 3/16 x 1" Clevis
28	4-6788	HANDLE, Blade Lever (ON-OFF)
29	1-4168	SPRING, Blade Handle
30	1-2055	ROD, Idler
31	9-0299	SCREW, #10-32 x 1" Hex Washer Self-Tap
32	1-8524	SWITCH, Deck Interlock
33	3-8021	MOUNT, Handle
34	9-0362	SCREW, 1/4-20 x 5/8" Hex Washer Self-Tap (2)
35	9-0555	PIN, 3/32 x 1/2" Cotter
36	9-0761	NUT, 1/4-20 Hex Top Lock
37	1-4343	BUSHING
38	4-6782	SPRING

DRIVE DISC ASSEMBLY

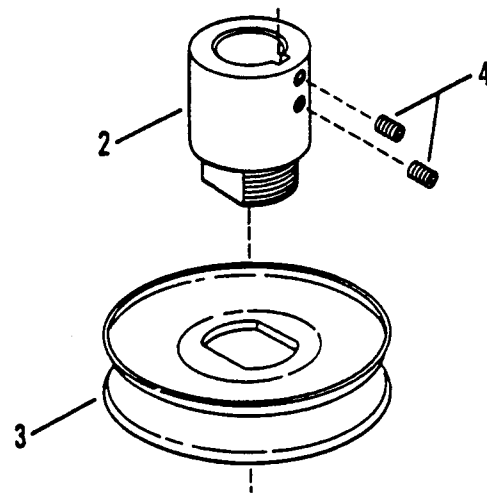
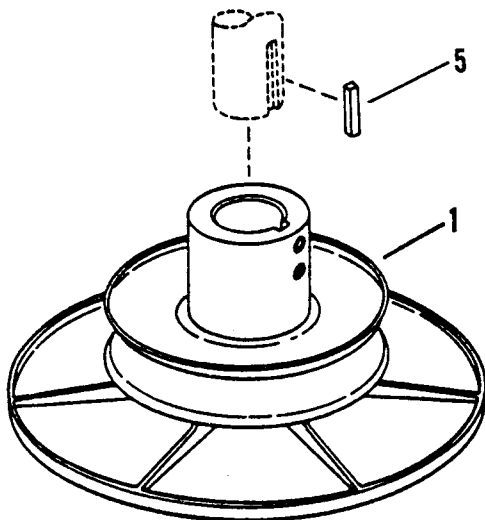

ITEM	PART NO.	DESCRIPTION
1	5-3708	ASSEMBLY, 5.18" O.D. Drive Disc (33" Models) (Includes Items 2 Thru 4)
1	5-3709	ASSEMBLY, 6" O.D. Drive Disc (25" & 28" Models) (Includes Items 2 Thru 4)
2	2-9112	HUB
3	2-8779	PULLEY, Drive (6.0" O.D.) (25" & 28" Models)
-	2-8796	PULLEY, Drive (5.18" O.D.) (33" Models)
4	9-0132	SET SCREW, 3/8-16 x 3/8" (2)
5	1-0210	KEY, 1/4" Square x 2"

FUEL TANK & OPERATORS SEAT

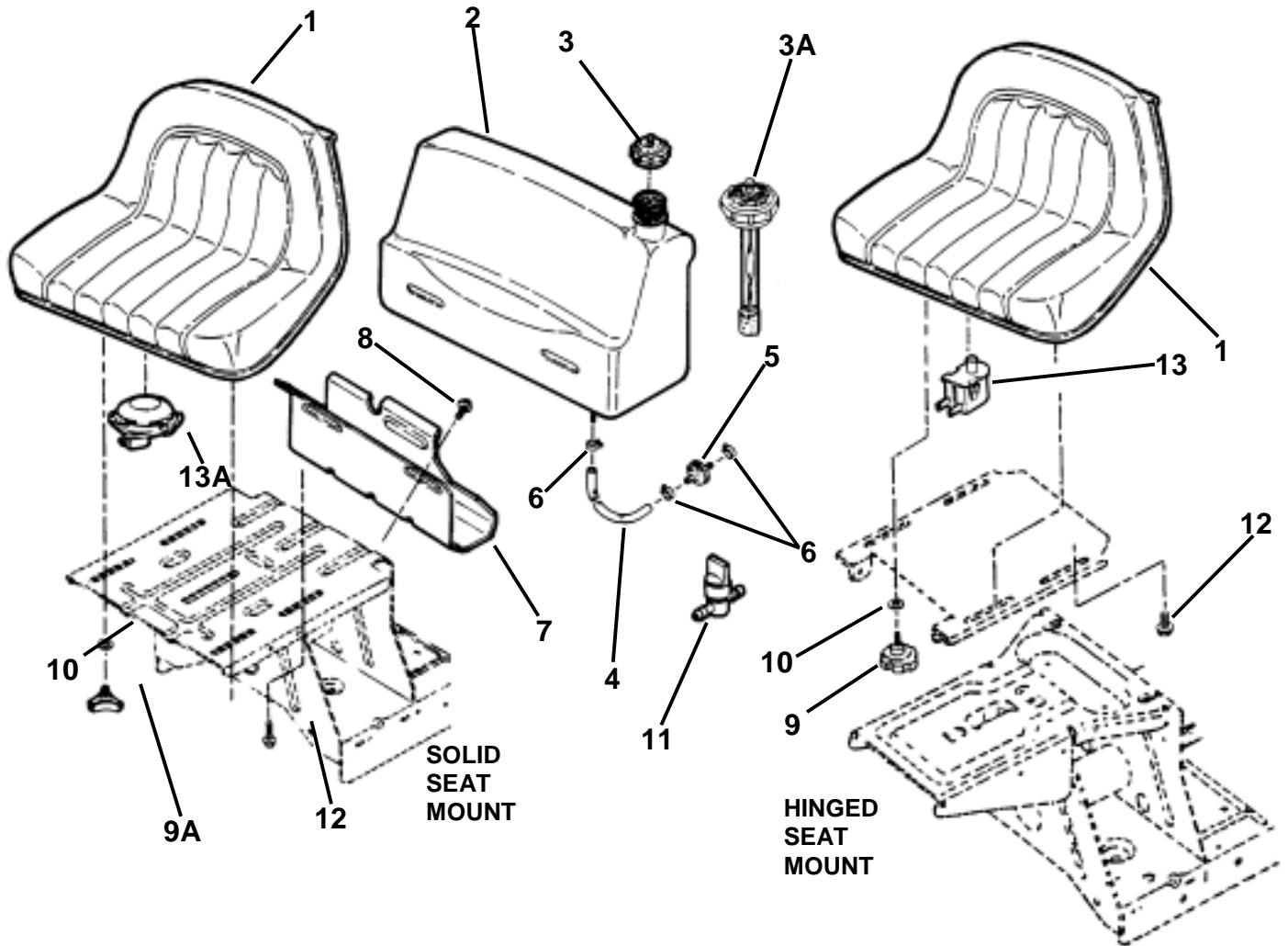

ITEM	PART NO.	DESCRIPTION
1	2-8595	SEAT, Operator
2	5-1905	ASSEMBLY, Fuel Tank (Includes Item 3) (25" & 28" Models)
--	5-2435	ASSEMBLY, Fuel Tank With Gauge (Includes Item 3A) (33" Models)
3	1-2515	CAP, Fuel Tank
3A	1-9377	CAP, Fuel Tank with Gauge
4	3-2015	HOSE, Fuel (7" Long)
--	3-2038	HOSE, Fuel (5" Long)
--	7-6272	HOSE, Fuel (8-1/2" Long) (Briggs Only)
--	1-2912	HOSE, Fuel (12-1/2" Long) (Kohler Only)
5	1-4359	FILTER, Fuel (In-Line)
6	1-2222	CLAMP, Fuel Line (4)
7	3-3377	BRACKET, Fuel Tank (Rear)
8	9-1542	SCREW, 5/16-18 x 5/8" Pan Head Torx Self-Tap (2)
9	2-8659	KNOB (2), Hinged Seat (Series 16 & 18)
9A	2-3191	KNOB, Seat Adjusting (2)
10	1-3849	SPACER, 5/16 (33" Models) (2)
11	2-4507	VALVE, Fuel Shut-Off (Accessory)
12	9-1038	BOLT, 5/16-18 x 1/2" Hex Flange Lock (2)
13	2-3354	SWITCH, Seat
13A	2-9211	SWITCH, Seat

ENGINES & EXHAUST MUFFLER

ENGINE. H.P.	START TYPE	ENGINE MFGR.	MFGR. MODEL	MFGR. TYPE
8.0	ELECTRIC	BRIGGS & STRATTON	195707	0143-01
10.0	ELECTRIC	BRIGGS & STRATTON	28A207	0121-01
13.0	ELECTRIC	BRIGGS & STRATTON	28M707	0113-01
13.0	ELECTRIC	BRIGGS & STRATTON	28M707	1166-E1
14.0	ELECTRIC	KOHLER	CV14ST	PS-1473
15.0	ELECTRIC	KOHLER	CV15ST	PS-41584

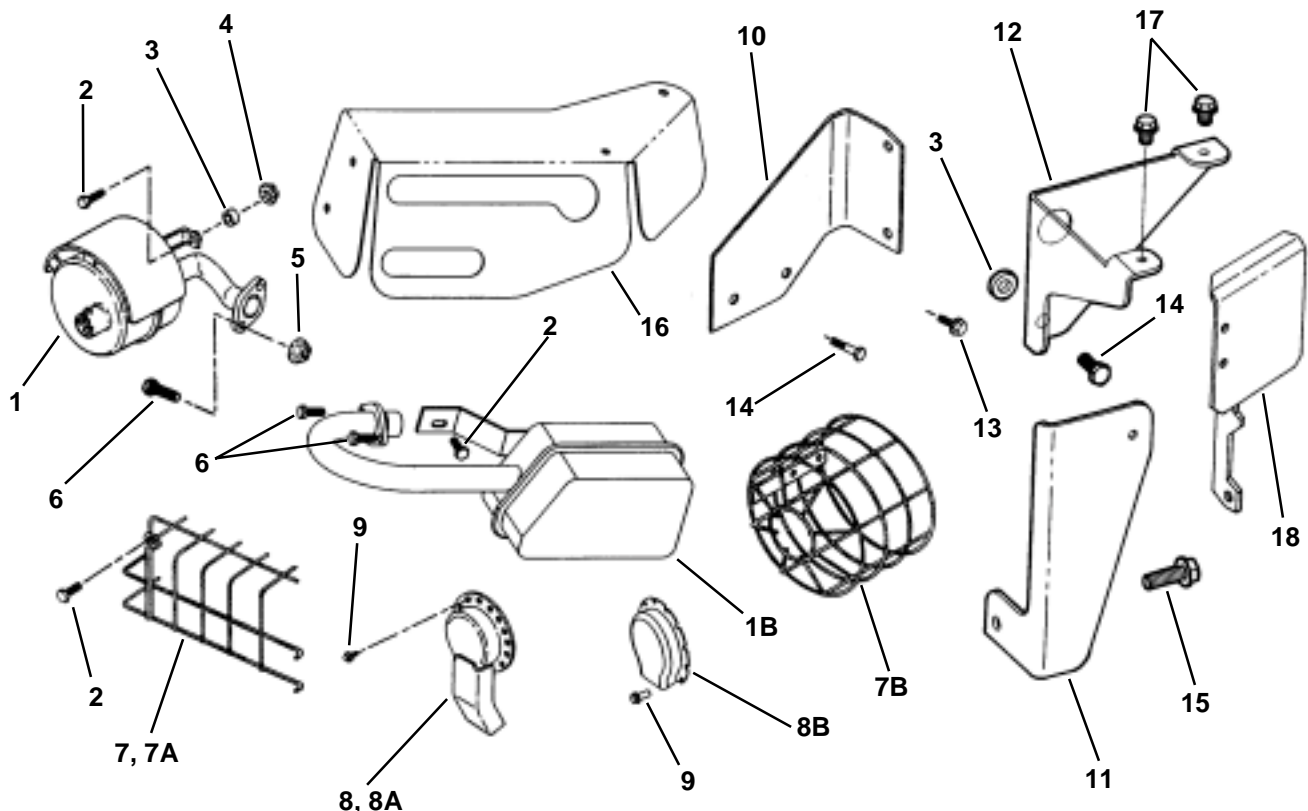

ITEM	PART NO.	DESCRIPTION	ITEM	PART NO.	DESCRIPTION
1	1-9358**	MUFFLER	8	4-1367*	DEFLECTOR, Heat(10/12)
1A	4-1824*	MUFFLER, Lo-Tone (not shown)	8A*	4-1368*	DEFLECTOR, Heat (8 HP)
1B	2-8358*	MUFFLER, 8 HP Briggs	8B	5-8585*	DEFLECTOR, Heat (8 HP)
1C	5-1996*	MUFFLER, 10, 12, & 13 HP Briggs (not shown)	9	9-1581*	SCREW, #8-18x1/2"Self-Tap (3)
2	9-1495**	SCREW, 1/4-20 x 3/4" Hex Head Cap, Grade 5	10	3-3564**	BRACKET, Muffler Guard
3	1-3849**	SPACER (Series 18)	11	5-8580*	BRACKET, Heat Shield (Series 18)
4	9-1065**	NUT, 1/4-20 Hex Fl. Lock	12	5-8579*	BRACKET, Heat Shield (Series 18)
5	9-1070**	NUT, 5/16-18 Hex Flange Lock, Grade 5 (2)	13	9-1016**	SCREW, 1/4-20 x 5/8" Hex Head, Self-Tap (2)
6	9-0206**	SCREW, 5/16-18 x 3/4" Hex Head Cap, Grade 2 (2)	14	9-1059*	SCREW, 1/4-20 x 1" Hex Hd Cap, Grade 5
7	2-4092*	GUARD, Muffler (10/12HP)	15	9-0369*	SCREW, 5/16-18 x 1" Hex Washer Self-Tap
7A	2-4441*	GUARD, Muffler	16	5-8578*	SHIELD, Heat (Series 18)
7B	2-4356**	GUARD, Muffler	17	9-1293*	SCREW, 1/4-20 x 3/8" Hex Washer Self-Tap (3)
			18	4-1644*	SHIELD, Heat

*Used on Briggs

**Used on Kohler

THROTTLE CONTROL

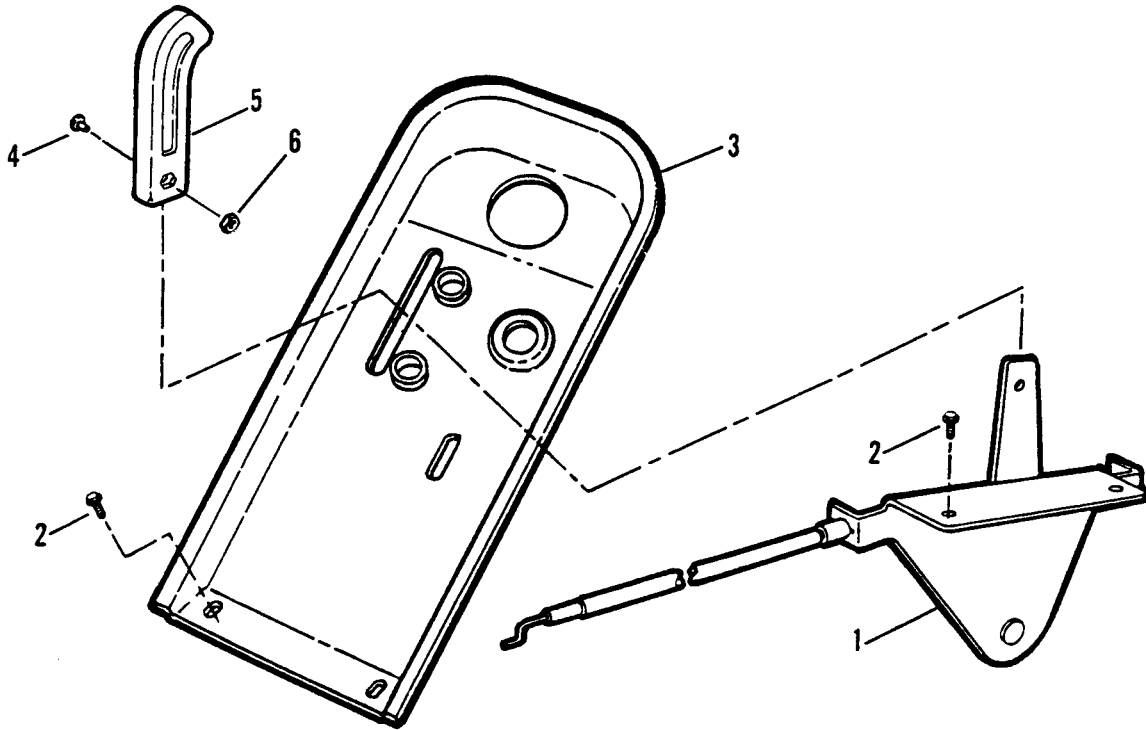

ITEM	PART NO.	DESCRIPTION
1	2-4155	CONTROL, Throttle (Briggs Engines)
--	2-2483	CONTROL, Throttle (Kohler Engine)
2	9-0913	SCREW, #10-24 x 1/2" Hex Washer Self-Tap (Torx) (5)
3	2-3665	COVER, Dash Panel (Electric Start)
4	9-1017	SCREW, #8-32 x 3/8" Cross Recessed Fillister Head (2)
5	2-3655	KNOB, Throttle Control
6	9-1018	NUT, #8-32 Hex, Grade 2 or B

ELECTRICAL SYSTEMS (For 8, 10, 12 & 13 HP Briggs)

ITEM	PART NO.	DESCRIPTION
1	6-0753	KIT, 12Volt Dry Charge Battery
2	1-8817	SOLENOID
3	2-2788	HARNESS, Starter Wiring (Briggs Engines)
4	1-9297	HARNESS, Ignition Wiring (Briggs Engines)
5	1-6168	HOLDER, Fuse (Includes Fuse)
--	1-6169	FUSE (10 AMP)
6	2-8606	INTERLOCK Module (Briggs)
7	2-8386	HARNESS (Deck Interlock Wiring)
8	1-8524	SWITCH, Deck Interlock (NO)
9	1-2444	COVER, Battery Cable
10	1-9326	CABLE, Positive (17" Long, Red)
11	1-8816	SWITCH, Ignition (Used With Electric Start)
12	9-0880	WASHER, 5/8 Internal Tooth Lock
13	1-5438	NUT, 5/8-32 Hex
14	1-1138	KEY, Switch (2)
15	9-0539	SCREW, 1/4-20 x 1/2" Hex Washer Self-Tap (3)
16	2-2887	PROTECTOR (25" Models Only!)
17	9-1576	NUT, 1/4-20 Hex, Grade 5 or B (5)
18	9-0053	WASHER, 1/4 Internal Tooth Lock (2)
19	2-7172	SCREW, 1/4-20 x 5/8" Hex Head Cap, Grade 5 (2)
20	2-8027	CABLE, Negative (15" Long)
21	2-8607	HARNESS, Operator Presence Control (OPC) Wire
22	1-7590	SWITCH, Seat (12 & 13H.P. Briggs) (NC)
23	1-2080	TIE, 7" Long Cable (2)
24	9-0372	NUT, 1/4-20 Hex Center Lock (2)
25	1-4451	TIE, 2" Long Cable
26	2-9211	SWITCH, Seat (8 HP & 10 HP Engines) (NC)
27	2-2886	SWITCH, Operator Presence Control (OPC) Traction (NC/NO)
28	1-2485	RETAINER, 1/4" Bolt (2)

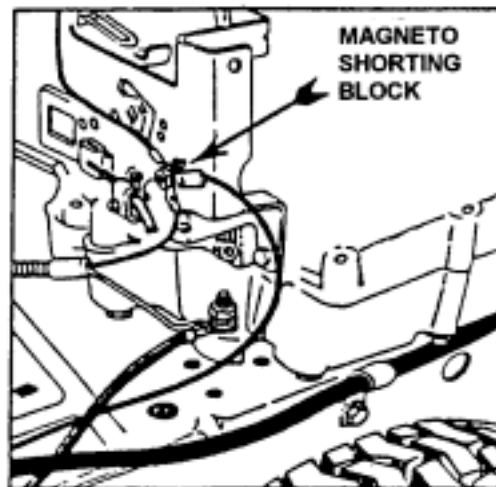

ELECTRICAL SYSTEMS (For 14 & 15 HP KOHLER)

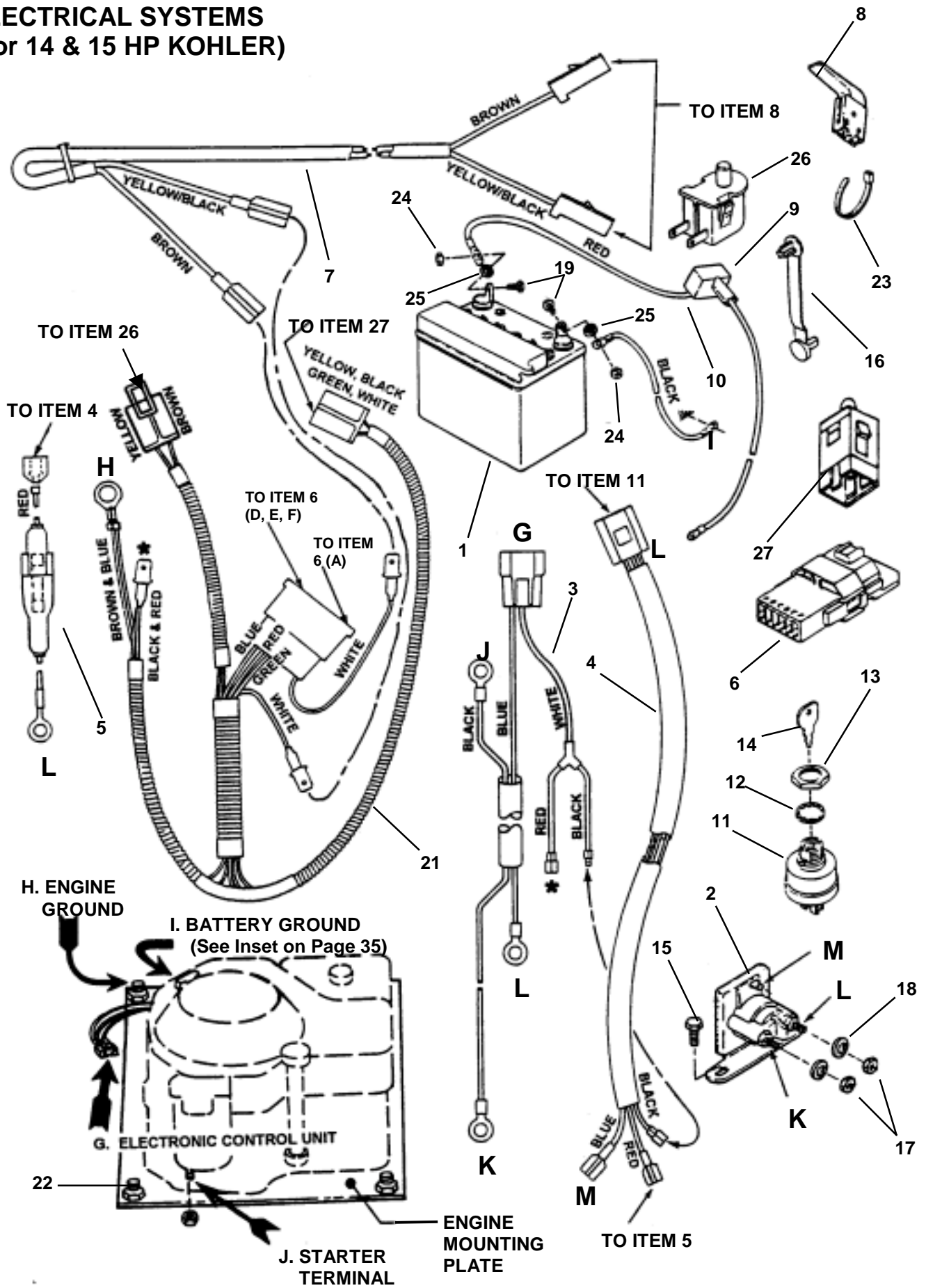

ELECTRICAL SYSTEMS (For 14 & 15 HP KOHLER)

ITEM	PART NO.	DESCRIPTION
1	6-0753	KIT, 12V Dry Charge Battery
2	1-8817	SOLENOID
3	1-9321	HARNESS, Starter Wiring (Kohler)
4	1-9322	HARNESS, Ignition Wiring (Kohler)
5	1-6168	HOLDER, Fuse (Includes Fuse)
	1-6169	FUSE (10 AMP)
6	2-8606	INTERLOCK Module (Briggs & Kohler)
7	2-8386	HARNESS, (Deck Interlock Wiring)
8	1-8524	SWITCH, Deck Interlock (NO)
9	1-2444	COVER, Battery Cable
10	1-9326	CABLE, Positive (Red) (17" Long)
11	1-8816	SWITCH, Ignition
12	9-0880	WASHER, 5/8 Internal Tooth Lock
13	1-5438	NUT, 5/8-32 Hex
14	1-1138	KEY, Switch (2)
15	9-0539	SCREW, 1/4-20 x 1/2" Hex Washer Self-Tap (3)
16	1-4451	TIE, 2" Long Cable
17	9-0063	NUT, 1/4-20 Hex (4)
18	9-0053	WASHER, 1/4 Internal Tooth Lock (2)
19	2-7172	SCREW, 1/4-20 x 5/8" Hex Head Cap, Grade 5 (2)
20	2-8027	CABLE, Negative (15" Long)
21	2-8678	HARNESS, Operator Presence Control Wire
22	9-1576	NUT, 1/4-20 Hex, Grade 5 or B
23	1-2080	TIE, 7" Long Cable (2)
24	9-0372	NUT, 1/4-20 Hex Center Lock (2)
25	1-2485	RETAINER, 1/4 Bolt (2)
26	1-7590	SWITCH, Seat (NC)
27	2-2886	SWITCH, Operator Presence Control (OPC) Traction (NC/NO)

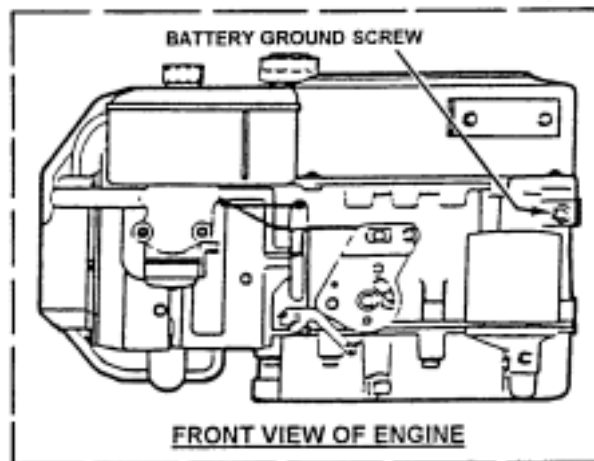

WIRING SCHEMATICS

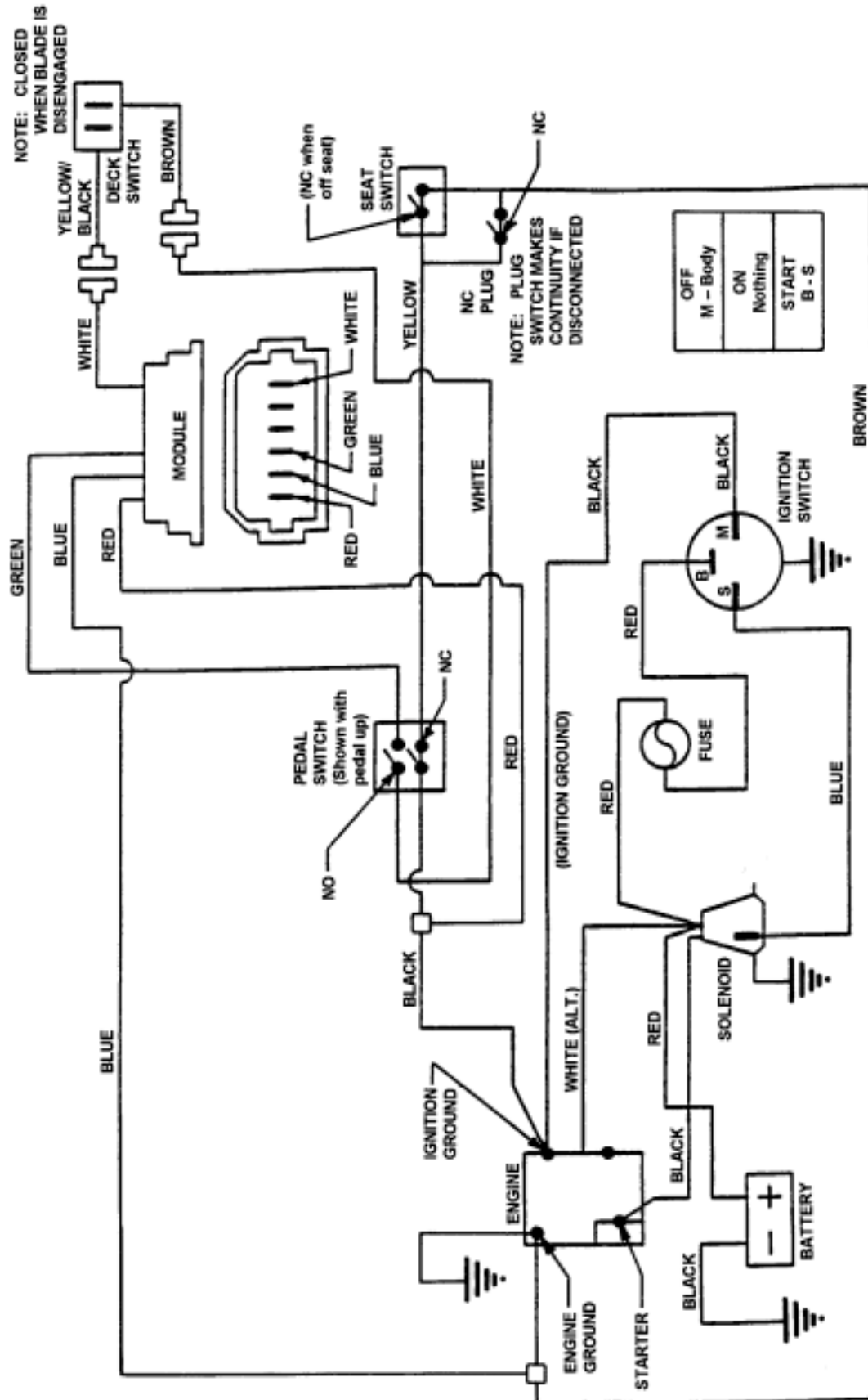

WIRING SCHEMATIC FOR 8, 10, 12 & 13 HP BRIGGS ENGINES

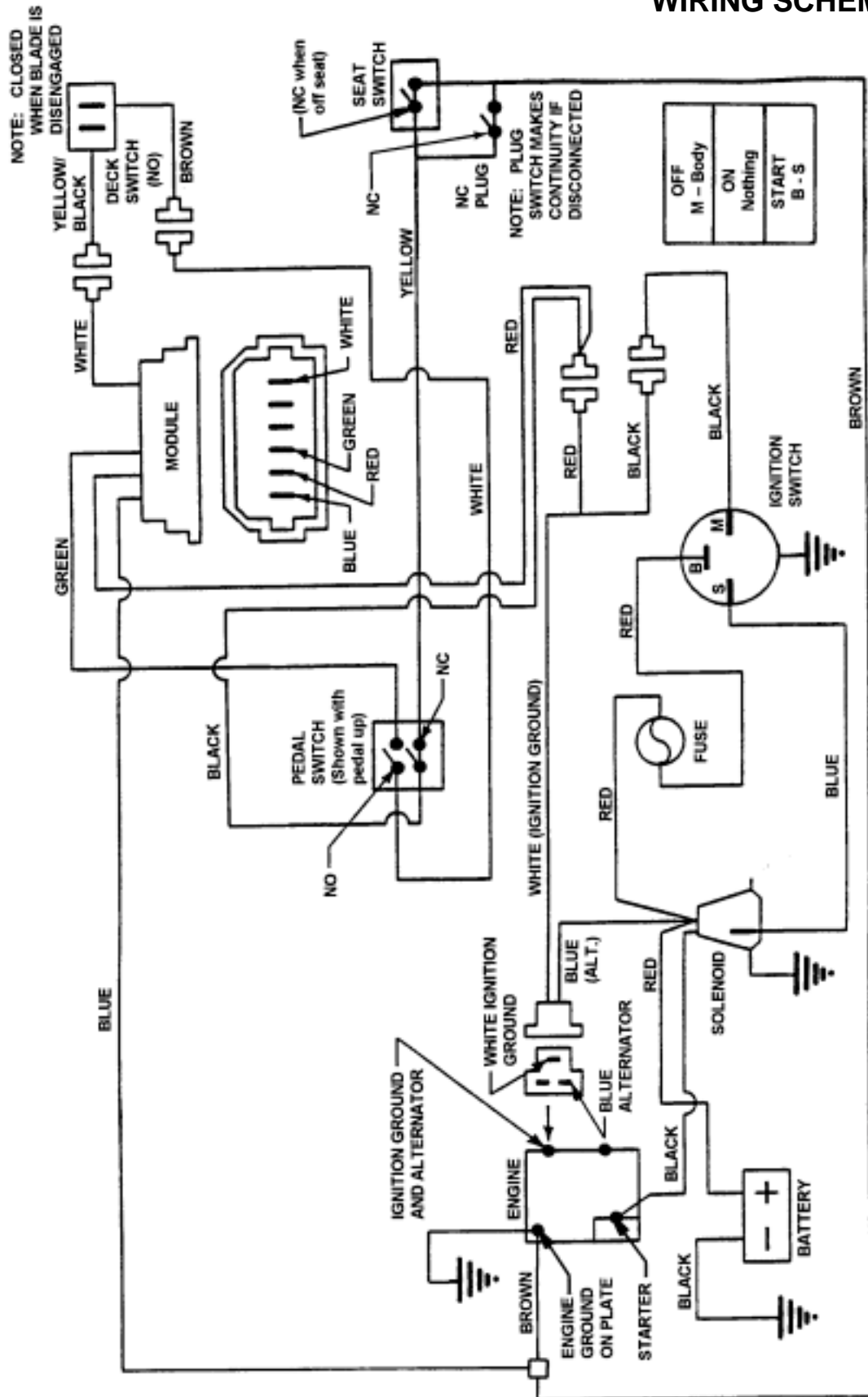

WIRING SCHEMATIC FOR 14 & 15 HP KOHLER ENGINES

DECALS

EUROPEAN DECALS

BREMSBETRIEB

ANHALTEN: KLUPPLINGS/BREMSPEDAL TRETEN.

ANZIEHEN DER PARKBREMSE: KLUPPLINGS/BREMSPEDAL TRETEN, PARKBREMSZUGHÄNGEL HOCHZIEHEN UND KLUPPLINGS/BREMSPEDAL LOSLASSEN.

ZUM LOSLASSEN DER PARKBREMSE: KLUPPLINGS/BREMSPEDAL TRETEN.

BETRIEB DES MESSERS

EINSCHALTEN DES MESSERS: MESSERHEBEL AUF „ON“ BZW. EIN UND „HOLD“ (FESTHALTEN), MESSERPEDAL MIT DEM ABSATZ TRETEN. ZUM MAÄHN ABSATZ AUF DEM MESSERPEDAL LASSEN.

AUSSCHALTEN DES MESSERS: ABSATZ WEG VOM MESSERPEDAL ODER MESSERHEBEL AUF „OFF“ BZW. AUS.

FONCTIONNEMENT DES FREINS

POUR L'ARRÊT: APPUYEZ SUR LA PÉDALE ENBRAYAGE/FREIN.

POUR METTRE LES FREINS DE STATIONNEMENT: APPUYEZ SUR LA PÉDALE ENBRAYAGE/FREIN. SOULEVEZ LE LOQUET DU FREIN DE STATIONNEMENT ET RELACHEZ LES PÉDALES ENBRAYAGE/FREIN.

POUR RELÂCHER LES FREINS DE STATIONNEMENT: APPUYEZ SUR LA PÉDALE ENBRAYAGE/FREIN.

FONCTIONNEMENT DE LA LAME

POUR ACTIONNER LA LAME: DÉPLACER LE LEVIER EN LE MAINTENANT, APPUYEZ AVEC LE TALON, MAINTENEZ UN DE VOS TALONS SUR LA PÉDALE POUR TONDER.

POUR ARRÊTER LA LAME: RETIRER VOTRE TALON DE LA PÉDALE OU PLACER LE LEVIER SUR OFF.

REMBEDIENING

OM TE STOPPEN: DUW ONTKOPPELJNG/REMPEDAAL IN.

OM PARKEERREM AAN TE ZETTEN: DUW ONTKOPPELJNG/REMPEDAAL IN, HEF PARKEERHEFBOOM OP EN LAAT ONTKOPPELINGSREMPEDAAL LOS.

OM PARKEERREM LOS TE LATEN: DUW ONTKOPPELJNG/REMPEDAAL IN.

MESBEDIENING

OM HET MES TE STARTEN: TREK MESHEFBOOM NAAR "ON" EN HOUD VAST. DUW OP MESPEDAAL MET HIEL. HOUD HIEL OP MESPEDAAL OM TE MAAIEN.

OM HET MES TE STOPPEN: VERWIJDER HIEL VAN MESPEDAAL EN VERPLAATS MESHEFBOOM NAAR "OFF".

AVERTISSEMENT WARNING

BEWAAR U TOEGEHOORIGHEID BIJ ONGLUKSVAL

FOR UNFALLERHITUNG

LE DEFLECTEUR LATÉRAL OU LE BAC DE RAMASSAGE DOIVENT ÊTRE INSTALLÉS AVANT L'UTILISATION DE LA TONDEUSE.

VOR INMETRENAHME DES MAHERS SIND AUSWURFBLECH BZW. GRASFANGVORRICHTUNG ZU BEFESTIGEN.

3 LWA

100

ATTENTION VORSICHT

LE DEFLECTEUR LATÉRAL OU LE BAC DE RAMASSAGE DOIVENT ÊTRE INSTALLÉS AVANT L'UTILISATION DE LA TONDEUSE.

VOR INMETRENAHME DES MAHERS SIND AUSWURFBLECH BZW. GRASFANGVORRICHTUNG ZU BEFESTIGEN.

CE

29776

REMOVE BATTERY BEFORE STANDING MOWER ON END FOR MORE THAN 2 HOURS

ENTFERNEN SIE DIE BATERIE, BEVOR SIE DEN REITERMÄHER FÜR MEHR ALS 2 STUNDEN STELLEN.

LA BATTERIE DOIT ÊTRE ENLEVÉE AVANT DE METTRE LA TONDEUSE DÉBOÛT POUR PLUS DE 2 HEURES

BATTERY VERWIJDEREN INDIEN U DE MAAIER VOOR MEER DAN 2 UUR RECHT OP ZET

ITEM	PART NO.	DESCRIPTION
1	2-2215	DECAL, Brake Operation (German)
2	2-2216	DECAL, Brake Operation (French)
3	2-2218	DECAL, Brake Operation (Dutch)
4	2-2841	DECAL, WARNING
5	2-3009	DECAL, European Noise Control
6	3-5973	DECAL, SAFETY Instruction (German & French)
7	2-9776	DECAL, European Community
8	2-4052	DECAL, Deflector (German & French)
9	2-9948	DECAL, Battery Storage

DECALS (Continued On Next Page)

DECALS

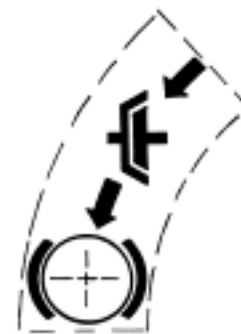
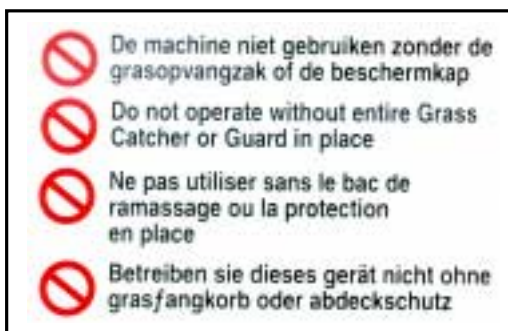

ITEM	PART NO.	DESCRIPTION
10	3-5974	DECAL, SAFETY Instruction (English & Dutch)
11	2-9784	DECAL, DO NOT OPERATE!
12	2-8514	DECAL, Clutch/Brake
13	2-9947	DECAL, Battery CAUTION
14	2-4072	DECAL, Automatic Blade Stop
15	2-3992	DECAL, 25 Inch (Hi-Vac)
16	2-9839	DECAL, Deflector CAUTION (English & Dutch)
17	2-3996	DECAL, 28 Inch (Hi-Vac)
18	2-2991	DECAL, 33 Inch (Hi-Vac)

DECALS

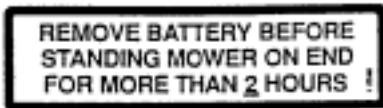
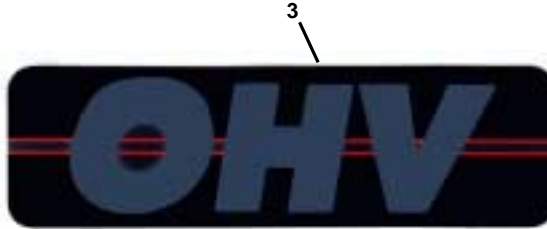

ITEM	PART NO.	DESCRIPTION
1	1-6974	DECAL, SNAPPER (Molded Logo)
2	2-3980	DECAL, Back-Up Recoil (33" Kohler Engine Models)
3	2-3982	DECAL, OHV (33" Kohler Engine Models)
4	3-4134	LOGO, Convertible (Silver)
--	2-4068	LOGO, Convertible (Teal)
--	2-4067	LOGO, Convertible (Blue)
--	7-1926	LOGO, Convertible (Blue)
5	2-6419	DECAL, Height Of Cut
6	2-9453	MEDALLION, "Sam"
7	1-2358	DECAL, Battery
8	2-3983	DECAL, 14 HP (33" Kohler Engine Models)
9	2-4072	DECAL, Automatic Blade Stop (Point Of Purchase Decal)
*	2-9077	DECAL, Year Of Manufacture (1996)
*	2-3998	DECAL, Bumper Stripe (Teal)
*	3-6434	DECAL, Year Of Manufacture (1997)
*	7-2404	DECAL, Year Of Manufacture (1999)
*	7-2820	DECAL, Year Of Manufacture (2000)

***NOTE:** These Items Not Shown; The Description Is the Visual Identification.

DECALS (Continued On Next Page)

DECALS

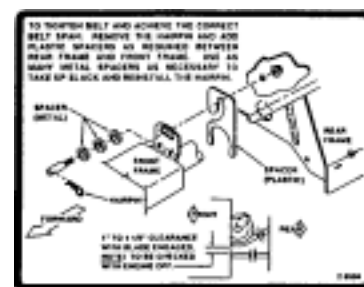
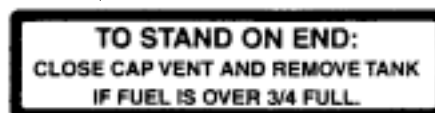
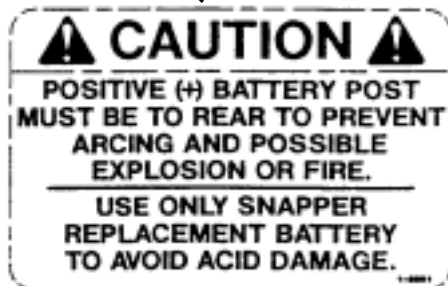
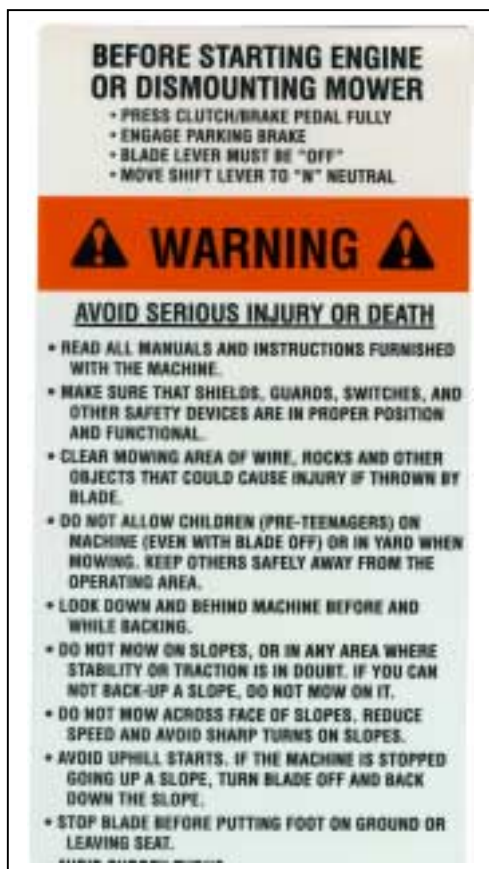

ITEM	PART NO.	DESCRIPTION	ITEM	PART NO.	DESCRIPTION
10	4-6440	DECAL, Safety Instruction Warning	*	2-4042	DECAL, Banner Stripe (Silver)
11	1-6972	DECAL, CAUTION, Deflector	*	2-4045	DECAL, Banner Stripe (Blue)
12	1-6973	DECAL, CAUTION, Rotating Blades	*	4-6703	DECAL, Banner Stripe (Blue)
13	1-5691	DECAL, CAUTION, Battery	*	2-4001	DECAL, Bumper Stripe (Silver)
14	1-3010	DECAL, DANGER	*	2-4004	DECAL, Bumper Stripe (Blue)
15	2-9113	DECAL, CAUTION, Fuel	*	4-6704	DECAL, Bumper Stripe Narrow (Blue)
16	2-9594	DECAL, Belt Adjustment (Used On 25" Models)	*	2-4043	DECAL, Banner Stripe (Teal)
17	2-9114	DECAL, CAUTION, Fuel Leakage (Dutch)	*	2-3998	DECAL, Bumper Stripe (Teal)
18	2-9346	DECAL, CAUTION, Fuel Leakage (German)			
19	2-9345	DECAL, CAUTION, Fuel Leakage (French)			

***NOTE:** These Items Not Shown; The Description Is the Visual Identification.

ACCESSORIES & ATTACHMENTS

SNAPPER REAR ENGINE RIDER ACCESSORIES*

PART NO.	DESCRIPTION OF KIT	MODELS USED ON
6-0517	Wheel Weight (8" Wheels)	All Rear Engine Riders
6-0697	Dump Cart	All Rear Engine Riders
6-0737	Gauge Wheel	All 33" Deck Rear Engine Riders
6-0941	Single Bag Catcher	All 25" Deck Rear Engine Riders
6-0943	Single Bag Catcher	All 28" & 33" Deck Rear Engine Riders
6-0946	Twin Bag Catcher	All 28" & 33" Deck Rear Engine Riders
6-0947	Bag-N-Wagon	All 28" & 33" Deck Rear Engine Riders
6-0948	Thatcherizer	All Series 7 & Newer Riders
6-0964	Wagon Cover	All 28" & 33" Deck Rear Engine Riders
6-1190	Weight (Front)	All Series 7 & Newer Riders
6-0959	Dozer Blade (36" Blade)	All Rear Engine Riders
6-0357	Tire Chains (Tires-16 x 6.50-8)	All Rear Engine Riders
6-0357	Tire Chains (Tires-16 x 4.80-8)	All Rear Engine Riders
6-1049	Ninja Recycling (Cover)	All 25" Deck Rear Engine Riders
6-1253	Ninja Recycling (Cover)	All 28" Deck Rear Engine Riders
6-1255	Ninja Recycling (Cover)	All 33" Deck Rear Engine Riders
6-0325	Drive Disc Puller	All RER Aluminum Drive Discs

***For illustrated parts lists see manual #0-6084.**

HARDWARE BAGS

HARDWARE BAG 6-1792 (Used on Models: E331416KVE & E331518KVE)

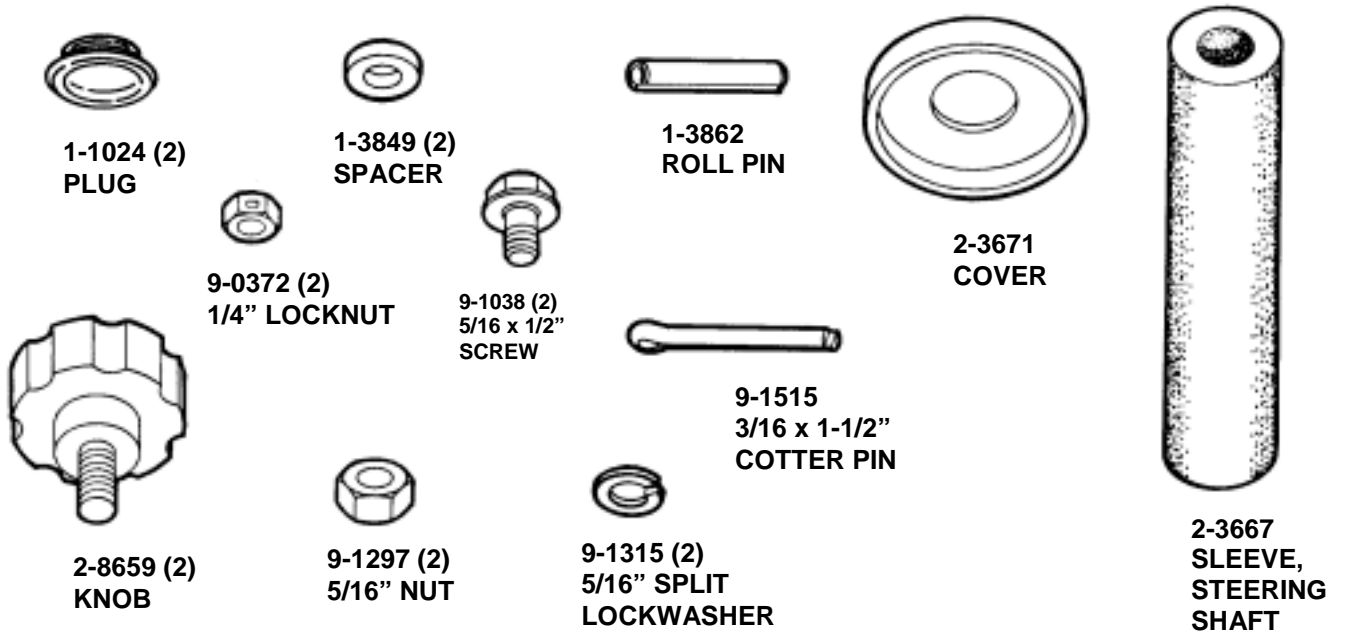

HARDWARE BAG 6-3049 (Used on Models: E250816BE, E281016BE, E281216BE and E281318BE)

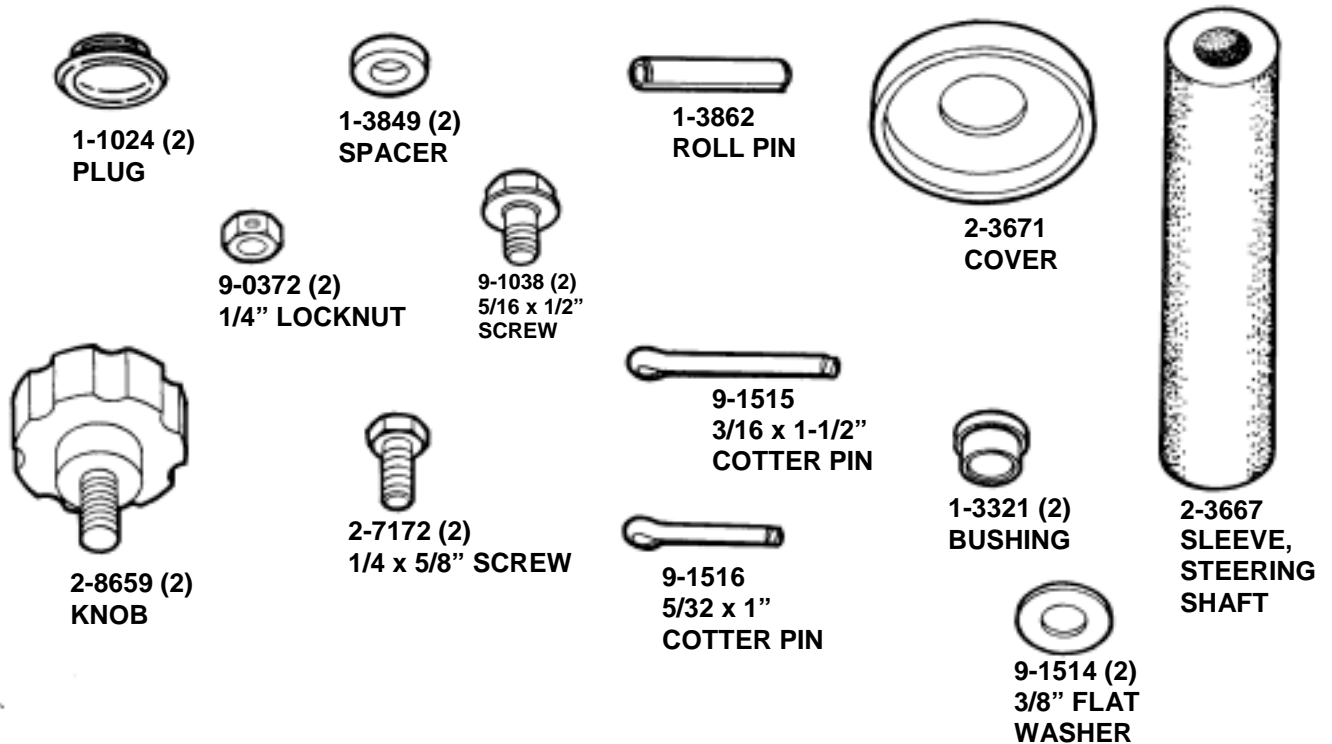

Parts Manual for

SNAPPER[®]

EUROPEAN REAR ENGINE RIDER SERIES 16 & 18

MODELS:

E250816BE

E281016BE

E281216BE

E281318BE

E331316BVE

E331416KVE

E331518KVE

IT IS THE POLICY OF SNAPPER TO IMPROVE ITS PRODUCTS WHENEVER IT IS POSSIBLE AND PRACTICAL TO DO SO. WE RESERVE THE RIGHT TO MAKE CHANGES OR ADD IMPROVEMENTS AT ANY TIME WITHOUT INCURRING ANY OBLIGATION TO MAKE SUCH CHANGES ON PRODUCTS MANUFACTURED PREVIOUSLY.

SNAPPER[®] McDonough, GA., 30253 U.S.A.

COPYRIGHT © 1999
SNAPPER INC.
ALL RIGHTS RESERVED