

Safety Instructions & Operator's Manual for

SNAPPER®

**SERIES 15
REAR ENGINE RIDER
MOWERS
MODELS**

**E250815BE
E280915BE
E331315BE
E331415KVE**

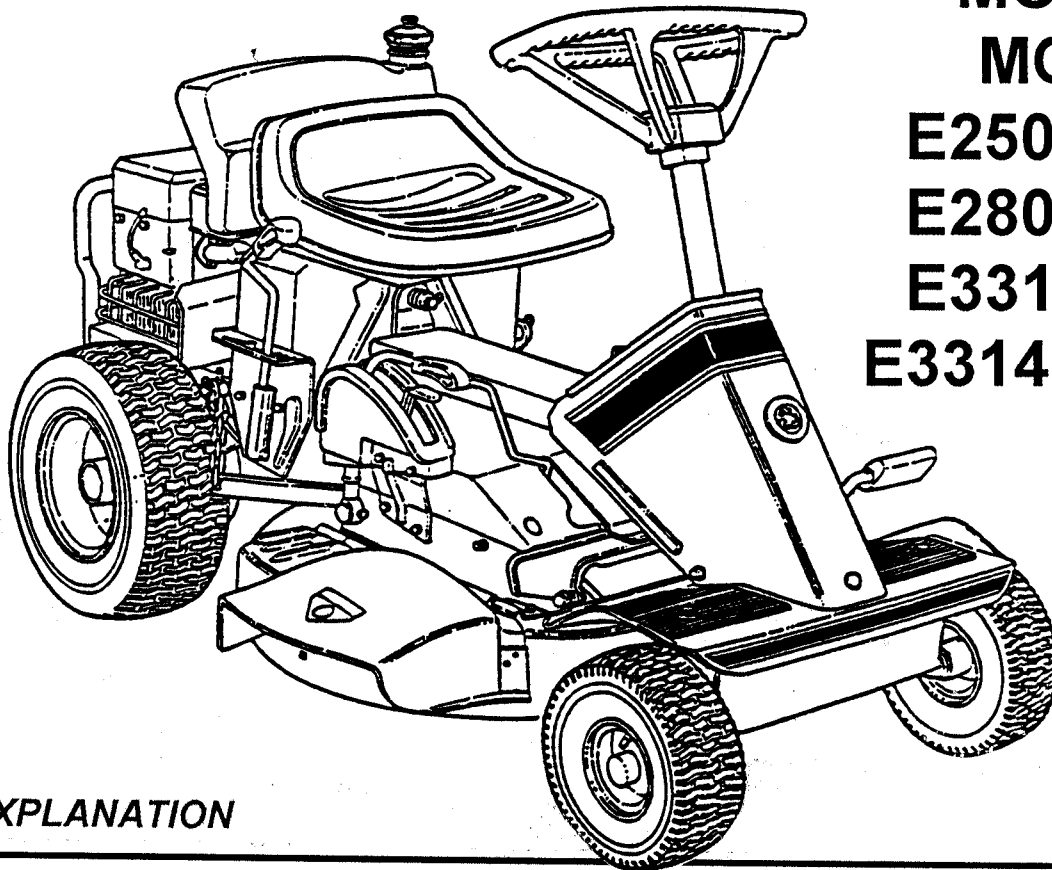

MODEL EXPLANATION

EURO	PREFIX	BODY	SUFFIX
E	331415	K	VE
CUTTING WIDTH	ENGINE HP	SERIES DESIGNATION	ENGINE AND OPTIONS

<p>PREFIX EXPLANATION E = EUROPEAN VERSION 25 = 25" CUTTING WIDTH 28 = 28" CUTTING WIDTH 33 = 33" CUTTING WIDTH</p>	<p>BODY EXPLANATION 15 = DESIGN SERIES</p>
<p>08 = 8HP ENGINE 09 = 9HP ENGINE 13 = 13HP ENGINE 14 = 14HP ENGINE</p>	<p>SUFFIX EXPLANATION B = BRIGGS & STRATTON ENGINE K = KOHLER ENGINE V = OVERHEAD VALVE ENGINE E = ELECTRIC START ENGINE</p>

Thank you for buying a SNAPPER Product! Before operating your **SERIES 15 REAR ENGINE RIDER**, read this manual carefully and pay particular attention to the "IMPORTANT SAFETY INSTRUCTIONS" on Page 2. Remember that all power equipment can be dangerous if used improperly. Also keep in mind that SAFETY re-quires careful use in accordance with the operating instructions and common sense!

IMPORTANT SAFETY INSTRUCTIONS

WARNING: This powerful cutting machine is capable of amputating hands and feet and can throw objects that can cause injury and damage! Failure to comply with the following SAFETY instructions could result in serious injury or death to the operator or other persons. The owner of the machine must understand these instructions and, furthermore, must allow only persons who understand these instructions to operate machine. Each person operating the machine must be of sound mind and body and must not be under the influence of any substance which might impair vision, dexterity, or judgment. If you have any questions pertaining to your machine which your dealer cannot answer to your satisfaction, call or write the Customer Service Department at SNAPPER, McDonough, Georgia 30253. Phone: (770) 954-2500.

PROTECTION FOR CHILDREN

1. DO NOT allow children in yard when machine is operated (even with the blade OFF).
2. DO NOT allow children to ride on machine or on attachments (even with the blade OFF).
3. DO NOT allow pre-teenage children to operate machine.
4. Only responsible teenagers or adults with mature judgement shall be allowed to operate machine and only under close supervision.
8. Check the area to be mowed and remove all objects such as doormats, sticks, toys, wire, rocks, and other objects that could cause injury if thrown by blade.
9. Know how to STOP blade and engine quickly in preparation for emergencies.
10. Keep people and pets a safe distance from machine.
11. Shields, deflectors, switches, blade controls and other safety devices must be in proper position and functional.

PROTECTION AGAINST TIPOVERS

1. DO NOT operate machine on slopes exceeding 15 degrees (27% grade).
2. On slopes above 10 degrees (18% grade), exercise extreme CAUTION. Turn blade OFF when traveling uphill, also reduce speed and avoid sharp turns.
3. Avoid uphill starts. If machine is stopped going uphill, turn blade OFF and back slowly down the slope.
4. DO NOT mow under any condition where traction or stability is doubtful without first test driving over the terrain with blade OFF.
5. Stay alert for holes and other hidden hazards. Keep away from ditches, washouts, culverts, fences and protruding objects.
6. DO NOT mow back and forth across face of slopes.
7. KEEP A SAFE DISTANCE (at least three feet) away from edge of ditches and other drop offs.

PREPARATION

1. Read this manual, get to know where all controls are located and practice how to use them before starting for the first time, and at the beginning of each season. Pay attention to Warning and Instructional Decals on engine and machine. Read and follow operator's manuals and instructions furnished with attachments.
2. Handle fuel with care! Never remove fuel cap while engine is running. Fill fuel tank outdoors only with engine STOPPED and cool. Clean spilled fuel from machine. Store fuel in approved container, out of the reach of children, in well ventilated, unoccupied building.
3. Only mature, responsible persons shall operate the machine.
4. Mount and dismount the machine from left side.
5. Wear appropriate protective clothing when mowing, such as, long pants and substantial footwear, not barefoot or with open sandals.
6. Practice operation of machine with blade OFF to learn controls and develop skill.
7. Persons under the influence of alcohol or drugs must NOT operate machine.

OPERATIONAL PRECAUTIONS

1. STOP blade, STOP engine and remove key when leaving machine.
2. DO NOT operate machine unless properly seated with feet on foot rests or pedal.
3. Keep hands and feet away from rotating blade underneath deck. Never place foot on ground while blade is ON or when machine is in motion.
4. Turn blade OFF, STOP engine and wait for blade to STOP before attempting to unclog grass or leaves to prevent loss of fingers or hand.
5. Blade must be switched OFF except when cutting grass. Set cutter in highest position when mowing over rough ground.
6. Deflector or grass catcher must be in position. Never point discharge at people, passing cars, windows or doors. Watch out for traffic when crossing or near roadways.
7. Operate in reverse only with careful observation of entire area behind the machine. DO NOT mow in reverse unless absolutely necessary.
8. Service machine and make adjustments only when engine is stopped.
9. Have machine serviced by an authorized SNAPPER dealer at least once a year and have the dealer install any new safety devices.
10. Use only genuine SNAPPER replacement parts to assure that original standards are maintained.
11. Tighten all nuts, bolts and screws frequently, then check, adjust, repair or replace brakes as needed.
12. Lubricate machine at intervals specified in manual to prevent controls from binding.
13. Mow only in daylight or with good artificial light.
14. DO NOT change engine governor speed settings or overspeed engine.
15. Check grass catcher components frequently for signs of wear or deterioration and replace as needed to prevent injury from thrown objects going through weak or worn spots.
16. Exercise CAUTION when pulling loads. Limit loads to those you can safely control and attach loads to hitch plate as specified with SNAPPER attachment instructions.

Section 1 - FAMILIARIZATION

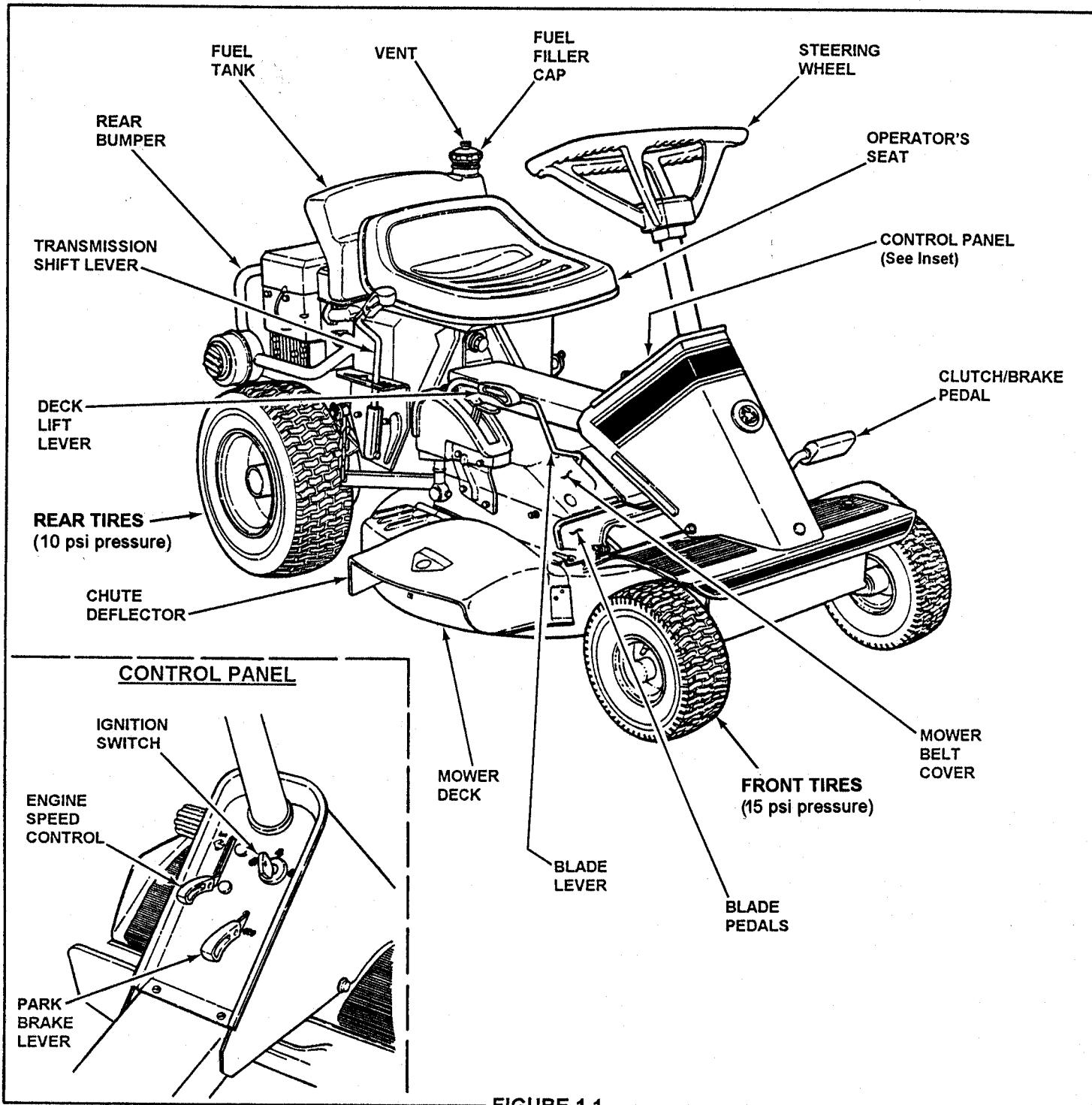

FIGURE 1.1

1.1 INTRODUCTION

This manual has been prepared for the operators of the SNAPPER Series 15 REAR ENGINE RIDER. Its purpose, aside from recommending standard operating procedures and routine service requirements, is to promote SAFETY through the use of accepted operating practices. **Read, Understand and Follow** the IMPORTANT SAFETY INSTRUCTIONS on Page 2 of this manual and All SAFETY messages on the Rear Engine Rider and its attachments before operating.

1.2 NOMENCLATURE

The nomenclature drawing above, Figure 1.1, shows the essential parts of the SNAPPER Series 15 Rear Engine Rider. It is recommended that all operators of this equipment become thoroughly familiar with the controls, components, and operation of this machine before operating. Specific details involving the engine are found in the separate engine owner's manual. Study these manuals before operating and keep both handy for future reference.

Section 2 - OPERATING INSTRUCTIONS

2.1 PRE-START CHECK LIST

Make the following checks and perform the service required before each start-up.

- 2.1.1. Check tires and add (or release) air as needed to bring pressure to 15 psi in front and 10 psi in rear tires.
- 2.1.2. Check guards, deflectors and covers to make sure all are in place and securely tightened.
- 2.1.3. Check engine oil and add oil as needed to bring level up to the full mark. Refer to engine owner's manual for oil specifications. See Figure 2.1.

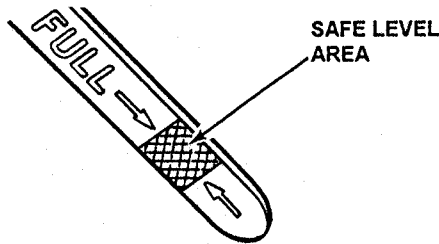

FIGURE 2.1

- 2.1.4. Adjust seat as needed to most comfortable position. See Figure 2.3.
- 2.1.5. Check blade control to insure it works freely. Note: If blade pedals are depressed, blade lever can be moved manually from ON to OFF to stop blade.



CAUTION

The blade control lever must snap from "ON" to "OFF" when blade pedals are released. If blade control lever does NOT snap back, check mower belt tension. See Section 4, 4.2.1. MOWER DRIVE BELT ADJUSTMENT on page 13.

- 2.1.6. Clean exterior surfaces of cutting deck and engine of any accumulation of dirt, grass, oil, etc. Keep engine air intake screen and cooling fins clear at all times.
- 2.1.7. Add fuel to tank after pushing the Rear Engine Rider outside where fumes can dissipate. Make sure fuel cap is tight, vent is open, and fuel valve is "ON" after refueling. Refer to engine owner's manual for fuel specifications. See Figure 2.2.

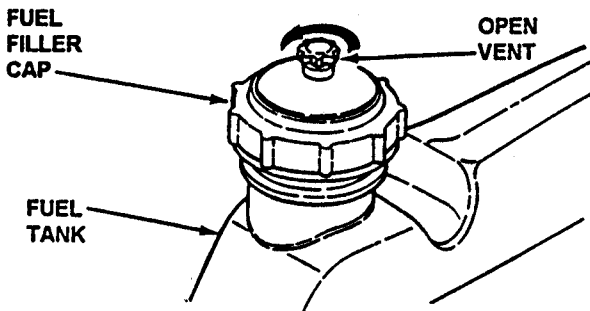

FIGURE 2.2

2.2 OPERATOR'S SEAT

2.2.1. FRONT TO REAR ADJUSTMENT

1. With the engine stopped, loosen the two adjusting knobs, sit on seat and slide seat forward or backward to most comfortable position then tighten both knobs securely. If the seat does not move after loosening knobs, loosen the 5/16" patch lock screws located at the rear of the seat. On 13 and 14 HP models, the seat has to be tilted forward to gain access to the knobs and screws. See Figure 2.3

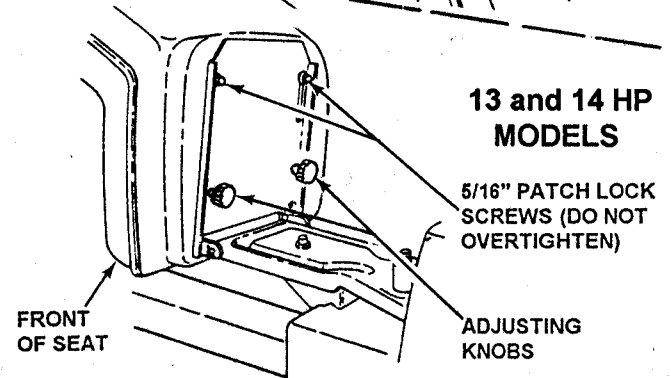
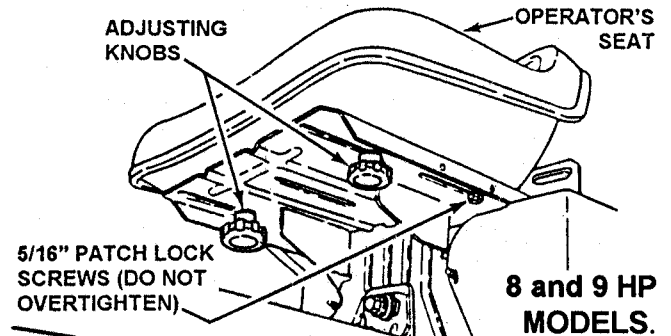

FIGURE 2.3

2.3 STARTING & OPERATION

2.3.1. ELECTRIC START MODELS

IMPORTANT: When the ignition key is turned to "START", the engine will turn over, but will not start unless the Clutch/Brake pedal is pressed all the way down (See Figure 2.5), the Blade Lever is in the "Off" position (See Figure 2.4). The operator should be in the seat. Start engine as follows:

Section 2 - OPERATING INSTRUCTIONS

2.3.2 OPERATION

Electric Start Models: Be seated on the rear engine rider before attempting to start the engine with the key switch.

1. Move transmission shift lever to (N) Neutral position. DO NOT start engine with transmission shift lever in a drive position.

CAUTION

It is possible to start engine with transmission shift lever in a drive position. Follow starting instructions carefully.

2. Make certain the Blade Lever is in the "Off" position. See Figure 2.4.

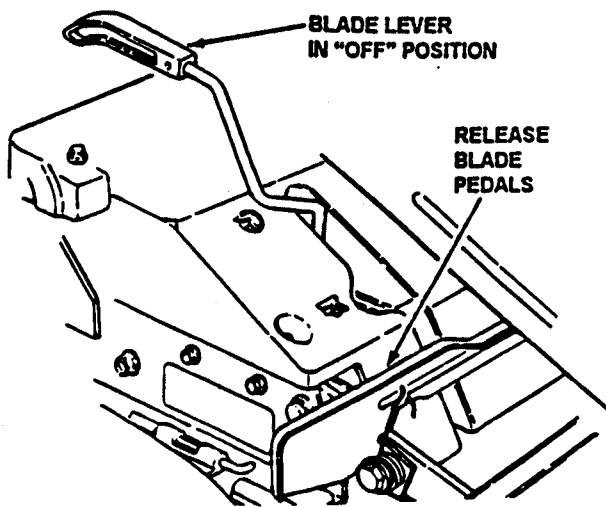

FIGURE 2.4

3. Press Clutch/Brake Pedal all the way down and hold while starting engine. See Figure 2.5.

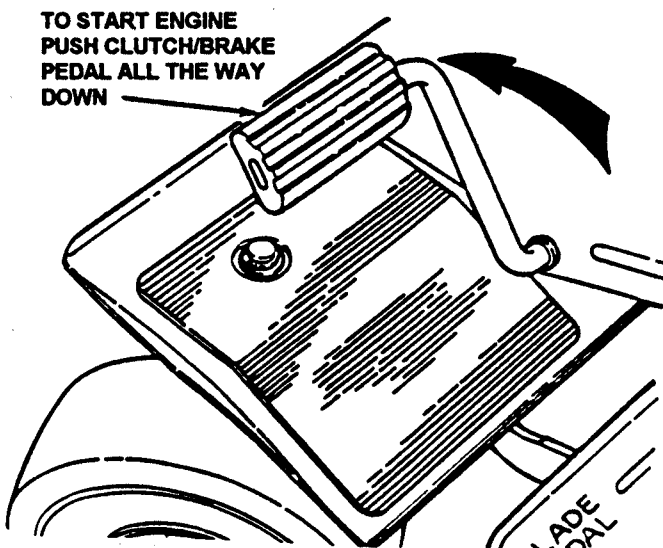

FIGURE 2.5

4. Open vent on fuel filler cap by turning counterclockwise. NOTE: Failure to open vent on the fuel filler cap can cause engine to stall. See Figure 2.6.

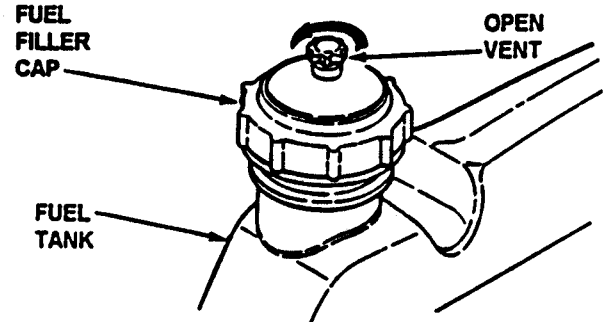

FIGURE 2.6

5. Move engine speed control to the choke position to start a cold engine. See Figure 2.7.

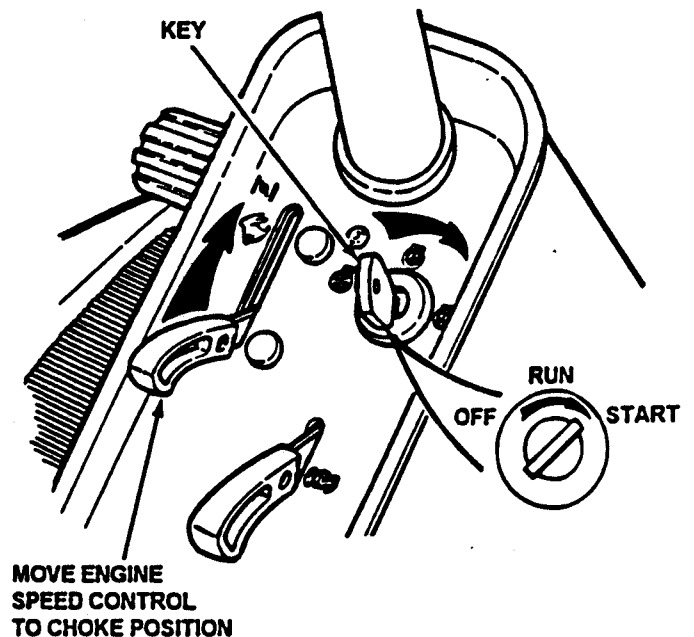

FIGURE 2.7

6. Turn key to the "START" position until engine starts. See Figure 2.7. NOTE: If after 5 seconds of cranking the engine and it does not start, release the key, make sure the Clutch/Brake Pedal is fully depressed and attempt starting again after waiting for approximately 20 seconds.
7. After engine starts, move engine speed control to the "FAST" position, allow a brief warm-up until engine runs smooth.

Section 2 - OPERATING INSTRUCTIONS

2.3.1. MANUAL START MODELS

IMPORTANT: When the ignition key is turned to "RUN", and the recoil handle is pulled, the engine will turn over, but will not start unless the Clutch/Brake Pedal is pressed all the way down with Parking Brake engaged (See Figures 2.5 & 2.8) and the Blade Lever is in the "Off" position (See Figure 2.4). Start engine as follows:

1. Move transmission shift lever to (N) Neutral position. **DO NOT** start engine with transmission shift lever in a drive position.

CAUTION

It is possible to start engine with transmission shift lever in a drive position. Follow starting instructions carefully.

2. Make certain the Blade Lever is in the "Off" position. See Figure 2.4.
3. Press Clutch/Brake Pedal all the way down, lift Parking Brake Lever and release the Clutch/Brake Pedal to set Parking Brake. See Figure 2.8.

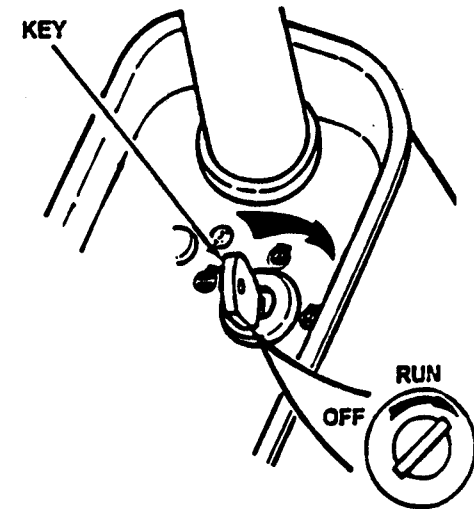

FIGURE 2.9

7. Pull starter rope with a smooth, even motion until engine starts. Always guide the starter rope back into the recoil housing. Never allow rope to snap back. After Engine starts, move engine speed control to the "FAST" position.
8. Allow a brief warm-up until engine runs smooth.

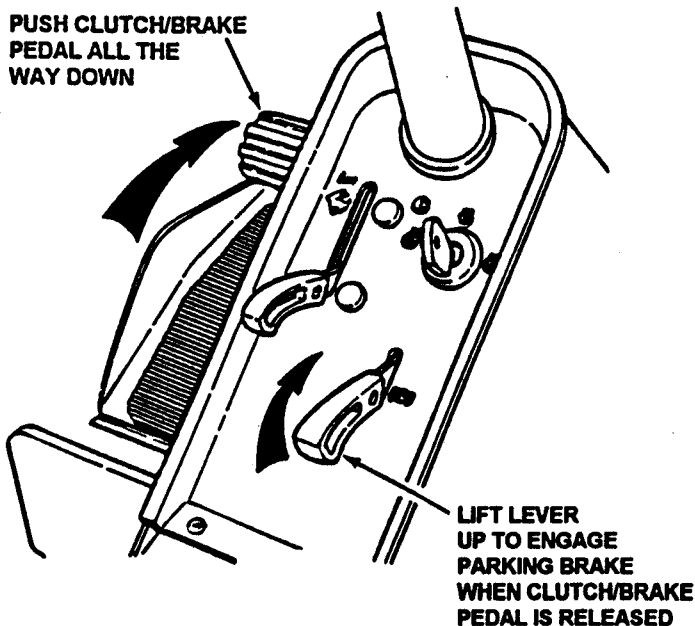

FIGURE 2.8

4. Open vent on fuel filler cap by turning counterclockwise. **NOTE:** Failure to open vent on the fuel filler cap can cause engine to stall. See Figure 2.6.

Section 2 - OPERATING INSTRUCTIONS

2.3.4. MOWER BLADE

1. With engine running, move engine speed control to the "FAST" position.
2. Move blade lever forward and to the right to the "ON" position, then depress blade pedals to hold blade lever in the "ON" position.

NOTE: You cannot engage the blade lever if the blade pedal is depressed first. See Figure 2.14 on Page 7.

2.4 STOPPING

2.4.1. ENGINE

1. Stop engine by turning key to the "OFF" position. See Figure 2.10.

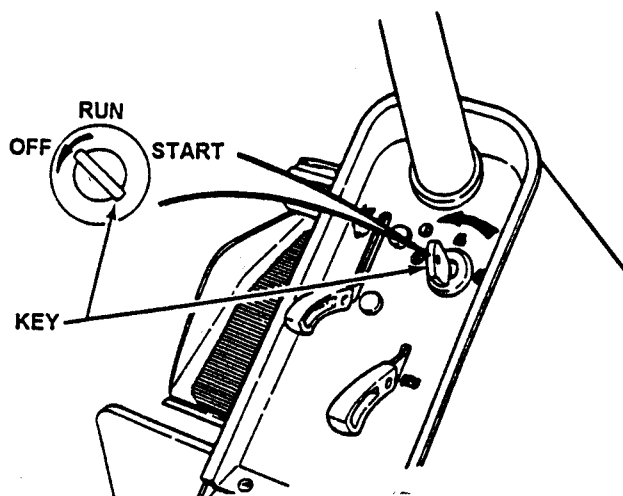

FIGURE 2.10

CAUTION

Before leaving the Rear Engine Rider with the engine running, STOP the blade, shift to neutral and engage the park brake.

2.4.2. WHEEL DRIVE

1. Stop motion of Rear Engine Rider by pushing clutch/brake pedal all the way DOWN to apply brake. See Figure 2.11.

NOTE: Depressing the clutch/brake pedal half way down activates the clutch to allow transmission shifting.

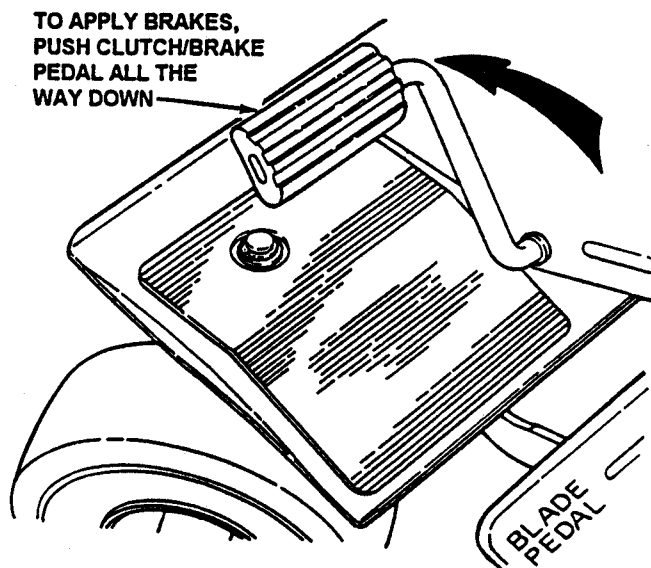

FIGURE 2.11

2.4.3. MOWER BLADE

Stop mower blade by removing feet from blade pedals or moving blade lever to the left and back to "OFF". See Figure 2.12.

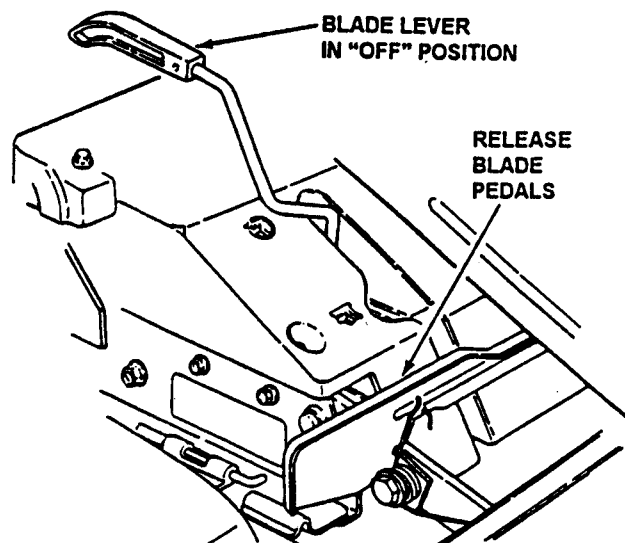

FIGURE 2.12

CAUTION

Once blade is disengaged, it should come to a complete stop in 3 seconds or less. If the blade continues to rotate after 3 seconds, the blade brake should be adjusted. See 4.2.2., BLADE BRAKE ADJUSTMENT on page 14 for adjustment procedures or return machine to dealer for adjustment. DO NOT CONTINUE to operate mower until blade brake is properly adjusted.

Section 2 - OPERATING INSTRUCTIONS

2.4.4. PARK BRAKE

1. Engage park brake by pushing clutch/brake pedal all the way DOWN and moving the park brake lever to the ON position. While holding the park brake lever ON, release clutch/brake pedal to set park brake. See Fig. 2.13.

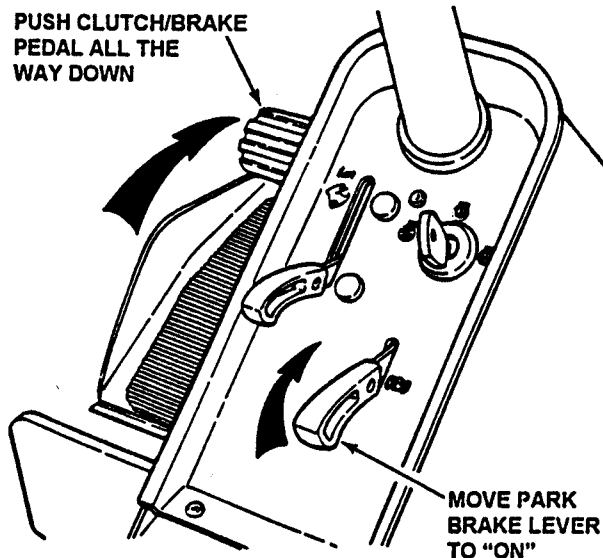

FIGURE 2.13

2. Release park brake by pushing down on the clutch/brake pedal to release park brake lever.

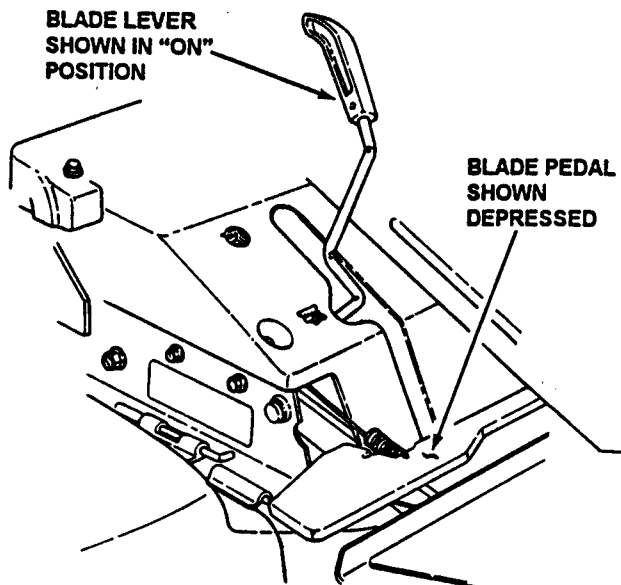

FIGURE 2.14

2.4.5. CUTTING HEIGHT ADJUSTMENT

1. Adjust cutting height as desired to any one of six positions using deck lift lever. When in desired height of cut, release lift lever, then try to move deck lift lever to ensure lift lever latch is fully engaged. See Figure 2.15.

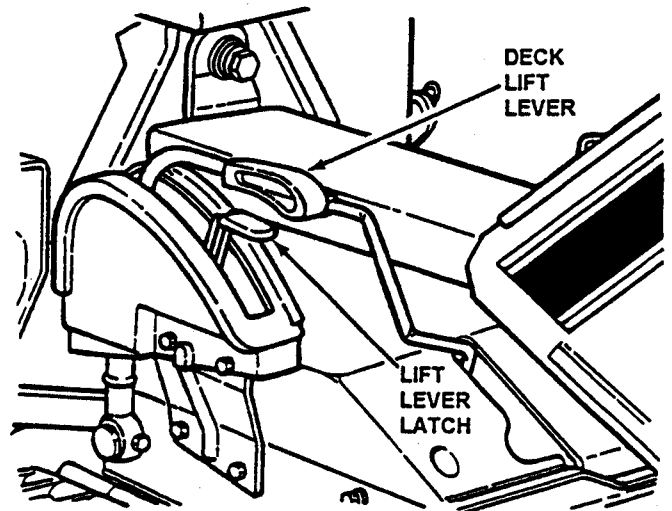

FIGURE 2.15

2.4.6. WHEEL DRIVE

1. With engine running, adjust engine speed control to "FAST" position.
2. Depress clutch/brake pedal.
3. Place transmission shift lever to desired speed.
4. Release clutch/brake pedal to start desired direction.
5. During forward motion, the transmission shift lever may be placed in any desired forward speed without depressing the clutch/brake pedal.

NOTE: For best cutting results, move the transmission shift lever into a slow forward speed and the engine speed control to a fast position. This combination will allow the mower blades to lift the grass while cutting smoothly and evenly.

WARNING

Never park the Rear Engine Rider on an incline or embankment.

Section 2 - OPERATING INSTRUCTIONS

2.4.6. WHEEL DRIVE

1. With engine running, adjust engine speed control to desired position.
2. Depress clutch/brake pedal.
3. Place transmission shift lever in first forward speed.

4. Release clutch/brake pedal to start forward motion.
5. During forward motion, the transmission shift lever may be placed in any desired forward speed without depressing the clutch/brake pedal.

Section 3 - MAINTENANCE

MAINTENANCE SCHEDULE

The following schedule should be followed for normal care of your rear engine rider. You will need to keep a record of your approximate operating time. Determining operating time is easily accomplished by multiplying the time it takes to do one job by the number of times you've done the job.

Safety Items	See	Before 1st Use	Before Ea. Use	Every 5 Hrs.	Every 25 Hrs.	Every 50 Hrs.	Every 100 Hrs.	Season End
Check safety interlock system.	Pg. 5	•						•
Check traction brakes.	Pg.17	•						•
Check mower blade stopping time.	Pg. 14	•		After service of blade drive.				•
Normal Care Items								
Check unit for loose hardware.	N/A	•	•					
Check engine oil level.	*	•		•				
Change engine oil. **	*		•			•		
Change oil and service air cleaner. ***						•		
Check engine air filter pre-cleaner. ***	*				•			
Replace oil cleaner cartridge. ***	*					•		
Inspect or change spark plug.	*							•
Lubricate unit.	Pg. 9 - 11				•			
Lubricate chain case and differential.	Pg. 11						•	
Check tire pressure.	Pg. 4	•			•			
Check fuel filter.	Pg. 11							•
Check battery and clean cables.	Pg. 20				•			•
Clean and sharpen blade.	Pg. 19				•			
Check mower drive belt.	Pg. 9 & 13							

*See engine manufacturer's owner's manual.

**Change oil after first five hours of operation.

***More often in hot (85 F/30 C) weather or dirty operating conditions.

Section 3 - MAINTENANCE

3.1 INTRODUCTION

To retain the quality of the Rear Engine Rider, use genuine SNAPPER replacement parts only. Contact a local SNAPPER dealer for parts and service assistance. For the correct part or information for a particular Rear Engine Riding Mower, always mention the model and serial number. SNAPPER recommends returning the Rear Engine Rider to an authorized SNAPPER dealer annually for inspection and addition of any new devices which might upgrade the safety of the Rear Engine Rider.



CAUTION

Before performing any service or maintenance procedures, always remove key from ignition switch, remove spark plug wire from spark plug and secure spark plug wire away from spark plug.

3.2 SERVICE - AFTER FIRST 5 HOURS

3.2.1. CHANGE ENGINE OIL

1. Change engine oil as follows:

- Raise and block under the rear wheel on side opposite the oil drain or under the front wheels to lower rear of engine on engine with rear located drain.
- Loosen the oil fill cap on engine .
- Place a 2 quart minimum capacity container under the end of the oil drain. Open oil drain. See Figure 3.1 for oil drain types used on Rear Engine Riders.

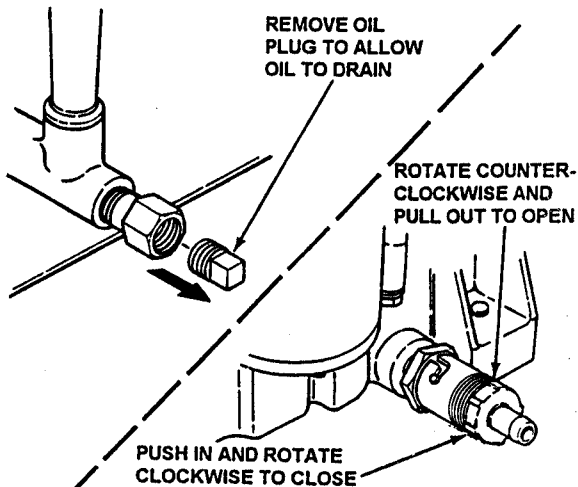

FIGURE 3.1

d. After all the oil has drained, close the drain and wipe up any oil that may have spilled. See Figure 3.1.

e. Add new oil to engine. Refer to your Engine Owner's Manual for the oil specifications and correct oil level.

f. On Twin Cylinder 14HP engines, replace the oil filter at every other oil change. Refer to the Engine Owner's Manual for service instructions.

3.2.2. STANDING MOWER ON END

Stand the Rear Engine Rider on its rear bumper to service items located on the underside. To lift, place both hands near the center of the front end frame to prevent having your fingers pinched by steering linkage parts as the unit is raised. Always take the following steps before standing unit on end. See Figure 3.2

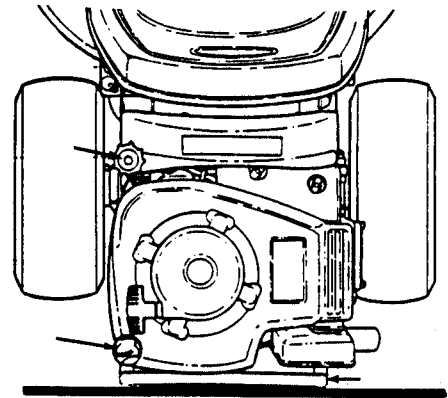

FIGURE 3.2

- Tighten the fuel filler cap and close the vent on cap by turning it clockwise.
- Set the park brake to lock the rear wheels.
- Carefully lift the front end and raise the Rear Engine Rider to stand on its rear bumper. Lifting assistance may be helpful.



CAUTION

Remove the battery if the Rear Engine Rider will be left standing on the rear bumper for longer than 2 hours. See 4.6.1., BATTERY REMOVAL on Page 20.

- Whenever the unit is stood on end, check tightness of the blade mounting bolts and ,if loose, torque 45 to 55 ft. lbs
- Also check blade for sharpness, wear and damage. See 4.4.1., BLADE WEAR LIMITS on Page 18.



WARNING



Never use a cutting blade that shows signs of excessive wear or damage on the Rear Engine Rider. Refer to 4.4, MOWER BLADE REPAIR/REPLACEMENT on Page 18 for proper blade inspection and service procedures.

- Check the blade for straightness. Refer to 4.2.3., ADJUSTING MOWER BLADE on Page 14.

Section 3 - MAINTENANCE

3.2.3. CHECK MOWER DRIVE BELT

1. Drive Belt Cover Removal

- Lower deck to lowest setting.
- Remove four self-tapping screws, two on each side of mower drive belt cover. See Figure 3.3.
- Slide cover back and rotate out on left side of mower deck.

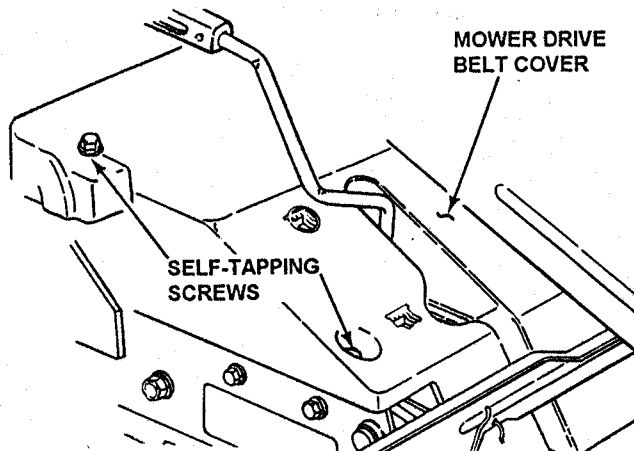

FIGURE 3.3

2. Checking Belt Tension

- The 28" and 33" models have dual idlers to automatically control belt tension. Belt tension is self-adjusting on these models. On 25" models, check tension with engine "OFF", by moving the blade lever up to the "ON" position and depressing blade pedals. See Figure 3.4

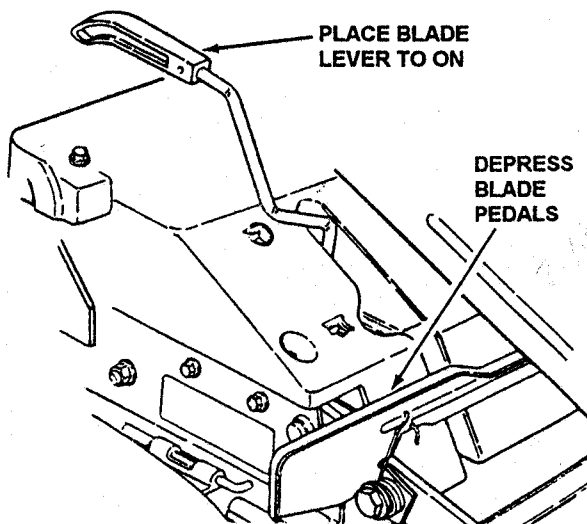

FIGURE 3.4

- On 25" model, measure the distance between belt at idler pulley. See Figure 3.5. The belt spacing should be 1-1/4" but no less than 1". If less than this, refer to Section 4.2.1. MOWER DRIVE BELT ADJUSTMENT on page 13.

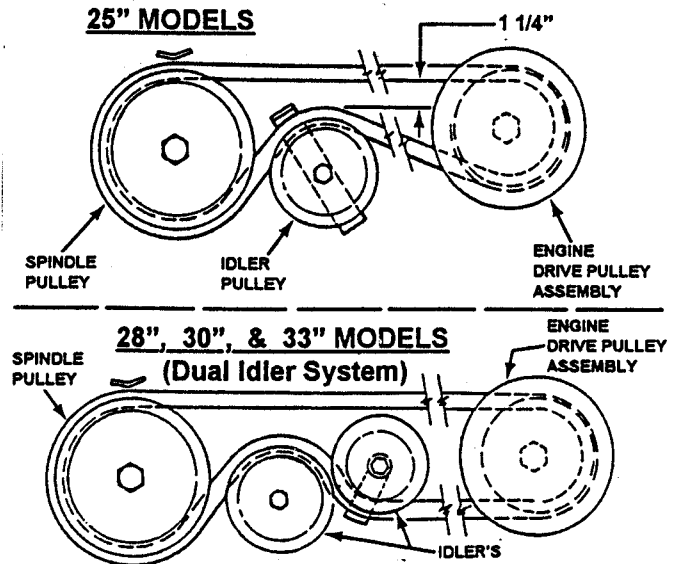

FIGURE 3.5

3.3 AFTER EVERY 25 OPERATING HOURS

3.3.1. ENGINE

1. Engine Oil

Change engine oil. Refer to 3.2.1., CHANGE ENGINE OIL on Page 8. Refer to engine owner's manual for oil specifications.

2. Air Filter

Refer to engine owner's manual for service instructions.

3.3.2. MOWER COMPONENTS SERVICE

1. Mower Drive Belt

Check belt for proper tension or wear. Refer to Section 3.2.3. on this page.

2. Mower Blade

Check blade for sharpness, wear, damage, and torque. Refer to Section 4.4 on Page 18.

3. Mower Deck Levelness

Check mower deck for proper levelness. Adjust if needed. Refer to Section 4.2.4., on Page 15.

4. Cleaning Mower Deck

- Remove key from ignition switch.
- Remove spark plug wire and secure away from spark plug.
- Close vent on fuel filler cap.
- Clean top of deck, removing all grass clippings and debris.
- Carefully stand Rear Engine Rider on rear bumper. Refer to Section 3.2.2.
- Clean the underside of mower deck, removing all accumulation of grass clippings and debris.

Section 3 - MAINTENANCE

NOTE: If the Rear Engine Rider will be on its rear bumper for longer than two hours, remove the battery following instructions in section 4.6.1. on Page 20.

5. Mower Blade Spindle - Lubrication

With Rear Engine Rider standing on rear bumper, lubricate spindle fitting with one shot of General Purpose grease from grease gun. See Figure 3.6.

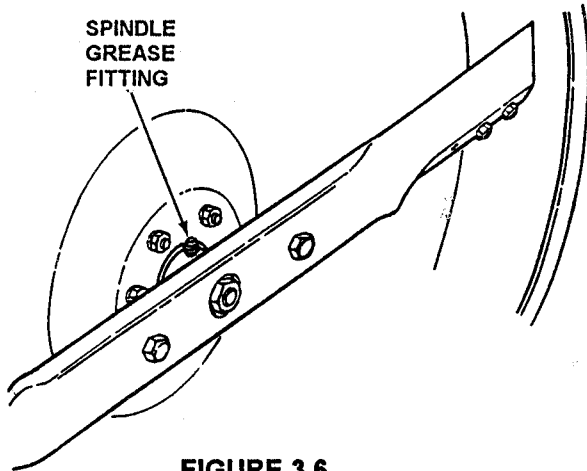

FIGURE 3.6

6. Mower Deck Linkage - Lubrication

Lubricate all mower deck linkage pivot points with a light coat of motor oil.

3.3.3. REAR ENGINE RIDER - LUBRICATION

1. Front Wheel Bearings

With Rear Engine Rider standing on its rear bumper, lubricate the front wheel bearings with five shots of General Purpose grease from grease gun. See Figure 3.7.

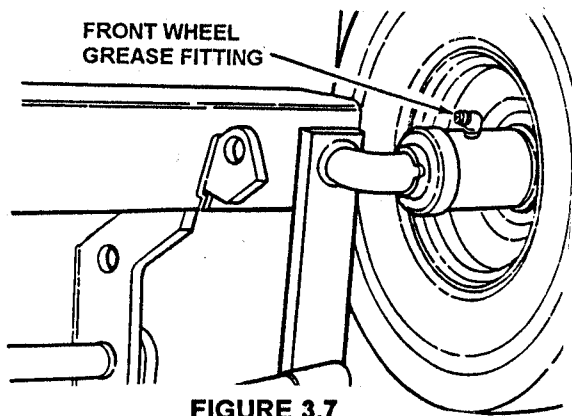

FIGURE 3.7

2. Right Rear Axle Bearing

The right rear axle bearing is lubricated internally by the differential lubricant.

3. Left Rear Axle Bearing

On the 14HP Rear Engine Riders, the left rear axle has no grease fitting. However, on 8HP, 9HP, and 13HP Models, the left rear axle bearing fitting requires 3 shots of General Purpose grease from a grease gun. This is done with the Rear Engine Rider standing on its rear bumper See Figure 3.8.

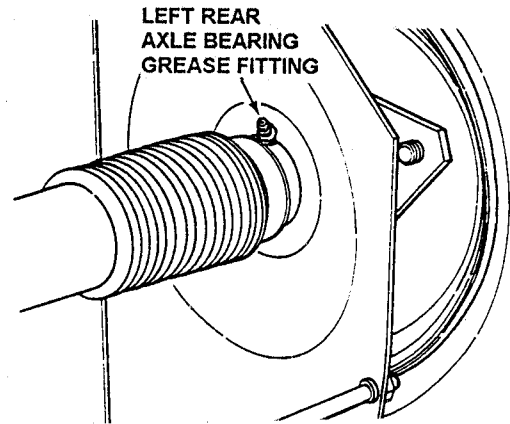

FIGURE 3.8

4. Differential

a. To check lubricant, stand Rear Engine Rider on its rear bumper, remove fill/level plug and visually inspect for lubricant. If lubricant is not seen, add just enough of SNAPPER "OO" grease to bring the level up to the bottom edge of the check hole. DO NOT overfill as excess grease will leak onto drive components and cause slippage. See Figure 3.9

b. Check the fill/level plug for cracks or wear and replace it if needed with a new SNAPPER part number 1-1024 plug.

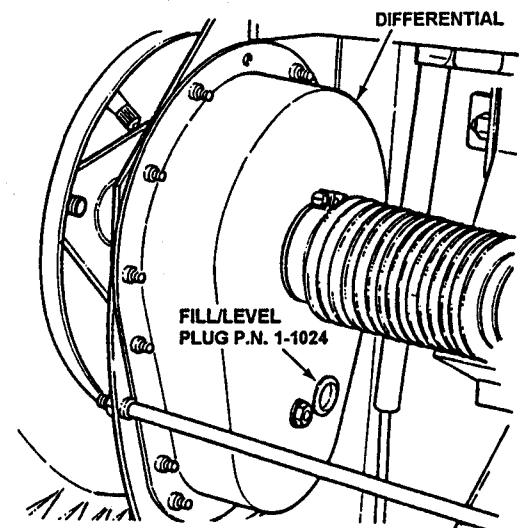

FIGURE 3.9

Section 3 - MAINTENANCE

5. Chain Case

- a. Check lubricant in chain case with Rear Engine Rider standing on its rear bumper by removing fill/level plug and looking for lubricant on the internal components. If lubricant is not visible, add a small amount of SNAPPER "OO" grease until lubricant can be seen below the edge of the hole. See Figure 3.10.
- b. Check the fill/level plug for damage. If worn or cracked, replace it with a new SNAPPER part number 1-1024 plug. See Figure 3.10.

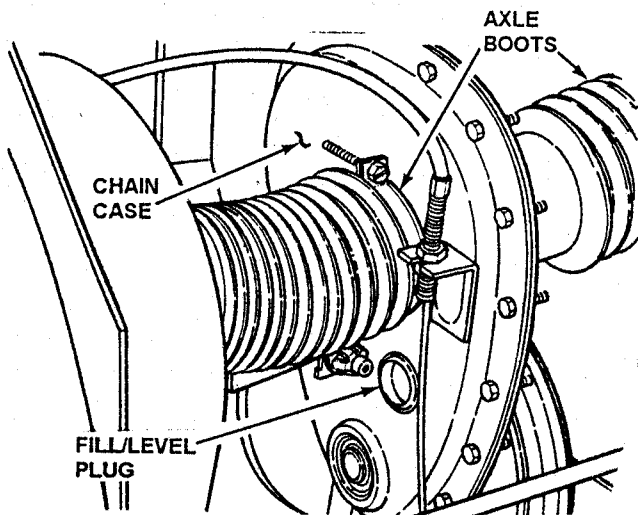

FIGURE 3.10

6. Axle Boots

With Rear Engine Rider standing on its rear bumper, check axle boots for signs of wear or cracks. If cracks or wear are visible, contact a SNAPPER dealer for service. Refer to Figure 3.10.

3.4 ANNUALLY (END OF EACH SEASON)

Perform all maintenance as described in 3.3, "AFTER EVERY 25 OPERATING HOURS" on Page 9.

3.4.1. ENGINE

1. Service the engine following instructions in the Engine Owner's Manual.

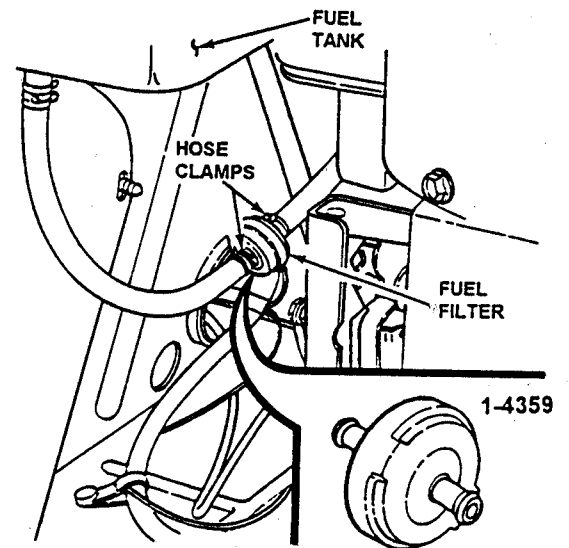

FIGURE 3.11

3.4.2. FUEL FILTER

Replace the fuel filter (on cold engine only) as instructed below. To stop the flow of fuel while disconnecting fuel lines, remove the fuel tank from its bracket and set tank on the floor so fuel level will be below the filter. Refer to section 3.7 on page 12 for Tank Removal procedure.

1. Remove hose clamps from fuel filter.
2. Remove fuel lines from filter. Discard filter.
3. Install a new fuel filter (SNAPPER part number 1-4359). See Figure 3.11.
4. Reinstall fuel tank into bracket.

3.4.3. MOWER DECK

1. Clean all grass clippings and debris from deck.
2. Perform maintenance and lubrication as described in 3.3, AFTER EVERY 25 OPERATING HOURS on Page 9.

3.5 EVERY TWO YEARS

In addition to regular maintenance, the following components of the Rear Engine Rider should be carefully inspected every two years for wear or damage. Replace worn or damaged parts with genuine SNAPPER replacement parts available from an authorized SNAPPER dealer.

- 3.5.1. All bushings and pivot areas.
- 3.5.2. Front Axle Assembly.

Section 3 - MAINTENANCE

3.5 EVERY TWO YEARS (continued)

- 3.5.3. Transmission shift lever and detent.
- 3.5.4. Clutch disc.
- 3.5.5. Yoke arm (see Figure 4.13 on page 16).
- 3.5.6. Mower deck linkage and pivot areas.

3.6 STORAGE (OUT OF SEASON)

If desired, the Rear Engine Rider can be stored on the rear bumper. Perform the following procedures at the end of the season to insure that the Rear Engine Rider will operate properly when taken out of storage.

- 3.6.1. Thoroughly clean the Rear Engine Rider by removing all grass clippings and debris.
- 3.6.2. Perform the maintenance and lubrication services as described in 3.3, AFTER EVERY 25 OPERATING HOURS on Page 9.
- 3.6.3. Drain all fuel from fuel tank. See instructions in 3.7.
- 3.6.4. Start engine and allow it to run until out of fuel. This will allow the carburetor and fuel system not to gum up from stale fuel and remain clean during storage.
- 3.6.5. Remove the battery. See 4.6.5., BATTERY STORAGE on Page 21.
- 3.6.6. Close the vent on the fuel filler cap by turning it clockwise until tight.
- 3.6.7. Carefully stand the Rear Engine Rider on its rear bumper in location for storage if this method is desired.

3.7 REMOVING FUEL TANK

NOTE: As Safety Precautions, always perform this procedure when the engine is cold and with the spark plug wire removed and secured away from the spark plug. Also move the Rear Engine Rider outdoors where gasoline fumes will dissipate.

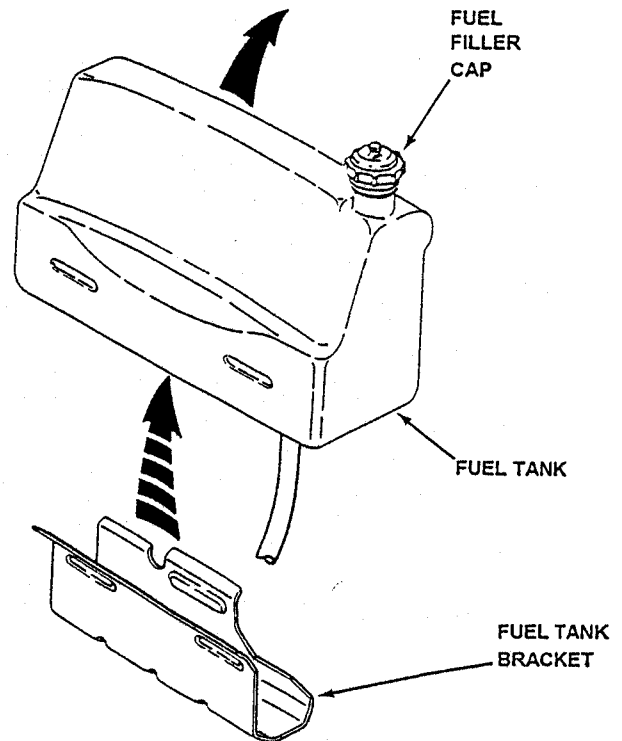

FIGURE 3.12

- 3.7.1. Working from the left side, pull the fuel tank straight up out of the tank bracket. See Figure 3.12.
- 3.7.2. If tank removal is being done to replace the fuel filter as described in 3.4.2., place tank on floor so fuel level is below the filter or proceed with 3.7.3. to remove fuel from tank.
- 3.7.3. Hold the tank in your arm, remove the fuel filler cap then pour all fuel in the tank into an approved gasoline container.

Section 4 - ADJUSTMENTS & REPAIR



CAUTION

Before attempting any adjustments or repairs, remove key, remove spark plug wire from spark plug and secure spark plug wire away from spark plug.

4.1 ENGINE ADJUSTMENTS & REPAIR

Refer to the engine owner's manual for those adjustments and/or repairs that may easily be made by the owner.

4.2 MOWER DECK & COMPONENT ADJUSTMENTS

The following mower deck and component adjustments and repairs might be made by the owner. However, if any difficulty is anticipated, have these done by an authorized SNAPPER dealer.

4.2.1. MOWER DRIVE BELT ADJUSTMENT

(FOR 25" MODELS ONLY) Note that other models have self-adjusting dual idlers.

1. Remove mower drive belt cover. Refer to 3.2.3., CHECK MOWER DRIVE BELT on Page 9.
2. Move blade lever up and over to the "ON" position.
3. Measure belt spacing at the idler pulley. The distance should measure 1-1/4" but not less than 1". See Figure 4.1.

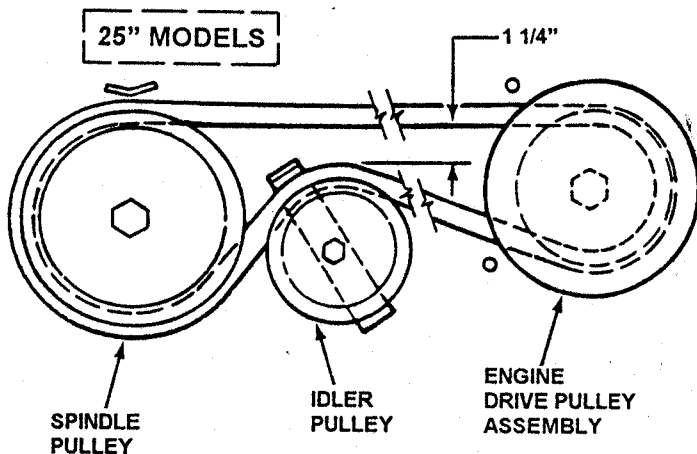
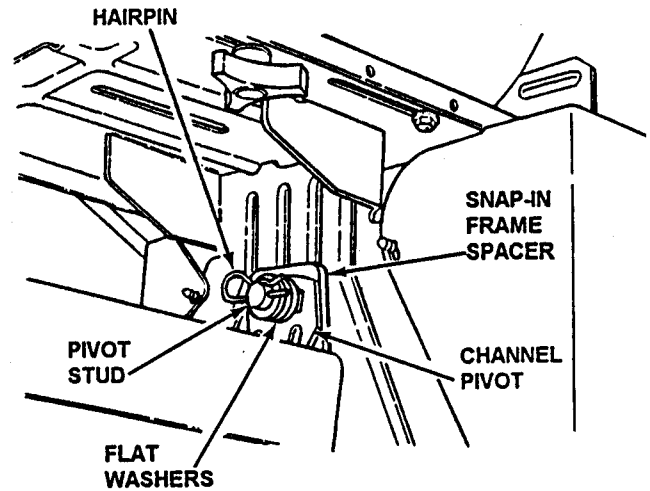

FIGURE 4.1 (25" MODELS)

4. If the distance is less than 1", adjust belt tension by adding snap-in frame spacers as follows:
 - a. Remove hairpin and flat washers from the pivot stud. See Figure 4.2.
 - b. Pull front frame forward until distance between belt, with blade lever "ON", measures 1-1/4".
 - c. Install required number of "snap-in" spacers behind channel pivot until the 1-1/4" distance between belt and idler is obtained. See Figure 4.3.



25" MODELS ONLY

FIGURE 4.2

NOTE: SNAPPER 25" Model Rear Engine Riders are shipped with extra snap-in frame spacers for adjusting belt tension. Should additional spacers be required, order snap-in frame spacers, Part Number 2-8395 from your SNAPPER dealer.

- d. Subtract flat washers as needed to make-up for the thickness of added frame spacers then reinstall the remaining flat washers (removed in step "a.") and reinstall the hairpin. Refer to Figure 4.2. Save any remaining washers for readjustment later when a new belt is installed.

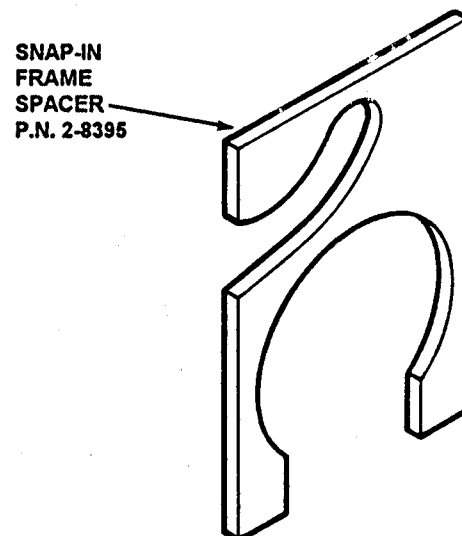

25" MODELS ONLY

FIGURE 4.3

5. On 28" and 33" models, mower drive belt tension does not require adjustment. If the belt does not drive blade properly, replace the deck belt.

Section 4 - ADJUSTMENTS & REPAIR

4.2.2. BLADE BRAKE ADJUSTMENT



CAUTION

When properly adjusted, the blade will stop rotating within 3 seconds after the blade pedals are released. Check stopping time by viewing the mower drive belt behind belt cover. DO NOT remove the belt cover to check stopping time. If adjustment is needed, proceed as follows (or contact an authorized SNAPPER dealer for service). DO NOT continue to operate mower until blade brake is properly adjusted

1. Stop engine and remove belt cover. See Section 3, 3.2.3 on page 9.
2. Remove cotter-pin from eye-bolt swivel.
3. Rotate swivel clockwise several complete rotations. See Figure 4.5.

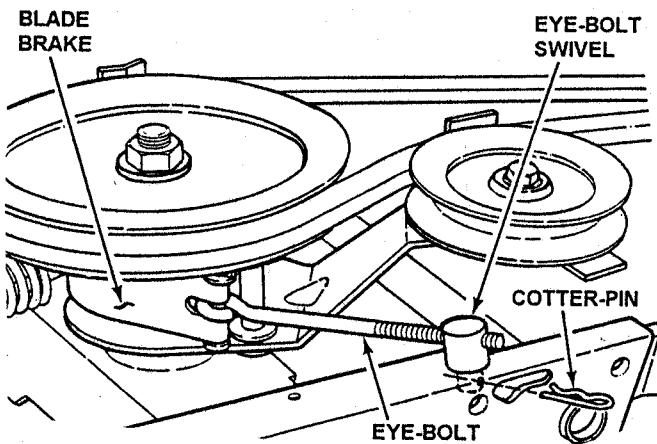

FIGURE 4.5

4. Reinstall swivel and cotter-pin.
5. Depress blade pedals and measure the distance between front of blade lever and latch plate. The distance should be no greater than 1/4". See Figure 4.6.
6. If the distance is greater than 1/4", repeat Steps 1 and 2 until the 1/4" distance is achieved.
6. Reinstall belt cover, re-connect spark plug wire and recheck blade stopping time by observing belt stopping time.

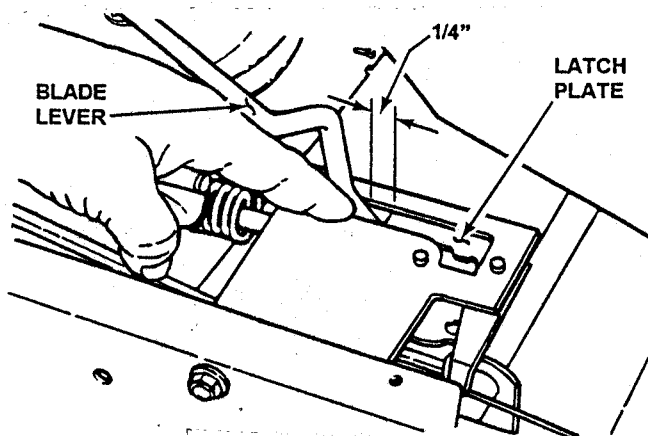

FIGURE 4.6



CAUTION

Before attempting any adjustments or repairs, stop the engine, remove key, remove the spark plug wire from the spark plug and secure the wire away from the plug.

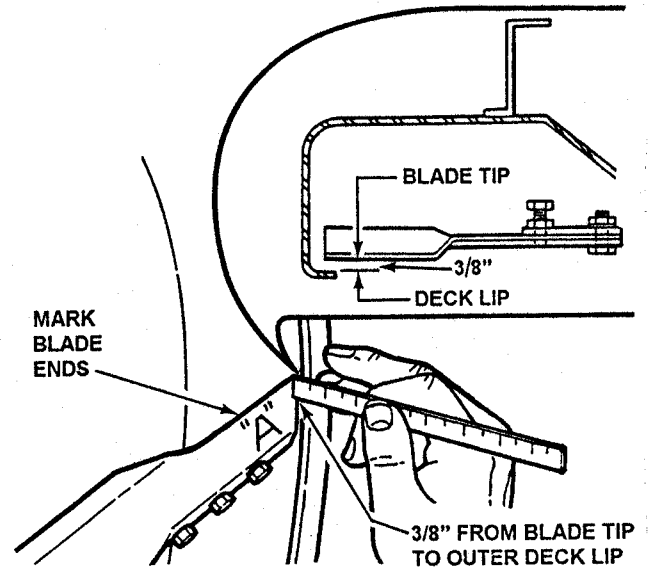

FIGURE 4.7

4.2.3. ADJUSTING MOWER BLADE

Follow procedures for standing Rear Engine Rider on rear bumper.

1. Select a point on the deck and mark for reference.
2. Mark blade tips as "A" and "B".
3. Rotate blade until blade tip "A" is at deck reference mark.
4. Measure the distance between deck lip and blade tip. This should be 3/8". See Figure 4.7.
5. Repeat steps 3 and 4 with blade tip "B".
6. If measurement between blade tips and deck are different and there is more than 1/16" difference between blade tip measurements, adjust blade as follows:
 - a. Loosen jam-nuts on blade bar.
 - b. Adjust jack screws "IN" or "OUT" until blade tip measurements are within 1/16" of each other and blade tips are 3/8" away from deck lip then tighten jam nuts. See Figure 4.8.

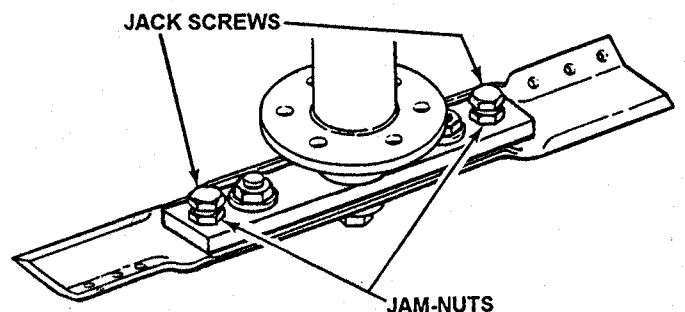

FIGURE 4.8

Section 4 - ADJUSTMENTS & REPAIR

4.2.4. MOWER DECK ADJUSTMENT (LEVELNESS)

If the cut is uneven from side-to-side, check pressure in each tire. The front tires must be set at 20 psi and the rear at 10 psi. If tires are properly inflated and the cut is still uneven, move the Rear Engine Rider onto a smooth, level surface, turn engine off, remove the key then remove and secure the spark plug wire away from spark plug Adjust level as follows:

1. Side-To-Side Level

- a. Raise the deck and place a piece of angle iron or pipe under center rear of the deck.
- b. Disconnect rear hanger cables on 25" models or chains on 28" and 33" from hangers and lower deck to rest on the angle iron or pipe. Count number of ferrules used above and below hanger bracket on 25" models and use the same number when reconnecting. On the 28" and 33" models, remove hair-pin and washer from the chain hanger pivot to disconnect. See Figure 4.9

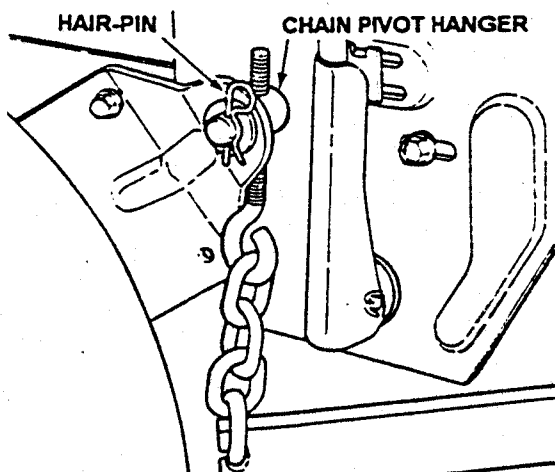
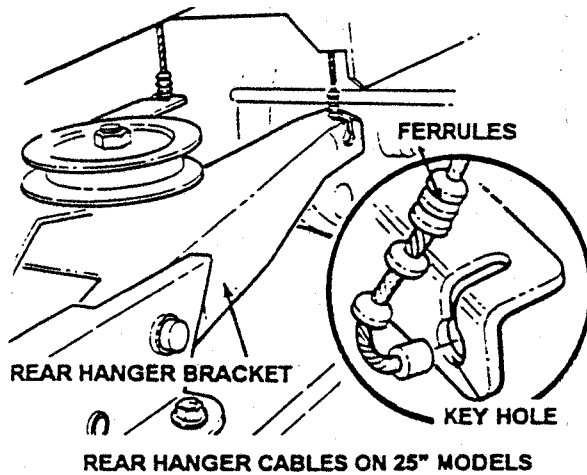

FIGURE 4.9

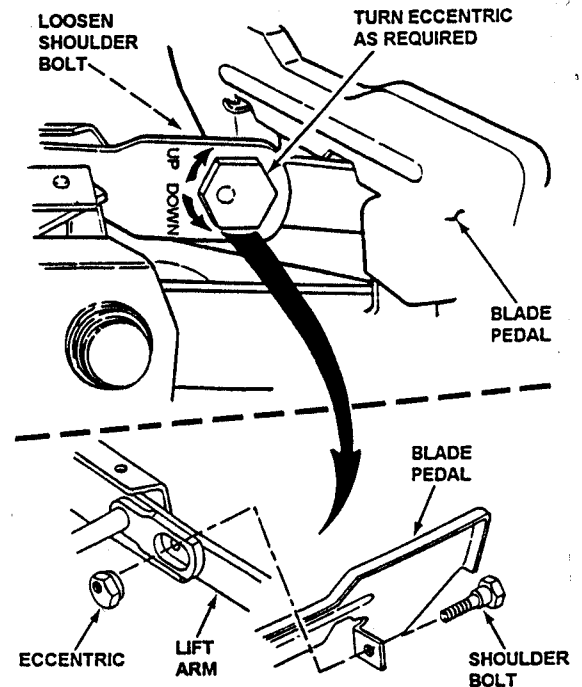

FIGURE 4.10

- c. Measure distance from sides of deck to the floor. If both sides are within 1/8", the deck is level from side-to-side. If more than 1/8", adjust as follows:
- d. Loosen shoulder bolt retaining the left side of blade pedal. See Figure 4.10.
- e. Turn eccentric "UP" or "DOWN" until deck edges are within 1/8" then re-tighten the shoulder bolt, and reconnect hanger cables or chains.

2. Front to Rear Level

Rotate the blade until the tips are at front and rear of deck. Measure the distance from each blade tip to the surface of the floor. These should measure the same or the rear tip should be no more than 1/8" lower than the front tip. If the rear blade tip is higher than the front, adjust as follows:

- a. Remove rear hanger cables on 25" models or chains on 28 and 33" models.
- b. On 28 and 33" models, turn each hanger pivot the same number of rotations on the eye-bolt to raise or lower the rear of the deck. On 25" models, relocate ferrules from below to above the keyslot to lower the rear of deck or reverse to raise rear of deck.
- c. Reinstall rear hanger cables or chains and measure blade tips again.
- d. Repeat steps "a" through "c" until proper level is obtained.

Section 4 - ADJUSTMENTS & REPAIR



CAUTION

Before attempting any adjustments or repairs, stop engine, remove key, disconnect the spark plug wire from the spark plug and secure wire away from plug

4.2.5. MOWER DECK TIMING ROD ADJUSTMENT

The mower deck timing rod is set at the factory to keep the deck in the same attitude through all heights of cut. If the timing rod requires adjustment, contact an authorized SNAPPER dealer. See Figure 4.11.

NOTE: TIMING ROD ADJUSTMENT SHOULD ONLY BE DONE BY AN AUTHORIZED SNAPPER DEALER.

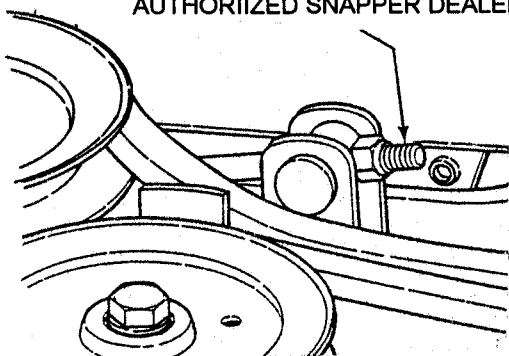

FIGURE 4.11

4.2.6. CUTTING HEIGHT ADJUSTMENT

The deck cutting height may be adjusted to obtain desired cutting heights when using the deck lift lever.

1. Place the Rear Engine Rider on a smooth, level surface.
2. Move deck lift lever to the lowest cutting position.

SHOWN WITH COVER REMOVED

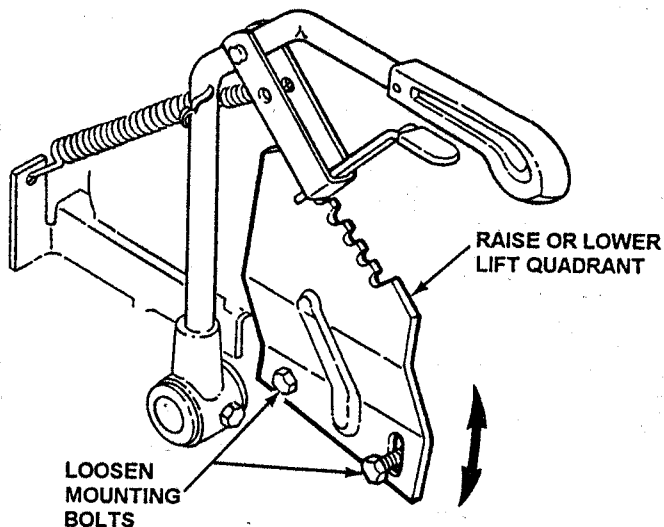

FIGURE 4.12

3. Loosen the two lift quadrant mounting bolts. See Figure 4.12.
4. Rotate the lift quadrant to raise or lower cutting height range. **NOTE:** Lift quadrant in the lowest position should give a 1" to 3-1/2" cutting height range. while in the highest, a 1-1/2" to 4" cutting height range.
5. Tighten lift quadrant mounting bolts.

4.3 DRIVE COMPONENTS ADJUSTMENT

The following drive components may be adjusted by the owner, however, it is recommended that these be done by an authorized SNAPPER dealer.

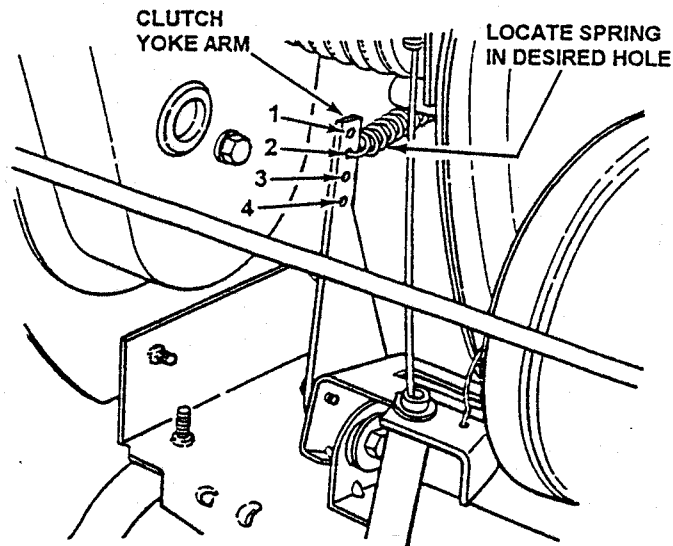

FIGURE 4.13

4.3.1. CLUTCH - STARTING MOTION ADJUSTMENT

If the Rear Engine Rider clutch is too positive or slips excessively when the clutch/brake pedal is released, adjust as follows:

1. Remove key from ignition switch.
2. Remove spark plug wire from spark plug and secure wire away from plug.
3. Close vent on fuel filler cap.
4. Carefully stand Rear Engine Rider on rear bumper.
5. Locate yoke arm between chain case and differential.
6. Move spring to first hole (for positive clutch action) or to 4th hole (to increase slippage). See Figure 4.13

Section 4 - ADJUSTMENTS & REPAIR



CAUTION

Before attempting any adjustments or repairs, stop engine, remove key, remove the spark plug wire from the spark plug and secure wire away from spark plug

4.3.2. CLUTCH - SHIFTING ADJUSTMENT

Test with engine running by depressing clutch/brake pedal, set park brake and move transmission shift lever into a forward speed. If shifting is difficult or will not shift, adjust the clearance between clutch disc and drive disc as follows:

1. Follow procedures for standing the Rear Engine Rider on its rear bumper. Refer to Section 3.2.2,
2. Depress clutch/brake pedal all the way down. Move and hold the park brake lever in the "ON" position, then release clutch/brake pedal to set the park brake.
3. Move the transmission shift lever into reverse position.
4. Visually inspect to make certain there is clearance between clutch disc and drive disc. See Figure 4.14.

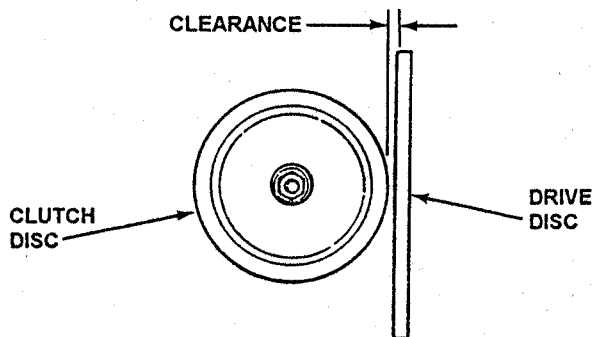

FIGURE 4.14

5. If clearance is not visible, release park brake by depressing clutch/brake pedal to release park brake lever.
6. Pull clutch/brake pedal towards operator's seat and slide 1 additional ferrule toward end of cable and through the eye in the clutch/brake pedal arm. See Figure 4.15.
7. Engage park brake as described in Step 2.
8. Check for clearance between clutch disc and driven disc. If no clearance is visible, repeat steps 5 and 6 until clearance is visible. Refer to Figures 4.14 and 4.15.

NOTE: If adjustment cannot be completed because all ferrules have been used, contact an authorized SNAPPER dealer for service.

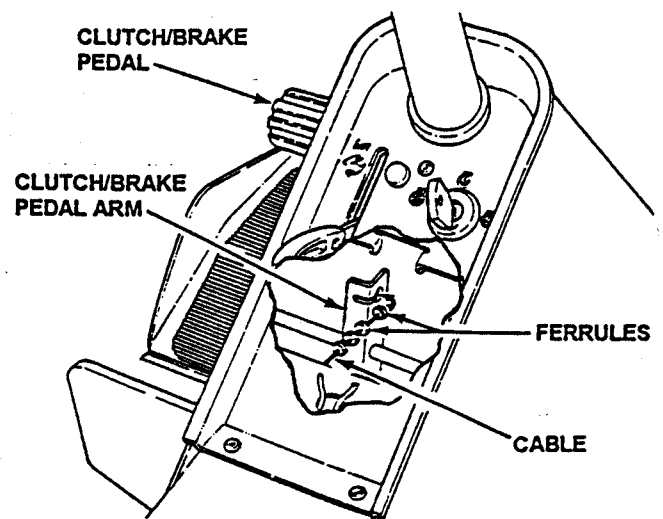

FIGURE 4.15

4.3.3. WHEEL BRAKE ADJUSTMENT

Test the wheel brake on a dry concrete surface. When properly adjusted, the Rear Engine Rider will stop within 3 feet from fastest speed. If stopping distance is more than 3 feet, the wheel brake should be adjusted as follows:

1. Stand Rear Engine Rider on its rear bumper following instructions in Section 3.2.2 on page 8.
2. Push the clutch/brake pedal all the way down. Move the park brake lever up and hold in the "ON" position then release the clutch/brake pedal to set the park brake. See Figure 4.16.

(Continued on page 18)

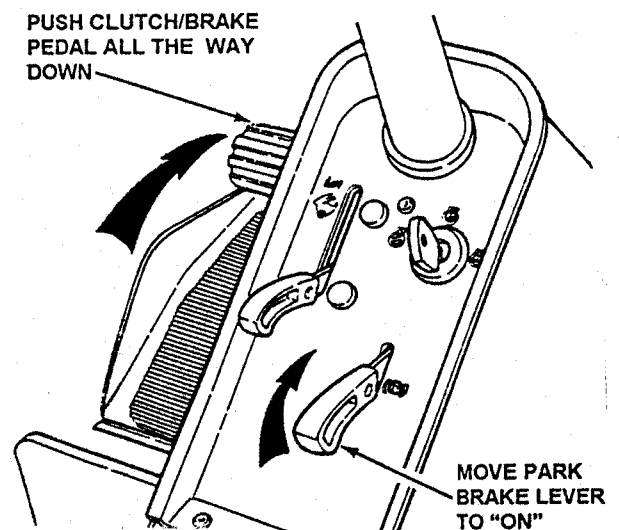

FIGURE 4.16

Section 4 - ADJUSTMENTS & REPAIR

4.3.3. WHEEL BRAKE (Continued)

3. Measure the distance between end of clutch/brake cable and top of cotter pin. Measurement should be no less than 1/2" and no greater than 3/4". See inset on Figure 4.17.

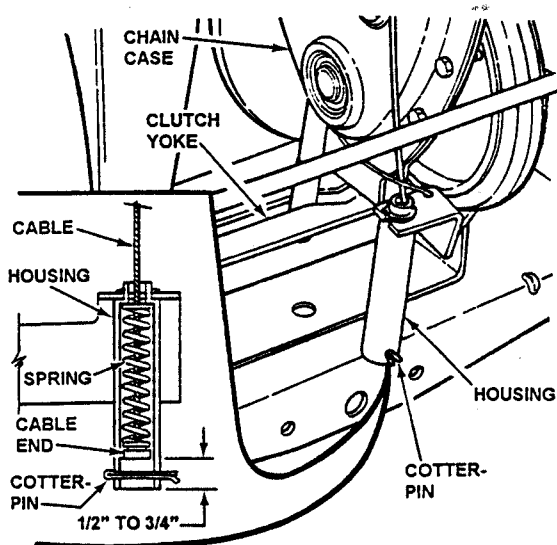

FIGURE 4.17

4. If this measurement is less than 1/2" or greater than 3/4", loosen the two jam nuts holding the clutch/brake cable to the chain case bracket. See Figure 4.18.
5. Adjust cable up or down using the jam nuts to obtain a distance of 1/2 to 3/4" between end of clutch/brake cable (adjustment shown in inset, Figure 4.17) and end of housing.
6. After adjustment is complete, securely tighten cable jam-nuts shown in Figure 4.18.

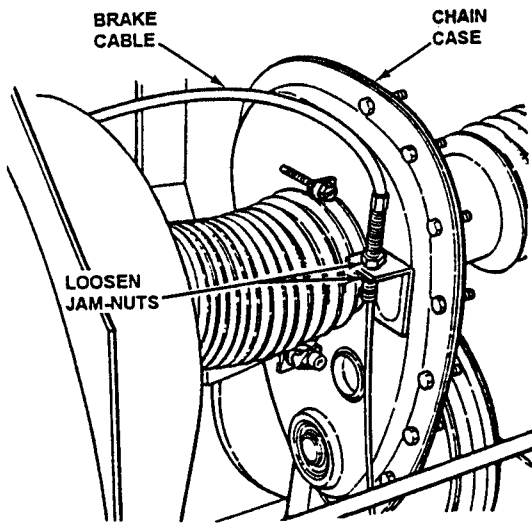

FIGURE 4.18

4.4 MOWER BLADE REPAIR/REPLACEMENT

4.4.1. BLADE WEAR LIMITS

1. Inspect blade frequently for signs of excessive wear or damage. See Figure 4.19.

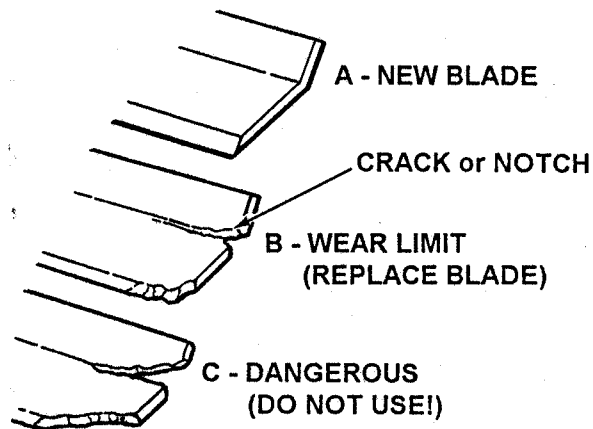

FIGURE 4.19

⚠ WARNING ⚠

Never use a cutting blade that shows signs of excessive wear or damage on the Rear Engine Rider. Refer to Figure 4.19.

4.4.2. BLADE SHARPENING PROCEDURE

1. Stand the Rear Engine Rider on its rear bumper following instructions in Section 3.2.2 on page 8.
2. Remove blade. See Figure 4.20.

⚠ CAUTION ⚠

Before performing any service on blade, turn engine OFF, remove key, remove spark plug wire from spark plug, and secure spark plug wire away from spark plug.

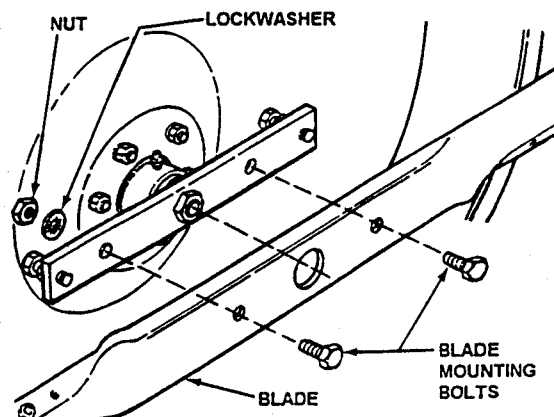

FIGURE 4.20

Section 4 - ADJUSTMENTS & REPAIR

4.4.2. BLADE SHARPENING (Continued)

3. Inspect condition of the blade. Replace it if needed. Refer to Figure 4.19 for limits.
4. If the blade is in good condition, sharpen cutting edge at 25 degrees. DO NOT sharpen beyond the existing cutting edge. See Figure 4.21.

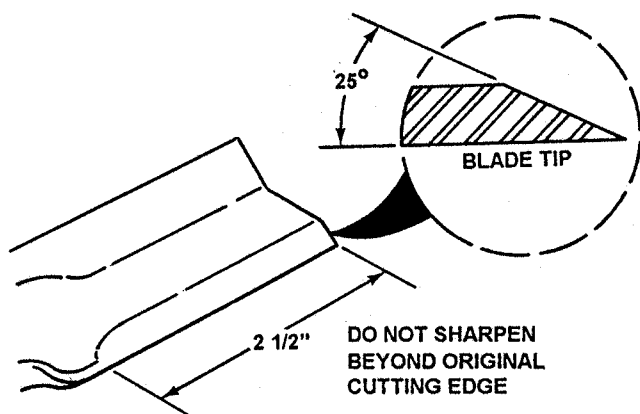

FIGURE 4.21

5. Check blade balance after sharpening. If necessary, correct blade balance by grinding the heavy end of blade.
6. Reinstall blade as shown in Figure 4.20. Tighten blade mounting bolts 45 to 55 ft. lbs with a torque wrench.



CAUTION

On Rear Engine Riders equipped with a grass catcher attachment, the air lifts should be replaced when the blade is replaced.

4.5 MOWER DRIVE BELT REPLACEMENT

Inspect mower drive belt as described in 3.2.3., on Page 9. and replace belt if signs of excessive wear and/or damage are present.



CAUTION

Before attempting any adjustments or repairs, STOP the engine, remove the key, remove the spark plug wire from the spark plug and secure wire away from plug.

4.5.1. BELT REMOVAL

1. Remove the mower drive belt cover. Refer to 3.2.3., on Page 9.
2. Remove the old belt from pulleys.

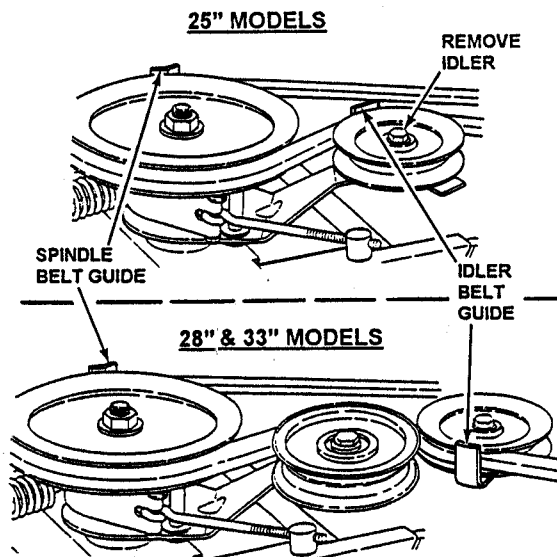

FIGURE 4.22

4.5.2. BELT REPLACEMENT

1. Remove idler. See Figure 4.22.
2. Move the transmission shift lever to the neutral (N) position.
3. Stand the Rear Engine Rider on its rear bumper following instructions in Section 3.3.2. on page 9.
4. Route belt through front belt guide to engine pulley/drive disc assembly. Route belt as shown for the model involved as shown in Figure 4.22.
5. Rotate clutch yoke arm (shown in Figure 4.13 on page 16) out of way by hand then work belt between drive and driven discs.
6. Move transmission shift lever to the #5 position and place belt over drive disc and into drive pulley belt groove. See Figure 4.23.
7. Route belt onto spindle pulley. Make sure belt is inside the spindle belt guide and inside the idler belt guide. See Figure 4.23.
8. Reinstall the idler removed in step 1. The idler belt guide will self-locate on tab. Tighten bolt securely.

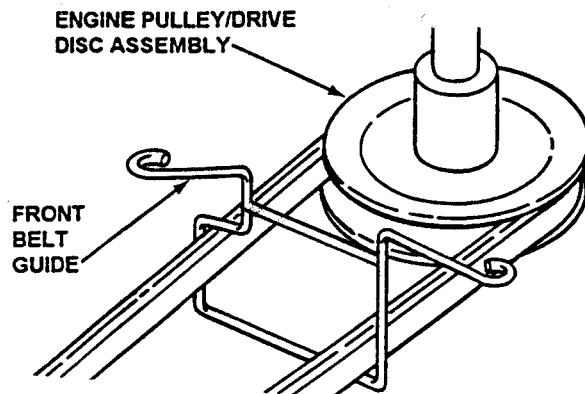

FIGURE 4.23

Section 4 - ADJUSTMENTS & REPAIR

9. Adjust belt guide. See Figure 4.24 for proper belt-to-belt guide clearances.
10. Check mower drive belt tension and adjust if necessary. Refer to 4.2.1., MOWER DRIVE BELT ADJUSTMENT on Page 13.
11. Reinstall mower drive belt cover.

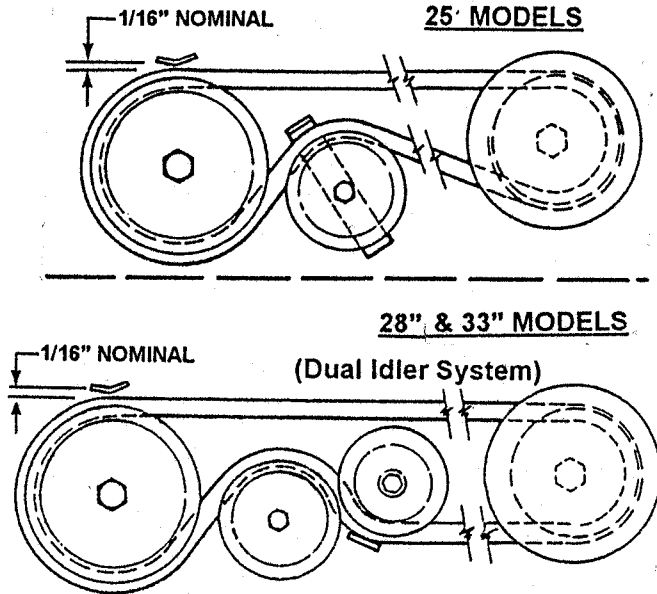

FIGURE 4.24

4.6 BATTERY SERVICE



CAUTION

Never attempt to service or charge the battery while it is installed on the Rear Engine Rider.

4.6.1. BATTERY REMOVAL

1. Carefully pull each side of battery cover away from ratchet fasteners and remove cover. See Figure 4.25.

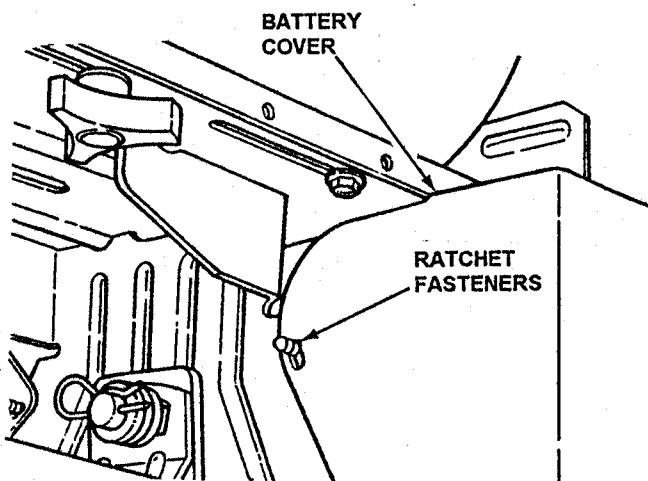

FIGURE 4.25

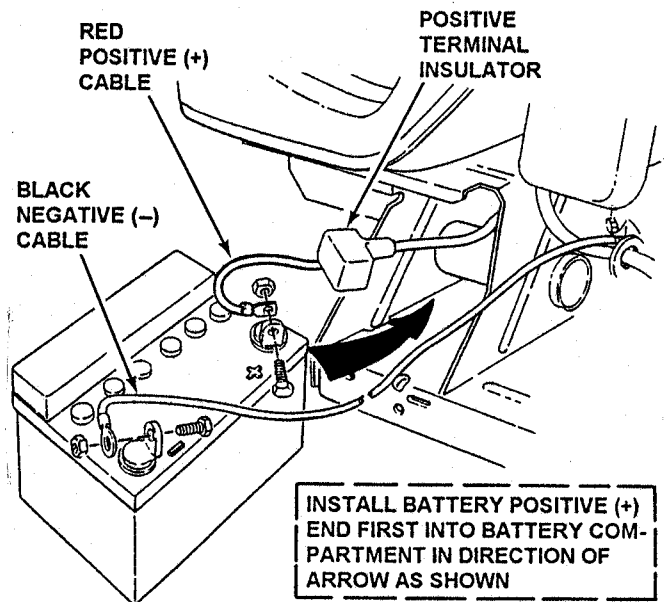

FIGURE 4.26

2. Slide battery from battery box to gain access to terminal cables.
3. Observe and note cable positions on battery. See Figure 4.26.
4. Disconnect black (negative) cable first then the red (positive) cable from battery terminals. Retain mounting bolts and nuts.

4.6.2. BATTERY INSTALLATION

1. Slide battery partially into battery housing.
2. Connect red (positive) cable first then the black (negative) cable to the correct battery terminals. See Figure 4.26.



CAUTION

Cables must be connected to battery terminals in the proper position as show in Figure 4.26.

3. Reinstall battery cover. See Figure 4.25.

4.6.3. BATTERY CHARGING PROCEDURE



CAUTION

Never attempt to charge battery while installed on the Rear Engine Rider. Never use "BOOST" chargers on the battery.

1. Remove battery. Refer to 4.6.1.
2. Place battery in a well ventilated area on a level surface.
3. Remove battery cell caps. Check fluid level of each cell. Fill cells as required with distilled water to proper level.

Section 4 - ADJUSTMENTS & REPAIR

4. With cell caps removed, connect battery charger to battery terminals. Red to positive (+) terminal and black to negative (-) terminal.
5. Slow charge battery at 1 amp for 10 hours.
6. If battery will not accept charge or is partially charged after 10 hours of charging at 1 amp, replace with new battery, P.N. 6-0753.

4.6.4. BATTERY STORAGE

If Rear Engine Rider is to be stored out of season on its rear bumper, it is essential the battery be removed and stored to prevent leakage of electrolyte (acid).

1. Remove battery. See 4.6.1.
2. Perform battery service.
3. Bring battery to full charge, if required.
4. Store battery in an area away from the Rear Engine Rider on a wood surface. **DO NOT STORE BATTERY ON A CONCRETE SURFACE.**

PERFORMANCE DATA

MOWER MODEL:	ENGINE RPM (BLADE ON)	STEERING WHEEL VIBRATION (Max.)	SEAT VIBRATION (Less Than)
E250815BE	3100	11.1 w/sec 2 RMS	3.2 m/sec ²
E280915BE	2930	8.9 w/sec 2 RMS	3.2 m/sec ²
E331315BE	3200	8.6 w/sec 2 RMS	3.2 m/sec ²
E331415KVE	3090	9.9 w/sec 2 RMS	3.2 m/sec ²

ACCESSORIES

KIT DESCRIPTION	FOR MODELS	ORDER SNAPPER KIT NUMBER
LOAD CARRIER	ALL	6-0197
WHEEL WEIGHT	ALL	6-0517
DUMP CART	ALL	6-0697
WEIGHT	ALL	6-1190
THATCHERIZER	ALL	6-0948
CATCHER, SINGLE BAG	25"	6-0941
CATCHER, SINGLE BAG	28 & 33"	6-0943
CATCHER, TWIN BAG	28 & 33"	6-0946
BAG-N-WAGON	28 & 33"	6-0947
COVER, BAG-N-WAGON	28 & 33"	6-0984
RECYCLING KIT	25"	6-1049
NINJA BLADE	28"	6-1253
NINJA BLADE	33"	6-1255

EUROPEAN DECALS

BREMSBETRIEB
ANHALTEN: KUPPLUNGS/BREMSPEDAL TRETEN.

ANZIEHEN DER PARKBREMSE: KUPPLUNGS/BREMSPEDAL TRETEN, PARKBREMSENZUGRIEGEL HOCHZIEHEN UND KUPPLUNGS/BREMSPEDAL LOSLASSEN.

ZUM LOSLASSEN DER PARKBREMSE: KUPPLUNGS/BREMSPEDAL TRETEN.

BETRIEB DES MESSERS

EINSCHALTEN DES MESSERS: MESSERHEBEL AUF „ON“ BZW. EN UND „HOLD“ (FESTHALTEN), MESSERPEDAL MIT DEM ABSATZ TRETEN. ZUM MÄHEN ABSATZ AUF DEM MESSERPEDAL LASSEN.

AUSSCHALTEN DES MESSERS: ABSATZ WEG VOM MESSERPEDAL ODER MESSERHEBEL AUF „OFF“ BZW. AUS.

FONCTIONNEMENT DES FREINS
POUR L'ARRÊT: APPUYEZ SUR LA PÉDALE EMBRAYAGE/FREIN.

POUR METTRE LES FREINS DE STATIONNEMENT: APPUYEZ SUR LA PÉDALE EMBRAYAGE/FREIN. SOULEVEZ LE LOQUET DU FREIN DE STATIONNEMENT ET RELACHEZ LES PÉDALES EMBRAYAGE/FREIN.

POUR RELÂCHER LES FREINS DE STATIONNEMENT: APPUYEZ SUR LA PÉDALE EMBRAYAGE/FREIN.

FONCTIONNEMENT DE LA LAME

POUR ACTIONNER LA LAME: DÉPLACER LE LEVIER EN LE MAINTENANT. APPUYEZ AVEC LE TALON. MAINTENEZ UN DE VOS TALONS SUR LA PÉDALE POUR TONDER.

POUR ARRÊTER LA LAME: RETIRER VOTRE TALON DE LA PÉDALE OU PLACER LE LEVIER SUR OFF.

REMBEDIENING
OM TE STOPPEN: DUW ONTKOPPELING/REMPEDAAL IN.

OM PARKEERREM AAN TE ZETTEN: DUW ONTKOPPELING/REMPEDAAL IN, HEF PARKEERHEFBOOM OP EN LAAT ONTKOPPELING/REMPEDAAL LOS.

OM PARKEERREM LOS TE LATEN: DUW ONTKOPPELING/REMPEDAAL IN.

MESBEDIENING

OM HET MES TE STARTEN: TREK MESHEFBOOM NAAR "ON" EN HOUD VAST. DUW OP MESPEDAAL MET HIEL. HOUD HIEL OP MESPEDAAL OM TE MAAIEN.

OM HET MES TE STOPPEN: VERWUJDER HIEL VAN MESPEDAAL OF VERPLAATS MESHEFBOOM NAAR "OFF".

AVERTISSEMENT
WARNING

POUR ÉVITER TOUT DANGER D'ACCIDENT

- LIRE SOIGNEUSEMENT TOUTS LES MANUELS ET INSTRUCTIONS FOURNIS AVEC LA MACHINE.
- ASSUREZ VOUS QUE TOUTS LES BOUCLIERS DE PROTECTION, CONTACTEURS ET AUTRES DISPOSITIFS DE SÉCURITÉ SOIENT BIEN EN PLACE ET FONCTIONNELS.
- DÉBARRASSEZ LA SURFACE À TONDER DE TOUT F.L. MÉTALLIQUE, PIERRES OU TOUT AUTRE OBJET QUI POURRAIT CAUSER DES ACCIDENTS S'ILS ÉTAIENT PROJÉTÉS PAR LA LAME.
- NE LAISSEZ JAMAIS LES ENFANTS DE MOINS DE TRENTE ANS SUR OU À PROXIMITÉ DE LA TONDEUSE PENDANT SON UTILISATION. ÉLOIGNEZ LES GENS À UNE BONNE DISTANCE DE L'ENDROIT OÙ VOUS TONDEZ.
- REGARDEZ BIEN DERRIÈRE VOUS AVANT DE FAIRE MARCHÉ ARRIÈRE.
- NE TONDEZ PAS SUR LES PENTES OU SUR QUELQUE ENDROIT OÙ LA STABILITÉ OU LA TRACTION SERAIENT DOUTEUSES. SI VOUS NE POUVEZ PAS FAIRE MARCHÉ ARRIÈRE SUR UNE PENTE NE TONDEZ PAS.
- NE TONDEZ PAS EN DEVERS SUR LES PENTES TONDEZ DE HAUT EN BAS. RALENTISSEZ ET NE FAITES PAS DE VIRAGES BRUSQUES QUAND VOUS TONDEZ SUR UNE SURFACE INCLINÉE.
- NE TONDEZ PAS SUR DES PENTES SUPÉRIEURES À 10 DEGRÉS (ÉLEVATION DE 30cm SUR UNE LONGUEUR DE 180cm).
- ÉVITEZ LES DÉMARRAGES EN CÔTÉ SI LA MACHINE STOPPE EN MOMENT UNE CÔTÉ, ARRÊTEZ LA LAME ET REDESCENDEZ LA CÔTÉ.
- ARRÊTEZ LA LAME AVANT DE METTRE LE PIED À TERRE ET DE QUITTER VOTRE SIÈGE.

ZU UNFALLVERHÜTUNG

- LESEN SIE ALLE MITGELIEFERTEN BETRIEBSANLEITUNGEN UND VORSCHRIFTEN DURCH.
- STELLEN SIE SICHER, DASS SICH SCHUTZBLECHE, BLENDEN, SCHALTER UND SONSTIGE SICHERHEITSVORKEHRUNGEN IN DER RICHTIGEN STELLUNG BEFINDEN UND BETRIEBSTÜCHTIG SIND.
- ENTFERNEN SIE DRAHT, STEINE UND SONSTIGE GEGENSTÄNDE VOR DER MÄHFLÄCHE, DIE BEI BERÜHRUNG MIT DEM MESSER VERLETZUNGEN ODER SACHSCHÄDEN VERURSACHEN KÖNNEN.
- DULDEN SIE BEIM MÄHEN KEINE KINDER UNTER 12 JAHREN AUF DEM MÄHER ODER RASCH. ALLE ANDEREN PERSONEN SOLLTEN EINEN SICHERHEITSABSTAND EINHALTEN.
- SEHEN SIE VOR DEM ZURÜCKSETZEN NACH HINTEN.
- MÄHEN SIE NICHT AN ABHÄNGEN ODER IN BEREICHEN, WO DIE STABILITÄT DES MÄHERS IN FRAGE GESTELLT WIRD. MÄHEN SEI REINE ABHÄNGE, DIE SIE NICHT RÜCKWÄRTS HINUNTERFAHREN KÖNNEN.
- MÄHEN SIE ABHÄNGE NICHT OBER, SONDERN HANGAUF- UND HANGABWÄRTS REDUZIEREN SIE DIE GESCHWINDIGKEIT UND VERMEIDEN SIE SCHARFE WENDE AN ABHÄNGEN.
- MÄHEN SIE NICHT AN HÄNGEN MIT EINEM GEFÄLLE VON MEHR ALS 10 GRAD (0,33 M HÖHE AUF 0,98 M LÄNGE).
- VERMEIDEN SIE EE, AN ABHÄNGEN HANGAUFWÄRTS ZU STARTEN, WEIL DER MÄHER AUF DER AUFWÄRTSFAHRT ANGEHALTEN WIRD, SCHALTEN SIE DAS MÄHWERK AUS, UM DEN HANG RÜCKWÄRTS HINUNTER ZU FAHREN.
- STOPPEN SIE VOR DEM ABSITZEN DAS MÄHWERK.

ATTENTION VORSICHT

LE DEFLECTEUR LATERAL OU LE BAC DE RAMASSAGE DOIVENT ÊTRE INSTALLÉS AVANT L'UTILISATION DE LA TONDEUSE.

VOR INBETRIEBSETZEN DES MÄHERS SIND AUSWURFBLECH BZW. GRASFANGVORRICHTUNG ZU BEFESTIGEN.

REMOVE BATTERY BEFORE STANDING MOWER ON END FOR MORE THAN 2 HOURS

ENTFERNEN SIE DIE BATERIE, BEVOR SIE DEN REITERMAHER FÜR MEHR ALS 2 STUDEN STELLEN

LA BATTERIE DOIT ÊTRE ENLEVÉE AVANT DE METTRE LA TONDEUSE DEBOUT POUR PLUS DE 2 HEURES

BATTERY VERWIJDEREN INDIEN U DE MAAIER VOOR MEER DAN 2 UUR RECHT OP ZET

3 LWA
100

CE
29776

WARNING

ITEM	PART NO.	DESCRIPTION
1	2-2215	DECAL, Brake Operation (German)
2	2-2216	DECAL, Brake Operation (French)
3	2-2218	DECAL, Brake Operation (Dutch)
4	2-2841	DECAL, Warning
5	2-4052	DECAL, Deflector (German & French)
6	2-9837	DECAL, Safety Instruction (German & French)
7	2-9776	DECAL, European Community
8	2-9948	DECAL, Battery Storage
9	2-3009	DECAL, European Noise Control

(DECALS CONTINUED ON NEXT PAGE)

WARNING
WAARSCHUWING

AVOID SERIOUS INJURY OR DEATH

- READ ALL MANUALS AND INSTRUCTIONS FURNISHED WITH THE MACHINES AND ATTACHMENTS.
- MAKE SURE THAT SHIELDS, GUARDS, SWITCHES, AND OTHER SAFETY DEVICES ARE IN PROPER POSITION AND ARE FUNCTIONAL.
- CLEAR MOWING AREA OF WIRE, ROCKS, AND OTHER OBJECTS THAT COULD CAUSE MAJURY IF THROWN BY BLADE.
- DO NOT ALLOW CHILDREN (PRE-TEENAGERS) ON MACHINE (EVEN WITH BLADE OFF) OR IN YARD WHEN MOWING. KEEP OTHERS SAFELY AWAY FROM THE OPERATING AREA.
- LOOK DOWN AND BEHIND MACHINE BEFORE AND WHILE REVERSING.
- DO NOT MOW ON SLOPES OR ANY AREA WHERE STABILITY OR TRACTION IS IN DOUBT. IF YOU CAN NOT REVERSE UP A SLOPE, DO NOT MOW ON IT.
- DO NOT MOW ACROSS FACE OF SLOPES. MOW UP AND DOWN. REDUCE SPEED AND AVOID SHARP TURNS ON SLOPES.
- DO NOT MOW ON SLOPES STEEPER THAN 10 DEGREES (ONE FOOT OF RISE IN SIX FEET OF LENGTH).
- AVOID UPHILL STARTS. IF THE MACHINE IS STOPPED GOING UP A SLOPE, TURN BLADE OFF AND REVERSE DOWN THE SLOPE.
- STOP BLADE BEFORE PUTTING FOOT ON GROUND OR LEAVING THE SEAT.

VERMIJDT ERNSTIGE KWETSUREN OD DOODSLAG

- LEES ALLE GEBRUIKSAANWIJZINGEN EN INSTRUCTIES DIE MET DE MACHINE EN TOEBEHOREN GELEVERD ZIJN.
- VERZEKER U ERVAN DAT ALLE BESCHERMAPPEN, SCHAKELAARS EN ANDERE VEILIGHEIDSVORZIENINGEN IN GOEDE STAAT ZIJN EN GOED WERKEN.
- VERWIJDER ALLE VOORWERPEN UIT DE MAAIZONE DIE ERNSTIGE KWETSUREN KONNEN VERDOORZAKEN ALS ZE DOOR HET MES UITGEWORPEN WORDEN.
- LAAT GEEN KINDEREN (1-12J) TOE OP DE MACHINE (ZELFS MET UITGESCHAKELD MES) OF IN DE TUIN TIJDENS MET MAAKEN EN HOUDT ANDEREN OP VEILIGE AFSTAND.
- KIJK BENEDE EN ACHTER U ALS U ACHTERUITRIJDT.
- MAAI NIET OP HELLINGEN VAN WAAR OOK ALS DE STABILITEIT VAN DE MACHINE TWIJFELACHTIG IS. RIJNT U ACHTERUIT NIET DE HELLING OP MAAI DAN NIET.
- MAAI EEN HELLING NOOIT IN DE LENGTE MAAR OP EN AFWAARTS. MATIG UW SNELHEID EN VERMIJDT KORTE DRAAIBEWEGINGEN.
- MAAI GEEN HELLINGEN STEILER DAN 10 GRADEN (0,33 METER HOOG BIJ 0,98 METER LANG).
- VERMIJDT OM BERGPWAARTS TE STARTEN. VALT DE MOTOR STIL BERGPWAARTS, SCHAKEL DAN HET MES UIT EN LAAT U NAAR BENEDE ZAKKEN.
- SCHAKEL HET MES UIT ALVORENS EEN VOET OP DE GROND TE ZETTEN OF DE ZETEL TE VERLATEN.

- ⊘ De machine niet gebruiken zonder de grasopvangzak of de beschermkap
- ⊘ Do not operate without entire Grass Catcher or Guard in place
- ⊘ Ne pas utiliser sans le bac de ramassage ou la projection en place
- ⊘ Betreiben Sie dieses Gerät nicht ohne Grasfangkorb oder Abdeckschutz

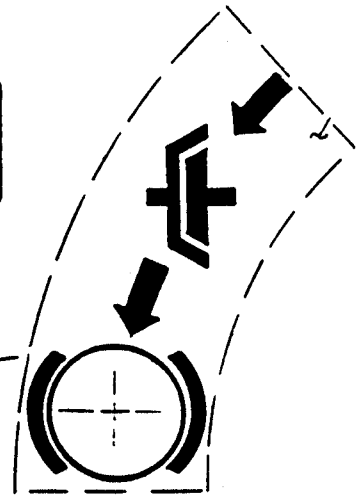

1994
29878

1995
28515

CAUTION

POSITIVE (+) BATTERY POST MUST BE TO REAR TO PREVENT ARCING AND POSSIBLE EXPLOSION OR FIRE. USE ONLY SNAPPER REPLACEMENT BATTERY TO AVOID ACID DAMAGE.

ATTENTION

LA COSSE POSITIVE (+) DE LA BATTERIE DOIT SE TROUVER AU FOND DU LOGEMENT POUR EVITER LES ÉTINCELLES. L'EXPLOSION OU L'INCENDIE UTILISER EXCLUSIVEMENT DES BATTERIES D'ORIGINE SNAPPER POUR EVITER LES RISQUES LIÉS A L'ACIDE

ACTUNG

UM VERÄTZUNGEN: FEUER ODER MÖGLICHEN EXPLOSIONEN VORZUBEUGEN, MUSS SICH DER PLUSPOL DER BATTERIE HINTEN BEFINDEN BENUTZEN SIE AUSSCHLIESSLICH ORIGINAL SNAPPER BETTERIEN UM SÄURESCHÄDEN ZU VERMEIDEN.

WAARSCHUWING

POSITIEVE (+) BATTERIJKLEM MOET ZICH ACHTERHAN BEVINDEN OM KORTSLUITING EN MOGELIJK ONT-PLOFFINGS GEVAAR OF BARND TE VOORKOMEN

OM BATTERIJZUUR SCHADE TE VOORKOMEN ALLÉEN SNAPPER BATTERIEN GEBRUIKEN.

PATENTED

AUTOMATIC BLADE STOP

STOPS BLADE - NOT ENGINE

25
INCH
PATENTED HI-VAC

28
INCH
PATENTED HI-VAC

33
INCH
PATENTED HI-VAC

ITEM	PART NO.	DESCRIPTION
10	2-9838	DECAL, Safety Instruction (English & Dutch)
11	2-9839	DECAL, Deflector Caution (English & Dutch)
12	2-9947	DECAL, Battery Caution
13	2-4072	DECAL, Auto Blade Stop
14	2-9784	DECAL, Do Not Operate...
15	2-9878	DECAL, Year Of Manufacture (1994)
16	2-3992	DECAL, 25 Inch (Hi-Vac)
17	2-3996	DECAL, 28 Inch (Hi-Vac)
18	2-2991	DECAL, 33 Inch (Hi-Vac)
19	2-8514	DECAL, Clutch - Brake
20	2-8515	DECAL, Year Of Manufacture (1995)

CAUTION/OPGEPAST

DEFLECTOR MUST BE FASTENED DOWN OR GRASS CATCHER INSTALLED BEFORE OPERATING MOWER.

DEFLEKTOR NEERLATEN OF GRASOPVANGZAK AANBRENGEN ALVORENS DE GRASMAAIER TE STARTEN.

DECALS

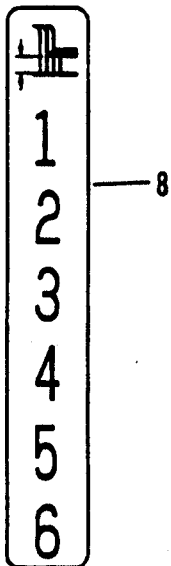
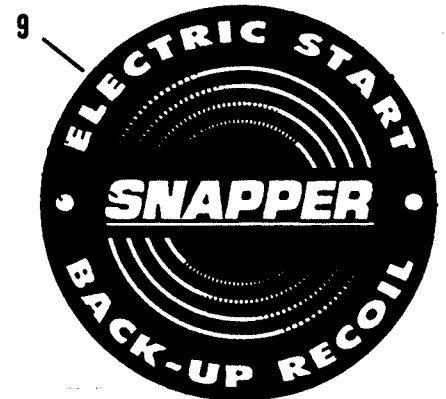
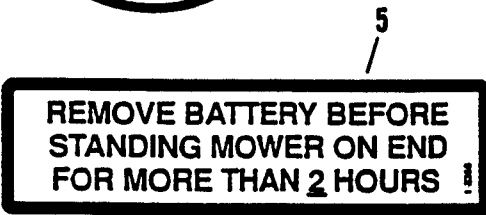
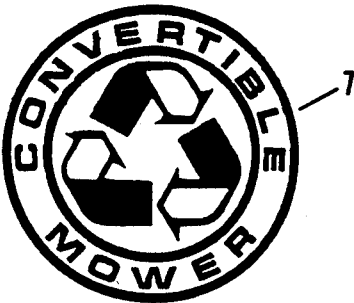
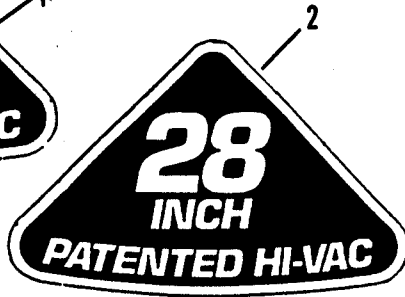

ITEM	PART NO.	DESCRIPTION
1	2-3992	DECAL, 25 Inch
2	2-3996	DECAL, 28 Inch
3	2-9453	MEDALLION, Sam
4	2-2991	DECAL, 33 Inch
5	1-2358	DECAL, Battery
6	1-6974	SNAPPER, (Molded Logo)
7	3-4134	LOGO, Convertible (Silver) (25" Models)
--	2-4068	LOGO, Convertible (Teal) (28" Models)
--	2-4067	LOGO, Convertible (Blue) (33" Models)
8	2-6419	DECAL, Height of Cut
9	2-3980	DECAL, Back-Up Recoil (33" Kohler Models)
10	2-3982	DECAL, OHV (33" Kohler Models)
--	2-9077	DECAL, Year Of Manufacture (1996) (Not Shown)
--	2-3998	DECAL, Bumper Stripe (Teal) (Not Shown)

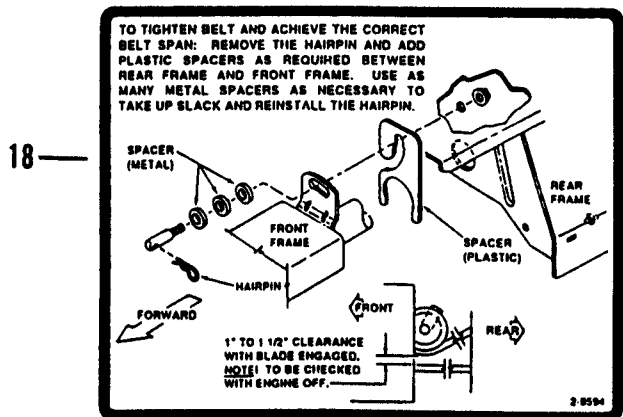
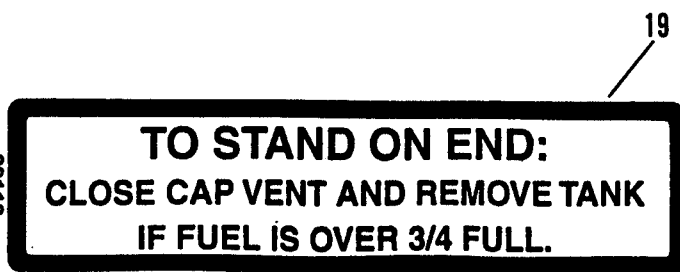
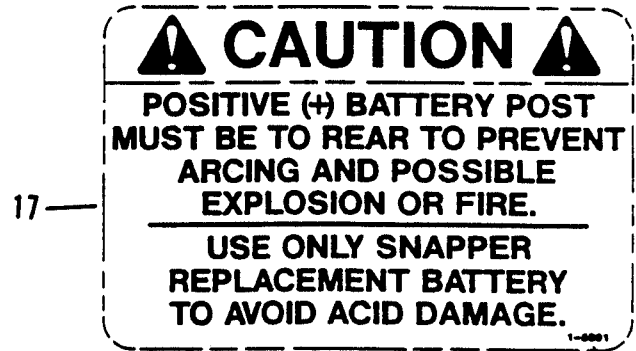
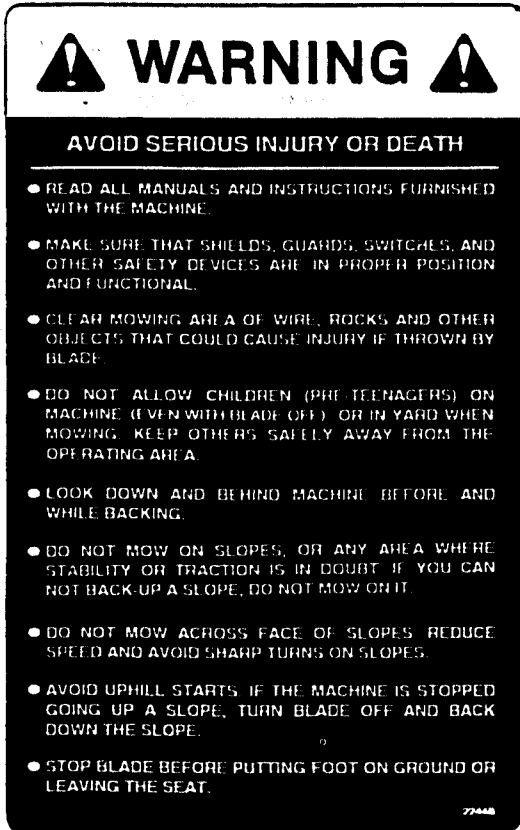
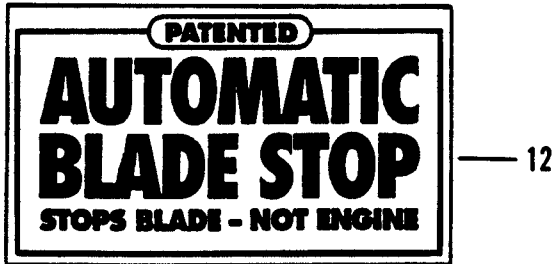
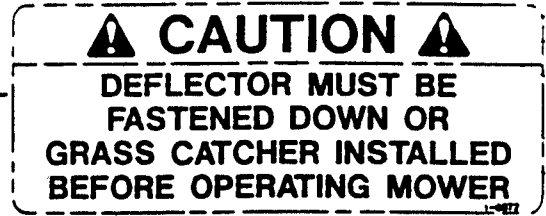

29113

ITEM	PART NO.	DESCRIPTION
11	2-3983	DECAL, 14 HP (33" Kohler Models)
12	2-4072	DECAL, Auto Blade Stop (Point of Purchase Decal)
13	2-2448	DECAL, Safety Instruction Warning
14	1-6972	DECAL, Caution Deflector
15	1-6973	DECAL, Caution Rotating Blades
16	1-3010	DECAL, Danger
17	1-5691	DECAL, Caution Battery
18	2-9594	DECAL, Belt Adjustment (used on 25" models)
*	2-8097	DECAL, SR825
*	2-9669	DECAL, SR928
*	2-7788	LOGO, SR1333 (Molded Logo)
*	2-7782	LOGO, SR1433 (Molded Logo)
*	2-4042	DECAL, Banner Stripe (Silver) (25" Models)
*	2-4043	DECAL, Banner Stripe (Teal) (28" Models)
*	2-4001	DECAL, Bumper Stripe (Silver) (25" Models)
*	2-4004	DECAL, Bumper Stripe (Blue) (33" Models)
19	2-9113	DECAL, Caution Fuel
20	1-4000	BOOK, Safety
21	1-5534	BOOKLET, Snapper Versus Dirt
22	2-8605	OPERATOR'S Manual/Safety Instruction

***NOTE: These items not shown. The description is the visual identification.**

SNAPPER®

5 - 2 YEAR LIMITED WARRANTY

COMPONENT PARTS - 5 YEARS

For five (5) years from purchase date for original purchaser's residential non-commercial* use, Snapper, through any Snapper dealer will replace free of charge any part or parts found upon examination by the factory to be defective in material or workmanship or both.

ENGINE - 2 YEARS

The engine on this product is warranted by the engine manufacturer for two (2) years for the original purchaser's non-commercial* use. (See engine manufacturer's warranty statement for details.)

BATTERIES

Batteries are warranted separately and have one (1) year prorated warranty with a ninety (90) day free replacement period.

DISCLAIMER OF WARRANTIES

Implied warranties including those of merchantability and fitness for a particular purpose, are limited to five (5) years from purchase date for the original purchaser's residential, non-commercial use, for ninety (90) days from purchase date for the original purchaser's commercial, rental, or other non-residential use, and to the extent permitted by law, any and all implied warranties are excluded. This is the exclusive remedy. Liabilities for consequential damages, under any and all warranties are excluded.

Some states do not allow limitations on how long an implied warranty lasts, or do not allow the exclusion or limitation of incidental or consequential damages, so the above limitation or exclusion may not apply to you.

All transportation cost incurred by the purchaser in submitting material to a Snapper dealer for replacement under this warranty must be paid by the purchaser.

This warranty does not apply to parts that have been damaged by accident, alteration, abuse, improper lubrication, normal wear (things such as belts, blades, driven disc or any other normal wear item). This warranty does not cover tune-ups or other adjustments required in the normal use of the product.

There is no other express warranty.

This warranty gives you specific legal rights, and you may also have other rights which vary from state to state.

*Any use other than on the purchaser's residential lawn constitutes commercial use.

WARNING: THE USE OF REPLACEMENT PARTS OTHER THAN GENUINE SNAPPER PARTS MAY IMPAIR THE SAFETY OF SNAPPER PRODUCTS AND WILL VOID ANY LIABILITY AND WARRANTY BY SNAPPER ASSOCIATED WITH THE USE OF SUCH PARTS.

IMPORTANT: Please fill out the attached SNAPPER Product Registration Card immediately and mail to: SNAPPER, 535 Macon Rd., McDonough, Ga. 30253

Safety Instructions & Operator's Manual for

SNAPPER®

**SERIES 15 REAR ENGINE
RIDING MOWER MODELS**

E250815BE

E280915BE

E331315BE

E331415KVE

▲WARNING: The engine exhaust from this product contains chemicals known to the State of California to cause cancer, birth defects or other reproductive harm.

SNAPPER McDonough, GA., 30253 U.S.A.

MANUAL No. 2-8605 (I.R. 2/96)