

Safety Instructions & Operator's Manual

SNAPPER[®]



WALK BEHIND MOWERS

21" HI-VAC --SERIES 7

21357B
D21357B
R21357B

P21357B
DP21357B
RP21357B

*Thank you for buying a SNAPPER product! Before operating your mower, read this manual carefully and pay particular attention to the **Important Safety Instructions** on page 2. Remember that mowers and all power equipment can be dangerous if used improperly and keep in mind that safety requires careful use in accordance with the instructions andcommon sense!*

This manual covers SNAPPER 21" HI-VAC Series 7 (last numeral in the five digit model designation) walk behind mowers. A letter "D" prefix designates side discharge models. Models with an "R" prefix are recycling mowers. Those having a "P" prefix are self-propelled. Models with a "B" suffix are Briggs & Stratton powered. Differences are pointed out wherever pertinent throughout the manual.

SNAPPER POWER EQUIPMENT
McDonough, GA., 30253 U.S.A.



IMPORTANT SAFETY INSTRUCTIONS

WARNING: Failure to comply with the following instructions may result in serious injury to the operator or other persons. The owner of the mower must understand these instructions and, furthermore, must allow only persons who understand these instructions to operate the mower. Each person operating the mower must be of sound mind and body and must not be under the influence of any substance which might impair vision, dexterity, or judgement. If you have any questions pertaining to your mower which your dealer cannot answer to your satisfaction, call or write the Customer Service Department at SNAPPER POWER EQUIPMENT, McDonough, Georgia, 30253 (Phone 404-957-9141).

TRAINING

1. Read this Manual carefully and question your dealer if something is not clear. Should the dealer be unavailable or unable to answer to your satisfaction, write or call our Customer Service Department at the factory. Be thoroughly familiar with the controls and proper use of the equipment.
2. **DO NOT** allow children in yard when mower is operated.
3. **DO NOT** allow pre-teenage children to operate mower.
4. Allow only responsible teenagers with mature judgement to operate mower and only under close supervision.
5. Keep the area clear of all persons, particularly small children, and pets.

PREPARATION

1. Never operate mower without proper guards, plates, safety switches, or other safety protective devices in place and properly connected. Inspect to determine that these safety devices are installed properly, are in good repair, and operate properly. If the condition or operation of these devices are questionable, they must be repaired or replaced before using the mower.
2. Thoroughly inspect the area where the mower is to be used and remove all stones, sticks, wire, bones and other foreign objects. Also note the location of holes, stumps, and other possible hazards.
3. Do not operate mower when barefoot or wearing open sandals. Always wear substantial footwear and long pants.
4. Fill gasoline tank before starting engine. Use approved gasoline container. Do not smoke near open gasoline container. Do not fill gasoline tank indoors or when engine is running. Allow engine to cool for at least ten minutes before refilling. Wipe off any spilled gasoline before starting engine. Do not run engine indoors.
5. Make sure that the traction drive clutch control is disengaged before starting engine.
6. Never attempt to make a cutting height adjustment while the engine is running.
7. When mowing over rough ground or in tall grass, mower must be set in highest cutting position.
8. Mow only in daylight or in good artificial light.
9. Never operate mower in wet grass. Always be sure of your footing; keep a firm hold on the handle and walk; never run.
10. Do not operate mower without the grass bag and adapter or the side discharge chute in place.

OPERATION

1. Do not change engine governor settings or overspeed engine.
2. Do not put hands or feet near or under rotating parts. Keep clear of discharge area while engine is running.
3. Stop engine when crossing gravel drives, walks, or roads, and under any conditions where thrown objects might be a hazard.
4. After striking a foreign object or if mower vibrates abnormally, stop the engine, disconnect and secure spark plug wire. Inspect the mower for any damage and repair the damage.
5. Stop blade and engine whenever you leave the operating position behind the handle for any reason, including clearing grass, emptying grass bag and making any adjustments, repairs, or inspections.
6. Before cleaning, repairing or inspecting, make certain blade and all moving parts have stopped. Disconnect and secure spark plug wire away from plug to prevent accidental starting.
7. Stop engine and wait until the blade comes to complete stop before removing grass bag and/or clearing grass.
8. Mow across slopes, never up-and-down. Exercise caution when changing directions on slopes. Do not mow steep slopes or other area where stability or traction is in doubt.

MAINTENANCE AND STORAGE

1. Keep all nuts, bolts, and screws tight to be sure mower is in safe operating condition.
2. Never store mower with gasoline in tank inside of a building where fumes may reach an open flame or spark. Allow engine to cool before storing in any enclosure.
3. To reduce fire hazard, keep mower free of grass, leaves or excessive grease.
4. Check grass bag assembly frequently for wear or deterioration. Replace with new bag if loose seams or tears are evident. Replace slider or bag adapter if broken or cracked.
5. Have your mower inspected and serviced each year by an authorized SNAPPER dealer. Determine if any additional devices are available which might upgrade the safety of your mower.
6. Factory specified SNAPPER replacement parts must be used to assure adequate protection against injury.

INTRODUCTION

This manual covers **SNAPPER** Series 7 walk behind 21" push and self-propelled mowers. Series 7 models can (with the proper attachments) discharge chopped and shredded mixed clippings (**RECYCLING KIT**), bag clippings (**GRASS BAG**), or vacuum thatch (**THATCHERIZER & GRASS BAG**), or vacuum clippings and leaves (**SNAPPERIZER & GRASS BAG**).

The **THATCHERIZER** is recommended for self-propelled models. For more complete descriptions, refer to the **POPULAR ACCESSORIES** section.

KNOW AND OBSERVE THE IMPORTANT SAFETY INSTRUCTIONS WHEN OPERATING THE MOWER!

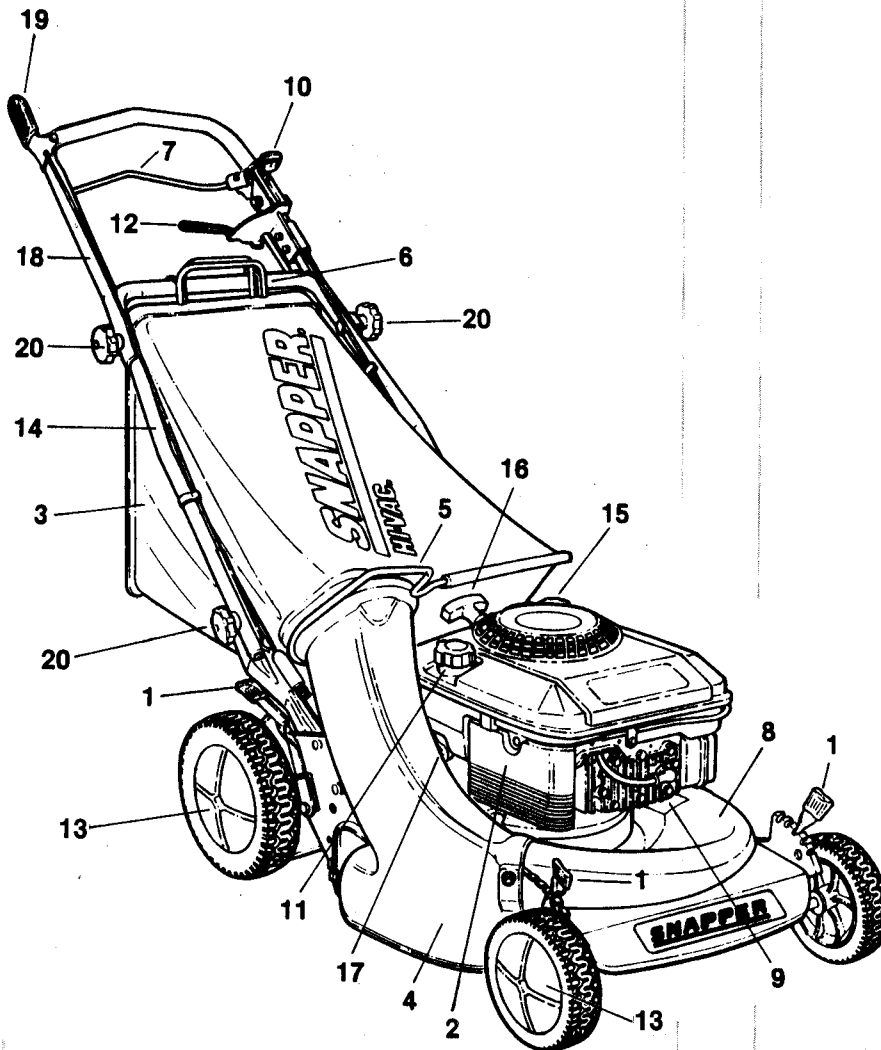

FIG. 1-ROPE START
LOCATION OF CONTROLS/FEATURES

OPERATING PROCEDURE

Know how to stop the mower in preparation for possible emergencies **BEFORE** the first start-up!

For easier starting, move the mower to an area where the blade can turn freely without being restricted by tall grass.

The engine (and blade) is stopped by releasing the **BLADE CONTROL (7)** or by pulling the **ENGINE CONTROL lever (10)** rearward to the **STOP** position. On self-propelled models, releasing the **WHEEL DRIVE control (19)** stops the forward movement of the mower. Refer to **FIG. 1** for locations of controls.

OPERATING/SERVICE POINTS

- 1 ADJUSTING LATCH (HEIGHT)
- 2 AIR BREATHER (COVER)
- 3 BAG
- 4 BAG ADAPTOR
- 5 BAG CONNECTOR
- 6 BAG WIRE SUPPORT
- 7 BLADE CONTROL
- 8 DECK
- 9 ENGINE
- 10 ENGINE CONTROL LEVER
- 11 FUEL FILLER CAP
- 12 GROUND SPEED CONTROL
- 13 HUB CAP
- 14 LOWER HANDLE
- 15 OIL FILLER (DIPSTICK)
- 16 ROPE START HANDLE
- 17 FUEL SHUT-OFF VALVE
- 18 UPPER HANDLE
- 19 WHEEL DRIVE CONTROL
- 20 KNOB
- 21 DECK COVER (RECYCLING)

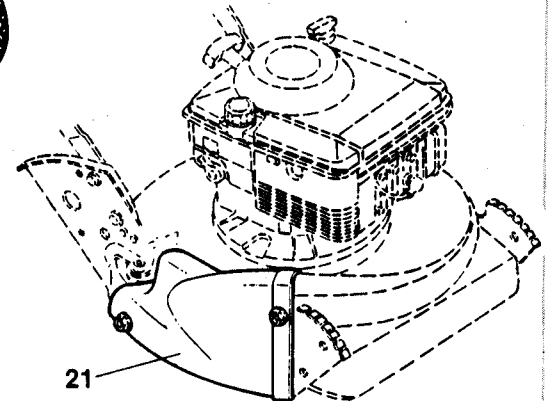

FIG. 1-A
RECYCLING
DECK COVER DETAIL

PRE-START CHECKS

Prior to each start-up, check/service as needed:

- **CHECK** guards, BAG (3), BAG ADAPTOR (4), DECK COVER (21) or side discharge chute for proper position and tightness.
- **NOTE:** The "tab" on the inside rear edge of the adapter or side chute must push the interlock spring in toward the center of the mower. If the tab is improperly installed, the engine **CAN NOT** be started.
- **CLEAN** surfaces to remove dust, dirt, and clippings - particularly from the cooling air intake screen on engine to prevent overheating.
- **CHECK** oil level in 4-cycle engines and add oil as needed to bring the level up to but not over the dipstick (15) "FULL" mark. Refer to FIG. 2.
- **CHECK** cutting height and adjust as needed, to suit the prevailing grass conditions. Refer to FIG. 5.
- **CHECK** fuel level in tank after pushing mower outdoors where fumes will safely dissipate.

FIG. 2-DIPSTICK LOCATION

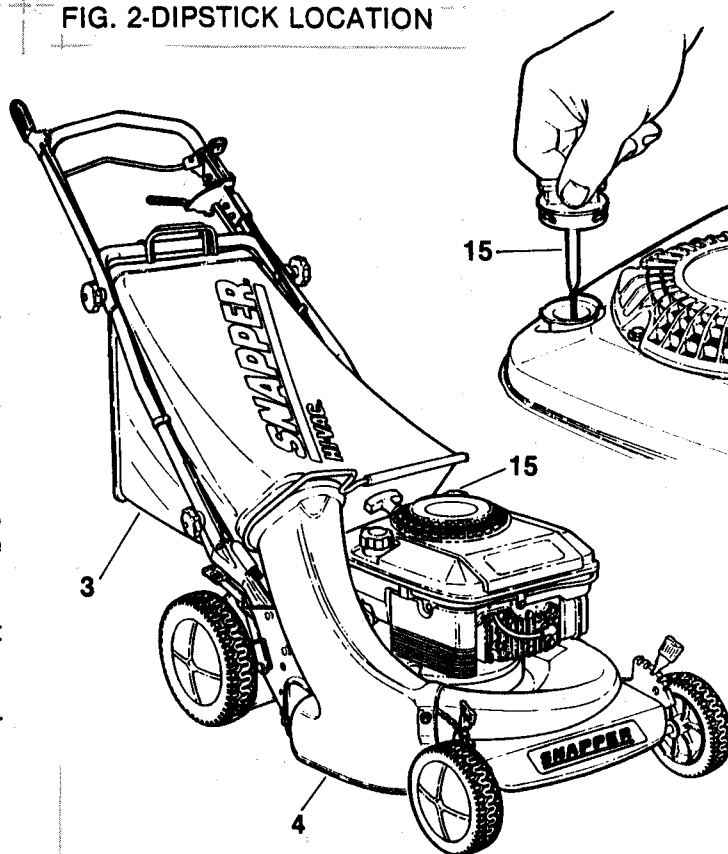

STARTING/STOPPING ENGINE

NOTE: Stop the engine (and blade) by releasing the **BLADE CONTROL** or by pulling the **ENGINE CONTROL** rearward to **STOP** position.

Open **SHUT-OFF VALVE** (17) if the engine is so equipped (refer to FIG. 1). Push the primer button (if so equipped) if the engine is cold.

ROPE START:

1. Move **ENGINE CONTROL** lever to **CHOKE** position.
2. Hold **BLADE CONTROL** (7) firmly against **UPPER HANDLE** (18) - otherwise the engine will not start! Refer to FIG. 3.
3. Place left foot on top of left rear tire with toes pointing forward.
4. Bend at waist to reach **ROPE START HANDLE** (16) and straighten up as you pull handle - using back muscles more than arm muscles.
5. Continue pulling **ROPE START HANDLE** until the engine starts. Guide rope slowly back into engine shroud to prevent rope breakage which could result if the handle is allowed to snap back. Continue holding the **BLADE CONTROL** while moving around behind the **UPPER HANDLE** to the Operator's position.

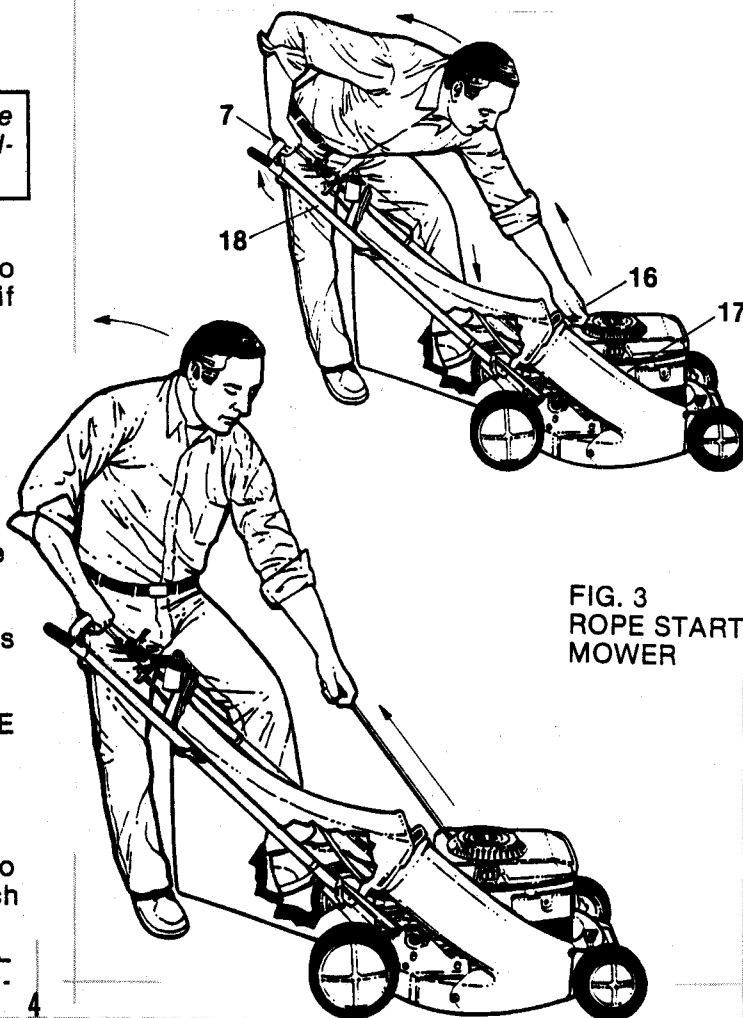

FIG. 3
ROPE START
MOWER

CUTTING HEIGHT ADJUSTMENT

ALWAYS STOP THE ENGINE AND WAIT UNTIL THE MOWER'S BLADE STOPS COMPLETELY BEFORE RE-ADJUSTING CUTTING HEIGHT!

To re-adjust mower cutting height, pull each of the four height ADJUSTING LATCHES (1) outward toward the wheel and then slide into the desired notch. Set both latches on one side and then set the two on other side into corresponding notches. When setting the rear latches into LOWER notches, raise the rear wheels off the ground to ease procedures.

It is recommended that no more than 1/3 the height be cut from the grass.

EXAMPLE: If the grass is 4" tall, set the four ADJUSTING LATCHES (1) in notch 5 (the highest blade setting) which will leave the grass at approximately 3" tall after cutting - well within the 1/3 off limit. If you prefer shorter grass, wait a few days before recutting at a lower setting. If cut short too frequently, the root system will be more subject to burning, due to energy being expended toward the development of new leaf structures rather than the necessary development and reinforcement of a good healthy root system!

FIG. 4
CUTTING HEIGHT
ADJUSTMENT

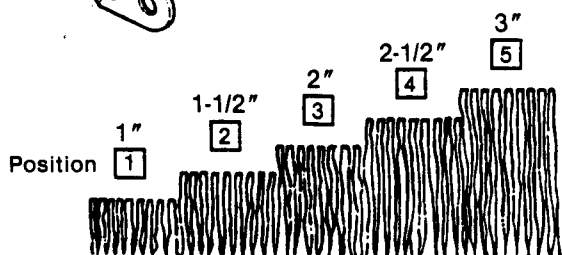
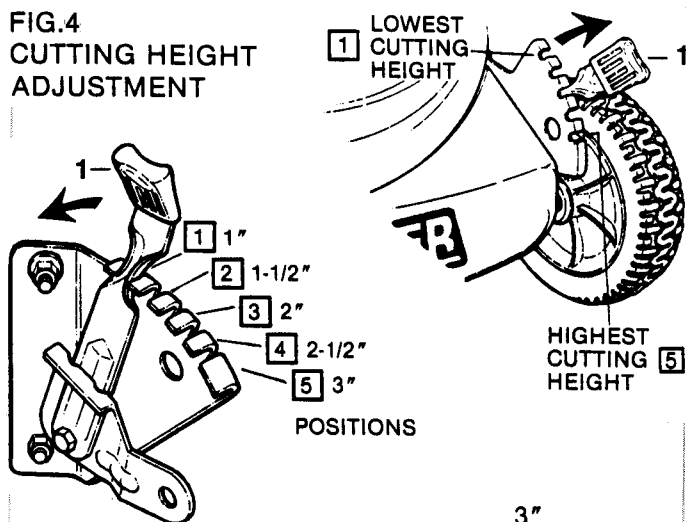

FIG. 5-CUTTING HEIGHT SETTINGS

NOTE: The highest cutting position is attained with the four latches set in notch 5. The lowest cutting position is with latches set in notch 1. Refer to FIG. 4.

RECYCLING OPERATION

For best results when recycling, set the cutting height in notch 5 (highest blade setting) or notch 4 and mow with the engine speed control in fastest speed setting. Operate the mower at slowest ground speed to allow fine chopping of the clippings or leaves. The grass must be dry. If the grass is extremely dense, set the front height adjusters one notch lower than the rear adjusters to raise the front of the deck. Experiment with deck settings to achieve best recycling.

WARNING: DO NOT operate mower without the recycling cover installed on the mower deck! If the cover is removed for side discharging or bagging, always install the proper side discharge chute or bag adapter and grass bag. The special blade provided on a recycling model does not have to be replaced for side discharging or bagging grass.

If allowed to grow too tall, the lower portion (which will then be shaded) will discolor.

During dry seasons, allow the grass to grow taller than normal. Refer to FIG. 5.

NOTE: Following the use of a dry-type fertilizer, it is recommended that the lawn be sprinkled BEFORE using the mower - to avoid vacuuming up the fertilizer.

MOWING/VACUUMING HINT: The mowing deck should be level when bagging.

Changing your mowing pattern from time to time creates a smoother cut lawn. Finely chopped clippings add nutrients to the soil-promoting grass growth! However, if accumulation becomes too heavy, matting can develop and "thatch" forms and prevents breathing, holds excessive moisture, and can destroy root structure! The SNAPPER Thatch-erizer Kit #6-0476 can prevent the development of thatch. Dislodged thatch can be vacuumed with your mower if it is equipped with the grass bag. If your SNAPPER is side discharge equipped, it can be easily converted to a bagger and back to a side discharge unit as often as desired! Refer to the ACCESSORIES section for kits available for your mower!

HUBCAP REMOVAL/INSTALLATION- PLASTIC WHEEL

Grasp the tire and gently pry the hubcap from the wheel hub. To reinstall, align the three notches (in underside of hubcap) with the corresponding three ribs on front of wheel, then snap into place.

HANDLE HEIGHT ADJUSTMENT

To raise or lower handle (14), loosen the adjusting locknuts (A) on both sides of handle shown in FIG. 5-A. Reset handle to desired position and re-tighten the locknuts.

MOWING PROCEDURE

Set the ENGINE CONTROL lever (10) in the fast (F) position for thick grass, *AND* slow down (reduce "Ground Speed") *OR* narrow the cut to less than the full blade width.

NOTE: It is recommended that the ENGINE CONTROL lever be set in the "FAST" position (higher RPM's when recycling).

On self-propelled models, set the GROUND SPEED CONTROL lever (12) in the desired setting and then grasp the WHEEL DRIVE CONTROL (19) and hold against the UPPER HANDLE (18) to engage clutch. To stop the mower's forward movement, release the WHEEL DRIVE CONTROL - the mower can then be pushed forward or pulled for trimming. Experiment and adjust the ENGINE CONTROL lever and the GROUND SPEED CONTROL until the mower functions best for your turf conditions. The speed of forward movement can be varied while the mower is moving by changing the GROUND SPEED CONTROL setting as desired. Remember - BLADE CONTROL (7) engages the blade.

NOTE: When mowing down-hill, use a "low" setting on the GROUND SPEED CONTROL lever, and brake by engaging and disengaging the WHEEL DRIVE CONTROL (CLUTCH).

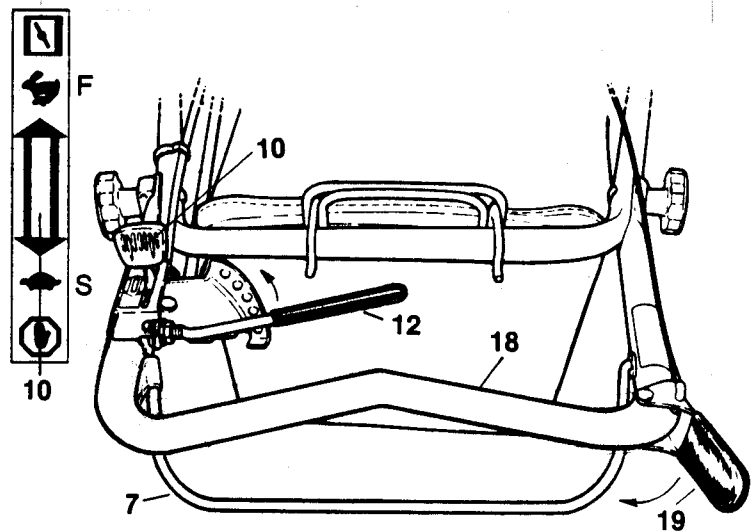
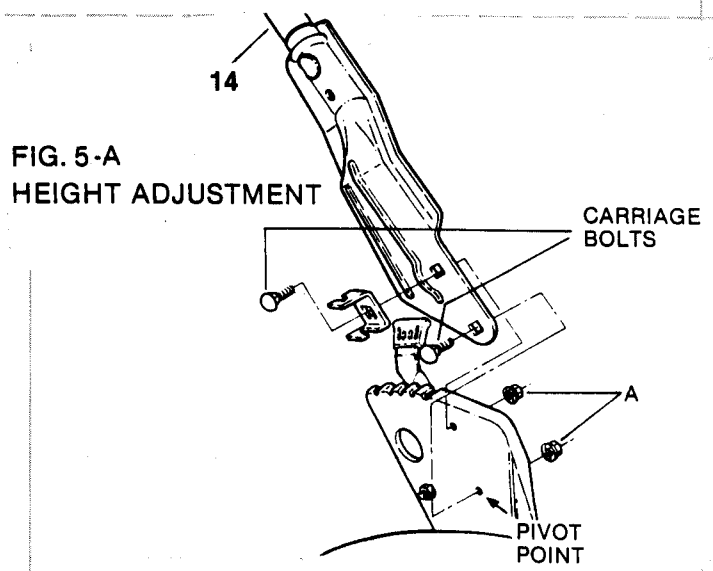

EMPTYING GRASS BAG

When the grass bag becomes full, stop engine and lift the BAG WIRE SUPPORT hooks (6) up over the LOWER HANDLE (14) and then lift the BAG CONNECTOR (5) off the adaptor flange and continue lifting while moving the bag forward until it clears the mower. To empty the bag, raise the connector end up and release the handle of the door flap. Shake the bag back and forth to dump the clippings. Refer to FIG. 7.

To re-install the bag, slide the BAG CONNECTOR down over the adapter flange, then lower the BAG WIRE SUPPORT hooks onto the LOWER HANDLE.

TO EMPTY INTO TRASH BAG: After removing the grass bag from the mower, place CONNECTOR end on ground, open door flap, slip a trash bag over the end (BAG WIRE SUPPORT end), and then turn the mower bag over so that the large opening is inside trash bag. Lift bag - by the CONNECTOR and door handles and shake until clippings are dumped into the trash bag.

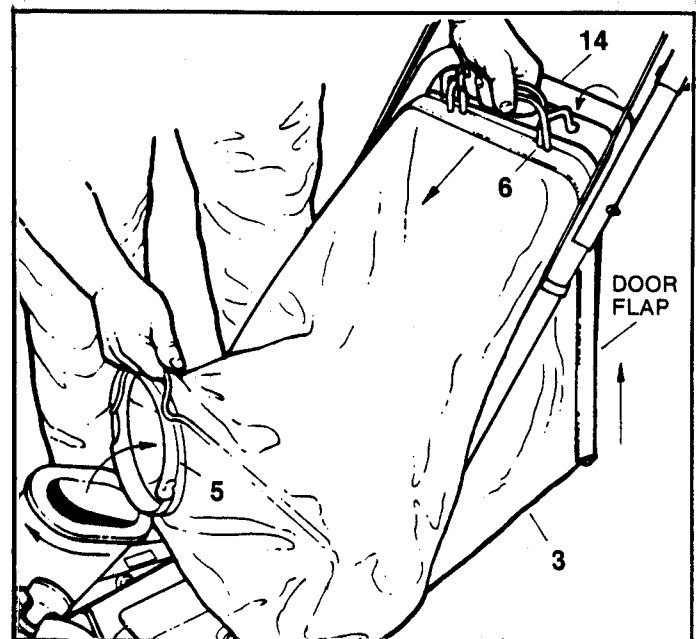

FIG. 7-EMPTYING GRASS BAG

SERVICE PROCEDURE

Your **SNAPPER** mower requires very little service, however, it is important that the engine be serviced at the intervals specified in the engine manual furnished with your mower.

To retain the integrity of your mower, only use Genuine **SNAPPER** Replacement Parts.

By returning your mower to an Authorized **SNAPPER** Dealer on a yearly basis for inspection and addition of any new devices to upgrade your mower, the reliability of the unit's functions will be assured.

Check the yellow pages under **LAWN MOWERS** for the nearest **SNAPPER** Dealer. Always mention the model and serial number of your mower when contacting the dealer for information, parts, or service.

LUBRICATION SCHEDULE

• **ENGINE:** Change oil every 25 hours as specified in engine manual; check oil level before each use.

• **TRANSMISSION (on the self-propelled models):** The transmission is filled with 4 ounces of **SNAPPER** "00" grease at the factory and under normal usage, will not require additional grease. It is recommended that plug (A) be removed after every 25 hours of operation, and a visual determination of the lubrication condition of the transmission be made. If grease IS NOT visible on the **INPUT GEAR** (the small gear below the plug opening), add a small amount of **SNAPPER** "00" grease. Reinstall the plug (A) after servicing the transmission.

SNAPPER "00" grease is available in a convenient squeeze container (Part No. 6-1017) at your **SNAPPER** Dealer.

CUTTING BLADE SERVICE

WARNING: Always disconnect the spark plug wire and secure the end away from the plug before inspecting/servicing the blade, to prevent unintentional start-ups.

Inspect blade at frequent intervals for tightness and condition.

Refer to FIG. 9 for blade condition. Replace the blade if it is badly chipped, bent, noticeably out of balance, or has a notch worn in either tip - as shown in example B.

The B wear pattern occurs more rapidly under sandy soil conditions and appears between the flat surface and upturned "lift" lip at each end of blade tip.

WARNING: Never operate the mower with a blade worn to the extent shown in example C - the "tip" could fly off and cause personal injury or property damage.

WARNING: Always disconnect the spark plug wire from the spark plug when inspecting/servicing the mower - to prevent unintentional engine start-ups.

NOTE: When tipping the mower to work on the underside, always tilt the mower with the spark plug UP to prevent flooding the engine with gasoline and/or oil which would cause hard starting after servicing.

For engine parts/service, check the yellow pages under the heading **ENGINES** - gasoline, for the nearest engine manufacturer's dealer.

OIL PLUG-DRAIN (UNDER DECK)

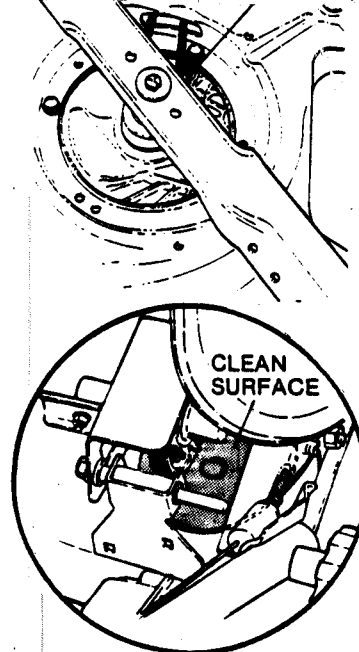
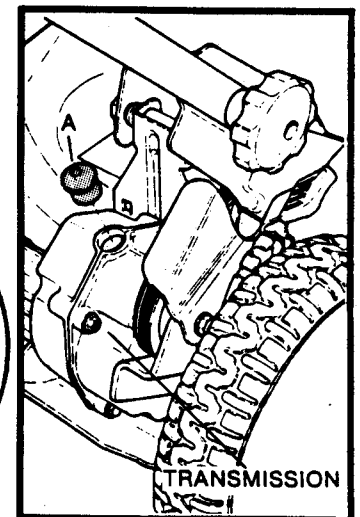

FIG. 8
TRANSMISSION
PLUG A



CAUTION: DO NOT spill oil on the surface of drive disc (on self-propelled models).

BE CAREFUL: AVOID CUTTING YOURSELF ON A SHARP BLADE! Wear gloves to protect your hands while handling the blade.

WARNING: DO NOT operate the mower without the side discharge chute, adaptor/bag, or deck cover installed and properly secured!

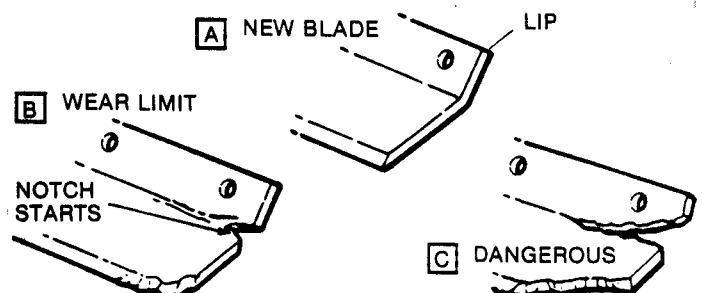

FIG. 9-BLADE WEAR PATTERNS

When the blade's cutting edges have become dull (while in otherwise good condition), sharpen on a grinding wheel at an angle of 22 to 28 degrees. The cutting surface (on each end) should extend inward about 3-1/2" from the tip. After sharpening, check the blade for balance - a blade "out of balance" will cause excessive vibration. Re-balance as required.

Re-install the blade with the components in proper sequence as shown in FIG. 10.

DO NOT substitute any components! Make sure the flange on each side of blade (at the mounting hole) fits over the edge of the blade drive hub (A). Tighten the blade retaining capscrew (B) to **30 FOOT POUNDS TORQUE**.

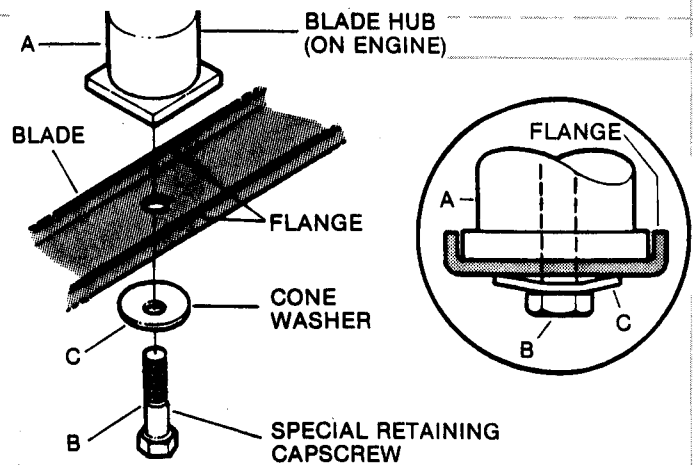

FIG. 10 - BLADE RETENTION DETAIL

CLUTCH LINKAGE (SELF-PROPELLED)

The vinyl (tube type) cover (A) should always conceal outer (B) and inner (C) clutch cable springs. The spring combination connects the clutch cable to the clutch idler components (refer to FIG. 11). The cover (A) prevents accumulation of dirt on the springs and eliminates the possibility of their wearing a hole through a grass bag.

ADJUSTMENT: Should excessive pressure be required to hold the WHEEL DRIVE CONTROL lever (19) against the UPPER HANDLE (18), spring adjusting is needed! Refer to FIG. 11.

When properly adjusted, there should be 1/16" to 1/8" clearance between the INSIDE of spring (B) hook and the INSIDE of the clutch cable "eye". Stop the engine and release the WHEEL DRIVE CONTROL lever/and pull back cover (A) to check clearance.

To adjust, unhook springs from cable (at "eye") and rotate springs in opposite directions and re-hook to cable and check clearance. Repeat procedure if needed.

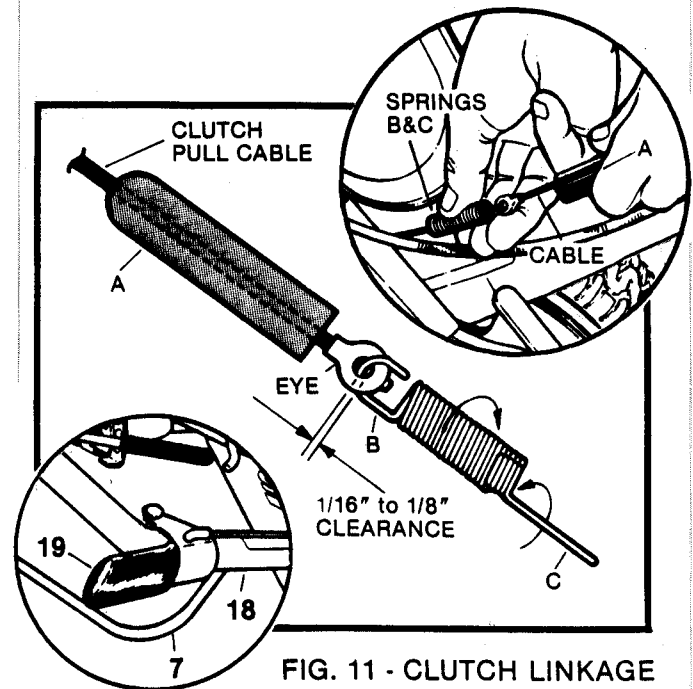

FIG. 11 - CLUTCH LINKAGE ADJUSTMENT

If the WHEEL DRIVE CONTROL lever fails to "snap" back when released, check for binding at the cable holding clip located on side of handle - it should be about 5" below the upper handle and permit the cable to slide freely. Refer to FIG. 11-A.

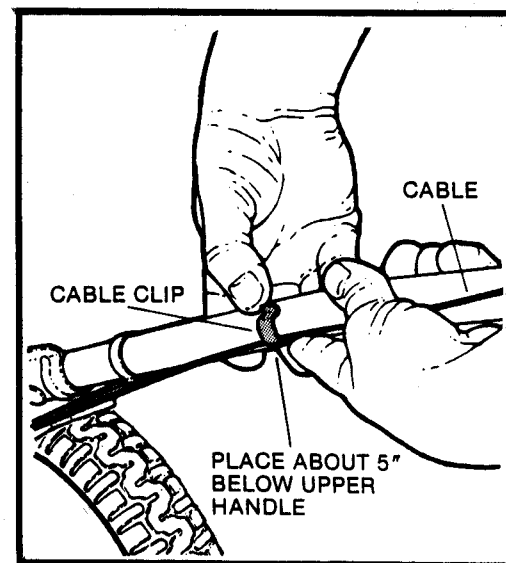

FIG. 11-A - CABLE CLIP

DRIVEN DISC SERVICE

If the mower does not pull properly, refer to FIG. 12, and check for the following:

- Grease on drive disc (C)-causing slippage.
- Broken or disconnected DRIVE SPRING (D) (also refer to FIG. 14).
- Driven disc rubber ring (B-1) worn - not contacting drive disc (C) properly.
- Driven disc (B) out of adjustment
- Worn belts

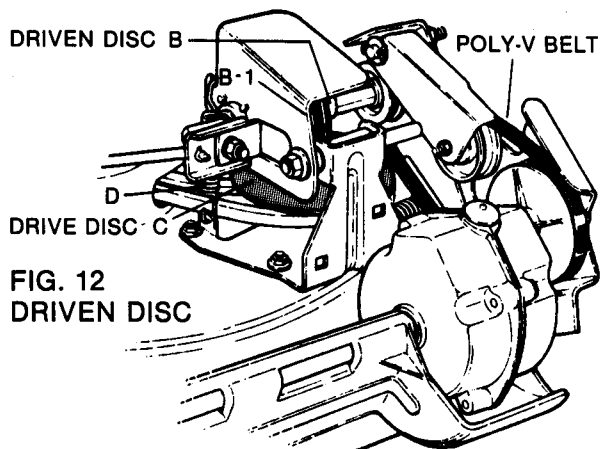

FIG. 12
DRIVEN DISC

If the clutch is properly adjusted and the belts are in good condition, service the drive system as follows:

DRIVEN DISC ADJUSTMENT: Stop the engine and shift the GROUND SPEED CONTROL (12) into the highest setting. The CENTER of driven disc should be $1/8"$ to $1/4"$ from the EDGE of the drive disc as shown in FIG.13. To re-adjust, loosen connector hex nut (A-1) and slide the driven disc in or out as required. Re-tighten connector hex nut to secure the driven disc in the proper position.

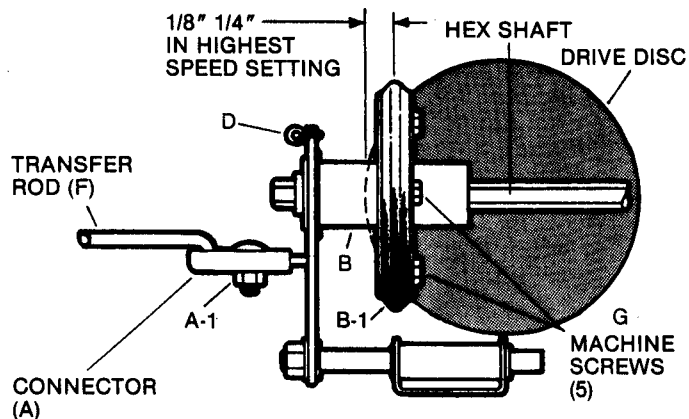

FIG. 13 -DRIVEN DISC COMPONENTS

DRIVEN DISC REPLACEMENT: If the driven disc rubber ring (B-1) is found to be badly chunked or worn down to within $1/16"$ of the metal rim of the driven disc hub (B), it must be replaced. Remove the clip (E) at the end of the transfer rod (F), and then turn the transfer rod (F) to a upright (vertical) position and detach from the connector (A) (FIG. 14 & 15). Unhook drive spring (D) (use needle nose pliers) and slide the driven disc assembly off hex-shaft.

Remove the five machine screws (G) and plate securing the driven disc rubber ring (B-1) to the hub (B) and replace the ring as shown in FIG. 15. Reverse procedures for re-assembly and installation.

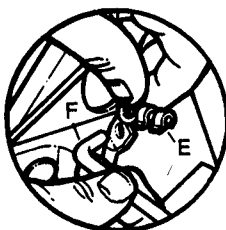
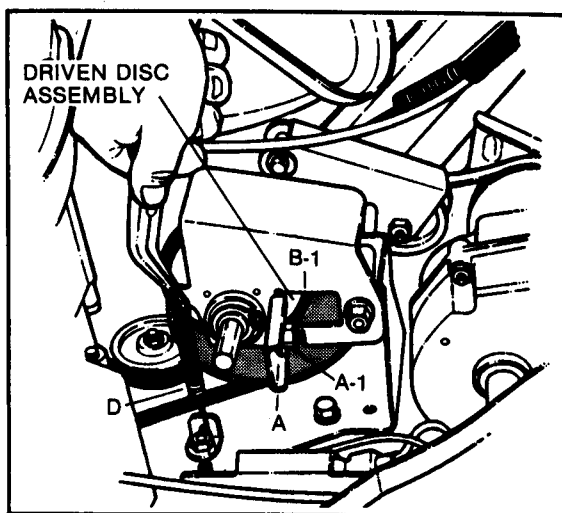
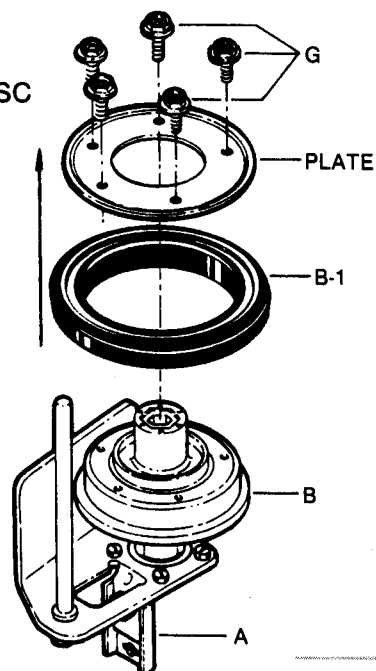

FIG. 14
DRIVEN DISC ASSEMBLY

FIG. 15 -DRIVEN DISC



BEARING REPLACEMENT: If the driven disc bearing fails, remove the complete driven disc assembly as previously described. Then remove the snap ring (H) (special pliers are required) and slide the driven disc assembly out of bearing.

Remove the four retaining screws (I) and then the bearing (J). Reassemble in reverse order. Refer to the illustration FIG. 16.

To replace the bearing on pulley end of hex-shaft, hold the shaft with an adjustable wrench (next to the pulley). Then remove the 3/8" retaining hex lock nut (located on outside of right rear wheel bracket). Carefully remove holder, O-ring, and bearing and replace the bearing. Reassemble and carefully reinstall the O-ring over the outside of new bearing - securely tighten the two retaining screws as shown in FIG. 16-A.

FIG. 16
BEARING REPLACEMENT

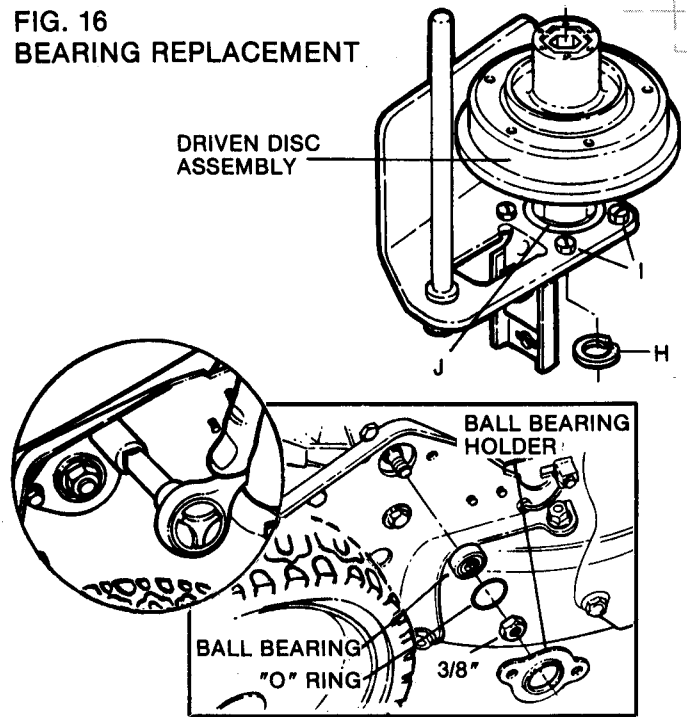

FIG. 16-A - BEARING REPLACEMENT

BELT SERVICE

Slippage (from worn belts) can prevent self-propelled models from maintaining optimum performance! On self-propelled models, the engine belt transmits power to the Poly-V-Belt, which in turn, engages the clutch to drive the transmission and rear drive wheels.

ENGINE BELT REPLACEMENT: Disconnect the spark plug wire and empty the fuel tank (or tape the vents in the filler cap closed to prevent fuel spillage).

Unhook the idler arm spring (A) from the right rear wheel bracket and remove the driven disc assembly as described in the DRIVEN DISC section. Tilt the mower up on its RIGHT wheels and remove the cutting blade and hub. Then remove the drive disc retaining nut (B) and internal tooth lockwasher (C). Lift the drive disc up from its position on the idler arm and remove worn belt. Loop one end of replacement belt over engine drive pulley and insert other end through deck opening. Loop the belt around driven pulley (on the lower portion of drive disc) and lower disc back into position on idler arm (with the idler AGAINST the engine belt - when idler arm spring (A) is reinstalled). Refer to FIG. 17.

Reinstall the internal tooth lock washer (C) and retaining nut (B) onto drive disc post (on underside of deck), and securely tighten. Test the pivoting action of the idler arm - it must pivot freely! Reinstall the blade and fasteners on shaft as explained in the BLADE SERVICE section. Use a stiff wire (such as a coat hanger) with a hook on end to pull the hooked end of idler arm spring (A) through the large hole in right wheel bracket, and then hook the spring's end through the smaller hole. If the Poly-V-Belt is NOT going to be replaced, reinstall the driven disc assembly.

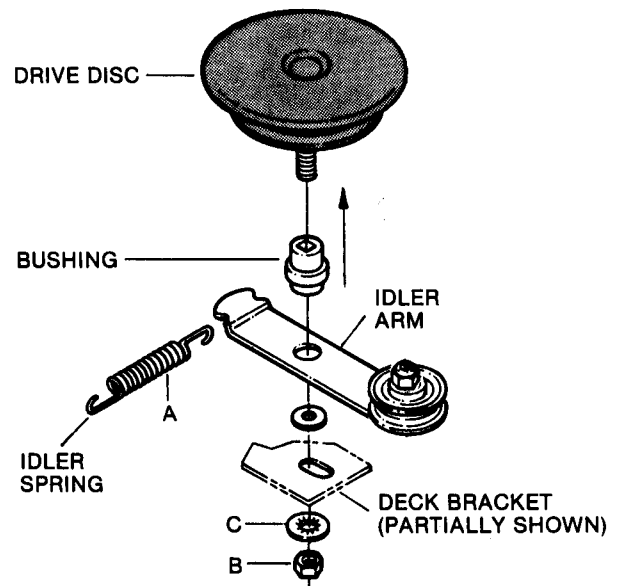
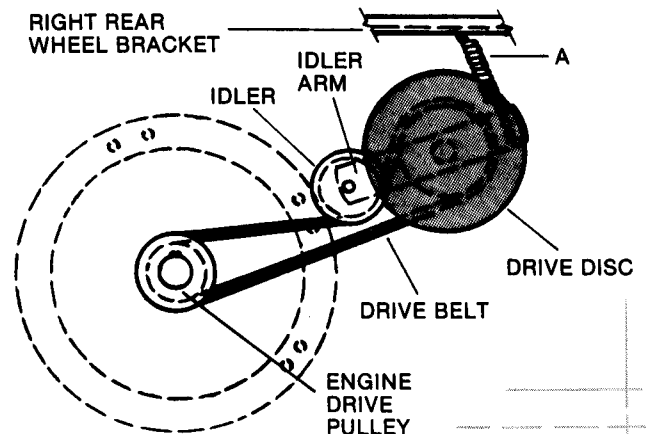

FIG. 17 - IDLER & ENGINE BELT DETAIL



POLY-V-BELT REPLACEMENT: The driven disc assembly must be removed first. Note the arrangement of the old belt around the three pulleys before cutting and removing it. Slip the replacement belt over the end of hex-shaft and onto pulley (A). Then work it onto idler pulley (B) and twist it sideways and pull upward between the differential bracket and transmission pulley (C) and then down into the pulley's groove. Make sure the belt is in each pulley's groove! Refer to FIG. 18.

NOTE: When properly installed, the lower span of Poly-V-Belt will be ABOVE the belt guide - below pulley (A).

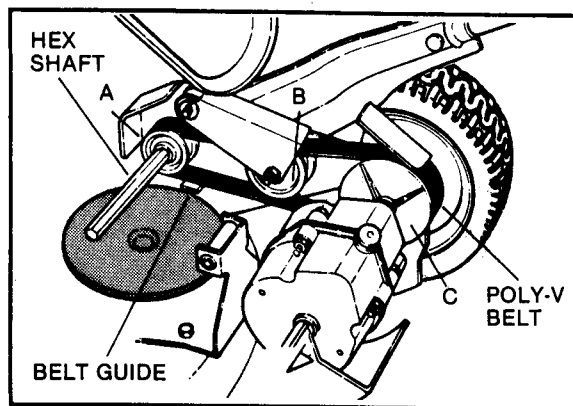

FIG. 18 -POLY-V BELT REPLACEMENT

STORAGE PROCEDURE

Refer to the engine manual for directions regarding engine storage preparations.

Prepare the mower for "end of season" storage as follows:

1. **DISCONNECT THE SPARK PLUG WIRE BEFORE ANY OTHER PREPARATIONS ARE MADE!**
2. Tape all openings closed to prevent spraying water into exhaust or air intakes during washing.
3. Turn the mower on its side and thoroughly clean the underside of the deck. Scrape away any accumulation of grass with a putty knife and/or wire brush. Then use a hose to wash down the underside of deck and allow to dry. Clean all external surfaces of mower and allow to dry.
4. Lubricate all exposed metal with a light coating of oil to prevent corrosion.
5. If so equipped, empty the grass bag to prevent decay of debris and formation of mold while in storage. The grass bag may be washed in detergent, but allow it to dry thoroughly!
6. Store the mower in a shed or other dry area, protected from weather.
7. Handles on push models may be tilted forward AFTER loosening both LOWER KNOBS 20. Grass bags and adaptors DO NOT need to be removed.

To tilt handles on self-propelled models, disconnect the transfer rod clip (on end of transfer rod and speed control lever) and follow the procedures above.

Carefully tilt the handles forward, "flexing" the control cables to prevent "kinks" (damage). Refer to FIG. 19.

HANDLE HEIGHT ADJUSTMENT

To raise or lower handle (14), loosen the adjusting locknuts (A) on both sides of handle shown in FIG. 20. Reset handle to desired position and re-tighten the locknuts.

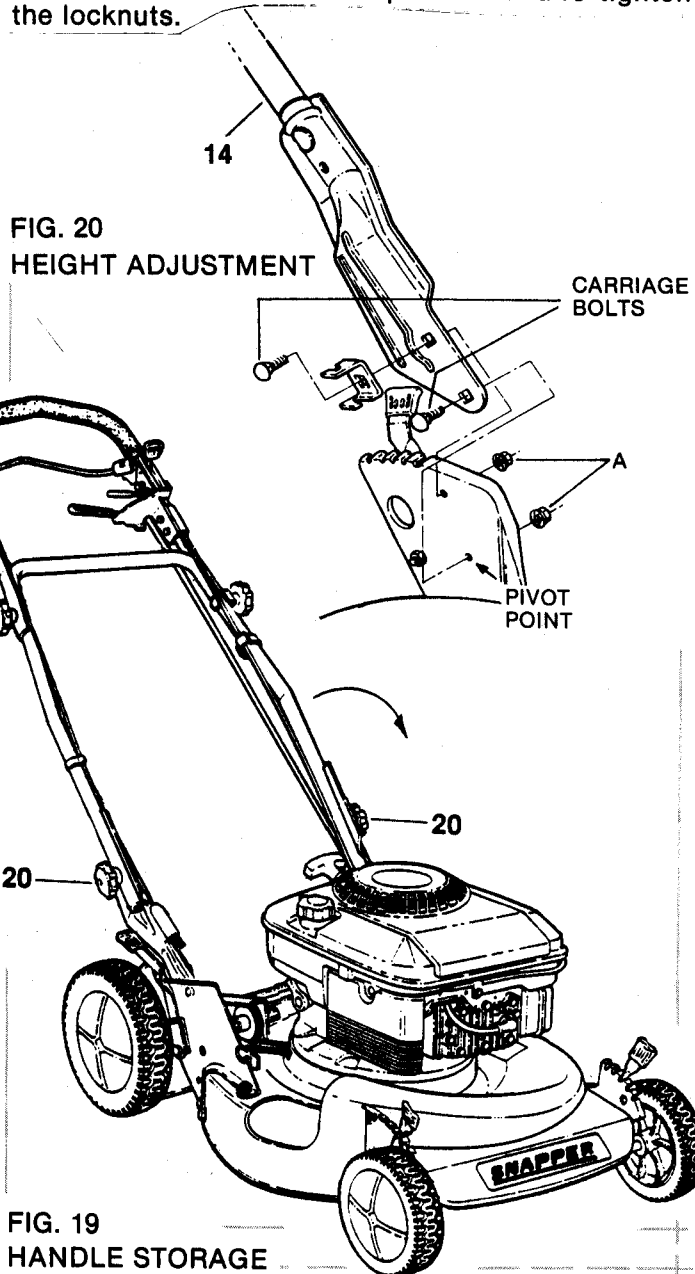

FIG. 19
HANDLE STORAGE

POPULAR ACCESSORIES

Your **SNAPPER** mower is very versatile and can, with the addition of the fine accessories described below, perform various lawn care duties. See your **SNAPPER** Dealer for additional information on these popular kits and the complete line of quality **SNAPPER** products!

GRASS BAG KIT: A side discharging mower can be easily converted for bagging operations whenever desired with this kit. Specify mower model when ordering.

RECYCLING KIT: This kit turns your unit into an effective recycling mower which cuts and chops grass into small nutritious mulch particles before blowing them directly into the lawn!

RECYCLING

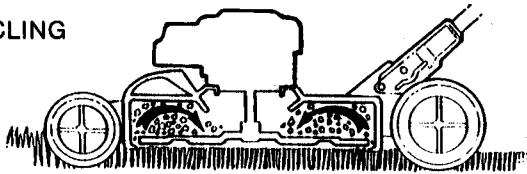

SIDE CHUTE KIT: **SNAPPER** mowers which are grass bag equipped, can be easily and quickly converted to side chute discharge units - to broadcast clippings. When it is once again desirable to bag grass clippings, they can be converted back to baggers in just a few minutes!

SNAPPERIZER KIT: This kit converts your mower into an outdoor vacuum "shredder". The mower will then broadcast "shredded" grass clippings and leaves out a side discharge chute or into a grass bag. Specify mower model when ordering.

SNAPPERIZER

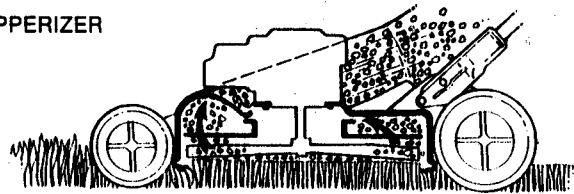

THATCHERIZER KIT: To prevent harmful "thatch" from occurring due to excessive accumulation of clippings, it is recommended that the lawn be dethatched periodically. The debris may then be vacuumed into a grass bag. The kit fits all 21" models.

THATCHERIZER

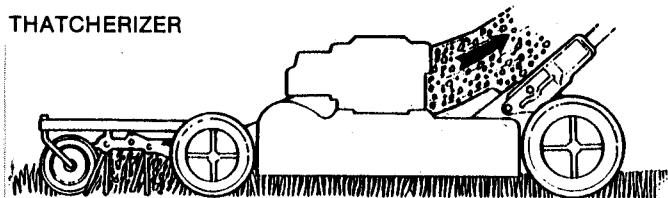

MANUFACTURER'S 2 YEAR LIMITED WARRANTY

For two (2) Years from purchase date for the original purchaser's residential, non-commercial use [ninety (90) days from purchase date for the original purchaser's commercial, rental, or other non-residential use], **SNAPPER POWER EQUIPMENT**, through any **SNAPPER** dealer will replace, free of charge, any part or parts found upon examination by the factory at McDonough, Georgia, to be defective in material or workmanship or both.

All transportation cost incurred by the purchaser in submitting material to a **SNAPPER** dealer for replacement under this warranty must be borne by the purchaser.

This warranty does not apply to engines and their components, as these items are warranted separately by their manufacturers, and does not apply to batteries which are covered separately. This warranty does not apply to parts that have been damaged by accident, alteration, abuse, improper lubrication, normal wear, or other cause beyond our control.

There is no other express warranty.

Implied warranties, including those of merchantability and fitness for a particular purpose, are limited to two (2) years from purchase date for the original purchaser's residential, non-commercial use [ninety (90) days from purchase for the original purchaser's commercial, rental or other non-residential use], and to the extent permitted by law any and all implied warranties are excluded. This is the exclusive remedy. Liabilities for consequential damages, under any and all warranties are excluded.

Some states do not allow limitations on how long an implied warranty lasts, or do not allow the exclusion or limitation of incidental or consequential damages, so the above limitation or exclusion may not apply to you.

This warranty gives you specific legal rights, and you may also have other rights which vary from state to state.

WARNING: THE USE OF REPLACEMENT PARTS OTHER THAN GENUINE SNAPPER PARTS MAY IMPAIR THE SAFETY OF SNAPPER PRODUCTS AND WILL VOID ANY LIABILITY AND WARRANTY BY SNAPPER ASSOCIATED WITH THE USE OF SUCH PARTS.

IMPORTANT: Please fill out the attached **SNAPPER** Product Registration Card immediately and mail to: **SNAPPER POWER EQUIPMENT, McDONOUGH, GEORGIA 30253**