

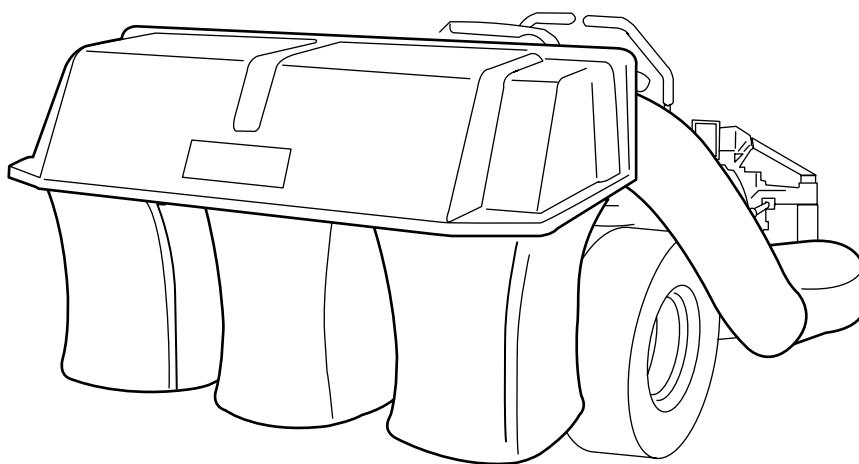

ATTACHMENT OPERATOR'S MANUAL



Clean Sweep Triple Catcher

Clean Sweep Triple Catcher

Mfg. No.	Description
1695065	Clean Sweep Triple Catcher

1732613

Rev. 00

Rev. Date 01/2006

TP 100-4268-00-AT-SMN

**THIS PAGE INTENTIONALLY BLANK
(FOR PLACEMENT ONLY - DO NOT PRINT)**

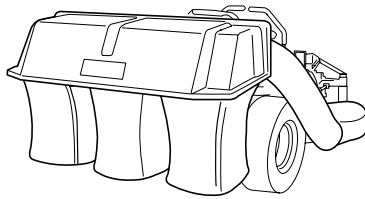

Table of Contents

Safety Rules & Information

General Warnings.....	2
Safety Decals	2

General Operating Information

Mowing with the Triple Catcher.....	3
Required Accessories.....	3
After Operation	3

Initial Turbo Installation -

Contents Turbo Installation Group	4
Install Turbo	5

Initial Counter Balance & Front Weight Carrier Installation -

Counter Balance Installation	10
Install Front Weight Carrier.....	10

Initial Hitch & Tube Installation -

Install Hitch Plate & Back Plate	11
Install Tubes & Deflector.....	12

Initial Collector Assembly

Assemble Catcher Bags	13
Install Cover.....	13

Removing & Re-attaching the Triple Catcher

Removing the Grass Catcher	14
Reattaching the Grass Catcher	15

NOTE: In these instructions, “left” and “right” are referred to as seen from the operating position.

Safety Rules & Information



Read these safety rules and follow them closely. Failure to obey these rules could result in loss of control of unit, severe personal injury or death to you, or bystanders, or damage to property or equipment. The triangle  in text signifies important cautions or warnings which must be followed.

GENERAL WARNINGS

- Know the unit's controls and how to stop quickly. **READ THE OPERATOR'S MANUALS.**
- Read and obey all safety decals.
- Only allow responsible adults, who are familiar with the instructions, to operate the unit.
- Disengage the PTO. Shut off the engine and wait for all moving parts to stop before attaching, adjusting, or disconnecting any part of the collection system.
- Check the collection system to make sure it is bolted tightly to the unit.
- DO NOT operate the unit without either the entire grass catcher or the deflector in place.
- Turn off the PTO to disengage the blades when not mowing.
- DO NOT mow in reverse. Always look down and behind before and while travelling in reverse.
- DO NOT turn sharply when travelling alongside a building or any object. Slow down before turning.
- DO NOT carry passengers.
- When collection system is removed from the mower deck, the deflector must be properly installed.
- Collector bags are subject to deterioration and wear during normal use. Inspect the bag periodically for tears, holes, or weak spots and replace with a new bag that meets manufacturer's durability standards.
- If the mower stalls or the collector chute plugs:
 1. Disengage the PTO;
 2. Stop the engine and remove the key;
 3. Set the parking brake, and wait for all moving parts to stop.
 4. Remove the foreign object or clear the chute with a piece of wood before restarting the engine. **NEVER place hands into COLLECTOR OR MOWER housing to clear jammed objects. Blower OR MOWER may rotate when object is removed.**
- For added stability and to prevent tipping or loss of control:
 - a. Use reduced speed on uneven ground and when turning corners.
 - b. Reduce loads on hillsides. It is recommended that the collection system be kept only half full when negotiating any slopes. Start mowing on slopes when the collection system is empty.
 - c. Mow up and down the face of slopes; never across the face of any slope.
- When operating on slopes, use front counterweights. **Never operate on slopes greater than 17.6% (10°).**

SAFETY DECALS

This unit has been designed and manufactured to provide you with the safety and reliability you would expect from an industry leader in outdoor power equipment manufacturing.

Although reading this manual and the safety instructions it contains will provide you with the necessary basic knowledge to operate this equipment safely and effectively, we have placed several safety labels on the unit to remind you of this important information while you are operating your unit.

All DANGER, WARNING, CAUTION and instructional messages on your rider, attachments and mower should be carefully read and obeyed. Personal bodily injury can result when these instructions are not followed. The information is for your safety and it is important! The safety decals below are on your product.

If any decals are lost or damaged, replace them at once. See your local dealer for replacements.

These labels are easily applied and will act as a constant visual reminder to you, and others who may use the equipment, to follow the safety instructions necessary for safe, effective operation.

ATTACHMENT DECALS

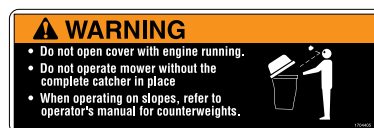

Decal - WARNING Do Not Open Cover
Part Number 1704405



Decal - WARNING
Part Number
1717291

Read and obey all operation and warning decals.



Operating Instructions



BEFORE OPERATION

Clear the lawn of all sticks, stones, wire and other debris which may be caught or thrown by the mower blades.

Check grass condition. If wet, wait until later in the day. If grass is wet, the grass catcher is likely to become plugged.

For efficient bagging, air circulation under the mower deck, through the chute and into the bag is very important.

For this reason, BEFORE YOU BEGIN MOWING you should make certain the underside of the mower and the underside of the catcher lid are free from grass and debris.

Make sure that there is a snug fit between mower deck, blower housing, tubes, and grass catcher cover.

MOWING WITH THE CATCHER

Always operate with throttle at full speed when mowing.

Grass should be cut often, and not too short. If grass is too long or lush it may be necessary to keep ground speed to a minimum or to cut only half the width of the mower to prevent clogging. If grass is long, operate with mower in high cutting position for first pass, cutting again in a lower position on a second pass.

Do not open the cover with mower engaged.

If a large amount of cut grass is spilling out from under deck, the tube may be plugged or the bags may be full—discontinue mowing, stop the unit, disengage the PTO, shut off the engine and then empty the catcher or clear the tube.

! WARNING

ALWAYS shut off the tractor. Disengage the PTO, and allow all moving parts to stop BEFORE disconnecting or clearing tube, or emptying catcher.

Before leaving the operator's position for any reason, engage the parking brake, disengage the PTO, stop the engine and remove the key.

To reduce fire hazard, keep the engine, rider and mower free of grass, leaves and excess grease. Do not stop or park rider over dry leaves, grass or combustible materials.

! CAUTION

Before you begin operating the unit be certain you have read all of the safety and operational information of this instruction sheet, as well as the Operator's Manual for the tractor and any other attachments.

REQUIRED ACCESSORIES

A front-mounted factory approved weight carrier and 66 lbs. worth of weights are required when using this rear-mounted grass catcher. **Never operate on slopes greater than 17.6% (10°).**

AFTER OPERATION

! CAUTION

Do not leave grass in bagger containers. Empty containers after each use and before storing. Failure to do so may result in spontaneous combustion which could develop into a fire.

Remove any debris from the the screen on the underside of the lid. *Note: The lid screen can be partially removed for easier cleaning and should be cleaned regularly.*

The blower housing and tube should be removed for cleaning.

Inspect the grass bags for wear or damage. Make sure that there is a snug fit between mower deck, blower housing, tubes, and grass catcher cover.

STORING THE GRASS CATCHER

Clean the grass catcher thoroughly using a mild detergent (other products may damage the tube). Remove any debris from the the screen on the underside of the lid.

If paint has been scratched on metal parts, touch up with paint, or apply a thin film of oil to prevent corrosion.

Store in a dry area. Dry thoroughly before storing for a long period of time. Always store away from moisture.

Initial Turbo Installation

Setup

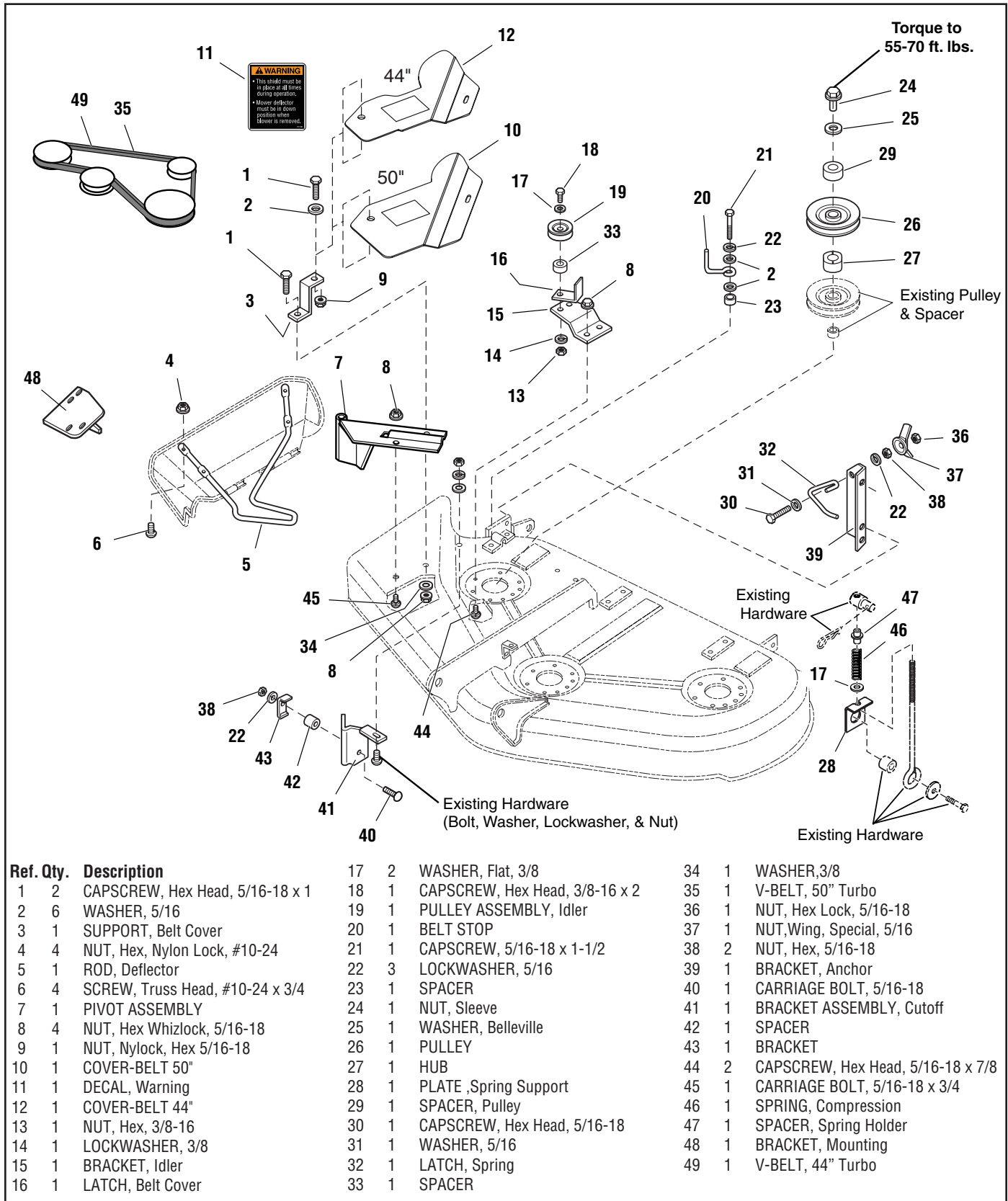

Figure 1. Contents of Turbo Installation Kit

TURBO INSTALLATION

Remove Mower Deck

Remove the mower deck from the unit (see Operator's Manual for instructions).

Deflector Removal

1. Remove and retain the carriage bolts, washers, lockwashers, and nuts (A, Figure 3) holding the deflector rod to the deck. Remove and discard the deflector rod. Retain the deflector.

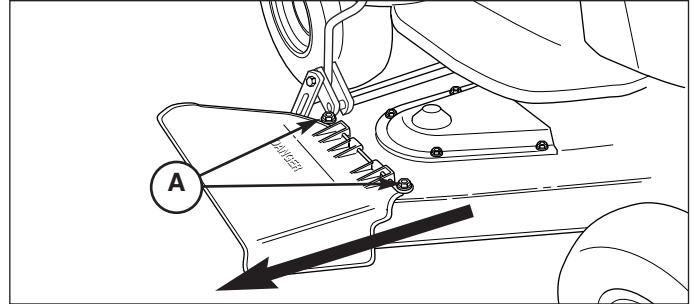

Figure 3. Remove Deflector
A. Carriage Bolts, Washers, Lockwashers, & Nuts

Install Discharge Baffle

1. Attach the baffle bracket (A, Figure 4) under the mower housing as shown, and insert the carriage bolt (from step 1) through the bracket & deck hole at (B).
2. Attach the "L" bracket (C) to the baffle (A), and over the stone guard (D). Attach with carriage bolt, spacer, lockwasher and nut as shown.

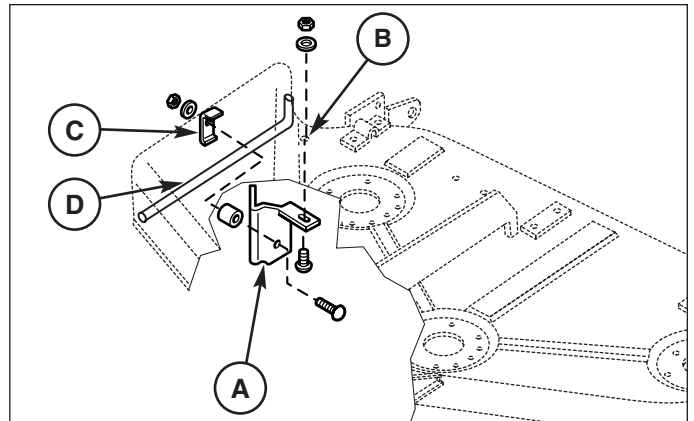

Figure 4. Install Discharge Baffle
A. Baffle Bracket C. L-Bracket
B. Mounting Hole D. Stone Guard

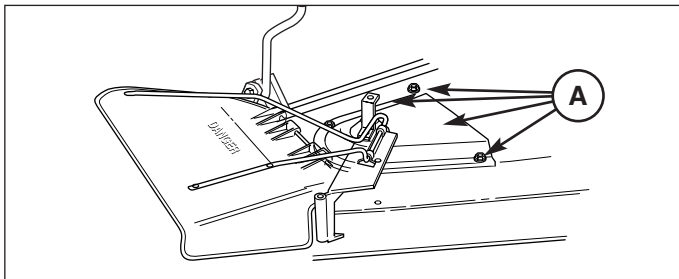

Figure 2. Install Discharge Baffle
A. Cover and Bolts

Install Deflector Hinge Assembly

1. Remove the bolts (A, Figure 2) securing the RH arbor cover, then remove the cover from the deck. Discard the cover and bolts (A).
2. Remove and discard the plastic plugs from the deck at the locations used by bolts (F & B, Figure 5).
3. Slide the deflector rod (D) through the pivot bracket (E).
4. Secure the front of the pivot bracket with a 5/16-18 x 3/4" carriage bolt (F) and flange whizlock nut (C).
5. Secure the back of the pivot bracket (E) and belt cover support (A) with a 5/16-18 x 1 capscrow (B), 5/16 washer (G), and flange whizlock nut (C).

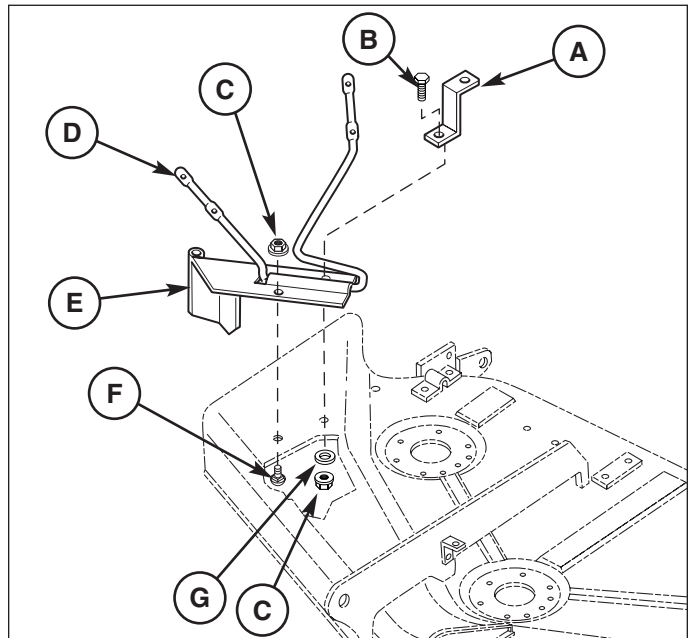

Figure 5. Install Deflector Hinge
A. Belt Cover Support F. 5/16-18 x 3/4
B. 5/16-18 x 1 Capscrow Carriage Bolt
C. 5/16-18 Whizlock Nuts G. 5/16 Washer
D. Deflector Support Rod
E. Pivot Bracket

Initial Turbo Installation

Install Deflector

1. See Figure 6. Drill four 13/64" holes from the bottom of the deflector at the pre-molded drill points (A, bottom of deflector).
2. Attach the deflector to the support rod wire-form using four #10-14 x 3/4 truss head screws and nylock nuts.

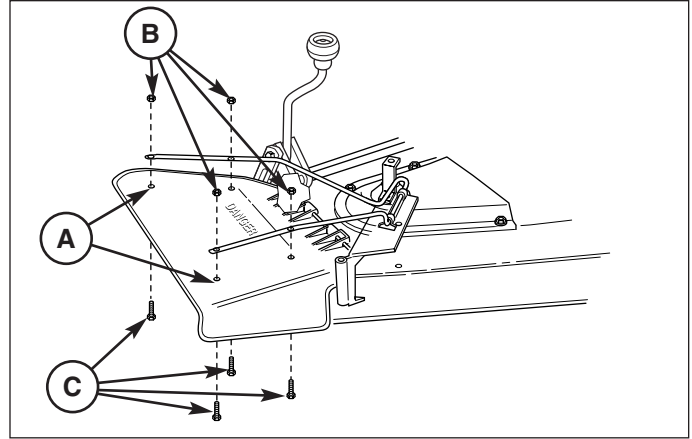

Figure 6. Install Deflector

- A. 13/64 Hole Locations C. Screws, #10-24 x 3/4
B. Nylock Nuts

Install Belt Guide

1. See Figure 7 & 8. Locate the taptite screw that will be replaced by capscrew (C). Remove and discard the taptite screw
2. Assemble the 5/16-18 x 1-1/2 capscrew (C), lock-washer (E), washers (B), belt stop (D) and spacer (A).
3. Secure the belt stop assembly to the deck in the location shown.

Note The belt stop (D, Figures 7 & 8) is located and oriented differently in 44" and 50" applications. For all applications, when turbo is installed, belt stop (D) should be outside the belt 1/8" away from the backside of the belt.

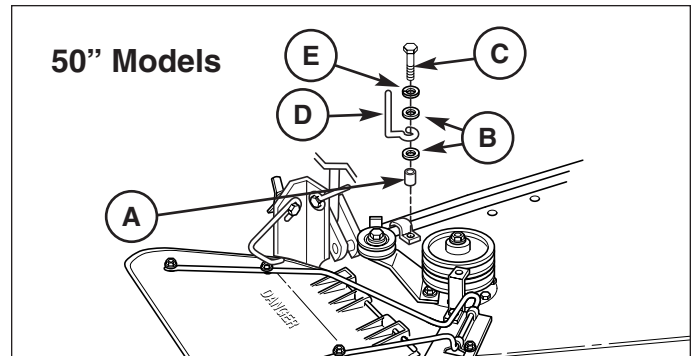

Figure 7. Install Belt Guide

- A. Spacer D. Belt Stop
B. 5/16 Washers E. Lockwasher, 5/16
C. Capscrew, 5/16-18 x 1-1/2

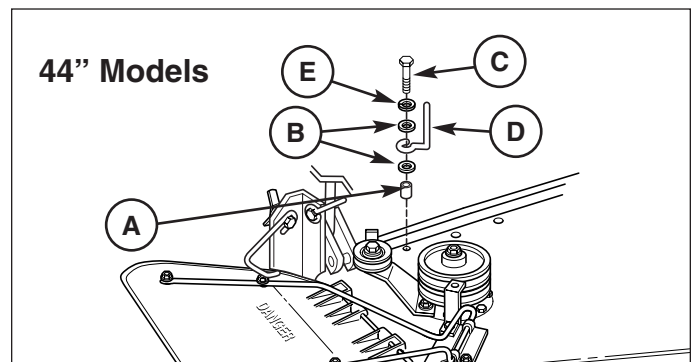

Figure 8. Install Belt Guide

- A. Spacer D. Belt Stop
B. 5/16 Washers E. Lockwasher, 5/16
C. Capscrew, 5/16-18 x 1-1/2

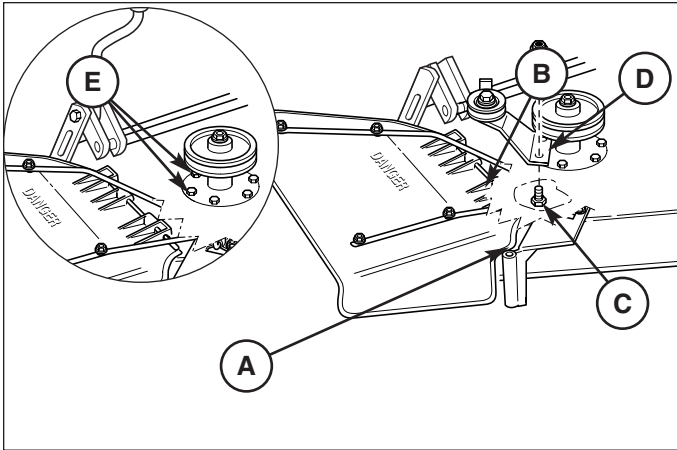

Figure 9. Install Idler Assembly

- | | |
|-----------------------------------|-----------------------------|
| A. Idler Assembly. | D. Locknuts, 5/16-18 |
| B. Belt Guide | E. Taptite Screws |
| C. Capscrew, 5/16-18 x 7/8 | |

Install Idler Assembly & Belt Guide

1. See Figure 9. Remove and discard the two taptite screws from locations (E).
2. Insert two 5/16-18 x 7/8 capscrews (C) through the mower deck and arbor. Tighten the capscrews.
3. Mount the idler pulley assembly (A) to the deck using the two 5/16-18x 7/8 capscrews (C) and 5/16-18 whizlock nuts (D).

Install Turbo Drive Pulley

1. See Figure 10. Remove the arbor drive belt from the right side arbor pulley.
2. Remove and discard the flange nut and spring washers securing the arbor pulley and spacer (A). Retain the pulley and spacer (A).
3. Install the new spacers (B & F), turbo drive pulley (C), spring washer (D), and sleeve nut (E). Be sure the notches in the pulleys and spacers are aligned. Install the spring washer concave side down. Torque the sleeve nut to 55-70 ft. lbs. (74-95 N.m).
4. Reinstall the arbor drive belt on the lower pulley.

Install Anchor Bracket

1. See Figure 12. If not already done, assemble the anchor bracket and related components as shown in Figure 11.
2. Attach the anchor bracket assembly (B, Figure 12) to the mower deck using 5/16-18 x 1 capscrews (A) and 5/16-18 locknuts (C).

NOTE: The deflector latch **MUST** secure the deflector in a down position—as shown in Figure 7.

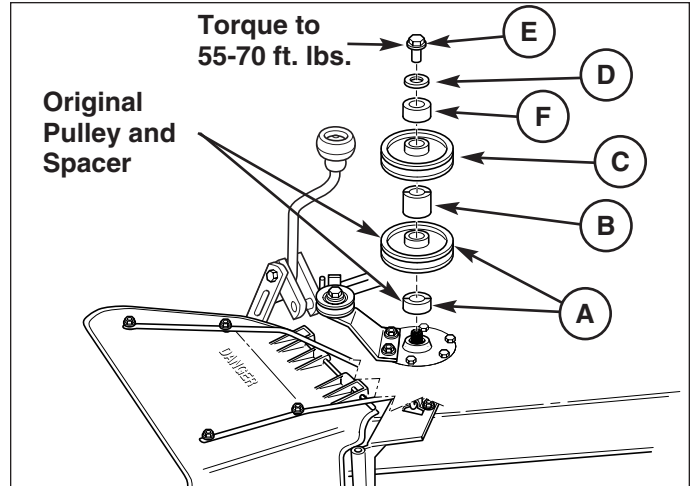

Figure 10. Install Turbo Drive Pulley

- | | |
|--|-------------------------|
| A. Original Pulley & Spacer | D. Spring Washer |
| B. Spacer, W/Notches (New) | E. Sleeve Nut |
| C. Pulley (New) | F. Spacer (New) |

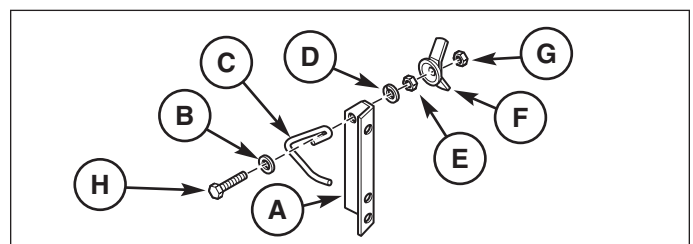

Figure 11. Anchor Bracket Assembly

- | | |
|-----------------------------------|-------------------------------------|
| A. Anchor Bracket | E. Nut, Hex, 5/16 |
| B. Lockwasher, 5/16, Large | F. Wing Nut, 5/16 |
| C. Latch, Spring | G. Locknut, 5/16 |
| D. Lockwasher, 5/16, Small | H. Capscrew, 5/16-18 x 2-1/2 |

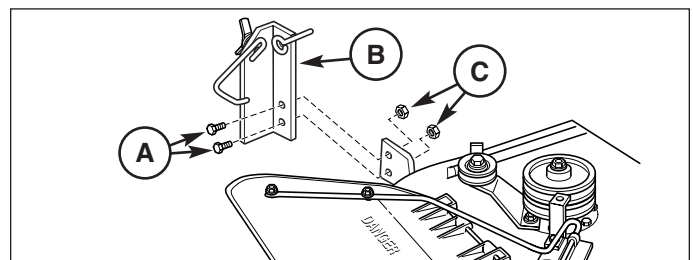

Figure 12. Anchor Bracket Installation

- | | |
|----------------------------------|--------------------------|
| A. Capscrews, 5/16-18 x 1 | B. Anchor Bracket |
| C. Locknut, 5/16-18 | |

Initial Turbo Installation

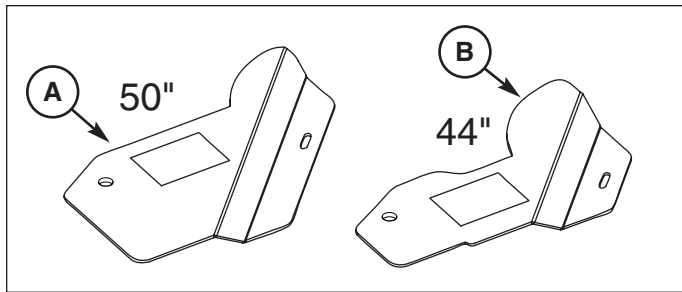

Figure 13. Belt Cover Plates

- A. Belt Cover Plate for 50" Mower
- B. Belt Cover Plate for 44" Mower

WARNING

When the turbo blower assembly is removed from the mower deck, the deflector **MUST** be properly installed.

Install Belt Cover Plate

1. Attach the belt cover plate (B, Figure 14) to the support bracket (E) using a 5/16-18 x 1 capscrew (C), washer (D) and nylock nut (F).

NOTE: This cover plate must be able to pivot on the support bracket. Different belt covers are required for different applications. Refer to Figure 13.

2. Rotate the belt cover until the notch catches the idler assembly belt cover latch (A, Figure 14). Cover latch (A) may need to be rotated for proper alignment.

Install Turbo Belt

1. Locate the correct drive belt for your installation: 44" models require drive belt 1705142, 50" models require drive belt 1707956 (the part number is stamped on the belt).
2. Loosen the hardware securing the drive pulley belt guide (B, Figure 15 & 16) and the idler pulley (C)
3. Install the drive belt as shown in Figures 15 & 16.
4. Tighten the hardware securing the drive pulley belt guide (B) and idler pulley (C). The idler belt guide should be within 1/16" of the belt.

Install Mounting Bracket

1. See Figures 15 & 16. Locate and remove the two longer capscrews used to secure the rear of the turbo housing and idler spring anchor.
2. Install the turbo mounting bracket (A) using the removed hardware. Note that the bracket is mounted in two different positions depending on the application.

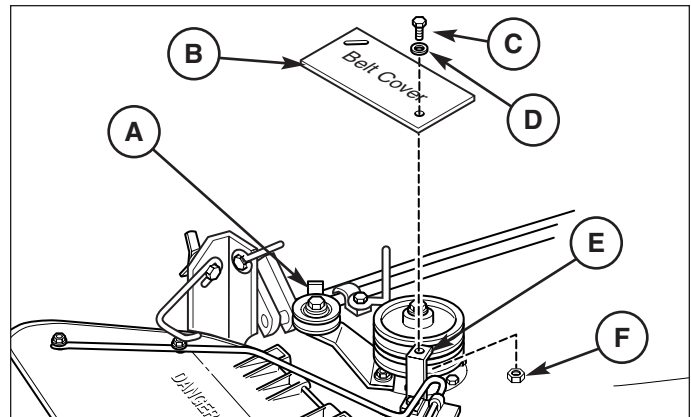

Figure 14. Install Belt Cover Plate

- A. Belt Cover Latch
- B. Belt Cover Plate
- C. Capscrew, 5/16-18 x 1
- D. Washer, 5/16
- E. Support Bracket
- F. Nylock Nut, 5/16

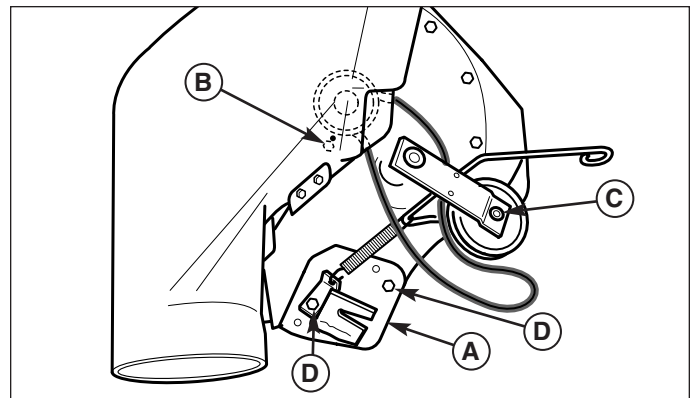

Figure 15. Belt Routing - 44" Models

- A. Mounting Bracket
- B. Drive Pulley Belt Guide Hardware
- C. Idler Pulley Hardware
- D. Mounting Bracket Hardware

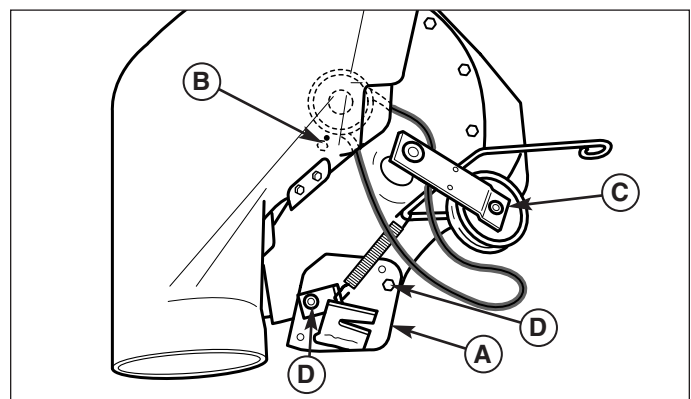

Figure 16. Belt Routing - 50" Models

- A. Mounting Bracket
- B. Drive Pulley Belt Guide Hardware
- C. Idler Pulley Hardware
- D. Mounting Bracket Hardware

Initial Turbo Installation

Install Turbo Blower

1. Install the turbo unit by sliding the turbo pivot rod into the pivot bracket at the front edge of the mower deck (A, Figure 17).
2. Tilt the deflector (B) UP.
3. Rotate the turbo unit (C) into position on the discharge of the mower deck, and “latch” the slot in the turbo housing over and onto the anchor bracket at (D). Tighten the wing nut (E) to secure.

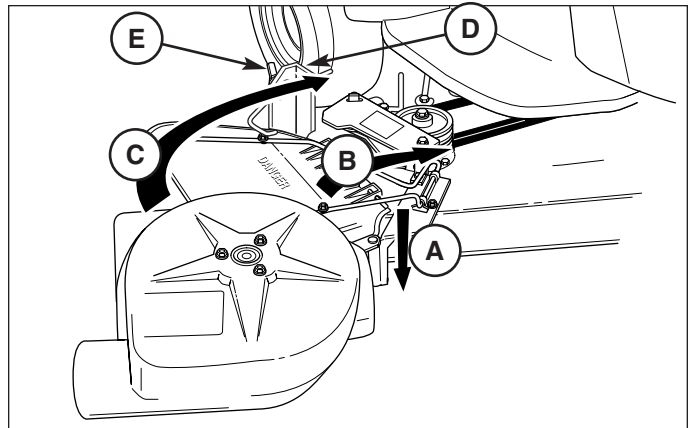

Figure 17. Install Turbo Blower

A. Pivot Bracket
B. Deflector
C. Turbo

D. Anchor Bracket
E. Wing Nut

Install Turbo Drive Belt

1. See Figure 18. Attach the turbo belt to the top RH pulley on the mower deck. Pull back on the belt tensioning lever to slacken the belt. A view (from right front of mower) of the belt routing is shown at right.

NOTE: While attaching, it may be necessary to unlatch the turbo and realign the belt on the pulleys inside the turbo housing.

2. After the belt is installed, adjust the belt stop (D, Figure 7 & 8) so that it is 1/8” away from the backside of the belt.

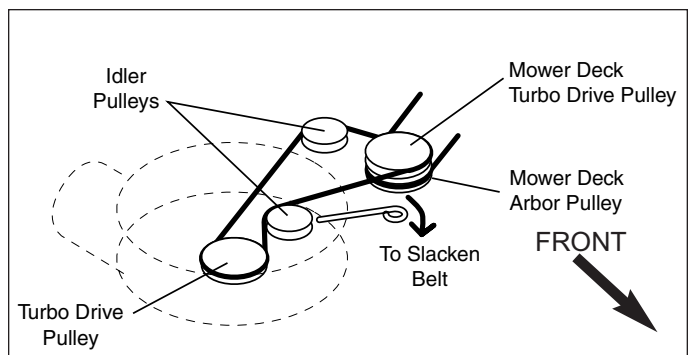

Figure 18. Turbo Belt Routing

Secure Belt Cover

1. The belt cover plate (A, Figure 19) is a safety shield — after attaching or detaching the turbo unit, it MUST BE rotated onto the belt cover latch (B).

CAUTION

Before you begin operating the unit with the Turbo attached, be certain you have read all of the safety and operational information on the last page of this instruction sheet, as well as the Operator’s Manual for the tractor and any grass catchers or other collection devices used in conjunction with this turbo blower.

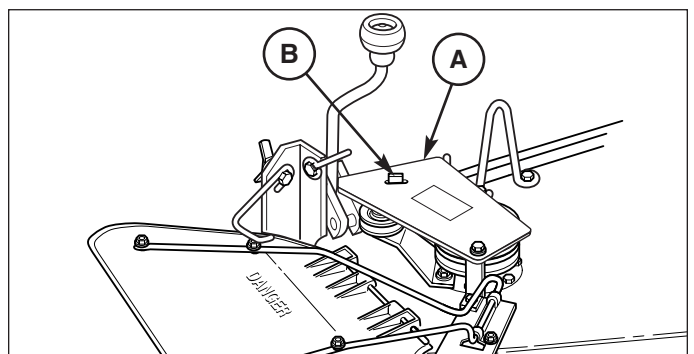
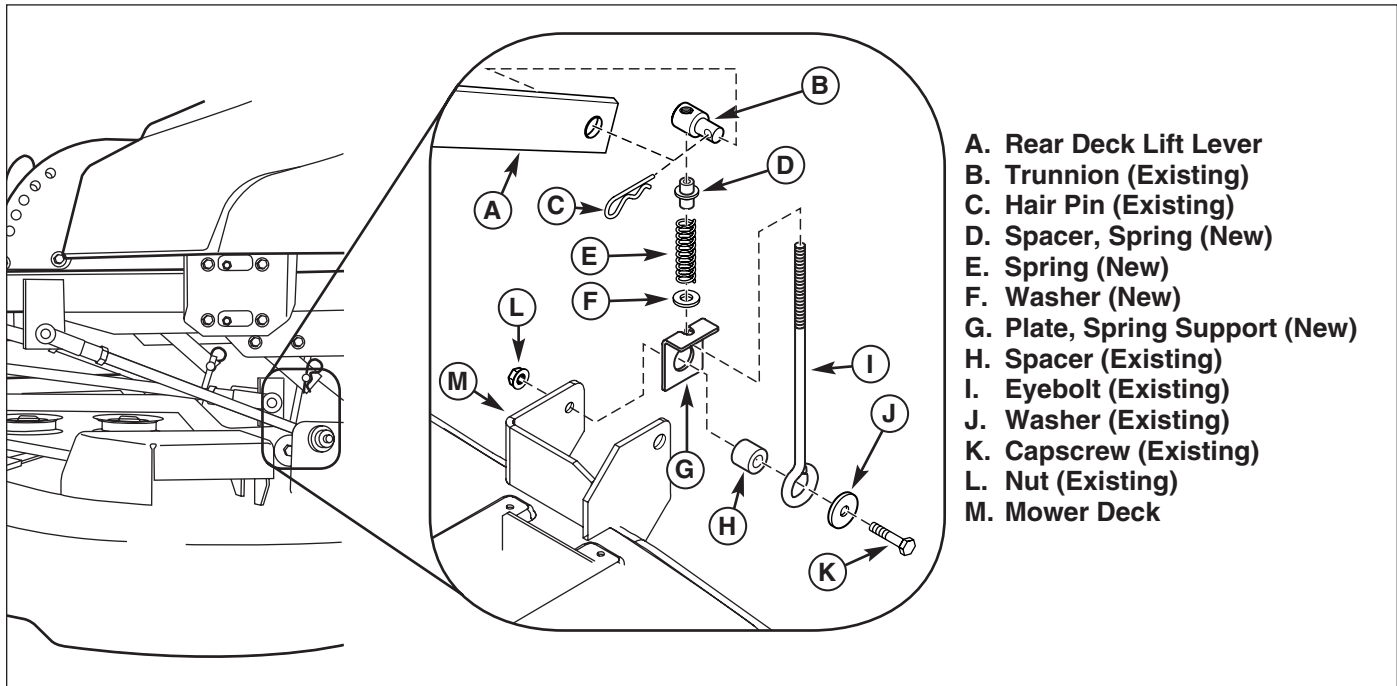
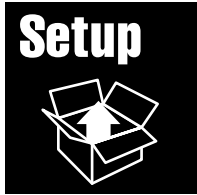

Figure 19. Belt Cover

A. Belt Cover Plate
B. Belt Cover Latch

Initial Counter Balance & Weight Carrier Installation



- A. Rear Deck Lift Lever
- B. Trunnion (Existing)
- C. Hair Pin (Existing)
- D. Spacer, Spring (New)
- E. Spring (New)
- F. Washer (New)
- G. Plate, Spring Support (New)
- H. Spacer (Existing)
- I. Eyebolt (Existing)
- J. Washer (Existing)
- K. Capscrew (Existing)
- L. Nut (Existing)
- M. Mower Deck

Figure 1. Counter Balance Installation

COUNTER BALANCE & WEIGHT CARRIER INSTALLATION

Counter Balance Installation

1. Remove hair pin (C, Figure 1) from trunnion (B). Remove trunnion (B) from rear deck lift lever (A). Mark or measure trunnion position on rear deck lift lever. Remove trunnion (B) from eyebolt (I).
2. Remove capscrew (K), washer (J), eyebolt (I), spacer (H) and nut (L) from mower deck (M).
3. Thread eyebolt (I) through plate (G) as shown.
4. Attach capscrew (K), washer (J), eyebolt (I), spacer (H), to mower deck (M) securing with nut (L).
5. Slide washer (F), spring (E), and spacer (D) onto eyebolt (I) as shown.
6. Install trunnion (B) onto eyebolt (I) to position of measurement or mark from step 1.
7. Install trunnion (B) into rear deck lift lever (A) secure with hair pin (C). Check deck leveling as described in Operators Manual and make necessary adjustments.

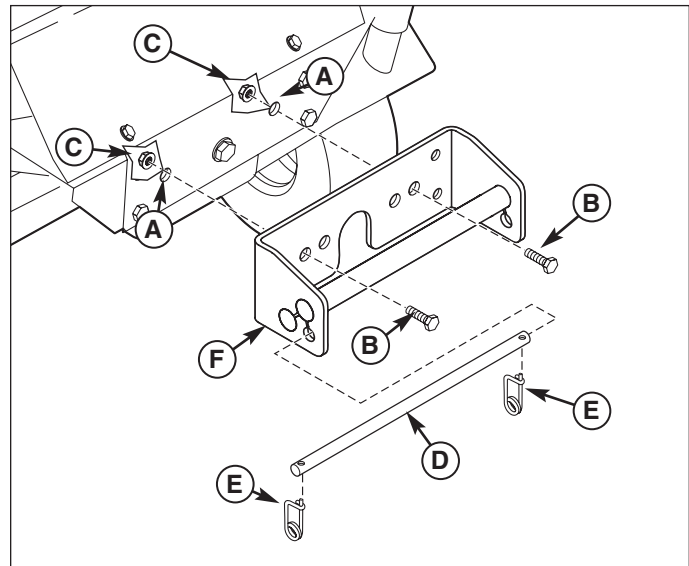
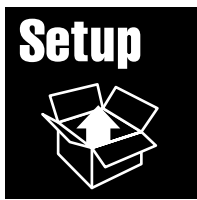

Figure 2. Front Weight Carrier Installation

- A. Holes
- B. Capscrews, 1/2-13 x 1-1/4
- C. Locknut, 1/2-13
- D. Rod
- E. Clips, Safety
- F. Carrier, Weight

Front Weight Carrier Installation

1. Install carrier (F) as shown securing with 1/2-13 x 1-1/4 capscrews (B), and 1/2-13 locknuts (C).
2. Rod (D) and safety clip (E) are used to secure required weights.



Initial Hitch & Tube Installation

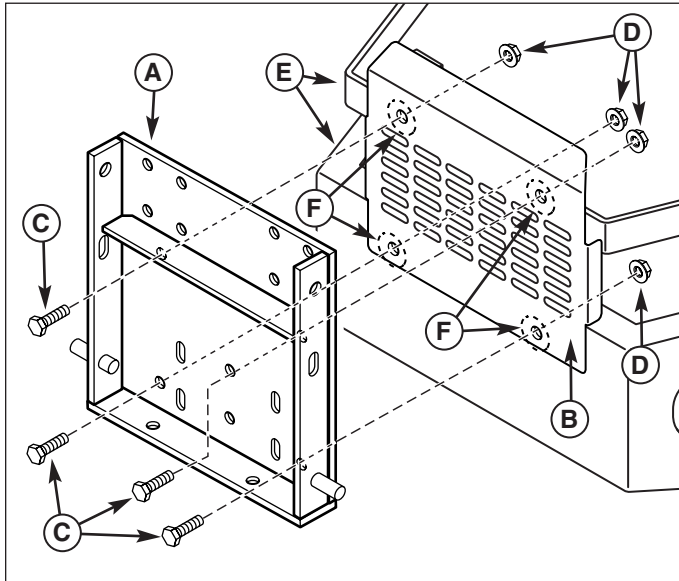

Figure 1. Install Hitch Plate (Flat Style Bumper)
A. Hitch Plate **D. Locknuts, 1/2-13**
B. Heat Shield **E. Upper & Lower**
C. Capscrews Hex, **Bumper**
1/2-13 x 1-1/4 **F. existing Holes**

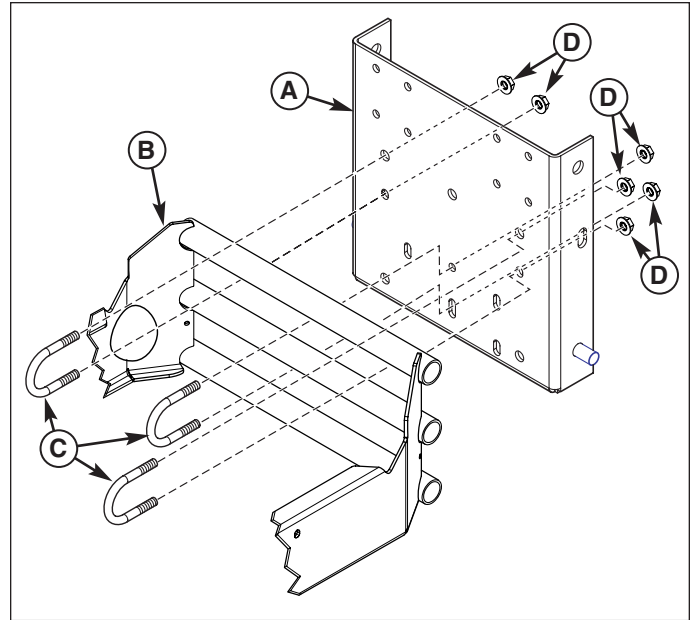

Figure 2. Install Hitch Plate (Tube Style Bumper)
A. Hitch Plate **C. U-Bolts**
B. Bumper, Tube **D. Locknuts, 3/8-16**

HITCH & TUBE INSTALLATION

Install Hitch Plate and Back Plate

Flat Style Bumper

1. Remove and discard hardware holding heat shield (B, Figure 1) to upper and lower bumper (E).
2. Open existing holes (F) in heat shield (B) and upper & lower bumper (E) to 17/32". Install hitch plate (A) to upper and lower bumper (E) keeping heat shield (B) in between as shown. Secure with 1/2-13 x 1-1/4 cap screws (C) and 1/2-13 locknuts.

Tube Style Bumper

1. Center the and secure hitch plate (A, Figure 2) to the bumper (B) with u-bolts (C) and 3/8-16 locknuts (D) as shown.

All Style Bumpers

1. Install the cover plate (F, Figure 3) on the back plate (A). Secure with four 5/16-18 x 3/4 cap screws (I), washers (E) and 5/16-18 locknuts (H).
2. Attach the back plate (A) to the support assembly (B) using 5/16-18 x 1 carriage bolts (G), 5/16 lockwashers (C) and 5/16 nuts (D).
3. Set the back plate and support (A, Figure 4) onto pins of hitch plate (C). Secure with rod (D) and hair pin (B).

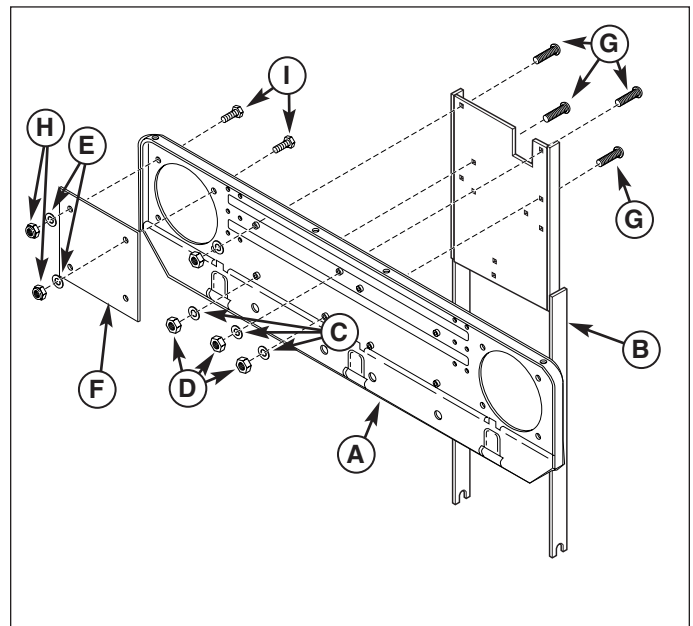

Figure 3. Install Hitch Assembly
A. Back Plate **G. Carriage Bolts,**
B. Support Assembly **5/16-18 x 1**
C. Lockwashers, 5/16 **H. Nylock Nut, 5/16-18**
D. Nut, 5/16-18 **I. Capscrews,**
E. Washers, 5/16 **5/16-18 x 3/4**
F. Cover Plate

Initial Hitch & Tube Installation

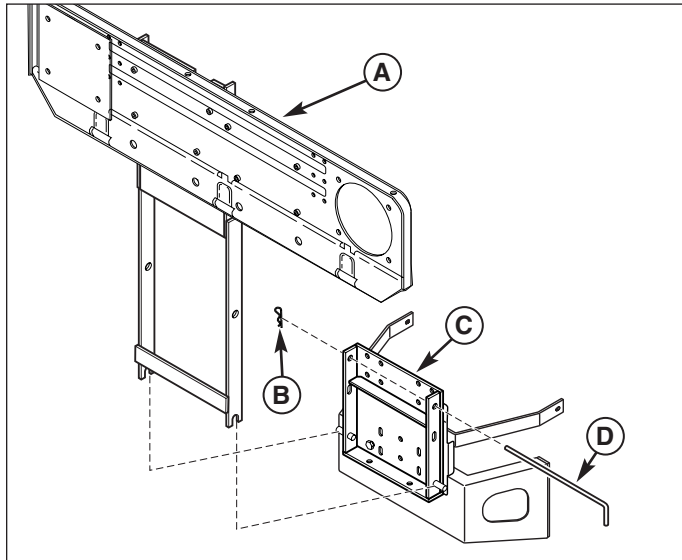

Figure 4. Install Back Plate (Flat Style Bumper shown)
A. Back Plate and Support **C. Hitch Plate**
B. Hair Pin **D. Rod**

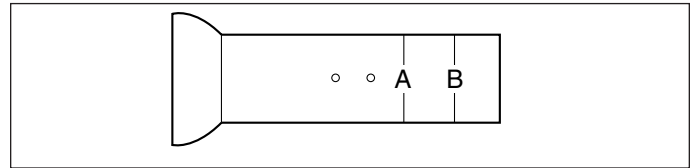

Figure 6. Upper Tube Length

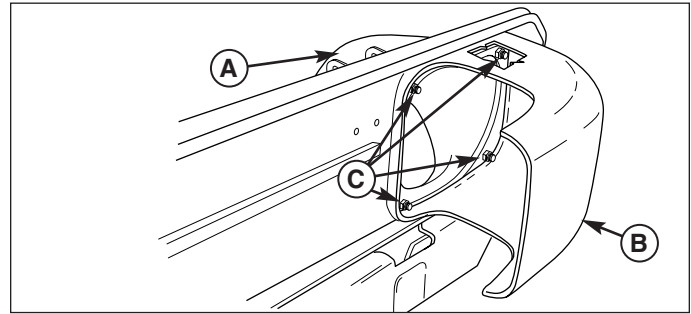

Figure 7. Mount Deflector and Tube Pivot
A. Tube Pivot **C. 5/16" Mounting Hardware**
B. Deflector

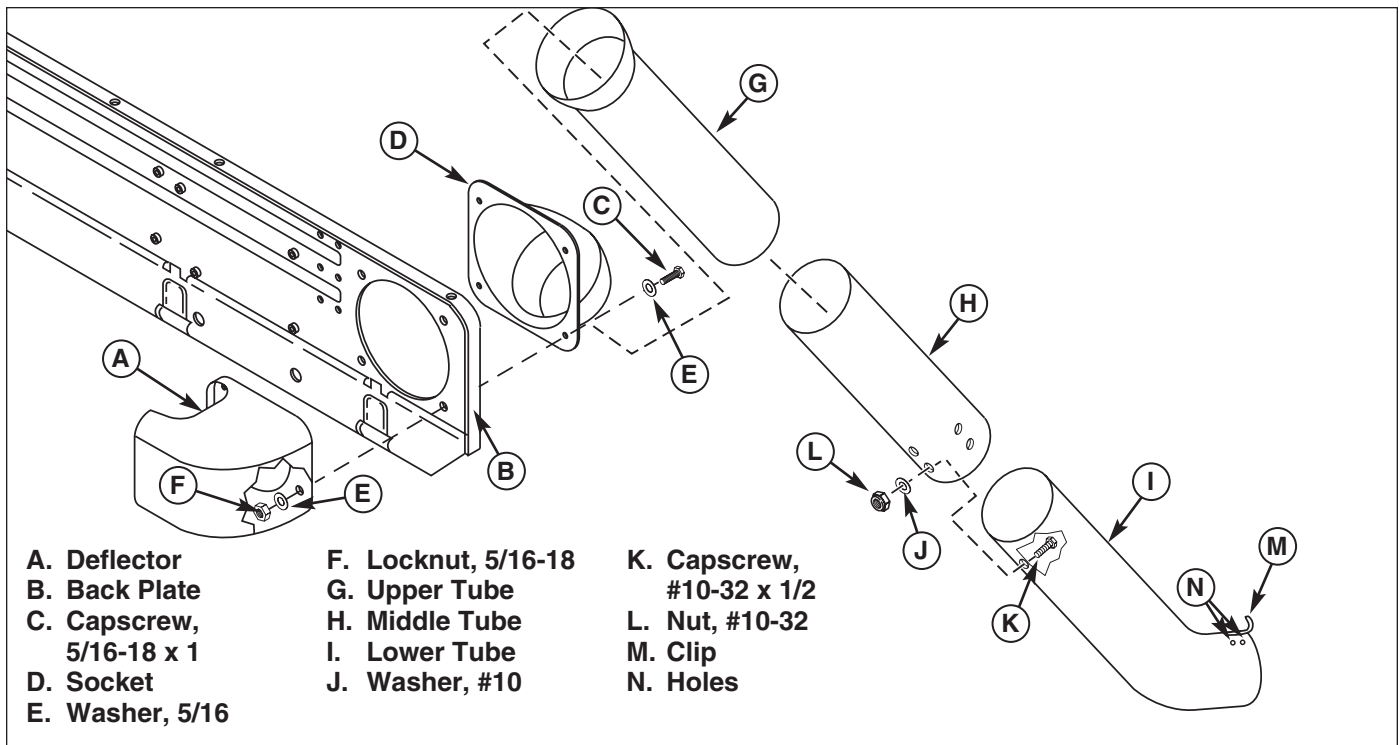

Figure 5. Assemble Tubes & Deflector

Install Tubes & Deflector

1. Some 50" models covered by this manual require upper tube (G, Figure 6) to be shortened. Shorten tube by cutting through along line "B" line. See Figure 5.
2. If not already done, insert the upper tube (G, Figure 5) into the socket (D). Insert the tube from the front. This will require some effort.
3. Mount the socket (D) and deflector (A) to the back plate (B) using the four 5/16-18 x 1 cap screws (C),

eight flat washers (E), and four nylock nuts (F) as shown in Figures 5 & 7.

4. Insert the lower tube (I, Figure 5) into the middle tube (H). Secure the tubes as shown in Figure 5 using #10-32 x 1/2 cap screws (K), washer (J) and #10-32 nut. Insert middle tube (H) (Secure the elbow to the turbo using clip (M). Clip (M) may need to be relocated to a different set of holes (N) to ensure secure fit.

Note: Use correct hole locations to maintain proper tube connections and prevent lower tube from disconnecting from the turbo.

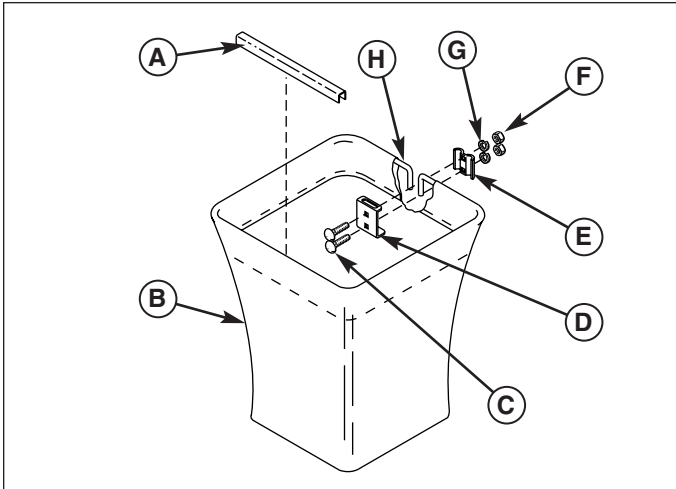

Figure 1. Assemble Catcher Bags

- | | |
|--------------------------------|---------------|
| A. Clip | E. Clamp |
| B. Cloth Bag | F. Nut |
| C. 5/16-18 x 3/4 Carriage Bolt | G. Lockwasher |
| D. Hanger Bracket | H. Wire Hoop |

COLLECTOR ASSEMBLY

Assemble Catcher Bags

1. See Figure 1. Insert the wire hoop (H) through the cloth bag (B).
2. Install the clamp (E) and hanger bracket (D). Secure with two 5/16-18 x 3/4 carriage bolts (C), lockwashers (G) and nuts (F).

Install Cover

1. See Figure 2. Hook the bags (A) on the back plate (B). *Note: If desired, the bags can be lined with 30 gallon trash bags for easy disposal.*
2. See Figure 3. Set the cover (A) on top of the bags (B) and align the hinges (C).
3. See Figure 4. Install the hinge pins (B) through the hinges (C) and secure with a hair pin clip (D).

NOTE: Push the hair pin clips all the way on or they will be bent by the hinge when the cover is opened.

CAUTION

Before you begin operating the unit be certain you have read all of the safety and operational information of this instruction sheet, as well as the Operator's Manual for the tractor and any other attachments.

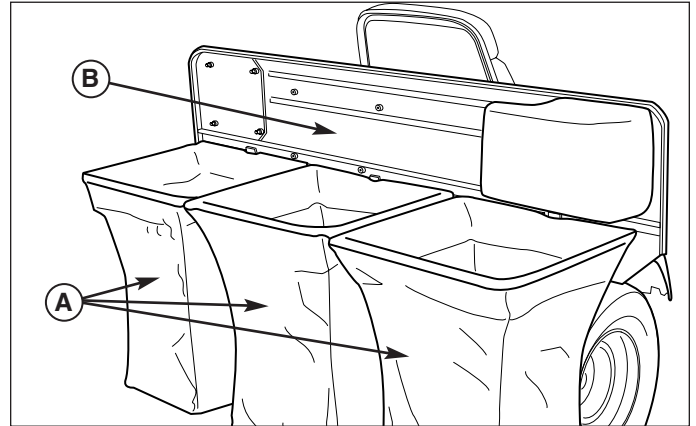

Figure 2. Install the Bags

- A. Bags
- B. Back Plate

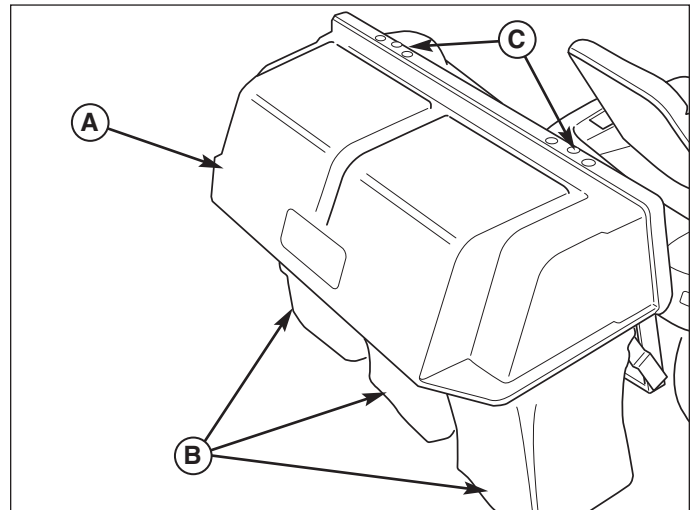

Figure 3. Install Cover

- A. Cover
- B. Bags
- C. Hinges

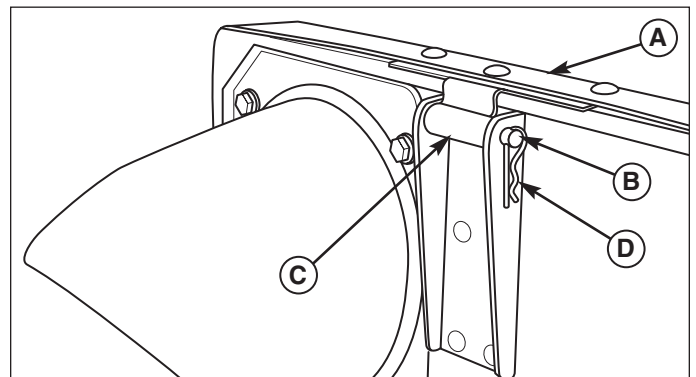

Figure 4. Install Hinge Pins

- A. Cover
- B. Hinge Pin
- C. Hinge
- D. Hair Pin Clip

Removing & Re-attaching Grass Catcher

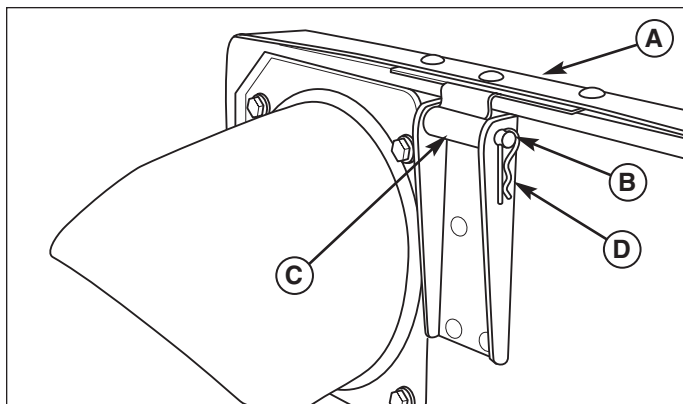

Figure 1. Remove the Cover

- A. Cover
- B. Hinge Pin
- C. Hinge
- D. Hair Pin Clip

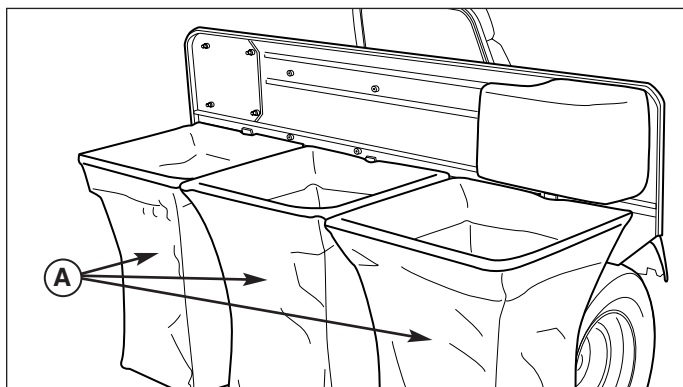

Figure 2. Remove the Bags

- A. Bags

REMOVING & RE-ATTACHING THE GRASS CATCHER

Removing the Grass Catcher & Tubes

1. Remove the hair pin clips (D, Figure 1) and hinge pins (B) and remove the cover (A).
2. Remove the bags (A, Figure 2) by lifting them off their hooks. Empty any grass out the bags.
3. Unclip middle and lower tube assembly (B, Figure 4) and remove from turbo and upper tube.
4. **Warning: Back plate (A) will fall when rod (D) is removed.** Remove the hair pin (B, Figure 3) and rod (D) while holding back plate (A).
5. Lift the back plate and support assembly (A, Figure 3) off hitch plate (C).

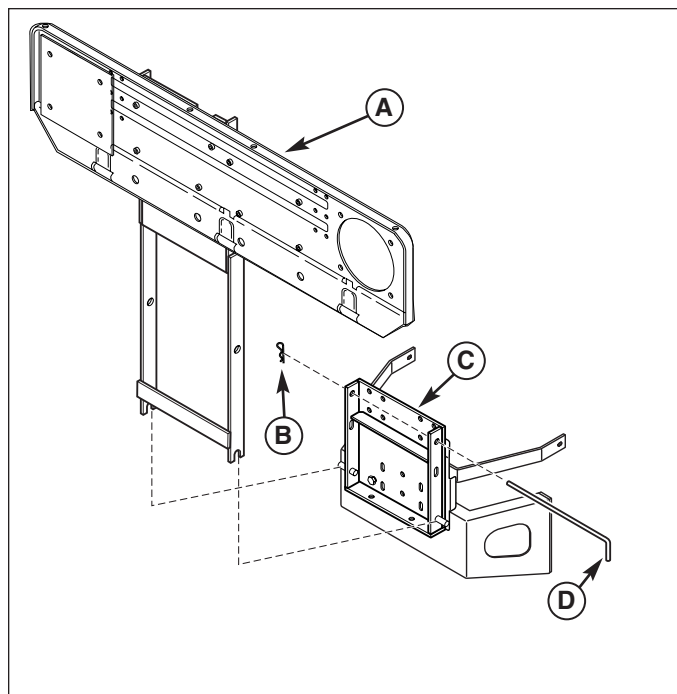

Figure 3. Install Back Plate (Flat Style Bumper shown)

- A. Back Plate & Support
- B. Hair Pin
- C. Hitch Plate
- D. Rod

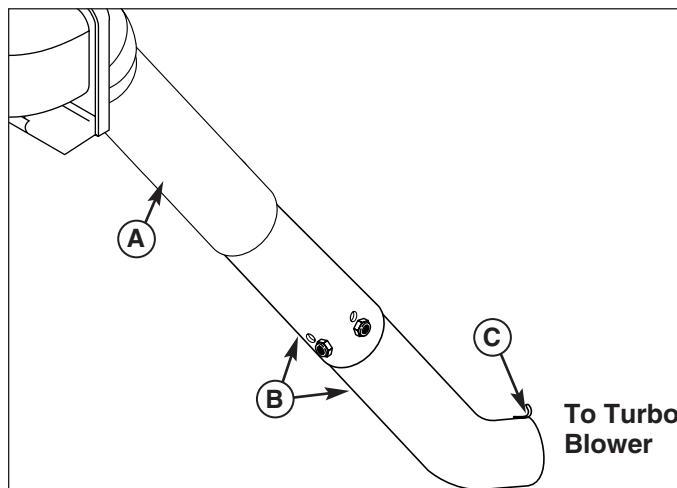

Figure 4. Assemble Tubes

- A. Upper Tube
- B. Middle & Lower Tube
- C. Clip

WARNING

OPERATION WITHOUT TURBO & CATCHER

For operation without turbo, the mower deflector **MUST** be properly installed in the down position and retained by the spring latch (see turbo operator's manual).

Removing and Re-attaching Grass Catcher

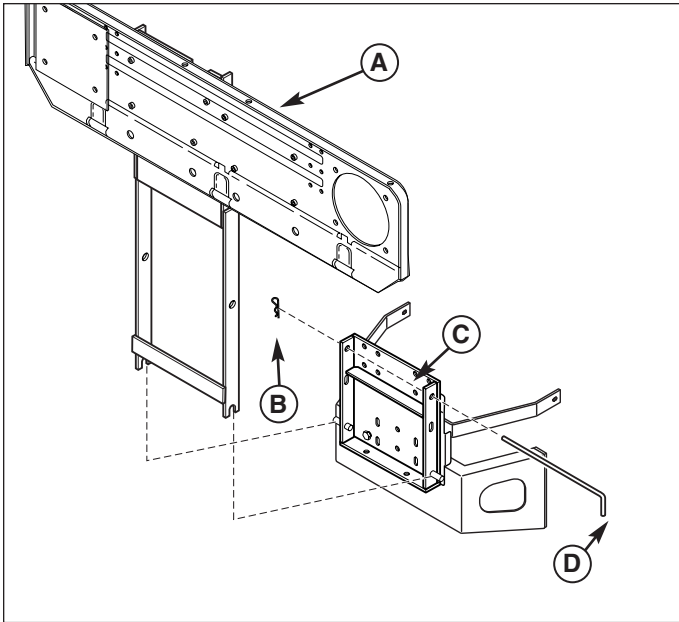

Figure 5. Install Back Plate (Flat Style Bumper shown)
A. Back Plate & Support C. Hitch Plate
B. Hair Pin D. Rod

Re-attaching the Grass Catcher

1. Set the back plate and support (A, Figure 5) onto pins of hitch plate (C). Secure with rod (D) and hair pin (B).
3. Hook the bags (A, Figure 6) on the back plate(B).
4. Install the catcher cover (A, Figure 7 & 8) and secure with the hinge pins (B) and hair pin clips (D).

NOTE: Push the hair pin clips all the way on or they will be bent by the hinge when the cover is opened.

5. Insert middle & lower tube (B, Figure 4) into upper tube (A) and clip (C) onto turbo.

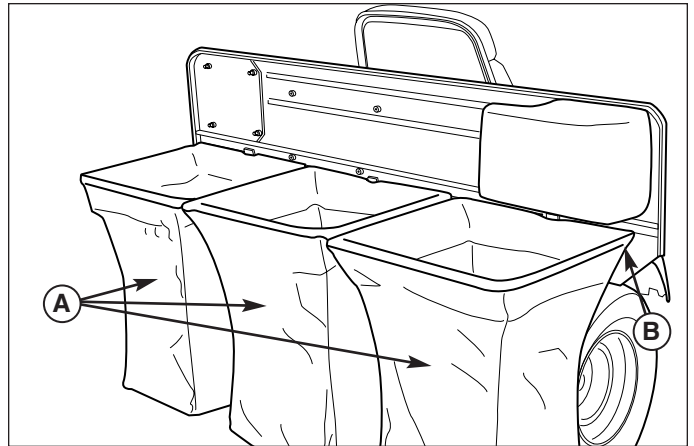

Figure 6. Bags
A. Bags
B. Back Plate

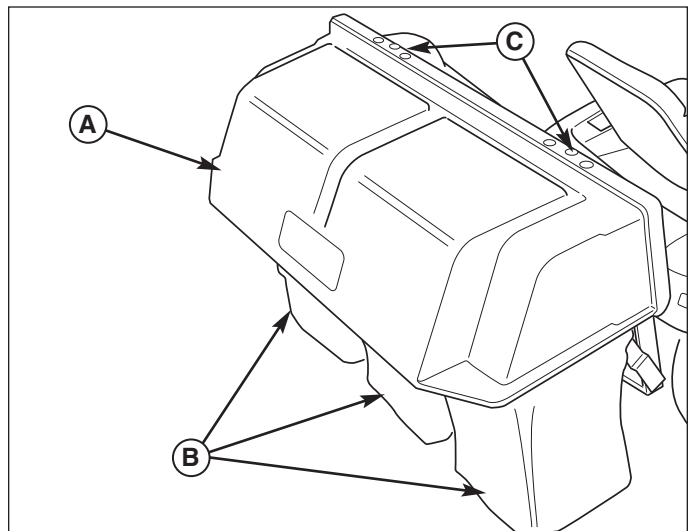

Figure 7. Install Cover
A. Cover
B. Bags
C. Hinges

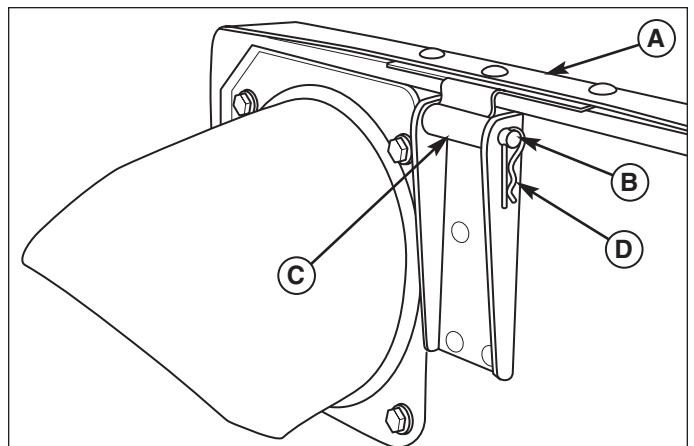

Figure 8. Install HInge Pins
A. Cover
B. Hinge Pin
C. Hinge
D. Hair Pin Clip



MANUFACTURING, INC.
500 N Spring Street / PO Box 997
Port Washington, WI 53074-0997

www.SimplicityMfg.com



Simplicity Mfg. Inc. - Snapper Products
535 Macon Street
McDonough, GA 30253

www.Snapper.com



Simplicity Mfg. Inc. 500 N Spring
Street / PO Box 997
Port Washington, WI 53074-0997

www.MasseyLawn.com

© Copyright 2006 Simplicity Manufacturing, Inc.
All Rights Reserved. Printed in USA.