

Safety Instructions & Operator's Manual for

SNAPPER®

ZERO TURNING RADIUS RIDING MOWER

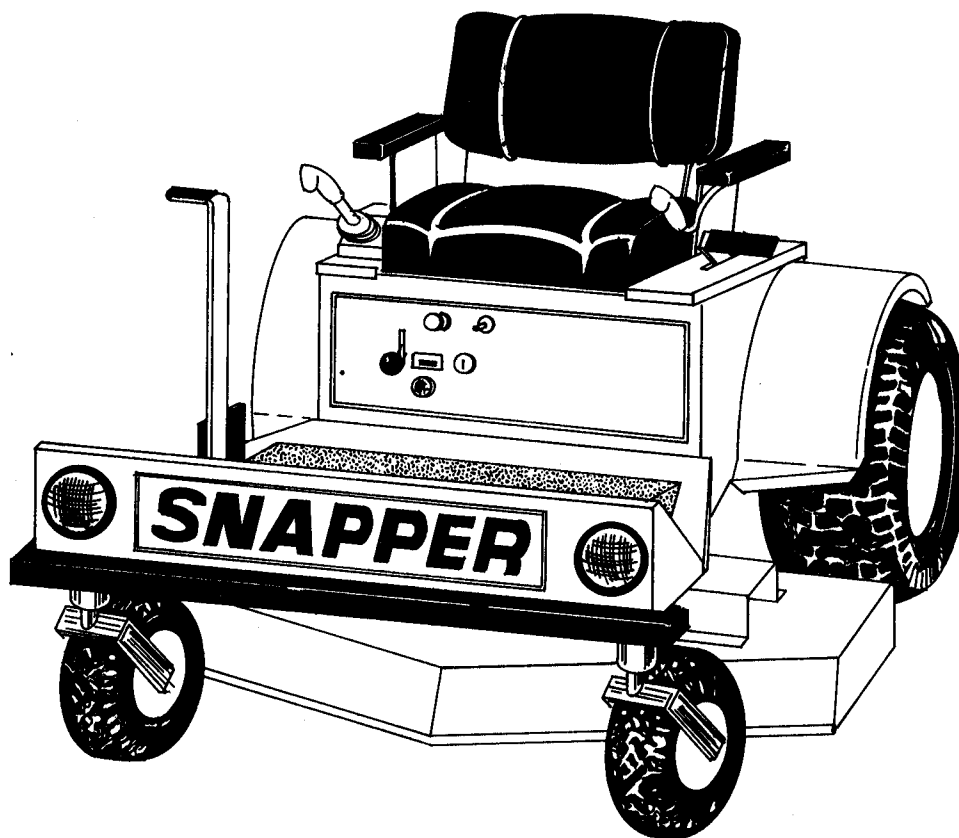

Thank you for buying a SNAPPER product! Your SNAPPER Zero Turning Radius Riding Mower was designed and built to provide long and satisfactory service. Keep in mind that it, like any other mechanical device, can be potentially dangerous if used improperly and that no accident prevention program can be successful without the wholehearted co-operation of the person responsible for the operation of the equipment. Study this manual and pay particular attention to the important Safety Precautions on pages 1-4. Following these instructions will help you continue to enjoy the trouble-free performance expected of a SNAPPER product.



SNAPPER POWER EQUIPMENT

McDonough, GA • 30253



79480

P-10574

SNAPPER ZERO TURNING RADIUS RIDING MOWER

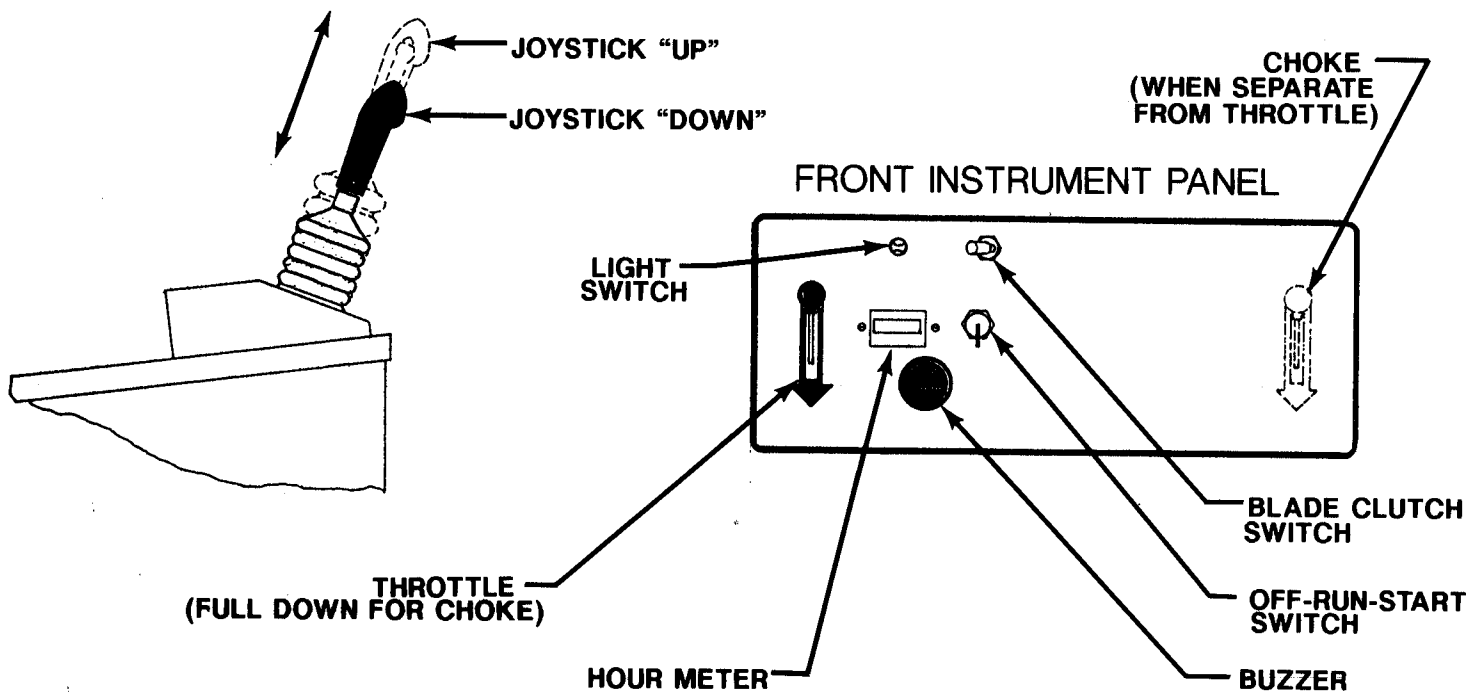
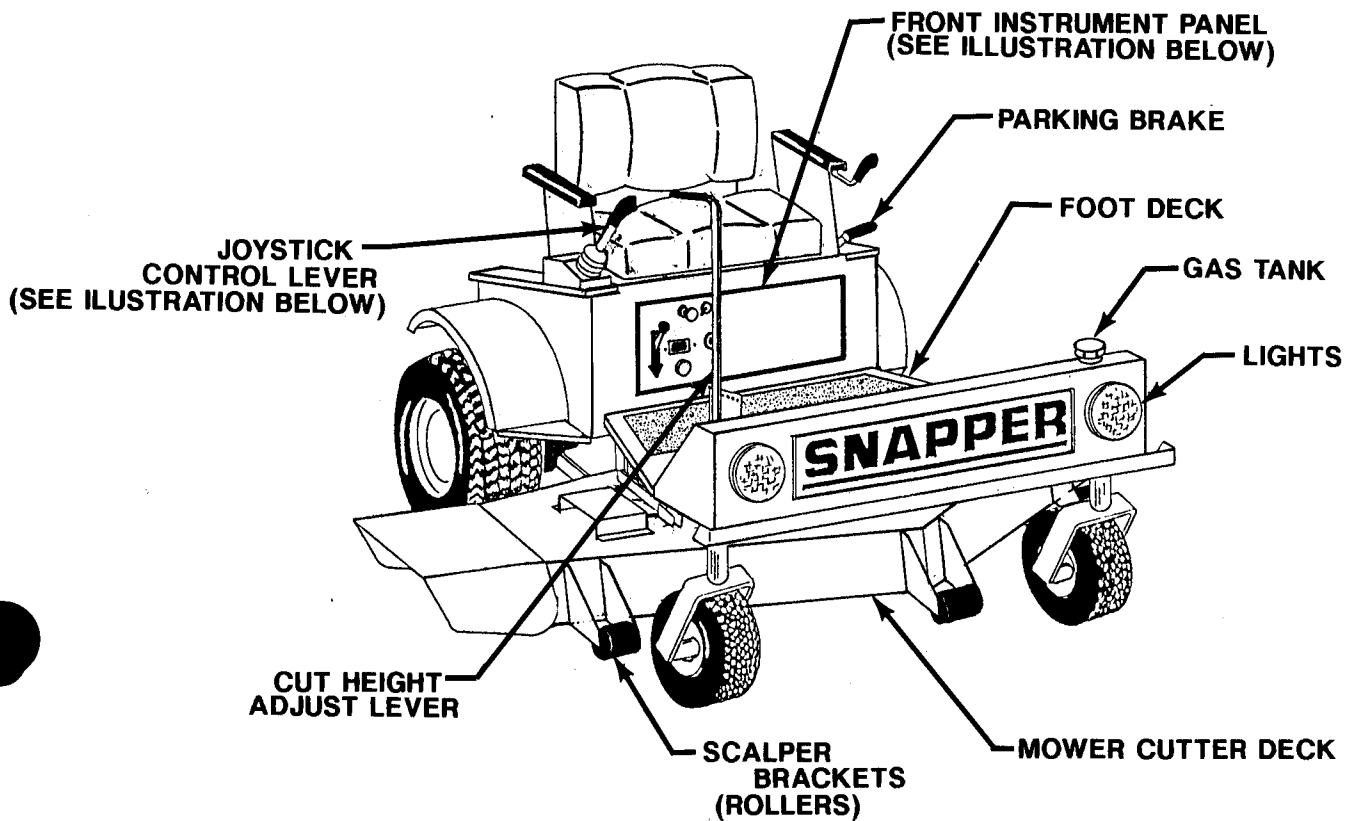

TABLE OF CONTENTS

I. SAFETY

 Accident Patterns ----- 1

 Safety Instructions and Recommendations ----- 2

 Safety Interlock System ----- 4

II. START-UP AND OPERATION

 Checklist Before Operation ----- 5

 Control Locations ----- 6

 Operation ----- 6

 Mowing Recommendations ----- 9

III. SPECIFICATIONS -----10

IV. MAINTENANCE

 Maintenance Schedule ----- 11

 Maintenance Instructions ----- 12

 Trouble-shooting Checklist ----- 18

 Wiring Schematic ----- 21

V. OWNER INFORMATION ----- 22

SAFETY

Accident Patterns to Avoid

- I. CONTACT WITH THE ROTATING BLADE--This accident usually happens when the operator is clearing the discharge chute of grass, (especially when the grass is wet), or when the operator adjusts the machine without turning it off and waiting for the blades to completely stop.
- II. PROPELLED OBJECTS--Sticks, rocks, wires and other objects can be propelled out through the discharge chute or from under the mower housing. Bystanders are particularly vulnerable.
- III. GRASS CATCHER OR GUARD--The mower shall not be operated without either the entire grass catcher or the guard in place.
- IV. OVERTURNING--This happens when riding mowers are used on steep slopes, embankments or hills. The operator in these cases can come in contact with the blades or sustain injuries during a fall.
- V. MOWER RUNNING OVER THE VICTIM--The accident victims are most often young children whom, unseen by the operator of the mower, were in the area being mowed.

AT SNAPPER, WE SHARE YOUR DESIRE TO PROTECT YOURSELF, YOUR FAMILY, YOUR FRIENDS AND YOUR NEIGHBORS FROM ACCIDENTAL INJURY. OBSERVING AND ENFORCING THE FOLLOWING GUIDELINES WILL HELP TO INSURE THE SAFETY OF EVERYONE. PLEASE BE CAREFUL!

SAFETY INSTRUCTIONS AND RECOMMENDATIONS

1. PEOPLE WHO OPERATE, SERVICE, OR ARE OTHERWISE ASSOCIATED with the Snapper Zero Turning Radius Riding Mower should be trained in its proper use and warned of its dangers. Before operating, adjusting, or servicing, they should read and understand this entire manual and the owner's engine manual.
2. AVOID CONTACT WITH MOVING PARTS. Keep hands and feet from under mowing deck and away from blades at all times. Turn engine (motor) off if you must unclog the chute.
3. KEEP YOURSELF AND ALL OTHERS AWAY FROM THE DISCHARGE CHUTE at all times. Never direct the discharge of material toward bystanders. NEVER ALLOW ANYONE NEAR THE MACHINE WHILE IN OPERATION.
4. AVOID HILLS AND SLOPES. Use extreme caution when mowing up or down slopes. NEVER mow across the face of a slope. If a slope must be ascended, back up the slope; drive forward when descending. Reduce speed and use caution to start, stop and maneuver. To prevent loss of control on a slope avoid sharp turns, sudden changes in direction, and sudden stops and starts.
5. DISENGAGE POWER TO MOWER BEFORE BACKING UP. Do not mow in reverse unless ABSOLUTELY necessary and then only after turning around and observing the entire area behind the mower. Go slowly.
6. BEGINNING OPERATORS SHOULD LEARN HOW TO STEER the Snapper Zero Turning Radius Lawnmower before attempting to mow. Start with slow engine speed and drive without the blades engaged in open area until comfortable with the machine.
7. KNOW HOW TO STOP QUICKLY. Know the location and operation of every control, especially how to brake and how to disengage the mower blades.
8. DO NOT MOVE THE JOYSTICK CONTROL LEVER rapidly. The speed and direction of travel is affected instantly by the movement of the joystick.
9. DO NOT ALLOW CHILDREN TO OPERATE MOWER. Do not allow others who have not had instruction to operate mower.
10. ALWAYS TURN ENGINE OFF AND REMOVE THE KEY before leaving the mower to prevent children and inexperienced operators from starting the engine. Never leave the mower unattended with engine running. Always wait for all moving parts and all sounds to stop before leaving the operator's seat. Always set the parking brake on an unattended mower.

11. WEAR STURDY, ROUGH-SOLED WORK SHOES AND CLOSE-FITTING SLACKS and shirts. Never operate the mower in bare feet, sandals or sneakers.
12. NEVER CARRY PASSENGERS.
13. KNOW THE AREA YOU ARE TO MOW. Watch for hidden dangers such as rocks, roots, sticks, holes, bumps and drop-offs, etc. Before mowing, pick up all debris in area to be mowed. Sharp and hard objects can be propelled at a high speed and can act like shrapnel. Walk through tall grass BEFORE MOWING to make sure there are no hidden dangers. Mow higher than desired in tall grass to expose any hidden objects and/or obstacles, clean the area, and then mow to the desired height.
14. NEVER REFUEL A MOWER INDOORS. Allow the engine time to cool before refueling. Unseen vapors may be ignited by a spark. Always clean up spilled gasoline. Never run the engine indoors in a garage or any other closed building. Allow engine to cool before storing in any enclosure. The engine exhaust and the gasoline fumes are dangerous.
15. NEVER REMOVE THE FUEL CAP or add gasoline to a running or hot engine or an engine that has not been allowed to cool for several minutes after running. Always make sure the gas cap is in place.
16. DON'T SMOKE AROUND THE MOWER or the gasoline storage container. Gasoline fumes can easily ignite.
17. KEEP GASOLINE IN A WELL-VENTILATED AREA away from your living quarters and in tightly-capped safety cans. Never store mower with gasoline in the tank inside a building where fumes may reach an open flame or spark.
18. DISENGAGE BLADE, STOP ENGINE AND REMOVE IGNITION KEY before any servicing. Be sure all moving parts and all sounds have stopped. Let engine cool and disconnect the spark plug or plugs so the engine cannot start by accident. A SLIGHT ROTATION OF THE BLADE COULD START THE ENGINE.
19. KEEP ALL NUTS, BOLTS, AND SCREWS TIGHT to be sure equipment is in safe working condition, especially blade mounting bolts.
20. VEHICLE SHOULD BE STOPPED AND INSPECTED FOR DAMAGE after striking a foreign object and the damage should be repaired before restarting and operating the equipment. Stop immediately and check for damage or loose parts if mower should start vibrating.

21. DISENGAGE BLADES BEFORE DRIVING ACROSS WALKS or projecting objects.
22. KEEP SAFETY DEVICES IN PLACE.
23. DON'T STEP OR STAND ON THE MOWER HOUSING; STEP OR STAND ONLY ON THE FOOT DECK.
24. WATCH OUT FOR TRAFFIC near roadways and when crossing roads.
25. THIS MACHINE IS NOT MEANT FOR HIGHWAY or street use. It is not a recreational vehicle and it should not be operated as such.
26. DO NOT USE MOWER WHEN GRASS IS WET OR SLIPPERY.
27. KEEP MACHINE AND ENGINE FREE OF GREASE, dirt, grass, leaves and other foreign build-up to reduce overheating and a possible fire hazard.
28. MOW ONLY DURING DAYLIGHT.
29. ALWAYS DISENGAGE THE MOWER BLADE CLUTCH when transporting.

SAFETY INTERLOCK SYSTEM

Your Snapper Zero Turning Radius Riding Lawnmower is equipped with three sets of switches interlocked for your safety.

1. The mower blades must be disengaged before the engine will start.
2. The Joystick control lever must be in neutral "down" position before engine will start.
3. The engine will stop if the mower clutch is engaged when the operator leaves the driver's seat.
4. The engine will stop if the Joystick control lever is not in the neutral "down" position when the operator leaves the driver's seat.

DO NOT OPERATE MOWER IF THESE SWITCHES ARE NOT OPERATING PROPERLY

Control Locations

Ignition Key - Center in front of seat.

Engine Throttle - RH side in front of seat.

Joystick Steering/Speed Control Lever - Above fender on right side.

Blade Clutch Switch - Center in front of seat.

Parking Brake Lever - LH side beside seat.

Blade Height Adjustment Lever - RH side of deck on floor.

Choke - On LH side in front of seat. On Choke-A-Matic models, choke is at full throttle position of throttle.

Transmission Unlock - A push rod with a rotating cam actuator is located at the front of the left hydrostat and at the rear of the right hydrostat.



```
*****
*                                     *
*          ▲ WARNING ▲               *
*   AVOID INHALING EXHAUST FUMES--CARBON MONOXIDE *
*   GAS IS COLORLESS AND ODORLESS, AND CAN CAUSE *
*   UNCONSCIOUSNESS, AND IS POTENTIALLY LETHAL. *
*   DO NOT RUN LAWN MOWER IN GARAGE OR OTHER *
*   CONFINED AREA. *
*****
```

TO START



1. MOVE JOYSTICK CONTROL LEVER to neutral "down" position by centering it and pushing it down.
2. SET PARKING BRAKE: Pull rearward to set.
3. DISENGAGE MOWER BLADE clutch by moving clutch switch to OFF (right) position.
4. SET ENGINE CHOKE CONTROL for cold starts to full choke position near bottom of control.
5. SET ENGINE THROTTLE CONTROL to "Start" position (near top of control). (For combined choke/throttle, use choke setting)
6. TURN IGNITION KEY to "on" position and release to "run" as soon as engine starts. NOTE; Prolonged cranking will damage starter motor and shorten the battery life.
7. ADJUST ENGINE THROTTLE AND CHOKE for desired engine smoothness and speed.
8. RELEASE PARKING BRAKE: Push brake lever forward to release.

 * IMPORTANT: If the operator is inexperienced with the *
 * Joystick zero turning radius steering/speed control, *
 * he/she should follow these recommendations: Disengage *
 * the mower blades. Go very slowly until thoroughly *
 * familiar with the machine. Keep away from fences, *
 * buildings, and other obstructions. While becoming *
 * familiar with the machine, move the Joystick smoothly *
 * and slowly. Practice until operation is smooth and *
 * efficient. *

9. TO DRIVE: Move the Joystick steering/speed control lever to the "up" position. Move the Joystick forward to move forward. Move the Joystick slowly forward to increase speed. To reverse direction, pull the Joystick slightly back. To turn, move the Joystick toward the direction you want to turn. To turn on a zero radius axis, go slowly and move the Joystick to the side you wish to turn.



 *  CAUTION  *
 * FOR SMOOTH, SAFE OPERATION, MOVE THE JOYSTICK IN A *
 * GENTLE, SLOW MOTION. NEVER PULL OR PUSH THE *
 * JOYSTICK RAPIDLY, ESPECIALLY ON GRADES. *

10. BRAKING: To brake mower, gently move the Joystick in the direction opposite to travel. In an emergency, the parking brake may be used in conjunction with the natural braking of the Joystick.
11. CUTTING HEIGHT ADJUSTMENT: Rotate the Cut Height Adjust Lock and move the Cut Height Adjust Lever to the right to clear the peg holes. Adjust HIGHER by moving the lever rearwards. Adjust LOWER by pushing the released lever forward. Reset the Cut Height Lever in the Peg hole and Rotate the Cut Height Adjust Lock to secure it.
12. ENGAGE MOWER BLADE CLUTCH by pulling out on the blade clutch switch lever then moving the lever to the on position. The engine will not start if the blade clutch is engaged. If the operator is not in the seat, the engine will stop if the clutch is engaged.

 *  CAUTION  *
 * AVOID HILLS AND SLOPES. USE EXTREME CAUTION WHEN *
 * MOWING UP OR DOWN SLOPES. NEVER MOW ACROSS THE FACE *
 * OF A SLOPE. IF A SLOPE MUST BE ASCENDED, BACK UP THE *
 * SLOPE; DRIVE FORWARD WHEN DESCENDING. *

MOWING RECOMMENDATIONS

1. Keep mower blades sharp.
2. Make sure deck and discharge chute are clean.

```
*****  
*                                     *  
*           CAUTION           *  
*          ENGINE MUST BE OFF TO CLEAN CHUTE          *  
*                                     *  
*****
```

3. When mowing tall grass, make two passes, mowing off 1/2 the grass height the first pass, and then the desired height the second pass. Check for hidden dangers first.
4. Go slowly for trimming.
5. Always cut grass with the engine at 3/4 to full throttle speed. This ENGINE speed allows the cutting blades to operate at optimum cutting speed. Control GROUND speed with the Joystick.

SPECIFICATIONS

Length
Model Z1251BVJ ----- 73"

Width ----- 48"
with Z4201M Deck including Chute ----- 53"

Height ----- 38"

Weight ----- Approx. 650 lbs.

Cutting Width ----- Z4201M Deck ----- 42"

Cutting Height ----- 1-3/4" to 4"

Blades ----- Z4201M Deck 3 - 15" Blades

Fuel Tank ----- 4 Gallon

Note: Tank has approximately 2 gal. reserve when
gauge shows empty.

Hydrostats ----- Eaton #7

Engine:
Model Z1251BVJ -12.5 HP one cyl Briggs Vanguard

Engine to Hydrostat Belt:
Models Z1251BVJ ----- A 56

Engine to Mower Deck Belt:
Models Z1251BVJ -----42" Deck B 84

Mower Deck Belt ----- 42" Deck L496

Hydrostat to Jack Shaft ----- #40 Chain

Jack Shaft to Wheel ----- #50 Chain

Mower Deck ----- 42" 14 Gauge steel

All decks reinforced with 3/16" spindle plate

Blade Spindles ----- 1" HD bearings
top and bottom

Front Tire:
Model Z1251BVJ ----- 4.10/3.50 x 4

Drive Tire:
Model Z1251BVJ ----- 18/9.50 X 8

MAINTENANCE

 *
 * ⚠ CAUTION ⚠ *
 * BEFORE PERFORMING ANY MAINTENANCE, TURN OFF ENGINE, *
 * REMOVE KEY AND DISCONNECT SPARK PLUG OR PLUGS. USE *
 * EXTREME CARE WHEN WORKING ON MACHINERY. DO NOT WEAR *
 * WATCH OR JEWELRY, DO NOT WEAR LOOSE FITTING CLOTHES, *
 * AND OBSERVE ALL COMMON SAFETY PRACTICES WITH TOOLS. *

MINIMUM MAINTENANCE SCHEDULE

Service	When
check crankcase oil level	before each use
clean air intake screen	after each use
clean grass under deck	after each use
check tire pressure	every 10 hours
check battery fluid	every 10 hours
sharpen mower blades	every 10 hours
clean air filter element	every 10 hours
check hydrostatic transmission fluid	every 25 hours
change engine crankcase oil	every 25 hours (5 hrs. break-in)
check drive belts (3)	every 25 hours
check drive chain tension/lubricate	every 25 hours
replace air filter element	yearly or 100 hours
check spark plug	yearly or 100 hours
service battery	yearly or 100 hours
lubricate all fittings	yearly or 100 hours
replace fuel filter or filters	yearly or 100 hours
change hydrostatic transmission fluid	2yrs. or 500 hrs
decals	Replace when illegible

Under extreme operating conditions, service and maintenance may be required more frequently than shown.

MAINTENANCE INSTRUCTIONS

1. ENGINE:

For complete maintenance and operating information for your engine, please refer to your engine operating and maintenance instructions furnished by the engine manufacturer and included in your Snapper Zero Turning Radius Riding Lawnmower information packet.

NOTE: Air intake screen must be kept clean. If plugged, engine may be seriously damaged by over heating.

2. BATTERY:

```
*****
*                                     *
*          ▲ CAUTION ▲               *
*   Battery electrolyte is a poisonous and corrosive *
*   sulfuric acid solution. Avoid spilling on skin,  *
*   eyes and clothing.                             *
*****
```

Keep the electrolyte level above the plates in each cell by adding distilled water as it becomes necessary. Add water just before operating the mower to mix the water with the solution. Be careful not to overfill the battery--the electrolyte solution is corrosive and can cause damage to surrounding metal parts if it should spill. Keep your battery at 1.260 specific gravity charge. When taking the battery out of the mower for servicing, make sure to connect the cables to the battery exactly as they were prior to removal.

Keep the battery clean. Remove corrosion around the battery terminals by applying a solution of one part baking soda to four parts water. Coat all exposed terminal surfaces with a light layer of grease or petroleum jelly to prevent corrosion.

```
*****
*   NOTE: At temperatures below 32 degrees F (0 deg C) *
*   the full charge state must be maintained to prevent *
*   cell electrolyte from freezing and causing permanent *
*   battery damage.                                     *
*****
```

3. Tires

Correct tire pressure is essential for efficient operation of the mower. Check tire pressures periodically. Inflate tires to the pressures listed below:

Tire pressure:	Front tires	Rear tires
Models Z1251BVJ -----	24 psi	12 psi

Lug nuts or lug bolts should be regularly checked for tightness.

4. Mower Blades

Check sharpness of mower blades after every 10 hours of operation. To sharpen the blades proceed as follows:

```
*****
*                                     *
*          ▲ CAUTION ▲               *
*   STOP ENGINE AND REMOVE IGNITION KEY   *
*                                     *
*****
```

- A. Remove bolt, lockwasher, and cup washer mounting blade on shaft. Remove blade.
- B. Sharpen blade with a hand file, electric grinder or an electric blade sharpener. Wear gloves and eye protection when sharpening. Grind blade at original bevel.
- C. Check balance of blade by positioning the blade on a nail or blade balance pedestal. Grind the blade on the end that is heavier, until both sides balance.
- D. Install blade, cup washer, lockwasher and bolt. Make sure to tighten the bolt to 60ft.-lbs.

5. Chain Drives

To check and/or adjust the tension of the roller chains:

- A. Remove the wheel fender(s).
- B. Both drive chains on each side should be tensioned to flex 1/4-1/2" at the midspan of the slack side.
- C. The tension on both chains may be adjusted by loosening the four bolts which mount the idler sprockets and adjusting the idler sprockets upward/downward or forward/backward. Retighten all bolts securely. (It may require two people to make this adjustment; one to hold the bracket while the other tightens the bolts.
- D. Replace the wheel fender(s).

6. V-Belts

There are 3 V-belts on your Snapper Zero Turning Radius Riding Lawnmower. The two deck belts are equipped with spring-loaded belt tighteners and do not require tightening adjustments. They should be checked after every 25 hours of use to make sure they are in good condition. Replace any belts found to be in poor condition. See the specifications on page 10 for belt sizes.

7. Lubrication

A. Engine

Follow engine manufacturer's recommendations.

B. Wheels

Lubricate front wheel axles after every 25 hours of operation.

C. Drive Chains

Lubricate drive chains every 25 hours of operation. Use a dry graphite lubricant only--do not use oil or grease as these attract dust and dirt and actually make the chains wear faster than no lubrication at all.

D. Hydrostatic Transmission:

Checking and Replenishing Oil

```
*****  
*          DIRT OR WATER IN OIL CAN RUIN          *  
*          THE HYDROSTATIC TRANSMISSION          *  
*****
```

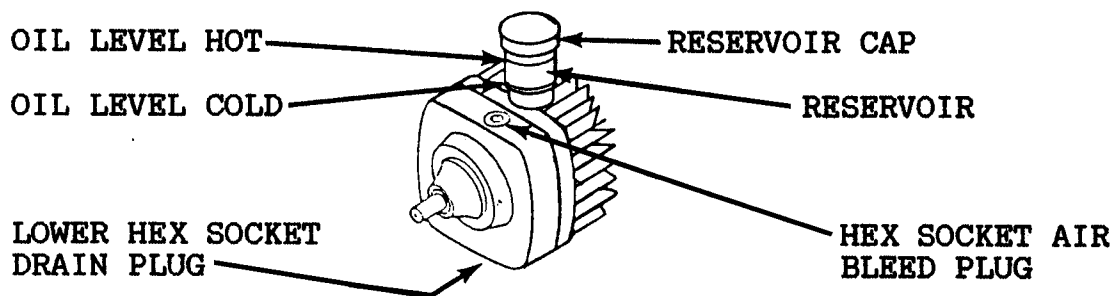

1. Check the oil level on each hydrostat after every 25 hours of usage. Replenish as needed with SAE 20W20 or SAE 30 premium engine crankcase oil.
 - a. Remove oil reservoir cap.
 - b. Fill to lines marked on oil reservoir.
 - c. Do not over fill.
 - d. When checking oil level be very careful to keep the reservoir clean and to fill only with clean oil.

2. It is not necessary to change the oil on a regular basis, however, after repair the transmission should be refilled as follows:
 - a. Reinstall bottom hex socket drain plug.
 - b. Refill transmission with SAE 20W20 or SAE 30 through reservoir until oil flows out of the bleed plug. Cupping your hand and patting open top of reservoir will force oil through filter in reservoir. Do not puncture filter.
 - c. Replace the air bleed plug and fill reservoir to fill line.
 - d. Start engine and add oil as required to maintain level in reservoir. Replace oil reservoir cap.
 - e. Check reservoir level after running 1/2 hour.

8. Parking Brake Adjustment

To adjust the parking brake, remove the right fender, remove the thumbscrew swivel nyloc nut and turn the thumbscrew swivel to lengthen or shorten as needed. Do not overtighten. Replace thumbscrew swivel nyloc nut. Tighten so nyloc engages the bolt completely but do not lock up the thumbscrew swivel. Use the same procedure to adjust the left parking brake.

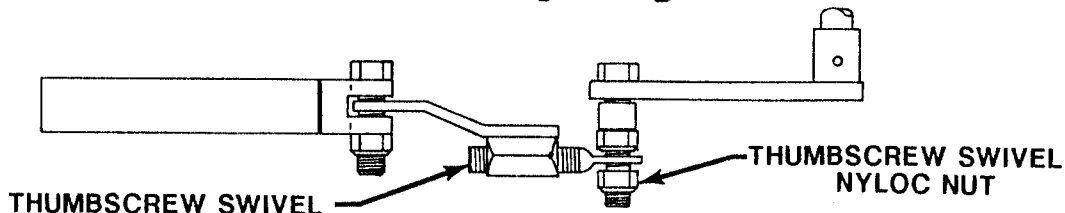

9. Hydrostatic Transmission

After every 10 hours of operation, lift the seat and be sure that the cooling fins of the hydrostatic transmission are clean. Never wash across top of reservoir with water or steam. Excessive accumulation of oil, dirt, or trash may cause the transmission to overheat. Lubricate transmission as per guidelines under Hydrostatic Transmission "Lubrication" section of this manual. (page 14)

10. Scalper roller bolts

Scalper roller bolts should be tightened until the spacing bushing will not turn relative to the scalper bracket to prevent undue wear on the end of the spacer bushing and the scalper bracket. The proper torque is from 17 to 20 ft.lb.

11. Hydrostat drive belt tension adjustment

In normal use the hydrostat drive belt tension should be checked after the first 25 hours of use for normal wear in and stretch. It may be adusted as follows:

- a. Loosen the two slide locking bolts until the pulley idler slide can be just moved relative to the mounting bracket.
- b. Tighten the tension adjust bolt until the belt is tight enough to prevent belt slippage. Belt should deflect approximately $3/8$ " to $5/8$ " under moderate pressure. Do not over tighten.
- c. Retighten the two slide locking bolts.

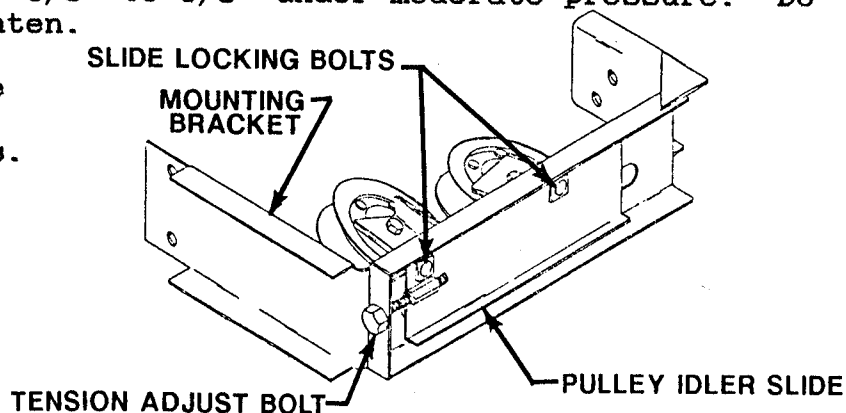

12. Hydrostat-Joystick Neutral Adjustment

With the engine running, if the machine travels in either direction when the Joystick is in the neutral "down" position, stop the engine, elevate the rear wheels clear of the ground and adjust as follows:

A. Hydrostat Neutral Adjustment:

Right side:

- a. Place Joystick in the neutral "up" position.
- b. Loosen the right eccentric pivot pin locking set screw until it is just snug on eccentric pivot pin.
- c. Start the engine.
- d. Rotate the right eccentric pivot pin until the wheel stops turning.
- e. Stop the engine.
- f. Tighten the right eccentric pivot pin set screw.
- g. Start engine and if right wheel rotates, repeat steps b through g.
- h. Stop engine.

Left side: Repeat steps a through h for the left side.

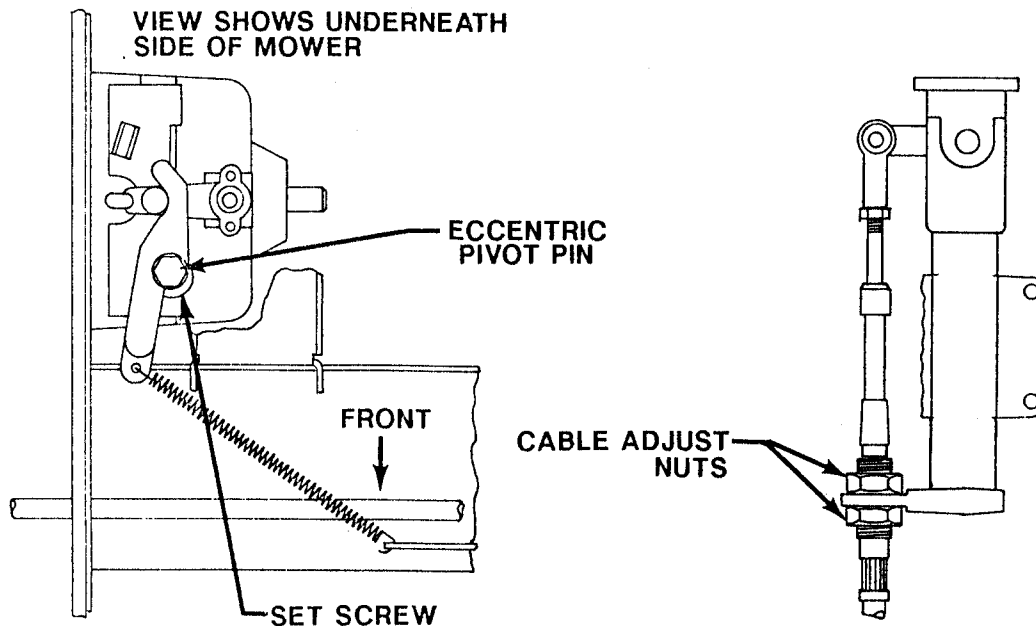

B. Joystick neutral adjustment:

- a. Hydrostat neutral must be adjusted first. See above.
- b. Remove right fender.
- c. Place Joystick in the neutral "down" position.
- d. Start engine.
- e. Loosen cable adjust nuts and adjust until wheels do not turn. Tighten adjust nuts. Note: The outside cable controls the right wheel and the inside cable controls the left wheel.
- f. Stop engine.
- g. Replace right fender.

JOYSTICK LUBRICATION AND DETENT ADJUSTMENT

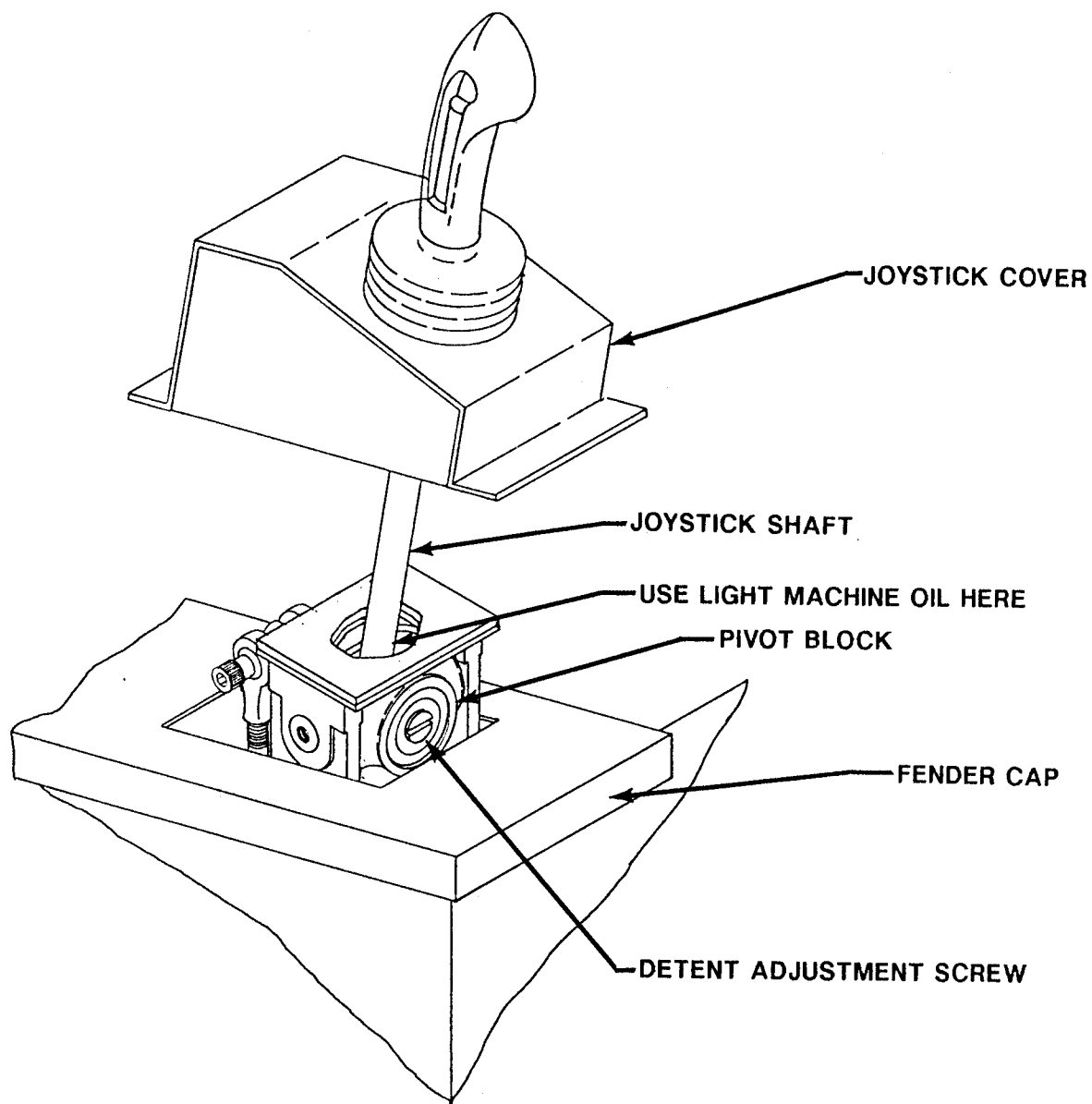

Remove Joystick Cover from Fender Cap.

Place a few drops of light machine oil on Joystick Shaft where it enters the Pivot Block then work joystick up and down and rotate it distribute oil around the Joystick Shaft and into the Pivot Block.

If Joystick does not lock in the "up" position, turn the Detent Adjustment Screw clockwise until a desirable locking action is obtained.

If Joystick is hard to slide up and down, turn the Detent Adjustment Screw counter-clockwise until a desirable sliding action is obtained.

Trouble Shooting Checklist

1. Engine won't turn over.

Mower blades engaged:-----	disengage blades.
Joystick not in neutral "down" position: -----	move Joystick to neutral "down".
Blown fuse: -----	replace fuse.
Dead battery:-----	charge or replace.
Solenoid:-----	consult dealer.
Ignition switch:-----	consult dealer.
Starter:-----	consult dealer.

2. Engine will turn over; won't run.

No gas:-----	refuel. clean or replace fuel filters
Fuel valve closed:-----	open fuel valve.
Over or under choked-----	adjust choke.
Spark plug not firing:-----	check spark plug condition and reset gap.*
Electronic ignition faulty: -----	consult dealer.
Carburetor maladjustment:-----	reset carburetor adjustment.*
Ignition switch:-----	consult dealer.

3. Hard to start engine.

Fuel line clogged:-----	clean fuel line and check strainer in fuel tank.
Faulty fuel pump:-----	consult dealer.
Spark plug wire grounded or loose:-----	check spark plug wires.
Spark plug faulty or improperly gapped:-----	check spark plug condition and reset gap.*
Electronic ignition faulty -----	consult dealer.
Dirty or maladjusted carburetor:-----	readjust carburetor* or consult dealer for carburetor service.

* NOTE: See engine manual for engine adjustments.

4. Engine starts, but cuts out.

Water in gas:-----	drain and replace with new gas.
Clogged fuel line:-----	check strainer in fuel tank and clean fuel line.
Vent in fuel cap plugged:-----	check vent.
Faulty fuel pump:-----	consult dealer.
Maladjusted carburetor:-----	readjust carburetor.*

5. Engine knocks.

Low oil level:-----	add oil.
Ignition timing off:-----	consult dealer.
Fuel octane too low:-----	drain and re- place with higher octane gas.
Overheated engine:-----	shut off and allow to cool.

6. Engine sometimes skips at higher speeds.

Incorrect ignition timing:-----	consult dealer.
Carburetor maladjustment:-----	readjust carburetor.*
Faulty, fouled or incorrectly gapped plug:-----	check and gap spark plug.

7. Engine overheated.

Air intake screen or fins clogged:-----	clean intake screen and fins.
Fuel mixture too lean:-----	readjust carburetor.*
Oil level too low or too high:-----	adjust oil level as necessary.
Improper ignition timing:-----	consult dealer.

* NOTE: See engine manual for engine adjustments.

8. Engine idles poorly.

Carburetor maladjustment:----- readjust carburetor.*
Improper spark plug gap:----- check and gap spark plug.*

9. Engine backfires.*

Carburetor maladjustment:----- readjust carburetor.*
Faulty ignition system ----- consult dealer.

NOTE: Engine backfire on shutoff is common.

10. Engine runs, but mower won't move forward.

Transmission locks in unlock position:----- put into lock position.
Drive belt broken:----- replace.
Transmission oil low: ----- add oil.
Air in transmission: ----- bleed air, see page 14.
Not enough tension on drive belt: ----- check.
Bad transmission:----- consult dealer.

11. Mower loses power or transmission overheats.

Hydro. trans. oil too low or too high:----- adjust as necessary.
Transmission damage:----- consult dealer for service.

12. Engine stalls when blades are engaged.

Operator not on seat: ----- sit on seat.
Faulty interlock system:----- consult dealer.
Bad blade spindle bearings:----- consult dealer.
Drive belt not properly routed:----- re-route.
Blades blocked by foreign material:----- clean under deck

* NOTE: See engine manual for engine adjustments.

WIRING SCHEMATIC

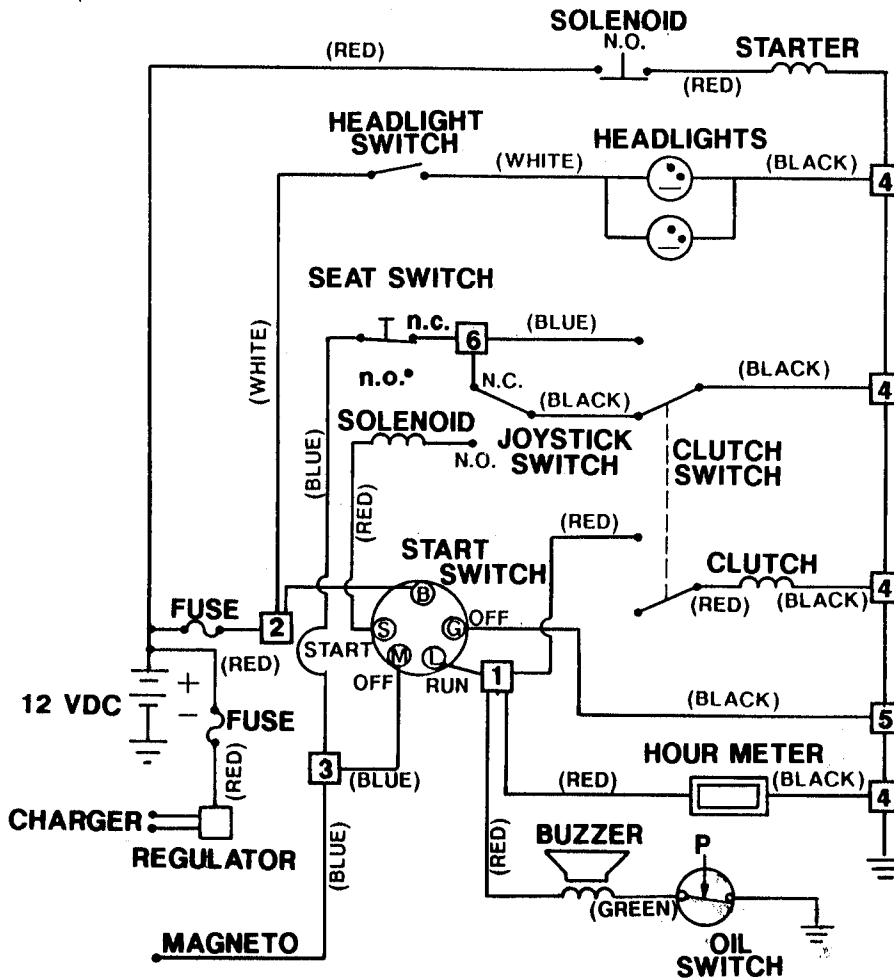
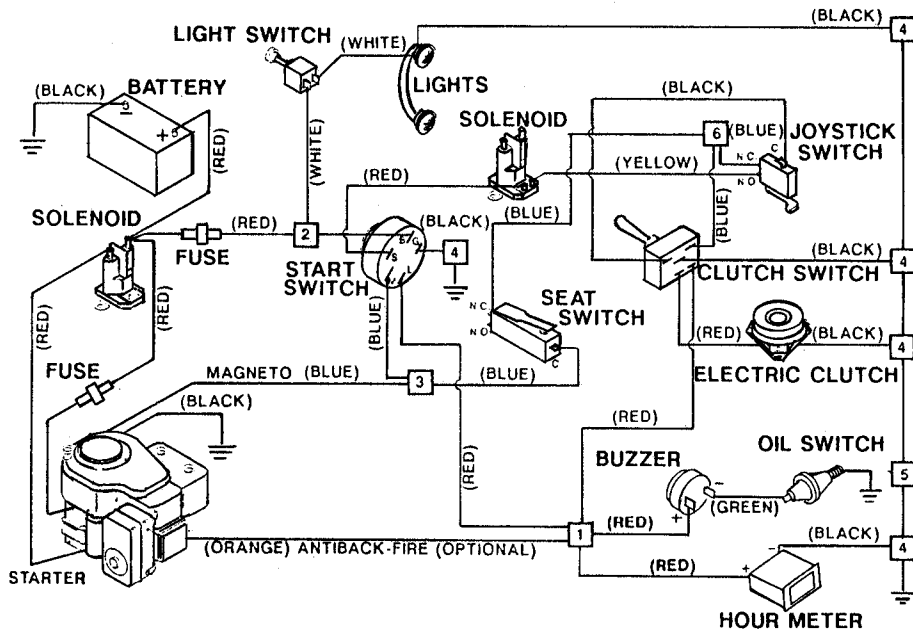

SERIAL NUMBER LOCATIONS

1. Mower frame serial number is located on right rear side of frame beside engine.
2. Deck serial number is located on left front side of mower deck housing.
3. Engine code number is located on back center of engine.

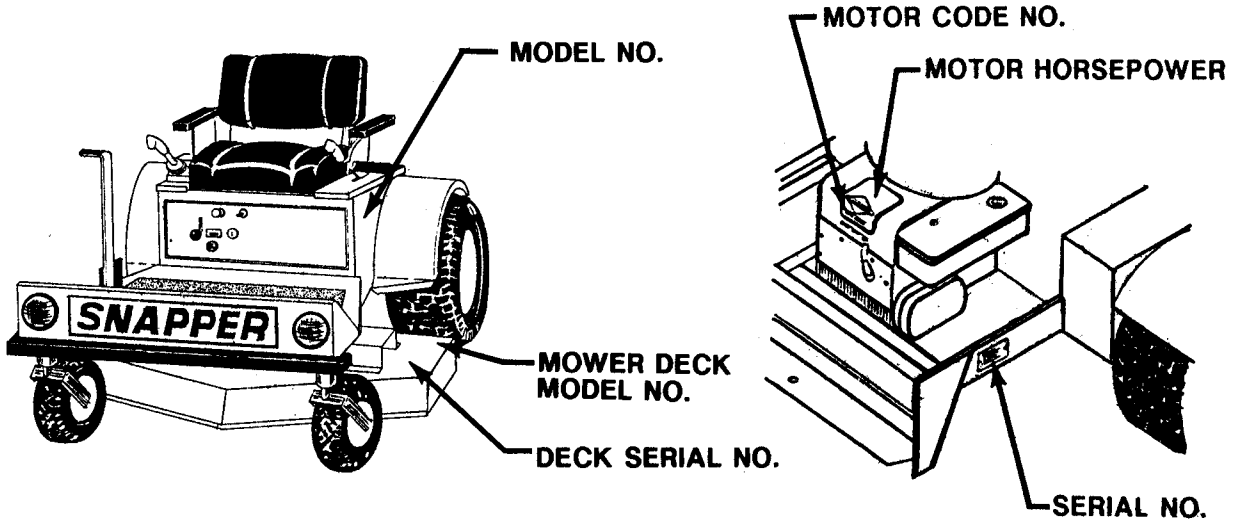

RECORD OF PURCHASE

DATE PURCHASED _____ MOWER MODEL _____

MOWER PURCHASED FROM _____
dealer name and phone number

MOWER FRAME SERIAL NUMBER _____

MOWING DECK SERIAL NUMBER _____

ENGINE CODE NUMBER _____