

Axion / 150Z Series

Initial setup

This Dealer Setup Instruction covers the following products:

Model. No.	Description
7800360	Simplicity Axion Model ZT18533, 18.5HP w/ 33" Mower
7800380	Simplicity Axion Model CZT18533, 18.5HP w/ 33" Mower (California Model)
7800269	Snapper 150Z Model SC18533, 18.5HP w/ 33" Mower
7800392	Snapper 150Z Model CSC18533, 18.5HP w/ 33" Mower (California Model)
7800374	Simplicity Axion Model ZT2142, 21HP w/ 42" Mower
7800381	Simplicity Axion Model CZT2142, 21HP w/ 42" Mower (California Model)
7800386	Snapper 150Z Model SC2142, 21HP w/ 42" Mower
7800393	Snapper 150Z Model CSC2142, 21HP w/ 42" Mower (California Model)
7800375	Simplicity Axion Model ZT2650, 26HP w/ 50" Mower
7800382	Simplicity Axion Model CZT2650, 26HP w/ 50" Mower (California Model)
7800387	Snapper 150Z Model SC2650, 26HP w/ 50" Mower
7800394	Snapper 150Z Model CSC2650, 26HP w/ 50" Mower (California Model)

TABLE OF CONTENTS:

SAFETY RULES	3
SETUP PROCEDURES	
Quick Setup List	6
Uncrating	7
Battery Activation & Installation	8
Installing the Seat	9
Setting up the Ground Speed Control Levers.....	11
Torque Mower Blade Hardware	12
Check Fluid levels	14
Fill and Check Engine Oil.....	14
Reduce and Check Tire Pressure	14
Lubrication	15
Burnish PTO Clutch	16
Check Rider Safety System	16

SAFETY RULES



Read these safety rules and follow them closely. Failure to obey these rules could result in loss of control of unit, severe personal injury or death to you, or bystanders, or damage to property or equipment.

This mowing deck is capable of amputating hands and feet and throwing objects.

The triangle in text signifies important cautions or warnings which must be followed.

GENERAL OPERATION

1. Read, understand, and follow all instructions in the manual and on the unit before starting.
2. Do not put hands or feet near rotating parts or under the machine. Keep clear of the discharge opening at all times.
3. Only allow responsible adults, who are familiar with the instructions, to operate the unit (local regulations can restrict operator age).
4. Clear the area of objects such as rocks, toys, wire, etc., which could be picked up and thrown by the blade(s).
5. Be sure the area is clear of other people before mowing. Stop the unit if anyone enters the area.
6. Never carry passengers.
7. Do not mow in reverse unless absolutely necessary. Always look down and behind before and while traveling in reverse.
8. Never direct discharge material toward anyone. Avoid discharging material against a wall or obstruction. Material may ricochet back toward the operator. Stop the blade(s) when crossing gravel surfaces.
9. Do not operate the machine without the entire grass catcher, discharge guard (deflector), or other safety devices in place and operational.
10. Slow down before turning.
11. Never leave a running unit unattended. Always disengage the blades (PTO), set parking brake, stop engine, and remove keys before dismounting.
12. Disengage blades (PTO) when not mowing. Shut off engine and wait for all parts to come to a complete stop before cleaning the machine, removing the grass catcher, or unclogging the discharge guard.
13. Operate the machine only in daylight or good artificial light.
14. Do not operate the unit while under the influence of alcohol or drugs.
15. Watch for traffic when operating near or crossing roadways.
16. Use extra care when loading or unloading the unit into a trailer or truck.
17. Always wear eye protection when operating this unit.
18. Data indicates that operators, age 60 years and above, are involved in a large percentage of power equipment-related injuries. These operators should evaluate their ability to operate the equipment safely enough to protect themselves and others from injury.
19. Follow the manufacturer's recommendations for wheel weights or counterweights.
20. Keep in mind the operator is responsible for accidents occurring to other people or property.
21. All drivers should seek and obtain professional and practical instruction.
22. Always wear substantial footwear and trousers. Never operate when barefoot or wearing sandals.
23. Before using, always visually check that the blades and blade hardware are present, intact, and secure. Replace worn or damaged parts.
24. Disengage attachments before: refueling, removing an attachment, making adjustments (unless the adjustment can be made from the operator's position).
25. When the machine is parked, stored, or left unattended, lower the cutting means unless a positive mechanical lock is used.
26. Before leaving the operator's position for any reason, engage the parking brake, disengage the blades (PTO), stop the engine, and remove the key.
27. To reduce fire hazard, keep the unit free of grass, leaves, & excess oil. Do not stop or park over dry leaves, grass, or combustible materials.
28. It is a violation of California Public Resource Code Section 4442 to use or operate the engine on or near any forest-covered, brush-covered, or grass-covered land unless the exhaust system is equipped with a spark arrester meeting any applicable local or state laws. Other states or federal areas may have similar laws.
29. OSHA regulations may require the use of hearing protection when exposed to sound levels greater than 85 dBA for an 8 hour time period.

CAUTION



This machine produces sound levels in excess of 85 dBA at the operator's ear and can cause hearing loss through extended periods of exposure.

Wear hearing protection when operating this machine.

TRANSPORTING AND STORAGE

1. When transporting the unit on an open trailer, make sure it is facing forward, in the direction of travel. If the unit is facing backwards, wind lift could damage the unit.
2. Always observe safe refueling and fuel handling practices when refueling the unit after transportation or storage.
3. Never store the unit (with fuel) in an enclosed poorly ventilated structure. Fuel vapors can travel to an ignition source (such as a furnace, water heater, etc.) and cause an explosion. Fuel vapor is also toxic to humans and animals.
4. Never store the unit or fuel container inside where there is an open flame or pilot light, such as near a water heater. Allow unit to cool before storing.

SLOPE OPERATION

Slopes are a major factor related to loss-of-control and tip-over accidents, which can result in severe injury or death. Operation on all slopes requires extra caution. If you cannot back up the slope or if you feel uneasy on it, do not operate on it.

Control of a walk-behind or ride-on machine sliding on a slope will not be regained by the application of the brake. The main reasons for loss of control are: insufficient tire grip on the ground, speed too fast, inadequate braking, the type of machine is unsuitable for its task, lack of awareness of the ground conditions, incorrect hitching and load distribution.

1. Mow up and down the face of slopes, not across.
2. Watch for holes, ruts, or bumps. Uneven terrain could overturn the unit. Tall grass can hide obstacles.
3. Choose a slow speed so that you will not have to stop or change speeds while on the slope.
4. Do not mow on wet grass. Tires may lose traction.
5. Avoid starting, stopping, or turning on a slope. If tires lose traction (i.e. machine stops forward motion on a slope), disengage the blade(s) (PTO) and drive slowly off the slope.
6. Keep all movement on slopes slow and gradual. Do not make sudden changes in speed or direction, which could cause the machine to rollover.
7. Use extra care while operating machines with grass catchers or other attachments; they can affect the stability of the unit. Do not use on steep slopes.
8. Do not try to stabilize the machine by putting your foot on the ground (ride-on units).
9. Do not mow near drop-offs, ditches, or embankments. The mower could suddenly turn over if a wheel is over the edge of a cliff or ditch, or if an edge caves in.
10. Do not use grass catchers on steep slopes.
11. Do not mow slopes if you cannot back up them.
12. See your authorized dealer/retailer for recommendations of wheel weights or counterweights to improve stability.
13. Remove obstacles such as rocks, tree limbs, etc.
14. Use slow speed. Tires may lose traction on slopes even through the brakes are functioning properly.
15. Do not turn on slopes unless necessary, and then, turn slowly and gradually uphill, if possible. Never mow down slopes.

TOWED EQUIPMENT (RIDE-ON UNITS)

1. Tow only with a machine that has a hitch designed for towing. Do not attach towed equipment except at the hitch point.
2. Follow the manufacturer's recommendations for weight limit for towed equipment and towing on slopes. See attaching a trailer under OPERATION.
3. Never allow children or others in or on towed equipment.
4. On slopes, the weight of the towed equipment may cause loss of traction and loss of control.
5. Travel slowly and allow extra distance to stop.
6. Do not shift to neutral and coast down hill.

WARNING

Never operate on slopes greater than 17.6 percent (10°) which is a rise of 3-1/2 feet (106 cm) vertically in 20 feet (607 cm) horizontally.

Select slow ground speed before driving onto slope. Use extra caution when operating on slopes with rear-mounted grass catchers.

Mow up and down the face of slopes, not across. Use caution when changing directions and **DO NOT START OR STOP ON SLOPE.**

CHILDREN

Tragic accidents can occur if the operator is not alert to the presence of children. Children are often attracted to the unit and the mowing activity. Never assume that children will remain where you last saw them.

1. Keep children out of the mowing area and under the watchful care of another responsible adult.
2. Be alert and turn unit off if children enter the area.
3. Before and during reverse operation, look behind and down for small children.
4. Never carry children, even with the blade(s) off. They may fall off and be seriously injured or interfere with safe unit operation. Children who have been given rides in the past may suddenly appear in the mowing area for another ride and be run over or backed over by the machine.
5. Never allow children to operate the unit.
6. Use extra care when approaching blind corners, shrubs, trees, or other objects that may obscure vision.

EMISSIONS

1. Engine exhaust from this product contains chemicals known, in certain quantities, to cause cancer, birth defects, or other reproductive harm.
2. Look for the relevant Emissions Durability Period and Air Index information on the engine emissions label.

IGNITION SYSTEM

1. This spark ignition system complies with Canadian ICES-002.

SERVICE AND MAINTENANCE

Safe Handling of Gasoline

1. Extinguish all cigarettes, cigars, pipes, and other sources of ignition.
2. Use only approved gasoline containers.
3. Never remove the gas cap or add fuel with the engine running. Allow the engine to cool before refueling.
4. Never fuel the machine indoors.
5. Never store the machine or fuel container where there is an open flame, spark, or pilot light such as near a water heater or other appliance.
6. Never fill containers inside a vehicle or on a truck bed with a plastic bed liner. Always place containers on the ground away from your vehicle before filling.
7. Remove gas-powered equipment from the truck or trailer and refuel it on the ground. If this is not possible, then refuel such equipment on a trailer with a portable container, rather than from a gasoline dispenser nozzle.
8. Keep nozzle in contact with the rim of the fuel tank or container opening at all times until fueling is complete. Do not use a nozzle lock-open device.
9. If fuel is spilled on clothing, change clothing immediately.
10. Never over-fill the fuel tank. Replace gas cap and tighten securely.
11. Use extra care in handling gasoline and other fuels. They are flammable and vapors are explosive.
12. If fuel is spilled, do not attempt to start the engine but move the machine away from the area of spillage and avoid creating any source of ignition until fuel vapors have dissipated.
13. Replace all fuel tank caps and fuel container caps securely.

Service & Maintenance

1. Never run the unit in an enclosed area where carbon monoxide fumes may collect.
2. Keep nuts and bolts, especially blade attachment bolts, tight and keep equipment in good condition.
3. Never tamper with safety devices. Check their proper operation regularly and make necessary repairs if they are not functioning properly.
4. Keep unit free of grass, leaves, or other debris build-up. Clean up oil or fuel spillage and remove any fuel-soaked debris. Allow machine to cool before storage.
5. If you strike an object, stop and inspect the machine. Repair, if necessary, before restarting.
6. Never make adjustments or repairs with the engine running.
7. Check grass catcher components and the discharge guard frequently and replace with manufacturer's recommended parts, when necessary.
8. Mower blades are sharp. Wrap the blade or wear gloves, and use extra caution when servicing them.
9. Check brake operation frequently. Adjust and service as required.
10. Maintain or replace safety and instructions labels, as necessary.
11. Do not remove the fuel filter when the engine is hot as spilled gasoline may ignite. Do not spread fuel line clamps further than necessary. Ensure clamps grip hoses firmly over the filter after installation.
12. Do not use gasoline containing METHANOL, gasohol containing more than 10% ETHANOL, gasoline additives, or white gas because engine/fuel system damage could result.
13. If the fuel tank must be drained, it should be drained outdoors.
14. Replace faulty silencers/mufflers.
15. Maintain or replace safety and instruction labels as necessary.
16. Use only authorized replacement parts when making repairs.
17. Always comply with factory specifications on all settings and adjustments.
18. Only authorized service locations should be utilized for major service and repair requirements.
19. Never attempt to make major repairs on this unit unless you have been properly trained. Improper service procedures can result in hazardous operation, equipment damage and voiding of manufacturer's warranty.
20. On multiple blade mowers, take care as rotating one blade can cause other blades to rotate.
21. Do not change engine governor settings or over-speed the engine. Operating the engine at excessive speed can increase the hazard of personal injury.
22. Disengage drive attachments, stop the engine, remove the key, and disconnect the spark plug wire(s) before: clearing attachment blockages and chutes, performing service work, striking an object, or if the unit vibrates abnormally. After striking an object, inspect the machine for damage and make repairs before restarting and operating the equipment.
23. Never place hands near the moving parts, such as a hydro pump cooling fan, when the tractor is running. (Hydro pump cooling fans are typically located on top of the transaxle).
24. Units with hydraulic pumps, hoses, or motors: **WARNING:** Hydraulic fluid escaping under pressure may have sufficient force to penetrate skin and cause serious injury. If foreign fluid is injected into the skin it must be surgically removed within a few hours by a doctor familiar with this form of injury or gangrene may result. Keep body and hands away from pin holes or nozzles that eject hydraulic fluid under high pressure. Use paper or cardboard, and not hands, to search for leaks. Make sure all hydraulic fluid connections are tight and all hydraulic hoses and lines are in good condition before applying pressure to the system. If leaks occur, have the unit serviced immediately by your authorized service center.
25. **WARNING:** Stored energy device. Improper release of springs can result in serious personal injury. Springs should be removed by an authorized technician.



Quick Setup List

Page	Setup Procedure	Steps to Perform
7	Uncrating	<ul style="list-style-type: none"> <input type="checkbox"/> Remove crate & banding. <input type="checkbox"/> Place transmissions in ROLL RELEASE position & roll off skid.
8	Battery Activation & Installation	<ul style="list-style-type: none"> <input type="checkbox"/> Charge the battery (<i>Note: proceed with other setup steps while battery is charging</i>). <input type="checkbox"/> Install & secure battery.
9-13	Mower Assembly	<ul style="list-style-type: none"> <input type="checkbox"/> Install the seat. <input type="checkbox"/> Install the seat safety switch. <input type="checkbox"/> Set up the ground speed control levers. <input type="checkbox"/> Torque the mower blade hardware.
14	Check Fluid Levels	<ul style="list-style-type: none"> <input type="checkbox"/> Fill & check Engine oil level. <input type="checkbox"/> Reduce & check tire pressures (<i>Front tires 18-20 psi, rear tires 10-12 psi</i>).
15	Lubrication	<ul style="list-style-type: none"> <input type="checkbox"/> Lubricate all grease & oil points.
16	Burnish PTO Clutch	<ul style="list-style-type: none"> <input type="checkbox"/> Burnish PTO clutch (<i>run for 15 seconds, repeat 10 times</i>).
16	SAFETY CHECKS	<ul style="list-style-type: none"> <input type="checkbox"/> Perform SAFETY INTERLOCK SYSTEM CHECK. <input type="checkbox"/> Perform MOWER BLADE STOPPING CHECK. (<i>Blade must stop within 5 seconds!</i>)

Setup



Uncrating

1. Using a reciprocating utility saw or equivalent, cut crate away from bottom skid. Remove crate. Remove plastic wrap.
2. Cut any banding securing the unit.



IMPORTANT NOTE

When cutting crate from bottom skid, use caution around tires and mower rollers.

3. Locate the transmission release levers (C, Figure 1) at the rear of the unit.
4. Pull **both** levers back and down to release the transmissions (position B, Figure 1).
5. Pull the ground speed control levers in to their DRIVE positions, and disengage the parking brake.
The rider can now be pushed by hand.
6. After moving the rider, set the ground speed control levers to START/PARK, engage the parking brake, and push **both** transmission release levers forward to re-engage the transmissions (position A, Figure 1).



DO NOT TOW RIDER

Towing the unit will cause transmission damage. Do not use another vehicle to push or pull this unit. Do not use this unit to push or pull another vehicle or object.

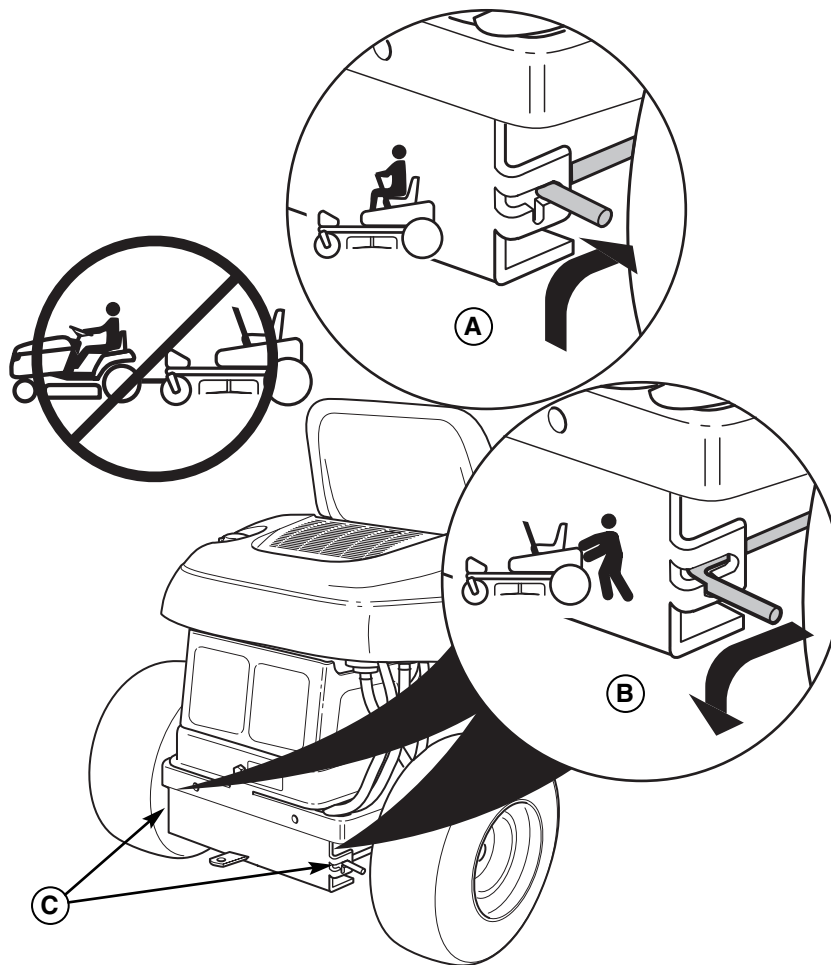

Figure 1. Pushing the rider



Battery Activation & Installation

Charge Battery

1. Tip the seat forward to access the battery.
2. Remove the battery from the battery compartment, and place the battery on a level, non-concrete surface.

Note: When removing the battery cables from the battery, always remove the negative (-) cable first.

3. To charge the battery, follow the instructions provided by the battery charger manufacturer as well as all warnings included in the safety rules section of this document. Charge the battery at 6-10 amps for 1 hour. Do not charge at a rate higher than 10 amps. See Figure 2.

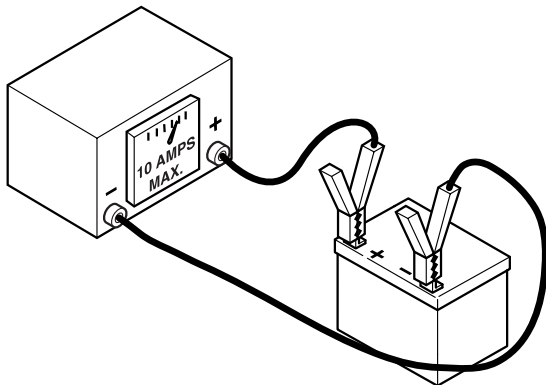

Figure 2. Charging the battery

WARNING



Corrosion hazard.

Batteries contain acid. Always keep the battery upright and do not spill the electrolyte. Avoid contact with skin and eyes.



Explosion hazard.

Changing the battery produces explosive hydrogen gas. Only charge the battery in a well ventilated area, away from any ignition source such as a water heater, electric motor, or a lit cigarette.



Wear Protective Equipment

Always wear gloves and safety glasses when handling the battery and battery cables.

Install Battery

1. Install and secure the battery in the battery compartment (Figure 3).
2. Connect the red positive battery cable (A, Figure 4) to the positive battery terminal, then cover the positive battery terminal with the terminal cover.
3. Connect the black negative battery cable (B) to the negative battery terminal.

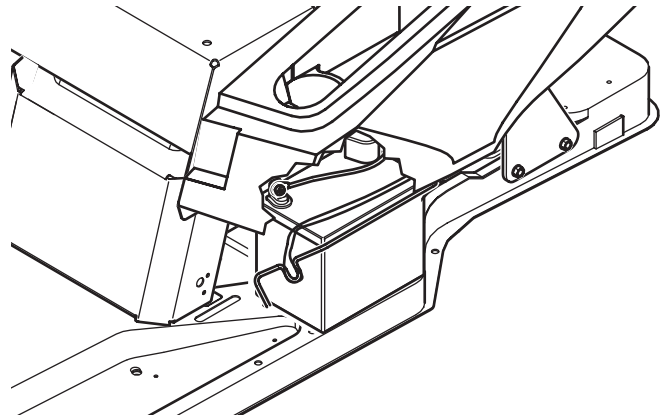

Figure 3. Installing the battery

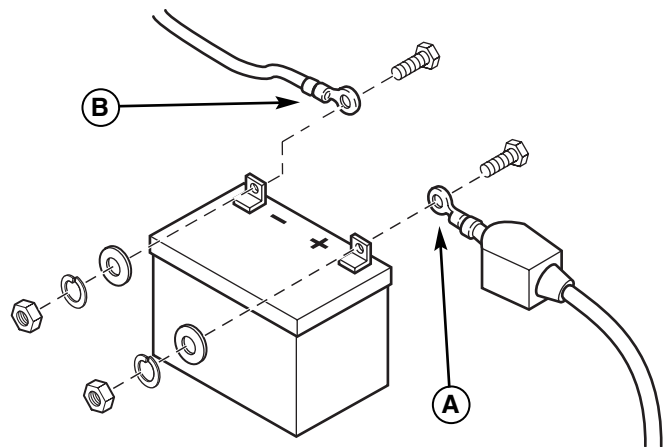

Figure 4. Installing the battery cables

Setup



Installing the Seat

1. Raise the seat base.
2. Align the holes in the seat bottom with the holes in the seat base.
3. Secure the seat to the seat base with four 5/16-18 x 3/4" bolts. Torque to 14-19 ft. lbs. (19-25 N.m.) See Figure 5.

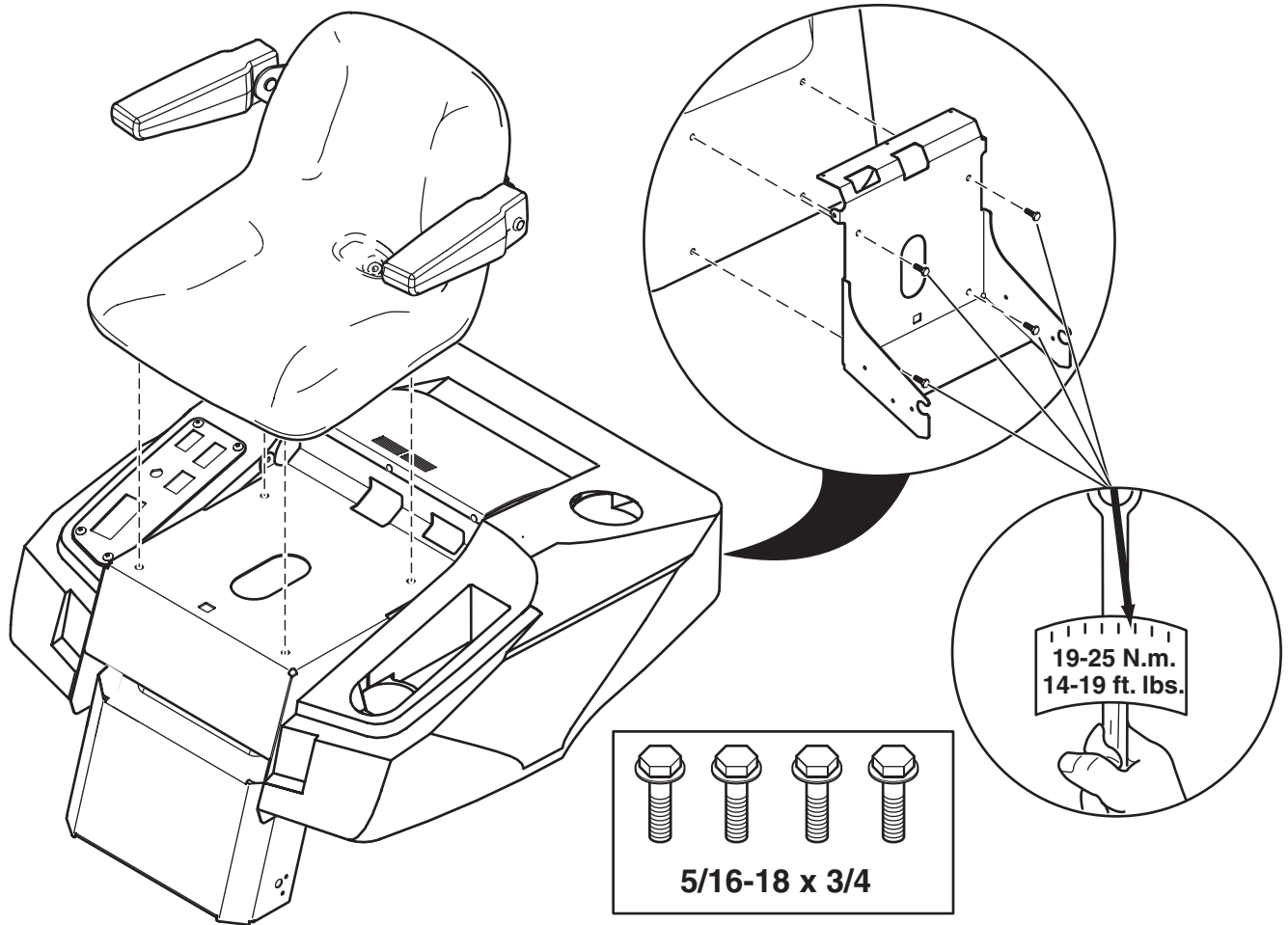

Figure 5. Installing the seat

Setup

Installing the Seat Safety Switch

1. Squeeze the side clips of the safety switch (A, Figure 6), and insert the switch into the slot (B) in the seat bottom. Be sure to slide the switch fully forward.
2. Connect the harness terminal housing (C) to the seat switch.
3. Loop the wire tie (D) around both the switch body and the terminal housing.

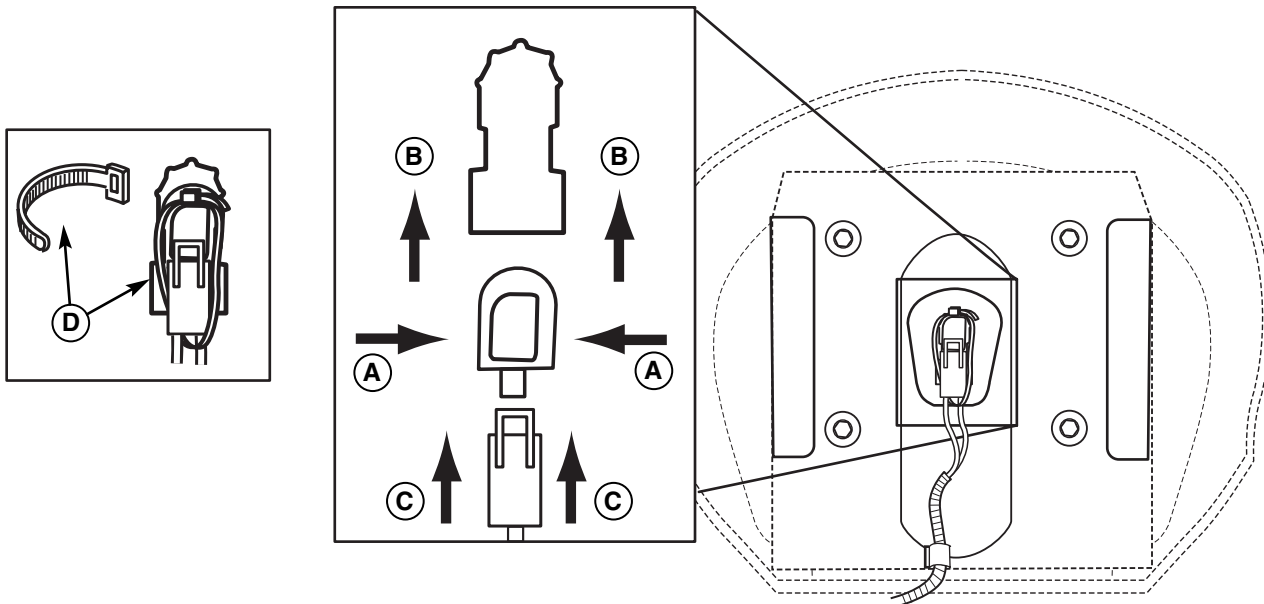

Figure 6. Installing the seat safety switch

Setup



Setting Up the Ground Speed Control Levers

1. Loosen (do not remove) the hardware securing the ground speed control levers to the lever bases.
2. Raise the levers, aligning the upper hole in each lever with the upper slotted hole in the lever base.

3. Install the noted hardware as shown in Figure 7. Tighten all hardware. Torque to 15-17 ft. lbs. (20-23 N.m.).

Note: Ground speed control levers must be adjusted prior to use. Refer to the Section 'Ground Speed Control Lever Adjustment' in the Operator's Manual.

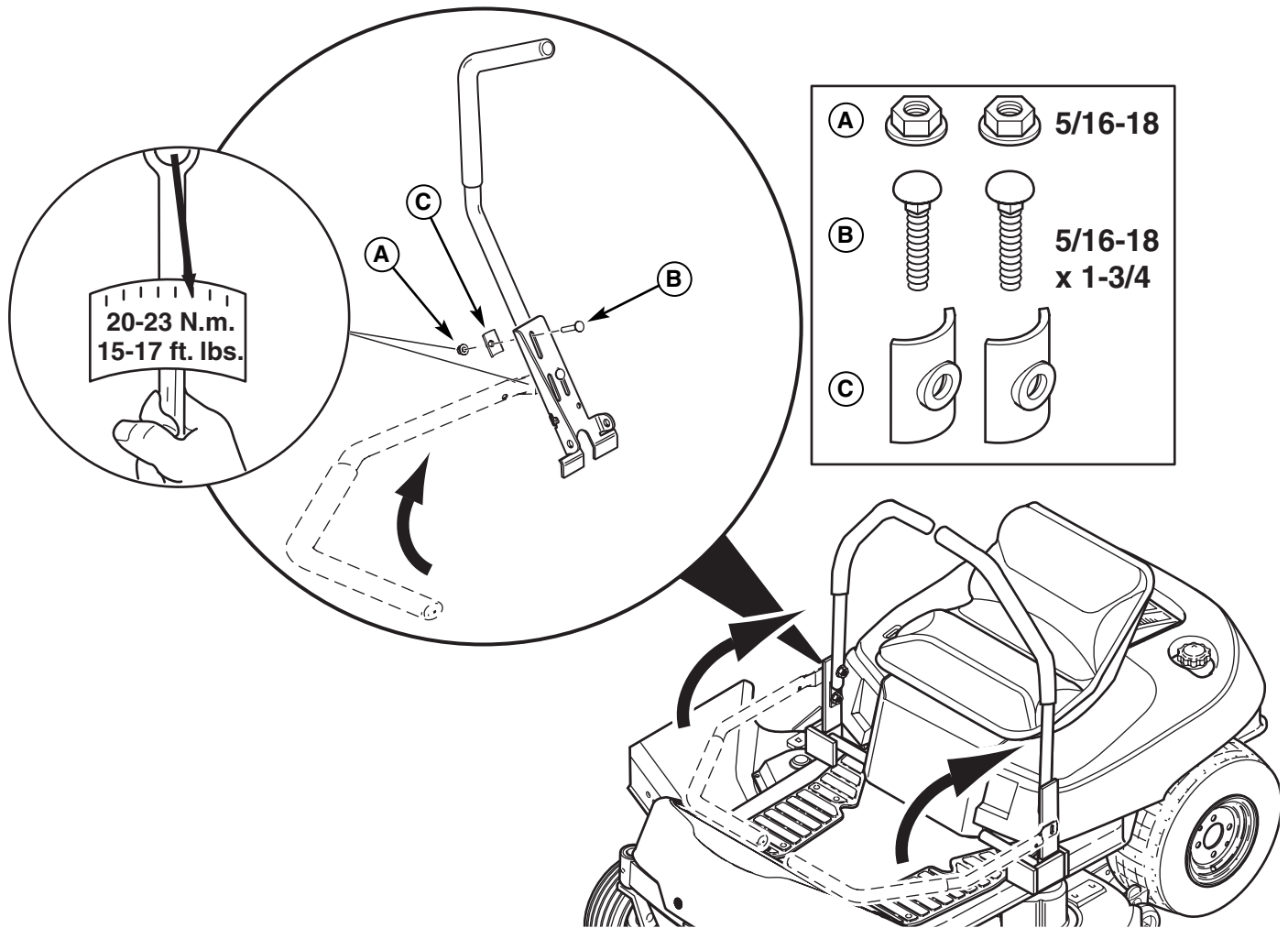

Figure 7. Setting up the ground speed levers

Setup



Torque Mower Blade Hardware

1. Check to see that the blade and hardware are installed according to the diagram shown (A, Figures 8-10).
2. Torque the blade hardware to the noted torque (B):

Note: Use a wooden block to prevent blade rotation.

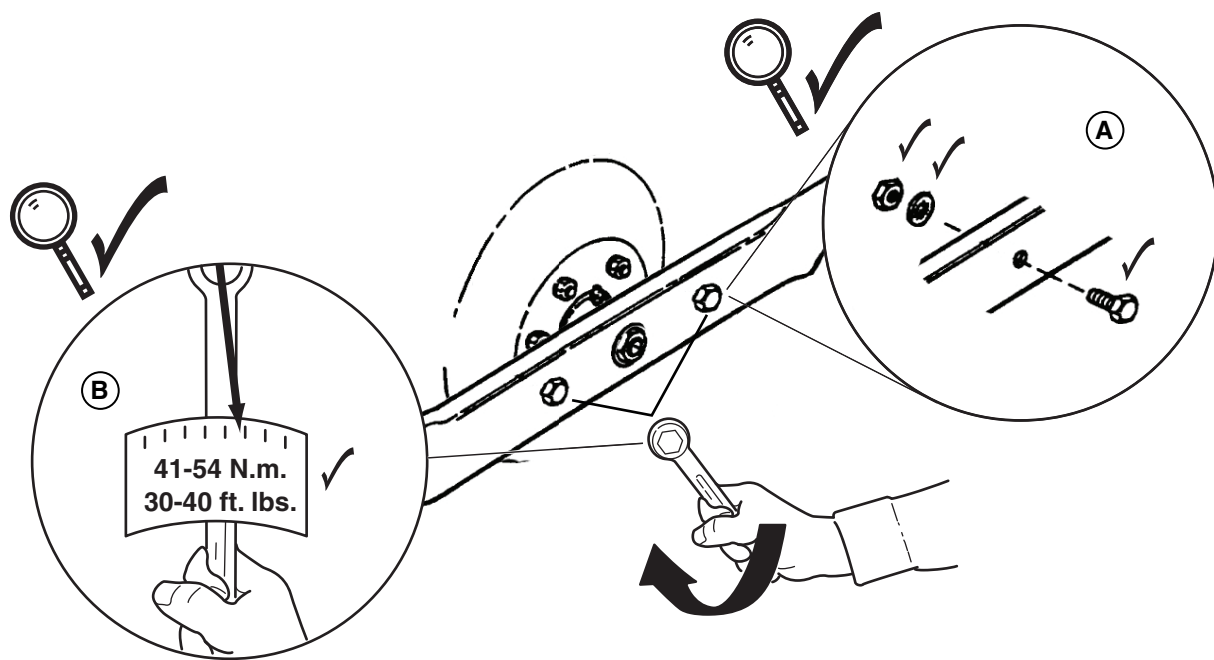

Figure 8. Torquing the mower blade hardware (33" Deck)

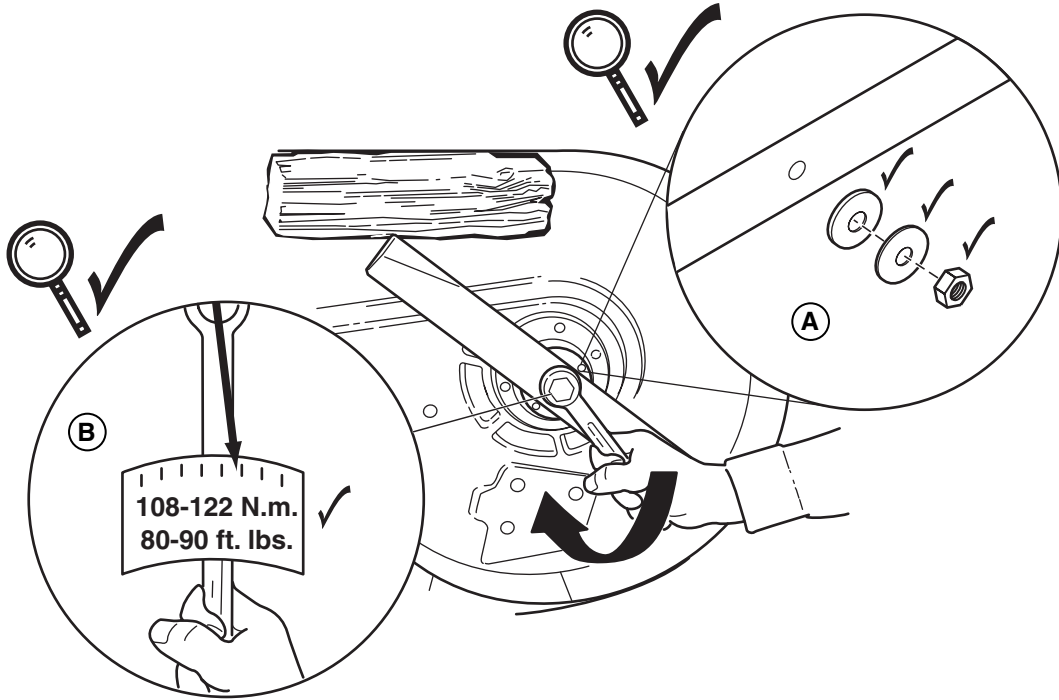

Figure 9. Torquing the mower blade hardware (42" Deck)

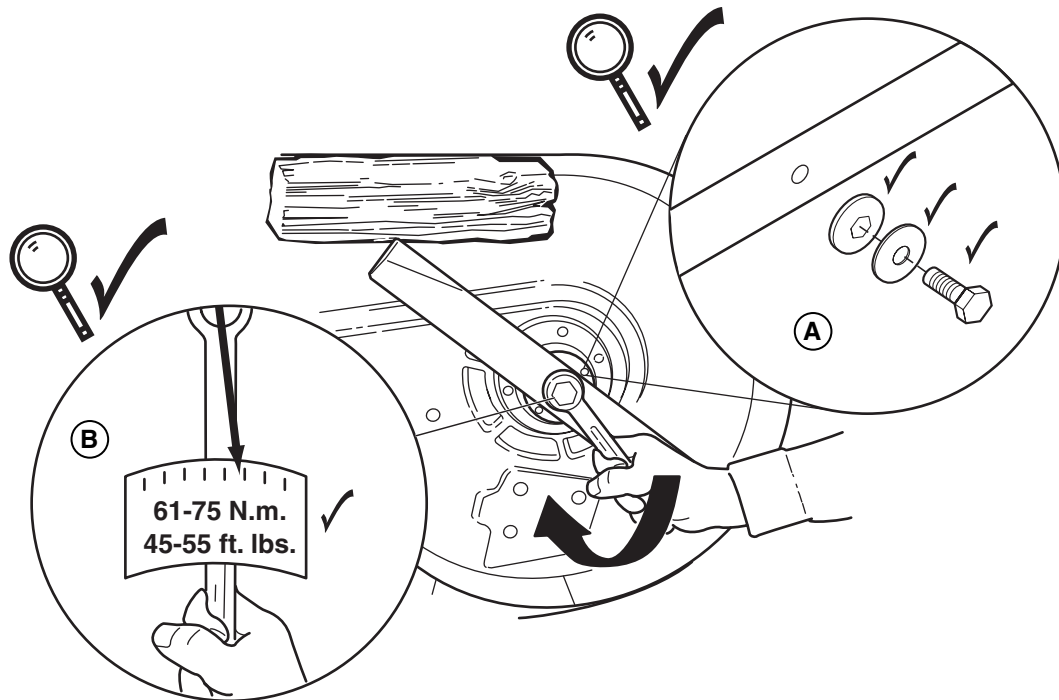



Figure 10. Torquing the mower blade hardware (50" Deck)

Setup

Check Fluid Levels
Fill & Check Engine Oil

Removing the rear cover to gain access to the engine, use the dipstick (Figure 11) to check the engine oil level. If necessary add engine oil. Check engine manufacturer's owner's manual for oil recommendations.

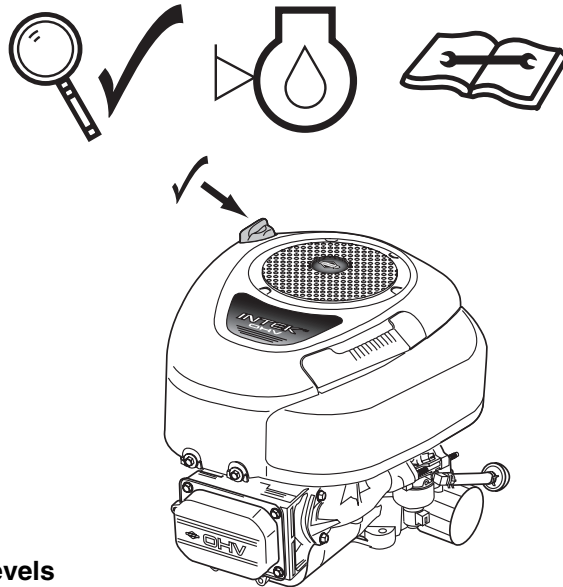
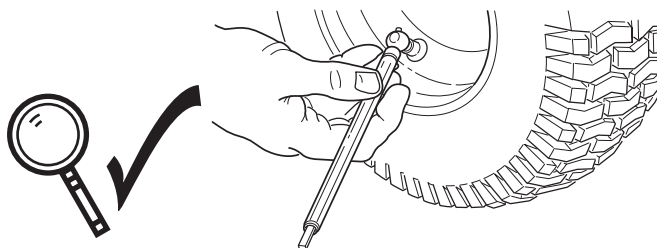

Figure 11. Checking the fluid levels

Setup

Reduce & Check Tire Pressures

The tires are over-inflated for shipping purposes. Inflate to the pressures shown (Figure 12). Note that these pressures may differ slightly from the "Max Inflation" stamped on the side-wall of the tires. The pressures shown provide proper traction, improve cut quality, and extend tire life.



Size	PSI	bar
Front	18-20	1,24-1,38
Rear	10-12	,69-,83

Figure 12. Checking the tire pressure

Setup



Lubrication

Lubricate the unit at the following lubrication points as well as those shown in Figures 13-15.

Grease:

- front caster wheel axles
- front caster spindle bosses
- front axle center pivot
- mower deck arbors (blade spindles)*
- mower deck idler arm

Oil:

- ground speed control lever pivot points
- discharge chute hinge
- deck lift pivot points

Generally, all moving metal parts should be oiled where contact is made with other parts. Keep oil and grease off belts and pulleys. Remember to wipe fittings and surfaces clean both before and after lubrication. Use grease fittings when present. Disassemble parts to apply grease to moving parts when grease fittings are not installed.

Not all greases are compatible. Use automotive-type lithium grease.

* Some deck arbors have grease fittings above the mower deck, while others have grease fittings below the deck.

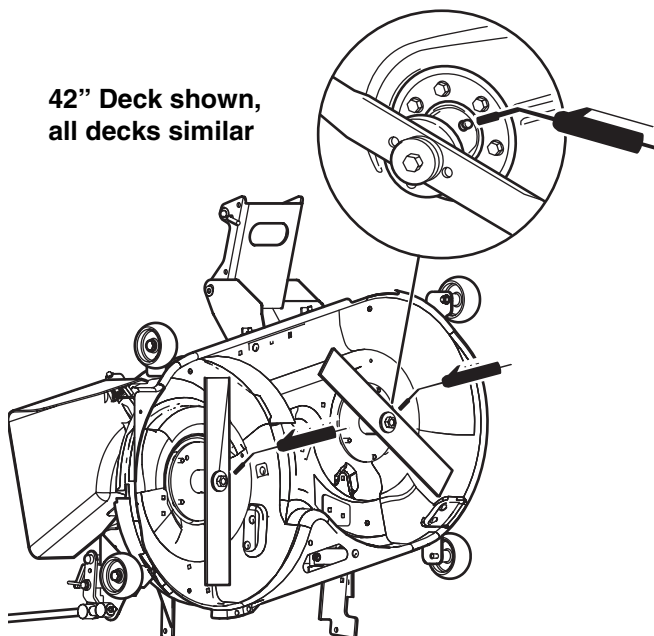

Figure 13. Lubrication (deck)

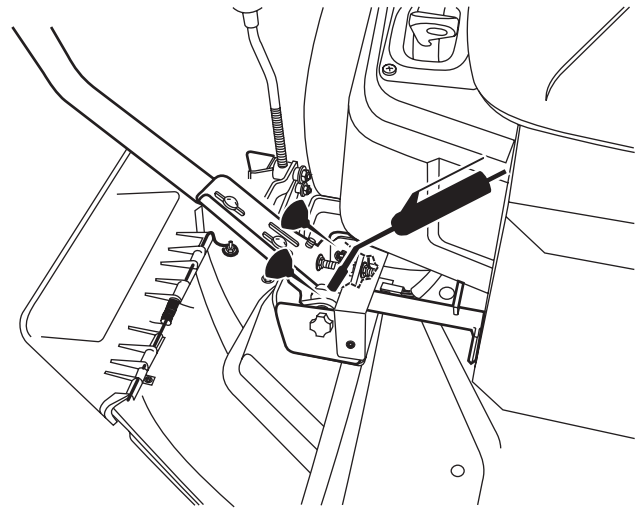

Figure 14. Lubrication (ground speed control levers)

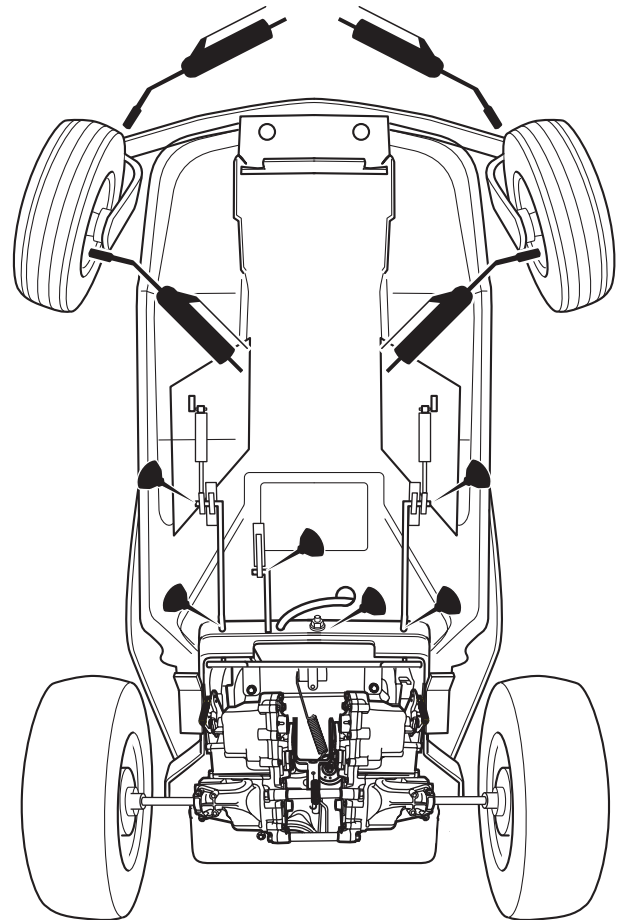

Figure 15. Lubrication (chassis and wheels)

Setup



Burnish PTO Clutch

1. Engage the parking brake, start the tractor, and set engine speed to full throttle.
2. Engage the PTO switch for fifteen seconds, then disengage it and wait for the mower blades to stop.
3. Repeat step 2 ten times taking note of mower blade stopping time. (Stopping time must be five seconds or less.) If the unit fails this test, perform the PTO clutch adjustment found in the "Regular Maintenance" section or replace the clutch.



CHECK RIDER SAFETY SYSTEM

Service Interval: Every 100 hours, every spring/fall, and after storage of 30 days or longer.

This unit is equipped with safety interlock switches. These safety systems are present for your safety. Do not attempt to bypass safety switches, and never tamper with safety devices. Check their operation regularly.

Operational SAFETY Checks

TEST 1 — ENGINE SHOULD NOT CRANK IF:

- Mower blades switch is ON, OR
- Ground speed control levers are not in their START/PARK positions, OR
- Parking brake lever is in DISENGAGE position.

TEST 2 — ENGINE SHOULD CRANK IF:

- Mower blade switch is OFF, AND
- Ground speed control levers are in their START/PARK positions, AND
- Parking brake lever is in ENGAGE position.

TEST 3 — ENGINE SHOULD SHUT OFF IF:

- Operator rises off seat with the mower blade switch ON, OR
- Operator rises off seat with the ground speed levers in DRIVE positions, OR
- Operator rises off seat with the parking brake in DISENGAGE position, OR
- Operator moves the left and/or right ground speed control lever out of its START/PARK position with the parking brake lever in ENGAGE position.

TEST 4 — BLADE BRAKE CHECK

The mower blades and mower drive belt should come to a complete stop within five seconds after the mower blade switch is turned OFF. If mower drive belt does not stop within five seconds, contact your local authorized dealer.

NOTE: Once the engine has stopped, the mower blade switch must be turned OFF, the ground speed control levers must be locked in their START/PARK positions, and the parking brake lever must be in the ENGAGE position in order to start the engine.



WARNING

If the unit does not pass a safety test, do not operate it. See your local authorized dealer. Under no circumstance should you attempt to defeat the purpose of the safety interlock system.