

Grizzly *Industrial, Inc.*®

MODEL G5789/G5790
13-PIECE 3/4"
IMPACT WRENCH KIT
INSTRUCTION MANUAL



COPYRIGHT © MAY, 2008 BY GRIZZLY INDUSTRIAL, INC.
**WARNING: NO PORTION OF THIS MANUAL MAY BE REPRODUCED IN ANY SHAPE
OR FORM WITHOUT THE WRITTEN APPROVAL OF GRIZZLY INDUSTRIAL, INC.**
#JM10716 PRINTED IN TAIWAN

SAFETY

WARNING

For Your Own Safety Read Instruction Manual Before Operating This Equipment

The purpose of safety symbols is to attract your attention to possible hazardous conditions. This manual uses a series of symbols and signal words which are intended to convey the level of importance of the safety messages. The progression of symbols is described below. Remember that safety messages by themselves do not eliminate danger and are not a substitute for proper accident prevention measures.



Indicates an imminently hazardous situation which, if not avoided, **WILL** result in death or serious injury.



Indicates a potentially hazardous situation which, if not avoided, **COULD** result in death or serious injury.



Indicates a potentially hazardous situation which, if not avoided, **MAY** result in minor or moderate injury. It may also be used to alert against unsafe practices.

NOTICE

This symbol is used to alert the user to useful information about proper operation of the equipment.

WARNING

Safety Instructions For Pneumatic Tools

- 1. READ THIS MANUAL.** This tool may cause personal injury if used incorrectly. This manual contains proper safety and operating instructions that must be followed to reduce this risk.
- 2. WEAR EYE PROTECTION.** This tool may throw small fragments during operation, which may cause serious eye injury. Always wear ANSI approved safety glasses or face shield to reduce your risk from this hazard.
- 3. WEAR A RESPIRATOR.** This tool may produce fine dust during operation, which can cause respiratory injury if inhaled. Always wear a respirator NIOSH approved for the type of material being processed.
- 4. WEAR HEARING PROTECTION.** Operating this tool for prolonged time periods may damage your hearing. Your risk depends on length and frequency of use. To reduce your risk of this hazard, wear hearing protection.
- 5. MAINTAIN SAFETY GUARDS.** Your tool may be equipped with safety guards or other structural components designed to reduce the risk of injury during operation. Never modify or operate this tool with any guards or components removed or damaged.
- 6. KEEP CHILDREN AWAY.** Prevent children from injury by keeping them away from this tool. Disconnect and lock the tool away when not in use.

7. **AVOID ENTANGLEMENTS.** Do not wear loose clothing, gloves, neckties, rings, bracelets, or other jewelry, which may get caught in moving parts, when operating this tool. Wear a protective hair covering to contain long hair.
8. **USE CORRECT AIR PRESSURE.** Exceeding the maximum PSI rating of this tool may cause unpredictable operation or bursting.
9. **DISCONNECT AIR PRESSURE** before servicing, changing accessories, or moving to another location. Never leave this tool unattended when connected to air.
10. **SECURE TOOLING.** Always verify tooling is secure before operation.
11. **SHARP SURFACES.** DO NOT place hands near the tooling surfaces when in operation.
12. **REMOVE ADJUSTING KEYS AND WRENCHES AFTER USE.** These tools become dangerous projectiles if left on the tool when it is started.
13. **AVOID FLAMMABLES.** Do not use this tool around any flammables that may be ignited by sparks.
14. **SECURE WORK.** Use clamps or a vise to hold work when practical. It is safer than using your hand and frees both hands to operate tool.
15. **MAINTAIN TOOLS WITH CARE.** Keep tools lubricated and clean for best and safest performance. Follow instructions for lubricating and changing accessories.
16. **DO NOT FORCE TOOL.** It will do the job better and safer at the rate for which it was designed.
17. **CHECK FOR DAMAGED PARTS BEFORE USING.** Check for binding and alignment of parts, broken parts, part mounting, loose bolts, and any other conditions that may affect operation. Repair or replace damaged parts before operating.
18. **USE GOOD LIGHTING.** Keep work area well lighted. Dark work areas increase risk of accidental injury.
19. **AVOID UNINTENTIONAL OPERATION.** Always disconnect air when not in use, and do not carry tool with hand on trigger.
20. **USE THE RECOMMENDED ACCESSORIES.** Consult owner's manual for recommended accessories. Using improper accessories may increase the risk of injury.
21. **NEVER ALLOW UNTRAINED USERS TO USE THIS TOOL WHILE UNSUPERVISED.**
22. **IF YOU ARE UNSURE OF THE INTENDED OPERATION, STOP USING TOOL.** Seek formal training or research books or magazines that specialize in pneumatic tools.
23. **BE AWARE OF HOSE LOCATION.** Hoses can easily become a tripping hazard when laid across the floor in a disorganized fashion.
24. **DO NOT USE UNDER THE INFLUENCE OF DRUGS OR ALCOHOL, OR WHEN TIRED.**

CAUTION

No list of safety guidelines is complete, because every work environment is different. Always consider safety first and use common sense. Failure to use this tool with caution and respect could result in serious personal injury.

Inventory



Figure 1. Model G5789/G5790 inventory.

OPERATIONS

⚠️ WARNING

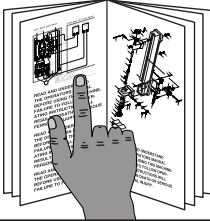

Read the manual before operation. Become familiar with this tool, its safety instructions, and its operation before beginning any work. Serious personal injury may result if safety or operational information is not understood or followed.

⚠️ WARNING

	<p>LUNG/EAR INJURY HAZARD! Wear protective equipment when using this tool.</p>
	<p>ACCIDENTAL START HAZARD! Disconnect before service or tool changes.</p>
	<p>AIR PRESSURE HAZARD! Never exceed 120 PSI.</p>
	<p>EYE INJURY HAZARD! Wear protective equipment when using these tools.</p>

G5789 Specifications

Drive Size 3/4"
 No-Load Speed 4,500 RPM
 Maximum Torque 500 ft/lb
 Air Inlet Size 3/8" or 1/4" NPT
 Air Consumption 7 CFM
 Operating Pressure 90 PSI
 Maximum Operating Pressure 120 PSI
 Weight 9.9 lbs

G5790 Specifications

Drive Size 3/4"
 No-Load Speed 4,500 RPM
 Maximum Torque 500 ft/lb
 Air Inlet Size 3/8" or 1/4" NPT
 Air Consumption 7 CFM
 Operating Pressure 90 PSI
 Maximum Operating Pressure 120 PSI
 Weight 9.9 lbs

Air Supply

The impact wrench requires 90 PSI to operate correctly. To improve air tool lifespan, use a filter/lubricator/regulator setup shown in **Figure 2**.

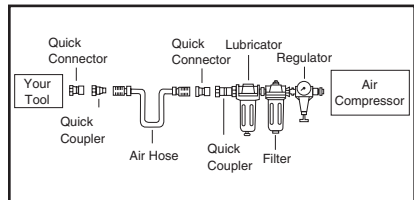

Figure 2. Installed filter lubricator regulator.

Otherwise, lubricate the impact wrench daily with a 2–6 drops of pneumatic tool oil directly into the tool's air inlet fitting, as shown in **Figure 3**, before and after each use and every 2 hours of continued use.

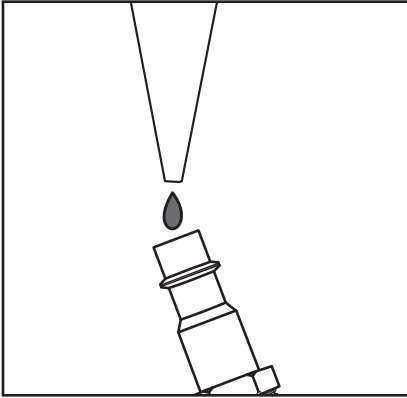

Figure 3. Manual oiling.

Impact Wrench

Your new $\frac{3}{4}$ " drive impact wrench (**Figure 3**) will generate up to 500 ft/lbs. of torque.

Only use thick-walled impact sockets with this air tool. The common thin-walled chrome sockets may explode if used as impact sockets, causing serious injury.

The impact wrench comes with a $\frac{3}{8}$ "– $\frac{1}{4}$ " NPT adapter. For maximum results, we recommend using a $\frac{3}{8}$ " air fitting and hose.

To change the torque setting, turn the torque setting knob from 0 to 9; 9 is the highest torque setting.

To change the direction of rotation, push the reverse valve toward the front of the gun for clockwise rotation and to the rear for counterclockwise rotation.

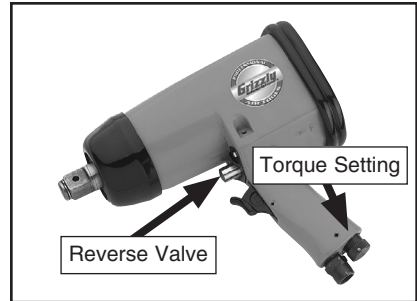

Figure 4. Impact wrench control locations.

Daily Maintenance

These procedures should be done after each use:

- Before putting the impact wrench away, put 2-6 drops of oil into the air supply fitting and momentarily operate the tool to distribute the oil inside.
- Wipe the tool exterior and sockets with a slightly oiled cloth. Your goal is to leave a light film of oil on the tool to prevent rust.

G5789 IMPACT WRENCH

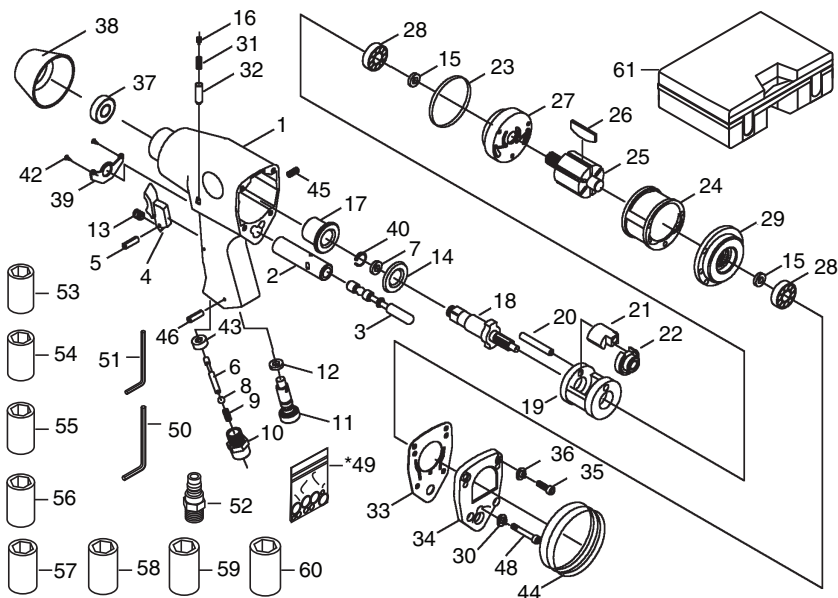

REF PART # DESCRIPTION

REF	PART #	DESCRIPTION
1	P8125001	HOUSING
2	P8125002	VALVE SLEEVE
3	P8125003	REVERSE VALVE
4	P8125004	TRIGGER
5	P8125005	ROLL PIN
6	P8125006	VALVE BUSHING
7	P8125007	O-RING
8	P8125008	STEEL BALL
9	P8125009	COMPRESSION SPRING
10	P8125010	AIR FITTING 3/8"-1/4" NPT
11	P8125011	AIR VALVE KNOB
12	P8125012	O-RING
13	P8125013	SET SCREW
14	P8125014	SPACER
15	P8125015	OIL SEAL
16	P8125016	PILOT SET SCREW
17	P8125017	ANVIL BUSHING
18	P8125018	ANVIL 3/4" DRIVE
19	P8125019	HAMMER CAGE
20	P8125020	HAMMER PIN
21	P8125021	HAMMER DOG
22	P8125022	DRIVE CAM
23	P8125023	O-RING
24	P8125024	CYLINDER
25	P8125025	ROTOR
26	P8125026	ROTOR BLADE
27	P8125027	FRONT PLATE
28	P8125028	BEARING
29	P8125029	REAR PLATE
30	P8125030	WASHER

REF PART # DESCRIPTION

REF	PART #	DESCRIPTION
31	P8125031	COMPRESSION SPRING
32	P8125032	PIN
33	P8125033	REAR GASKET
34	P8125034	REAR COVER
35	P8125035	CAP SCREW
36	P8125036	LOCK WASHER
37	P8125037	OIL SEAL
38	P8125038	FRONT RUBBER
39	P8125039	EXHAUST DEFLECTOR
40	P8125040	ANVIL COLLAR
42	P8125042	PHLP HD SCREW
43	P8125043	RUBBER BUSHING
44	P8125044	REAR RUBBER
45	P8125045	SET SCREW
46	P8125046	ROLL PIN
48	P8125048	SPECIAL CAP SCREW
*49	P8125049	O-RING KIT
50	PAW05M	HEX WRENCH 5MM
51	PAW04M	HEX WRENCH 4MM
52	P5789052	1/4" NPT AIR FITTING
53	P5789053	SOCKET 3/4 DRV X 26MM
54	P5789054	SOCKET 3/4 DRV X 27MM
55	P5789055	SOCKET 3/4 DRV X 29MM
56	P5789056	SOCKET 3/4 DRV X 30MM
57	P5789057	SOCKET 3/4 DRV X 32MM
58	P5789058	SOCKET 3/4 DRV X 35MM
59	P5789059	SOCKET 3/4 DRV X 36MM
60	P5789060	SOCKET 3/4 DRV X 38MM
61	P5789061	CARRYING CASE

* Not Included; for aftermarket purchase only

G5790 IMPACT WRENCH

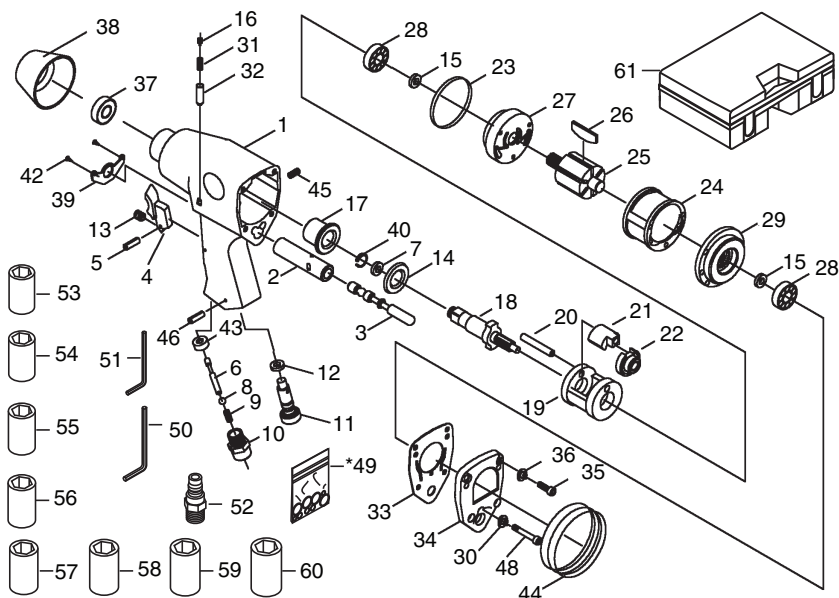

REF	PART #	DESCRIPTION
1	P8125001	HOUSING
2	P8125002	VALVE SLEEVE
3	P8125003	REVERSE VALVE
4	P8125004	TRIGGER
5	P8125005	ROLL PIN
6	P8125006	VALVE BUSHING
7	P8125007	O-RING
8	P8125008	STEEL BALL
9	P8125009	COMPRESSION SPRING
10	P8125010	AIR FITTING 3/8"-1/4" NPT
11	P8125011	AIR VALVE KNOB
12	P8125012	O-RING
13	P8125013	SET SCREW
14	P8125014	SPACER
15	P8125015	OIL SEAL
16	P8125016	PILOT SET SCREW
17	P8125017	ANVIL BUSHING
18	P8125018	ANVIL 3/4" DRIVE
19	P8125019	HAMMER CAGE
20	P8125020	HAMMER PIN
21	P8125021	HAMMER DOG
22	P8125022	DRIVE CAM
23	P8125023	O-RING
24	P8125024	CYLINDER
25	P8125025	ROTOR
26	P8125026	ROTOR BLADE
27	P8125027	FRONT PLATE
28	P8125028	BEARING
29	P8125029	REAR PLATE
30	P8125030	WASHER

REF	PART #	DESCRIPTION
31	P8125031	COMPRESSION SPRING
32	P8125032	PIN
33	P8125033	REAR GASKET
34	P8125034	REAR COVER
35	P8125035	CAP SCREW
36	P8125036	LOCK WASHER
37	P8125037	OIL SEAL
38	P8125038	FRONT RUBBER
39	P8125039	EXHAUST DEFLECTOR
40	P8125040	ANVIL COLLAR
42	P8125042	PHLP HD SCREW
43	P8125043	RUBBER BUSHING
44	P8125044	REAR RUBBER
45	P8125045	SET SCREW
46	P8125046	ROLL PIN
48	P8125048	SPECIAL CAP SCREW
*49	P8125049	O-RING KIT
50	PAW05M	HEX WRENCH 5MM
51	PAW04M	HEX WRENCH 4MM
52	P5789052	1/4" NPT AIR FITTING
53	P5790053	SOCKET 3/4 DRV X 1"
54	P5790054	SOCKET 3/4 DRV X 1-1/16"
55	P5790055	SOCKET 3/4 DRV X 1-1/8"
56	P5790056	SOCKET 3/4 DRV X 1-3/16"
57	P5790057	SOCKET 3/4 DRV X 1-1/4"
58	P5790058	SOCKET 3/4 DRV X 1-3/8"
59	P5790059	SOCKET 3/4 DRV X 1-7/16"
60	P5790060	SOCKET 3/4 DRV X 1-1/2"
60	P5790061	CARRYING CASE

* Not Included; for aftermarket purchase only

Model G5789/G5790 13-Piece 3/4" Impact Wrench Kit