

SNAPPER SET-UP INSTRUCTION for LOAD CARRIER KIT P.N. 6-0197 for SNAPPER RIDING MOWERS

In addition to providing a handy tote box on the front end of your SNAPPER Rider for general chores, the carrier is a must especially if the Rider is equipped with a rear mounted grass catcher and it is to be operated on slopes in excess of 10 degrees (17% grade). Under these conditions, the carrier should be weighted down with 50 pounds of material to counter-balance the weight of the grass as the catcher is filled and keep the front wheels firmly on the ground to prevent loss of steering control and stability.

PRE-ASSEMBLY (NEW KIT)

The following pre-assembly steps are initially required to prepare the kit for installation. Refer to the illustration below for identification of the components described.

STEP 1: Assemble the braces on the inside of the side rails and secure each with one 3/8-16 x 1" capscREW, 3/8 SAE flat washer and 3/8-16 hex locknut in sequence as shown below.

STEP 2: Position the spacer between the side rails, insert the 10" long bolt through the holes in the rails and spacer, then install a 3/8 SAE flat washer and 3/8-16 hex locknut on the threaded end of the long bolt, but DO NOT completely tighten at this time.

STEP 3: Position the tote box on the rails, align the four holes in the base of the box with the holes in the braces and secure these with the four 1/4-28 x 3/4" capscREWS and 1/4 SAE flat washers (on topside) and with the 1/4-28 hex locknuts on the underside of the rails. Securely tighten these first, then tighten the 3/8 hex locknut on the end of the long bolt.

STEP 4: Insert a hair pin through the hole in one end of one of the two support pins, then insert this pin into the top holes in the braces on the inside of the Rider front end. Install a 1" long hairpin in the other end to retain. **NOTE!** This pin can permanently remain in this position.

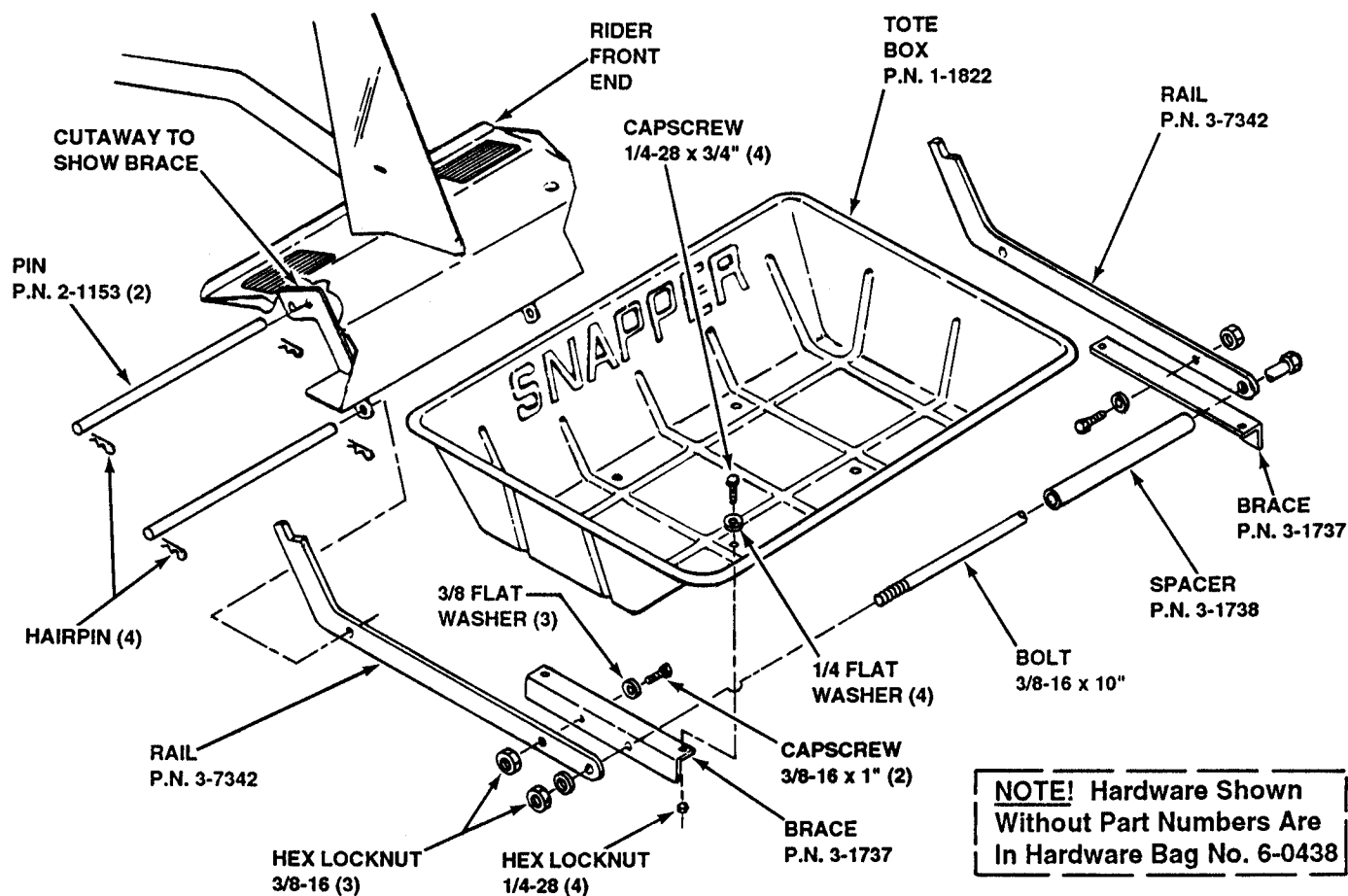

INSTALLING/REMOVING CARRIER

TO INSTALL: Guide the side rails of the carrier assembly between the front end braces, lift up to align holes in rails with lower holes in the braces, then insert the remaining support pin through the holes and secure with hairpins.

TO REMOVE: Remove the hairpin and pull the support. hold the carrier box to prevent it from dropping on your feet as the pin is pulled. After separating the carrier from the Rider, insert the pin in the side rail holes and install the pin to prevent losing these items.

SNAPPER®McDonough, GA., 30253 U.S.A.