

Operator's Manual Model 5116

5116 TRACTOR
MFG. NO. 1690684

36 INCH MOWER
MFG. NO. 1690710

42 INCH MOWER
MFG. NO. 1690708

8111

FORM - 1670778

Simplicity

Contents

SAFETY RULES	1	TROUBLESHOOTING & REPAIR	17
DECALS	3	CONTENT OF SECTION	17
MOWER INSTALLATION & REMOVAL	4	TROUBLESHOOTING PROCEDURES	17
OPERATION	7	BATTERY REPLACEMENT	19
CONTROLS	7	JUMP STARTING	19
CHECKS BEFORE STARTING	8	TRACTOR DRIVE BELT REPLACEMENT	20
STARTING THE ENGINE	8	BELT REPLACEMENT - 36" MOWER	22
SELECTING GEARS & ENGINE SPEED	8	BELT REPLACEMENT - 42" MOWER	22
STARTING & STOPPING	8	ADJUSTMENTS	24
BEFORE LEAVING OPERATOR'S POSITION	9	TRACTOR ADJUSTMENTS	24
MOWING PATTERN & TIPS	9	Parking Brake	24
NORMAL CARE	10	Brake Rod	24
DETERMINING OPERATING TIME	10	Clutch Rod	25
NORMAL CARE SCHEDULE	10	Drive Pulley Belt Stops	25
RAISING HOOD/SEAT DECK	10	MOWER ADJUSTMENTS	26
CHECKING/ADDING GASOLINE	10	Drive Belt Tension	26
LUBRICATING THE TRACTOR	11	PTO Pulley Belt Stops	27
CHECKING THE FUEL FILTER	11	Mower Belt Stops - 36" Mower	27
CHECKING THE BATTERY FLUID LEVEL	12	Mower Belt Stops - 42" Mower	28
CHECKING THE TIRE PRESSURES	12	Mower Levelling - 36" Mower	28
CLEANING BATTERY & CABLES	12	Mower Levelling - 42" Mower	29,30
TRACTOR NORMAL STORAGE	12	SEAT ADJUSTMENT	31
TRACTOR OFF-SEASON STORAGE	12	SPECIFICATIONS	32
STARTING AFTER STORAGE	13	ATTACHMENTS & ACCESSORIES	33
LUBRICATING THE MOWER	13	COMMON REPLACEMENT PARTS	34
SHARPENING & BALANCING THE BLADES	15	PARTS MANUAL AVAILABLE	35
MOWER OFF-SEASON STORAGE	16		

Safety Rules



Read these safety rules and follow them closely. Failure to obey these rules could result in loss of control of vehicle, severe personal injury to yourself or bystanders, or damage to property or equipment. The triangle  in the text signifies important cautions or warnings which must be followed.

GENERAL

- Read the Operator's Manual carefully. Be thoroughly familiar with the controls and the proper use of the equipment.
- Never allow children to operate the machine. Do not allow adults to operate it without proper instruction.
- Do not carry passengers.
- Use only attachments or accessories designed for your machine. See your dealer for a complete list of recommended attachments or accessories.
- Keep the area of operation clear of all persons, particularly small children and pets.
- Never direct discharge of material toward bystanders.
- Make sure:
 - a. tractor and attachments are in good operating condition,

- b. all safety devices and shields are in place and in good working condition, and
- c. all adjustments are correct.

PREPARATION

- Handle gasoline with care - it is highly flammable.
 - a. Use approved gasoline container.
 - b. Never remove the fuel tank cap or add gasoline to a running or hot engine, or fill the fuel tank indoors. Wipe up spilled gasoline.
- Do not run the engine indoors. Exhaust fumes are deadly.
- Clear the work area of objects which might be picked up and thrown by attachments.

- Disengage all attachment clutches and shift into neutral before attempting to start the engine.

- Wear heavy footwear. Do not operate tractor when barefoot or when wearing open sandals and canvas shoes.

OPERATION

- Stop tractor engine, disengage power to attachment(s), set parking brake, remove the key and wait for moving parts to stop before leaving the operator's position for any reason, such as to unclog attachment chutes or to make repairs or adjustments.
- Stop tractor and attachments and inspect for damage after striking a foreign object. Repair any damage before re-starting and operating the equipment.
- Watch out for traffic when crossing or operating near roadways.
- Operate only in daylight or in good artificial light.
- Never make any adjustment while the engine is running.

- Operate only up and down the face of slopes; never across the face. Do not stop or start suddenly on slopes.
- Reduce speed on slopes and in sharp turns to prevent tipping or loss of control. Use extreme caution when changing direction on slopes.
- Be especially careful not to touch tractor or attachment parts which might be hot from operation. Allow such parts to cool before attempting to maintain, adjust, or service.
- Stay alert for holes in the terrain and other hidden hazards. Be extra careful when operating on wet, slippery surfaces.
- If equipment begins to vibrate abnormally, disengage power to attachments and stop engine at once. Inspect for damage and correct before starting up tractor.
- Use care when pulling loads or using heavy equipment.
 - a. Use only draw bar hitch point.

- b. Limit loads to those you can safely control.
 - c. Do not turn sharply. Use care when backing.
 - d. Use weights when recommended in the tractor or attachment Operator's Manual.
- Disengage power to attachment(s) when transporting or not in use.

MAINTENANCE & STORAGE

- Keep all nuts, bolts, and screws tight to be sure the equipment is in safe working condition.
- Do not change the engine governor settings or overspeed the engine.
- To reduce fire hazard, keep the engine and mower free of grass, leaves and excess grease.
- Never store the equipment with gasoline in the tank inside a building where fumes may reach on open flame or spark. Allow the engine to cool before storing in any enclosure.

Decals

ALL WARNING, CAUTION, and instructional messages on your tractor and mower should be carefully read and obeyed. Personal bodily injury can result when these instructions are not followed. The information is for your safety and it is important. The safety messages on this page are on your tractor and mower.

DANGER

1. Stand clear of discharge opening.
2. Do not operate mower without discharge deflector or entire grass collector system properly installed.

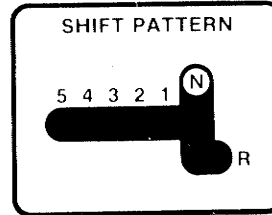
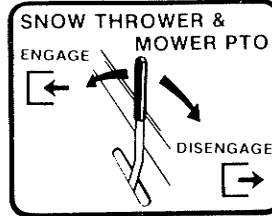

CAUTION

- Keep all shields in place.
- Keep hands, feet and clothing away from power driven parts.
- Keep people and pets a safe distance away from machine.
- For your safety to start tractor transmission shift lever must be in neutral and PTO disengaged. Set parking brake.
- Before operating read safety instructions in operator's manual.

Before leaving operator's position:

- Shift transmission to neutral.
- Disengage PTO.
- Set parking brake.
- Shut off engine and remove key.
- Wait for all movement to stop before servicing.

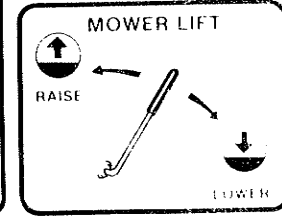
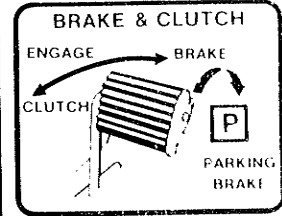

DANGER

keep hands & feet
from under mower

Mower Installation & Removal



WARNING

Engage the parking brake, disengage the PTO, stop the engine and remove the key before attempting to install or remove the mower.

NOTE

If there are two holes in the mower lift bracket (D, figure 1), make sure the chain (E) is connected to the rear hole.

INSTALLATION

1. Place the tractor and mower on a flat, level surface, such as concrete, with the mower on the right side of the tractor.
2. The PTO rod must be attached to mower PTO arm before sliding mower under tractor. Insert the end of the PTO rod from the right-hand side and work the "S" bend around until rod appears as in figure 1.
3. Using the mower height control lever, place the mower in lowest cutting height.

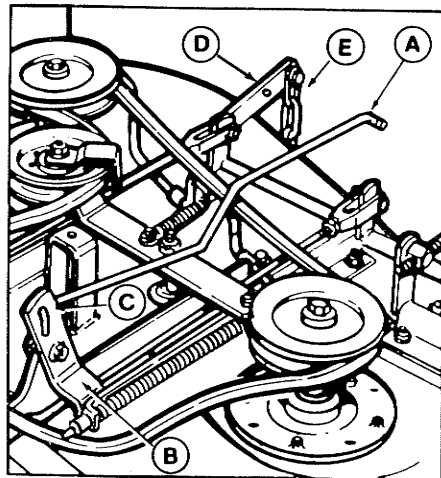

Figure 1. PTO Rod Connection - 36" Mower Shown

- A. PTO Rod
- B. PTO Arm
- C. "S" Bend
- D. Lift Bracket
- E. Chain

4. Turn the front wheels toward the left.
5. Place the lift lever fully forward so that lift arm (B, figure 2) is in lowest position.
6. Slide the mower under the tractor so that the lift chain (C, figure 2) is under the lift arm (B).

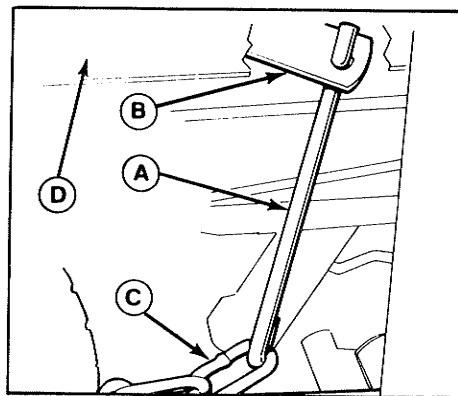

Figure 2. Installing Lift Link (Seen from right-hand side)

- A. Lift Rod
- B. Lift Arm
- C. Lift Chain
- D. Tractor Frame

7. The lift rod (A, figure 2) must be hooked into the lift arm (B) as shown. Insert the lift rod into the hole from the left side then pivot back and down.
8. Slip the chain (C) onto the lift rod (A). If chain has four links, use only three links, by hooking second link onto lift rod.

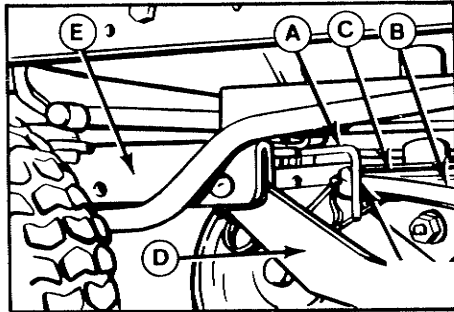

Figure 3. L.H. Belt Stop - All Mowers

- A. Belt Stop
- B. Belt
- C. PTO Pulley
- D. Mower Hitch Arm
- E. Tractor Hitch

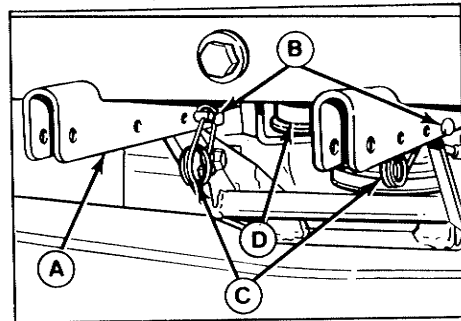

Figure 4. Mower Hitch Attached

- A. Tractor Hitch
- B. Pins
- C. Safety Clips
- D. Drive Belt

9. Insert the mower hitch arms in the tractor hitch (figure 3). Align the holes in the hitch arms with the rear holes in the tractor hitch. Insert the pins (B, figure 4) from the outside and install the clips (C).

10. Slip the mower drive belt onto the engine PTO pulley (figure 3) loosening belt stops as necessary. The left-hand belt stop is shown in figure 3. The right-hand belt stop is shown in figure 5 (36" mower) or figure 6 (42" mower).

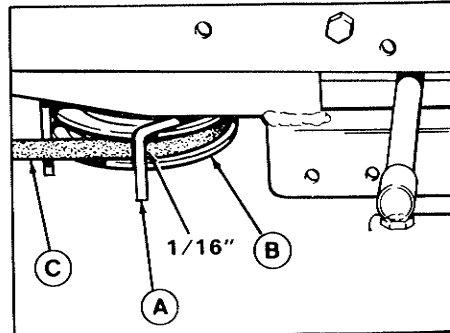

Figure 5. R.H. PTO Pulley Belt Stop, - 36" Mower

- A. Belt Stop
- B. PTO Pulley
- C. Belt

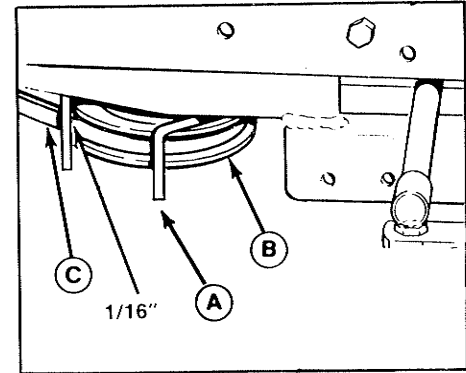

Figure 6. Right-Hand PTO Pulley Belt Stop - 42" Mower

- A. Belt Stop
- B. PTO Pulley
- C. Belt

Installation procedure continued on page 6.

Mower Installation & Removal

11. Insert the rear end of the PTO rod in the hole marked "MOW" in the PTO arm (B, figure 7). Insert the spring clip (C).

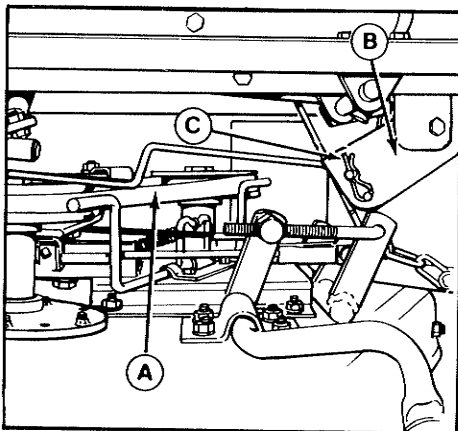

**Figure 7. Installing PTO Rod
(36" Mower Shown)**

- A. PTO Rod**
- B. Tractor PTO Arm**
- C. Spring Clip**

12. If installing mower for the first time, check the following adjustments.
 - a. Mower belt tension (page 26).
 - b. PTO pulley belt stops (page 27).

- c. Mower belt stops (page 27 or 28).
- d. Mower levelling (page 28 or 29).

REMOVAL

1. Place mower in lowest cutting height. Lower the lift lever. Disengage the PTO lever.
2. Remove the belt from the PTO pulley, loosening belt stops as necessary.
3. Remove the spring clip (C, figure 7) and pull PTO rod from hole. Reinstall the spring clip in the rod for storage.
4. Unhook the lift chain (C, figure 2) from the lift link (A). Remove the lift link (A) from the lift arm (B). Store the lift link (A) until reinstallation of mower.
5. Pull the safety clips from the hitch pins. Push the pins out while holding mower hitch up then allow mower to drop down.
6. Turn the tractor wheels as far as they go to the left.
7. Slide the mower out from under the tractor from the right side.

Operation

CONTROLS

Refer to figure 8 for an explanation of tractor and mower controls.

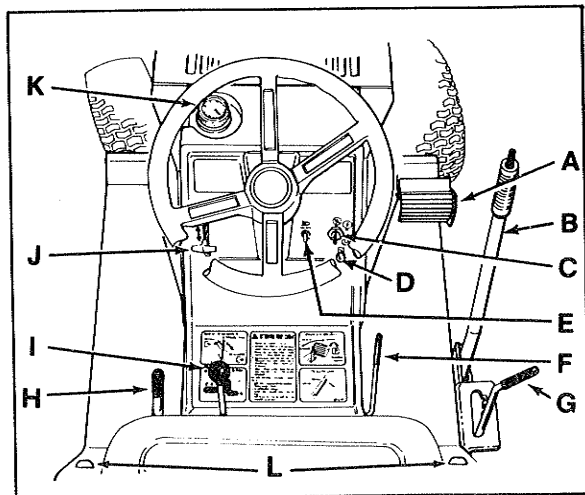

Figure 8. Tractor & Mower Controls

<u>ITEM</u>	<u>NAME</u>	<u>FUNCTION</u>
A	Clutch-Brake Pedal	Disengages tractor drive when pressed down at least halfway. Applies brake when fully depressed. Engages parking brake when latched over footrest.
B	Lift Lever	Lifts and holds attachments in transport position (only required with attachment other than mower). (Optional)
C	Ignition Switch	Operates with key to start, run or stop engine.
D	Choke	Aids in starting a cold engine. Pull knob out to activate choke.
E	Light Switch	Switches headlights on or off.
F	Lift Lever	Lifts and holds mower in transport position.
G	Mower Height Control Lever	Adjusts mower cutting height.
H	PTO (Power Take Off) Lever	Engages and disengages power to attachment. Pull back to disengage.
I	Gear Shift Lever	Shifts transmission gears to control ground speed. Five speeds forward, one speed reverse.
J	Engine Speed Control	Position from SLOW to FAST to control engine speed.
K	Gas Gauge/ Cap	Shows amount of gasoline in the tank and serves as tank cap.
L	Seat Deck Latch	Press button on each side to tilt the seat deck back.

CHECKS BEFORE STARTING

Perform any needed care listed in Table 1, Schedule of Normal Care (page 10). Always make checks listed under "Before Each Use".

STARTING THE ENGINE

1. Set the parking brake.
2. Pull choke knob out to choke engine. A warm engine requires less choking than a cold engine.
3. Lift PTO lever as far as it will go to the rear to disengage the attachment.
4. Set gear shift lever in NEUTRAL.
5. Insert the key into the ignition switch and turn it to START. When engine starts, release the key.
6. Move the engine speed control to SLOW. Warm up the engine by running it for at least a minute before engaging the PTO lever or driving the tractor.

SELECTING GEARS & ENGINE SPEED

Shift gears only with tractor stopped and

clutch-brake pedal fully depressed. Use the gear shift lever to control tractor speed. Use the engine speed control lever to control engine speed. Most mowing is done in third or fourth gear with engine speed between 3/4 and full speed. If the terrain is rough, hilly, or sloping use first or second gear. If the grass is wet or over three inches (76 mm) high, use full engine speed (with low gear) so the mower will have enough power.



WARNING

Slope Operation

Never operate on slopes greater than 30 percent (16.7°) which is a rise of three feet vertically in 10 feet horizontally. When operating on slopes that are greater than 15 percent (8.5°) but less than 30 percent use rear wheel weights (see your dealer). Select slow ground speed before driving onto slope. Mow UP and DOWN the slope, never across the face, use caution when changing directions and DO NOT STOP OR START.

STARTING & STOPPING

1. Clear the work area of any objects which may be caught in or thrown by the mower.
2. Position the front wheels straight ahead. If possible, the first motion should be straight forward or backward.
3. Start the engine.
4. Set engine control for 1/3 to 1/2 speed. Select the gear best suited for conditions.
5. Release the parking brake by unlatching clutch-brake pedal from the foot rest. Keep pedal depressed.
6. Make sure the path in desired direction of movement is clear.
7. If you are ready to mow, engage the mower PTO with moderately fast motion. Engaging PTO too slowly may cause belt wear.
8. Slowly release the clutch-brake pedal to engage clutch and start tractor into motion.

9. Adjust engine speed control to desired speed. Between 3/4 and full speed is recommended for mowing.
10. For a **gradual stop**, press the pedal down only far enough to disengage the clutch. For a **more rapid stop**, press pedal down farther to apply the brake.

2. Set engine speed control to SLOW. Let the engine idle for 20 seconds then turn the key to OFF. Remove the key to prevent unauthorized use of tractor.
3. Lower the attachment.
4. Wait for all moving parts to stop.

practical to mow in a clockwise direction so that clippings are thrown toward the center of the lawn and concentrated for pickup and removal.

Most lawns should be mowed to keep the grass approximately two to three inches (50 to 76 mm) high. Best results are obtained by cutting often and not too short. To help keep a green lawn, never mow more than one third off the height of the grass, or a maximum of one inch (25 mm), in one mowing. For extremely tall grass, set the cutting height at maximum for the first pass, and then reset to the desired height and mow again.

On thick or springy grass or soft ground, the mower rollers may sink into the ground giving too low a cut. Adjust the cutting height as necessary. For best appearance, grass should be cut in the afternoon or early evening (in daylight) when it is free of external moisture.

Where possible, changing patterns occasionally to eliminate matting, graining or a corrugated appearance.

MOWING PATTERN & TIPS

For the first use of the mower choose a smooth level area. Cut long straight strips overlapping slightly.

The size and type of area to be mowed determine the best mowing pattern to use. Obstructions such as trees, fences and buildings must also be considered. Where possible, make one or two passes in a clockwise direction around the outside of the area to keep cut grass off fences and walks. The remainder of the mowing should be done in a counterclockwise direction so the clippings are dispersed on the cut area.

Where possible, keep the left side of the mower toward trees, posts, or other obstacles on the first pass around obstacles to keep hand trimming to a minimum.

On moderate size, frequently mowed lawns where grass is light and dry, it is sometimes



WARNING

To reduce fire hazard keep the engine, tractor and mower free of grass, leaves and excess grease.



WARNING

Never store the tractor where gasoline fumes can reach an open flame or spark.

BEFORE LEAVING OPERATOR'S POSITION

1. Stop tractor motion by depressing the clutch-brake pedal. Set the parking brake. Disengage the PTO.

Normal Care

DETERMINING OPERATING TIME

Determining operating time is easily accomplished if the tractor is equipped with an optional hourmeter. If not, multiply the time it takes to do one job by the number of times you've done the job.

NORMAL CARE SCHEDULE

A schedule for normal care is provided in Table 1.

RAISING HOOD/SEAT DECK

To raise the hood, pull the sides of the hood outward near the dash and tilt hood forward. To raise the deck, press the two buttons (L, figure 8) and tilt seat deck back.

CHECK/ADD GASOLINE

Remove the gas gauge/cap. Fill the tank with clean, fresh, leaded or low-lead regular grade gasoline. The use of lead-free gasoline produces fewer combustion deposits, but may shorten valve life if carburetor adjustment is too lean. Also refer to the engine manual.

Care Required	See	Schedule					
		Before First Use	Before Each Use	Every 5 Hours	** Every 25 Hours	Every 100 Hours	*** Spring and Fall
Check gas gauge	P. 10	•	•				
Check tractor & mower for loose nuts, screws, bolts, oil leaks, etc.		•	•	•			
Check engine oil level		•	•	•			
Clean engine & air filter					•		
Change engine oil*					•		•
Lubricate tractor & mower	P.11,13	•			•		
Check battery fluid	P. 12	•			•		
Clean battery & cables	P. 12					•	
Clean/sharpen blades	P. 15					•	
Inspect spark plug(s)						•	
Check fuel filter	P. 11					•	
Check tire pressures	P. 12	•			•		

*Change original engine oil after first 5 hours of operation.
 **More often in hot (over 85° F: 30° C) weather or dusty operating conditions.
 ***Only if tractor is used in both summer (over 40° F) and winter (under 40° F: 4.5° C).

Table 1. Schedule of Normal Care - Tractor & Mower

LUBRICATE TRACTOR

Lubricate the tractor as shown in figures 9 thru 12. When a grease gun is shown, wipe the fitting clean, apply two or three shots of grease, then wipe off excess grease. When an oil can is shown, wipe the area clean, apply a few drops of medium weight (SAE 30) oil, then wipe up drips or spills.

CHECK FUEL FILTER



WARNING

Do not remove fuel filter when engine is hot, as spilled gasoline may ignite. Do not spread hose clamps further than necessary. Insure clamps grip hoses firmly over filter after installation.

The fuel filter is located in fuel line between fuel tank and carburetor. If filter is dirty or clogged, replace as follows.

1. Using a pliers, open and slide hose clamps from fuel filter. Drain fuel into an approved container.
2. Remove hoses from filter.

3. Install new filter in proper flow direction in fuel line. Secure by re-clamping with hose clamps. See warning at beginning of procedure.

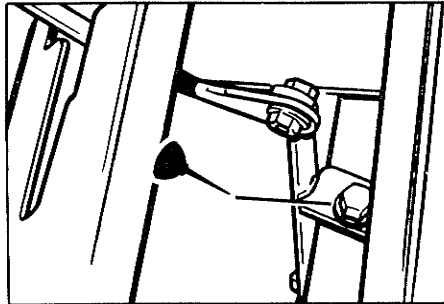

Figure 9. Shift Lever Lubrication

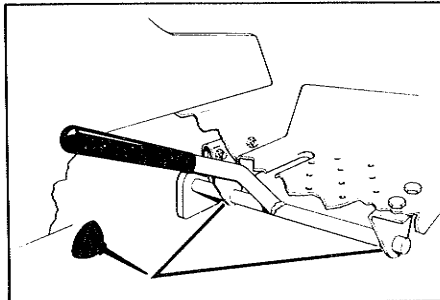

Figure 10. PTO Lever Lubrication

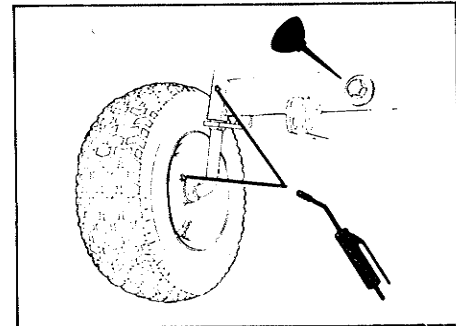

Figure 11. Front Axle Lubrication
(Two grease fittings on each side)

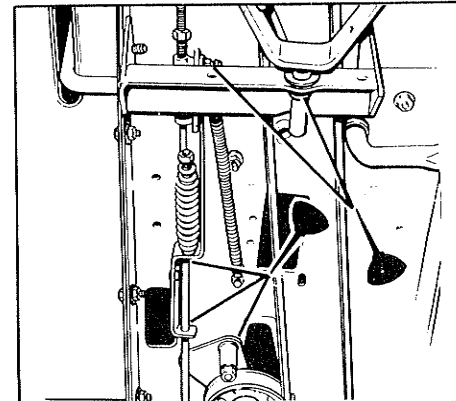

Figure 12. Clutch & Brake Rod
Lubrication

CHECK BATTERY FLUID LEVEL

1. Raise the seat.
2. Remove filler caps, one at a time.
3. Fluid must be even with bottom of split ring full mark (figure 13). If not, add distilled water.
4. Reinstall filler caps.

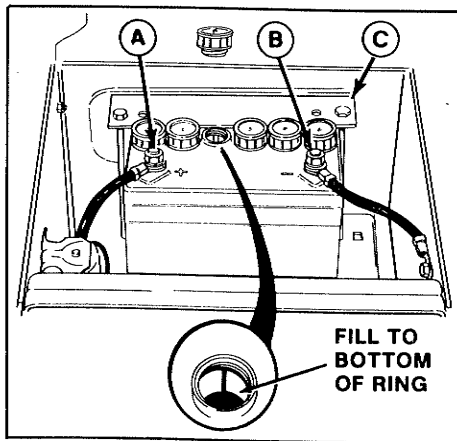

Figure 13. Battery

- A. Positive Terminal
- B. Negative Terminal
- C. Battery Clamp

CHECK TIRE PRESSURES

Check air pressure of all four tires. Front tires should be 12 to 15 psi. Rear tires should be 6 to 8 psi. A gauge with one-pound markings will be necessary for an accurate check.

CLEAN BATTERY & CABLES



WARNING

For your personal safety when removing or installing battery cables, always disconnect the negative cable **FIRST** and reconnect it **LAST**. The positive battery terminal can easily be shorted to the tractor frame by a wrench or other tool if this is not done.



WARNING

Be careful when handling the battery. Avoid spilling electrolyte. Keep flames and sparks away from the battery.

1. Disconnect the cables from the battery, negative cable first (figure 13).
2. Remove the battery clamp, then remove the battery.

3. Scrub the battery, cables, and battery compartment with baking soda and water.
4. Clean the battery terminals and cable clamps with a wire brush. Coat the terminals with petroleum jelly or grease.
5. Reinstall battery and clamp (figure 13).
6. Connect cables, positive cable first.

TRACTOR NORMAL STORAGE

Clean all grass and dirt from the mower. To protect your tractor, store it in an enclosed, dry area. Do not store it in an enclosure where fumes from the fuel tank could reach an open flame. Clean the seat with vinyl cleaner.

To store your tractor in a cold area between winter snow removal jobs, we suggest that you fill the fuel tank at the completion of each job to prevent water condensation in the fuel tank.

TRACTOR OFF-SEASON STORAGE

When the tractor is to be stored for two months or longer, take precautions as follows:

**WARNING**

Keep open flame or spark away from flammable gasoline when working near the fuel tank. Never store tractor where gasoline fumes reach an open flame or spark.

1. To empty or prepare fuel tank:
 - a. Run tractor engine until it stops from lack of fuel, or:
 - b. Use a gasoline stabilizer. This additive, available from your dealer, prevents formation of gum and varnish for up to one year. With the additive, fuel may remain in your tank for long periods.
2. Change engine oil while the engine is still warm. Record the type and weight of oil put in crankcase.
3. Remove spark plug(s). Pour one ounce (30 ml) of SAE 30 oil into engine through spark plug hole(s). Crank engine a few times to distribute oil and then reinstall the spark plug(s).
4. Lubricate tractor (see page 11).

5. Check battery fluid level (page 12). Battery life will be extended if it is removed and stored in a cool, dry place, fully charged.
6. Clean tractor thoroughly. Coat all exposed bare metal parts with a good quality paint (obtainable from your dealer) or a light film of grease or oil.

STARTING AFTER STORAGE

1. Replace battery, if removed. Be sure terminals and clamps are clean (see page 12).
2. Remove spark plugs and wipe dry. Crank engine a few times to blow excess oil out of plug holes. Then reinstall the plugs.
3. Fill fuel tank with fresh gasoline (unless a fuel stabilizer was used).
4. Clean engine fins and air filter. (See engine manual.)
5. Check battery fluid level and tire pressures. (See page 12).
6. Start the engine outdoors. Do not run engine at high speeds immediately after starting.

LUBRICATE MOWER

Lubricate all points where metal rubs against metal. For the 36" mower, lubricate the points shown in figures 14 thru 16. For the 42" mower, lubricate the points shown in figure 17 thru 19. Use an oil can with medium weight (SAE 30) oil. Brush and wipe dirt and grass from the area before applying oil. Wipe up drips or spills. Keep oil off belts and pulleys.

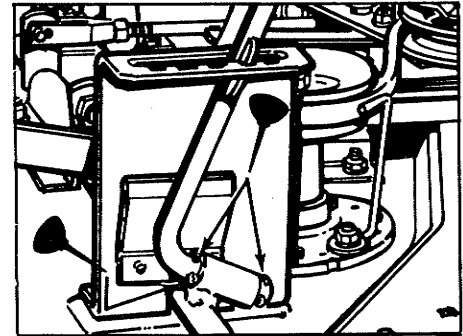

Figure 14. Lubricate Height Control Lever & Point Where Roller Bar Contacts Bracket.

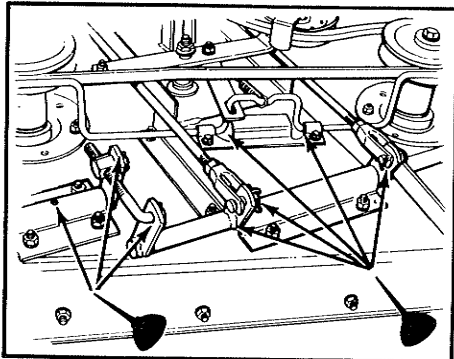

Figure 15. Lubricate Brake Lever, Clevises, & Levelling Rod.

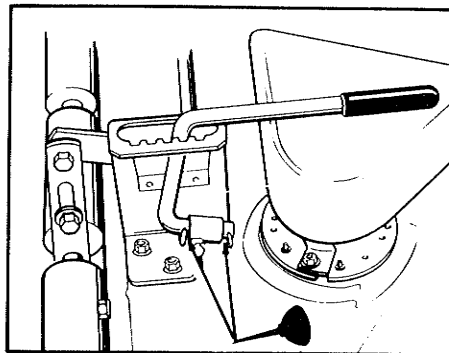

Figure 17. Lubricate Height Control Lever & Point where roller bar Contacts Bracket.

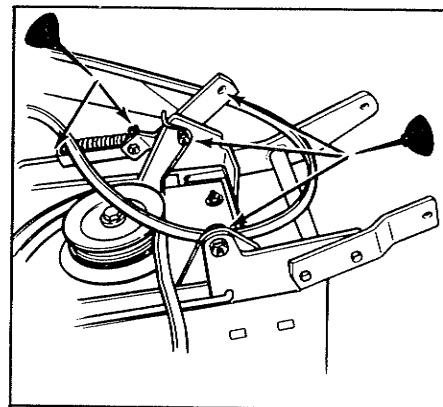

Figure 19. Lubricate Hitch, PTO Rod & PTO Arm.

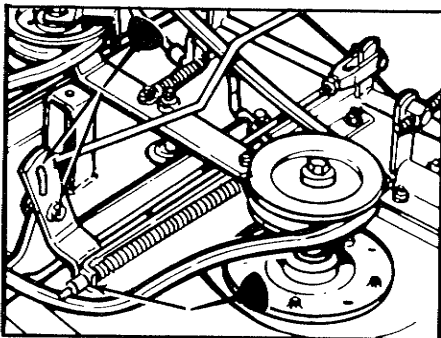

Figure 16. Lubricate Hitch, PTO Rod and PTO Arm.

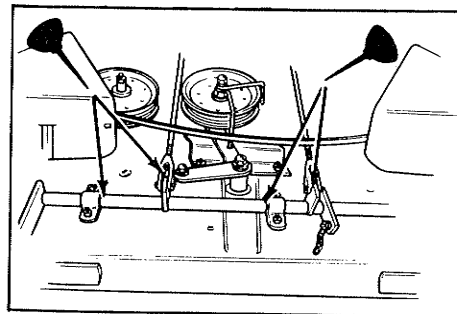

Figure 18. Lubricate Clevises & Two Points Where Roller Bar Contacts Brackets.

CLEAN, SHARPEN & BALANCE BLADES

1. Remove the mower from the tractor.
2. Position the mower as in figure 20. Secure the mower so it will not fall or slide.



WARNING

Do not handle the sharp mower blades with bare hands. Avoid touching the cutting edge. Careless or improper handling of blades may result in serious injury.

3. Remove any dirt or foreign matter from inside the mower deck and blade.
4. To remove the blade for sharpening use a wooden block to hold blade while removing the capscrew (figure 20).
5. Use a file to sharpen blade to fine edge. Remove all nicks and dents in blade edge. If blade is severely damaged, it should be replaced.

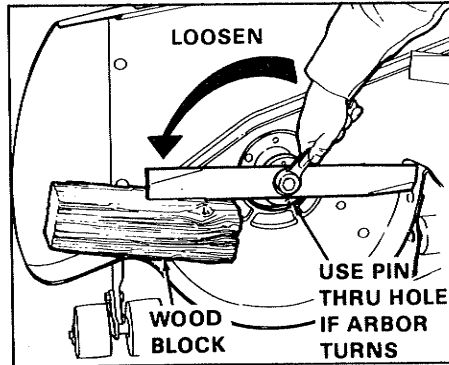

Figure 20. Removing Blade

6. Check and balance blade. Use a balancing machine or the fixture shown in figure 21. Center the blade on a nail lubricated with a drop of oil. A balanced blade will remain level. File material off heavier end of blade until it is balanced.



WARNING

Blade mounting capscrews must be installed with the cup washer and spline washer and then securely tightened. Torque blade mounting capscrews to 50 ft. lbs. (68 N.m).

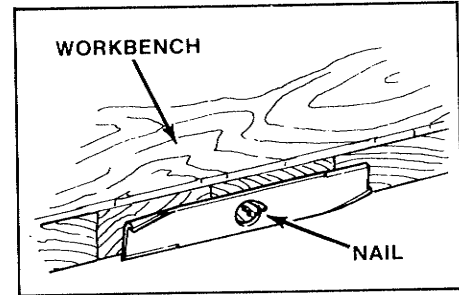

Figure 21. Balancing Blade

7. Reinstall each blade with the tabs pointing up toward deck and secure with a capscrew, cup washer, and spline washer. Be sure all splines are aligned and washer is flush against blade. Use a wooden block to prevent blade rotation and torque capscrew to 50 ft. lbs. (68 N.m) (figure 22).

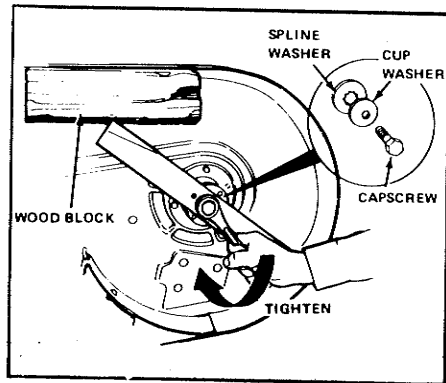

Figure 22. Installing Blade

MOWER OFF-SEASON STORAGE

To protect your mower, store it in an enclosed dry area. To prepare the mower for off-season storage perform the following.

1. Remove mower from tractor. (See Mower Installation and Removal section.)
2. Clean top and underside of mower to remove all grass and dirt.
3. Coat all bare metal surfaces with a good quality paint (available from your dealer) or a light coat of oil to prevent rusting.
4. Lubricate mower (page 13).
5. Check, sharpen and balance the mower blades (page 15).
6. The belt should be stored in a cool, dark place away from heat and sunlight.

Troubleshooting & Repair

CONTENT OF SECTION

This section of the manual provides troubleshooting and repair instructions for the more common and easily corrected problems. For other problems, it is recommended that you contact your dealer.



WARNING

To avoid serious injury, perform maintenance on the tractor or mower only when the engine is stopped and the parking brake engaged. Always remove the ignition key before beginning the maintenance to prevent accidental starting of the engine.

TROUBLESHOOTING PROCEDURES

Troubleshooting procedures are provided in Table 2. To use these procedures, first locate the problem description that best describes the trouble that you have encountered. Check the possible causes one at a time in the order that they are listed.

1. Engine will not start.

- A. Gear shift lever not in neutral-start position. Shift into neutral.
- B. PTO clutch lever not disengaged. Disengage fully.
- C. Out of fuel. Refill fuel tank.
- D. Engine flooded. Push choke knob in & attempt to start.
- E. Circuit breaker tripped. Wait one minute for automatic reset. Replace if defective (see your dealer).
- F. Battery terminals require cleaning. See Normal Care section.
- G. Battery discharged or dead. Recharge or replace.
- H. Wiring loose or broken. Visually check wiring & replace broken or frayed wires. Tighten loose connections.
- I. Solenoid or starter motor faulty. Repair or replace.
- J. Safety interlock switch faulty. Replace if needed. (See your dealer).
- K. Spark plug or points faulty, fouled, or incorrectly gapped. Clean & gap or replace.
- L. Water in fuel tank. Drain fuel & refill with fresh fuel.
- M. Old stale gas. Drain fuel & replace with fresh fuel.

2. Engine starts hard or runs poorly.

- A. Fuel mixture too rich. Push choke knob in. If problem still exists, clean air filter.
- B. Carburetor adjusted incorrectly. See your engine manual.
- C. Spark plug or points faulty, fouled, or incorrectly gapped. Clean and gap or replace.

Table 2. Troubleshooting

Troubleshooting & Repair

3. Engine knocks.

- A. Low oil level. Check/add oil as required.
 - B. Using wrong grade oil. See Normal Care section.
-

4. Excessive oil consumption.

- A. Engine running too hot. Clean engine fins, blower screen and air cleaner. See Normal Care section.
 - B. Using wrong weight of oil. See Normal Care section.
 - C. Too much oil in crankcase. Drain excessive oil.
-

5. Engine exhaust is black or smoky.

- A. Dirty air filter. Clean air filter.
 - B. Choke not fully open. Push choke knob in and be sure choke opens fully. If problem still exists, check carburetor adjustment.
-

6. Engine runs, but tractor will not drive or lacks power.

- A. Transmission not in gear. Shift into gear.
 - B. Drive belt slips. (See problem and cause below).
-

7. Drive belt slips.

- A. Clutch or belt tension is out of adjustment. See Adjustment section.
 - B. Pulleys or belt greasy or oily. Clean as required.
 - C. Belt stretched or worn. Replace with correct belt.
 - D. Clutch rod binding in guide. Oil clutch rod. See Tractor Lubrication.
-

8. Brake will not hold.

- A. Brake is incorrectly adjusted. See Adjustment section.
 - B. Brake pads worn & require replacement. See your dealer.
-

9. Tractor handles poorly.

- A. Steering linkage is loose. Check and tighten any loose connections.
 - B. Improper tire inflation. Check and correct (see page 10).
 - C. Wheels are spinning and slipping. Use weights to provide additional stability and traction.
 - D. Moving too fast on slopes. Reduce speed.
-

10. Main tractor drive belt does not stop when clutch-brake pedal is depressed.

- A. Belt stops out of adjustment. See Adjustments section.
 - B. Belt tension out of adjustment. See Adjustments section.
-

TROUBLESHOOTING (MOWER)

1. Mower will not raise.

- A. Lift chain not attached or broken. Attach or repair.
-

2. Uneven cut.

- A. Mower not leveled properly. See levelling adjustment in Mower Adjustment section.
 - B. Tractor tires not inflated equally or properly. See page 10.
-

3. Mower cut is rough looking.

- a. Engine speed too slow. Set for three-fourths to full speed.
- B. Tractor ground speed too fast. Use lower gear.

Table 2. Troubleshooting (cont'd)

3. Mower cut is rough looking (cont'd).

- C. Blades dull & require sharpening. See Normal Care section.
- D. Mower drive belt slipping. Belt oil or worn. Clean or replace belt as necessary.
Readjust belt tension.

4. Engine stalls easily with mower engaged.

- A. Tractor ground speed too fast. Use lower gear.
- B. Engine speed too slow. Set for three-fourths to full speed.
- C. Cutting height set too low when mowing tall grass. Cut tall grass as maximum cutting height during first pass.
- D. Discharge chute jamming with cut grass. Cut grass with discharge pointing toward previously cut area.

5. Excessive mower vibration.

- A. Blade mounting screws are loose. Torque to 50 ft. lbs. (68 N.m). See Normal Care section.
- B. Mower blades, arbors, or pulleys are bent. Check and replace as necessary.
- C. Mower blades are out of balance. Remove, sharpen, and balance blades (see Normal Care section).

6. Excessive belt breakage.

- A. Belt tension too light. Readjust belt tension.
- B. Bent or rough pulleys. Repair or replace.
- C. Using incorrectly belt. See your dealer.

7. Mower drive belt slips or fails to drive.

- A. Mower drive belt out of adjustment. See Adjustment section.
- B. Mower drive belt broken. Replace belt.

BATTERY REPLACEMENT

A dead battery or one too weak to start the engine may not mean the battery needs to be replaced. It may, as an example, mean that the charging system is not working properly or that the battery has lost its charge during storage. First, "Clean Battery & Cables" and "Check Battery Fluid Levels" as described on page 12. Have the battery recharged, if necessary. If there is any doubt about the cause of the problem, see your dealer. If you must replace the battery, remove and install the battery as described in "Clean Battery & Cables".

JUMP STARTING WITH AUXILIARY (BOOSTER) BATTERY

Jump starting is not recommended. First, check the battery as described in "Battery Replacement" above. If jump starting must be done, follow these directions. Both booster and discharged batteries should be treated carefully when using jumper cables. Follow exactly procedures one through five, being careful not to cause sparks.



WARNING

For your personal safety use extreme care when jump starting. Never expose battery to open flame or electric spark — battery action generates hydrogen gas which is flammable and explosive. Do not allow battery acid to contact skin, eyes, fabrics, or painted surfaces. Batteries contain a sulfuric acid solution which can cause serious personal injury or property damage.

1. Set parking brake and place transmission in "NEUTRAL". Turn off lights and other electrical loads.
2. Remove vent caps from both the booster and the discharged batteries. Lay a cloth over the open vent wells on each battery. These two actions help reduce the explosion hazard always present in either battery when connecting a "live" battery to a "dead" battery.
3. Attach one end of one jumper cable to the positive terminal of the booster battery (identified by a red color, "+" or

"P" on the battery case, post or clamp) and the other end of same cable to positive terminal of discharged battery. DO NOT permit vehicles to touch each other, as this could establish a ground connection.

4. Attach one end of the remaining cable to the negative terminal (black color, "-" or "N") of the booster battery, and the other end to a bare metal surface on the frame of your tractor AWAY FROM the battery compartment (do not connect directly to negative post of dead battery). Take care that clamps from one cable do not inadvertently touch the clamps on the other cable. Do not lean over the battery when make this connection.
5. The tractor with the discharged battery should now start.

Reverse the jump starting procedure exactly to remove the jumper cables. Then reinstall the vent caps and throw the cloths away as they may have corrosive acid on them.



WARNING

Any procedure other than the above could result in: (1) personal injury caused by electrolyte squirting out of the battery vents, (2) personal injury or property damage due to battery explosion, (3) damage to the charging system of the booster vehicle or the other immobilized vehicle.

Do not attempt to jump start a vehicle having a frozen battery because the battery may rupture or explode. If a frozen battery is suspected, examine all fill vents of the battery. If ice can be seen or if the electrolyte fluid cannot be seen, do not attempt to start with jumper cables as long as the battery remains frozen.

TRACTOR DRIVE BELT REPLACEMENT

1. Make sure the parking brake is set.
2. Remove mower from tractor.
3. Remove the nut, washer and capscrew (A, figure 23) from the gear shift lever (B). Remember position of hardware for reinstallation.

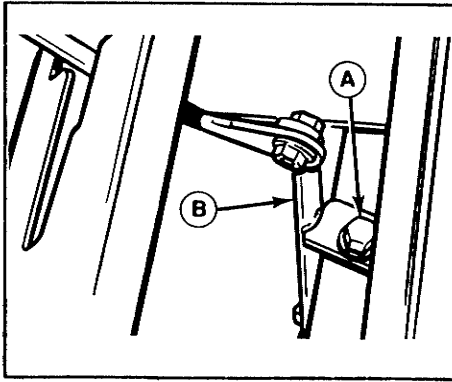

Figure 23. Gear Shift Lever

A. Hardware B. Gear Shift Lever

4. Loosen the nut that secures the idler pulley belt guide (figure 24) and slip the belt out.
5. Remove the belt from the engine drive pulley.
6. Slip the belt out of the belt guide which is bolted to bottom of tractor.
7. Turn the belt sideways to slip it off the transmission pulley.
8. Slip the belt down off the PTO pulley. Remove it from the tractor by slipping it over the gear shift lever.

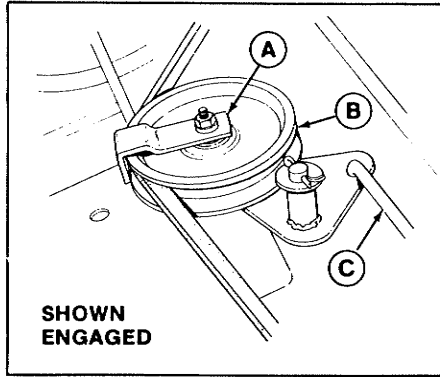

Figure 24. Removing Belt Guide (seen from bottom of tractor)

A. Belt Guide C. Clutch Rod
B. Idler Pulley

9. Install the new belt in reverse order of removal. The belt pattern is shown in figure 25. Be sure the belt guide (figure 24) is positioned in the center area of the belt that contacts pulley. The belt must not touch guide when tractor clutch is engaged (pedal up). To tighten belt guide, hold the capscrew while tightening the nut.

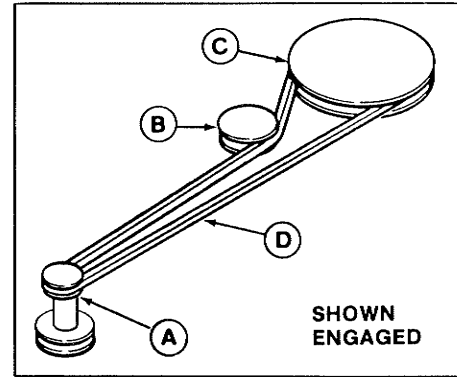

Figure 25. Tractor Belt Pattern

A. Engine Pulley C. Transmission Pulley
B. Idler Pulley D. Drive Belt

BELT REPLACEMENT - 36" MOWER

1. Remove mower from the tractor.
2. Loosen the belt guide (C, figure 26) on the idler pulley (E).
3. Remove the belt from the pulleys.

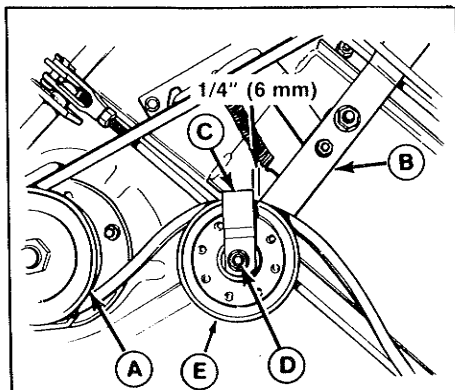

Figure 26. Mower Belt Replacement

- | | |
|-----------------|-----------------|
| A. Arbor Pulley | D. Nut |
| B. Idler Arm | E. Idler Pulley |
| C. Belt Guide | |

4. Install the new belt on the pulleys. The belt pattern is shown in figure 27.

5. Reposition the belt guide on the idler pulley (figure 26). Before tightening the nut (D), position the belt guide so it is 1/4 inch (6 mm) behind the idler arm (B) when viewed from above (figure 26). Hold the belt guide when tightening nut.

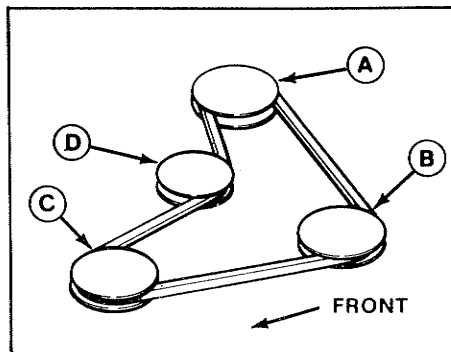

Figure 27. Mower Belt Pattern - 36"

- | |
|--------------------------|
| A. V-Pulley, Right Arbor |
| B. V-Pulley, Left Arbor |
| C. Engine PTO Pulley |
| D. Flat Idler Pulley |

6. Reinstall the mower on the tractor (see Mower Installation). Engage the PTO lever and make sure the belt guide (C, figure 26) does not touch the belt.

7. Check mower drive belt tension and belt stop adjustment as described in Adjustment section. After about two hours of operation, recheck the mower drive belt tension.

BELT REPLACEMENT - 42" MOWER

1. Remove the mower from the tractor.
2. Loosen the left belt stop (D, figure 28) enough to slip the belt off the pulley. Remove the right belt stop (A).

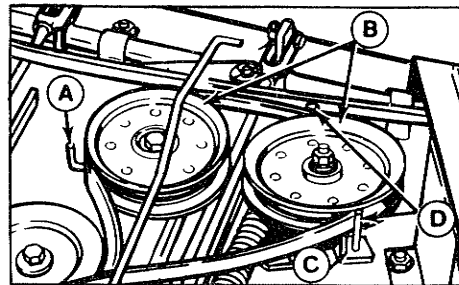

Figure 28. Mower Belt Stops - 42" Mower

- | |
|-------------------------|
| A. Right Belt Stop |
| B. Idler Pulleys |
| C. Idler Pulley Bracket |
| D. Left Belt Stop |

3. Remove the right arbor cover by removing two carriage bolts in front and two capscrews in rear (see figure 29). Remove the nut (H) and lockwasher (I) which secures left arbor cover to the idler pulley. Remove the two capscrews (K) which secure the rear of the left arbor cover.
4. Remove the old belt.
5. Install the new belt on the pulleys. The belt pattern is shown in figure 30. Notice that the "V" side of belt drives the V-pulleys and flat side of belt rides on the flat idler pulleys. Be sure there are no twists in the belt.
6. Reinstall the arbor covers (step 3) and belt stop (step 2).
7. Reinstall the mower on the tractor (see Mower Installation). Check mower drive belt tension and belt stop adjustments as described in Adjustments section. After about two hours operation re-check mower drive belt tension adjustment.

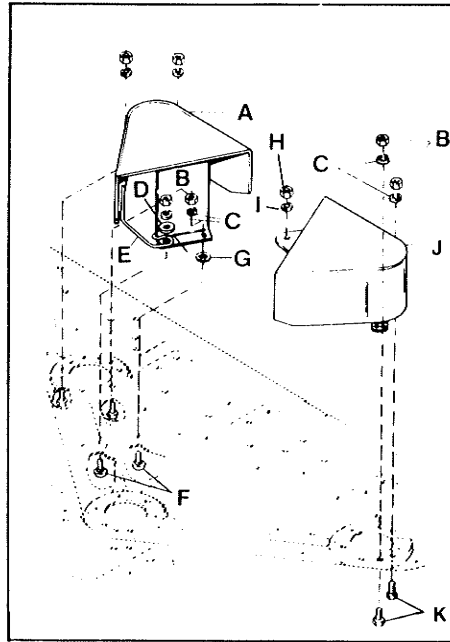

Figure 29. Arbor Covers - 42" Mower

- | | |
|-----------------------|----------------------|
| A. Arbor Cover, Right | G. Nut, Cage |
| B. Nut | H. Nut |
| C. Lockwasher | I. Lockwasher |
| D. Plain Washer | J. Arbor Cover, Left |
| E. Belt Stop | K. Capscrew |
| F. Bolt, Carriage | |

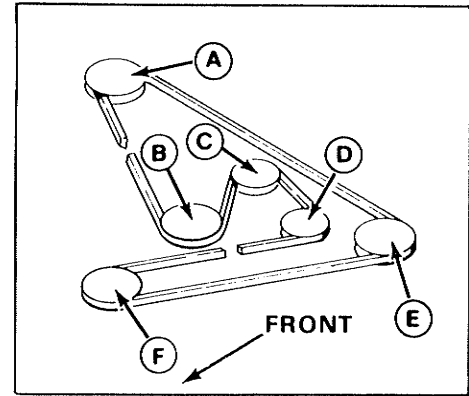

Figure 30. Belt Pattern - 42" Mower

- | |
|--------------------------|
| A. V-Pulley, Right Arbor |
| B. V-Pulley, Front Arbor |
| C. Flat Idler Pulley |
| D. Flat Idler Pulley |
| E. V-Pulley, Left Arbor |
| F. Engine PTO Pulley |

Adjustments



WARNING

Perform adjustment only with engine stopped, key removed, and tractor on level ground.

TRACTOR ADJUSTMENTS - Serial No. 2536 and higher.

For tractors with serial numbers 2536 and higher, perform the following adjustments 1, 2, 3 and 4.

1. Adjust parking brake as follows.

- Place the transmission in gear and release the parking brake. Move the brake rod (I, figure 32) back and forth to be sure there is no tension on the brake pads.
- Push the cam lever (A, figure 31) forward (toward front of tractor) to take out any slack. The gap between lever (A) and stop (B) should be 1/8 inch (0.3 mm). Use a feeler gauge to measure. If not 1/8 inch, perform step C.

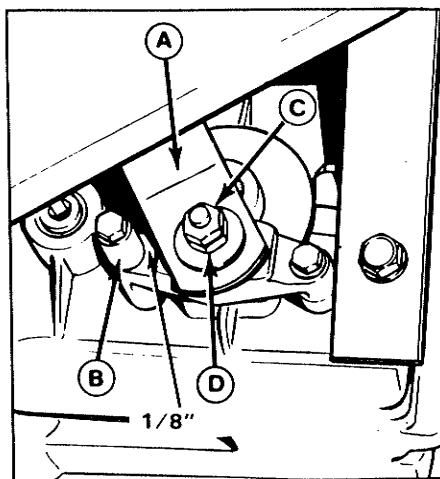

Figure 31. Parking Brake Adjustment

A. Brake Cam Lever
B. Stop

C. Locking Nut
D. Adjusting Nut

- Loosen the locking nut (C). Tighten the adjusting nut (D) to decrease gap or loosen nut to increase gap. Recheck the measurement. When correct, tighten locking nut against adjusting nut.

2. Adjust brake rod as follows.

The clutch-brake pedal must be in up position. With one hand, push rod guide (C, figure 32) as far forward as slot (B) will allow while pulling rod (I) back with other hand. With rod guide in this position, tighten or loosen nut (A) until 1/4 inch of clearance is obtained between nut and end of spring (D).

3. Adjust clutch rod as follows.

- With the pedal up, push the idler pulley (F, figure 32) firmly against the belt. With the pulley in this position, the gap between nut (E) and the rod guide (G) should be 7/8 to 1 inch (22 to 25 mm). If not, tighten nut (E) to decrease gap or loosen nut to increase gap. Recheck measurement.
- Depress and lock the clutch-brake pedal. Loosen the setscrew in the set collar (H). Move the collar against the spring which is located between collar (H) and rod guide (G). Be sure spring is seated as far as possible over rod guide (G). Push the collar

1/4 to 3/8 inch farther to compress the spring then tighten the setscrew.

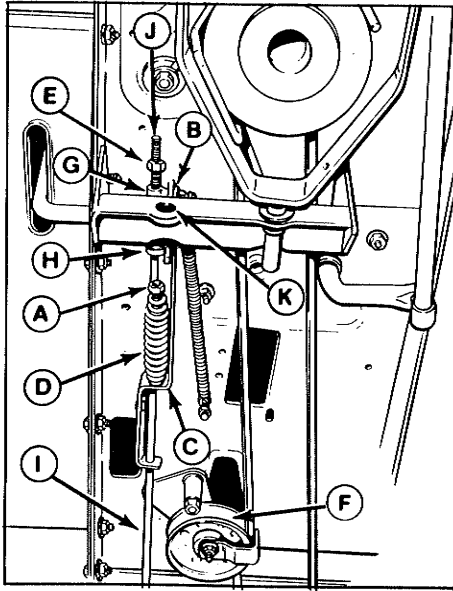

Figure 32. Brake-Clutch Adjustment

- | | |
|------------------------------|---------------------|
| A. Nut | G. Clutch Rod Guide |
| B. Slot (in brake rod guide) | H. Set Collar |
| C. Brake Rod Guide | I. Brake Rod |
| D. Spring | J. Clutch Rod |
| E. Nut | K. Hole, 3/4" Dia. |
| F. Idler Pulley | |

4. Adjust drive pulley belt stops as follows.

There should be 1/8 inch (3 mm) between each belt stop and the belt when the tractor clutch is engaged (pedal up). See figure 33.

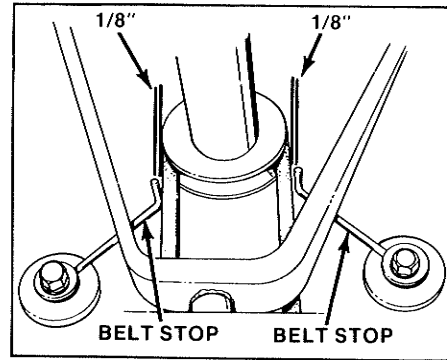

Figure 33. Drive Pulley Belt Stops
TRACTOR ADJUSTMENTS - Serial No. 2535 and lower.

NOTE

If tractor has a 3/4 inch diameter hole (K, figure 32) in bracket as shown, use the preceding tractor adjustments (for serial number 2536 and higher). If not, perform the following adjustments 1, 2, 3 and 4.

1. Adjust parking brake as follows.

- Place the transmission in gear and release the parking brake. Move the brake rod (I, figure 32) back and forth to be sure there is no tension on the brake pads.
- Push the cam lever (A, figure 31) forward (toward front of tractor) to take out any slack. The gap between lever (A) and stop (B) should be 1/8 inch (0.3 mm). Use a feeler gauge to measure. If not 1/8 inch, perform step C.
- Loosen the locking nut (C). Tighten the adjusting nut (D) to decrease gap or loosen nut to increase gap. Re-check the measurement. When correct tighten locking nut against adjusting nut.

2. Adjust brake rod as follows.

The clutch-brake pedal must be in up position. With one hand, push rod guide (C, figure 32) as far forward as slot (B) will allow while pulling rod (I) back with other hand. With rod guide in this position, tighten nut (A) against spring until spring is snug but not compressed.

3. Adjust clutch rod as follows.

- a. With the pedal up, push the idler pulley (F, figure 32) firmly against the belt. With the pulley in this position, the gap between nut (E) and the rod guide (G) should be $9/16$ to $5/8$ inch (14 to 15 mm). If not tighten nut (E) to decrease gap or loosen nut to increase gap. Recheck the measurement.
- b. Depress and lock the clutch-brake pedal. Loosen the setscrew in the set collar (H). Move the collar against the spring which is located between collar (H) and rod guide (G). Be sure spring is seated as far as possible over rod guide (G). Push the collar $7/16$ to $9/16$ inch farther to compress the spring and tighten the setscrew. (When moving the set collar be careful not to move the rod.)

4. Adjust drive pulley as follows.

There should be $1/8$ inch (3 mm) between each belt stop and the belt when the tractor clutch is engaged (pedal up). See figure 33.

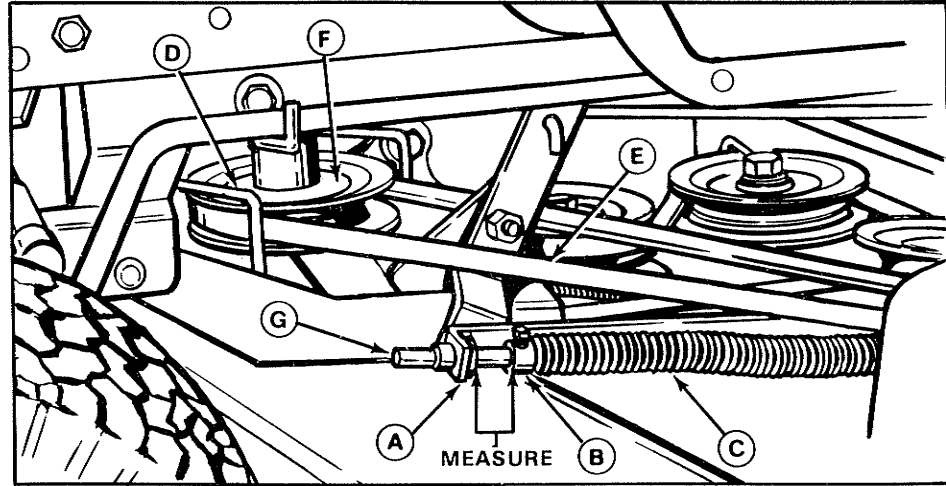

Figure 34. Mower Drive Belt Tension Adjustment - 42" Mower Shown.

- | | |
|------------------|----------------------|
| A. PTO Rod Guide | E. Drive Belt |
| B. Set Collar | F. Engine PTO Pulley |
| C. Spring | G. PTO Rod |
| D. Belt Stop | |

MOWER ADJUSTMENTS

Mower Drive Belt Tension Adjustment - All Models

If the mower belt slips or fails to drive, the mower belt tension may need adjustment. To check, proceed as follows.

1. Place the mower in high cut, using height control lever. Place the PTO lever in engaged position.
2. Measure the distance between the PTO rod guide (A) and the set collar (B). For the 36" mower the measurement should be $3/8$ to $1/2$ inch (10 to 13 mm). For the 42" mower the measurement should be one inch (25.4 mm).

3. Place the PTO lever in disengaged position.
4. Loosen the setscrew in the set collar (B). Move the rod (G) forward to increase gap, or backward to decrease gap. Retighten the setscrew.
5. Repeat the adjustment as necessary until the distance measures as described in step 2 with the PTO lever in engaged position.
6. Check the adjustments of the PTO pulley belt stops and the mower belt stops.

PTO Pulley Belt Stops Adjustment - All Models

There are two belt stops at the PTO pulley; one on the left (figure 34) and one on the right (figure 35 or 36). With the PTO lever engaged, measure the distance between the belt stop and the belt. There should be 1/16 inch (1.5 mm) clearance between each belt stop and the belt. To adjust a belt stop, loosen its mounting capscrew, move the belt stop, and retighten the capscrew. Recheck the measurement. If a 1/16 inch clearance cannot be achieved without touching the pulley, place belt stop as close as possible without touching pulley.

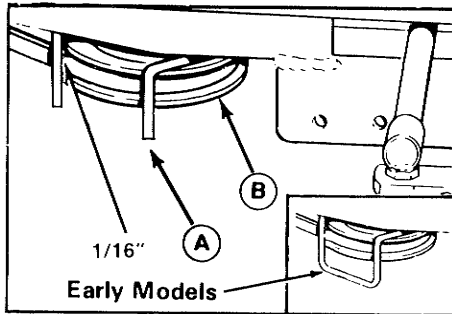

Figure 35. Right Hand Belt Stop, PTO Pulley - 42" Mower
 A. Belt Stop B. Drive Belt

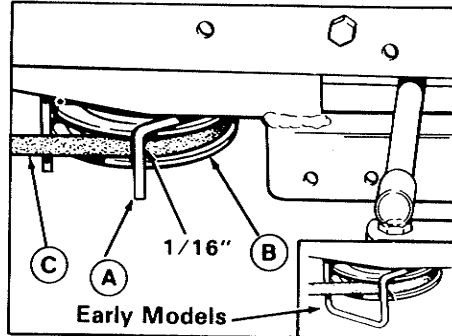

Figure 36. Right Hand Belt Stop, PTO Pulley - 36" Mower
 A. Belt Stop C. Belt
 B. PTO Pulley

Mower Belt Stop Adjustment - 36" Mower

The right arbor belt stop should be adjusted so that it is 1/8 inch (3 mm) from the belt with the PTO engaged (see figure 37). If it is not, loosen the nut and lockwasher and move the belt stop until the 1/8 inch clearance is reached. Then retighten the nut while holding the belt stop from moving.

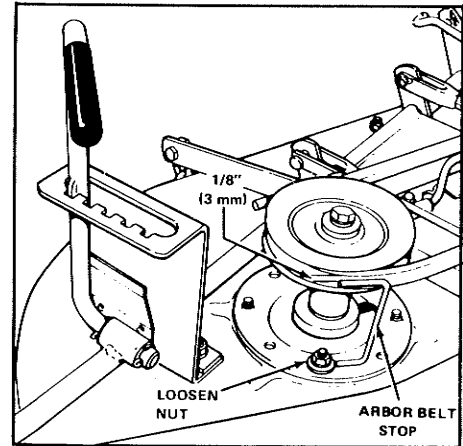

Figure 37. Right Arbor Belt Stop Adjustment - 36" Mower

Mower Belt Stops - 42" Mower

Right Idler Pulley Belt Stop. Make sure the long side of the right belt stop (A, figure 38) is inserted in idler pivot bracket slot (C). There is no adjustment.

Left Idler Pulley Belt Stop. Make sure the belt stop (D) is level with the pulley. If the belt stop is level, each side will be an equal distance from the belt. To reposition the belt stop, loosen the mounting capscrew on the bracket underneath the pulley. Retighten hardware securely.

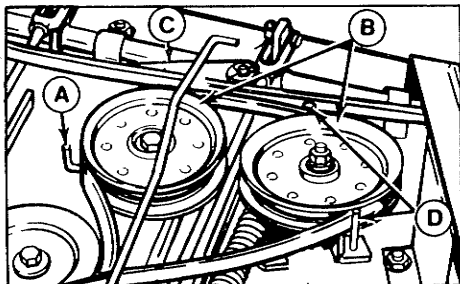

Figure 38. Mower Belt Stops - 42" Mower

- A. Right Belt Stop
- B. Idler Pulleys
- C. Idler Pivot Bracket
- D. Left Belt Stop

Mower Levelling - 36" Mower

If the 36 inch mower is giving an uneven cut, or if one side of the mower cuts at a different height than the other side, then the mower needs levelling. Remember improper tire pressure can also cause an uneven cut. To level the mower, proceed as follows:



WARNING

To avoid accidental starting during levelling check, remove ignition key and remove both spark plug wires and fasten them away from the spark plugs.

1. With the mower installed, place the tractor on a smooth level surface, such as a concrete floor.
2. Check for bent blades, and replace if necessary.
3. Arrange the mower blades so that they are both pointing from side-to-side, perpendicular to the tractor. Engage the clutch.

4. Measure the distance between the outside tips of each blade and the ground. If there is more than 1/8 inch (3 mm) difference between the measurements on each side, proceed to step 5. If there is 1/8 inch or less difference proceed to step 6.

5. Remove the cotter pin holding on the mower levelling rod (figure 39). Shorten the rod to raise the left side of the mower, or lengthen the rod to lower the left side of the mower. Put the levelling rod back in its hold and recheck the measurements. When both sides are the same height, replace the cotter pin in the levelling rod.

6. Disengage mower clutch then arrange the blades so they are facing front to back, parallel with the tractor. Engage mower clutch again.

7. Measure the distance to the ground from the front tip of the left blade and the rear tip of the right blade. The measurements should be equal. If they are not, proceed as follows.

- Remove the cotter pins and pins from the hitch clevises (figure 39). Turn each clevis an equal number of turns in the same direction. Shorten the hitch rods to raise the front of the mower, lengthen the hitch rods to lower the front of the mower.
- Replace pins through clevises and rear suspension arm and recheck measurements. When the mower is level replace and spread cotter pins, and tighten nuts against clevises.

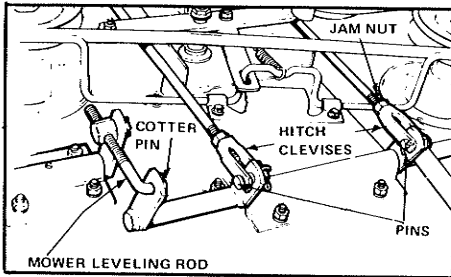

Figure 39. Levelling Mower

Mower Levelling, Side-To-Side - 42" Mower

NOTE

The purpose of levelling the mower is to achieve an even grass cut. Remem-

ber that improper or unequal tire pressure will cause an uneven cut. Also, different terrains may require different side-to-side adjustments. If you don't achieve an even cut with the mower level, try raising one side slightly higher.



WARNING

To avoid accidental starting during levelling check, remove the ignition key and remove both spark plug wires and fasten them away from the spark plugs.

- Tractor and mower must be on a level surface. The tires must point straight forward.
- Place the mower in highest cutting position and place the mower lift lever in the lowered position.
- Disengage the mower clutch and position the blades so they are pointing side-to-side.
- Engage the clutch.

- Measure the distance from the outside tips of the blade to the ground. If the difference between the two measurements is less than 1/8 inch (3 mm), the mower is level. If not, proceed with next steps.

NOTE

It will be easier to make adjustments with mower in lowest cutting position. To recheck measurements, reposition mower in highest cutting position.

- Loosen the two capscrews (A, figure 40) and flange nuts (B) in the right mower hitch.

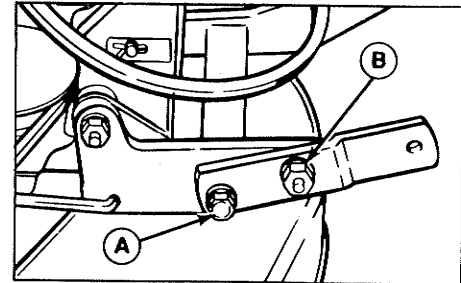

Figure 40. Mower Hitch (shown removed from tractor)

A. Capscrews

B. Flange Nuts

7. Loosen the shoulder bolt (A, figure 41) and raise or lower mower as necessary to level it. Retighten the shoulder bolt.
8. Retighten the two capscrews and flange nuts (B, figure 40).
9. Check the measurements and readjust as necessary.
10. Check Mower Levelling, Front-to-Back, as described in the following procedure.

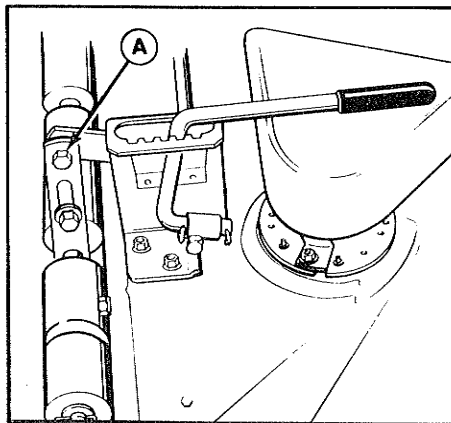

Figure 41. Shoulder Bolt

A. Shoulder Bolt

Mower Levelling, Front-to-Back, 42" Mower



WARNING

To avoid accidental starting during levelling check, remove the ignition key and then remove both plug wires and fasten them away from the spark plugs.

1. Place tractor and mower on a level surface. Check side-to-side adjustment first (page 29).
2. Place the mower in the highest cutting position, and place the mower lift lever in the lowered position. The front tires must point straight forward.
3. Arrange the blades so that they are pointing forward and back, parallel with the tractor. Engage the mower clutch.
4. Measure the distance from the front tip of the center blade to the ground, and note that measurement. (See figure 42.)

5. Measure the distance to the ground from the rear tips of the left and right blades. Compare these measurements with the measurement from the front tip of the center blade. The front tip of the center blade should be 1/4 inch (6 mm) higher than the rear tips of the side blades (figure 42).

NOTE

It will be easier to make adjustments with mower in lowest cutting position. To recheck measurements, reposition mower in highest cutting position.

6. If adjustment is needed, remove the two pins (A, figure 43) by removing the cotter pins. Loosen the jam nuts (C).
7. Turn both turnbuckles the same number of turns, shortening the bail arms to raise the front of the mower and lengthening the bail arms to lower the front of the mower. (One full turn of eyebolt will equal about 1/8 inch.)

8. Replace pins through turnbuckles and height adjustment arm and recheck measurements. When the proper measurement is reached, install new cotter pins through the pins and tighten the jam nuts to the turnbuckles.

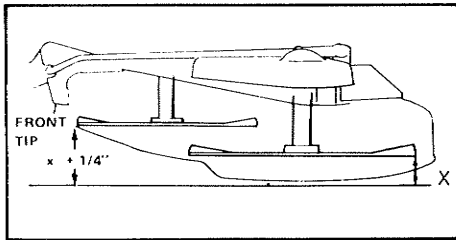

Figure 42. Levelling Mower - 42"

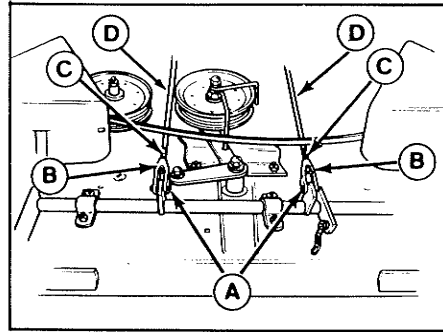

Figure 43. Turnbuckles - 42"

- A. Pins
- B. Turnbuckles
- C. Jam Nuts
- D. Bail Arms

SEAT ADJUSTMENT

The seat can be moved forward or back for operator comfort. To adjust, tilt the seat deck back. Loosen the four capscrews that secure seat, move the seat, then retighten the capscrews. (Seat will be loose when capscrews are loosened.)

If the tractor is equipped with seat springs, the springs can be repositioned for operator comfort. To adjust, lift the seat from the rear. Pull the springs from the holes in the seat deck and push down into desired holes. A lighter operator will want to move the springs more forward.

Specifications

ENGINE

Make: Briggs & Stratton, 4 cycle, air cooled

Model: 401707

Type: 0132-01

Cylinders: 2 Horizontally opposed

Horsepower: 16 (engine manufacturer's rating)

Bore & Stroke: 3.44 x 2.16

Displacement: 40 cu. in.

Starter: 12 volt gear drive

Crankshaft: Vertical

Battery: 12 volt, 39 amp hour

Governor: Mechanical. Full throttle,
no load setting @3400 + rpm.
Idle speed setting @1350 + 100 rpm.

Crankcase Capacity: See engine manual

Air Cleaner: Oil foam with reusable polyurethane
element

Fuel Tank Capacity: 2.2 gallons

TRANSMISSION

Type: Belt drive to transmission, 5 speeds forward
and one reverse

Differential: Bevel gear type

Ground Speeds @ 3400 rpm:

1st gear - 0.86 mph (1.56 km/h)

2nd gear - 1.76 mph (2.8 km/h)

3rd gear - 2.64 mph (4.2 km/h)

4th gear - 3.36 (5.4 km/h)

5th gear - 3.97 mph (6.4 km/h)

Reverse - 1.32 mph (2.1 km/h)

DIMENSIONS & WEIGHT

Height (at steering wheel): 40 in.

Width: 35.25 in. (895 mm)

Length: 66.5 in. (1.69 m)

Clearance (front axle): 10.2 in. (259 mm)

Clearance (transmission): 5.5 in. (139 mm)

Wheel Base: 48.2 in. (1230 mm)

Turning Radius (to inside front wheel): 24 in. (610 mm)

Front Tires: 13 x 6.50-6 Pneumatic

Rear Tires: 18 x 9.50 x 8 Pneumatic

Tractor Weight: 403 lbs. (181 kg) (approx.)

36" Mower Weight: 81 lb. (37 kg) (approx.)

42" Mower Weight: 112 lb. (49 kg) (approx.)

SPECIFICATIONS SUBJECT TO CHANGE WITHOUT NOTICE

Optional Attachments

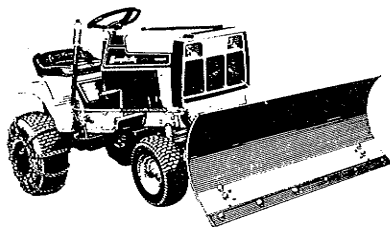

42" DOZER BLADE - For snow removal and light dozing of dirt, gravel, etc.



GRASS CATCHER - For the best lawn appearance (36" mower only)

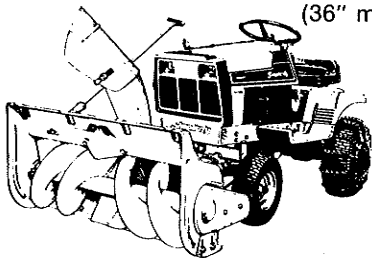

36" SNOWTHROWER - Efficient single stage operation to handle the heaviest of snows.

ENGINE DRIVEN VACUUM COLLECTOR - For big-job grass and leaf collection.

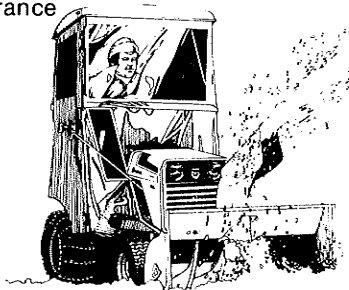
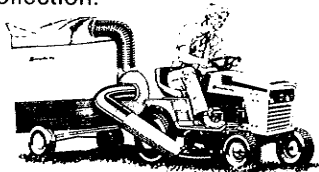

SNOW CAB - Shields operator from blowing snow and wind.

Optional Accessories

TIRE CHAINS for traction.

HOURLY METER to record operating time.

SEAT SPRING KIT for operator comfort.

FRONT WEIGHT to improve steering and stability with rear mounted attachment.

REAR WHEEL WEIGHTS to improve traction and stability.

DUMP CART for vacuum collector and hauling chores.

ROVING NOZZLE used with vacuum collector to collect leaves in hard-to-reach places.

NOTE: Some attachments require accessories. See your dealer or the attachment operator's manuals.

Common Replacement Parts

Listed below are part numbers for the more common replacement parts. Use the order form at the back of the manual to order a complete, illustrated parts manual. Only genuine Simplicity replacement parts will assure optimum performance and safety. Do not attempt repairs or maintenance unless proper procedures and safety precautions are followed. For assistance in any area, see your dealer.

<u>QTY PER UNIT</u>	<u>DESCRIPTION</u>	<u>PART NUMBER</u>
1	Drive Belt - engine to transmission	1655069
1	Drive Belt - 36 inch mower	1668065
1	Drive Belt - 42" Mower	1668066
1	Keys - Ignition (2 keys with ring)	122203
2	Sealed Beam Lamp - GE #4411	1665853
1	Interlock Switch - PTO	1665586
1	Interlock Switch - Transmission	1654634
2	Blade - 36" Mower (standard)	1657589
1	Blade-36" Mower (use with grass catcher)	1685172
3	Blade - 42" Mower	1656147
2	*Cotter Pin - levelling clevises	918447
1	Spring Clip - 36" Mower PTO Rod	106787
1	Spring Clip - 42" Mower PTO Rod	918196
2	Hitch Pin - all mowers	156306
2	Safety Clips - For Hitch Pins	176012

<u>QTY PER UNIT</u>	<u>DESCRIPTION</u>	<u>PART NUMBER</u>
1	39 amp. hr. Battery	1685063
1	Fuel Filter	173206
	Simplicity SAE5W-30 Cold Weather Engine Oil	1685518 (case of 12 qts.)
	Grease Gun Kit	1685510
	8 Oz. Tube - for above	103077
	**Touch-Up Paint Orange, Spray Can	103262
	**Touch-Up Paint White, Spray Can	103049

Pneumatic Tire Seal - Stops Leaks	
Available in following amounts:	
5½ Oz. Tube	1685522
11 Oz. Tube	1685523
Case of 24-5½ Oz. Tubes	1685524
Case of 24-11 Oz. Tubes	1685525
Split Case - 12-5½ Oz. Tubes and 12-11 Oz. Tubes	1685526

*Three required for 36" Mower

**Also available in 1/2 Oz. Brush Cap Daubbers

PARTS MANUAL AVAILABLE FOR 5100 SERIES

Simplicity Parts Manuals are fully illustrated. All of the assemblies are shown in exploded views which show the relationship of the parts and how they go together. Important assembly notes and special torque values are included in the illustrations. For standard hardware, a torque specification chart is included.

To order, enclose the form with a check or money order made out to SIMPLICITY. Address the envelope to:

Simplicity Manufacturing Co.
Attn: Cashier
500 N. Spring Street
Port Washington, WI 53074

Parts Manual TP-837 contains 5116 tractor with 36" & 42" Mowers.

Parts Manual TP-838 contains other major attachments and serviced accessories for 5116 tractor.

**Extend Equipment Life - Use Only Genuine
Simplicity Repair Parts**

- I would like parts manual (TP-837) for my 5100 Series tractor and mower. Enclosed is a check or money order for \$3.00.
- I would like parts manual (TP-838) for 5100 Series attachments. Enclosed is a check or money order for \$5.00.
- I would like both parts manuals listed above. Enclosed is a check or money order for \$8.00

Simplicity Manufacturing Company

Attn: Cashier

500 N. Spring Street

P.O. Box 210

Port Washington, WI 53074

(Print clearly this will be your mailing label)

NAME _____ Tractor _____
Mfg. No. _____

STREET OR RFD _____

CITY _____ STATE _____ ZIP _____





Simplicity Manufacturing, Inc.
500 N. Spring Street
P.O. Box 997
Port Washington, WI 53074-0997

Copyright © 1987 Simplicity Manufacturing, Inc.

PRINTED IN U.S.A.
