

These instructions cover dealer set-up of the following models of the SNAPPER Rear Engine Riders.

250815B	280915BE	301215BE	331415KVE
250815BE	300915BE	331415BVE	421615BVE
			421615TVE

Tools required for set-up are: HAMMER, PLIERS, 7/16" and 1/2" WRENCH or SOCKET.

A package of battery acid (electrolyte), purchased separately, is required for electric start models.

SNAPPER Series 15 Rear Engine Riding Mowers are shipped with steering components, seat & fuel tank detached to provide the lowest possible profile for shipment.

After uncrating, inspect the machine for damage, then proceed as follows to assemble and prepare the unit.

Open parts box and hardware bag and identify components shown on pages 4 & 5 (fig. 13 & 14). Note that not all parts in each bag are used on any one rider.

A. STEERING COMPONENTS

1. Steering Shaft

- Carefully stand Rider on rear bumper.
- Push steering shaft into place (see figure 2).
- Remove/discard vinyl cap from steering shaft end.
- Tap upper bushing so that it contacts control panel.
- Place thrust washer on top of bushing.
- Install 3/16" x 1-1/2" cotter-pin from parts bag into steering shaft above thrust washer.
- Install bushing cover over cotter-pin, thrust washer and bushing.
- Slide foam steering shaft cover over steering shaft. See Figure 1.

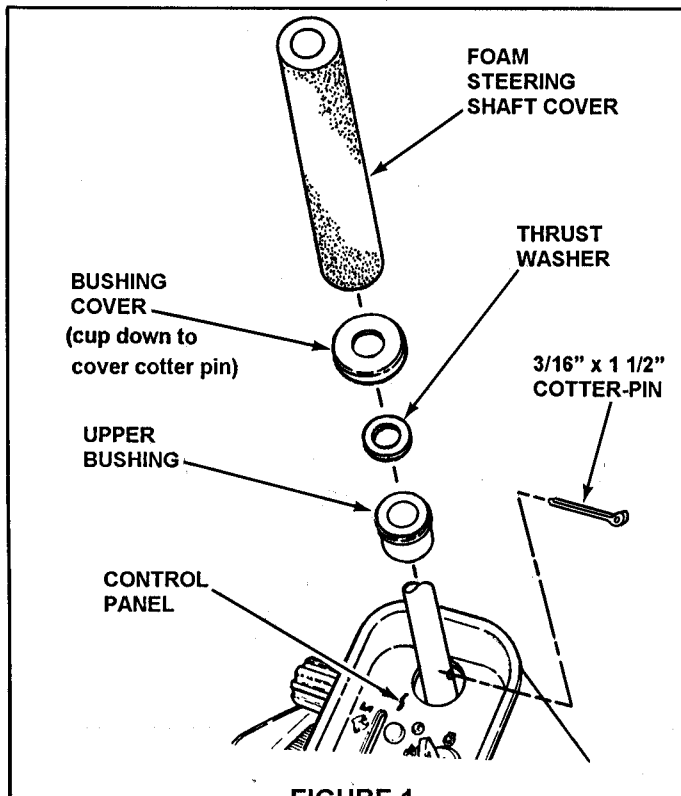

FIGURE 1

2. Installing Tie Rods - Narrow Front Frame (28" & smaller deck)

- Install bushings onto tie rods.
- Install tie rods into steering shaft. Secure with 3/8" flat washers and 5/32" x 1" cotter-pins. See Figure 2.

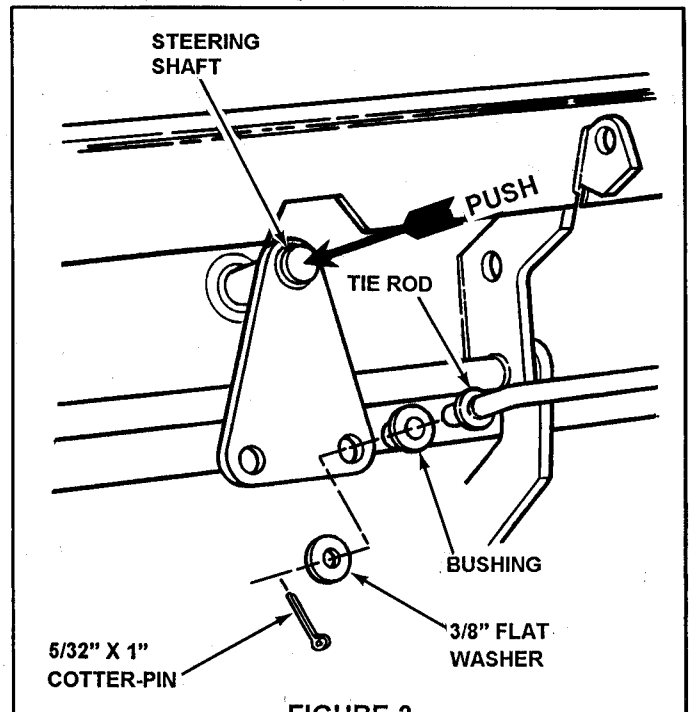

FIGURE 2

3. Installing Tie Rods - Wide Front Frame (30" & larger deck)

- Install tie rods, 5/16" lock washers and 5/16"-24 hex nuts. Tighten securely. See Figure 3.

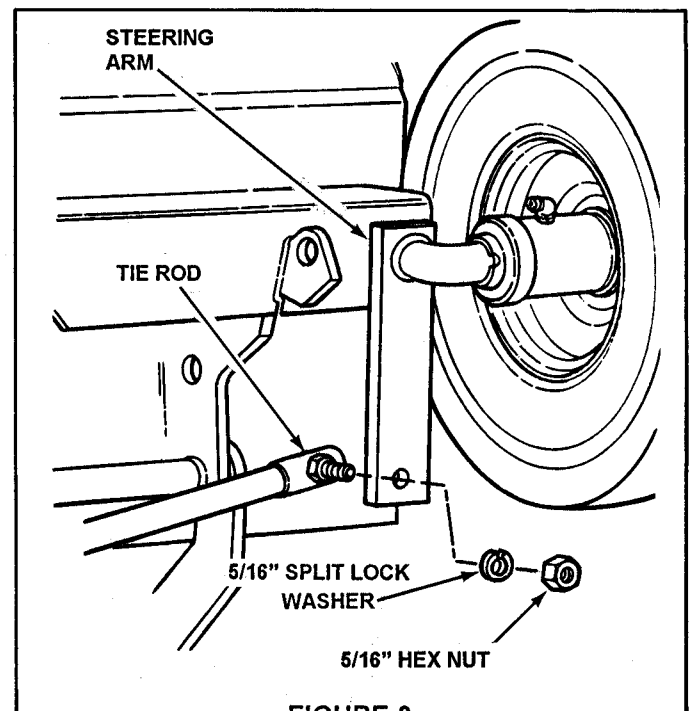

FIGURE 3

4. Installing Steering Wheel

- (a) Slide steering wheel on steering shaft. Normally, the offset of the steering wheel should be towards operator's seat.

NOTE: For more operator room, the steering wheel offset can be turned towards front of the Rear Engine Rider. The "SNAPPER" logo in the center of steering wheel can be snapped out and turned also.

- (b) Support steering wheel and drive the 1/4" x 1-1/2" roll pin into steering wheel and steering shaft. See Figure 4.

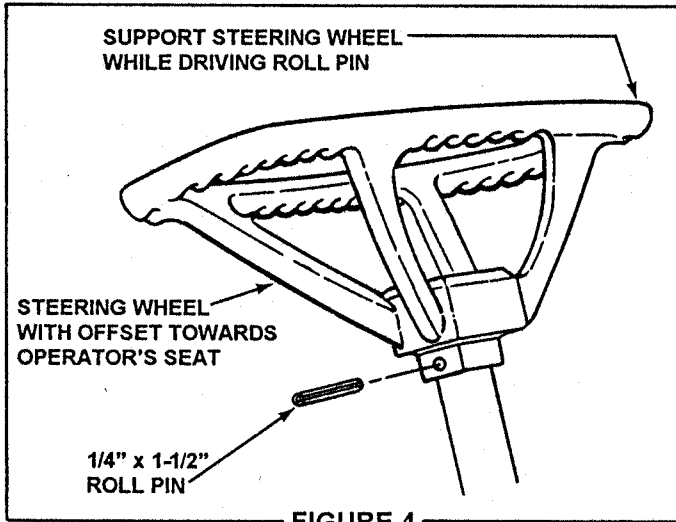

B. MOWING DECK

1. Cutting Blade

- (a) Check the torque of mowing blade mounting bolt. (35 to 55 ft. lbs. recommended)
- (b) Check the torque of air lift mounting bolts, equipped on 28" and 33" decks. (135 to 155 in. lbs. recommended)
- (c) Check blade straightness per operators manual.

C. LUBRICATION

1. Perform normal lubrication of the Rear Engine Rider. Check differential and chain case for proper lubricant levels. See Operator's manual.
2. After completing lubrication, carefully lower Rear Engine Rider to floor to continue set-up.

D. FUEL SYSTEM

1. Fuel Tank

Place fuel tank in bracket behind seat bracket and push tank down until it snaps into position. See figure 5.

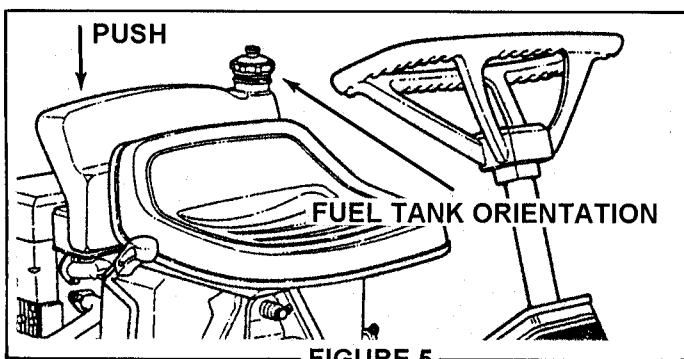

2. Fuel Line

Slide fuel line onto fuel tank hose barb and move hose clamp above end of the fuel tank hose barb (approximately 1/8" from end of hose). The fuel filter has been installed by the engine manufacturer. See Figure 6.

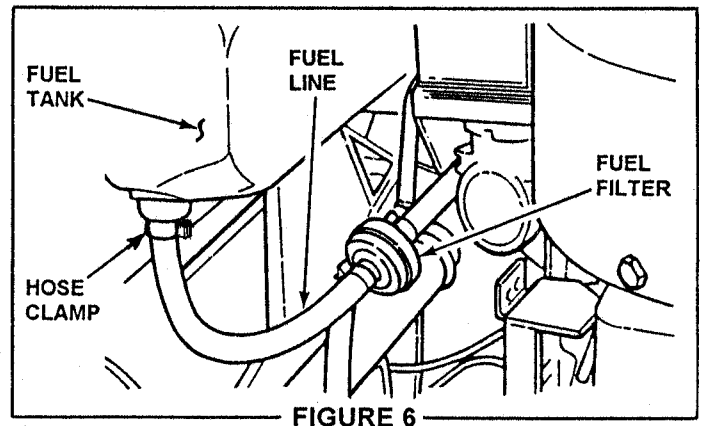

E. OPERATOR'S SEAT

[8 and 9HP Models]

1. Lay forward edge of seat onto seat pan.
2. Connect seat switch wiring harness to male tabs of seat switch (under seat). See Figure 7.
3. Position operator's seat onto seat bracket.
4. Install two 5/16-18 hex head flange patch lock screws into rear holes of seat.
5. Install two spacers onto the two adjusting knobs.
6. Install adjusting knobs through seat bracket and into the two front holes in operator's seat.
7. Adjust seat to desired position. Partially tighten rear screws, allowing seat to slide front to back. Tighten adjusting knobs to secure seat in position. See Figure 7.

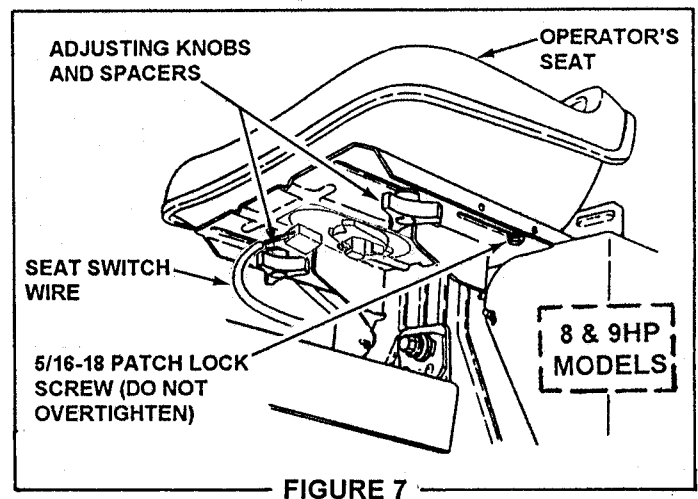

[12, 14 and 16HP Models]

1. Fold the hinged seat plate forward and follow steps 2 through 7 (above) for 8 & 9HP models. See Figure 8.

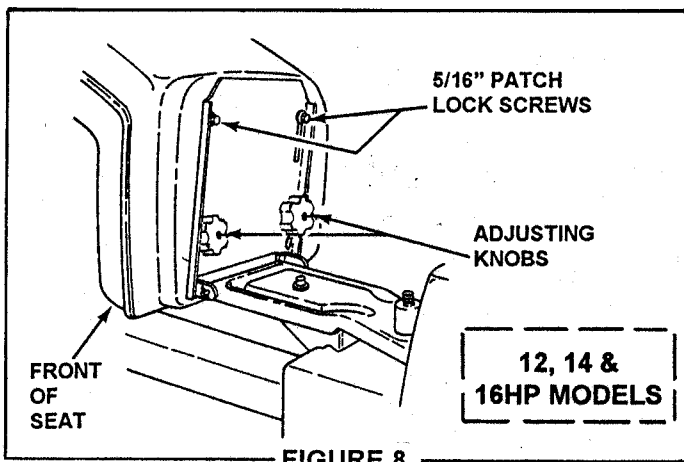

FIGURE 8

F. BATTERY

The battery for electric start models is shipped dry. It should be activated and charged according to the instructions enclosed with the battery. (See line 3 below for charging battery).

1. BATTERY REMOVAL

- Remove battery cover by pulling each side away from ratchet fasteners. See Figure 9.

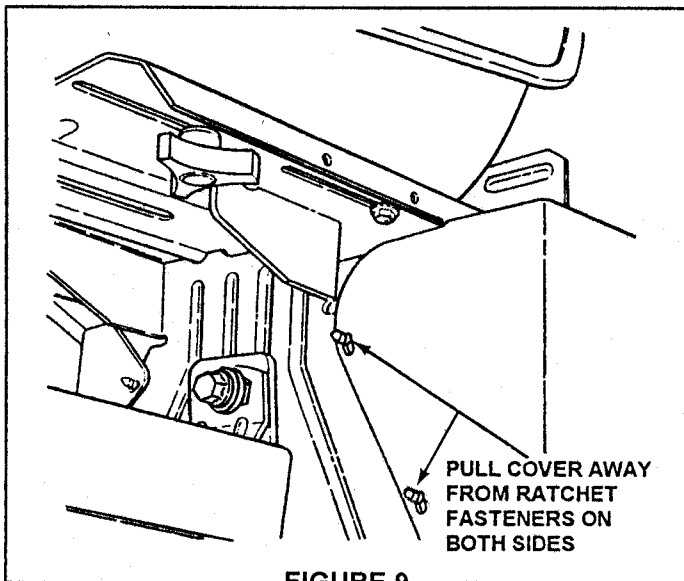

FIGURE 9

- Remove battery from battery box

2. BATTERY ACTIVATION

NOTE: For safety reasons the electrolyte (acid) for the battery is not supplied with the rider. Therefore the electrolyte must be purchased separately from your local dealer or retailer.

- Place battery in a well ventilated area on a level surface.
- Remove battery cell caps. Fill cells as required with electrolyte to between minimum and maximum fill line as viewed from outside battery case. Filling battery with electrolyte will bring the battery to 80% charged state.

NOTE: 3/16" above cell plates is the recommended level. However, do not try to measure this dimension. Never place anything in battery other than specified electrolyte.

CAUTION: DO NOT OVERFILL!

WARNING

THE ELECTROLYTE (ACID) PRODUCES A HIGHLY EXPLOSIVE GAS. KEEP ALL SPARKS, FLAME AND FIRE AWAY FROM AREA WHEN CHARGING BATTERY OR WHEN HANDLING ELECTROLYTE OR BATTERY. ELECTROLYTE (ACID) IS A HIGHLY CORROSIVE LIQUID. WEAR EYE PROTECTION. IN CASE OF EYE OR SKIN CONTACT WITH ELECTROLYTE (ACID), WASH ALL AFFECTED AREAS OF THE BODY IMMEDIATELY.

3. BATTERY CHARGING

- With all cell caps removed, connect an automotive type battery charger to battery terminals; RED to positive (+) and BLACK to negative (-) terminal.
- Slow charge at 2 to 6 amps for 30 minutes.
- After charging, check level of electrolyte, add electrolyte if necessary, and tighten cell caps.

4. BATTERY INSTALLATION

- Slide battery partially into box, with positive end to inside and terminals to rear, to allow for cable installations.
- Battery cables **MUST BE SECURED TO BATTERY TERMINALS** as shown in Figure 10, using the 1/4" screws and lock-nuts from the hardware bag.
- Place the positive (+) terminal insulator over positive terminal and cable. Refer to Figure 10.
- Slide battery into battery box and reinstall battery cover.

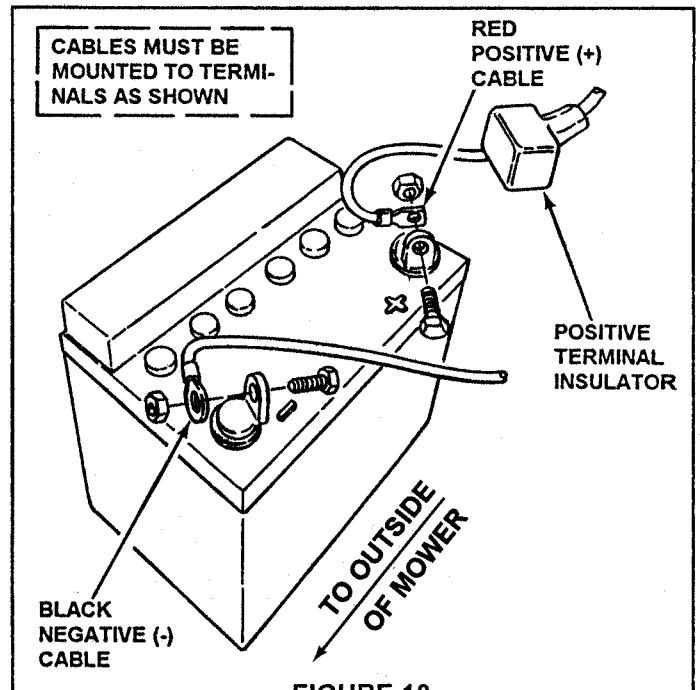

FIGURE 10

G. CHUTE DEFLECTOR

The chute deflector is shipped in the "UP" position. Remove rubber band, lower chute deflector and secure to deck with carriage bolt(s), flat washer(s) and wing-nut(s) furnished in the deck. See Figure 11.

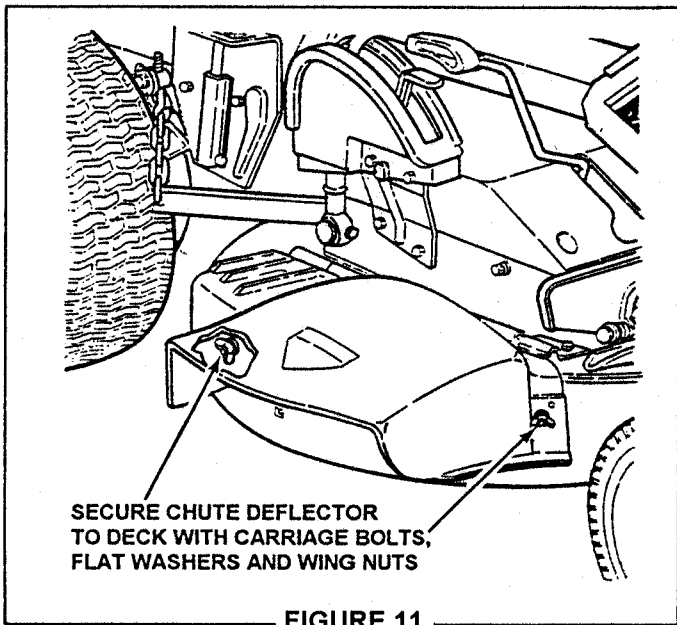

FIGURE 11

The parts box contains the following: gas tank, steering wheel, seat and hardware bag. The particular gas tank, seat and hardware bag depends on the model rear engine rider purchased. Replacement parts should be ordered individually.

I. ELECTRICAL CIRCUIT

The electrical connection at the engine is shipped disconnected to protect the electrical system when the battery is installed and **MUST BE THE LAST STEP** in preparation.

1. Connect electrical circuit at rear of the engine.
See Figure 12.

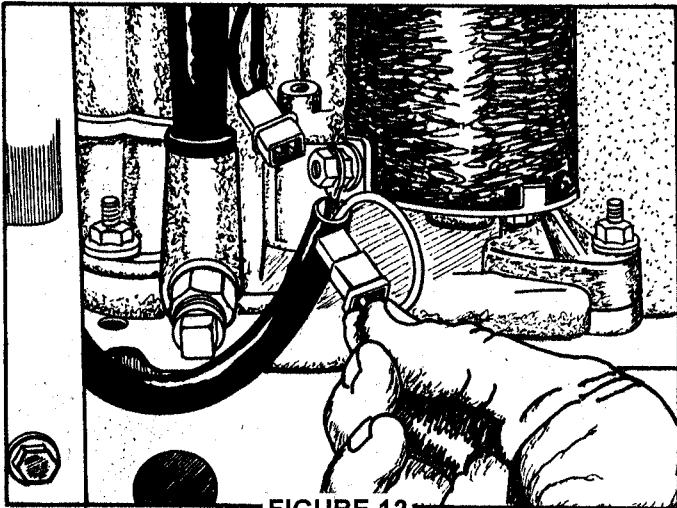
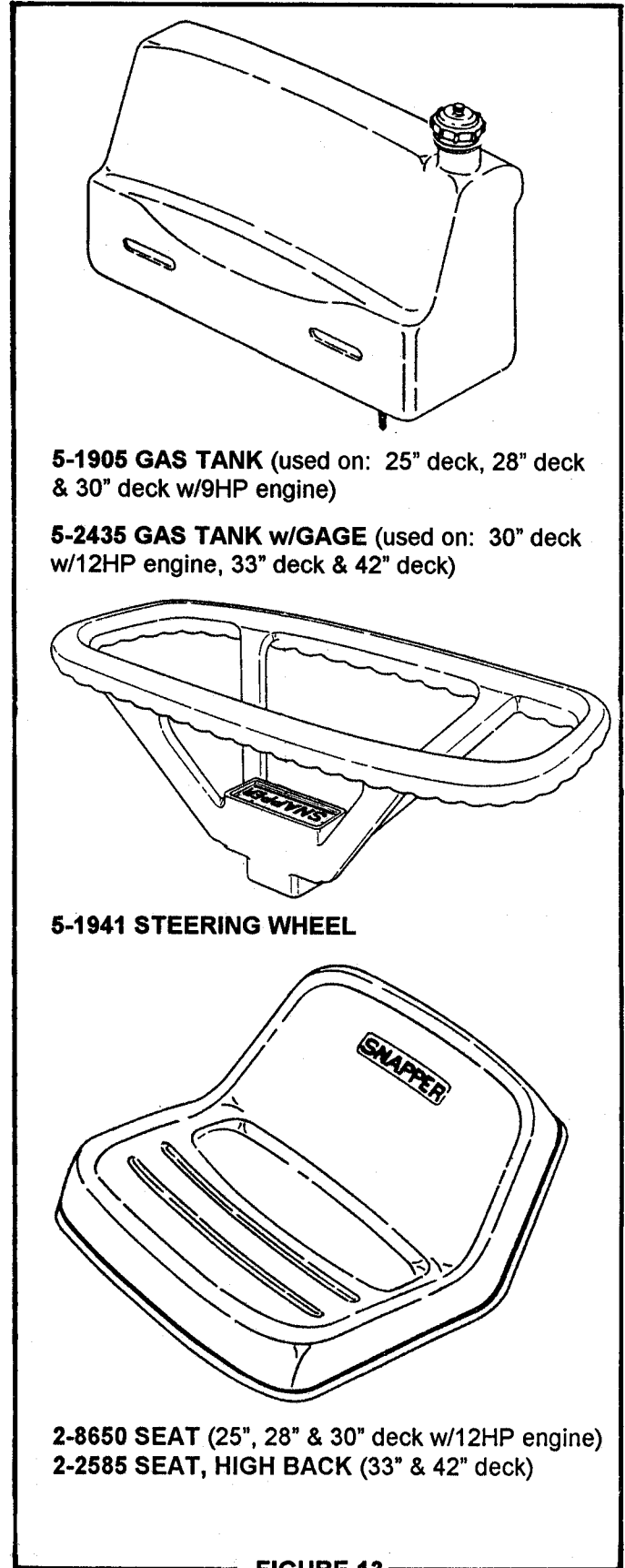

FIGURE 12



5-1905 GAS TANK (used on: 25" deck, 28" deck & 30" deck w/9HP engine)

5-2435 GAS TANK w/GAGE (used on: 30" deck w/12HP engine, 33" deck & 42" deck)

5-1941 STEERING WHEEL

2-8650 SEAT (25", 28" & 30" deck w/12HP engine)
2-2585 SEAT, HIGH BACK (33" & 42" deck)

FIGURE 13

I. ENGINE

Perform engine service, oil and fuel, according to engine manufacturer's recommendations.

J. PRE-SALE CHECK

Completely fill out the attached Pre-Sale Checklist **BEFORE** starting the engine, testing the Rear Engine Rider or delivering to the customer.

HARDWARE BAG 6-1401 (Models 250815B and 250815BE)

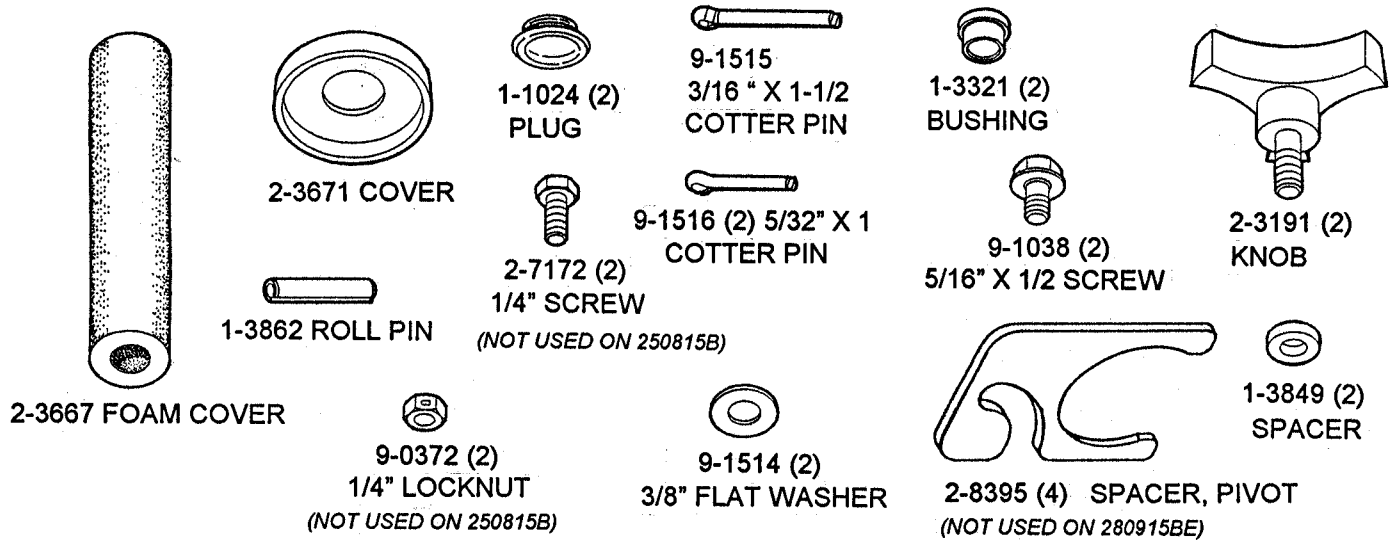

HARDWARE BAG 6-1840 (Model 280915BE)

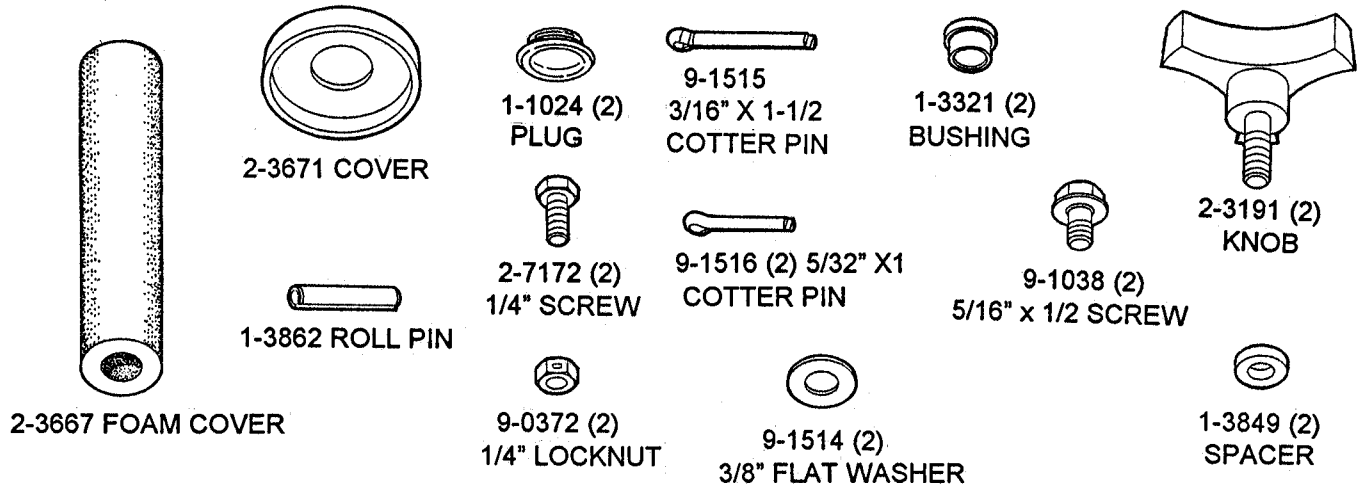

**HARDWARE BAG 6-1792 (Models 300915BE, 301215BE, 331415BVE,
331415KVE, 421615BVE and 421615TVE)**

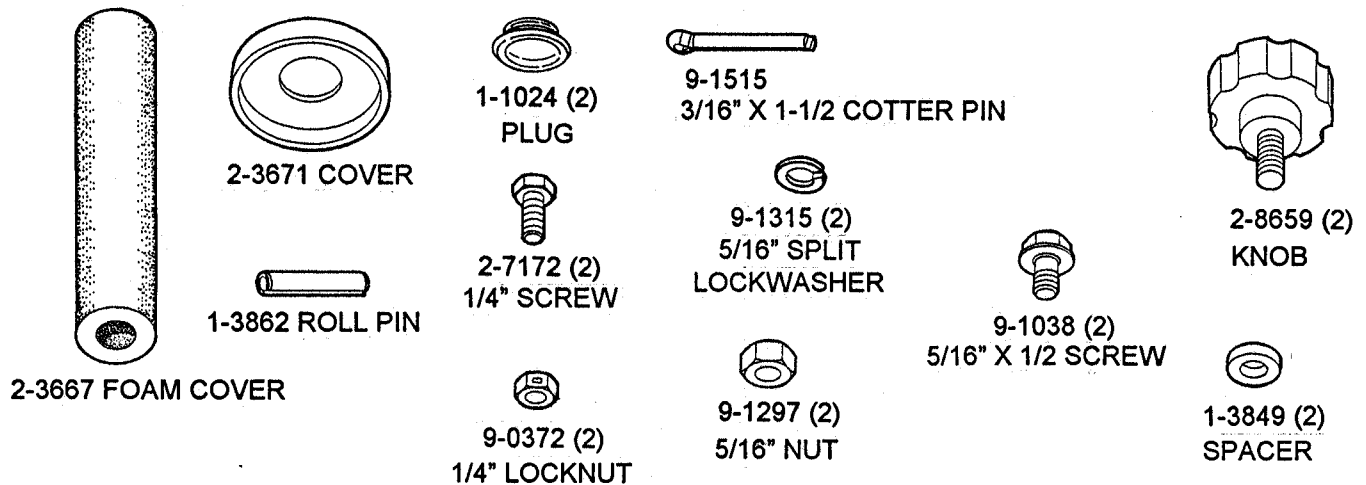

FIGURE 14

DEALER PRE-SALE CHECKLIST

SET-UP CHECKLIST

- STEERING wheel and steering shaft assembled.
- TIE RODS connected.
- LUBRICATION of entire unit completed.
- OPERATOR'S SEAT installed and tightened.
- FUEL TANK installed and fuel line connected.
- GRASS DEFLECTOR, MULCH COVER or BAGGER BOOT & ASS'Y positioned, secured, checked.
- BATTERY activated and charged per battery instructions.
- BATTERY installed.
- TIRES inflated to proper psi. Front 15 psi, rear 10 psi.

Refer to Operator's Manual or Service Manual for Specific Torque Values not Contained in this Checklist.

CUTTING BLADE & DECK CHECKS

- BLADE RETAINING bolts at proper torque value. Torque from 35 to 55 ft. lbs.
- AIR LIFT bolts tight. Torque from 135 to 155 in. lbs.
- BLADE ALIGNMENT checked for equal tracking and adjusted as needed.
- BLADE STRAIGHTNESS checked and adjusted as required.
- DECK CUTTING HEIGHT SETTINGS checked and adjusted as needed.
- DECK SIDE-TO-SIDE LEVELNESS checked and adjusted as required.
- DECK FRONT-TO-REAR LEVELNESS checked and adjusted.
- BLADE LEVER checked and adjusted as required.
- BELT TENSION checked and adjusted as required.

PRE-START CHECKS & SERVICES

- ENGINE OIL - Refer to Engine Owner's Manual for proper oil specifications.
- DIFFERENTIAL - Check lubricant and add as needed.
- CHAIN CASE - Check lubricant and add as needed.
- YOKE LIFT - Lubricate all pivot points and check for freedom of movement.
- FUEL - Add fuel to tank and check system for leaks. Refer to Engine Owner's Manual for fuel specifications.

OPERATIONAL TEST

- INTERLOCK system checked for proper functioning.
- ENGINE started. Throttle control settings checked and adjusted as needed.
- IGNITION SWITCH checked to insure operation in all positions.
- PARKING BRAKE tested and adjusted as required.
- CLUTCH/BRAKE tested for proper operation and adjusted as required.

AUTOMATIC BLADE STOP TESTS

- BLADE stops no later than 3 seconds after blade pedal is released. Adjust blade brake as required.*
- BLADE LEVER can be moved to "OFF" with BLADE PEDAL depressed.

DEMONSTRATION & INSTRUCTION

- PERSONALLY HANDED Operator's Manual and Mower Safety Booklet to owner.
- INSTRUCTED owner to read and follow instructions in Operator's Manual.
- DEMONSTRATED proper operation of unit to owner.
- AIR CLEANER SERVICE and ENGINE OIL CHECK procedure explained to owner.
- ASSISTED purchaser in completing Product Registration Card.

*per Operator's Manual/Safety Instruction 28603

DEALER'S RECORDS

Sale Date _____ Model _____ Serial No. _____

Dealer's Name _____ Signature _____

Address _____ City _____ State _____ Zip _____

MOWER WILL BE USED COMMERCIALY? YES _____ NO _____

Purchaser's Name _____ Signature _____

Address _____ City _____ State _____ Zip _____

IMPORTANT: This form is to be detached from booklet and retained by the Dealer for future reference regarding Warranty, proof of purchase, traceability and product recall or service, etc.