

Safety Instructions & Operator's Manual for

SNAPPER[®]

41085, 41085S SERIES

- **AUTOMATIC BLADE STOP**
- **SMOOTH START CLUTCH**



RIDING MOWERS

THANK YOU for buying a SNAPPER product. Before operating your mower, read and follow the important Safety Instructions, the other instructions contained in this manual and the accompanying pamphlet, "About Power Mower Safety". Lawnmowers, and all power equipment, can be potentially dangerous if used improperly. This mower has the new Automatic Blade Stop and Smooth Start Clutch. These features are designed to provide some additional protection for people who operate the mower, however, serious injuries can still occur. REMEMBER: SAFETY REQUIRES CAREFUL USE IN ACCORDANCE WITH INSTRUCTIONS, AND COMMON SENSE.

IMPORTANT SAFETY INSTRUCTIONS

WARNING: This powerful cutting machine is capable of amputating hands and feet and can throw objects that can cause injury and damage! Failure to observe the following safety instructions could result in serious injury. Carefully read this manual and question your dealer if something is not clear. Should the dealer be unable to answer to your satisfaction, write or call the Customer Service Department at SNAPPER Power Equipment, McDonough, Georgia 30253 (phone 404-957-9141).

PROTECTION FOR CHILDREN

1. DO NOT allow children in yard when mower is operated.
2. DO NOT allow children to ride on mower or attachments.
3. DO NOT ALLOW pre-teenage children to operate mower.
4. Only responsible teenagers with mature judgement shall be allowed to operate mower and only under close supervision.

PROTECTION AGAINST TIPOVERS

1. DO NOT operate mower on slopes exceeding 15° (27% grade).
2. On slopes above 10° (18% grade); exercise extreme caution; turn blade OFF when traveling uphill; do not mow across; reduce speed to No. 1 position, avoid sharp turns and uphill starting.
3. AVOID UPHILL STARTS. If machine is stopped going up slope, turn blade off and back slowly down slope.
4. DO NOT mow under any condition where traction or stability is doubtful without first test driving over terrain with blade OFF.
5. Stay alert for holes and other hidden hazards and keep away from ditches, washouts, culverts, fences and protruding objects.
6. Always begin forward motion in No. 1 speed position.
7. Use weighted load carrier on front when using grass catcher on slopes.

OTHER IMPORTANT PRECAUTIONS

1. Read and follow operator's manuals and instructions furnished with attachments.
2. Only mature, responsible persons shall operate the mower.
3. Mount and dismount mower from left side.
4. Wear appropriate protective clothing when mowing such as substantial footwear and long pants, not barefoot or with open sandals.
5. Practice operation of mower with blade OFF to learn controls and develop skill.
6. Persons under the influence of alcohol or drugs must not operate mower.
7. Know how to stop blade and engine quickly in preparation for emergencies.
8. Keep people and pets a safe distance from mower.
9. Shields, deflectors, switches, blade controls and other safety devices must be in proper position and functional.

10. Clear area to be mowed of wire, rocks and other objects that could cause injury if thrown by blade.
11. Shift blade OFF and transmission into NEU/PARK before starting or whenever leaving mower momentarily. Also, remove key when leaving mower unattended.
12. DO NOT operate mower unless properly seated with feet on pads or pedals.
13. Keep hands and feet away from rotating blade underneath deck. Never place foot on ground while blade is ON or when mower is in motion!
14. Turn blade OFF, stop engine and wait for blade to stop before attempting to unclog grass or leaves to prevent loss of fingers or hand.
15. Blade must be shifted OFF except when cutting grass. Set cutter in highest position when mowing over rough ground.
16. Deflector or grass catcher must be in position. Never point discharge at people, passing cars, windows or doors. Watch out for traffic when crossing or near roadways.
17. Mow in reverse only after careful observation of entire area behind the mower. DO NOT mow in reverse unless absolutely necessary.
18. Service mower and make adjustments only when engine is stopped.
19. Have mower serviced by an authorized Snapper dealer at least once a year and have the dealer install any new safety devices.
20. Use only genuine Snapper replacement parts to assure that original standards are maintained.
21. Tighten all nuts, bolts and screws frequently and check, adjust, repair or replace brakes as needed.
22. Lubricate mower at intervals specified in manual to prevent controls from binding.
23. Use the auxiliary brake pedal on right to prevent mower from rolling backward as the clutch-brake pedal is released when starting out on slopes. NOTE: Auxiliary brake alone will not stop mower.
24. Mow only in daylight or in good artificial light.
25. Handle gasoline with care! Never remove cap while engine is running. Fill tank outdoors only with engine stopped and cool. Clean spilled gasoline from machine. Store gasoline in approved container, out of the reach of children, in well ventilated, unoccupied building.
26. DO NOT run engine indoors. Exhaust fumes are dangerous.
27. DO NOT change engine governor speed settings or overspeed engine.
28. Check grass catcher components frequently for signs of wear or deterioration and replace as needed to prevent injury from items going through weak or worn spots.
29. Exercise caution when pulling loads. Limit loads to those you can safely control and attach loads to hitch plate as specified with Snapper attachment instructions.

OPERATING INSTRUCTIONS

INTRODUCTION

This manual covers Snapper model 41085 Series automatic blade stop, smooth start clutch, equipped, rear-engine Riding Mowers. In addition to the operation instructions, it includes routine service and adjustment recommendations.

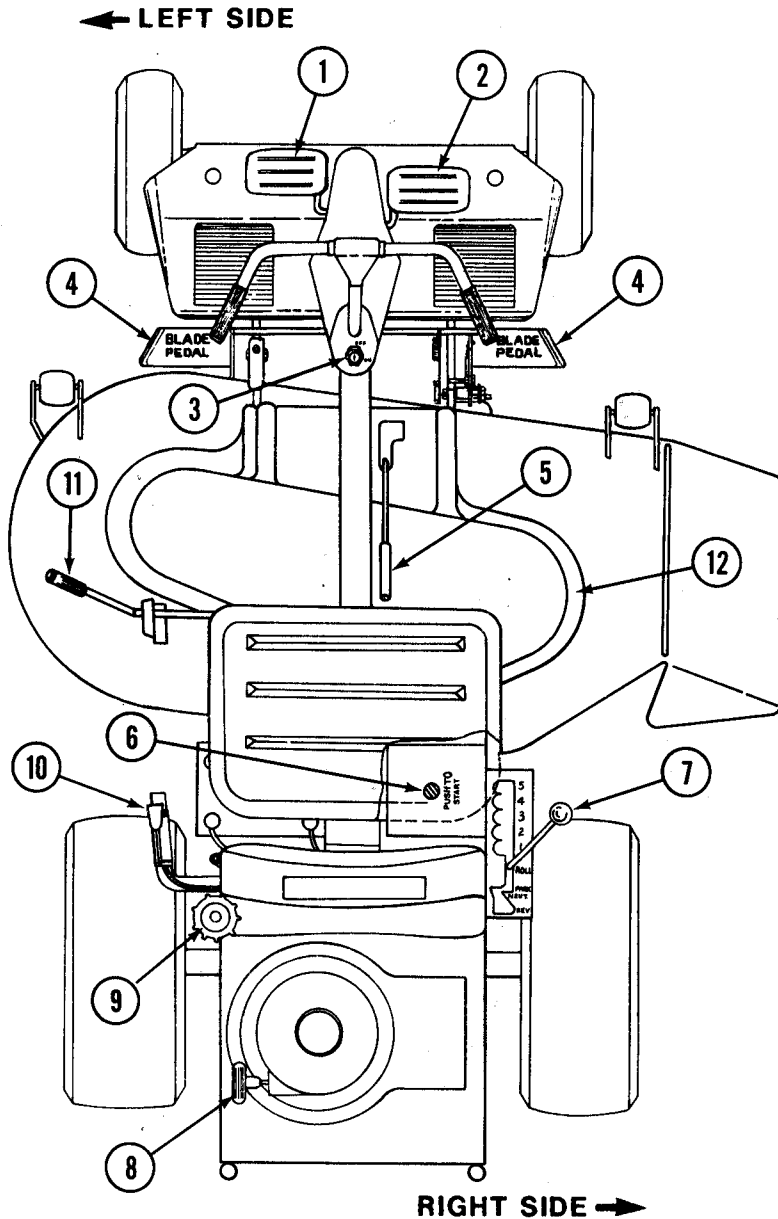

1. CLUTCH/BRAKE PEDAL
2. AUXILIARY BRAKE PEDAL
3. ENGINE IGNITION KEYSWITCH
4. BLADE (STOP) PEDAL
5. CUTTER BLADE ON—OFF LEVER
6. PUSH BUTTON (ELECTRIC START)
7. TRANSMISSION SHIFT LEVER
8. ROPE STARTER HANDLE
9. FUEL FILLER CAP
10. ENGINE (SPEED) CONTROL
11. CUTTING HEIGHT LEVER
12. BELT COVER (GUARD)

FIG. 1 — LOCATION OF CONTROLS

PRE-START PROCEDURE

Before each start-up, check and/or perform the following:

1. CHECK TIRES for proper inflation and add air as needed to bring pressure up to specification (see figure 2). A low tire not only causes uneven mowing but is more subject to rim leakage upon impact with curbing etc.
2. CHECK GUARDS & COVERS to make sure all are properly installed and securely tightened.
3. CHECK BLADE CONTROLS to make sure they work freely and that BLADE LEVER snaps from ON to OFF when BLADE PEDAL is released.
4. CHECK EXTERIOR SURFACES and clean up any accumulation of grass, oil, dirt etc., especially around air intake and cooling fins on engine.
5. CHECK ENGINE OIL and add oil as needed to bring up to (but not over) the Full mark. Refer to engine manual for oil specifications.
6. FILL FUEL TANK after pushing mower outdoors where fumes will be dissipated. Refer to engine manual for fuel specifications. Reinstall and tighten filler cap after filling tank.

STARTING-STOPPING ENGINE

The engine is stopped by either turning the ENGINE IGNITION keyswitch OFF or by moving the ENGINE CONTROL rearward to STOP. Refer to figure 1 for location of these and other CONTROLS. Start the engine as follows:

1. FUEL: Turn valve on fuel filler cap counter-clockwise to open.
2. TRANSMISSION & CUTTER: Depress CLUTCH/BRAKE pedal and shift transmission to NEU/PARK, shift CUTTER ON-OFF lever to OFF. Note: interlocks will prevent engine starting unless this is done.
3. CHOKE engine for cold starting by moving ENGINE CONTROL to CHOKE position.
4. IGNITION: Insert key in ENGINE IGNITION switch and turn ON.
5. START manually by pulling rope starter until engine runs. For electric start,* push starter button down and hold (not more than 5 seconds each time) until engine runs. As the engine warms up, move the ENGINE CONTROL out of choke into the desired speed setting.

*NOTE: Electric start engines feature battery charging alternators. If the battery is too weak to start electrically, use the rope starter method then run the engine for about an hour to recharge the battery.

STARTING-STOPPING MOTION

Become thoroughly familiar with location of the forward/reverse motion controls (see figure 1) and the function of each before operating the cutter. To stop motion, depress the CLUTCH/BRAKE pedal! The other motion controls are the transmission SHIFT LEVER and the AUX. BRAKE (auxiliary) pedal. Operate as follows after engine has been started:

1(A). FORWARD MOTION—UPHILL: Depress both pedals and release the CLUTCH/BRAKE pedal **before** releasing the AUX/BRAKE pedal. This prevents the Rider from rolling backward on inclined surface as the clutch brake pedal is released. **CAUTION:** Depressing the AUX/BRAKE pedal will not stop motion of the Rider when operating under engine power.

1(B). FORWARD MOTION—LEVEL SURFACE: Depress CLUTCH/BRAKE pedal part way down, shift TRANSMISSION LEVER to #1 speed position, then slowly release CLUTCH/BRAKE pedal. The Rider can be shifted into the higher, 2 thru 5, speeds on the go without depressing the CLUTCH/BRAKE pedal. Push the CLUTCH/BRAKE pedal all the way down to stop forward or rearward motion.

As a safety precaution when stops and starts must be made on steep inclines, turn cutter OFF, depress both foot pedals, shift transmission into No. 1 speed position, idle engine speed then slowly release clutch/brake pedal first and release the auxiliary brake pedal as the mower starts to move forward. Remember that weighted load carrier must be used with rear mounted grass catcher when on slopes. See accessories on back page.

REVERSE MOTION: Depress the CLUTCH/BRAKE pedal to stop forward motion then release this pedal part way and shift transmission to REV (reverse) then slowly release CLUTCH/BRAKE pedal all the way. **NOTE:** hold transmission shift lever firmly in REV position while backing up! If the shift lever is released while backing up, the driven disc may be damaged from contact with the parking brake mechanism. To Stop the reverse motion, depress the CLUTCH/BRAKE pedal. The transmission should shift out of reverse into neutral when the CLUTCH/BRAKE pedal is depressed.

PARKING/ROLLING MACHINE: Shifting the transmission into the NEU/PARK position locks the transmission and prevents the machine from rolling forward or backward. To roll the machine with engine off, shift transmission into ROLL position and push machine. Always park machine with transmission shifted into NEU/PARK. The transmission may be shifted from NEU/PARK TO ROLL and from ROLL to NEU/PARK without depressing clutch/brake pedal.

STARTING-STOPPING CUTTER BLADE

The automatic blade stop controls on this mower are provided to stop cutter blade rotation in less than 3 seconds after the BLADE PEDAL is released. Two separate and deliberate actions are required of the operator to start and keep the blade turning. Note that the BLADE lever (see figure 1) is blocked from forward movement if the BLADE PEDAL is depressed--the BLADE LEVER must therefore be shifted forward before the BLADE PEDAL is depressed. Start and Stop the cutter blade as follows:

1. Shift BLADE LEVER forward to ON and hold then push the BLADE PEDAL down. Keep your heel (or heels) on the blade pedal to lock the blade ON to continue mowing. **NOTE:** The blade will rotate whenever the BLADE LEVER is ON.
2. Stop blade rotation by removing heel (or heels) from BLADE PEDAL which allows the spring loaded BLADE LEVER to snap rearward to OFF. The BLADE LEVER can be forced OFF even with the BLADE PEDAL depressed by pushing the lever inward then pulling rearward to OFF.
NOTE: If the blade lever moves slowly rearward rather than snapping back as it should when the blade pedal is released, the cutter belt may be too slack. To correct tension of the belt, stop the engine, shift the transmission to NEU/PARK, set the cutter in #5 cutting height position, then follow instructions for BELT TENSION adjustment later in this manual.

SERVICE

SERVICE ASSISTANCE - REPLACEMENT PARTS

To retain the quality of your mower, use Genuine Snapper Replacement Parts only. Contact your local Snapper dealer for parts and service assistance. For the correct part or information for your particular mower, always mention model and serial number. We recommend returning your mower to an authorized Snapper Dealer on a yearly basis for inspection and addition of any new devices which might upgrade the safety of your mower. For the nearest Snapper Dealer, check the yellow pages under the heading LAWN MOWERS. For engine parts and service, look for the engine manufacturer's dealers under the heading ENGINES-gasoline.

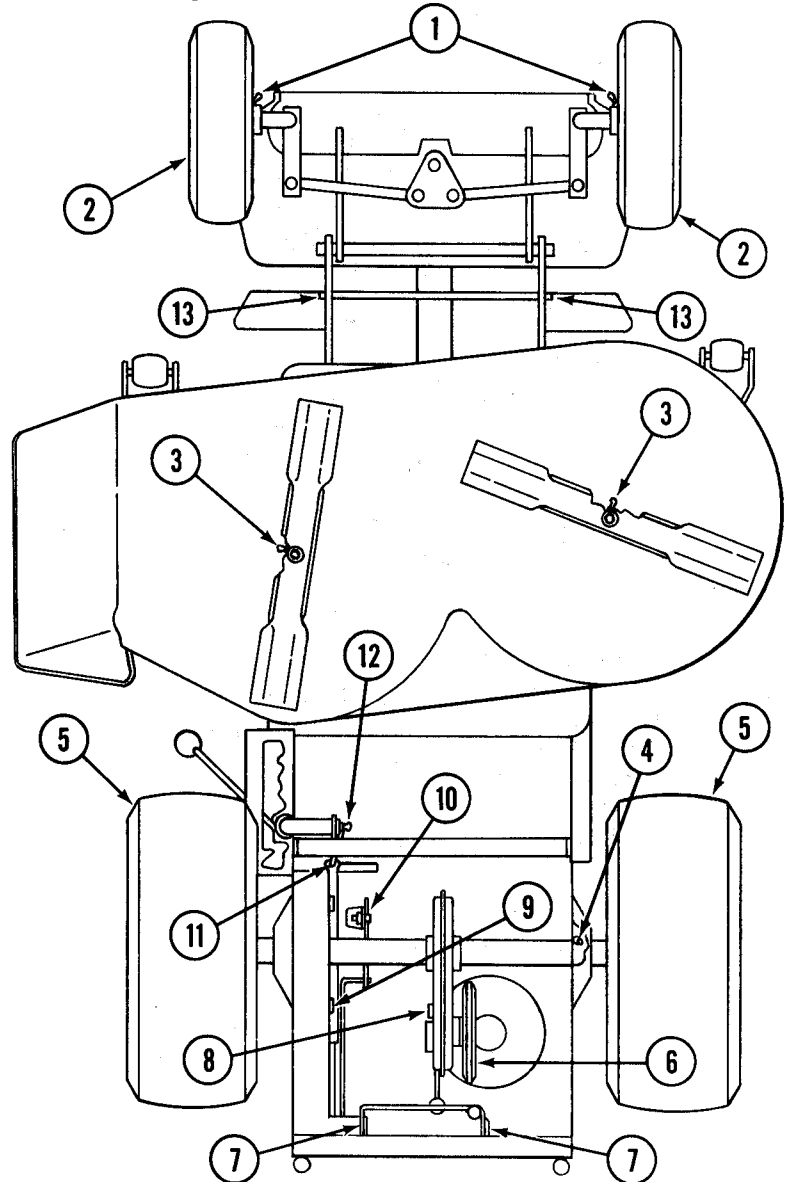

1. FRONT WHEEL BEARINGS
2. FRONT TIRES - 20 PSI
3. BLADE SPINDLE FITTING
4. LEFT REAR AXLE FITTING
5. REAR TIRES - 12 PSI
6. DRIVEN DISC
7. YOKE PIVOT POINTS
8. CHAIN CASE CHECK PLUG
9. DIFFERENTIAL CHECK PLUG
10. CLUTCH ROD & GUIDE
11. SHIFT ARM PIVOT POINTS
12. SHIFT LEVER FITTING
13. BLADE PEDAL PIVOT POINTS

FIG. 2 — LUBRICATION & SERVICE POINTS

All Snapper rear-engine riding mowers can be stood on their back bumpers for servicing provided the following steps are taken beforehand. The fuel filler cap on the tank must be tight to prevent leakage and the valve on top of the cap must be turned closed. Snapper low-maintenance batteries on electric start models are designed so that they will not spill acid when the mower is stood on end, provided the fluid level in each cell covers each plate but is no higher than the bottom of the fill ring. Remove the battery to prevent damage to battery if the unit is to be stood on end more than two hours.

LUBRICATION SCHEDULE

EVERY 25 OPERATING HOURS

- **FRONT WHEEL BEARINGS:** On new machine, lubricate through fittings with 10 shots of bearing grease from a pressure gun after the first 25 hours operation and thereafter with 2 shots every 25 hours.
- **REAR LEFT AXLE BEARING:** Lubricate through fitting with 2 shots of bearing grease from a pressure gun. Right hand bearing is lubricated by transmission.
- **ENGINE:** Change lube oil following recommendations stated in engine manual.

TWICE YEARLY

- **SHIFT LEVER:** Lubricate through fitting located inside case on end of mechanism with 2 shots of grease from pressure gun.
- **CUTTING HEIGHT LEVER:** Remove belt cover from deck and apply small amount of medium grade cup grease to top surface of adjusting cams on both sides. Before replacing cover, lubricate idler arm as follows:
- **BLADE ENGAGEMENT LEVER:** Lubricate idler arm and engagement lever at each wear point with a few drops of oil.
- **BLADE PEDAL:** Lubricate all pivoting and sliding surfaces where motion occurs when the pedals are moved with a few drops of oil. Reinstall spindle cover after lubricating blade lever and pedals.

END OF SEASON:

- **BLADE SPINDLE:** Two shots of grease only once yearly.
- **DIFFERENTIAL:** After standing mower on rear bumpers, remove plug from differential housing and check level of grease. Add Snapper 00 grease as needed to bring level up to bottom edge of hole. Install new plug after servicing.
- **CHAIN CASE:** With mower standing on end, remove plug and check. Add 1 ounce of Snapper 00 grease to case if needed. Avoid overfilling - total capacity must not exceed 2 ounces. Install new plug after servicing.

CUTTING BLADE SERVICE

Before doing any work on blade, remember to disconnect the spark plug wire and secure it away from plug to prevent unintentional starting. Have blade replaced if it becomes bent or chipped from impacting solid objects or when the cutting surface becomes dull from extended use.

Check the blade retaining bolts at frequent intervals to make sure blade is tight. These must be tightened to 20-30 foot pounds torque value.

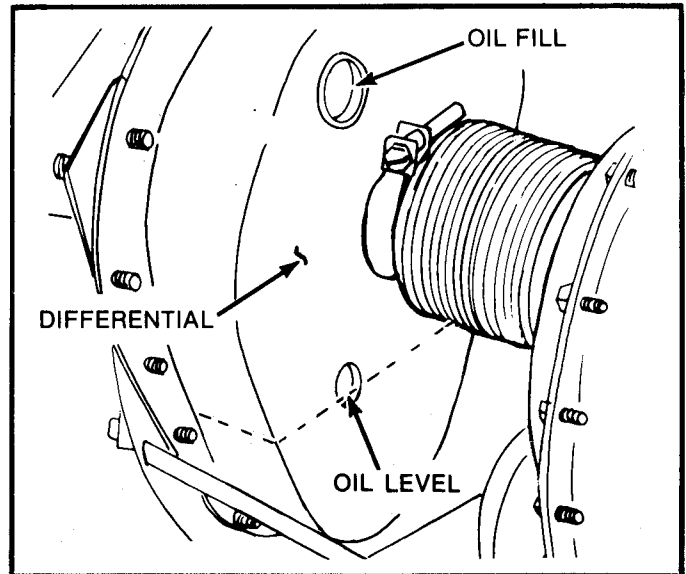

FIG. 3 — DIFFERENTIAL LUBE LEVEL

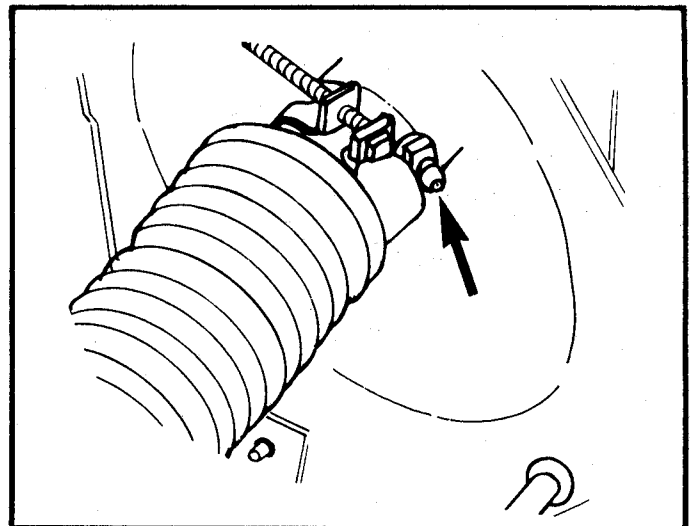

FIG. 4 — REAR AXLE LUBE POINT

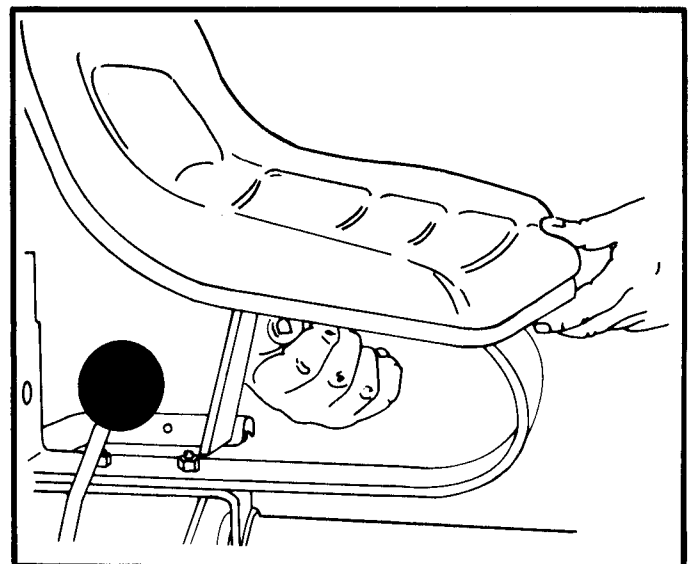

FIG. 5 — CHECK SEAT RETAINER SCREW

CUTTING DECK SERVICE

If the mower skips over the lawn leaving uncut areas, this could be caused by travelling too fast for the grass conditions with the engine speed set too low, or belt slippage or the cutting deck being improperly set from front to rear. An uneven cut from one side of the swath to the other is usually caused by uneven tire pressure although it may also be caused when the deck is not level from side to side. If a bad cutting pattern develops and the cause is not belt slippage or uneven tire pressure, move the Rider to a flat, level surface such as your garage floor and check the cutting deck settings with engine stopped as follows:

SIDE TO SIDE ADJUSTMENT: Raise the deck and place a piece of angle iron or similar triangular shaped block under the rear center of the deck then lower the deck onto the block. Set the blades perpendicular to the main tube and measure from the floor to the outside cutting tip of the blades. The deck is considered level from side-to-side if both measurements are the same within $1/8"$. The side-to-side adjusting knuckle which is located on the left front lift arm of the mower must be adjusted if the measurements differ by more than $1/8"$. To adjust, loosen the capscrew on the side of the knuckle and the jam-nut then turn the square head setscrew clockwise to raise the left side or counterclockwise to raise the right side. When level within $1/8"$, hold the setscrew and tighten the jamnut then tighten the capscrew tight to lock at new setting. Remove the block and check rear chains. If one of the chains is slack, adjust eyebolt until both chains have equal tension, then recheck for level.

FRONT TO REAR ADJUSTMENT: On 41" mowers, align the blade on the discharge side parallel to the main tube and measure the distance from the front cutting tip to the ground. Rotate that cutting tip to the rear and remeasure. The 41" mowers should measure $1/4"$ higher at the rear. To adjust, turn both rear chain hooks the same number of turns to raise or lower the rear of the deck.

NOTE: If poor mowing pattern continues after correcting the side to side and front to rear levels, the problem may be a misaligned deck spindle - return your mower to a Snapper Dealer to have the spindle aligned.

CLUTCH ADJUSTMENTS

The clutch is initially set for smooth action under normal load conditions. It can be readjusted to be more aggressive, for example, to pull heavy loads. Adjustment is made by repositioning the yoke lift spring. Initially the spring is hooked in the middle hole of the guide link. To make it more aggressive, increase spring tension by reconnecting to the top hole of the guide link. To make it less aggressive, reconnect the spring to the bottom hole of the link.

OPERATOR'S SEAT

Check and retighten the cap screw on underside of seat at frequent intervals to assure that the seat remains securely attached to the seat spring. Do not operate rider if seat wobbles even slightly! The operator's seat can be moved forward or backward by repositioning the retaining cap screw in either of the three holes provided in the seat spring. After repositioning, make sure seat retaining cap screw is securely tightened (50-75 foot pounds specified).

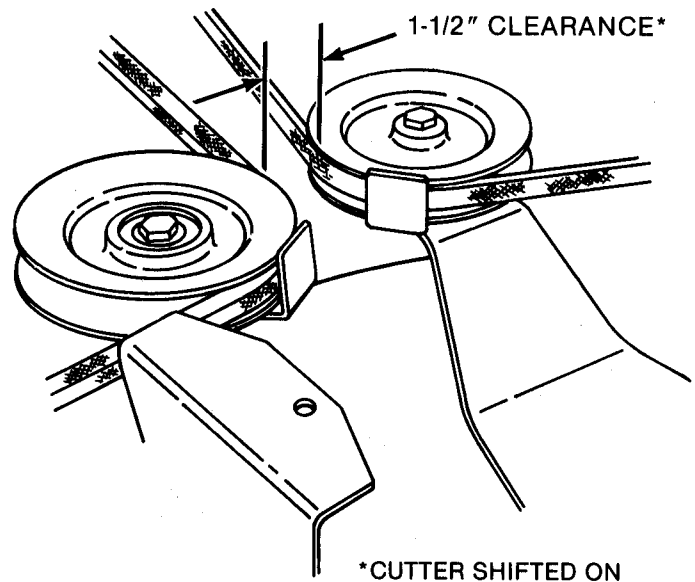

FIG. 6 - 41" MOWER BELT TENSION

FUEL FILTER

An in-line fuel filter is provided between the fuel tank and carburetor to protect the engine against damage from impurities in the gasoline. Check this occasionally for leakage especially around the hose clamp areas. Replace the see-thru filter (Snapper #1-4359) before the screen becomes totally clogged with sediment. Make sure the replacement filter is installed with side marked IN toward tank and OUT toward carburetor.

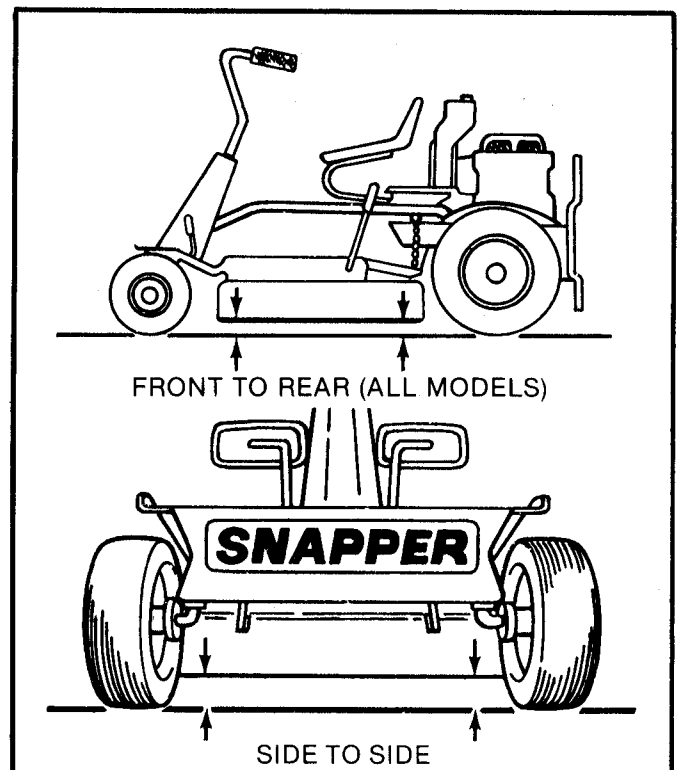

FIG. 7 - CUTTING DECK SETTINGS

BELT TENSION ADJUSTMENT AND REPLACEMENT

With the engine off and deck in the lowest cutting height and the cutter shifted into engaged position, check the distance between the inside span of the belt and the closest edge of the idler pulley - when properly tensioned, this should measure about 1-1/2" as shown in figure 6. Belt tension is adjusted by changing the distance between the front axle and rear case assemblies. This is accomplished by loosening the main tube clamp (under the seat spring) and pulling the front assembly away to increase tension or pushing it in closer to decrease tension on the drive belt. When proper tension is achieved, retighten the main tube clamp. If distance changed considerably, check and readjust the brake control cables if needed after repositioning front end assembly.

Replace belt if badly worn, cracked or frayed. Use the following procedure to install new belt: Remove belt top cover, cut and remove old belt, then loosen belt restrictors and push away from pulley enough to allow installation of new belt. Loop belt around pulleys and belt restrictors as shown in figure 6. Check and readjust belt tension if required. Reinstall belt top cover.

BLADE BRAKE ADJUSTMENT

The blade brake compensates for wear. As the brake band wears, the blade control lever will gradually stop further rearward in the slot of the cover. Adjustment is required when the lever touches rear of slot (figure 8) or when the blade takes more than 3 seconds to stop. A 7/16" wrench is needed for this procedure. The adjusting point is shown in figure 9. The adjustment is made with the engine stopped as follows.

STEP 1: Lower cutting deck and remove two screws securing the top cover of the belt guard and remove top cover.

STEP 2: While holding the blade lever firmly in the rearward position, loosen the jam-nut on the end of the blade stop eye bolt (figure 9).

STEP 3: Move the blade lever to ON position, press the blade pedal forward and hold, then turn the T-nut on end of stop shaft clockwise several complete turns. Make sure tab on T-nut is positioned vertically to fit over the anchor.

STEP 4: Release the blade pedal to allow the blade lever to move to OFF position then depress the blade pedal again and check clearance between forward edge of the blade lever and the rear edge of the latch plate which should be within 1/8" to 1/4". Repeat procedure in step 2 if needed to obtain correct clearance. When correct, hold the blade lever rearward and turn the jam-nut tight against the T-nut to lock in new position.

WHEEL BRAKE TEST & READJUSTMENT

Test the wheel braking action at frequent intervals to insure proper stopping in the event of possible emergencies. Normally, the Rider should stop from top forward speed within approximately four feet after the CLUTCH/BRAKE pedal has been fully depressed.

If the Rider does not stop within this distance, readjust the braking action by repositioning one of the spacers from the topside to the underside of the clutch/brake pedal as shown in figure 10. To do this, pull the rubber pad off the pedal, slide the spacer thru the larger slot in pedal and pad and move it rearward along the brake cable until above the pad and out of the way into the brake cable opening on the side of the center column. Slip the rubber pad over the pedal and test braking action again. If brakes do not stop properly after readjusting, return the Rider to your Snapper Dealer for repair.

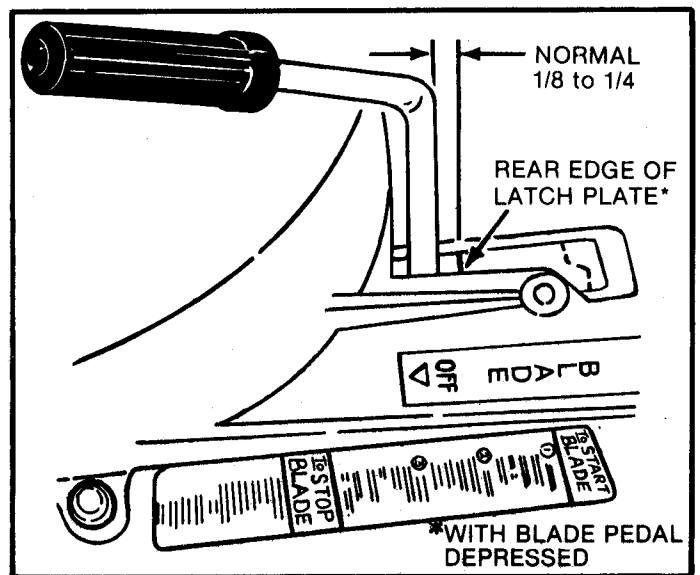

FIG. 8 — BLADE LEVER TRAVEL

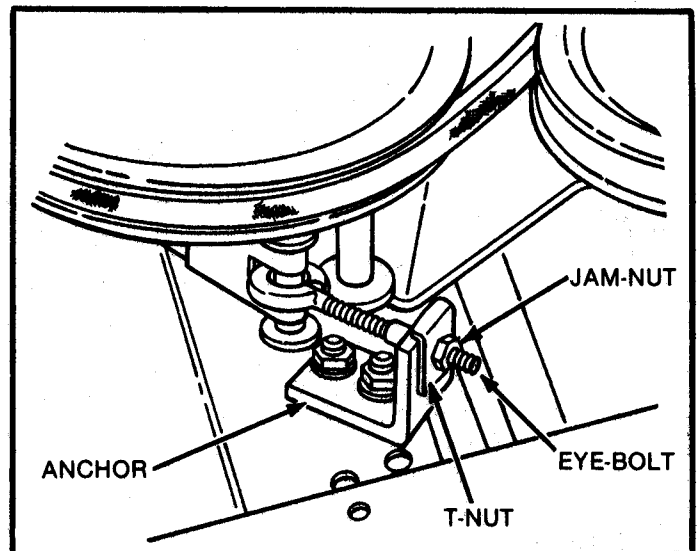

FIG. 9 — BLADE BRAKE ADJUSTMENT

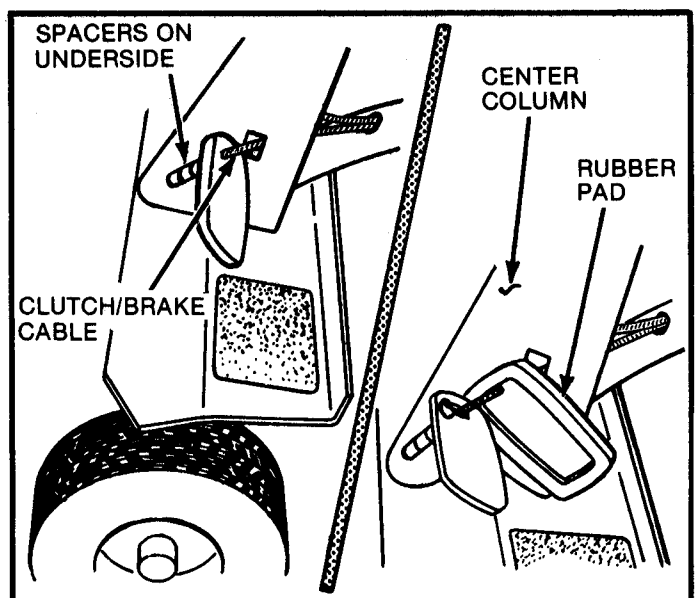

FIG. 10 — CLUTCH/BRAKE ADJUSTMENT

BATTERY SERVICE

Check the battery at least once each month. Remove the caps and add distilled water as required to bring the fluid level above the plates in each cell but no higher than the bottom of the fill rings. In freezing weather, charge the battery after adding water. The engine is equipped with a flywheel alternator to charge the battery. If the engine is not run regularly, connect the battery to a charger a frequent intervals to keep the specific gravity at 1.250 or higher. If lower than 1.175, the battery liquid may freeze when temperatures drop to around zero degrees Fahrenheit. Charge the battery following the instructions furnished with the charger. If time allows slow charge at 1 amp for 10 hours or as an alternate fast charge at 3 amps for 4 hours. Always disconnect the battery negative first and reconnect last. Keep the red boot in position over the positive terminal!

BATTERY STORAGE:

Recharge the battery once each month during the off-season storage period. To prevent damage due to exposed cells, remove the wet cell type battery before standing the mower on end during storage. Store the battery in a vented area preferably where temperatures remain above 32 degrees Fahrenheit but not too warm.

STORAGE PROCEDURE

If desired, stand the mower on end during off-season storage provided the following steps are taken beforehand.

1. Remove wet cell type battery (see BATTERY STORAGE).
2. Thoroughly clean surfaces and lubricate machine (See LUBRICATION SERVICES).
3. Drain fuel from tank and close vent on the fuel filler cap.
4. Service engine for storage as described in the engine owner's manual.

After storing on end, the following steps are required to prepare the engine for operation again. Turn the ignition switch off and pull the rope start handle slowly. If excessive resistance is felt or if the engine refuses to rotate, remove the spark plug and pull rope start again to clear cylinder of oil. Clean and reinstall the spark plug.

MANUFACTURER'S 1 YEAR LIMITED WARRANTY

For 1 Year from purchase date for a non-commercial user, or for Thirty (30) days from purchase date for a commercial user, SNAPPER POWER EQUIPMENT, through any factory authorized service dealer, will replace for the original purchaser, free of charge, any part or parts found upon examination by the factory at McDonough, Georgia, to be defective in material or workmanship or both.

All transportation cost incurred by the purchaser in submitting material to an authorized service dealer for replacement under this warranty must be borne by the purchaser.

This warranty does not apply to engines and their components, as these items are warranted separately by their manufacturers. Neither does it apply to parts that have been damaged by accident, alteration, abuse, improper lubrication, normal wear, or other cause beyond our control.

There is no other express warranty.

Implied warranties, including those of merchantability and fitness for a particular purpose, are limited to one year from purchase date for non-commercial users, and for thirty (30) days from purchase for commercial users and to the extent permitted by law any and all implied warranties are excluded. This is the exclusive remedy. Liabilities for consequential damages under any and all warranties are excluded.

Some states do not allow limitations on how long an implied warranty lasts or do not allow the exclusion or limitation of incidental or consequential damages, so the above limitation or exclusion may not apply to you.

This warranty gives you specific legal rights, and you may also have other rights which vary from state to state.

WARNING: Use of replacement parts other than genuine SNAPPER parts may impair the safety of your mower.

IMPORTANT: Please fill out the attached Snapper Product Registration Card and mail to:

SNAPPER POWER EQUIPMENT
McDonough, GA • 30253

