

# Safety Instructions & Operator's Manual

# **SNAPPER**<sup>®</sup>

**SERIES 8**

**AUTOMATIC BLADE STOP &  
SMOOTH START CLUTCH EQUIPPED**

## **RIDING MOWERS**

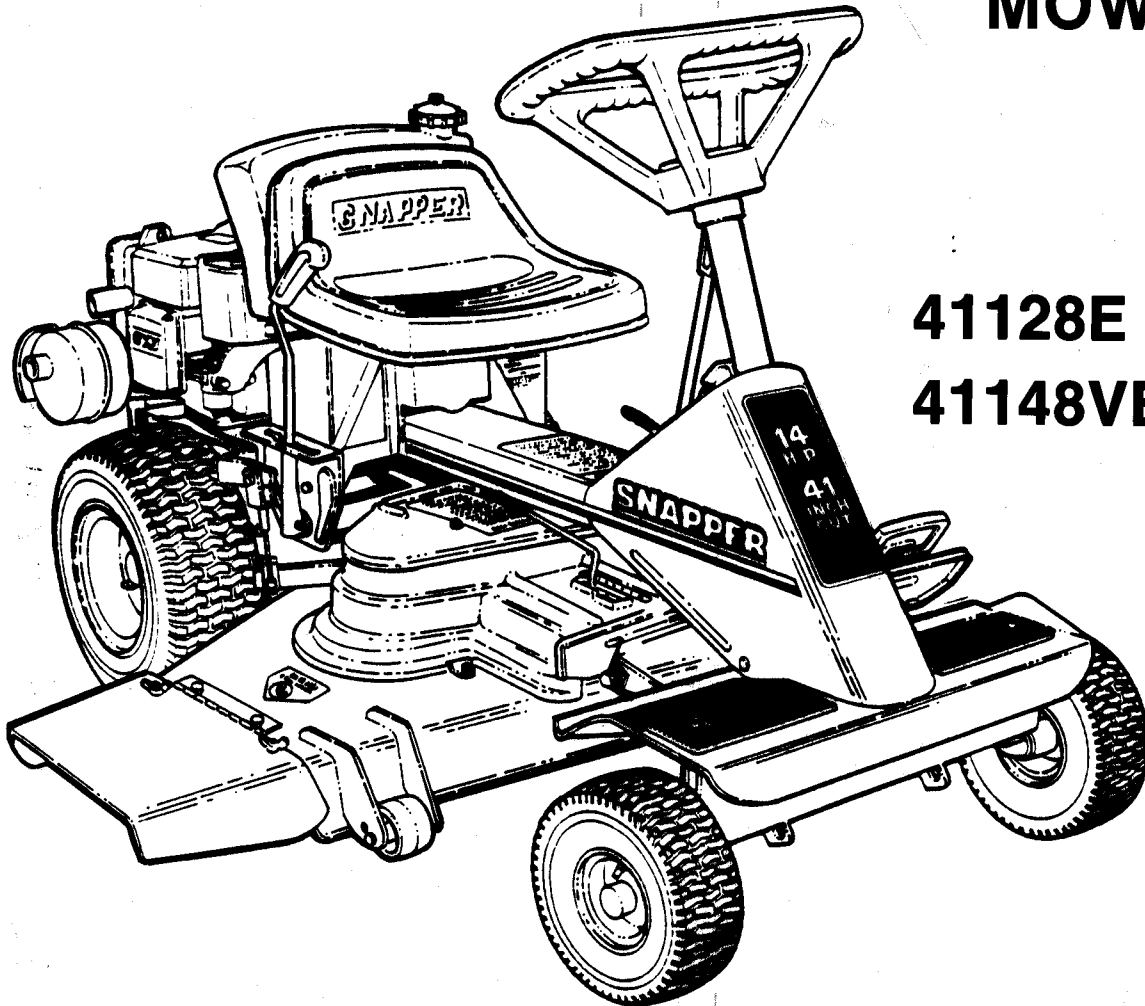

**41128E  
41148VE**

**Thank you for buying a SNAPPER product!** Before operating your mower, read this manual carefully and pay particular attention to the **Important Safety Instructions** on page 2. Remember that mowers and all power equipment can be dangerous if used improperly and keep in mind that safety requires careful use in accordance with the instructions and....common sense!

Your mower is powered by a quality engine which has been specifically selected to match the most demanding operator treatment, and also excel while operating in adverse conditions.

This Operator's Manual covers **SERIES 8** (last number in the five digit model designation) **REAR ENGINE RIDING MOWERS**. The first two digits indicate the width of cut. The next two digits give the horsepower rating. Those having an "E" suffix are Electric Start, and a "V" suffix specifies overhead valve equipped engines.

# IMPORTANT SAFETY INSTRUCTIONS

**WARNING:** This powerful cutting machine is capable of amputating hands and feet and can throw objects that can cause injury and damage! Failure to observe the following safety instructions could result in serious injury. Carefully read this manual and question your dealer if something is not clear. Should the dealer be unable to answer to your satisfaction, write or call the Customer Service Department at **SNAPPER** Power Equipment, McDonough, Georgia 30253 (phone 404-957-9141).

## PROTECTION FOR CHILDREN

1. DO NOT allow children or pets in yard when mower is operated.
2. DO NOT allow children to ride on mower or attachments.
3. DO NOT ALLOW pre-teenage children to operate mower.
4. Only responsible teenagers with mature judgement, physical size and strength to reach and operate controls shall be allowed to operate mower and only under close mature adult supervision.

## PROTECTION AGAINST TIPOVERS

1. DO NOT operate mower on slopes exceeding 15° (27% grade).
2. On slopes above 10° (18% grade); exercise extreme caution; turn blade OFF when traveling uphill; do not mow across; reduce speed to No. 1 position, avoid sharp turns and uphill starting.
3. AVOID UPHILL STARTS. If machine is stopped going up slope, turn blade off and back slowly down slope.
4. DO NOT mow under any condition where traction or stability is doubtful without first test driving over terrain with blade OFF.
5. Stay alert for holes and other hidden hazards and keep away from ditches, washouts, culverts, fences and protruding objects.
6. Always begin forward motion in No. 1 speed position.
7. Use weighted load carrier on front when using grass catcher on slopes above 10° (18%) grade.

## OTHER IMPORTANT PRECAUTIONS

1. Read and follow operator's manuals and instructions furnished with attachments.
2. Only mature, responsible persons shall operate the mower.
3. Mount and dismount mower from left side.
4. Wear appropriate protective clothing when mowing such as substantial footwear and long pants, not barefoot or with open sandals.
5. Practice operation of mower with blade OFF to learn controls and develop skill.
6. Persons under the influence of alcohol or drugs must not operate mower.
7. Know how to stop blade and engine quickly in preparation for emergencies.
8. Keep people and pets a safe distance from mower.
9. Shields, deflectors, switches, blade controls and other safety devices must be in proper position and functional.

10. Clear area to be mowed of wire, rocks and other objects that could cause injury if thrown by blade.
11. Stop the blade, shift to NEU (neutral) and set parking brake whenever leaving mower momentarily with engine running. Make sure blade is stopped by seeing that the belt is not moving.
12. When leaving the mower unattended; shut off engine, shift to a forward speed, set parking brake and remove key.
13. DO NOT operate mower unless properly seated with feet on pads or pedals.
14. Keep hands and feet away from rotating blade underneath deck. Never place feet on ground while blade is ON or when mower is in motion!
15. Turn blade OFF, stop engine and wait for blade to stop before attempting to unclog grass or leaves.
16. Blade must be shifted OFF except when cutting grass. Set deck in highest position when mowing over rough ground.
17. Deflector or grass catcher must be in position. Never point discharge at people, passing cars, windows or doors. Watch out for traffic when crossing or near roadways.
18. Mow in reverse only after careful observation of entire area behind the mower. DO NOT mow in reverse unless absolutely necessary.
19. Service mower and make adjustments only when engine is stopped.
20. Have mower serviced by an authorized **SNAPPER** dealer at least once a year and have the dealer install any new safety devices.
21. Use only genuine **SNAPPER** replacement parts to assure that original standards are maintained.
22. Tighten all nuts, bolts and screws frequently and check, adjust, repair or replace brakes as needed.
23. Lubricate mower at intervals specified in manual to prevent controls from binding.
24. Mow only in daylight or in good artificial light.
25. Handle gasoline with care! Never remove cap while engine is running. Fill tank outdoors only with engine stopped and cool. Clean spilled gasoline from machine. Store gasoline in approved container, out of the reach of children, in well ventilated, unoccupied building.
26. DO NOT run engine indoors. Exhaust fumes are dangerous. Carbon monoxide is a colorless and odorless gas which can seriously impair the health of persons and pets!
27. DO NOT change engine governor speed settings or overspeed engine.
28. Check grass catcher components frequently for signs of wear or deterioration and replace as needed to prevent thrown objects from going through weak or worn spots.
29. Exercise caution when pulling loads. Limit loads to those you can safely control and attach loads to hitch plate as specified with **SNAPPER** attachment instructions.

# INTRODUCTION

This manual covers SNAPPER Series 8 Automatic Blade Stop and Smooth Start Clutch equipped rear engine riding mowers. Series 8 riders (last numeral is the MODEL designation) feature a parking brake lever which is located on the instrument panel.

See your SNAPPER Dealer for information on the many accessories available for your riding mower and examine SNAPPER'S complete line of outstanding power equipment!

Always stop the blade, shift into neutral and set the parking brake when it becomes necessary to leave your rider momentarily while the engine is running!

FIG. 1 - LOCATION OF CONTROLS/FEATURES

## OPERATING/SERVICE FEATURES

- 1-C Battery
- 2-C Belt Cover
- 3-C Blade Lever
- 4-C Blade Pedals
- 5-C Clutch/Brake Pedal
- 6-C Cutting Height Lever
- 7-C Discharge Deflector
- 8-C Engine Control Lever
- 9-C Front Tire (20 P.S.I.)
- 10-C Fuel Filler Cap/Valve
- 11-C Ignition Key/Switch
- 12-C Operator's Seat
- 13-C Parking Brake Lever
- 14-C Rear Bumper
- 15-C Rear Tire (12 P.S.I.)
- 16-C Rope Start Handle
- 17-C Transmission Shift Lever

← LEFT SIDE

RIGHT SIDE →

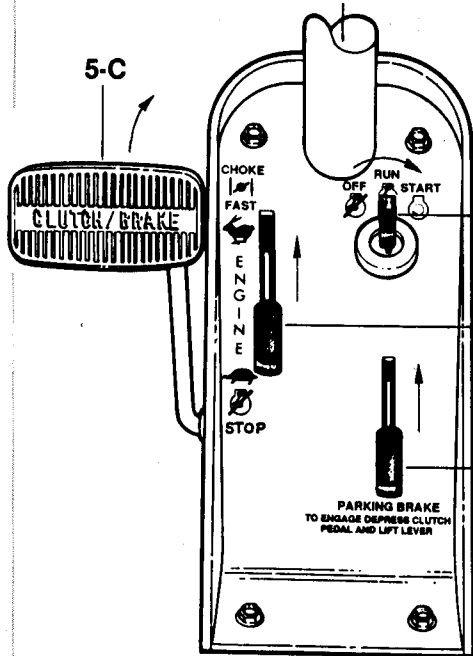
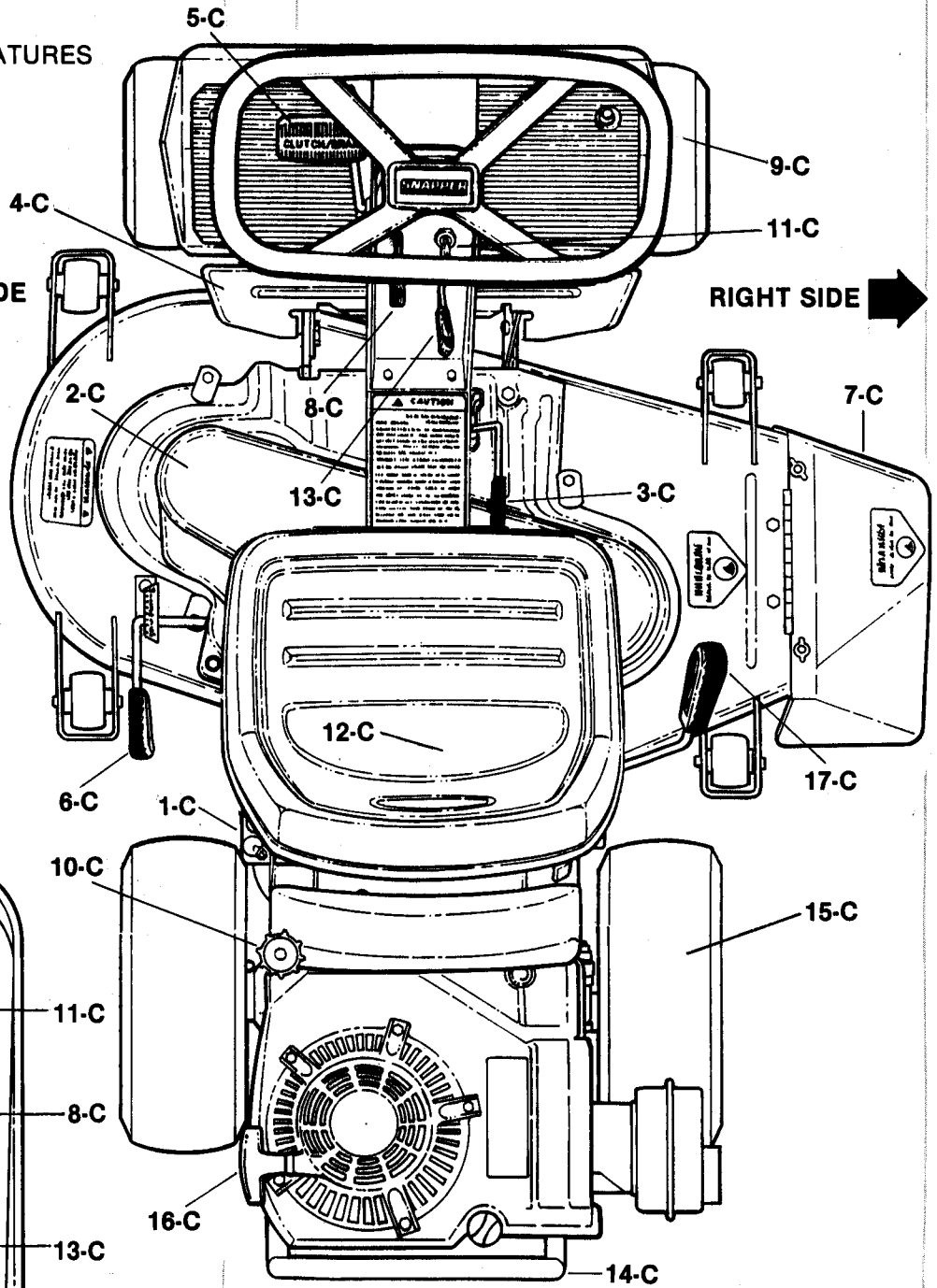

FIG. 1-A CLUTCH/BRAKE DETAIL

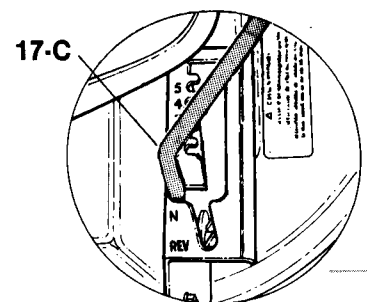
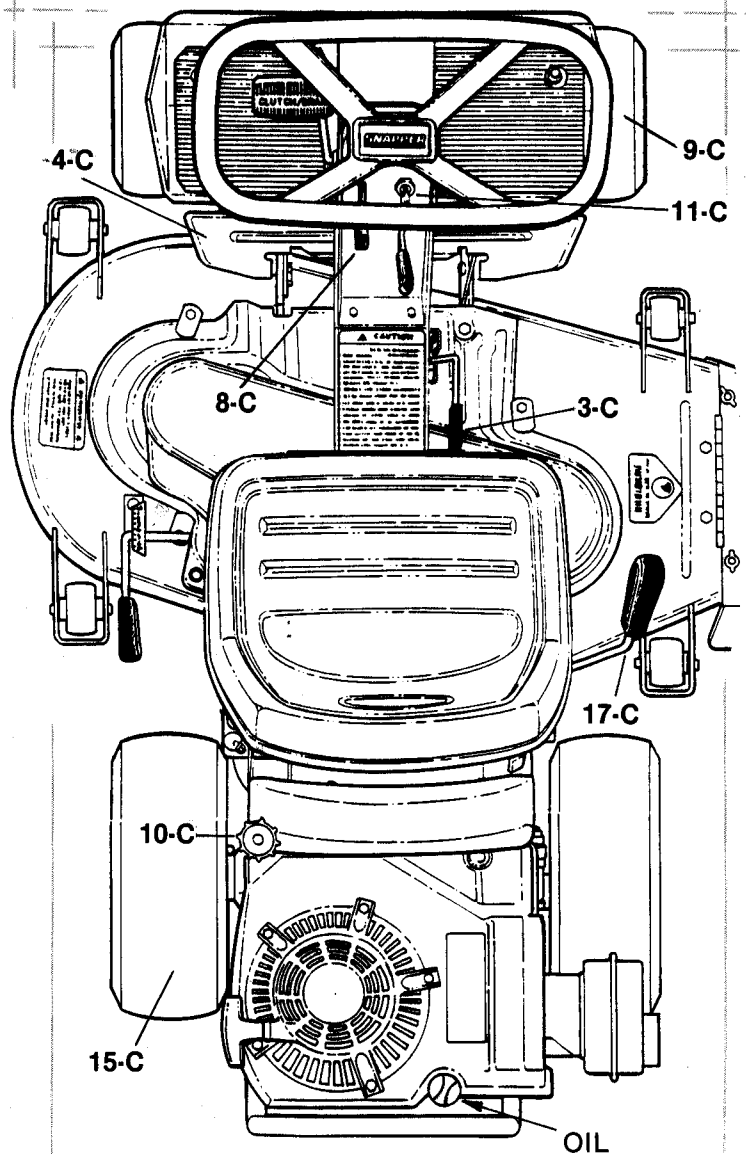
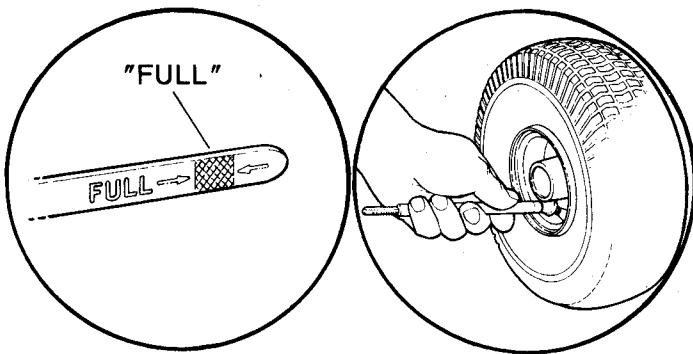

FIG. 1-B SHIFT LEVER DETAIL

To set the parking brake, depress the CLUTCH/BRAKE pedal (5-C) down and then move (lift) the PARKING BRAKE lever (13-C) forward and then release foot pressure until the PARKING BRAKE lever locks into place. To release the parking brake, tap the CLUTCH/BRAKE pedal with your foot.

## PRE-START CHECKS & SERVICE

- CHECK BLADE CONTROLS.** The controls must work freely and be properly adjusted. The **BLADE lever (3-C)** must "snap" from ON to OFF when the **BLADE pedals (4-C)** are released.
- CHECK GUARDS, DEFLECTORS & COVERS.** They must be in place and securely fastened.
- CHECK ENGINE OIL.** The oil level should be at the "FULL" mark on the dipstick - never over fill! Add oil if needed (refer to engine manual for oil specifications).
- CHECK TIRES.** Air pressure should be 20 p.s.i. in the front tires (9-C) and 12 p.s.i. in the rear tires (15-C). Add air if needed.
- CLEAN EXTERIOR SURFACES.** Remove any accumulation of dirt, grass, oil, etc. from the engine and mower deck. Keep the engine air intake screens and cooling fins clean at all times.
- ADD FUEL.** Pour fuel into the tank only when the rider is **OUT - DOORS** where fumes can safely dissipate. Make sure the **FUEL FILLER CAP (10-C)** is tightened after each refueling.



## STARTING & STOPPING ENGINE

**NOTE:** To stop the engine, either turn the **IGNITION KEY (11-C)** OFF or move the **ENGINE CONTROL lever (8-C)** rearward to **STOP** and then turn **IGNITION KEY** off.

**START ENGINE AS FOLLOWS:**

**STEP 1:** SHIFT **BLADE lever (3-C)** to OFF and the **TRANSMISSION SHIFT lever (17-C)** to **NEU (Neutral)** - interlocks will then allow the engine to start.

**STEP 2:** Open **CAP VENT/FUEL VALVE (10-C)** - turn the fuel filler cap "valve" counter-clockwise until it stops. Open shut-off valve if rider is so equipped.

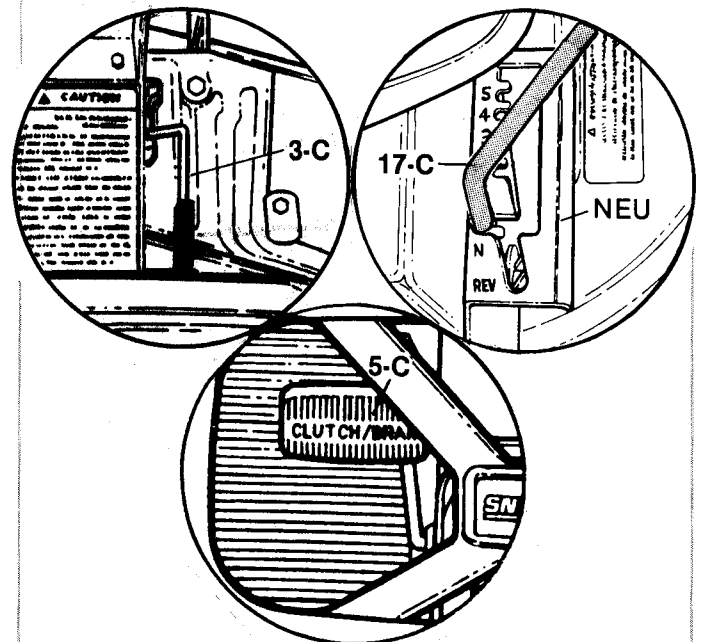
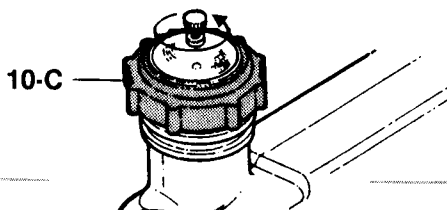

**STEP 3: CHOKE ENGINE** - To start a cold engine, move Engine Control Lever (8-C) to the CHOKE position.

**STEP 4: MANUAL START ENGINE** - Turn the Ignition Key (11-C) to RUN and pull rope Start Handle (16-C) to start engine.

**STEP 4-A: ELECTRIC START ENGINE** - Turn the Ignition Key (11-C) to START and hold until engine starts.

Release the key (to cool starter) if the engine has been cranked for approximately 5 seconds and fails to start. Then try again.

**NOTE:** Should the battery ever be too weak to electrically start the engine, manually start it with the ROPE START handle (16-C). Remove the battery and connect to charger. Never "Boost" charge a battery - to prevent possible battery damage, always slow ("Trickle") charge a battery.

**STEP 5: ENGINE WARM-UP** - After a brief period at the CHOKE position, move the Engine Control Lever (8-C) rearward until the engine runs smoothly. Set the lever at or near FAST for best cutting and bagging performance.

**STEP 6: STOP ENGINE** by turning the Ignition Key (11-C) left to OFF or by moving the Engine Control Lever (8-C) rearward to STOP.

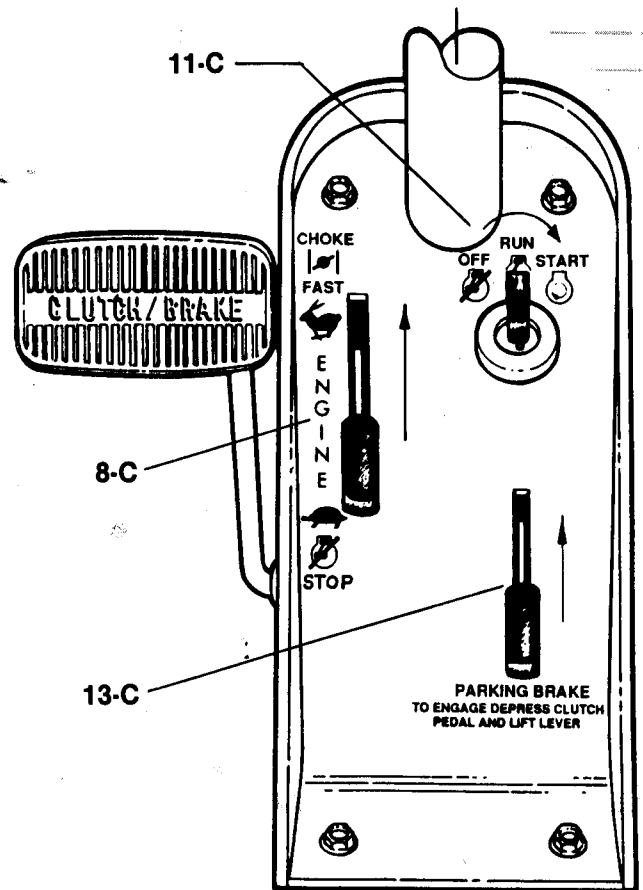

## STARTING/STOPPING RIDER

**Become thoroughly familiar with the location and function of the forward & reverse direction controls: CLUTCH/BRAKE pedal (5-C), PARKING BRAKE Lever (13-C), and the TRANSMISSION SHIFT lever (17-C) (refer to FIG. 1).**

**FORWARD DIRECTION:** When partially depressed, the CLUTCH/BRAKE pedal (5-C) functions as a clutch, permitting shifting from neutral into either forward or reverse. Further depression of the pedal provides braking. When depressed, the pedal can be set for parking (refer to FIG. 1-A).

After shifting the TRANSMISSION SHIFT lever (17-C) into the #1 speed position, release the pedal to begin forward movement. Move the lever forward or rearward while traveling forward (without depressing the pedal) to shift into higher or lower FORWARD speeds.

**NOTE:** The rider can roll if the TRANSMISSION SHIFT Lever (17-C) is in neutral and the parking brake is NOT set!

**REVERSE DIRECTION:** Before shifting into reverse, fully depress the CLUTCH/BRAKE pedal (5-C) to stop. Move the TRANSMISSION SHIFT lever (17-C) rearward into REV position and then completely release the pedal to begin moving in reverse. To stop while in reverse, fully depress the pedal.

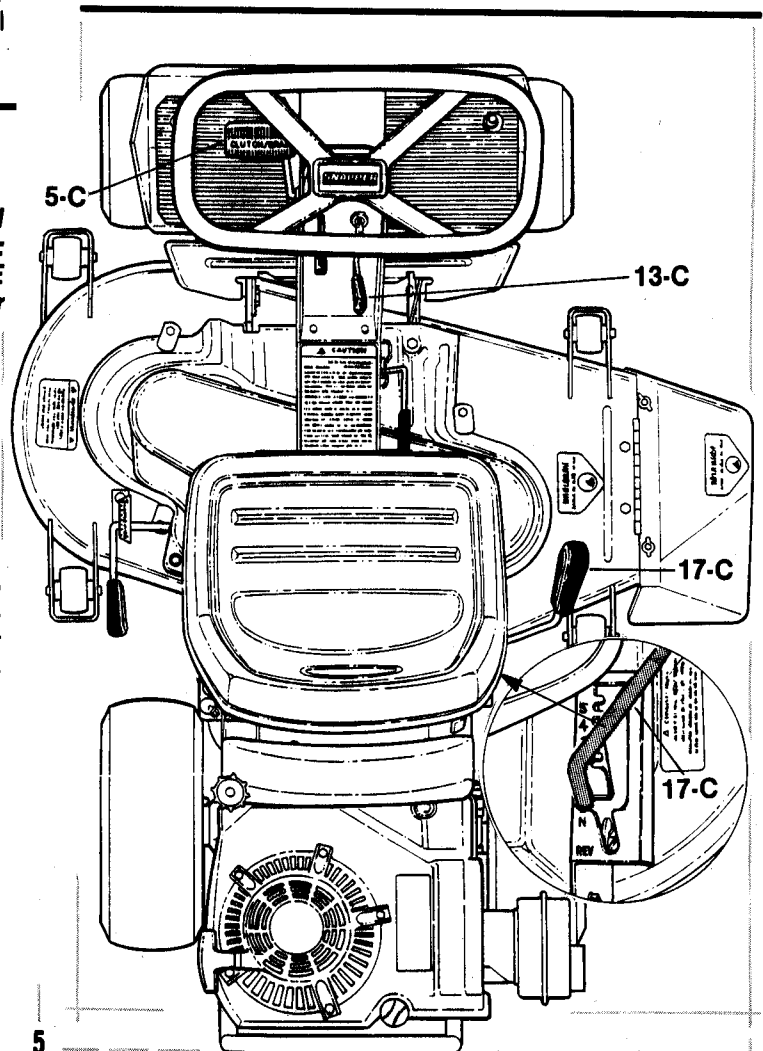

## STARTING & STOPPING MOWER BLADE

The Automatic Blade Stop Controls should stop the blade in less than 3 seconds - after the BLADE pedals (4-C) are released. The BLADE lever (3-C must be shifted forward first, then the pedals are depressed to keep the blade engaged.

**NOTE:** The BLADE lever will NOT move forward if the BLADE pedals are depressed first!

Start and Stop blade as follows:

**STEP 1:** Shift BLADE lever forward to ON and hold in position. Then depress the BLADE pedals - keep your heel(s) on the pedals to "lock" the blade into the mowing (rotating) sequence.

**NOTE:** If STEP 1 is followed, the blade will rotate whenever the engine is running.

**STEP 2:** To stop the blade, remove your heel(s) from the BLADE pedals. The spring loaded BLADE lever will then snap rearward to OFF.

**NOTE:** The BLADE lever can be forced into OFF position while the BLADE pedals are depressed, by pushing the BLADE lever inward, and then pull rearward into OFF.

**NOTE:** If the BLADE lever moves SLOWLY rearward rather than snapping back, the belt may be too slack, or the linkage may need lubrication.

Adjust the belt and lubricate the mower (as described in the SERVICE section), and check the blade stopping time. If the time exceeds 3 seconds, adjust the blade brake as described on page 9. If the stopping time still exceeds 3 seconds, the mower should not be operated until inspected/repaired by your dealer.

## SERVICE

### SERVICE ASSISTANCE/REPLACEMENT PARTS

By returning your mower to an Authorized **SNAPPER** Dealer on a yearly basis for inspection and addition of any new devices to upgrade your mower, the safety of the unit's functions will be assured.

Check the yellow pages under **LAWNMOWERS** for the nearest **SNAPPER** Dealer. Always mention the model and serial number of your mower when contacting the dealer for parts, service, or information.

For engine parts/service, check under **ENGINES** - gasoline, for nearest engine manufacturer's dealer.

**NOTE:** Always take the following steps before standing your **SNAPPER** rear engine rider on the **REAR BUMPER**.

1. TIGHTEN FUEL FILLER CAP (10-C)
2. CLOSE (TURN CLOCKWISE) THE VENT VALVE ON FUEL FILLER CAP (10-C)
3. REMOVE THE BATTERY (1-C) IF THE UNIT IS TO BE STOOD ON END LONGER THAN 2 HOURS.

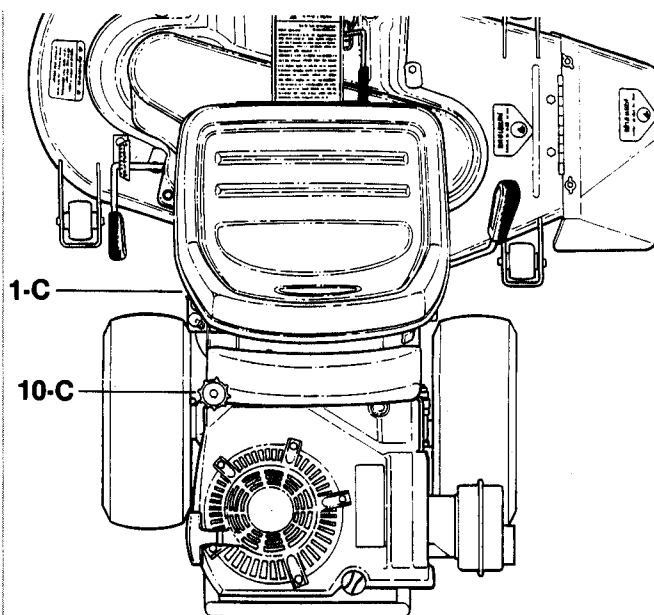
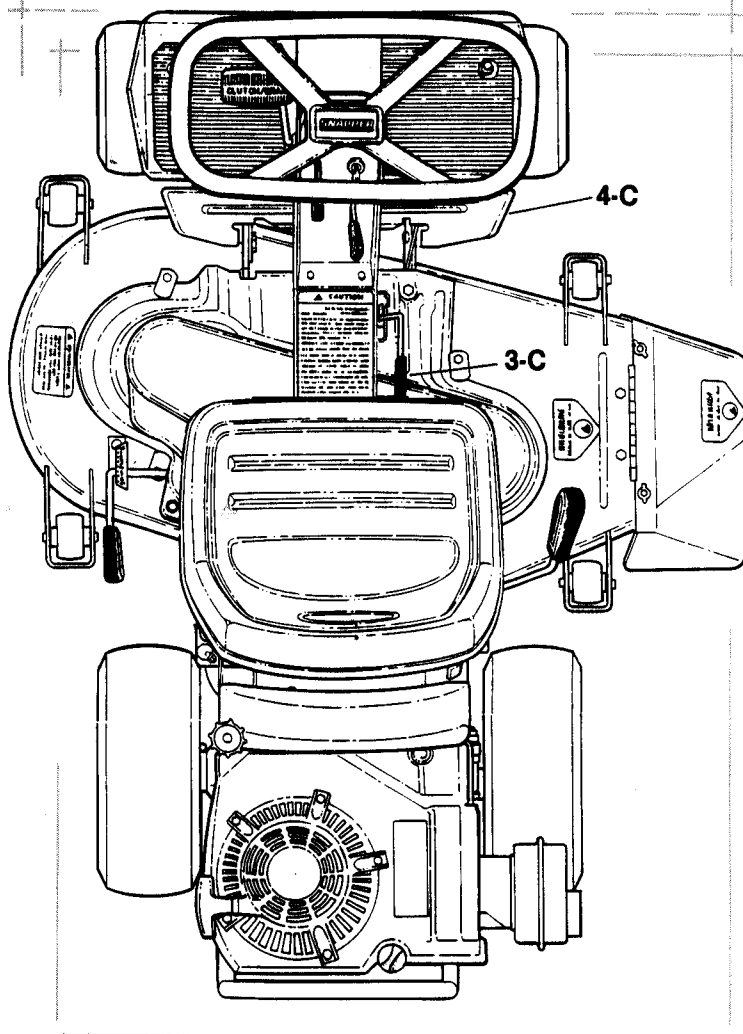

It is recommended that rear engine riders sit on the **REAR BUMPER** during the servicing of lubrication points on the underside. When preparing to raise the front, position **BOTH** hands near the center of the front frame "lip" to prevent any possibility of having fingers pinched by tie rods.

It is recommended that you use Genuine **SNAPPER** Replacement Parts to retain the integrity of your mower.

# LUBRICATION SCHEDULE

## EVERY 25 OPERATING HOURS:

● **FRONT WHEEL BEARINGS:** Lubricate through grease fittings (6-L) with bearing grease from a pressure gun.

**NOTE:** These riders have a sealed REAR LEFT AXLE BEARING which does not require lubrication. The REAR RIGHT AXLE BEARING is lubricated by the transmission.

FITTINGS UNDER BLADES

## ENGINE SERVICE

● **ENGINE:** Change oil per instructions in engine manual. Check oil level before each use.

● **AIR CLEANER:** Clean and/or replace air cleaner element(s) per instructions in engine manual.

It is recommended that the air cleaner be periodically inspected when adding fuel, and inspected more frequently when the machine is operated in dry, dusty environments.

## EVERY 6 MONTHS:

● **CUTTING HEIGHT LEVER (6-C):** Remove the BELT COVER (2-C) from deck and apply a small amount of medium grade cup grease to top surface of adjusting cams on both sides, and lubricate idler arm.

● **BLADE LEVER (3-C):** Lubricate idler arm and engagement lever at each wear point with a few drops of oil. Also lube arm at pivot to spindle housing.

● **BLADE PEDALS (4-C):** Lubricate all pivoting and sliding surfaces where motion occurs (when pedals are moved) with a few drops of oil. Reinstall BELT COVER.

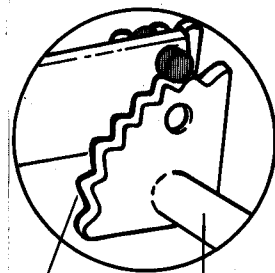

LUBE CAM 6-C

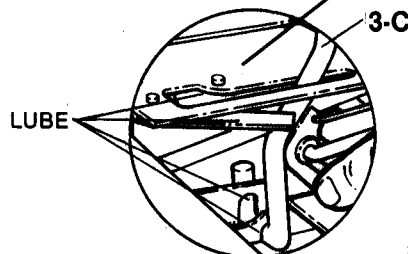
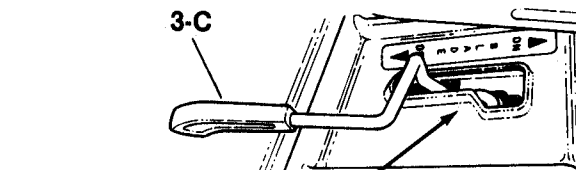

LUBE 3-C

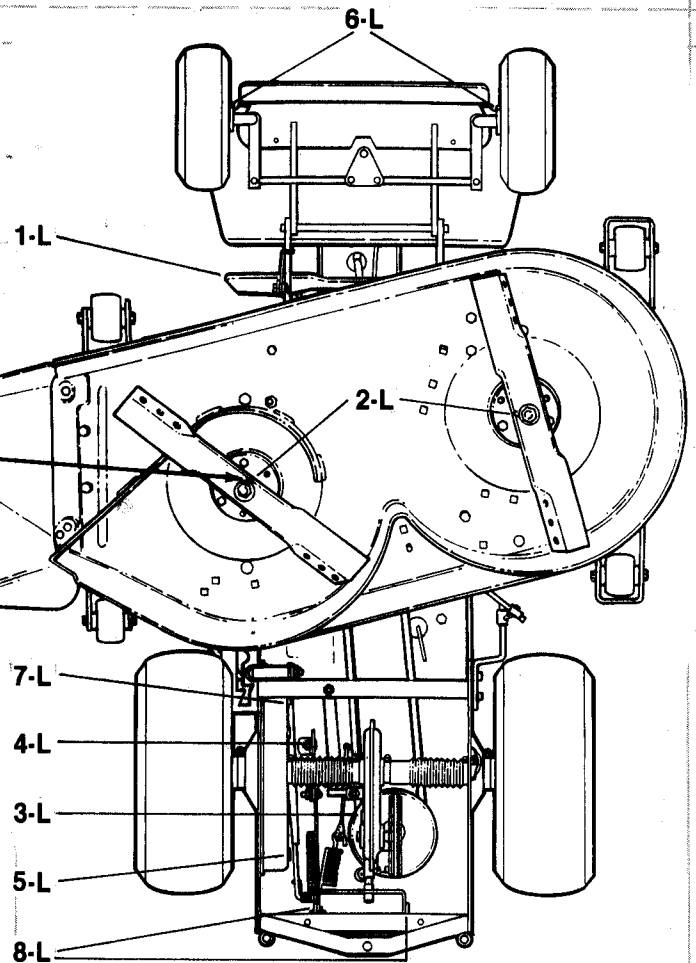

- 1-L BLADE PEDAL - Pivot Points
- 2-L BLADE SPINDLE - Grease Fittings
- 3-L CHAIN CASE - Check Plug
- 4-L CLUTCH ROD & GUIDE
- 5-L DIFFERENTIAL - Check Plug
- 6-L FRONT WHEEL - Grease Fittings
- 7-L SHIFT ARM - Pivot Points
- 8-L YOKE - Pivot Points

FIG. 2 - LUBRICATION & SERVICE POINTS

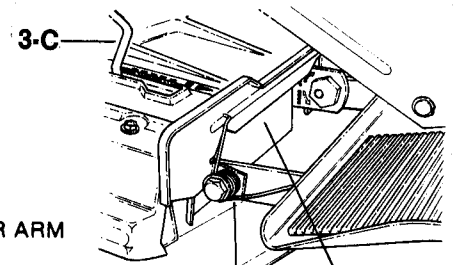

LUBE 3-C 4-C/H-L

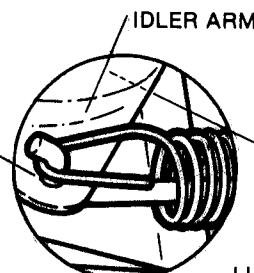

LUBE UNDER ARM

FIG. 2-A

FIG. 2-B

## ONCE A YEAR

### STAND MOWER ON REAR BUMPER

● **BLADE SPINDLE**: Two shots of grease through grease fittings (2-L) are required. The fittings are located between the deck and the blades.

FIG. 3  
BLADE  
SPINDLES

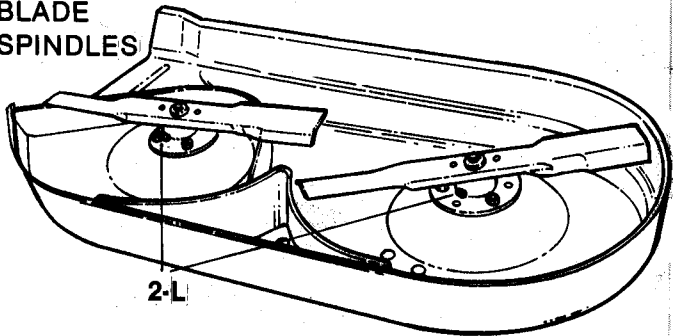

● **DIFFERENTIAL**: Remove the DIFFERENTIAL CHECK PLUG (5-L) at A. If the level of grease is below the bottom edge of hole, add **SNAPPER** 0 grease until it reaches the bottom edge, by removing the plug at B and filling the differential through that hole. Install new plugs after servicing.

● **CHAIN CASE**: Remove CHAIN CASE CHECK PLUG (3-L) and add about 1 ounce of **SNAPPER** 0 grease to case if low - avoid over filling. Total capacity must not exceed 2 ounces. Install new plug.

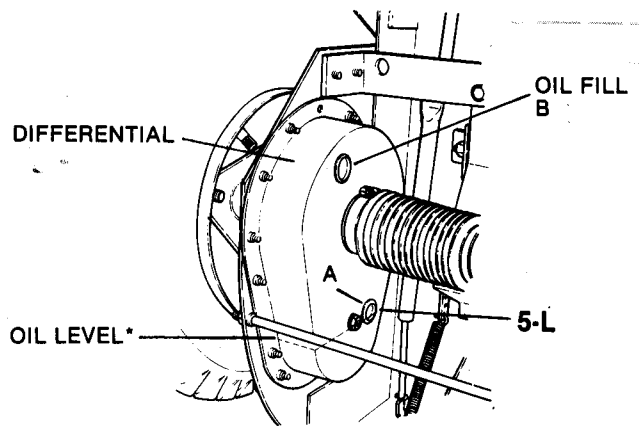

\*With mower standing on end

FIG. 4 - DIFFERENTIAL LUBE LEVEL

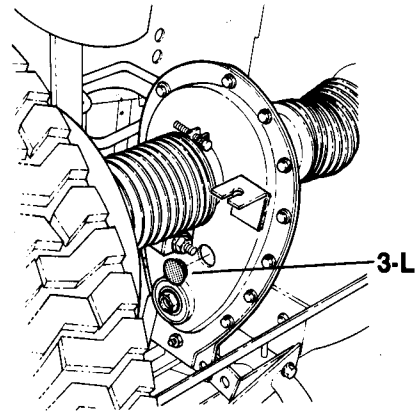

FIG. 5 - CHAIN CASE

## FUEL FILTER

The in-line filter (between fuel tank and engine) protects the engine from damage due to gasoline impurities.

Replace the filter before it becomes completely clogged with sediment. If the engine becomes "starved" for fuel - it will not accelerate properly, misses, or stalls under load, the filter should be replaced. Also check for any fuel leakage around hose clamps - correct with new clamps and/or hose if there is any seepage!

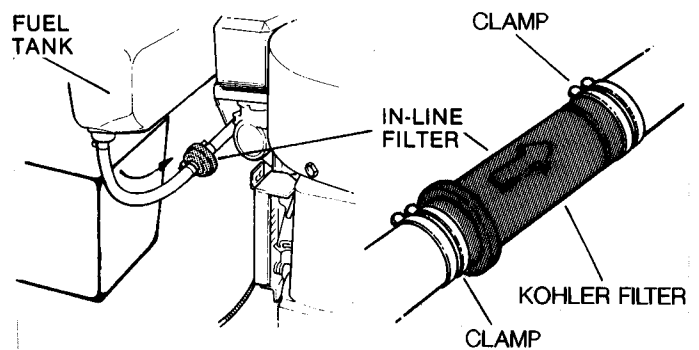

FIG. 6 - FUEL TANK & FILTER

## OPERATOR'S SEAT

The Operator's Seat (12-C) may be moved either forward or toward the rear of unit to enable individuals of varying heights to comfortably steer and control the rider.

To adjust the seat, loosen the 2 three prong knobs (A) located on the underside of the slotted mounting bracket. Move the seat in the desired direction, and then retighten both knobs.

Also, for taller operators, the offset steering wheel may be rotated 180 degrees. If assistance is needed, contact your **SNAPPER** Dealer.

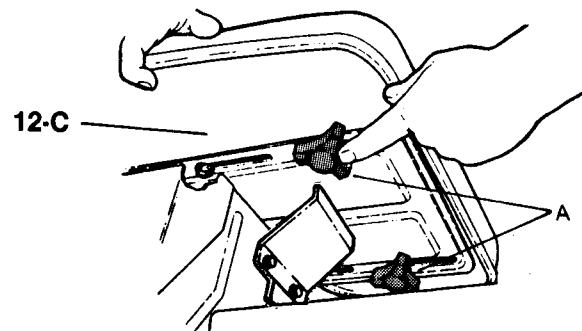

FIG. 7 - CHECK SEAT RETAINER SCREWS



## BELT TENSION ADJUSTMENT & REPLACEMENT

Shut the engine off first! DISCONNECT THE SPARK PLUG WIRE, and then remove the belt cover.

With the mower deck in #5 height position and the blade in the ON position, check the distance between the inside surfaces of the belt as shown in FIG. 9. The belt tension is adjusted by changing the "distance" between the front axle and the rear case. Loosen nut (Y) at the main tube clamp (X) beneath the main channel (under seat) and pull the front assembly FORWARD to increase belt tension until the correct amount is achieved. Then retighten nut (Y).

After "distance" has been changed, check operation of the clutch/brake pedal and readjust the brake control cable, if needed, for proper traction and braking. Refer to the Brake section.

If belt becomes frayed, cracked, or worn, replace as follows: Remove the BELT COVER, then cut and remove the old belt. To install new belt, close fuel cap (10-C) valve. Stand mower on REAR BUMPER (14-C), shift into NEU. position, work belt between discs, shift into #5 speed and push belt over edge of engine drive disc. Work into the groove of the drive disc, then connect other end to pulleys on mower deck as follows: Loosen or remove the idler pulley, loop the belt around spindle pulley as shown in FIG. 9 and work belt between restrictor and idler pulley. Make sure locking tab on restrictor is engaged in idler arm before securing idler arm nut and bolt. Check and adjust belt tension as needed before reinstalling BELT COVER.

## BLADE BRAKE ADJUSTMENT

As the brake band wears, the BLADE lever will gradually stop further rearward in the slot of the BELT COVER. BRAKE adjustment is required when the lever stops 1/2" from the top of the belt cover. The adjusting point is shown in FIG. 11. With the engine stopped, the adjustment is made as follows:

STEP 1: Lower cutting deck and remove the BELT COVER.

STEP 2: While holding the BLADE lever firmly in the rearward position, loosen the jam-nut on the end of the eye bolt (refer to FIG. 11).

STEP 3: Move the BLADE lever to the ON position, press the BLADE pedals down and hold, then turn the T-nut on end of eye bolt (clockwise) several complete turns. Make sure tab on T-nut is positioned vertically to fit over the anchor.

STEP 4: Release the BLADE pedals to allow the BLADE lever to move to the OFF position, then depress the BLADE pedals again and check the clearance between forward edge of the BLADE lever and the rear edge of the latch plate which should be less than 1/4" (FIG. 10). Repeat the procedure in step 2 if needed to obtain correct clearance. When correct, hold the BLADE lever rearward and turn the jam-nut tight against the T-nut to lock in new position. Reinstall BELT COVER.

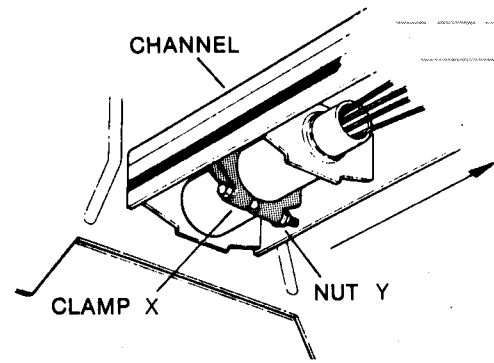

FIG. 8 - TUBE CLAMP

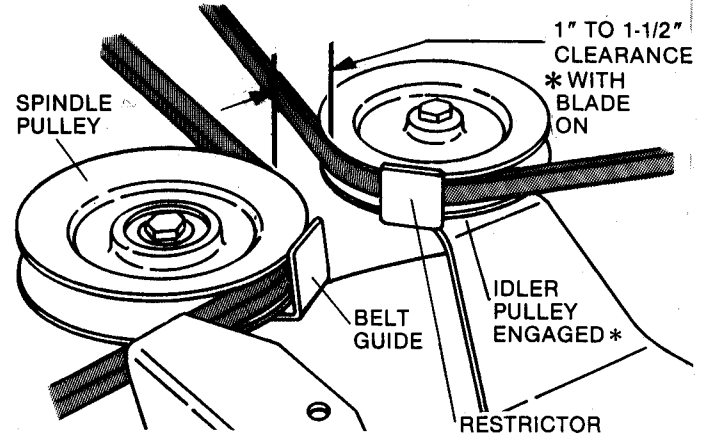

FIG. 9 - BELT TENSION

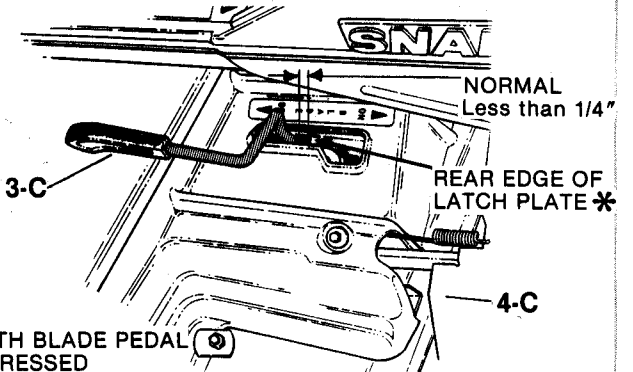
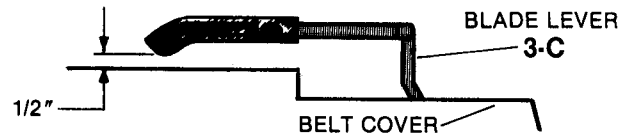

FIG. 10 - BLADE LEVER TRAVEL

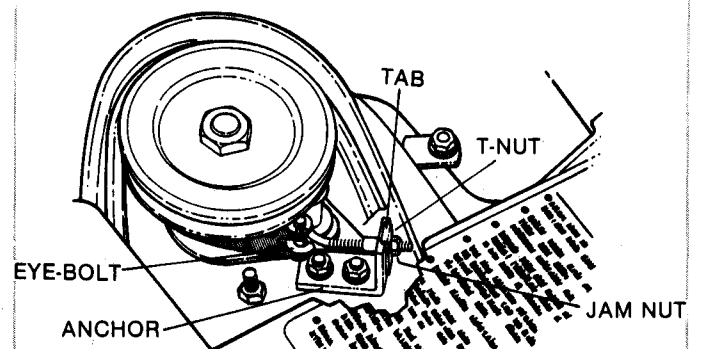

FIG. 11 - BLADE BRAKE ADJUSTMENT

## WHEEL BRAKE TEST & ADJUSTMENT

Test the wheel braking action at frequent intervals to insure proper stopping in the event of possible emergencies. Normally, the rider should stop from FAST (top forward speed) within approximately three feet after the CLUTCH/BRAKE pedal has been fully depressed.

**WARNING:** Always disconnect the spark plug wire and secure the end away from the plug before inspecting/servicing the rider/mower, to prevent unintentional start-ups.

Prior to making brake adjustment, check to see that the mower belt is adjusted properly.

Stand the rider on its REAR BUMPER (14-C), engage the PARKING BRAKE (13-C), shift the TRANSMISSION SHIFT lever (17-C) to the #3 speed position, and then check the distance between the DRIVEN DISC rubber drive ring and the surface of the drive disc. There should be between 1/16" and 1/8" clearance.

If the proper distance is not evident, the clutch/brake cable needs to be adjusted. Release the parking brake, rotate the clutch yoke to provide slack in the cable, and then move 1 of the spacers (Y) through the "keyhole" slot in the top of clutch arm (X) to the end of cable. Re-engage the parking brake and again check the clearance between the rubber ring and the drive disc. Repeat this procedure until the proper distance is achieved.

## CLUTCH ADJUSTMENTS

The clutch is initially set for smooth action under normal load conditions. It can be readjusted to pull heavy loads. Adjustment is made by repositioning the yoke lift spring. Initially, the spring is hooked in the middle hole in the clutch link (which has 3 holes). For more traction, increase spring tension by reconnecting to the top hole of the guide link. For smoother action, reconnect the spring to the bottom hole of the link.

## CUTTING BLADE SERVICE

**BE CAREFUL:** Avoid cutting yourself on a sharp blade! Wear gloves to protect your hands while handling the blades.

Check the blades at frequent intervals for proper tightness and operating condition. Replace if chipped, bent or notched. Sharpen if in otherwise good condition-at an angle of 22-28 degrees inward about 2-1/2" from tips. Check blade for balance and correct to prevent vibration. Install the blade with retaining hardware as shown in FIG. 14 and tighten to torque specified.

FIG. 14  
BLADE  
RETENTION  
DETAIL

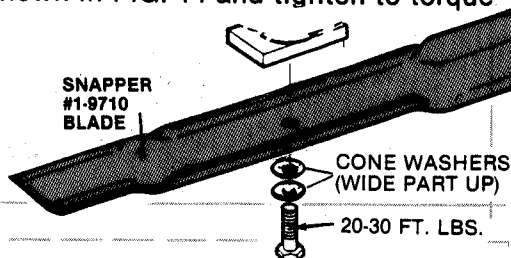

To adjust the brake (with the parking brake on), loosen both jam nuts (A) which secure the clutch/brake cable threaded tube (B) to the chain case bracket as shown. Then, by screwing the two jam nuts up or down, the tube can be moved to change the distance the cable end is recessed INSIDE the spring guide (tube), which is attached to the brake lever. Adjust the threaded tube up or down until the cable end is recessed between 1/8" to 3/8" from the cotter pin. Retighten both jam nuts (A) against bracket (C).

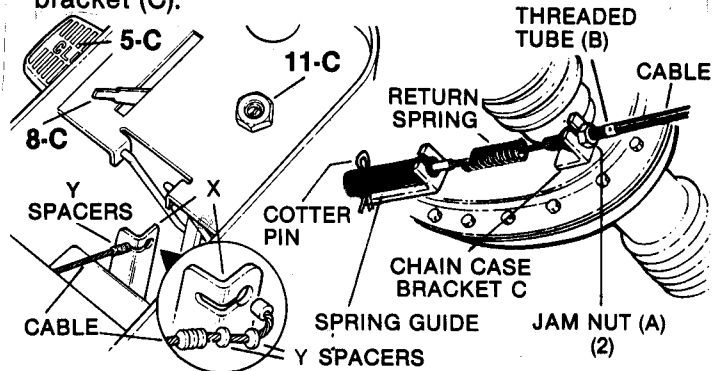
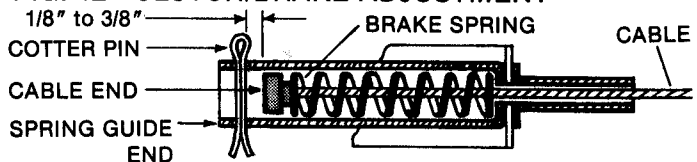
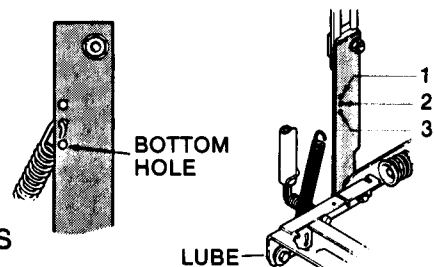

FIG. 12 - CLUTCH/BRAKE ADJUSTMENT



Additional adjusting can be made by moving the other threaded tube up or down. It is located under/inside the front of the main channel and above the mower deck.

FIG. 13  
CLUTCH  
ADJUSTMENTS



## CUTTING DECK SERVICE

If the mower cuts an "uneven" swath, follow the procedures below:

1. Slow the rider's forward movement (shift into a lower range) and move the ENGINE CONTROL LEVER (8-C) toward FAST.
2. Check belt tension (refer to BELT ADJUSTMENT section).
3. If the cut is uneven from side to side, check tire pressure. The front should be 20 p.s.i. and the rear are properly inflated at 12 p.s.i..
4. If an uneven pattern persists, roll the rider onto a smooth, flat, level surface (such as a garage floor), turn the ignition key (11-C) to OFF, and be sure the BLADE lever (3-C) is in the OFF position. Check the mower deck settings as follows:

**BLADE TO BLADE ALIGNMENT:** Close the FUEL FILLER CAP/VALVE (10-C) and then stand the rider on the REAR BUMPER (14-C). Rotate blade X's tip 1 and blade Y's tip 3 to point C. There should be  $\frac{1}{8}$ " or less difference in tip alignment. Then rotate both blades again until tip 2 and tip 4 meet at point C.

If either set of tips have more than  $\frac{1}{8}$ " difference in alignment, the straightness of both blades should be checked. If either or both blades are bent, they should be replaced with SNAPPER #1-9710 blades. If both blades are straight, one of the deck spindles may be misaligned and you should consult your SNAPPER Dealer. Lower the rider back down on its wheels.

**SIDE TO SIDE LEVEL:** Raise the deck and place a piece of angle iron (or other triangular shaped block) under the deck at the center of the rear lip. Lower deck onto the block.

Rotate blade X's tip 1 to point A on deck so that the blade is perpendicular to the rider body. Measure the distance from tip 1 to the floor. Rotate blade Y's tip 4 to point B and measure the distance to the floor. The deck is considered level if any difference between the two measurements is  $\frac{1}{8}$ " or less.

If there is more than  $\frac{1}{8}$ " difference between the two measurements, the deck must be leveled by means of the ECCENTRIC, which is located on the inside of the mower's front LEFT lift arm. Loosen the shoulder bolt, rotate the eccentric toward UP or toward DOWN as needed. Hold in place while retightening the shoulder bolt. Remove the block, and measure the distance from each blade's outside tip to the floor.

**FRONT TO REAR ADJUSTMENT:** The distance the mower deck is from the ground surface is pre-set at an optimum level. Should the deck pitch ever need to be "fine tuned", the adjusting nuts "A" should be screwed in or out only by a technician at your SNAPPER Dealer. Timing rod "B" maintains the levelness of the deck - front to rear as the deck is raised or lowered.

Rotate blade Y's tip 3 to point D (at the front of deck) and measure the distance from tip to ground. Then rotate the blade so that it is again parallel with the rider body (frame). Tip will be at point E - measure the distance from the tip to the ground surface. The distance at point E should be  $\frac{1}{4}$ " MORE than the distance at point D.

To reset the deck (distance from the ground surface), raise or lower the rear lift arms. Raise deck and place a block under deck at the CENTER of the REAR lip. Lower the deck onto block to permit cable slack. Remove pin from clevis "A"/lift arm on each side of rider and relocate an equal number of spacers (through key hole in clevis) either BELOW clevis (to raise deck), or ABOVE clevis (to lower the deck). Reinstall pins, raise deck, and remeasure front and rear distance after removing block. Adjust as needed until the  $\frac{1}{4}$ " difference is achieved.

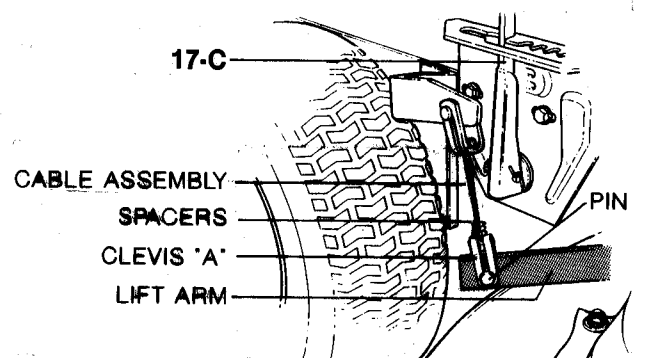
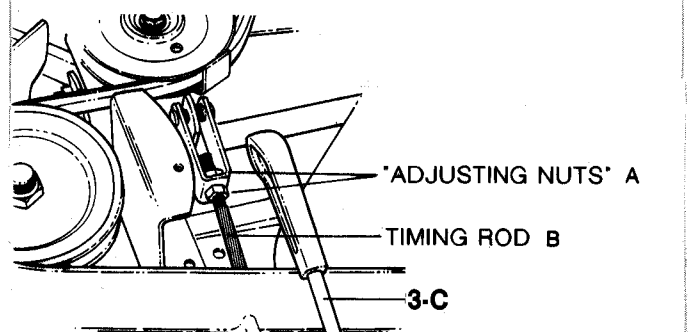
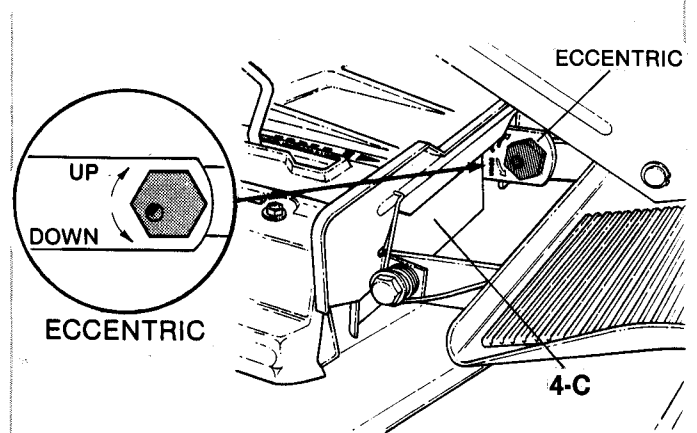
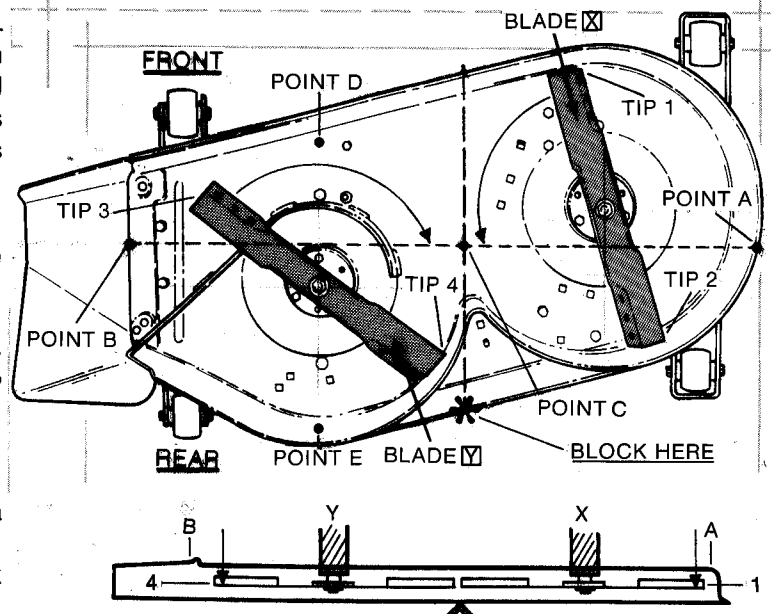

Contact your SNAPPER Dealer if an "uneven" mowing pattern persists after you have followed the inspection and adjusting procedures.

## BATTERY SERVICE

Check the fluid in the battery at frequent intervals to make sure the level is above the MIN. FILL line. To keep the fluid in proper range, remove the cell caps and add distilled water as needed to bring the level in each cell up to but not over, the MAX. FILL line. In freezing weather, always charge the battery after adding water. The engine is equipped with a flywheel alternator to maintain battery charge when run frequently. Keep the specific gravity of the battery above 1.250—if lower than 1.175, the battery liquid may freeze at temperature around zero degrees Fahrenheit. If battery charge is low, disconnect terminal wires and recharge on an automotive type charger following instructions provided with the charger. For best results, slow charge 1 amp for 10 hours or if time does not permit, fast charge at 3 amp rate for 4 hours. Always disconnect the battery negative terminal first and reconnect it last. Keep the red boot over the positive terminal!

## BATTERY STORAGE

Recharge the battery once each month during the off season storage period. To prevent damage due to exposed cells, remove the wet cell type battery before standing the mower on end during storage. Store the battery in a vented area preferably where temperatures remain above 32 degrees Fahrenheit, but not too warm. DO NOT store a battery on a concrete floor.

## STORAGE PROCEDURE

If desired, stand the mower on end during off-season storage provided the following steps are taken beforehand:

1. Remove wet cell type battery (see BATTERY STORAGE).
2. Thoroughly clean surfaces and lubricate machine (See LUBRICATION SERVICES).

3. Drain fuel from tank and close vent on the fuel filler cap.

4. Service engine for storage as described in the engine owner's manual.

After storing on end, the following steps are required to prepare the engine for operation again. Turn the IGNITION SWITCH off and pull the ROPE START HANDLE slowly. If excessive resistance is felt or if the engine refuses to rotate, remove the spark plug and pull handle again to clear cylinder of oil. Clean and reinstall the spark plug.

## MOWING HINTS

Before starting to mow, move the ENGINE CONTROL lever forward (into the FAST position). Set the TRANSMISSION SHIFT lever in a mid range setting and the CUTTING HEIGHT lever in a raised position.

Then, experiment and adjust cutting height and forward speed until the mower is functioning best for your particular conditions.

**NOTE:** The engine is designed to be run at "FULL THROTTLE" while the grass is being cut.

If the ground is dry and dusty, and grass is sparse, be aware that the vacuum action of the blade will create a dust storm! Also, when fertilizing the lawn with a dry-type fertilizer, don't use the mower until after there has been a shower or the lawn has been sprinkled.

Changing your mowing pattern from time to time creates a smoother cut lawn. Finely chopped clippings add nutrients to the soil to promote grass growth. However, if accumulation becomes too heavy, matting develops and thatch is formed which prevents breathing, holds excessive moisture, and can destroy root structure.

## SNAPPER TOTAL PROTECTION

### FULL TWO-YEAR WARRANTY

#### - NON-COMMERCIAL USERS -

FOR TWO YEARS FROM THE ORIGINAL PURCHASE DATE OF THIS PRODUCT FOR YOUR NON-COMMERCIAL USE, SNAPPER POWER EQUIPMENT, THROUGH A SNAPPER DEALER, WILL REPAIR THE PRODUCT FREE OF CHARGE, IF IT DOES NOT WORK FOR ANY REASON.

RETURN THE PRODUCT TO A SNAPPER DEALER FOR REPAIR UNDER THIS WARRANTY.

YOU PROVIDE THE USUAL MAINTENANCE AS SPECIFIED IN THE OWNER/OPERATOR MANUALS.

THERE IS NO OTHER EXPRESS WARRANTY.

LIABILITY FOR INCIDENTAL AND CONSEQUENTIAL DAMAGES ARE EXCLUDED. SOME STATES DO NOT ALLOW THE EXCLUSION OF INCIDENTAL OR CONSEQUENTIAL DAMAGES, SO THIS EXCLUSION MAY NOT APPLY TO YOU.

THIS WARRANTY GIVES YOU SPECIFIC LEGAL RIGHTS, AND YOU MAY ALSO HAVE OTHER LEGAL RIGHTS WHICH VARY FROM STATE TO STATE AND COUNTRY TO COUNTRY.

### LIMITED WARRANTY

#### - COMMERCIAL USERS -

FOR NINETY (90) DAYS FROM THE ORIGINAL PURCHASE DATE OF THIS PRODUCT FOR YOUR COMMERCIAL USE, SNAPPER POWER EQUIPMENT, THROUGH AN AUTHORIZED SNAPPER DEALER, WILL REPAIR THE PRODUCT FREE OF CHARGE, IF IT IS FOUND TO BE DEFECTIVE IN MATERIAL OR WORKMANSHIP.

RETURN THE PRODUCT TO A SNAPPER DEALER FOR REPAIR UNDER THIS WARRANTY.

YOU PROVIDE THE USUAL MAINTENANCE AS SPECIFIED IN THE OWNER/OPERATOR MANUALS.

THERE IS NO OTHER EXPRESS WARRANTY.

IMPLIED WARRANTIES, INCLUDING THOSE OF MERCHANTABILITY AND FITNESS FOR A PARTICULAR PURPOSE, ARE LIMITED TO NINETY (90) DAYS FROM THE ORIGINAL PURCHASE DATE. SOME STATES DO NOT ALLOW LIMITATIONS ON HOW LONG AN IMPLIED WARRANTY LASTS, SO THE ABOVE LIMITATION MAY NOT APPLY TO YOU.

LIABILITY FOR INCIDENTAL AND CONSEQUENTIAL DAMAGES ARE EXCLUDED. SOME STATES DO NOT ALLOW THE EXCLUSION OR LIMITATION OF INCIDENTAL OR CONSEQUENTIAL DAMAGES, SO THE ABOVE EXCLUSION MAY NOT APPLY TO YOU.

THIS WARRANTY GIVES YOU SPECIFIC LEGAL RIGHTS, AND YOU MAY ALSO HAVE OTHER LEGAL RIGHTS WHICH VARY FROM STATE TO STATE AND COUNTRY TO COUNTRY.

PLEASE COMPLETE THE ATTACHED SNAPPER PRODUCT REGISTRATION CARD AND PROMPTLY MAIL IT TO SNAPPER POWER EQUIPMENT, McDONOUGH, GEORGIA 30253.

## SNAPPER POWER EQUIPMENT

McDonough, GA., 30253 U.S.A.

