

Simplicity®

Replacement Parts/Maintenance Items

Available From Your Simplicity Dealer

Listed below are part numbers for the more common replacement parts. Use the order form at the back of the manual to order a complete, illustrated parts manual. Only genuine *Simplicity* replacement parts will assure optimum performance and safety. Do not attempt repairs or maintenance unless proper procedures and safety precautions are followed. For assistance in any area, see your dealer.

REPLACEMENT PARTS

QTY. PER UNIT	DESCRIPTION	PART NUMBER
2	Blade, 36" Mower	1657589
3	Blade, 42" Mower	1656147
1	Pin, Mower Lift Chain	1960296
1	Washer, Mower Lift Chain	1921319
1	Pin, Quick, Mower Lift Chain	1960221
1	Belt, 42" Mower	1678241
1	Belt, 36" Mower	1664644
1	Washer, PTO Rod	1917642
1	Pin, PTO Rod	1918196
2	Pin, Hitch, Straight	105249
2	Pin, Hitch, Safety	176012
1	Belt, Rider Drive, Traction	1678354
1	Keys (2 Keys w/Ring)	122203
2	Interlock Switch, PTO & Trans.	1679932
1	Interlock Switch, Seat	1700636
1	Battery	1685215

MAINTENANCE ITEMS

DESCRIPTION

PART NUMBER

• Simplicity Engine Oils (Your dealer has 1 qt. cans) SAE 5W-30 SF/CD (Cold Weather 30° & under)	Case of 12 Qts. 1685576
SAE 15W40 SF/CD (14° and above)	Case of 12 Qts. 1685554
• Touch-Up Paints	
Classic Orange - 13 Oz. Spray Can	1685558
White - 13 Oz. Spray Can	103049
Classic Orange/White ½ Oz. of Each - Daubber Pack	1685563
• Grease Gun Kit w/8 Oz. Grease Tube Replacement 8 Oz. Grease Tube for above	1685510 103077
• Tire Sealant - Stops Tire Leaks. Prevents Flats.	
11 Oz. Tube	1685523
12 Pack of 11 Oz. Tubes	1685537
24 Case of 11 Oz. Tubes	1685525
• Designer Seat Cover	
For Seats 15" W x 16" L x 8½" H	1685540
For Seats 20" W x 18" L x 11" H	1685541
• Gas Can - No Tip Design. Durable Polyethylene. Easy Pour Spout	
2½ Gallon	1685555
5¼ Gallon	1685556

Contents

REPLACEMENT PARTS	Inside Front Cover	
SAFETY RULES		2
DECALS		4
OPERATION		6
Controls		6
Check Before Starting		7
Interlock Switches		7
Starting and Stopping		7
Selecting Gears & Engine Speed		8
Mowing Pattern & Tips		8
NORMAL CARE		10
Normal Care Schedule		10
Storage		11
Lubrication		11
Tire Pressure		13
Battery Maintenance		14
Servicing the Mower Blades		15
Mower Removal		15
Sharpening & Balancing		16
Blade Installation		17
Mower Installation		17
TROUBLESHOOTING		19
Battery Replacement		23
Belt Replacement		24
ADJUSTMENTS		26
Seat Adjustment		26
Mower Leveling		27
Belt Stops		27
Cutting Height		28
Chain Adjustment		28
Clutch-Brake Adjustment		28
Mower PTO		29
OPTIONAL EQUIPMENT		30
PARTS MANUAL AVAILABLE		31
SPECIFICATIONS	Inside Back Cover	

Safety Rules



Read these safety rules and follow them closely. Failure to obey these rules could result in loss of control of vehicle, severe personal injury to yourself or bystanders, or damage to property or equipment. The triangle  in the text signifies important cautions or warnings which must be followed.

- Know the controls and how to stop quickly. READ THIS OPERATOR'S MANUAL and instructions furnished with attachments.
- Do not allow children to operate the machine. Do not allow adults to operate it without proper instruction.
- Do not carry passengers. Do not mow when children and others are around.
- Clear the work area of objects (wire, rocks, etc.) that might be picked up and thrown.
- Disengage all attachment clutches and shift into neutral before attempting to start the engine (motor).
- Disengage power to attachments and stop the engine (motor) before leaving the operator's position.
- Disengage power to attachments and stop the engine (motor) before making any repairs or adjustments.
- Disengage power to attachments when transporting or not in use.
- Take all possible precautions when leaving the vehicle

unattended, such as disengaging the power-take-off, lowering the attachments, setting the parking brake, stopping the engine, and removing the key.

- Do not stop or start suddenly when going uphill or downhill. Mow up and down the face of steep slopes; never across the face.
- Reduce speed and exercise extreme caution on slopes and in sharp turns to prevent tipping or loss of control. Be especially cautious when changing direction on slopes.
- Stay alert for holes, rocks, and roots in the terrain and other hidden hazards. Keep away from drop-offs.
- Do not use machine to pull loads, loss of steering control could occur.
- Use care when carrying loads.
 - a. Limit loads to those you can safely control.
 - b. Do not turn sharply. Use care when backing.
 - c. Use counterweights or wheel weights when suggested in this Operator's Manual or Attachment Operator's Manual.

- Watch out for traffic when crossing or near roadways.
- When using any attachments, never direct discharge of material toward bystanders or allow anyone near the vehicle while in operation.
- Handle gasoline with care — it is highly flammable.
 - a. Use approved gasoline container.
 - b. Never remove the fuel cap of, or add gasoline to, a running or hot engine or an engine that has not been allowed to cool for several minutes after running. Never fill the tank indoors and always clean up spilled gasoline.
 - c. Open doors if the engine is run in the garage — exhaust fumes are dangerous. Do not run the engine indoors.
- Keep the vehicle and attachments in good operating condition, and keep safety devices in place and in working condition.
- Keep all nuts, bolts, and screws tight to be sure the equipment is in safe working condition.
- Never store the equipment with gasoline in the tanks inside a building where fumes may reach an open flame or spark. Allow the engine to cool before storing in any enclosure.
- To reduce fire hazard, keep the engine free of grass, leaves, or excessive grease.
- The vehicle and attachments should be stopped and inspected for damage after striking a foreign object, and the damage should be repaired before restarting and operating the equipment.
- Do not change the engine governor settings or overspeed the engine.
- When using the vehicle with mower, proceed as follows:
 - a. Mow only in daylight or in good artificial light.
 - b. Never make a cutting height adjustment while the engine (motor) is running if the operator must dismount to do so.
 - c. Shut the engine (motor) off when removing the grass catcher or unclogging chute.
 - d. Check the blade mounting bolts for proper tightness at frequent intervals.
- Under normal usage, the grass catcher bag material is subject to deterioration and wear. Check bag frequently for deterioration and wear and replace worn bags. Check that replacement bags comply with the original manufacturer's recommendations or specifications.
- Disengage power to mower before backing up. Do not mow in reverse unless absolutely necessary and then only after observation of the entire area behind the mower.

Decals

WARNING

- DO NOT STOP OR START SUDDENLY WHEN OPERATING UPHILL OR DOWNHILL.
- MOW UP AND DOWN THE FACE OF STEEP SLOPES; NEVER ACROSS THE FACE.
- SELECT SLOW GROUND SPEED BEFORE DRIVING ONTO A SLOPE.
- NEVER OPERATE ON SLOPES GREATER THAN 16° WHICH IS A RISE OF 3 FEET (0.91 METERS) VERTICALLY IN 10 FEET (3.1 METERS) HORIZONTALLY.
- USE A REAR WEIGHT KIT ON SLOPES GREATER THAN 8° WHICH IS A RISE OF 1.5 FEET (0.45 METERS) VERTICALLY IN 10 FEET (3.1 METERS) HORIZONTALLY.

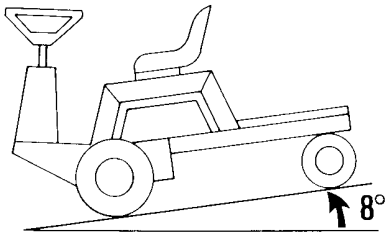

USE REAR WEIGHT KIT

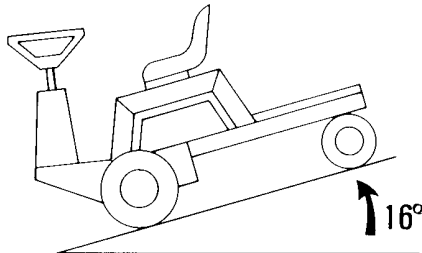

DO NOT OPERATE!

P.T.O. NEUTRAL

NO RIDERS

DANGER

- ROTATING CUTTING BLADE**
- DO NOT PUT HANDS OR FEET UNDER MOWER DECK WHILE BLADE IS ROTATING.

DANGER

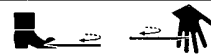

- ROTATING CUTTING BLADE**
- DO NOT OPERATE MOWER WITHOUT DEFLECTOR OR ENTIRE GRASS CATCHER IN PLACE.

5
4
3
2
1

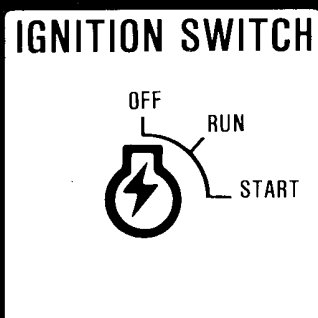
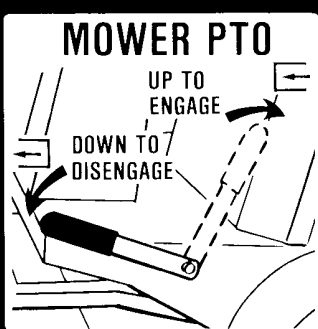

CAUTION

TO AVOID POSSIBLE INJURY

- READ OPERATOR'S MANUAL(S).
- KNOW LOCATION AND FUNCTION OF ALL CONTROLS.
- KEEP SAFETY DEVICES (GUARDS, SHIELDS, AND SWITCHES) IN PLACE AND WORKING.
- REMOVE OBJECTS THAT COULD BE THROWN BY BLADE.
- DO NOT MOW WHEN CHILDREN AND OTHERS ARE AROUND.
- NEVER CARRY CHILDREN.
- ALWAYS LOOK BEHIND MACHINE BEFORE BACKING.
- DO NOT MOW WHERE MACHINE COULD TIP OR SLIP.
- IF MACHINE STOPS GOING UPHILL, STOP BLADE AND BACK SLOWLY DOWN.
- DO NOT MOW IN REVERSE UNLESS ABSOLUTELY NECESSARY.
- WHEN LEAVING MACHINE REMOVE KEY AND SET PARKING BRAKE.

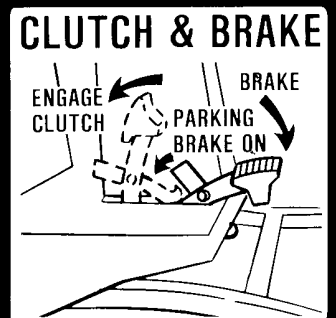
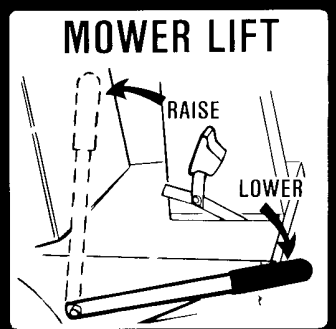

Operation

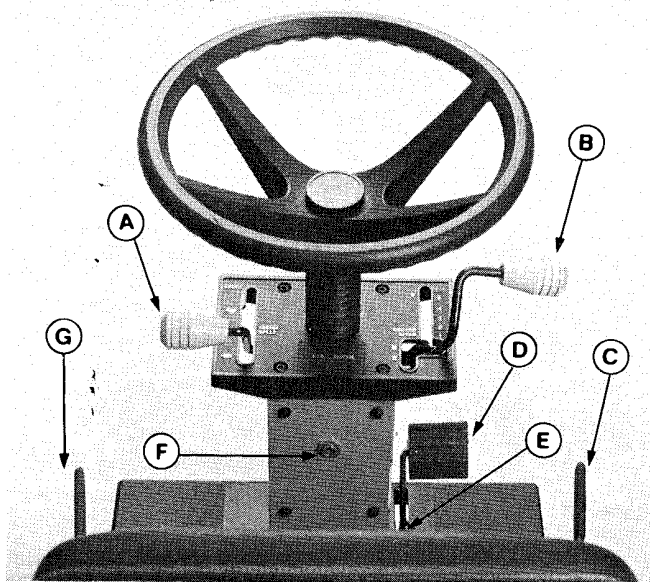

Figure 1. Controls

ITEM	NAME	FUNCTION
A	Engine Speed Control Lever	Controls engine speed. Push fully forward to activate choke.
B	Gear Shift Lever	Controls ground speed. Select reverse, neutral or 5 forward speeds.
C	Mower Lift Lever	Raises mower for transport. Pull up and hold to raise mower.
D	Clutch-Brake Pedal	Press down to disengage drive and engage brake. Release to engage drive.
E	Parking Brake Lever	Locks brake. Depress pedal, then latch lever over edge.
F	Ignition Switch	Starts and stops engine.
G	Mower PTO Lever	Engages mower. Pull up to begin mowing. Push down to disengage mower.



WARNING

Never allow passengers to ride on the unit.

CHECKS BEFORE STARTING

1. Check that gas tanks (one on each side) are full. (If one tank is empty, either fill it, or shut off the valve on bottom of tank.)
2. Check engine oil level and add if necessary. Refer to engine Owner's Manual for recommendations.



WARNING

Never add gasoline when engine is hot or running.

3. Make sure either deflector or grass collection system is in place.
4. Check for loose nuts, screws, bolts, oil leaks, gasoline leaks, etc.
5. Make sure the mower is desired cutting height.

INTERLOCK SWITCHES

A switch under the seat will stop the engine if the operator leaves the seat when PTO is engaged and/or transmission is in gear. Also, to start engine, the operator must be in seat, the gear shift lever must be in neutral and the mower PTO disengaged.

STARTING AND STOPPING

1. Before using this mower for the first time, the owner should operate in an open area, without mowing, to become accustomed to the unit. The unit is steered with the rear wheels, which allows very quick, tight turns. The left side of the mower can be used to trim close to objects in the lawn.
2. Make sure mower is disengaged and gear shift lever is in neutral.
3. Place engine speed control into choke position unless engine is hot.
4. Turn the key to start and release when engine starts. Move lever out of choke position as engine warms.
5. Make sure desired direction is clear of objects, people and animals.
6. Place gear shift lever in desired gear (see Selecting Gears and Engine Speed).
7. When ready to mow, pull the mower PTO lever up to engaged position.
8. Release the clutch-brake pedal to travel. Adjust engine speed as desired.
9. **To stop**, depress the clutch-brake pedal. Depressing the pedal halfway will disengage the drive; depressing the pedal completely will apply the brake.

Operation

10. **Before leaving operator's position**, set the parking brake and disengage the mower PTO. (The parking brake is shown set in figure 2.) Set the engine speed control to SLOW and allow the engine to idle for 20 seconds. Turn the key to OFF and remove it. Wait for moving parts to stop.
11. Clean all dirt and grass from the mower and rider. Be sure to clean the engine and transmission compartment. Allow engine to cool before touching engine parts.



WARNING

To reduce fire hazard, keep the engine, rider and mower free of grass, leaves and excess grease.



WARNING

Do not stop or start suddenly when operating uphill or downhill. Mow up and down the face of steep slopes; never across the face. Select slow ground speed before driving onto a slope. Never operate on slopes greater than 16° which is a rise of 3 feet (0.91 meters) vertically in 10 feet (3.1 meters) horizontally. Use a rear weight kit on slopes greater than 8° which is a rise of 1.5 feet (0.45 meters) vertically in 10 feet (3.1 meters) horizontally.



CAUTION

During operation shift gears only when clutch-brake pedal is depressed.

SELECTING GEARS & ENGINE SPEED

Most mowing is done in second, third or fourth gear with engine speed between 3/4 and full speed. If the terrain is rough, hilly, or sloping use lower gear. If the grass is wet or over three inches (76 mm) high, use full engine speed (with lower gear) so the mower will have enough power to cut the grass. Use lower gears to mow around gardens, buildings, etc. **Shift gears only with clutch-brake pedal depressed.**

MOWING PATTERN & TIPS

For the first use of the mower choose a smooth level area. Cut long straight strips overlapping slightly.

The size and type of area to be mowed determines the best mowing pattern to use. Obstructions such as trees, fences and buildings must also be considered. Where possible, make one or two passes in a clockwise direction around the outside of the area to keep cut grass off fences and walks. The remainder of the mowing should be done in a counterclockwise direction so the clippings are dispersed on the cut area.

Most lawns should be mowed to keep the grass approximately two to three inches (50 to 76 mm) high. Best results are obtained by cutting often and not too short. To help keep a green lawn, never mow more than one third of the height of the grass, or a maximum of one inch (25 mm), in one mowing. For extremely tall grass, set the cutting height at maximum for the first pass, and then reset to the desired height and mow again.

For best appearance, grass should be cut in the afternoon or early evening (in daylight) when it is free of external moisture.

Where possible, change patterns occasionally to eliminate matting, graining or a corrugated appearance.

NORMAL CARE

Care Required	See Page	Before First *Use	Every Five Hours	Every 25 Hours	Every 50 Hours Or Yearly
Check for loose hardware, oil leaks, etc.	—	•	•		
Lubricate rider and mower	11			•	
Check fluid level in battery**	14	•	•		
Check tire pressures	13	•		•	
Change oil*	Eng. Man.			•	
Service air cleaner	Eng. Man.			•	
Check engine oil level	Eng. Man.	•	•		
Clean the cooling system**	Eng. Man.				•
Clean battery	14				•
Service the blade	15				•
Service spark plug	Eng. Man.				•
<p>*Change original engine oil after first 5 hours of operation. **More often in hot (over 85° F; 30° C) weather or dusty operating conditions.</p>					

Normal Care Schedule

STORAGE (30 Days or More)

1. Run tractor engine until it stops from lack of fuel or, use a gasoline stabilizer. This additive, available from your dealer, prevents formation of gum and varnish for up to one year.



WARNING

Never store rider where gasoline fumes may reach an open flame or sparks.

2. Change engine oil. Record the type and weight of oil put in crankcase.
3. Remove the spark plug. Squirt approximately one ounce (30 ml) of engine oil into engine through spark plug hole. Crank engine a few times to distribute oil and then reinstall the spark plug.
4. Lubricate the rider and mower.
5. Check battery fluid level. Battery life will be extended if it is removed and stored in a cool, dry place, fully charged.
6. Clean rider thoroughly. Touch up exposed metal parts with a good quality paint (obtainable from your dealer) or a light film of grease or oil.

LUBRICATION

1. With an oil can, apply a few drops of oil to points indicated with oil can in figures 2 through 8. Oil the drive chain (figure 6) with an approved chain lubricant.
2. With a grease gun, apply one or two shots of lithium based automotive grease to the grease fittings. See figures 7 and 8.

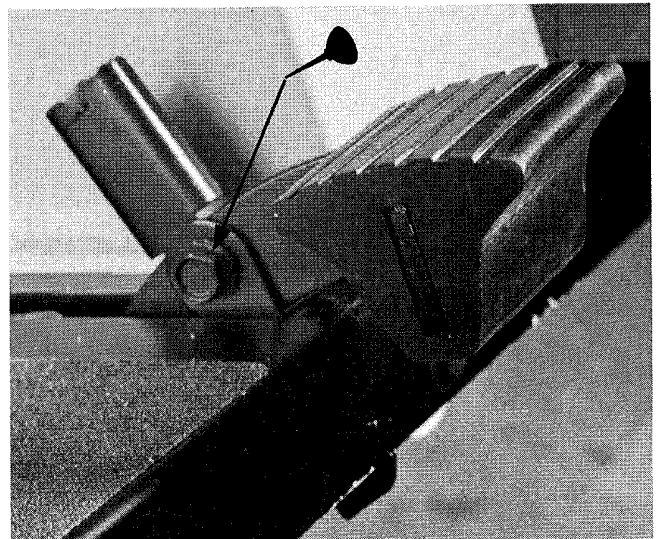

Figure 2. Lube Brake Pedal Pivot Points

Normal Care

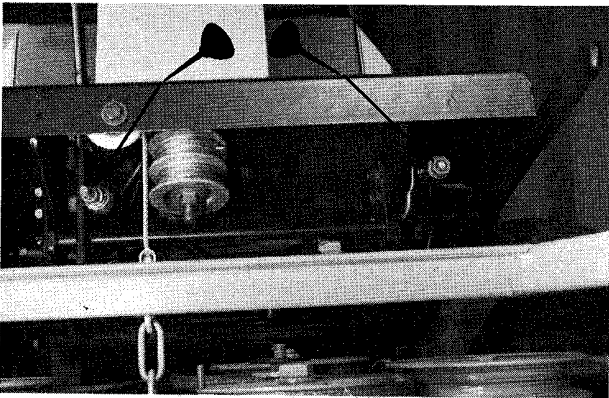

Figure 3. Lube Points Where Rods Contact Other Parts & Lever Pivot Points

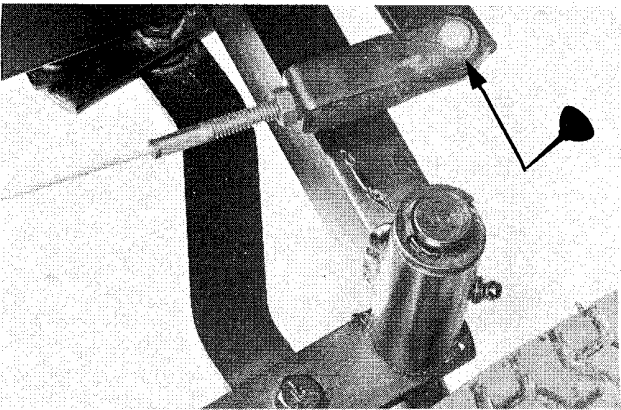

Figure 5. Lube Rear Axle Clevis and Pivot Points

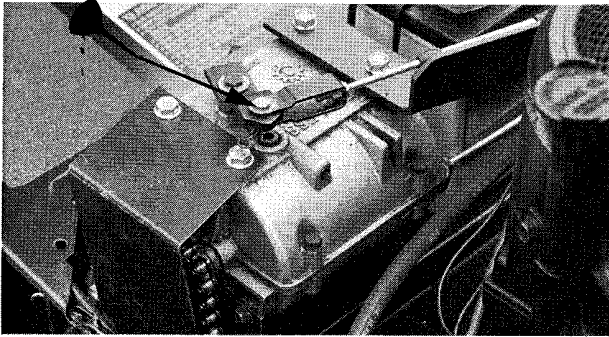

Figure 4. Lube Transmission Control Pivot Points

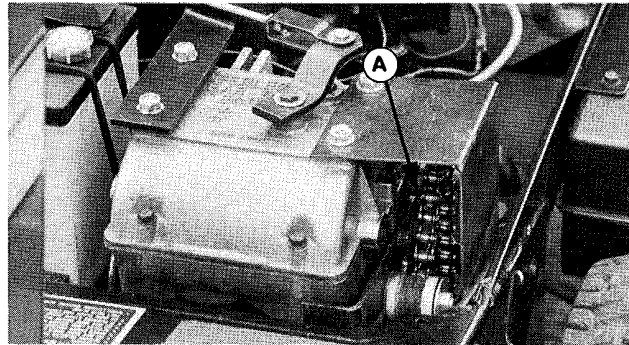

Figure 6. Chain
A. Chain

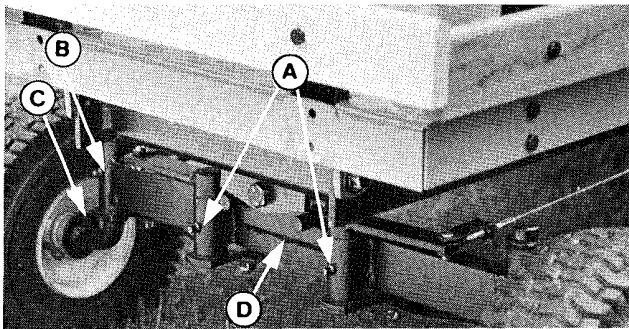

Figure 7. Grease Fittings

- A. Axle Pivot
- B. Spindles (One fitting on each side)
- C. Wheels (One fitting on each side)
- D. Axle Pivot (Under Weight)

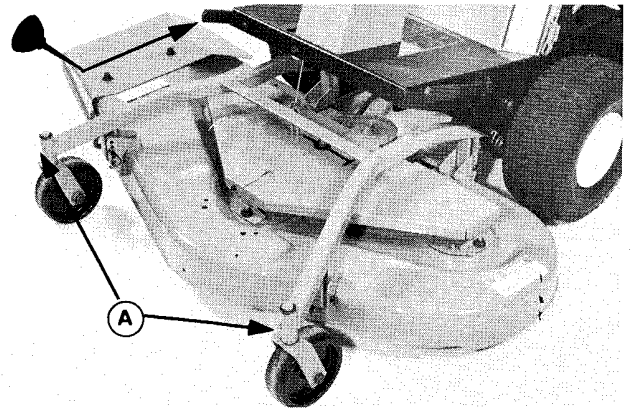

Figure 8. Grease Fittings & Lift Lever Pivot Points in Frame

CHECK TIRE PRESSURE

Make sure the pressure in the front tires is 8 to 12 psi and the air pressure in the rear tires is 18 to 22 psi. Use a gauge with one-pound markings. Unequal or improper tire pressure can cause an uneven cut.

Normal Care

BATTERY MAINTENANCE

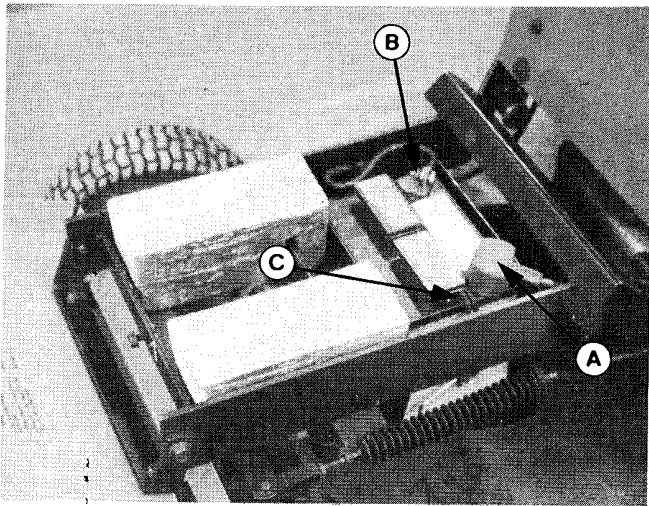

Figure 9. Battery

- A. Positive Terminal**
- B. Negative Terminal**
- C. Straps**

WARNING

Be careful when handling the battery. Avoid spilling electrolyte. Keep flames and sparks away from the battery.

WARNING

For your personal safety when removing or installing battery cables, always disconnect the negative cable **FIRST** and reconnect it **LAST**. The positive battery terminal can easily be shorted to the tractor frame by a wrench or other tool if this is not done.

Check Fluid Level

Check the battery fluid level. Wipe dirt from around the caps then remove the caps one at a time. The fluid must be even with the bottom of the split ring. If not, add distilled water. Reinstall the caps. Be sure the cover is in place over positive terminal.

Cleaning Battery and Cables.

1. Disconnect the cables from the battery, negative cable first. A positive "+" sign is stamped on the battery next to the positive terminal. For mfg. no. 1691457 and 1691458, lift rear platform to locate battery (figure 9). For mfg. no. 1691330 and 1691198, the battery is located under the seat deck.

2. Slip the battery straps off, then remove the battery.
3. Clean the battery terminals and cable clamps with a wire brush.
4. Scrub the battery, cable and battery compartment with baking soda and water.
5. Reinstall battery and straps.

6. Connect cables, positive cable first.
7. Coat cable clamps and terminals with grease or petroleum jelly. Be sure to slide cover over positive terminal.

SERVICING THE MOWER BLADES

Mower Removal



WARNING

Do not handle the blade with bare hands. Do not touch the cutting edge.

1. Remove the mower for blade maintenance as follows.
2. Remove the two pins (A, figure 10) and clips (B). Slip a 2" x 4" board under rear edge of mower to make pin removal easier.

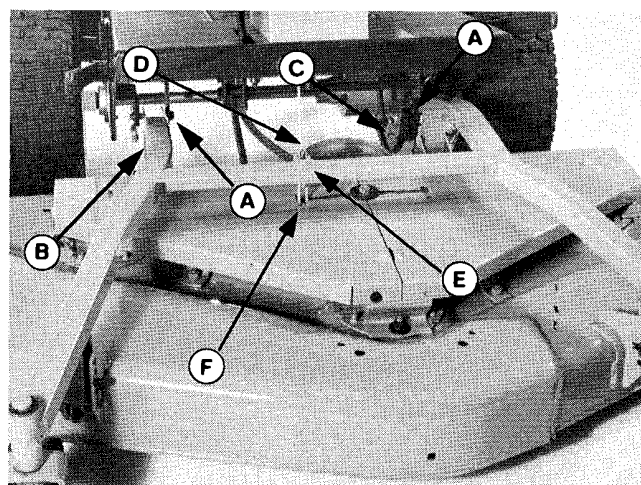

Figure 10.

- | | |
|------------|---------------|
| A. Pin | D. Lift Cable |
| B. Clip | E. Bracket |
| C. PTO Rod | F. Lift Chain |

3. Remove pin and washer to disconnect the PTO lever (C). Remove the clip and pin that secures the lift clevis (D).
4. To slip belt off the engine pulley (C, figure 11A or 11B), loosen the idler pulley belt guide (A).

Normal Care

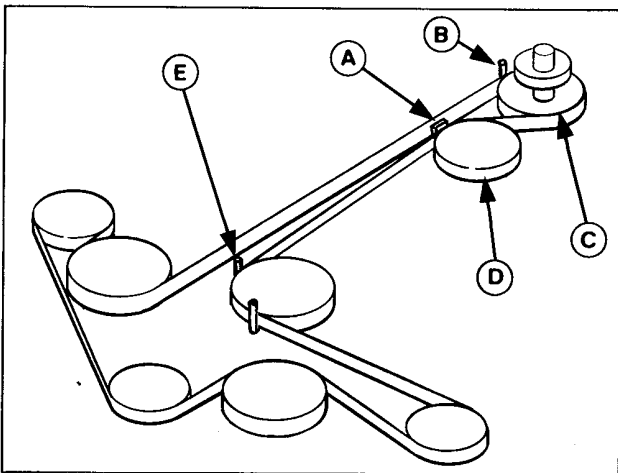

Figure 11A. 42" Mower Belt Pattern

- A. Belt Guide
- B. Belt Stop
- C. Engine Pulley
- D. Idler Pulley
- E. Belt Stop

Sharpening & Balancing

1. To remove a blade, wedge a wood block between blade and housing to prevent rotation. Then, turn capscrew counterclockwise to remove.
2. Use a file to sharpen blade to a fine edge. Remove all nicks and dents in blade edge. If blade is severely damaged it should be replaced.

3. To balance the blade, use a balancing machine or the following procedure. Drive a small nail into the side of a workbench or other vertical surface. Lubricate the nail with a drop of oil. Center the blade center hole on the nail. A balanced blade will remain level. File material off heavier end of blade until it is balanced.

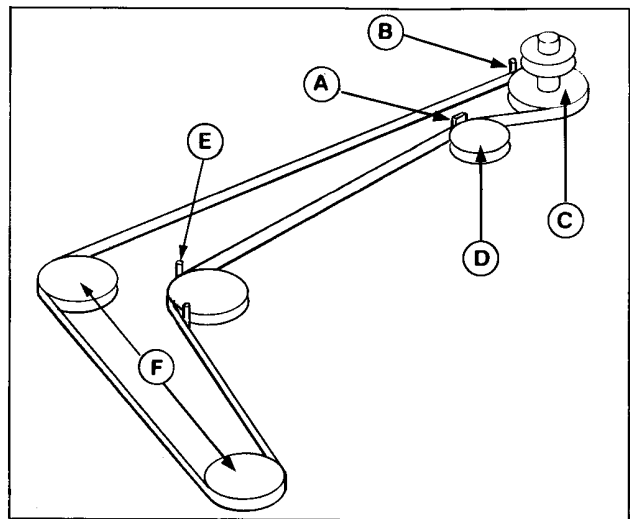

Figure 11B. 36" Mower Belt Pattern

- A. Belt Guide
- B. Belt Stop
- C. Engine Pulley
- D. Idler Pulley
- E. Belt Stop
- F. Arbor Pulleys

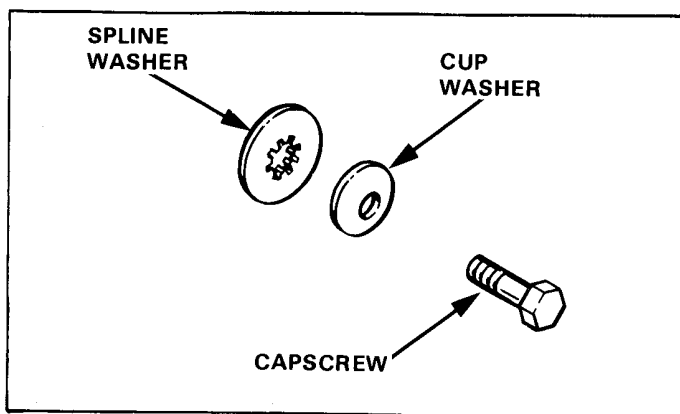

Figure 12. Blade Hardware

Blade Installation

1. Reinstall the blade(s) with the tabs pointing upward. Install the spline washer, cup washer, and capscrew (see figure 12). Be sure the splines on the spline washer are engaged with the shaft splines. Be sure cup washer is installed with the concave side up.
2. To tighten the capscrew, wedge a wood block between blade and housing to prevent blade from turning. Torque the capscrew to 55 ft. lbs.

MOWER INSTALLATION

1. After servicing blade, re-install mower as follows.
2. Slip belt onto the engine pulley. Refer to figure 11A or 11B for pattern. Be sure there are no twists in belt.
3. Connect mower to rider with two pins (A, figure 10) and clips (B). Slip a 2" x 4" board under rear edge of deck to make pin installation easier.
4. Insert PTO rod (A, figure 13) through bracket (E) and brake rod (D) and install washer (C) and pin (B).
5. Place the lift chain (F, figure 10) and lift cable clevis into the bracket (E). Insert pin through bracket, clevis and chain. Then, secure with the clip.
6. Position the belt guide (A, figure 11A or 11B) and belt stops (B and E) 1/16 to 1/8 inch from belt with belt engaged. Tighten securely.

Normal Care

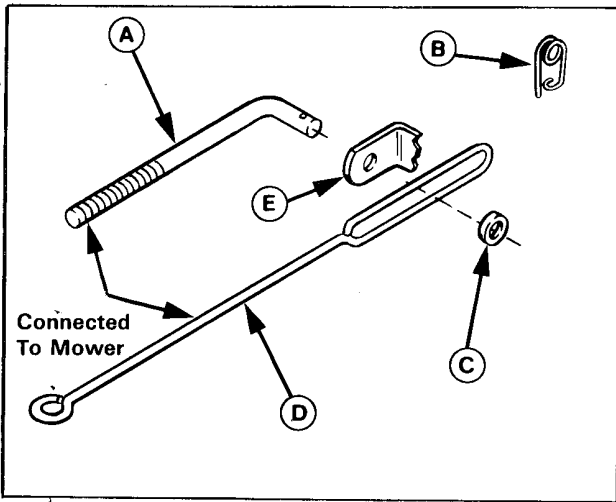

Figure 13.

- A. PTO Rod from Mower
- B. Spring Pin
- C. Washer
- D. Brake Rod
- E. Bracket (Under Rider)

Troubleshooting

CONTENT OF SECTION

This section of the manual provides troubleshooting and repair instructions for the more common and easily corrected problems. For other problems, it is recommended that you contact your dealer.



WARNING

Perform maintenance on the tractor or mower only when the engine is stopped and the parking brake engaged. Always remove the ignition key before beginning the maintenance to prevent accidental starting of the engine.

Problem	Cause/Remedy
1. Engine will not start.	<ul style="list-style-type: none">A. Gear shift lever not in neutral-start position. Shift into neutral.B. Mower engagement lever not disengaged. Disengage fully.C. Out of fuel. Allow engine to cool then refill the fuel tanks. Both tanks must be filled or the empty tank shut off at valve.D. Engine flooded. Move control out of CHOKE.E. Circuit breaker tripped. Wait one minute for automatic reset. Replace if defective (see your dealer).F. Battery terminals require cleaning. See Normal Care section.G. Battery discharged or dead. Recharge or replace.H. Wiring loose or broken. Visually check wiring & replace broken or frayed wires. Tighten loose connections.I. Solenoid or starter motor faulty. Repair or replace.J. Safety interlock switch faulty. Replace if needed (see your dealer.)K. Spark plug faulty, fouled or incorrectly gapped. Clean and gap or replace. See engine manual.L. Water in fuel. Drain fuel & refill with fresh fuel.M. Old stale gas. Drain fuel & replace with fresh fuel.

Troubleshooting

Problem	Cause/Remedy
2. Engine starts hard or runs poorly.	A. Fuel mixture too rich. Clean air filter. Check choke adjustment (engine speed control). See engine manual. B. Carburetor adjusted incorrectly. See engine manual. C. Spark plug faulty, fouled, or incorrectly gapped. Clean and gap or replace See engine manual.
3. Engine knocks.	A. Low oil level. Check/add oil as required. B. Using wrong grade oil. See engine manual
4. Excessive oil consumption.	A. Engine running too hot. Clean engine fins, blower screen and air cleaner. B. Using wrong weight oil. See engine manual. C. Too much oil in crankcase. Drain excessive oil.
5. Engine exhaust is black.	A. Dirty air filter. Clean air filter. See engine manual. B. Check engine speed control adjustment (choke). See engine manual.
6. Engine runs, but rider will not drive.	A. Transmission not in gear. Shift into gear. B. Belt or chain is broken. Replace. Check chain adjustment. (See Adjustments section.) C. Drive belt slips. (See problem and cause below.)
7. Rider drive belt slips.	A. Clutch is out of adjustment. See your dealer. B. Pulleys or belt greasy or oily. Clean as required. C. Belt stretched or worn. Replace with correct belt. D. clutch rod binding in guide. Oil clutch rod.
8. Brake will not hold.	A. Brake is incorrectly adjusted. See your dealer. B. Brake band worn and requires replacement. See your dealer. C. Oil on brakes. Clean or replace brake band. See your dealer.

Problem	Cause/Remedy
9. Rider steers hard.	<ul style="list-style-type: none"> A. Steering linkage is loose. Check and tighten any loose connections. B. Improper tire inflation. Check and correct. C. Spindle bearings dry. Grease spindles.
10. Rider drive belt does not stop when clutch-brake depressed.	<ul style="list-style-type: none"> A. Belt stops out of adjustment. See Adjustment section. B. Clutch out of adjustment. See your dealer.

TROUBLESHOOTING (MOWER)

1. Mower will not raise.	A. Lift cable not attached or damaged. Attach or repair.
2. Mower cut is uneven.	<ul style="list-style-type: none"> A. Mower not leveled properly. See Mower Leveling. B. Tires not inflated equally or properly.
3. Mower cut is rough looking.	<ul style="list-style-type: none"> A. Engine speed too slow. Set for three-fourths to full speed. B. Ground speed too fast. Use lower gear. C. Blades dull and require sharpening. See Normal Care section. D. Mower drive belt slipping. Belt oily or worn. Clean or replace belt as necessary. E. Check PTO Clutch Adjustment. See your dealer.

Troubleshooting

Problem	Cause/Remedy
4. Engine stalls easily with mower engaged.	<ul style="list-style-type: none">A. Ground speed too fast. Use lower gear.B. Carburetor not adjusted properly.C. Cutting height set too low when mowing tall grass. Cut tall grass at maximum cutting height during first pass.D. Discharge chute jamming with cut grass. Cut grass with discharge pointing toward previously cut area.
5. Excessive mower vibration.	<ul style="list-style-type: none">A. Mower blades, arbors, or pulleys are bent. Check and replace as necessary.B. Mower blades are out of balance. Remove, sharpen and balance blades (see Normal Care section).
6. Excessive belt breakage.	<ul style="list-style-type: none">A. Belt tension too tight. Readjust belt tension. See your dealer.B. Bent or rough pulleys. Repair or replace.C. Using incorrect belt. See your dealer.
7. Mower drive belt slips or fails to drive.	<ul style="list-style-type: none">A. Mower drive belt out of adjustment. See your dealer.B. Belt stops out of adjustment. Check.C. Mower drive belt broken. Replace.

BATTERY REPLACEMENT

A battery too weak to start the engine may not need to be replaced. It may, as an example, mean that the charging system is not working properly or that the battery has lost its charge during storage. First check the fluid level and clean the battery. Have the battery recharged if necessary. If there is any doubt about the cause of the problem, see your dealer. If you must replace the battery, remove and install the battery as described in "Clean Battery and Cables."

JUMP STARTING WITH AUXILIARY (BOOSTER) BATTERY

Jump starting is not recommended. First check the battery in "Battery Replacement" above. If jump starting must be done, follow these directions. Both booster and discharged batteries should be treated carefully when using jumper cable. Follow exactly the procedure outlined below, being careful not to cause sparks.



WARNING

Never expose battery to open flame or electric spark — battery action generates hydrogen gas which is flammable and explosive. Do not allow battery acid to contact skin, eyes, fabrics, or painted surfaces. Batteries contain a sulfuric acid solution which can cause serious personal injury or property damage.

NOTE

The positive terminal has a cover. Slide cover away to perform this procedure. Slide cover back over positive terminal for normal operation.

1. Set parking brake and place transmission in "NEUTRAL".
2. Remove vent caps from both the booster and the discharged batteries. Lay a cloth over the open vent wells on each battery. These two actions help reduce the explosion hazard always present in either battery when connecting a "live" battery to a "dead" battery.
3. Attach one end on one jumper cable to the positive terminal of the booster battery (identified by a red color, "+" or "P" on the battery case, post or clamp) and the other end of same cable to positive terminal of discharged battery.
4. Attach one end of the remaining cable to the negative terminal (black color, "-" or "N") of the booster battery, and the other end to a bare metal surface on the frame of your rider AWAY FROM the battery compartment (do not connect directly to negative post of dead battery). Take care that clamps from one cable do not inadvertently touch the clamps on the other cable. Do not lean over the battery when making the connection.

Troubleshooting

5. The rider with discharged battery should now start.

Reverse the jump starting procedure exactly to remove the jumper cables. Then reinstall the vent caps and throw the cloths away as they may have corrosive acid on them.



WARNING

Any procedure other than the above could result in: (1) personal injury caused by electrolyte squirting out of the battery vents, (2) personal injury or property damage due to the battery explosion, (3) damage to the charging system of the booster vehicle or the other immobilized vehicle.

Do not attempt to jump start a vehicle having a frozen battery because the battery may rupture or explode. If a frozen battery is suspected, examine all fill vents of the battery. If ice can be seen, do not attempt to start with jumper cables.

BELT REPLACEMENT



WARNING

Before starting belt replacement, place the rider on a level surface. Stop the engine and remove the key to prevent startup.

Mower Belt

1. Loosen the belt guide on the idler pulley, and slip the belt off the engine pulley.
2. For the 42" mower remove the two belt covers (A, figure 14A) by removing nuts and washers at four locations (B) and one screw (C). For the 36" mower, remove the two screws at each end of belt cover (A, figure 14B).

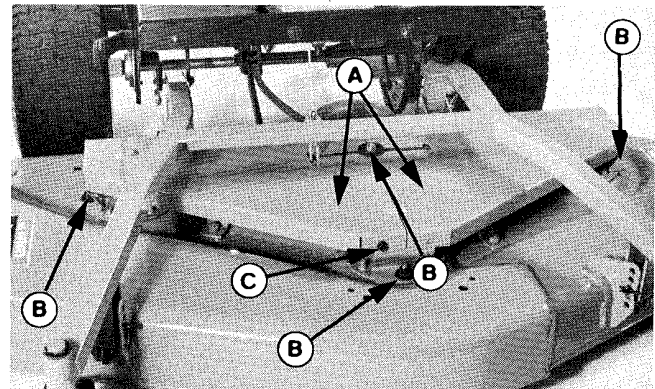

Figure 14A. Belt Covers (42" Mower)

- A. Belt Covers
- B. Nut and Washer
- C. Screw

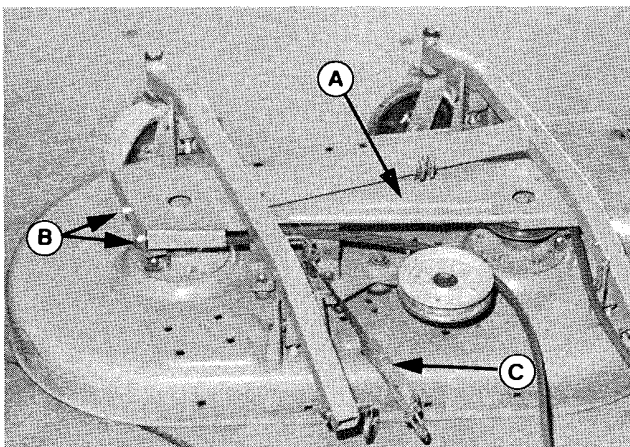

Figure 14B. Belt Cover (36" Mower)

- A. Belt Cover
- B. Screw
- C. Spring, Mower PTO

3. Remove belt from pulleys (figure 15) and install new belt, routing as shown. See belt pattern in figure 11A or 11B on page 16.
4. Slip the belt onto the idler pulley and engine pulley (figure 11A or 11B.)
5. Engage the PTO lever and adjust the mower belt stops (figure 15) and idler pulley belt guide (figure 11A or 11B) 1/16 to 1/8 inch from belt and tighten.

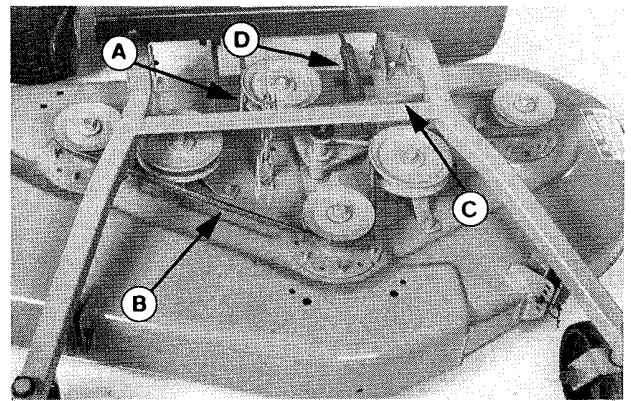

Figure 15. Mower Belt (42" Mower Shown)

- A. Belt Stops
- B. Belt
- C. Belt Brake Location
- D. Spring, Mower PTO

6. Notice the brake location (C, figure 15). Be sure the belt is located so that it is trapped between fixed bracket and the PTO rod bracket when PTO lever is placed in disengaged position.
7. Reinstall the belt covers (step 2). The covers act as belt guides. When installed, there should be clearance between covers and belt when engaged.

Rider Belt

1. To provide slack in the belt, set the parking brake.

2. Slip the belt off the pulleys (figure 16) loosening the belt guide as necessary.
3. Install the new belt as shown in figure 16, making sure there are no twists in the belt.
4. Release the parking brake to provide belt tension. Then position the belt guide 1/16 to 1/8 inch from belt and tighten.
5. Perform Clutch-Brake Adjustment in Adjustment section.

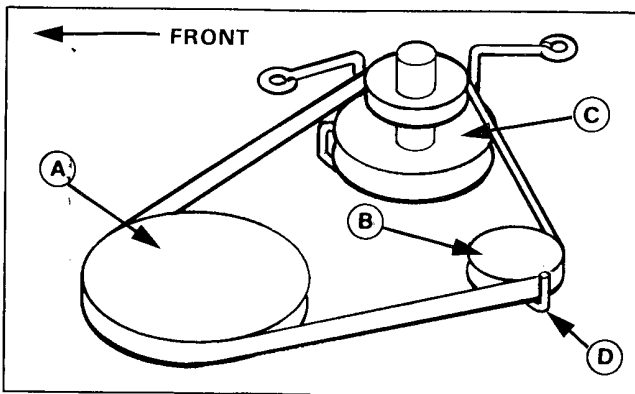

Figure 16.

A. Transmission Pulley
B. Idler Pulley

C. Engine Pulley
D. Belt Stop

Adjustments

SEAT ADJUSTMENT

The seat can be moved forward or back for operator comfort. Loosen the four screws (A, figure 17) and move the seat to the desired position. Tighten the screws.

The springs (B) can be moved to forward holes for lighter operator. Pull up out of holes to relocate springs.

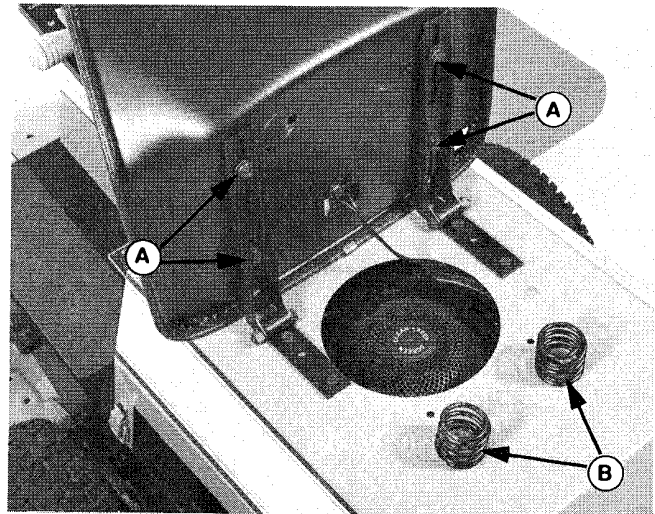

Figure 17. Seat Adjustment

A. Screws
B. Springs

MOWER LEVELING

**WARNING**

During leveling check, remove ignition key, then remove spark plug wire and fasten it away from the spark plug.

NOTE

If the cut is uneven, the mower may need leveling. Unequal or improper tire pressure may also cause an uneven cut.

1. Park the rider on a level surface. Check measurements with mower belt engaged.
2. Make sure that the mower does not rock from side-to-side. All four leveling bolts (A, figure 18) should bear weight from spacers (E, figure 18).
3. Turn the blades side-to-side, and measure from outside tips of blade to ground. If there is more than 1/8 inch difference, raise or lower one side of the mower. To do this, turn in, or out, the leveling bolt at front (A, figure 18) and the leveling bolt at rear bracket (B). Be sure to turn both bolts the same number of turns. Recheck the measurement, then go to step 3 to check front-to-back leveling.

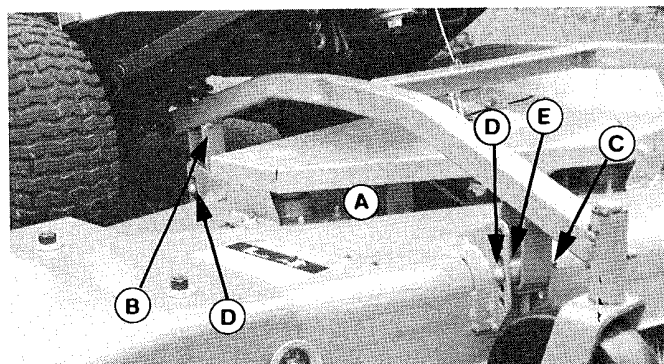

Figure 18. Mower Leveling

A. Leveling Bolt, Right Front
B. Bracket, Rear

C. Clips
D. Pins

E. Spacer

4. Turn the blades front-to-back. Measure the distance to the ground from the front tip of the left blade, and from the rear tip of the right blade. With the operator in seat, the measurements should be within 1/8 inch. With seat empty, the rear should be 1/8 inch higher. To adjust, turn both front leveling bolts or turn both rear leveling bolts. Turn bolts in to raise or out to lower. Be sure to turn both bolts equally.

BELT STOPS

Belt stops should be adjusted 1/16 - 1/8 inch from belt when belt is engaged.

Adjustments

CUTTING HEIGHT

To change the cutting height of the mower, remove four clips (C, figure 18) and move pins (D) to a different hole. The pins must be in corresponding holes at all four locations so the cut will be even.

CHAIN ADJUSTMENT

If there is too much slack in the chain, it can be adjusted. Remove the cover (B, figure 19) by removing two screws (A). Loosen the capscrew and nut which hold the spacer in slot. Move the spacer toward the chain to tighten then tighten the capscrew and nut. Do not adjust chain so it is tight; only remove excess slack.

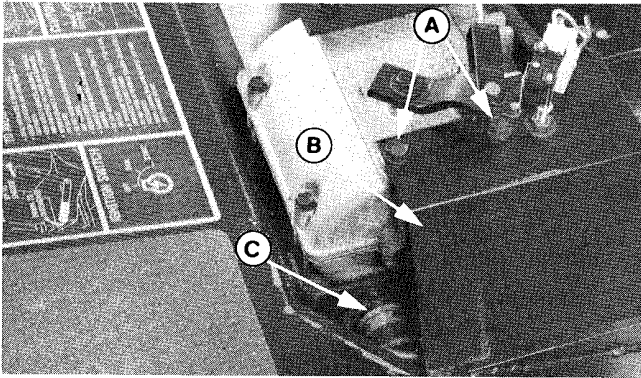

Figure 19. Chain Adjustment

A. Screws B. Cover C. Spacer

CLUTCH-BRAKE ADJUSTMENT

1. Release parking brake.
2. The clutch rod spring (A, figure 20) should measure 2 to 2 1/8" along the long side. To adjust, tighten or loosen the nut (B).
3. Pull the brake rod (C, figure 20) toward front as far as possible. Tighten or loosen the nut (D) to achieve a gap of 3/8 inch between rear surface of nut and the guide that rod extends through.

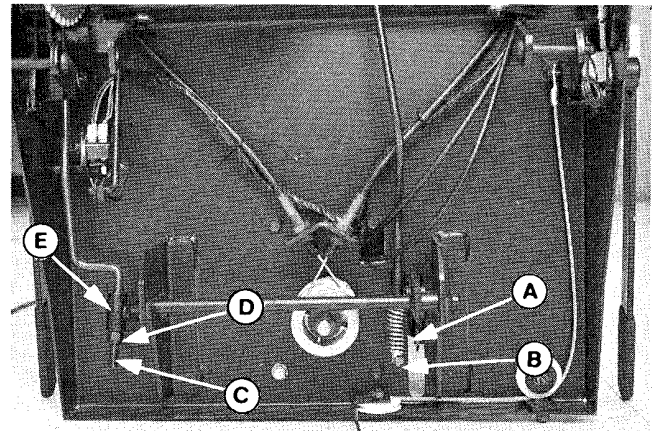

Figure 20. (Viewed from underneath front of rider.)

A. Spring, Clutch Rod

B. Nut, Clutch Rod

C. Brake

D. Nut, Brake Rod

E. Guide

MOWER PTO ADJUSTMENT

1. Locate the mower PTO spring on the PTO rod. For 36" mower, see item C, figure 14B, on page 25. For 42" mower, see item D, figure 15, on page 25. For the 42" mower, remove left-hand belt cover, if desired, for ease of access.
2. When the mower PTO lever is engaged, the spring length should measure 4-3/4 inch as shown in figure 21 or 22, next page. To adjust the 36" mower, go to step 3. To adjust 42" mower, go to step 4.

36" Mower

3. Disengage the mower PTO lever. Locate the two nuts on PTO rod in front of the spring. Loosen the outer nut so inner nut can be adjusted. Tighten nuts onto rod to increase measurement or back off rod to decrease. Engage PTO lever to re-check measurement. When 4-3/4" measurement is attained with lever engaged, tighten the outer nut against the inner nut. This completes adjustment for the 36" mower.

42" Mower

4. Disengage the mower PTO lever. Disconnect the PTO rod by removing pin (D, figure 22). Push the PTO rod forward to expose the nuts which are inside the spring. Loosen outer nut so inner nut can be adjusted. Tighten nuts onto rod to increase measurement or back off rod to decrease. Engage PTO lever to re-check

measurement. When 4-3/4" measurement is attained with lever engaged, tighten the outer nut against the inner nut. Go to step 5.

42" Mower

5. Reinstall the belt covers with nuts and washers at four locations (B, figure 14A) and one screw (C). Notice that channels inside covers act as belt guides. There should be clearance between covers and belt when PTO is engaged.

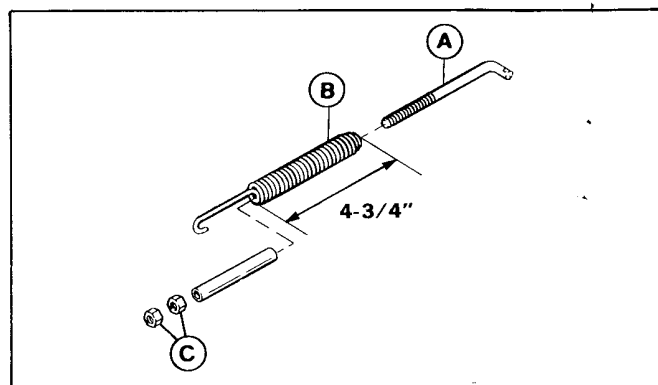
**Figure 21. PTO, 36" Mower**

- A. PTO Rod
- B. Spring
- C. Nuts

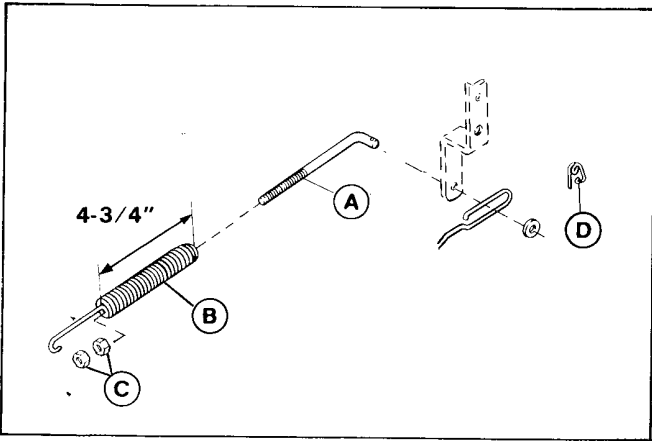

Figure 22. PTO, 42" Mower

- A. PTO Rod
- B. Spring
- C. Nuts
- D. Pin

Optional Equipment

See your dealer to purchase these items.

Attachments

- Woodside Transporter
- Mower Vacuum System
- Deluxe Twin Catcher
- Steel Tilt-Hopper
- Hi-Side Kit
- Dethatcher
- Rotary Spreader
- Liquid Sprayer

Accessories

- Deluxe Seat
- Horn
- Halogen Headlight
- Hour Meter
- Counterweight (rear)
- Hubcaps

PARTS MANUAL AVAILABLE

Simplicity Parts Manuals are fully illustrated. All of the assemblies are shown in exploded views which show the relationship of the parts and how they go together. Important assembly notes and special torque values are included in the illustrations. For standard hardware, a torque specification chart is included.

To order, enclose this form with a check or money order made out to SIMPLICITY. Address the envelope to:

Simplicity Manufacturing, Inc.
Attn: Cashier
500 N. Spring Street
P.O. Box 210
Port Washington, WI 53074

**Extend Equipment Life -
Use Only Genuine
Simplicity Repair Parts**

Simplicity

- I would like a parts manual (TP-1105) for my SunRunner Riding Mower. Enclosed is a check or money order for \$5.00.

Rider Mfg. No. _____

Rider Serial No. _____

Mower Mfg. No. _____

Mower Serial No. _____

Print clearly. This will be your mailing label.
Allow four to six weeks for delivery.

Name _____

Street or RFD _____

City, State, Zip _____

CUT HERE

Specifications

ENGINE

Make: Briggs & Stratton (See Engine Manual for specifications. See engine I.D. plate for model number.)

Fuel Capacity: Two gallons

GROUND SPEED

1st - 1.3 mph

2nd - 2.0 mph

3rd - 3.1 mph

4th - 3.8 mph

5th - 4.5 mph

Rev. - 1.5 mph

CONTROLS

Clutch: Combination clutch brake pedal, on right side.

Brake: 7" dia. type on drive axle.

Parking Brake: Lever type, located on brake pedal. Releases when pedal is pressed.

Gear Selector: Located on RH console, cable operated.

Mower Drive: Lever to left of seat.

Mower Height: 5 pin positions on mower deck.

Throttle Control: Combination engine speed and choke control located on LH console.

Starter: Key switch electric start.

Steering: Stainless steel control cable for each rear wheel

Turning Radius: 6"

DIMENSIONS

Height at Steering Wheel: 42"

Height at Top of Steering Column: 30 1/2"

Height at Top of Engine Cover: 24 1/4"

Height at Top of Seat: 34"

Length Overall: 82" w/42" Mower

Length Overall: 83 3/4" w/36" Mower

Length Overall of Rider: 64"

Width Overall: 57 1/2" w/42" Mower

Width Overall: 45 1/2" w 36" Mower

Width Over Front Tires: 36"

Width Over Rear Tires: 28"

Weight w/42" Mower: 490 lbs.

Weight w/36" Mower: 432 lbs.

Fuel Tank Capacity: 2 gallons

Rear Wheels: 4.1/3.5-4 Pneumatic, 10 psi

Front Wheels: 15 x 6-6.00 Pneumatic, 10 psi

Simplicity Manufacturing, Inc.
500 N. Spring Street
P.O. Box 997
Port Washington, WI 53074-0997

FORM - 1700997
PRINTED IN U.S.A.
882

Copyright © 1988 Simplicity Manufacturing, Inc.

Simplicity[®]